

NO.	Description	Part No.
1	End Cap	5T1C0138NT
2	Stop Valve	5Y0311700NT0
3	Pressure Balance Cartridge	5D0005800PL0
4	Cartridge Nut	5L0173800AL0
5	Stem & Threaded Nipple	9Q1173NT

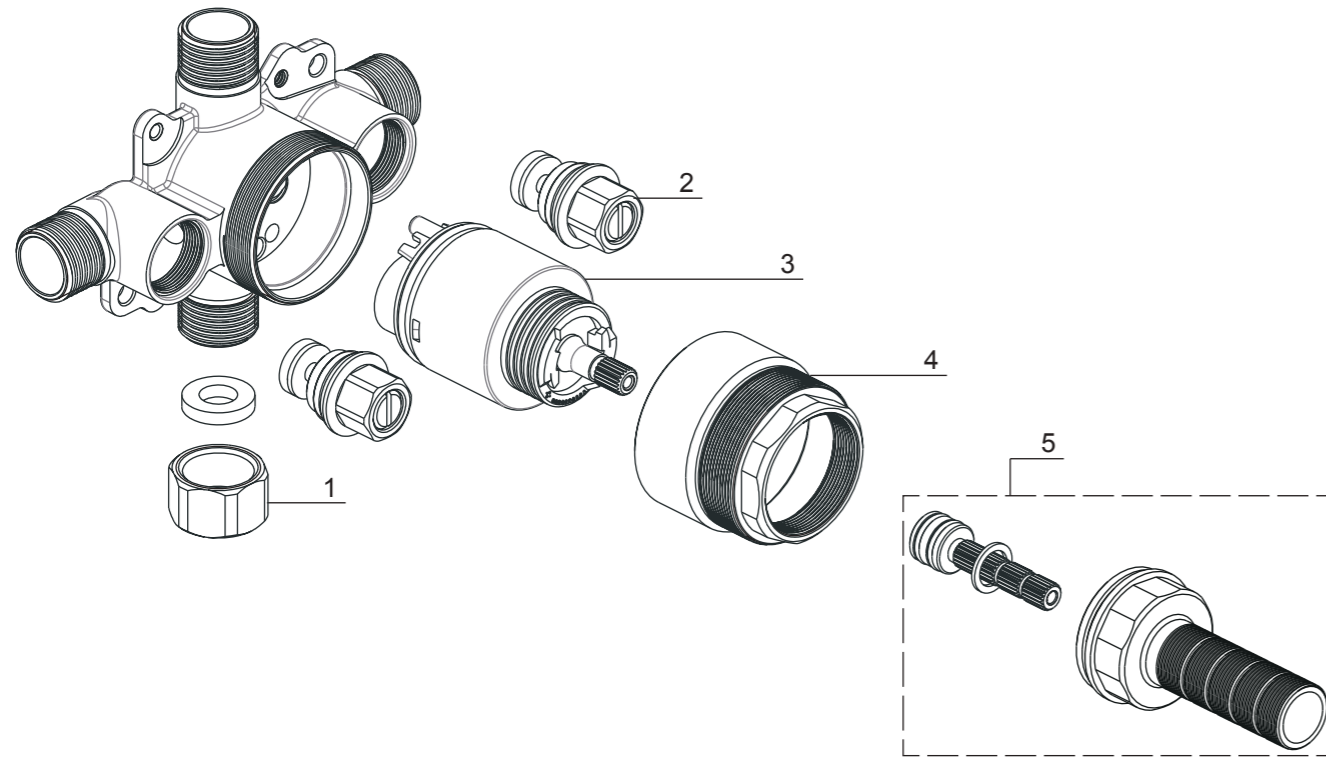

Limited Lifetime Warranty

Ultra Faucets warrants to the original purchaser that its products will be free from defects in workmanship and materials. All Ultra Faucets are provided with a life time limited warranty. This warranty does not cover any other labor or service charges associated with the removal, repair, or reinstallation of Ultra Faucets products. This express warranty does not apply to products that have been damaged as a result of misuse, abuse, negligence, accident, faulty installation or maintenance practices and/or used in any manner contrary to those recommended by the manufacturer.

Need help? Please call our toll-free customer service line at 1-888-658-5872 for additional assistance or service.

Besoin d'aide? Veuillez communiquer avec notre service à la clientèle au numéro gratuit 1-888-658-5872 pour tous renseignements ou services complémentaires.

¿Requiere asistencia? Llame a nuestro Servicio al Cliente, sin costo, al 1-888-658-5872 para asistencia adicional o servicio.

Installation/Installation/Instalación

CUSTOMER SERVICE

TOLL-FREE 1-888-OK-ULTRA (658-5872)



Tools You Will Need / Outils dont vous aurez besoin / Herramientas necesarias



Adjustable Wrench
Clé à molette
Llave ajustable



Pipe Tape
Ruban pour tuyau
Cinta selladora para rosca

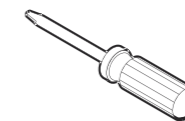

Screwdriver
Tournevis
Destornillador

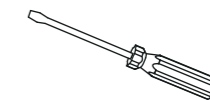

Phillips Screwdriver
Tournevis Phillips
Destornillador cruciforme

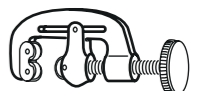

Tube Cutter
Machine Coupez le tuyau
Bañera de corte

SAFETY TIPS

- If you use soldering for the installation of the faucet, the seats, cartridges and washers will have to be removed before using flame. Otherwise, warranty will be void on those parts.
- Cover your drain to avoid losing parts.
- 0°C~55°C.

CONSIGNES DE SÉCURITÉ

- Si vous posez le robinet par brasage, il est essentiel de retirer les sièges, les cartouches et les rondelles avant d'appliquer la flamme, faute de quoi la garantie sur ces pièces sera annulée.
- Couvrez le drain pour ne pas perdre des pièces.
- 0°C~55°C.

CONSEJOS DE SEGURIDAD

- En el caso de utilizar soldadura para instalar el grifo, remueva los asientos, cartuchos y arandelas antes de usar la llama. De lo contrario, se anulará la garantía para esos componentes.
- Tape la boca del desagüe para prevenir la pérdida de piezas pequeñas.
- 0°C~55°C.

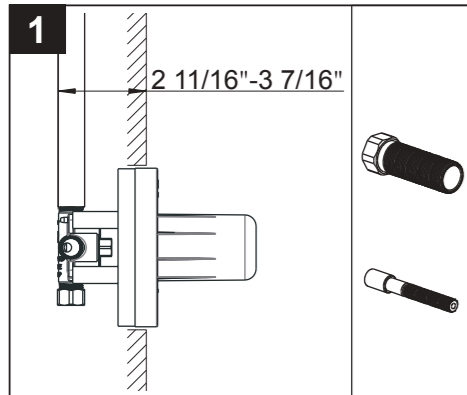

This valve is designed to fit into a wall that is 2 7/8" to 3 7/8" from finished wall to the back of the valve. Extensions are shipped with the trim if necessary.

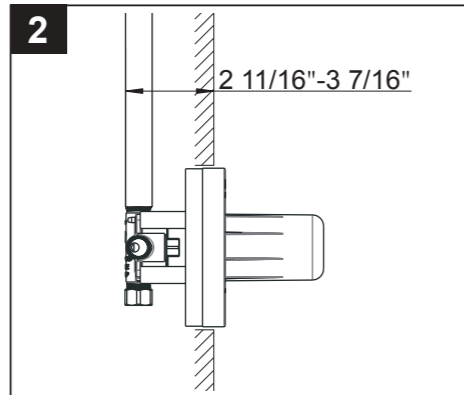

Turn off the water supplies. Install the valve so the finished wall will fit between the markers on the mud guard.

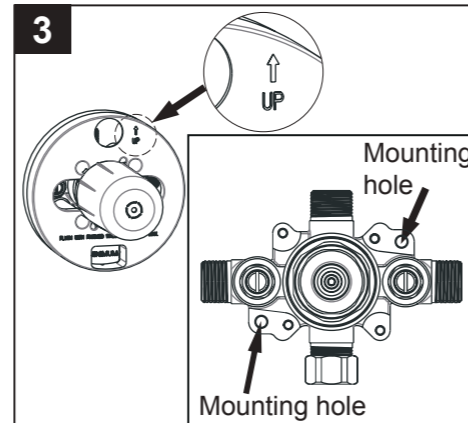

Using mounting holes secure the valve making sure the "UP" label outlet is on top.

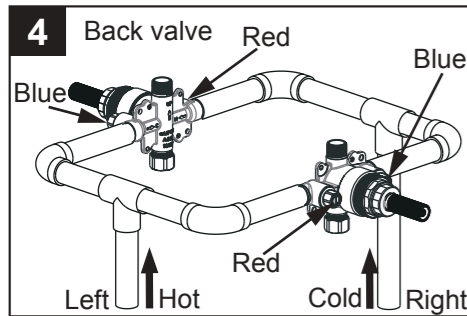

If you are making a back-to-back installation (hot on right and cold on the left), install the back valve body as described in steps #5 – #6. If not, go to step #7. NOTE: Notice that the back valve has hot and cold indicators that will be opposite of the incoming supply lines.

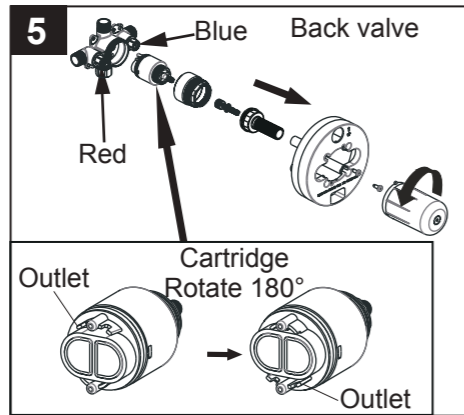

Remove the cartridge and stem assembly. Notice that the outlet is at the top. Rotate the cartridge 180°. The outlet should be on the bottom.

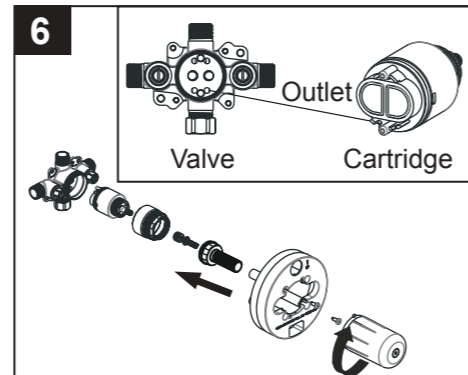

Align the outlet on the bottom of the cartridge and push the cartridge into the valve. Make sure the cartridge is firmly installed into the valve body. Reinstall stem assembly with mud guard.

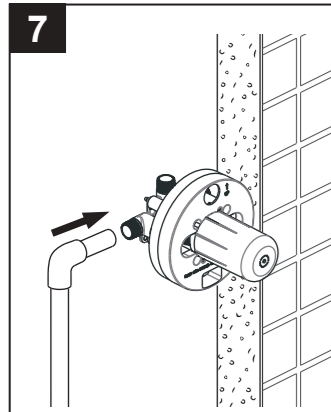

Warning

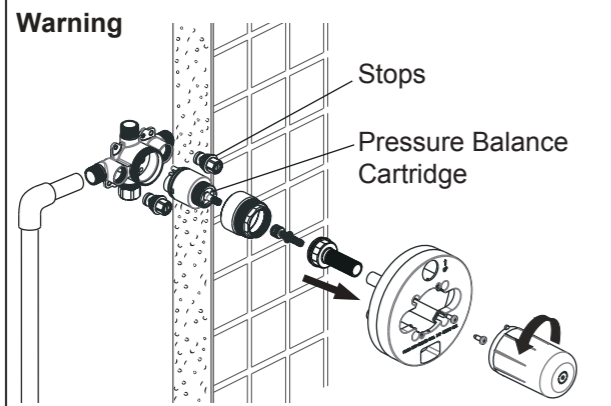

Connect valve body to water supplies using the proper fittings. Warning: avoid soldering at high temperature. Exposure to high temperature may damage the cartridge. Be sure stops and pressure balance cartridge are removed before soldering.

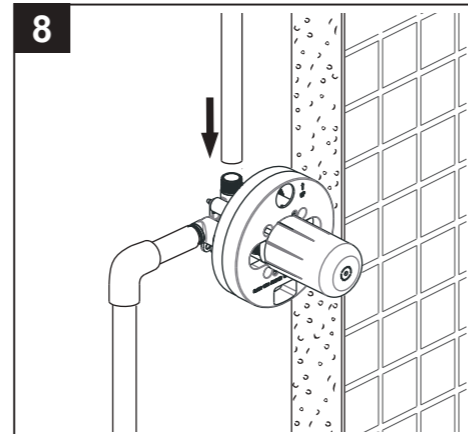

Connect the valve body to the shower outlet with the proper fitting. Note: it is suggested that you anchor all water lines.

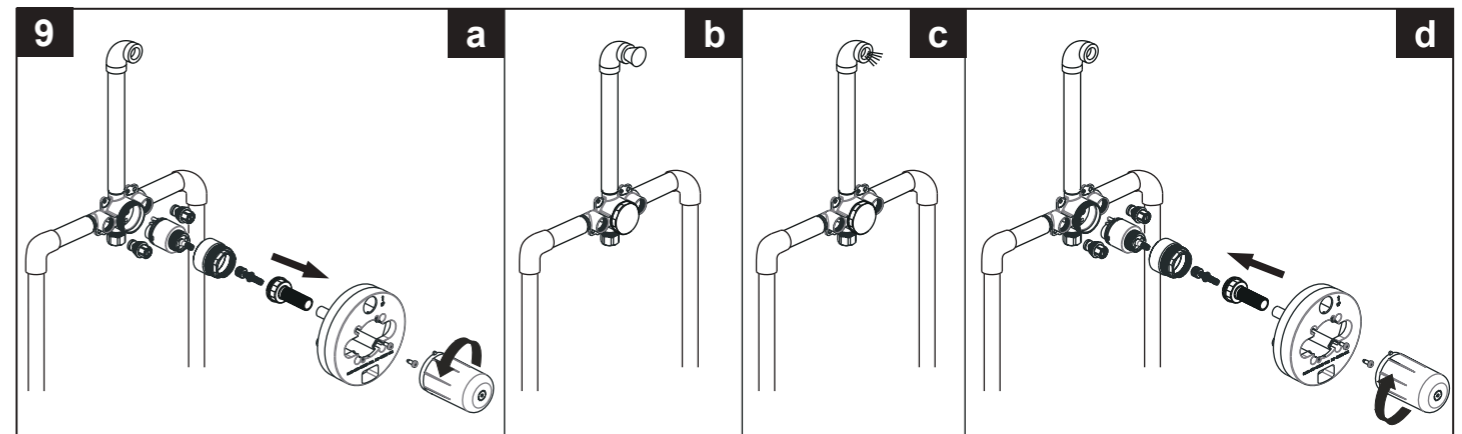

1. Pressure test and flush the valve.
 a. Prior to testing, remove mud guard, stem assembly, cartridge as stops as shown.
 b. Plug the shower outlet and check for leaks.
 c. After testing, flush system.
 d. Remove shower outlet plug. Re-install the stops, cartridge, stem assembly and mud guard.
 2. Check for leaks.

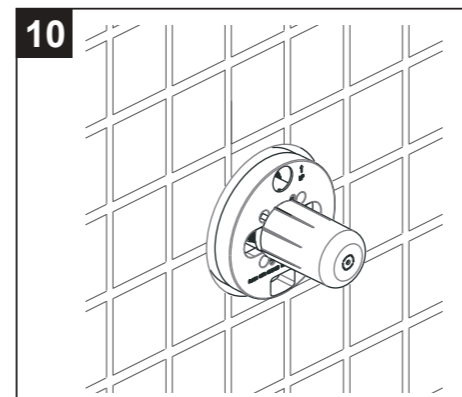

Installation completed.



CUSTOMER SERVICE

TOLL-FREE 1-888-OK-ULTRA (658-5872)

<http://www.ultrafaucets.com>

**UF79300
UF79303**



Installation/Installation/Instalación

Twist Series

Single Handle Tub and Shower Trim Kit



Tools You Will Need / Outils dont vous aurez besoin / Herramientas necesarias



Adjustable Wrench

Clé à molette

Llave ajustable



Pipe Tape

Ruban pour tuyau

Cinta selladora para rosca



Groove join pliers

Pince multiprise

Pinzas ajustables

SAFETY TIPS

- If you use soldering for the installation of the faucet, the seats, cartridges and washers will have to be removed before using flame. Otherwise, warranty will be void on those parts.
- Cover your drain to avoid losing parts.
- 0°C~55°C

CONSIGNES DE SÉCURITÉ

- Si vous posez le robinet par brasage, il est essentiel de retirer les sièges, les cartouches et les rondelles avant d'appliquer la flamme, faute de quoi la garantie sur ces pièces sera annulée.
- Couvrez le drain pour ne pas perdre des pièces.
- 0°C~55°C

CONSEJOS DE SEGURIDAD

- En el caso de utilizar soldadura para instalar el grifo, remueva los asientos, cartuchos y arandelas antes de usar la llama. De lo contrario, se anulará la garantía para esos componentes.
- Tape la boca del desagüe para prevenir la pérdida de piezas pequeñas.
- 0°C~55°C

Installation/Installation/Instalación

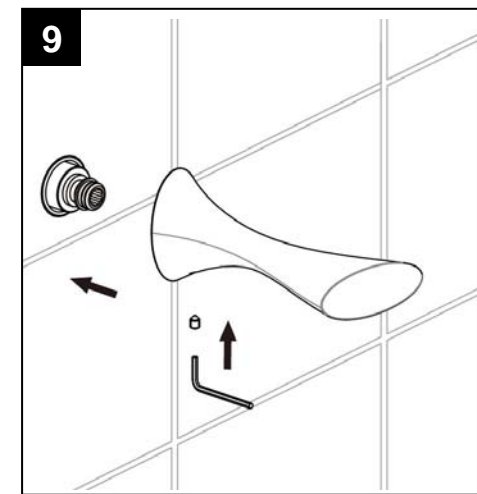
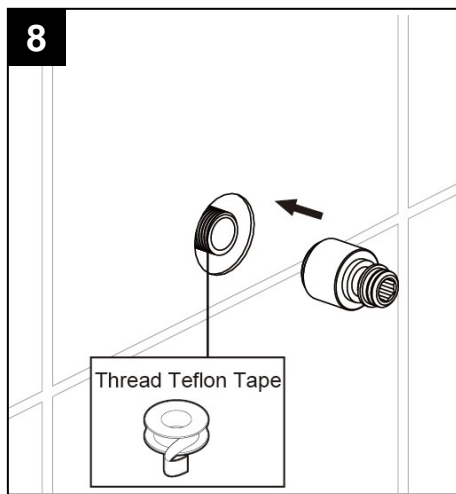
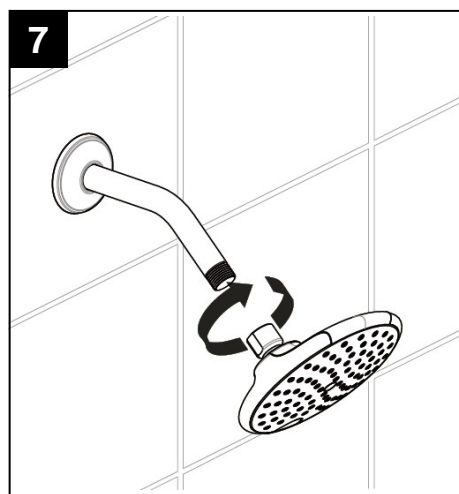
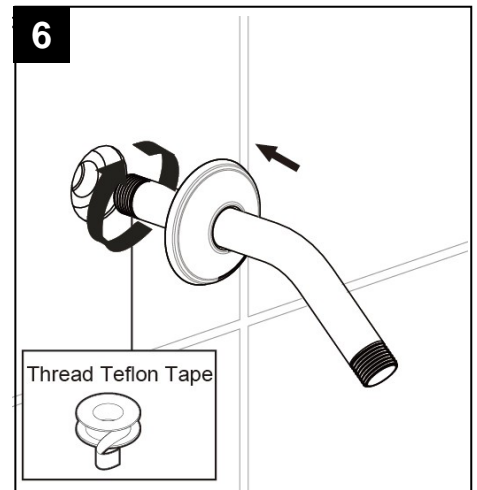
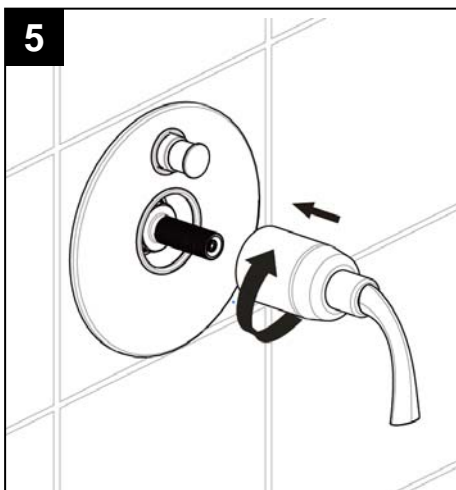
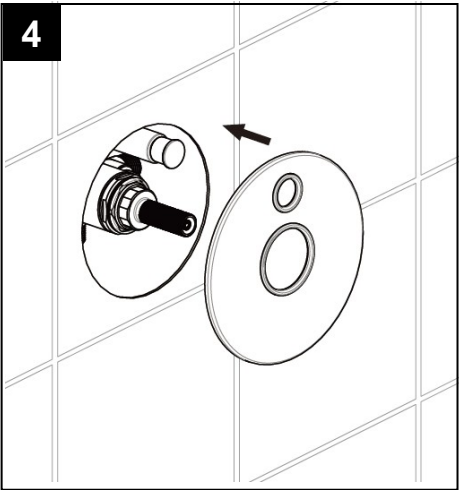
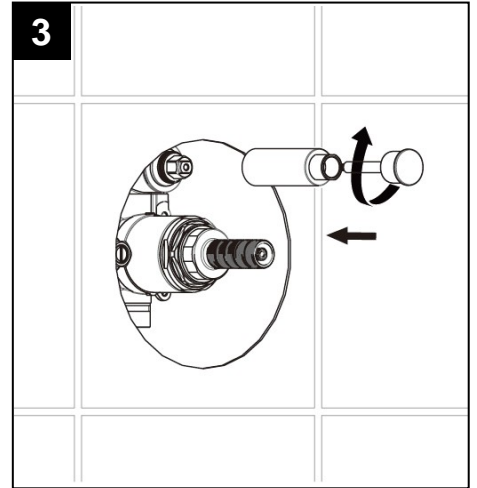
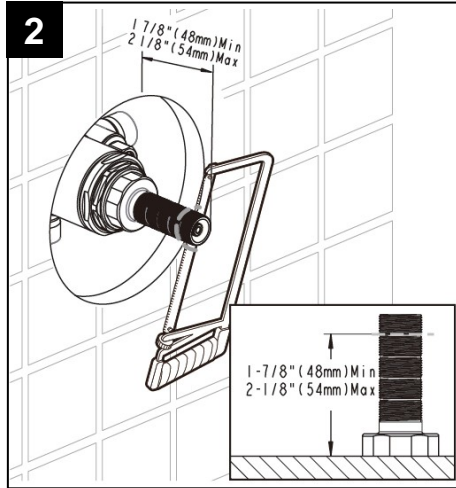
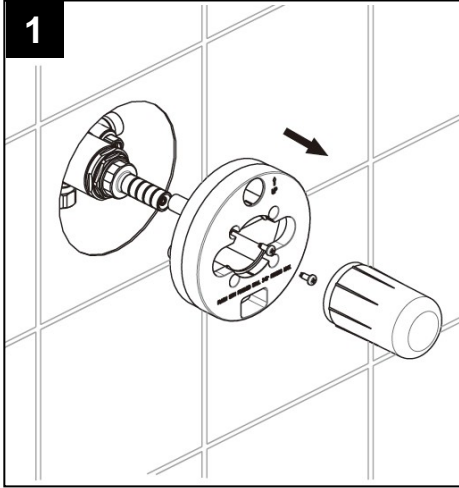

Installation/Installation/Instalación

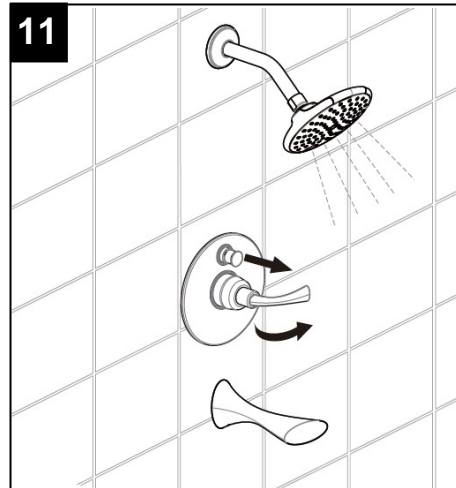
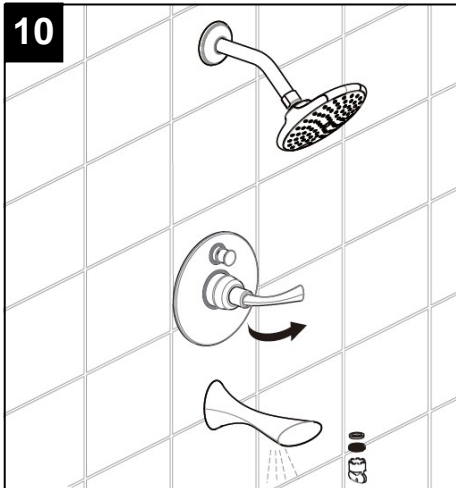

Trouble-Shooting / Dépannage / Guía de solucionar

If you've followed the instructions carefully and your faucet still does not work properly, take these corrective steps.

Si vous avez suivi attentivement les instructions et que votre robinet ne fonctionne toujours pas correctement, apporter les correctifs suivants.

Si usted ha seguido las instrucciones cuidadosamente y su grifo todavía no funciona correctamente, siga estos pasos correctivos.

Problem/Problème/Problema	Cause/Cause/Causa	Action/Correctif/Solución
Aerator leaks or has an inconsistent water flow pattern.	The stop valve connected to the Hot/Cold water supply is not opened.	Unscrew aerator, remove any debris, check seating of seal then re-assembly aerator.
Leaks underneath Shower Head.	Retainer Shower Head has come loose.O-ring is dirty or damaged.	Tighten the retainer nut. Clean or replace O-ring.

Replacement Parts / Pièces de rechange / Repuestos

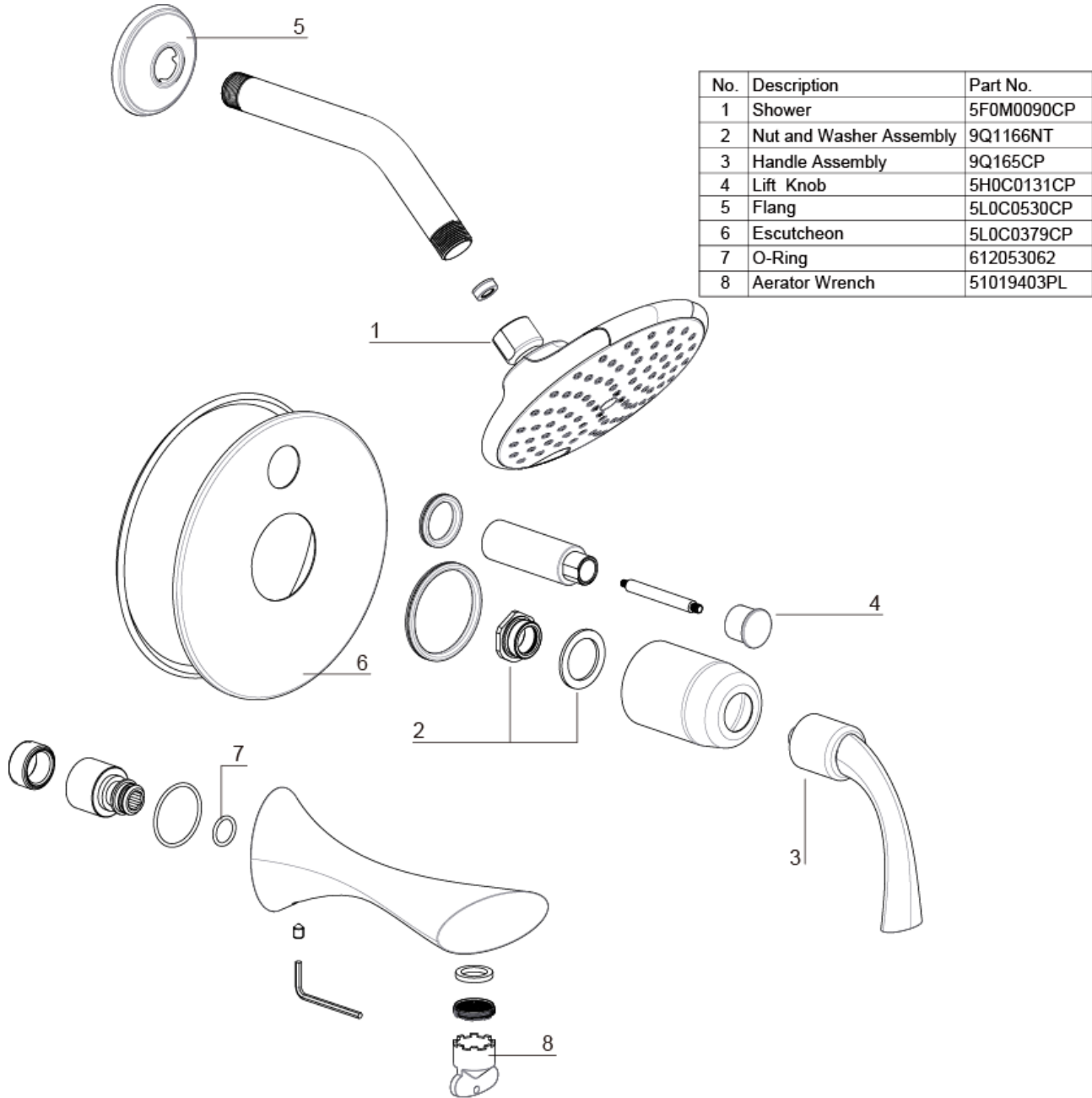

Limited Lifetime Warranty

Ultra Faucets warrants to the original purchaser that its products will be free from defects in workmanship and materials. All Ultra Faucets are provided with a life time limited warranty. This warranty does not cover any other labor or service charges associated with the removal, repair, or reinstallation of Ultra Faucets products. This express warranty does not apply to products that have been damaged as a result of misuse, abuse, negligence, accident, faulty installation or maintenance practices and/or used in any manner contrary to those recommended by the manufacturer.

Need help? Please call our toll-free customer service line at 1-888-658-5872 for additional assistance or service.

Besoin d'aide? Veuillez communiquer avec notre service à la clientèle au numéro gratuit 1-888-658-5872 pour tous renseignements ou services complémentaires.

¿Requiere asistencia? Llame a nuestro Servicio al Cliente, sin costo, al 1-888-658-5872 para asistencia adicional o servicio.