

Installation/Installation/Instalación

CUSTOMER SERVICE

TOLL-FREE 1-888-OK-ULTRA (658-5872)



No.	Description	Part No.
1	Aerator Assembly	5Y0004800CP7
2	Push Drain Assembly	5Y0M0172
3	Hose M8X1 (Hot)	5G0M0019CC7
4	Hose M8X1 (Cold)	5G0M0022CC7
5	Lavatory Spout Mounting Hardware	9Q1051NT
6	O-Ring D37.5XD2.5	611240112
7	Plug	5L0P0036
8	Set Screw	5T0F0149NT
9	Dome	5L0P0120
10	Screw M4	5T0F0194NT
11	Nut	5T1C0190NT
12	Cartridge	5D0M0022PL

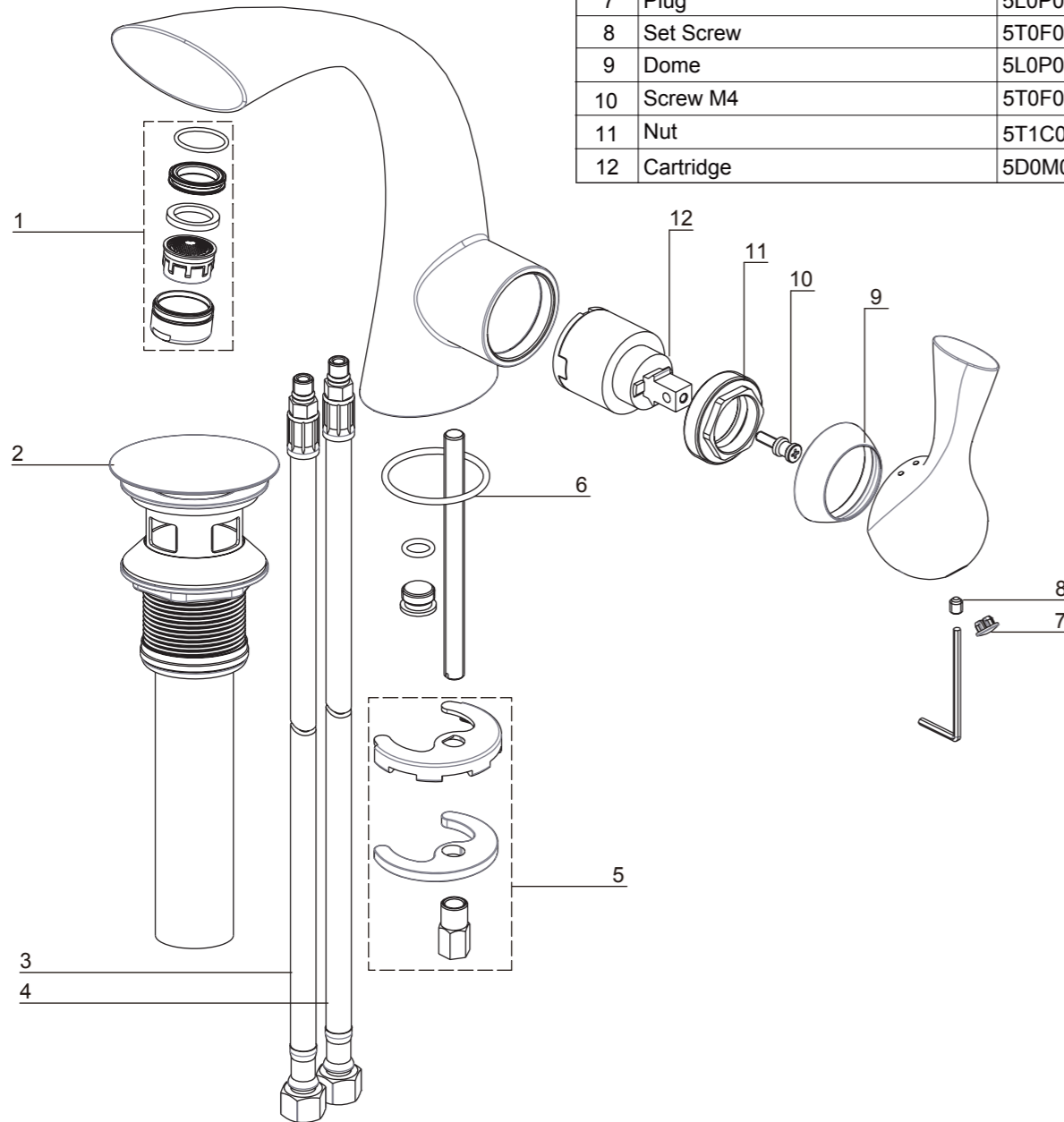

Tools You Will Need / Outils dont vous aurez besoin / Herramientas necesarias



Adjustable Wrench
Clé à molette
Llave ajustable



Pipe Tape
Ruban pour tuyau
Cinta selladora para rosca

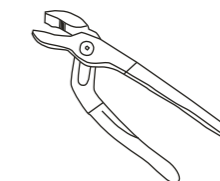

Groove join pliers
Pince multiprise
Pinzas ajustables

Limited Lifetime Warranty

Ultra Faucets warrants to the original purchaser that its products will be free from defects in workmanship and materials. All Ultra Faucets are provided with a life time limited warranty. This warranty does not cover any other labor or service charges associated with the removal, repair, or reinstallation of Ultra Faucets products. This express warranty does not apply to products that have been damaged as a result of misuse, abuse, negligence, accident, faulty installation or maintenance practices and/or used in any manner contrary to those recommended by the manufacturer.

Need help? Please call our toll-free customer service line at 1-888-658-5872 for additional assistance or service.

Besoin d'aide? Veuillez communiquer avec notre service à la clientèle au numéro gratuit 1-888-658-5872 pour tous renseignements ou services complémentaires.

¿Requiere asistencia? Llame a nuestro Servicio al Cliente, sin costo, al 1-888-658-5872 para asistencia adicional o servicio.

SAFETY TIPS

- If you use soldering for the installation of the faucet, the seats, cartridges and washers will have to be removed before using flame. Otherwise, warranty will be void on those parts.
- Cover your drain to avoid losing parts.
- 0°C~55°C

CONSIGNES DE SÉCURITÉ

- Si vous posez le robinet par brasage, il est essentiel de retirer les sièges, les cartouches et les rondelles avant d'appliquer la flamme, faute de quoi la garantie sur ces pièces sera annulée.
- Couvrez le drain pour ne pas perdre des pièces.
- 0°C~55°C

CONSEJOS DE SEGURIDAD

- En el caso de utilizar soldadura para instalar el grifo, remueva los asientos, cartuchos y arandelas antes de usar la llama. De lo contrario, se anulará la garantía para esos componentes.
- Tape la boca del desagüe para prevenir la pérdida de piezas pequeñas.
- 0°C~55°C

Installation/Installation/Instalación

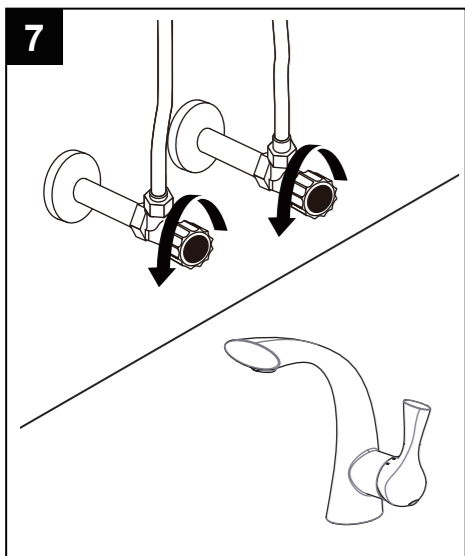
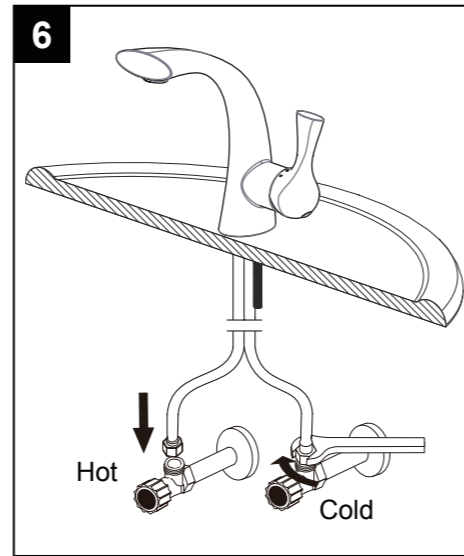
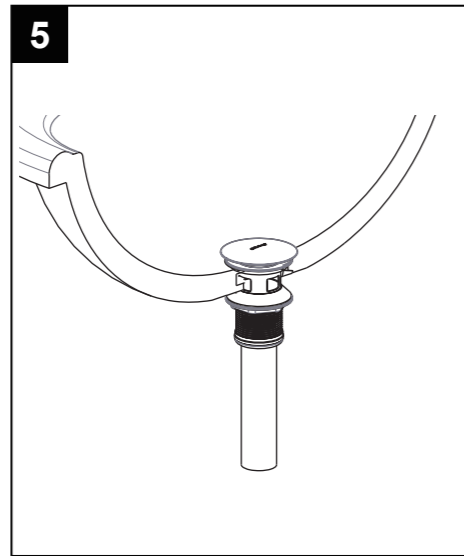
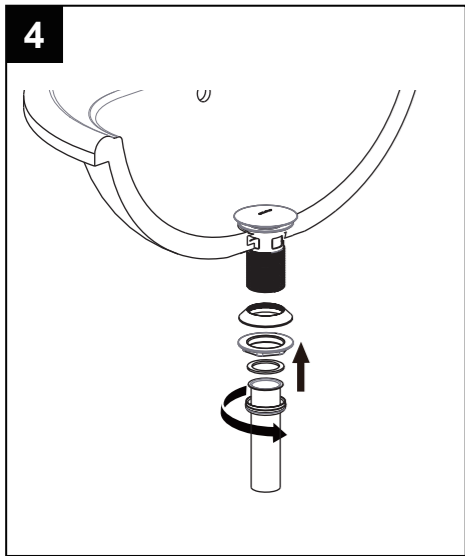
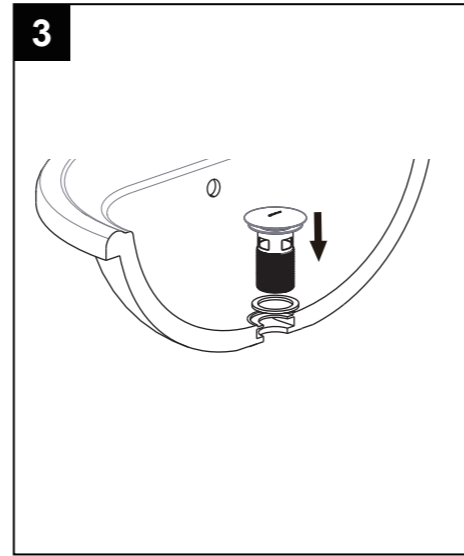
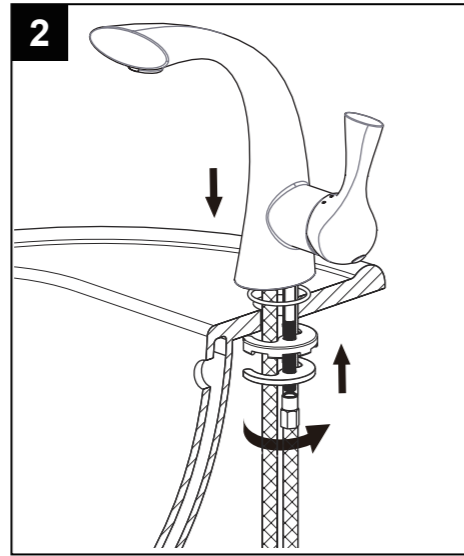
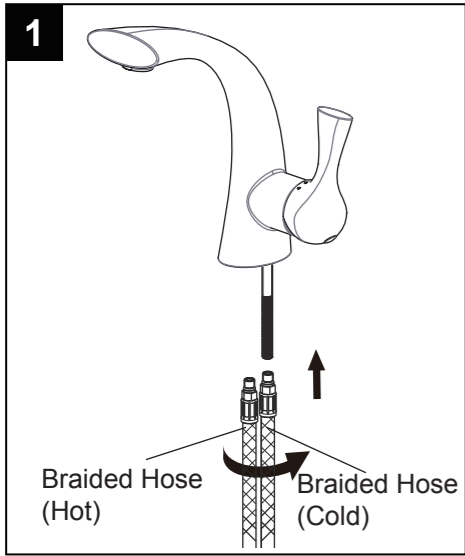
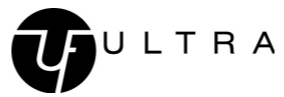

Trouble-Shooting / Dépannage / Guía de solucionar

If you've followed the instructions carefully and your faucet still does not work properly, take these corrective steps.

Si vous avez suivi attentivement les instructions et que votre robinet ne fonctionne toujours pas correctement, apporter les correctifs suivants.

Si usted ha seguido las instrucciones cuidadosamente y su grifo todavía no funciona correctamente, siga estos pasos correctivos.

Problem/Problème/Problema	Cause/Cause/Causa	Action/Correctif/Solución
Aerator leaks or has an inconsistent water flow pattern.	Aerator is dirty or misfitted.	Unscrew aerator, remove any debris, check seating of rubber seal then re-assembly aerator.
Leaks under the deck.	inspect supply line, tee and flex line connections.	tighten connections where necessary.