

# About the Wood and Finish

This product has been carefully crafted of: MDF, solid pine wood and/or pine veneers. These materials derive from plantations, a renewable and well managed forest, therefore, not endangering the environment. The highest quality standards have been implemented to assure a sturdy and reliable product. Due to the natural variances in the

graining of wood, you may notice subtle differences in the shading and tone of the color stain, warp, holes, wood knots and also small cracks. This is not a defect.

But rather a result of the natural beauty of the wood itself.

## Care and maintenance:

Dust when needed using a smooth, dry cloth. Household furniture polish can be used occasionally to restore luster.







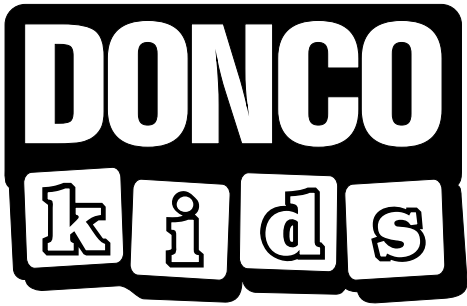

Fort Worth, Texas 76140

**ASSEMBLY INSTRUCTIONS**

1733F - Bookcase Day Bed Full

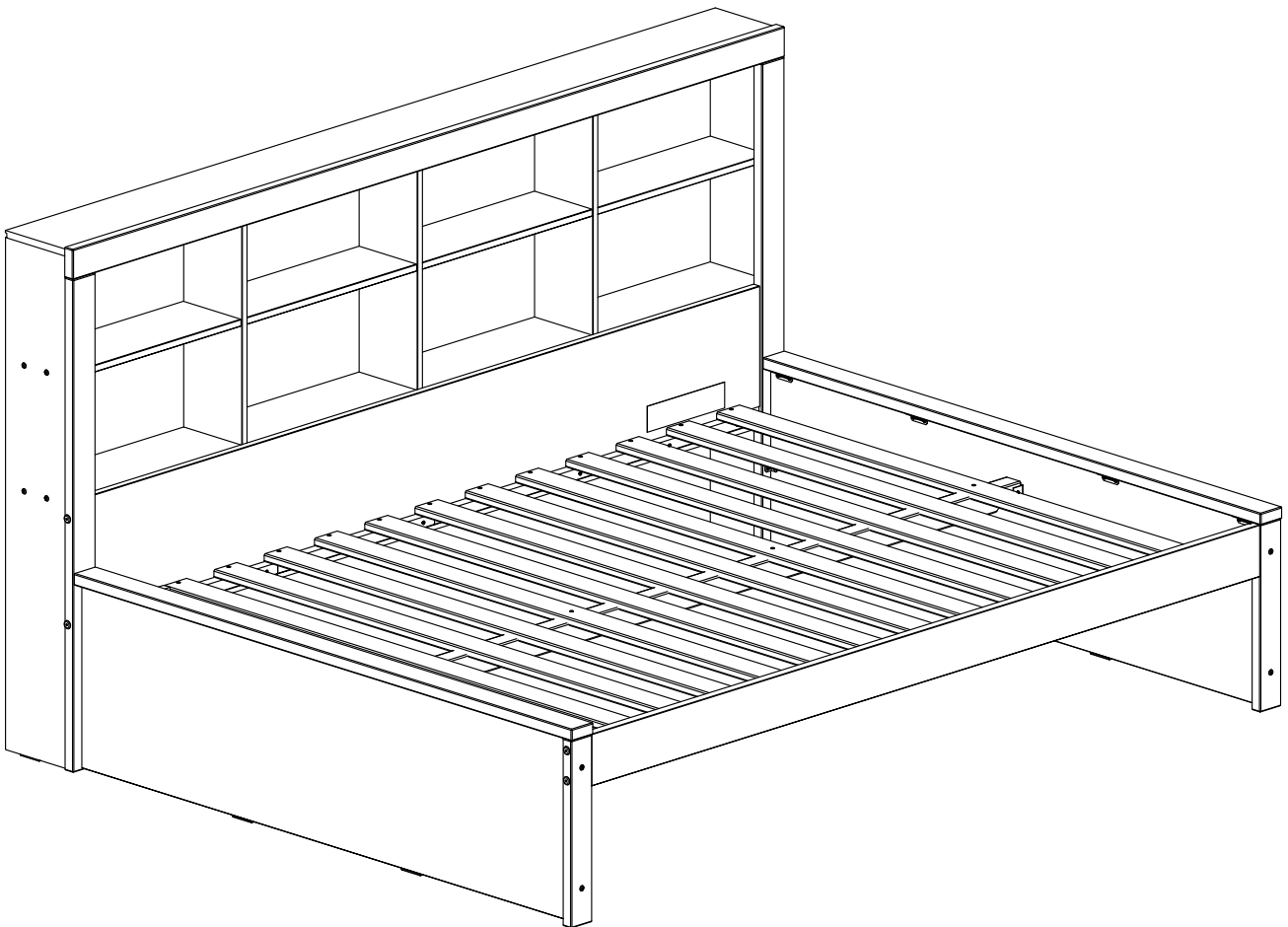

Thank you for purchasing this quality product. Be sure to check all packing material carefully for small parts which may have come loose inside the carton during shipment. Separate identify and count all parts and hardware.

Compare with the parts list to be sure all parts are present.

**"DO NOT TIGHTEN SCREWS UNTIL COMPLETELY ASSEMBLED"**

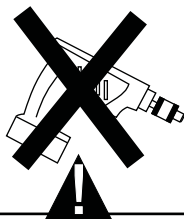

\* Use of power tool to assemble this product will invalidate any claim and damage this product making unsafe !!!  
\* Please assemble on a clean soft surface to avoid damage.

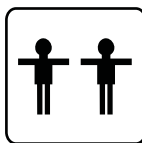

+

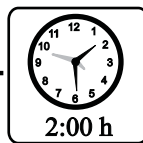

Tools Required

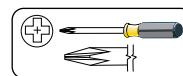

(Not included)

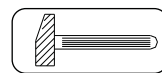

(Not included)

**IMPORTANT:**

**PLEASE READ INSTRUCTION BEFORE STARTING THE ASSEMBLY**

Part list: 1733F - Bookcase Day Bed Full

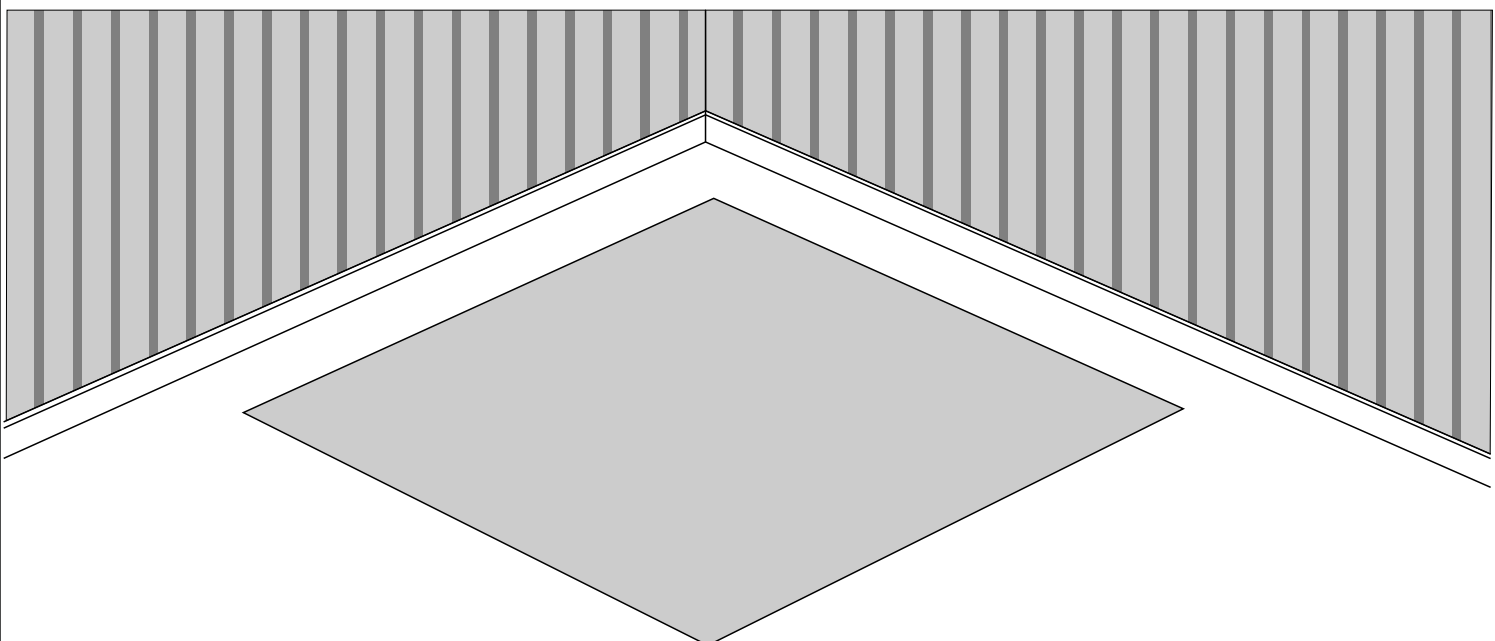
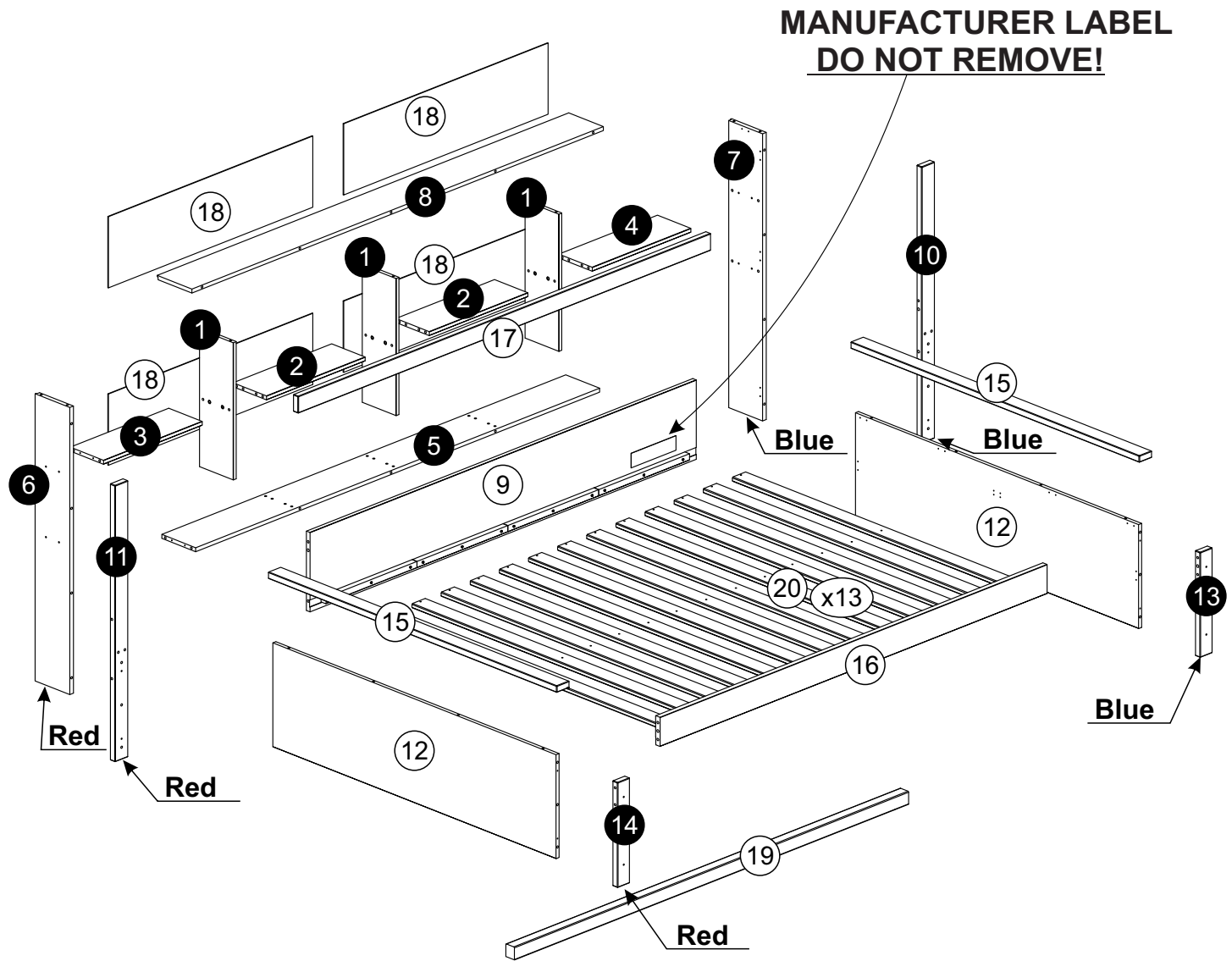

PLEASE USE A FLOOR PROTECT AS A RUG OR  
A CARDBOARD TO ASSEMBLY THE BOOKCASE !!!

# Identifying the Hardware-Identify the hardware using the illustrations below.

**A**  Qty **06**  
1 3/16" Wooden Dowel (10 x 40mm)

**B**  Qty **64**  
1 3/16" Wooden Dowel (8 x 30mm)

**C**  Qty **06**  
2" Wooden Dowel (8 x 50mm)

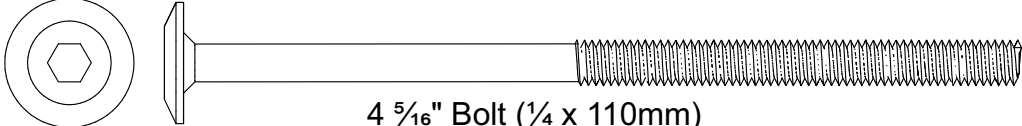
**D**  Qty **08**  
4 5/16" Bolt (1/4 x 110mm)

**E**  1/4" Half Moon Qty **08**

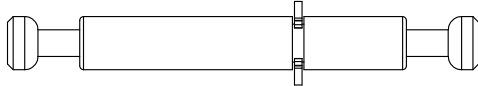
**F**  Qty **06**  
Cam Bolts

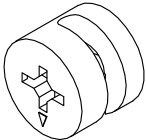
**G**  Cam Lock Qty **12**

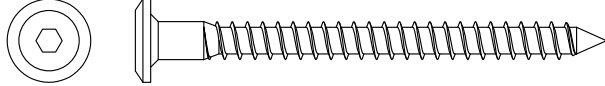
**H**  Qty **22**  
2 3/8" Bolt (5 x 60mm)

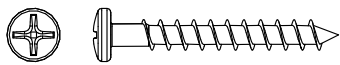
**I**  Qty **30**  
1 3/16" Screw (4 x 30mm)

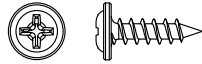
**J**  Qty **136**  
15/32" Screw (3.5 x 12mm)

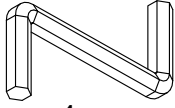
**K**  Large Allen wrench Qty **01**  
4mm

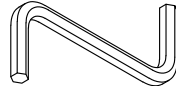
**L**  Small Allen wrench Qty **01**  
3mm

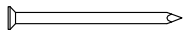
**M**  Qty **35**  
Nail (Anelado)

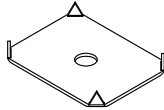
**N**  Metal Plate Qty **11**

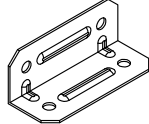
**O**  L-Bracket Qty **31**  
46x18mm

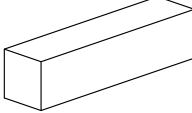
**P**  Wooden spacer Qty **02**  
2 15/16" (75 mm)

**Q**  Qty **06**  
Slider Legs

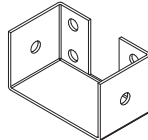
**R**  Qty **02**

\*Actual size of screws and bolts, for measurements checking.

**01**  PLEASE BE ATTENTIVE BECAUSE THE BOOKCASE SHELVES ARE IN 3 ASSEMBLY STEPS !!!

SEE THE PART # ON THE END OF PIECES

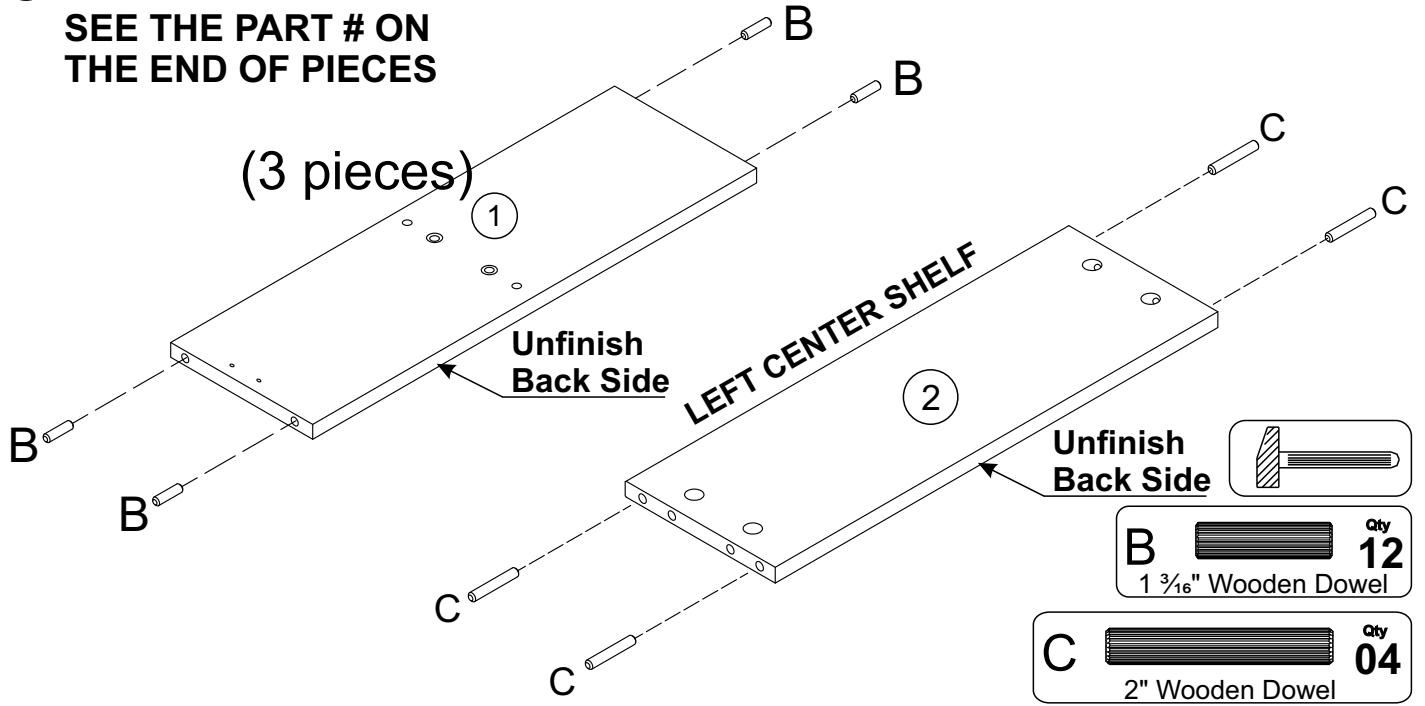

**02** **FIRST SET ASSEMBLED**

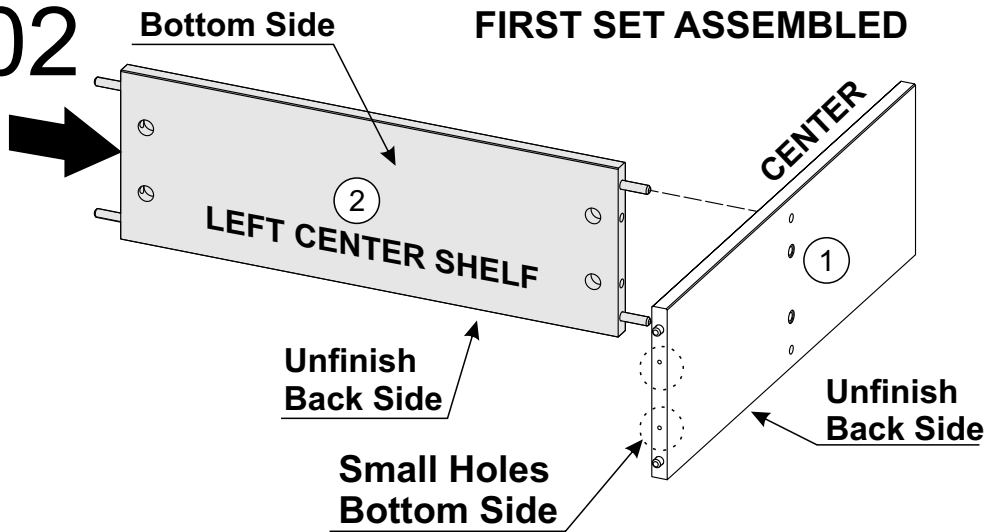

**START THE ASSEMBLY ON THE FLOOR TILL STEP #28**

**03**

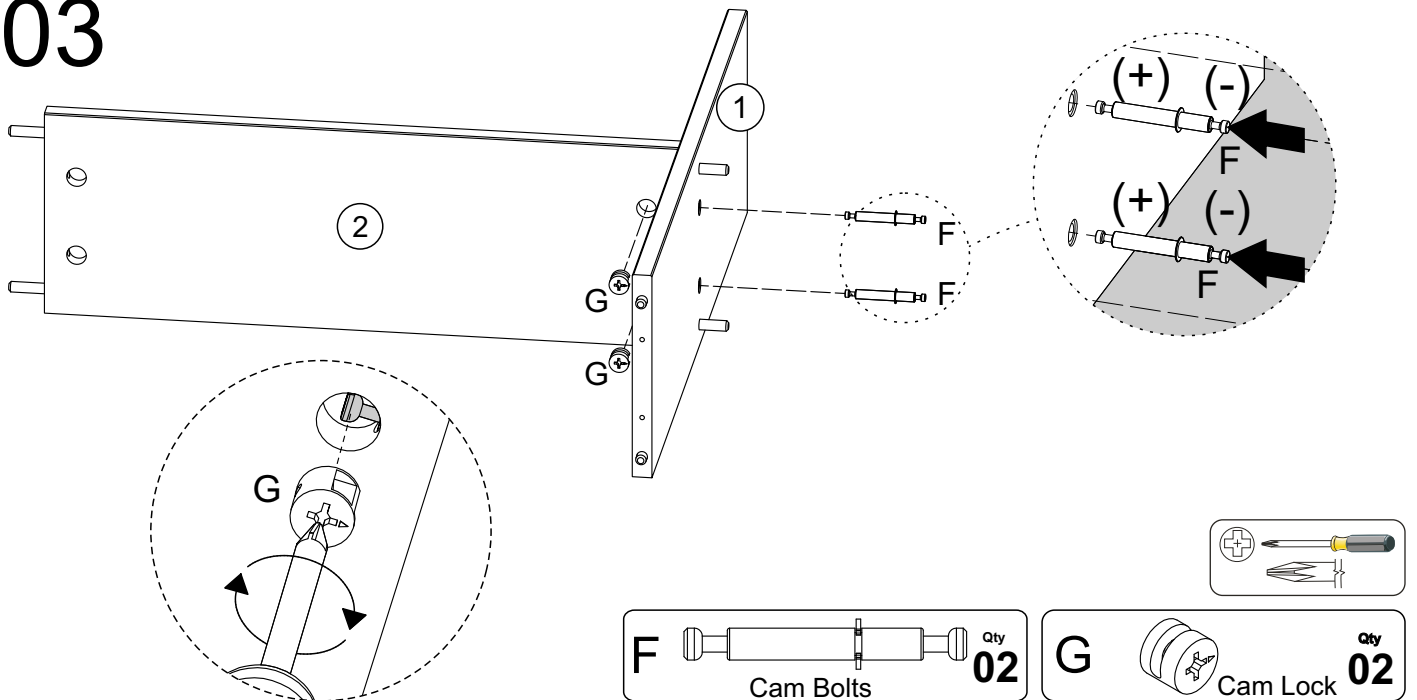

# 04



**ATTENTIVE TO KEEP THE FACE HOLES UPSIDE, EXACTLY AS THE DRAWING BELLOW.**

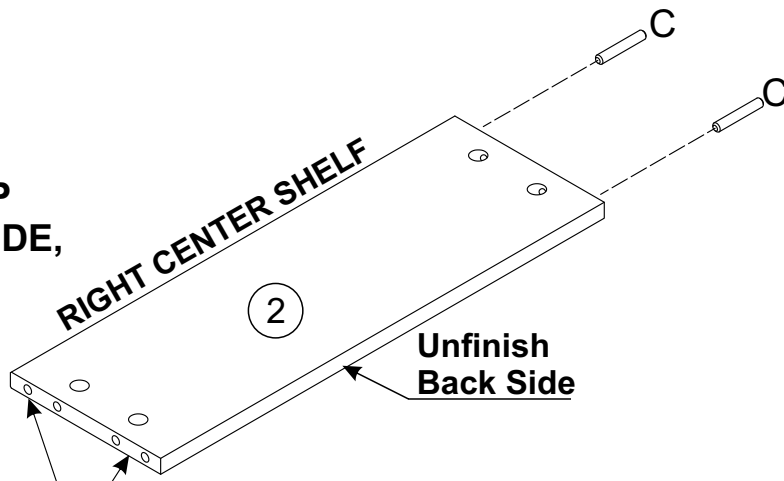

**NOT ADD WOODEN DOWEL IN THIS SIDE**

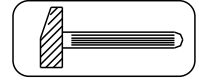

**C**  Qty **02**  
2" Wooden Dowel

# 05

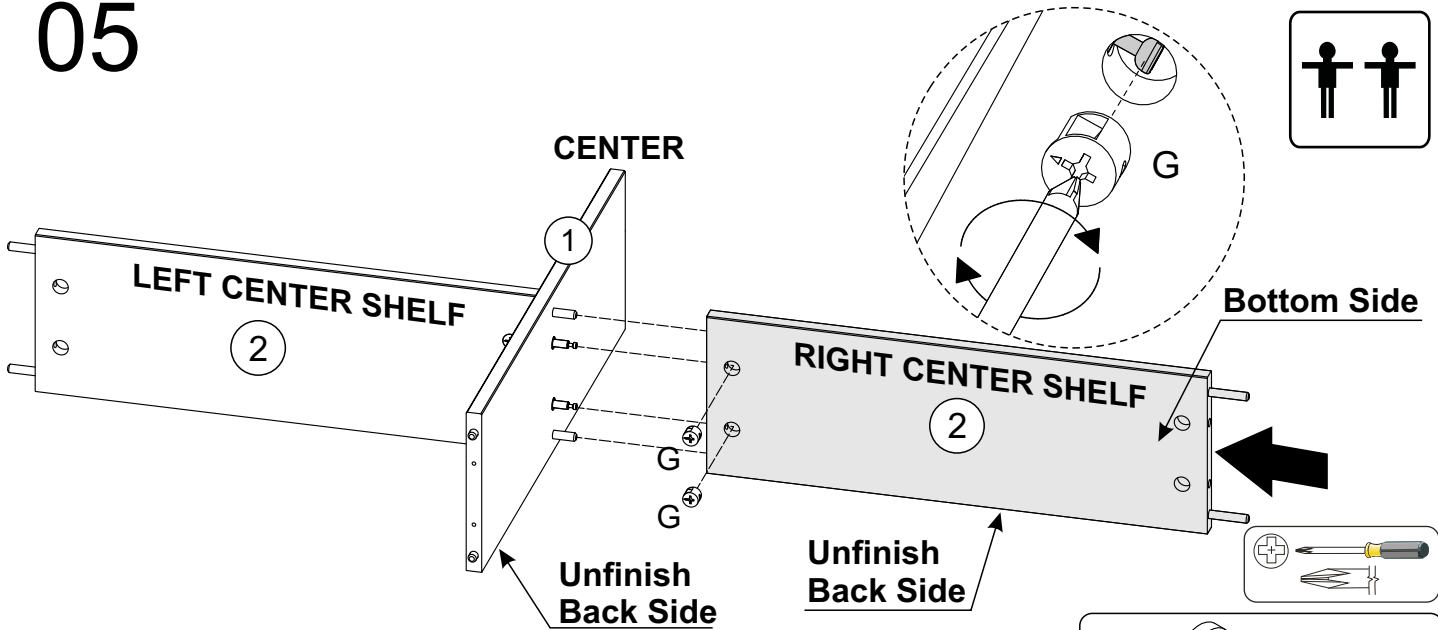

**G**  Qty **02**  
Cam Lock

# 06

## SECOND SET ASSEMBLED

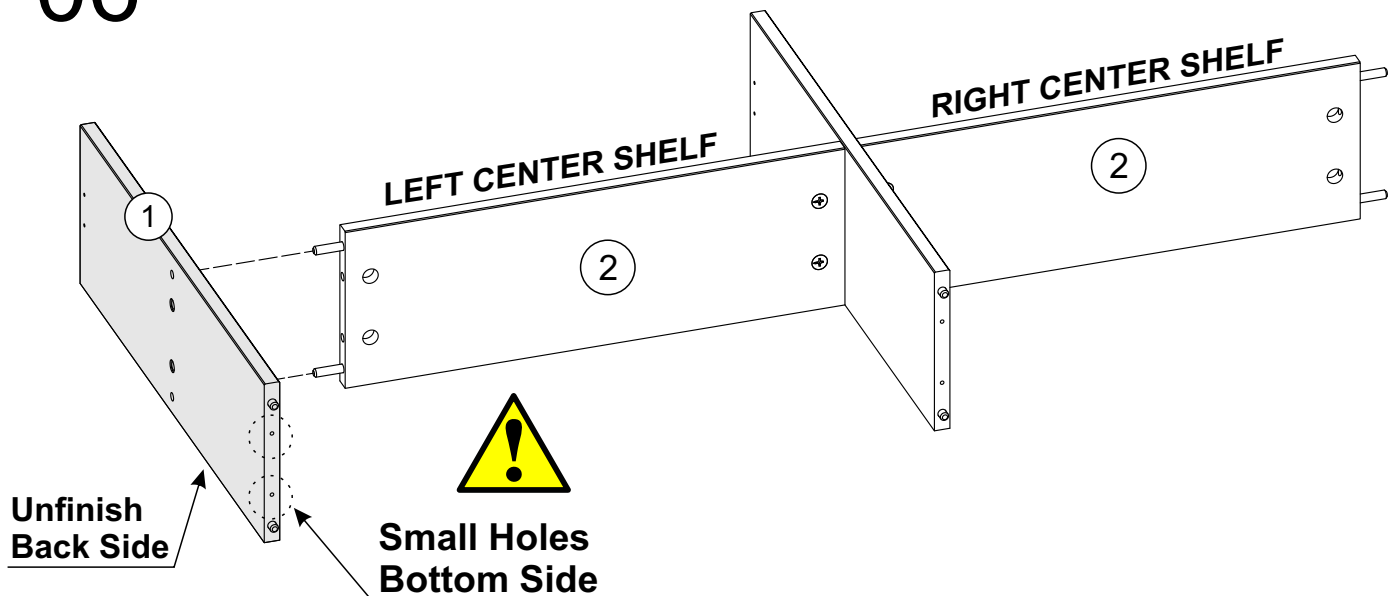

# 07



LEFT CENTER SHELF

RIGHT CENTER SHELF

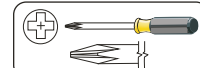
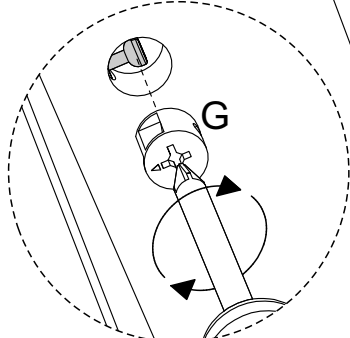
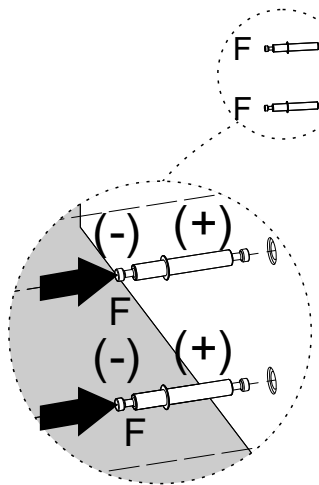

**G** Cam Lock Qty **02**

**F** Cam Bolts Qty **02**

# 08

**NOT ADD WOODEN DOWEL IN THIS SIDE**



**ATTENTIVE TO KEEP THE FACE HOLES UPSIDE, EXACTLY AS THE DRAWING BELOW.**

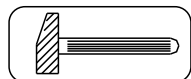
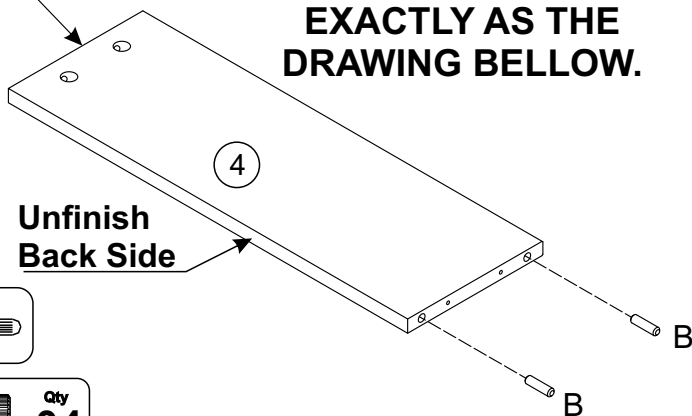
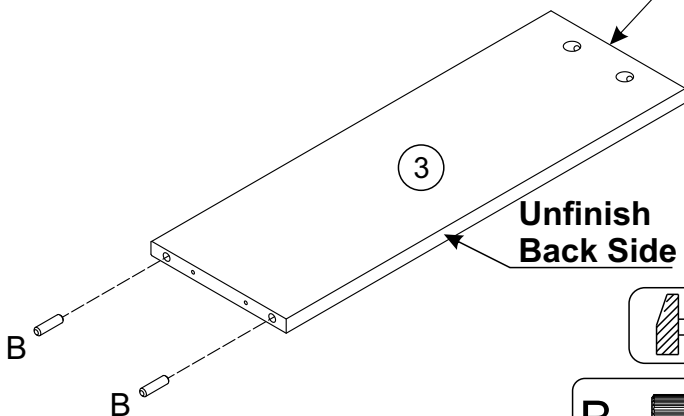

**B** Qty **04**  
1 3/16" Wooden Dowel

# 09

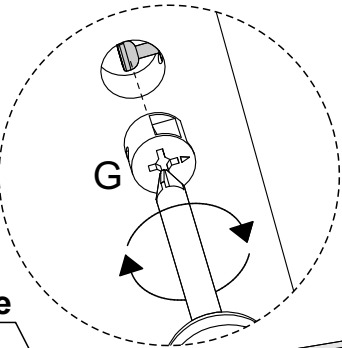
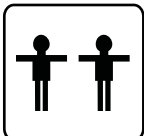

Bottom Side

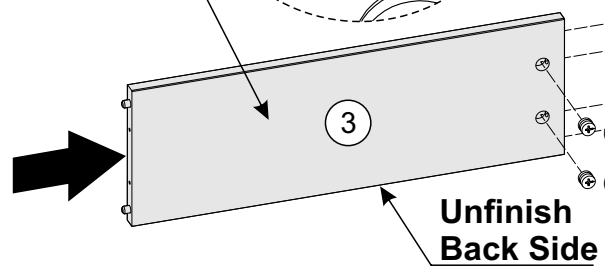

LEFT CENTER SHELF

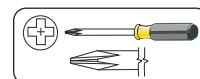

**G** Cam Lock Qty **02**



THIRD SET ASSEMBLED

10

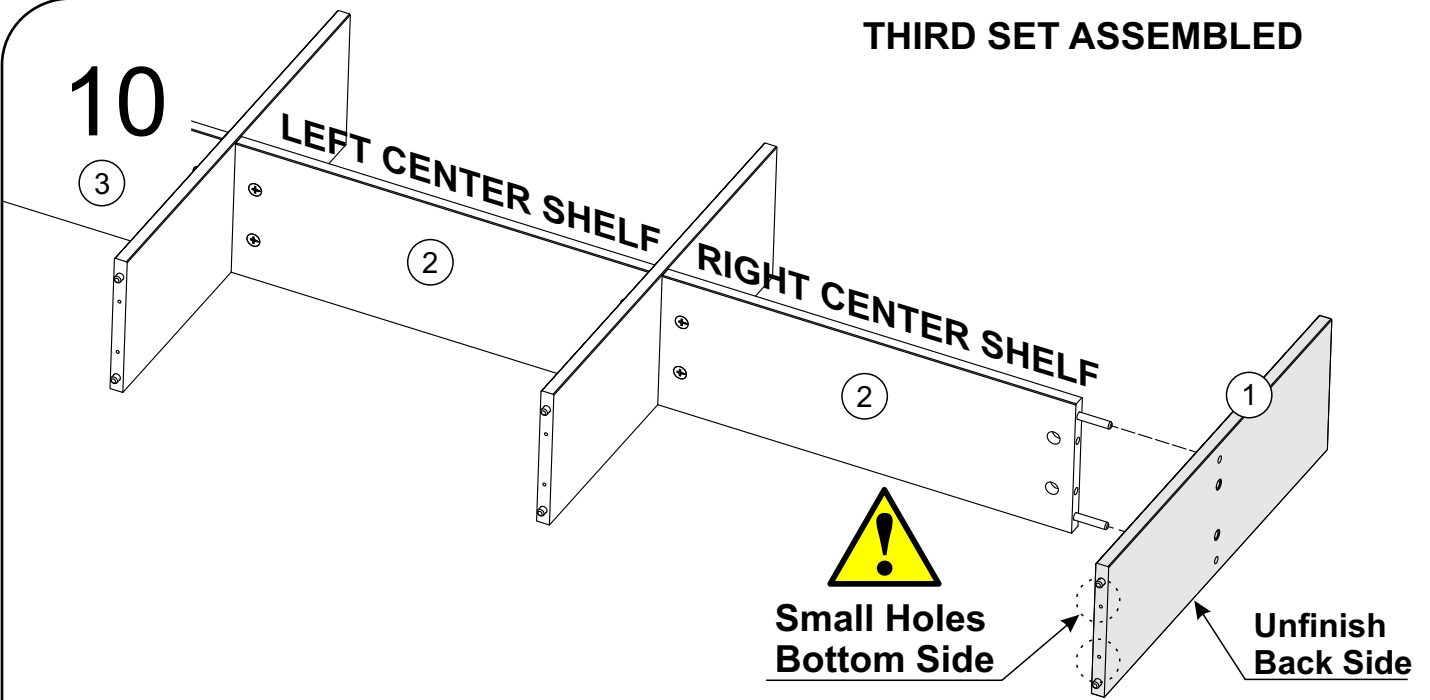

11

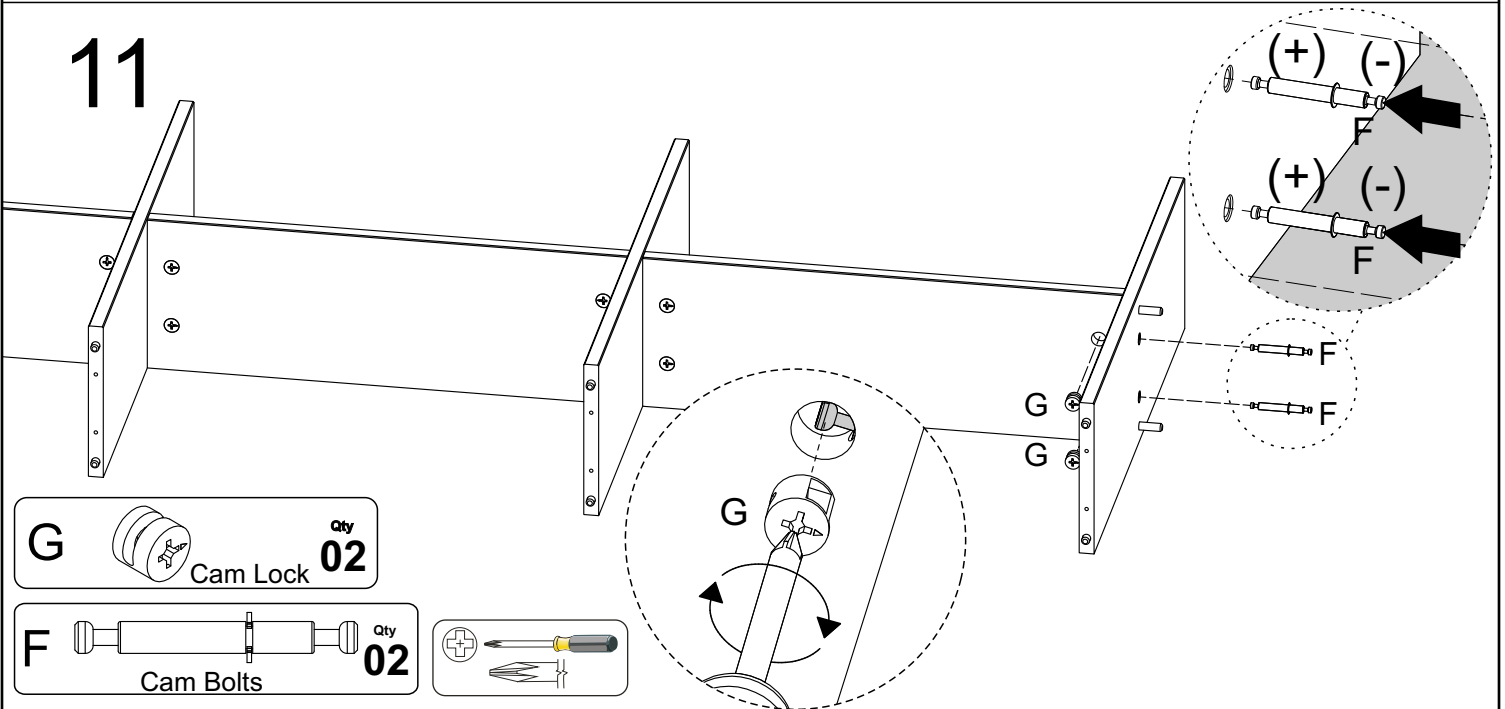

12

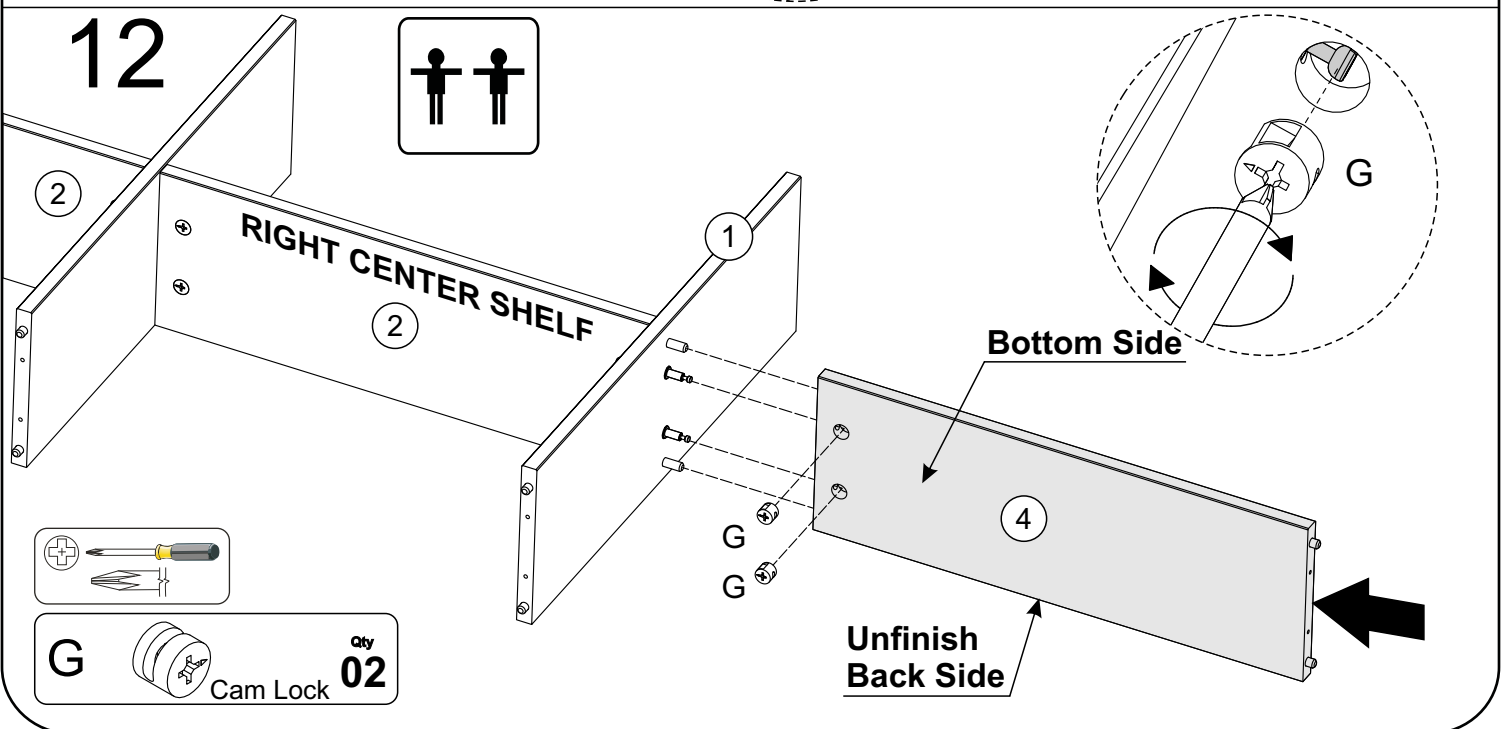

# 13

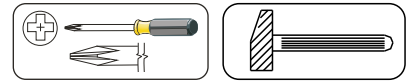
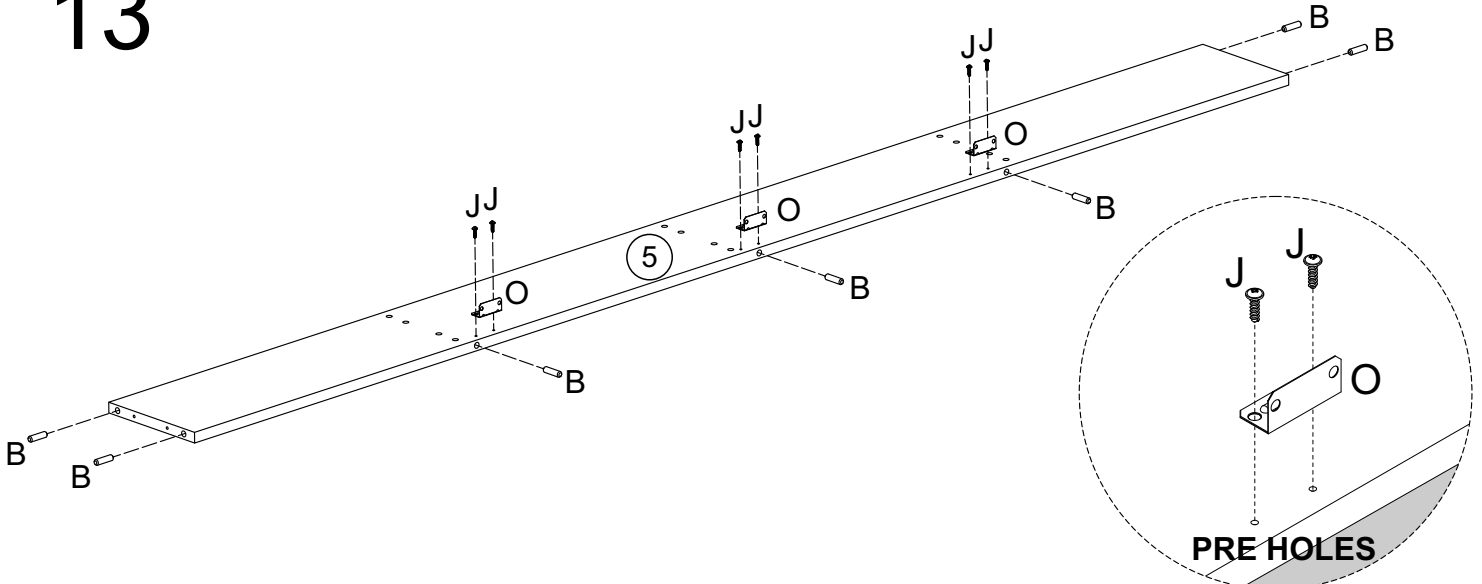

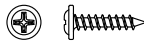

**B**  Qty **07**  
1 3/16" Wooden Dowel

**J**  Qty **06**  
15/32" Screw

**O**  Qty **03**  
L-Bracket

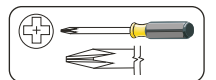
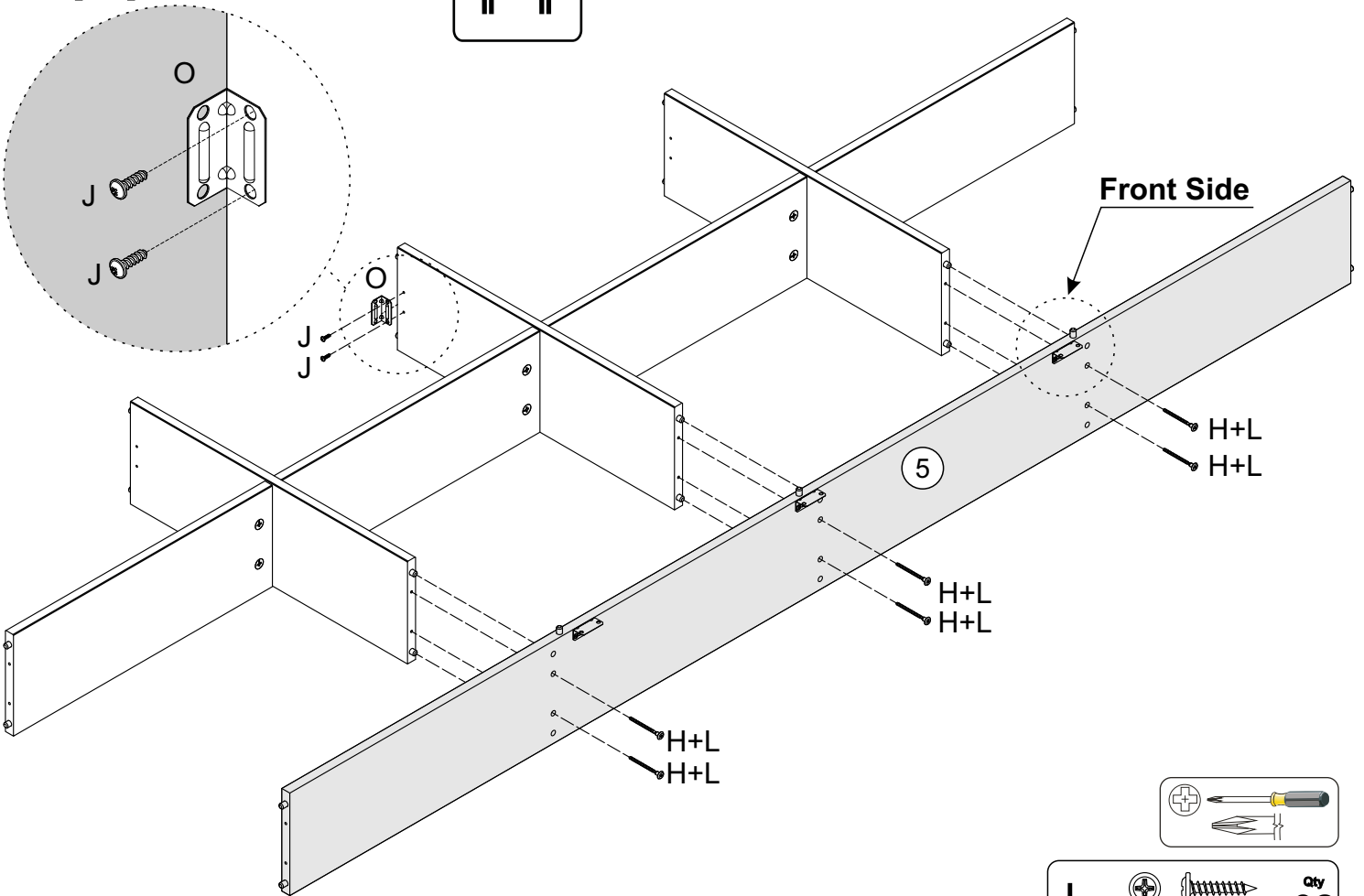
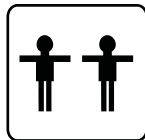
# 14



**J**  Qty **02**  
15/32" Screw

**H**  Qty **06**  
2 3/8" Bolt

**L**  Qty **01**  
3mm Small Allen wrench

**O**  Qty **01**  
L-Bracket

# 15

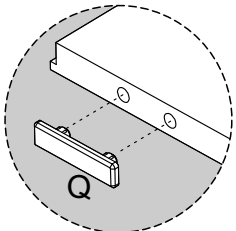
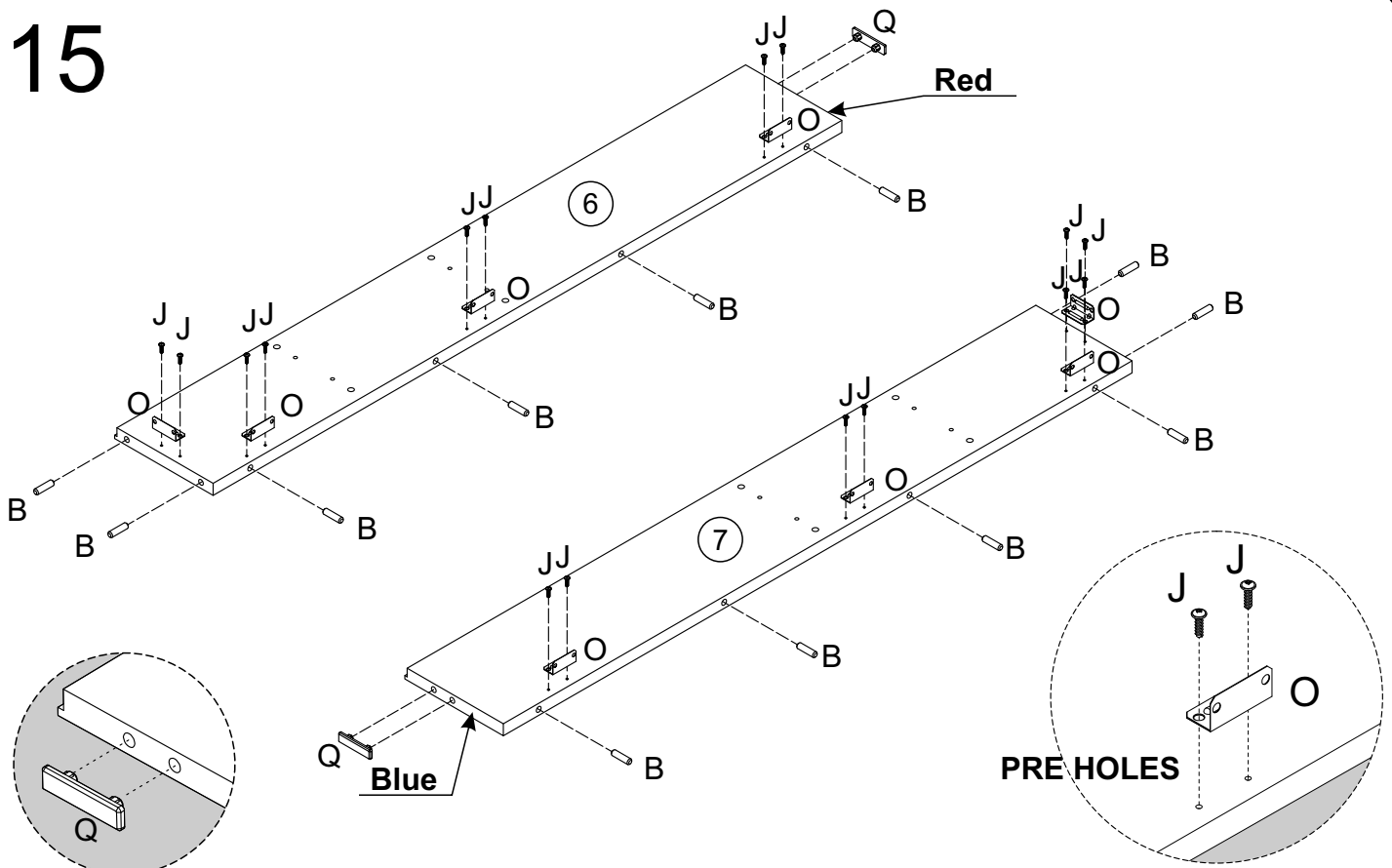

Bottom Side

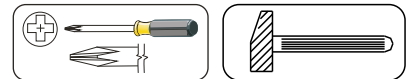

**B**  Qty **12**  
1 3/16" Wooden Dowel

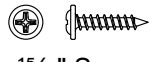
**J**  Qty **16**  
15/32" Screw

**O**  L-Bracket Qty **08**

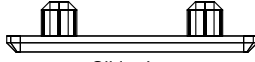
**Q**  Qty **02**  
Slider Legs

# 16

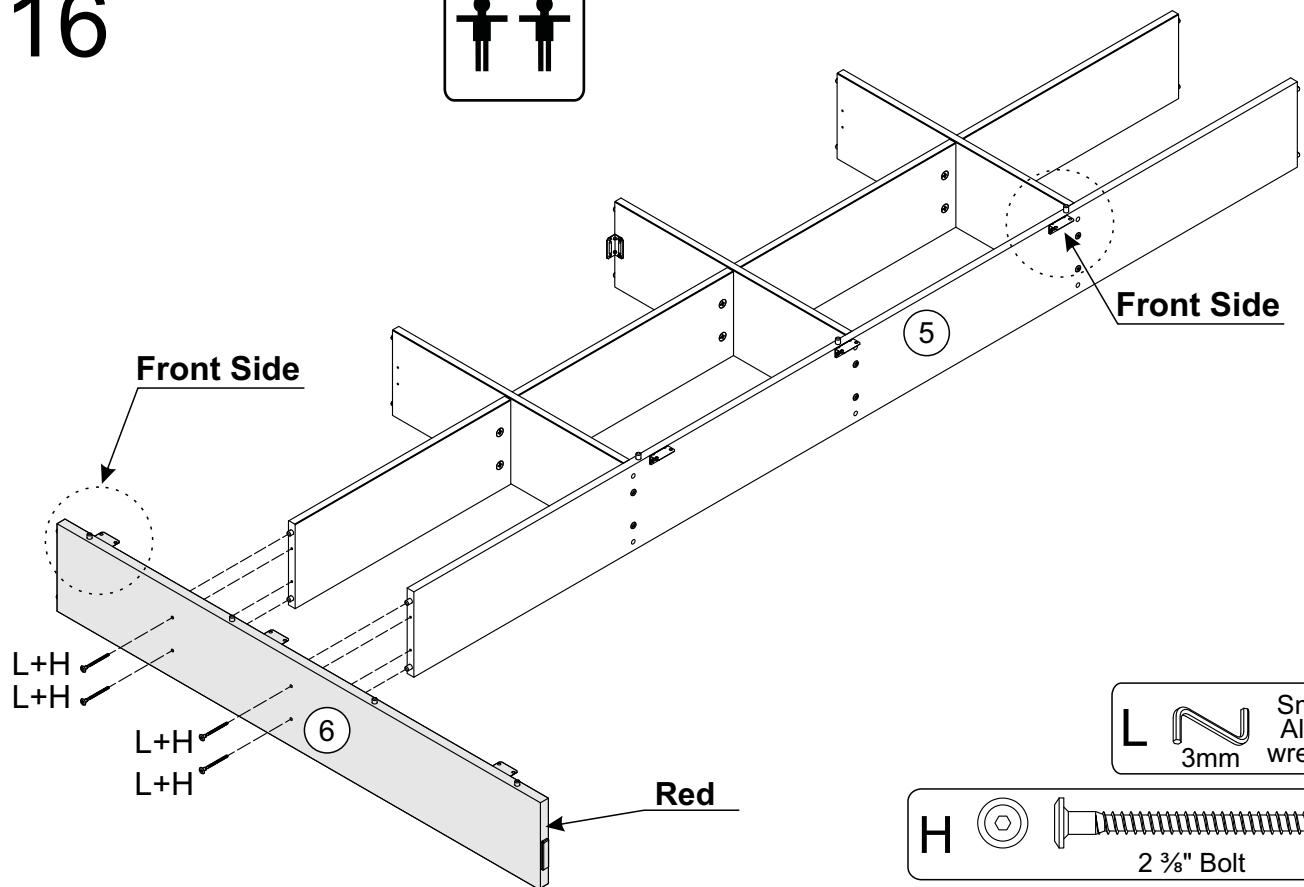
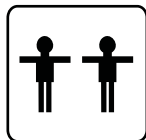

**L**  Small Allen wrench Qty **01**  
3mm

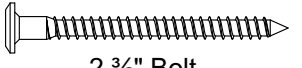
**H**  Qty **04**  
2 3/8" Bolt

# 17

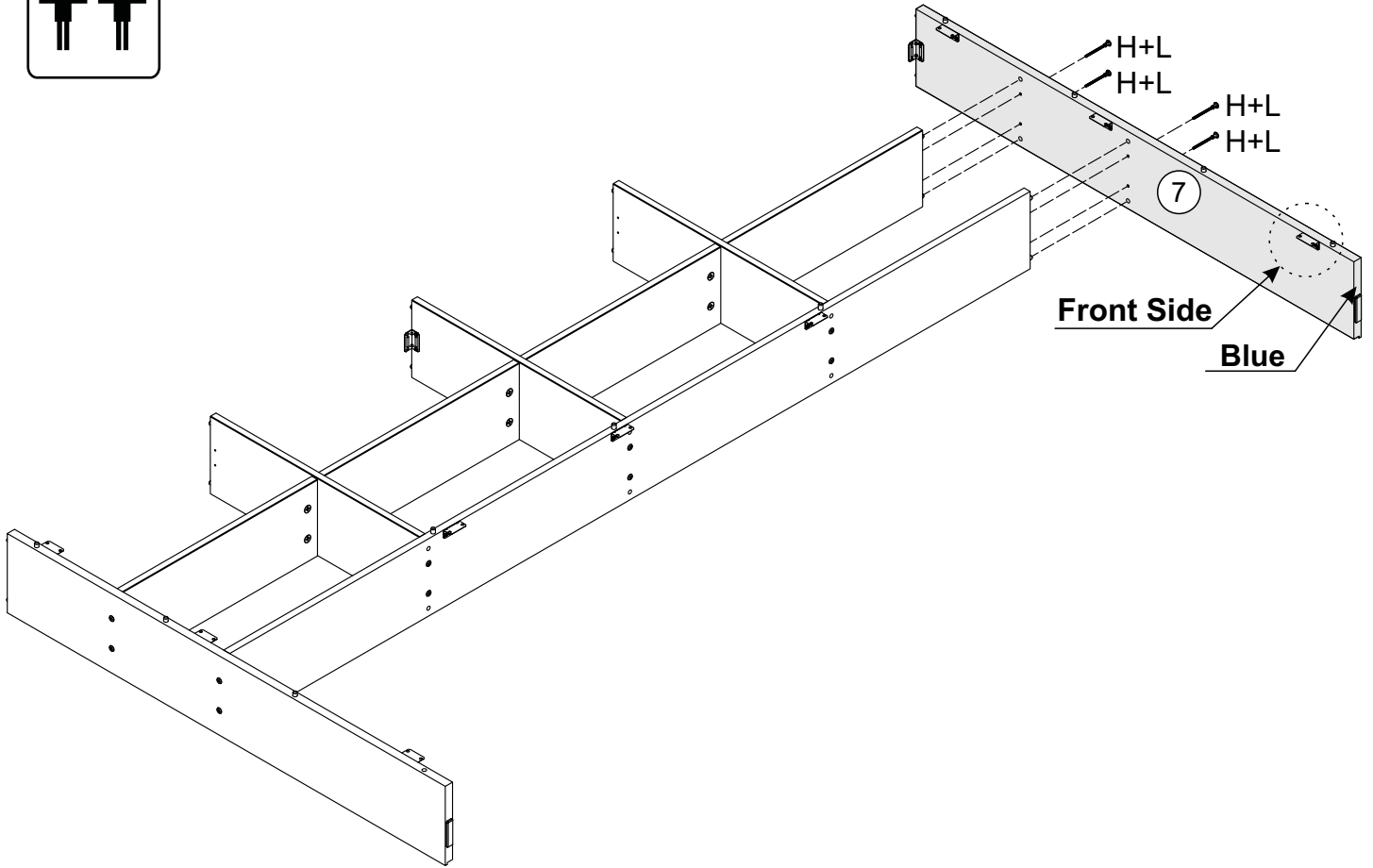

**H**  Qty **04**  
2 3/8" Bolt

**L**  Small Allen wrench Qty **01**  
3mm

# 18

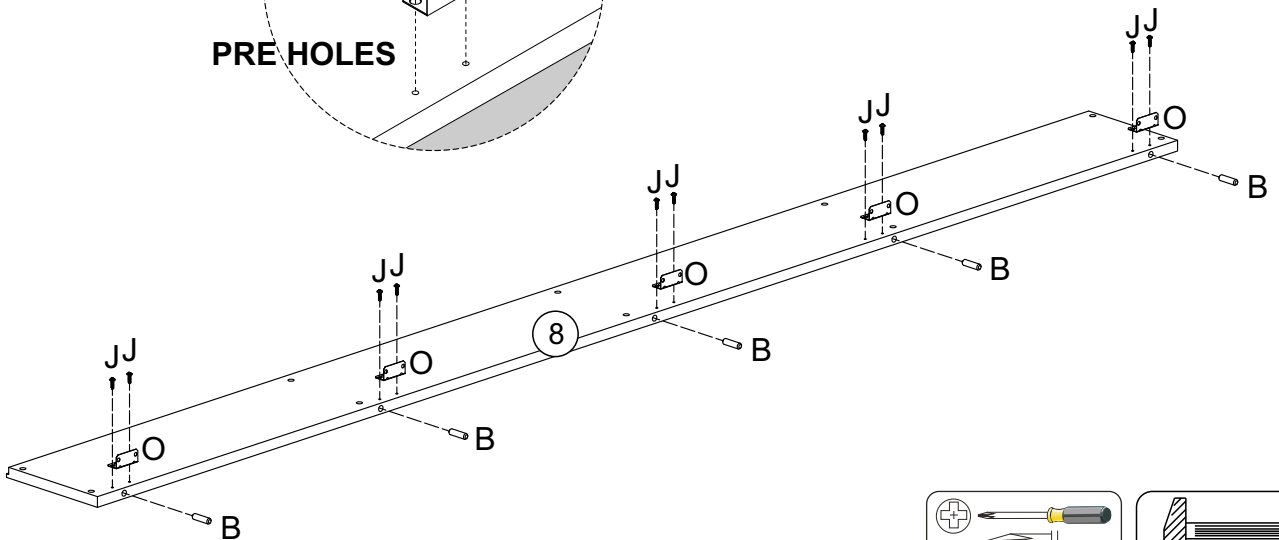
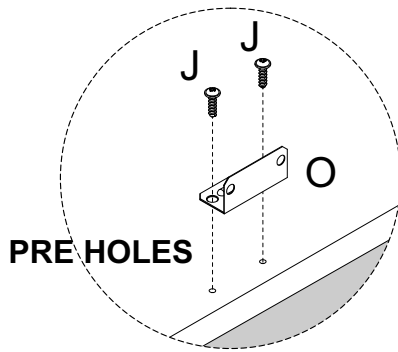

**B**  Qty **05**  
1 3/16" Wooden Dowel

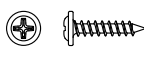
**J**  Qty **10**  
15/32" Screw

**O**  L-Bracket Qty **05**

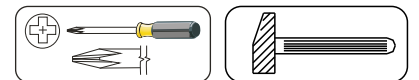



# 19



**KEEP THE BOOKCASE  
ON THE FLOOR  
TILL STEP #28**



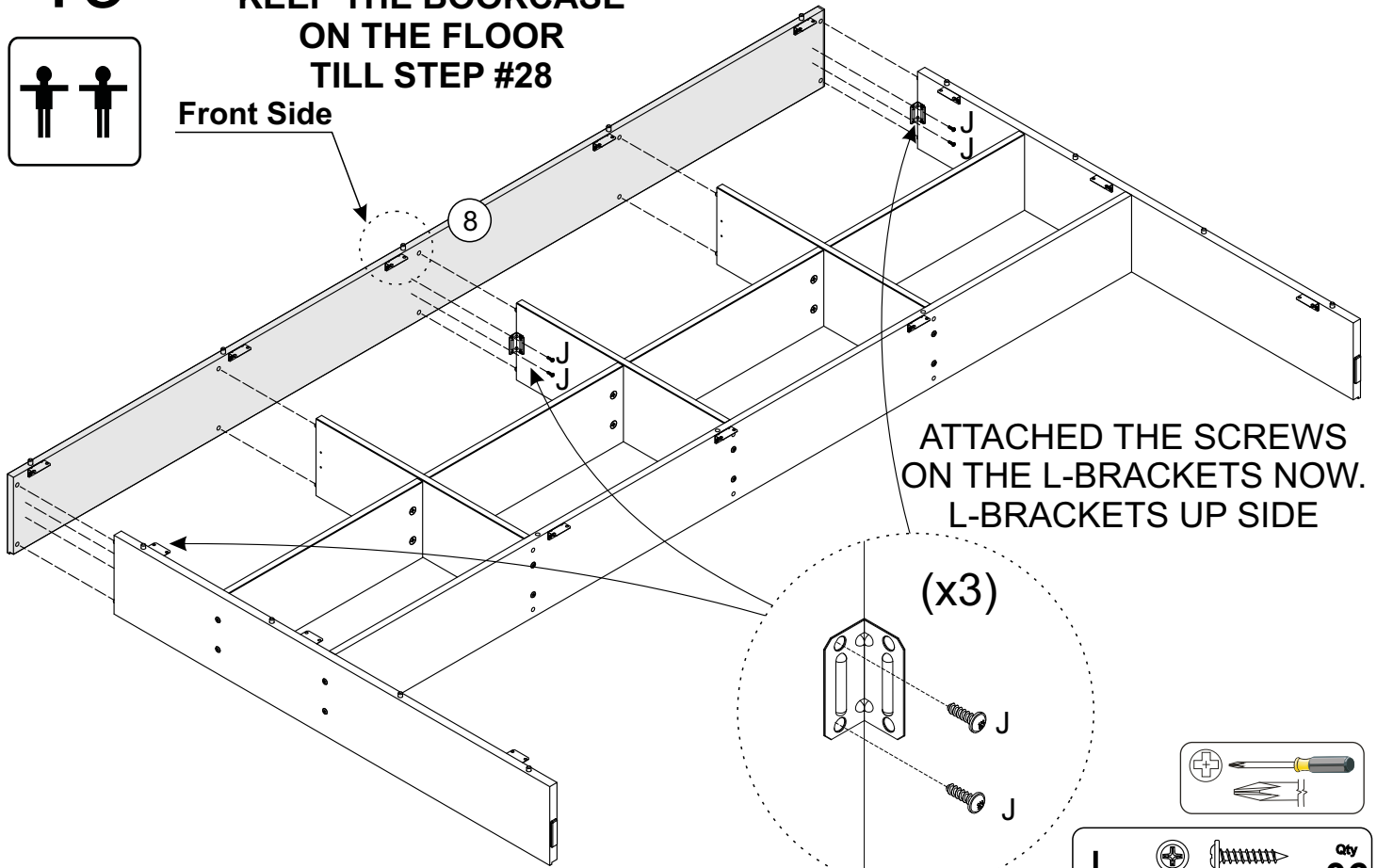

Front Side

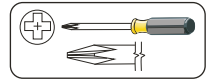
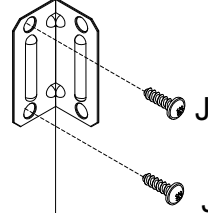

**ATTACHED THE SCREWS  
ON THE L-BRACKETS NOW.  
L-BRACKETS UP SIDE**

(x3)



**J**  **Qty 06**  
1 5/32" Screw

# 20

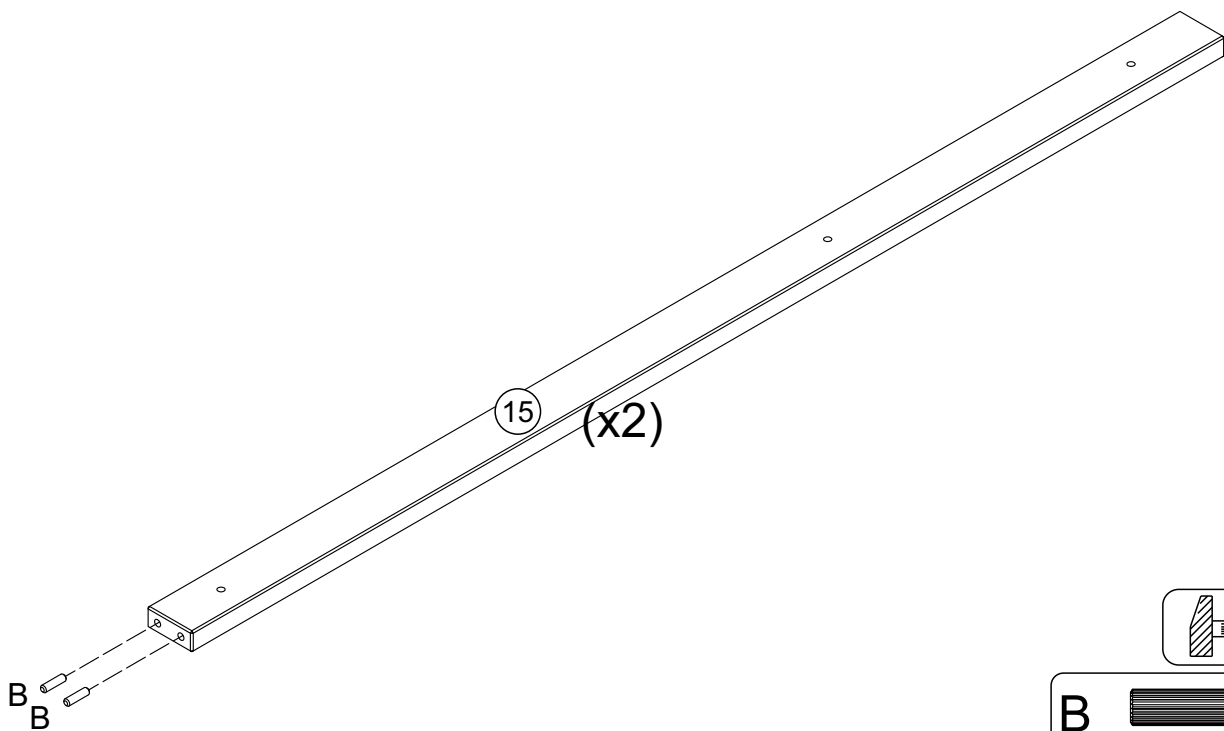

15 (x2)



**B**  **Qty 04**  
1 3/16" Wooden Dowel



**ATTENTIVE TO ATTACHED  
THE L-BRACKET  
ON THIS STEP.**

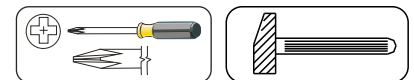
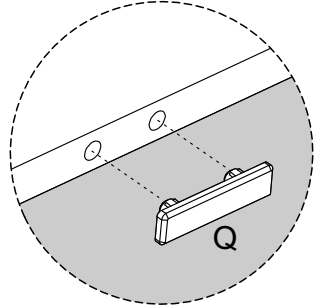
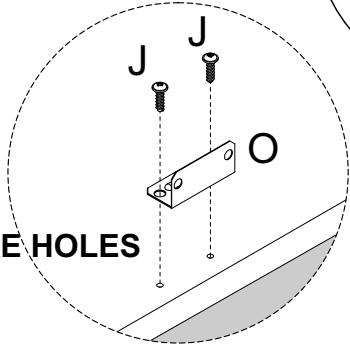
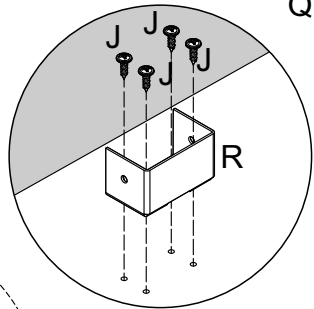
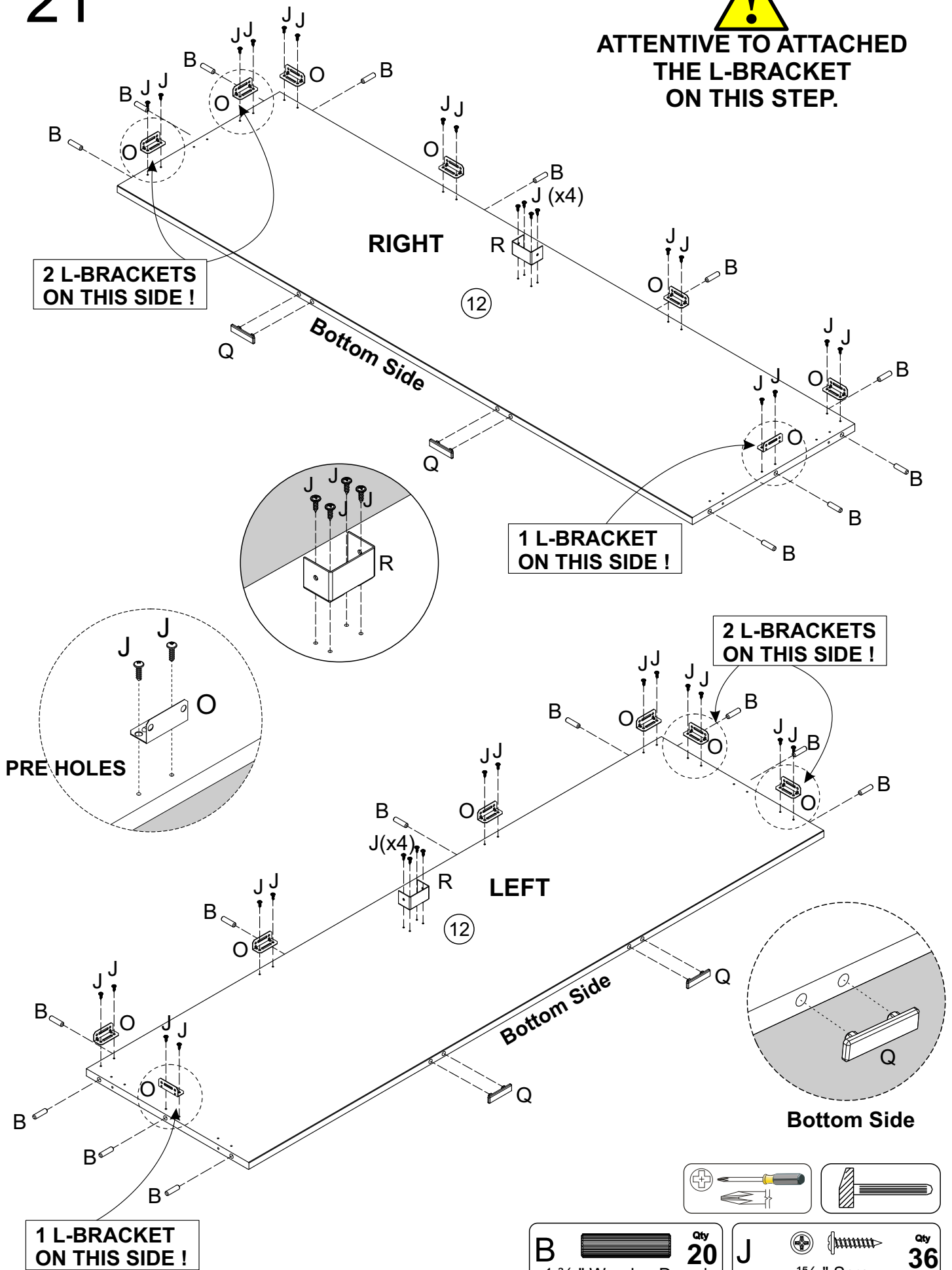

**1 L-BRACKET  
ON THIS SIDE !**

**B** Qty **20**  
1 3/16" Wooden Dowel

**J** Qty **36**  
15/32" Screw

**O** L-Bracket Qty **14**

**Q** Qty **04**  
Slider Legs

**R** Qty **02**

# 22



PLEASE NOTE THAT  
IS 1 LEG EACH PANEL ONLY  
BECAUSE THE PANELS  
WILL BE 1 RIGHT AND  
1 LEFT ON THE ENDS

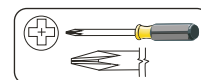
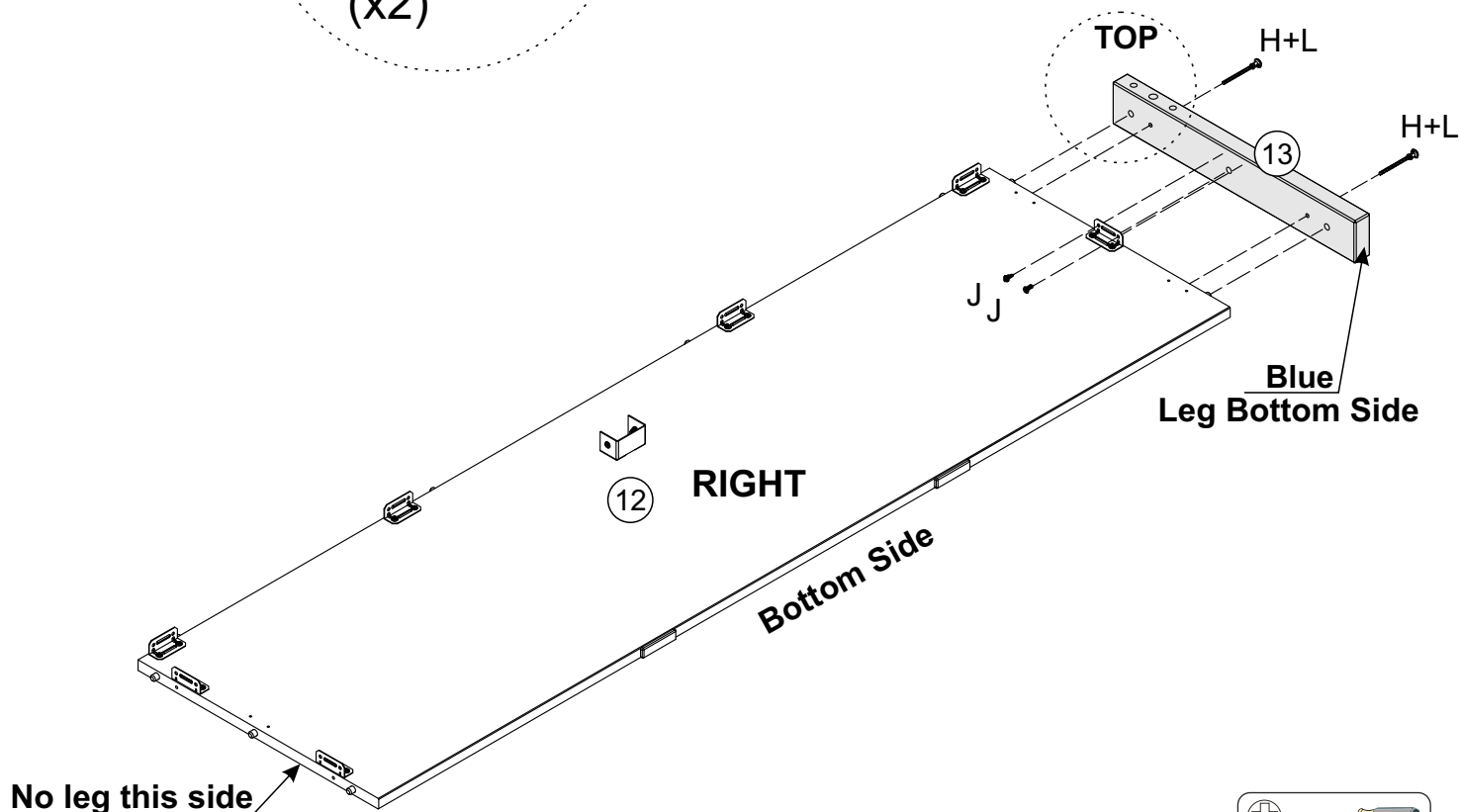
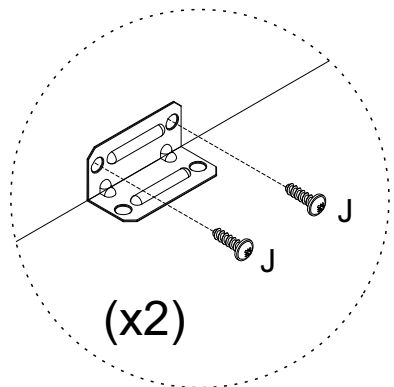
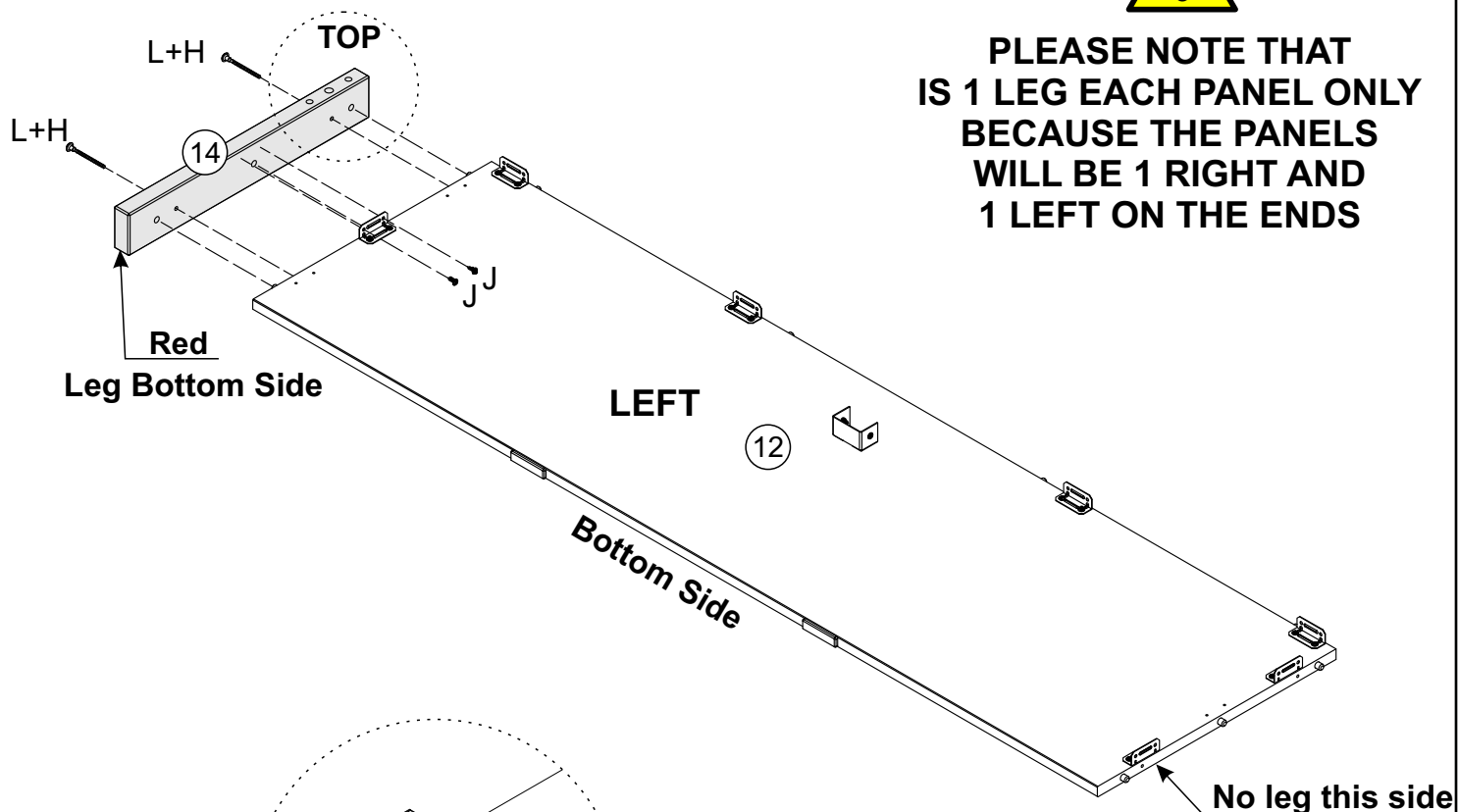

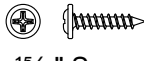
**J**  **Qty 04**  
15/32" Screw

**L**  **Qty 01**  
3mm Small Allen wrench

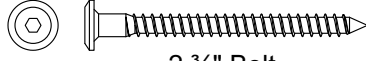
**H**  **Qty 04**  
2 3/8" Bolt

# 23



**WOODEN DOWELS  
THIS SIDE**

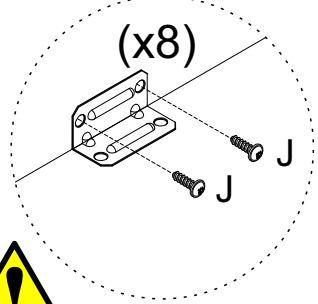
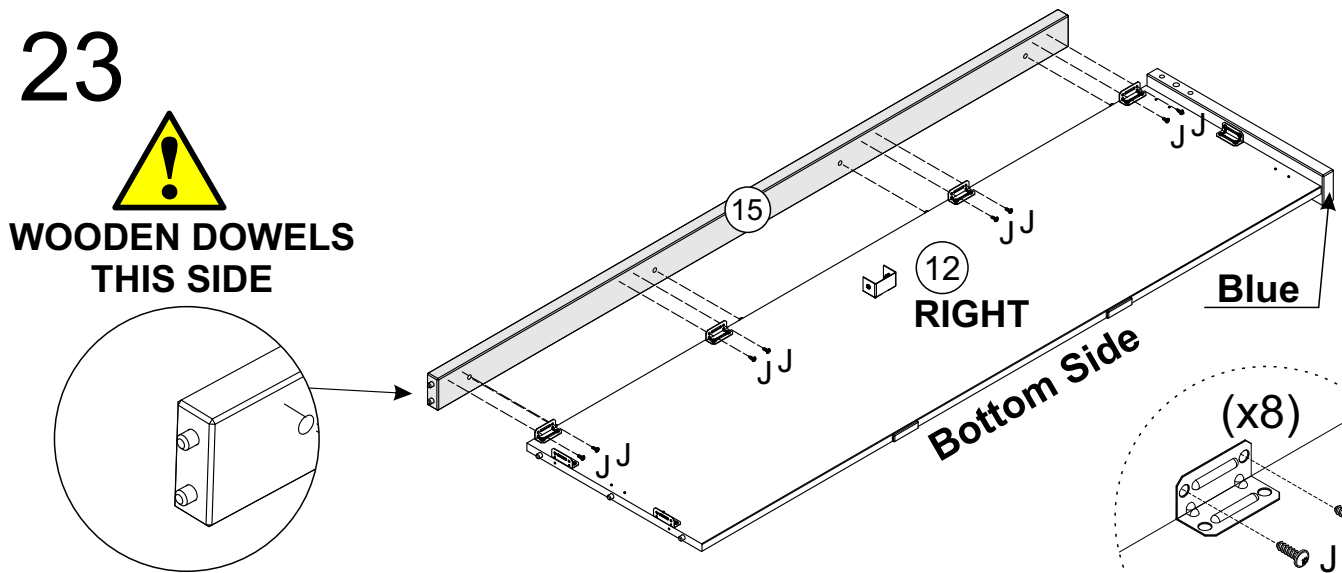
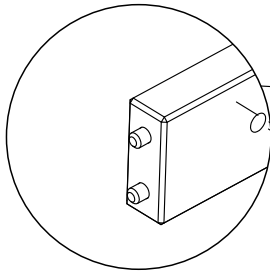

**WOODEN DOWELS  
THIS SIDE**

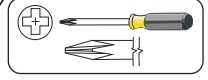
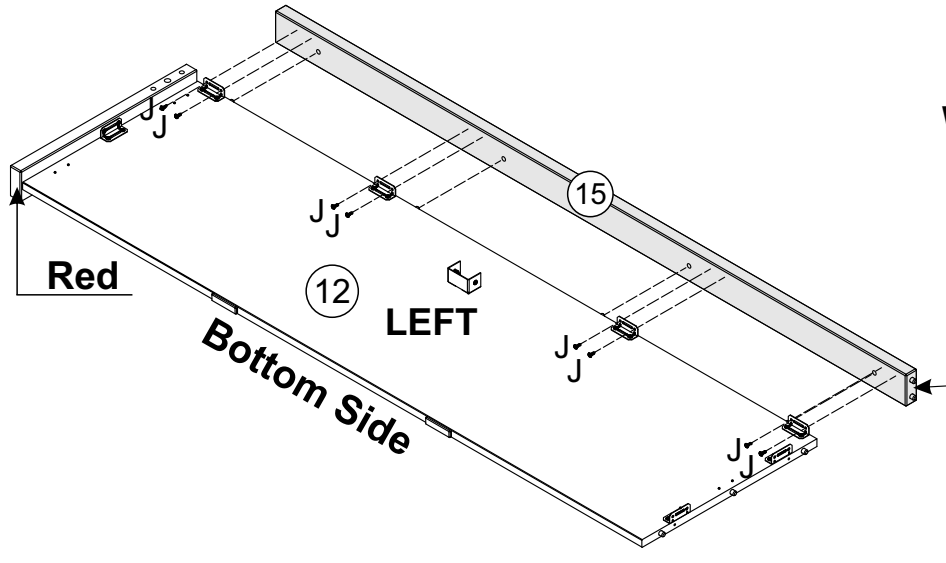
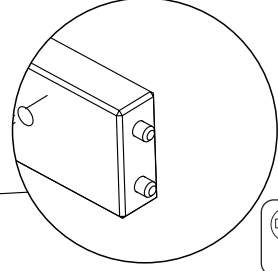

**J**  **15/32" Screw** **Qty 16**

# 24

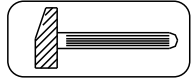
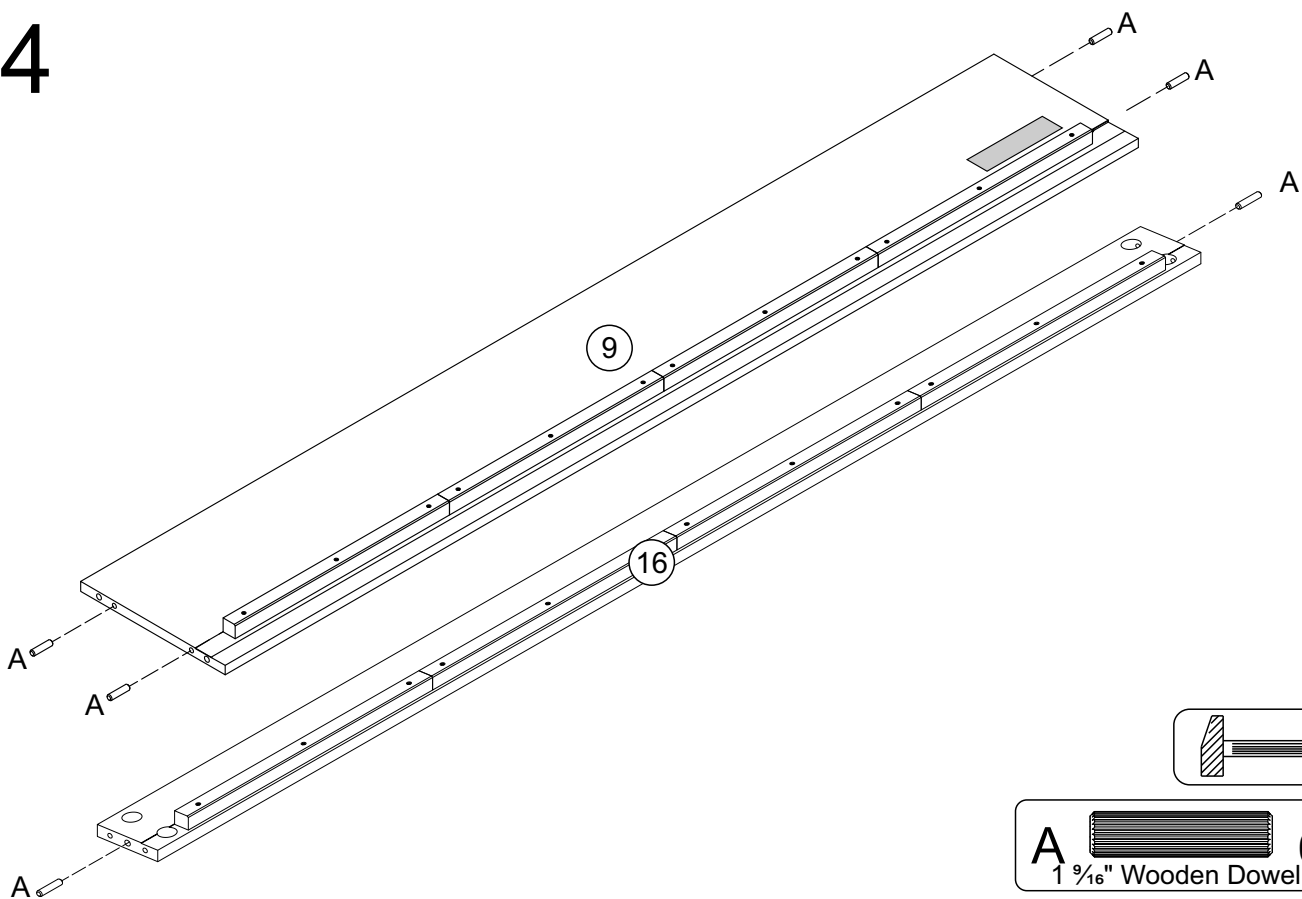

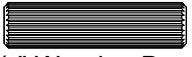
**A**  **Qty 06**  
**1 9/16" Wooden Dowel**



# 25

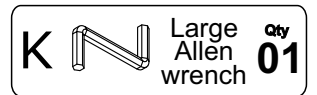
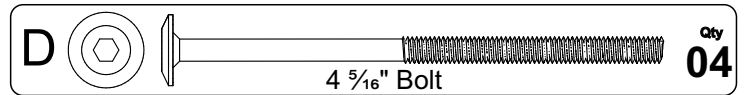
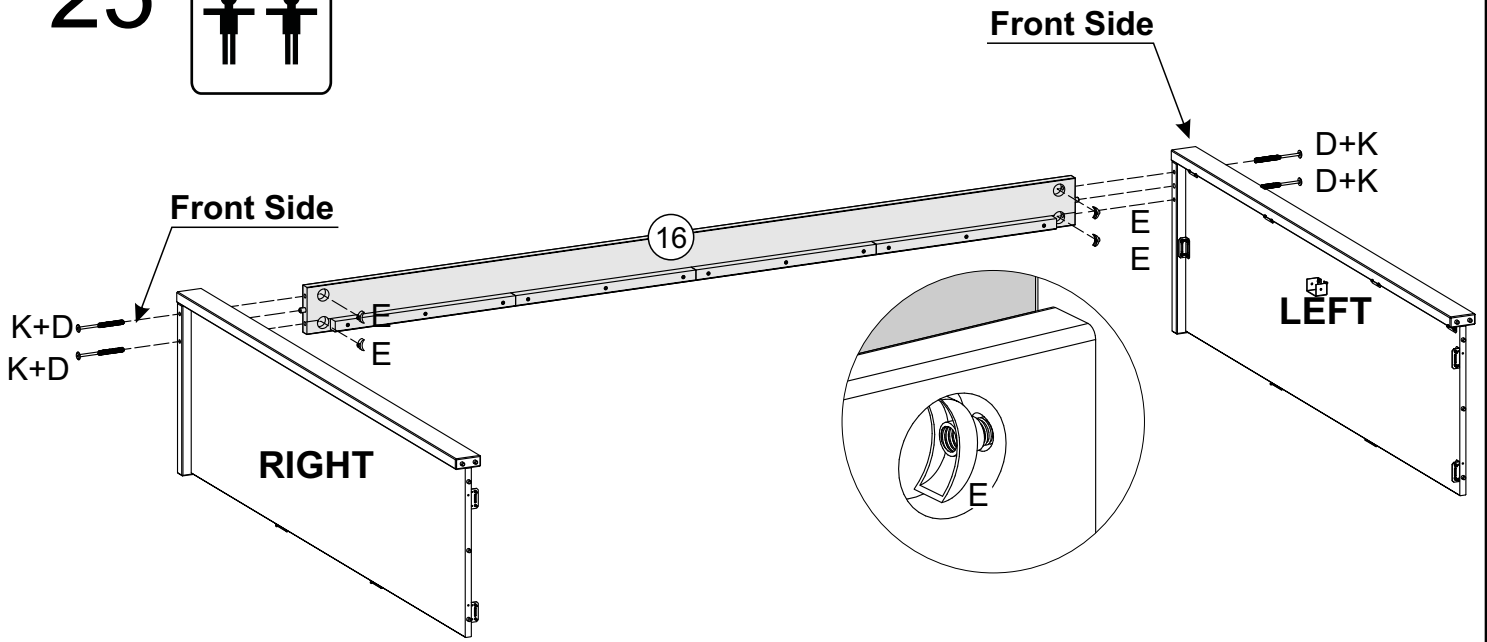

# 26

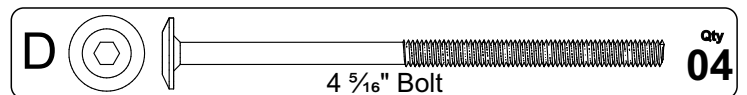
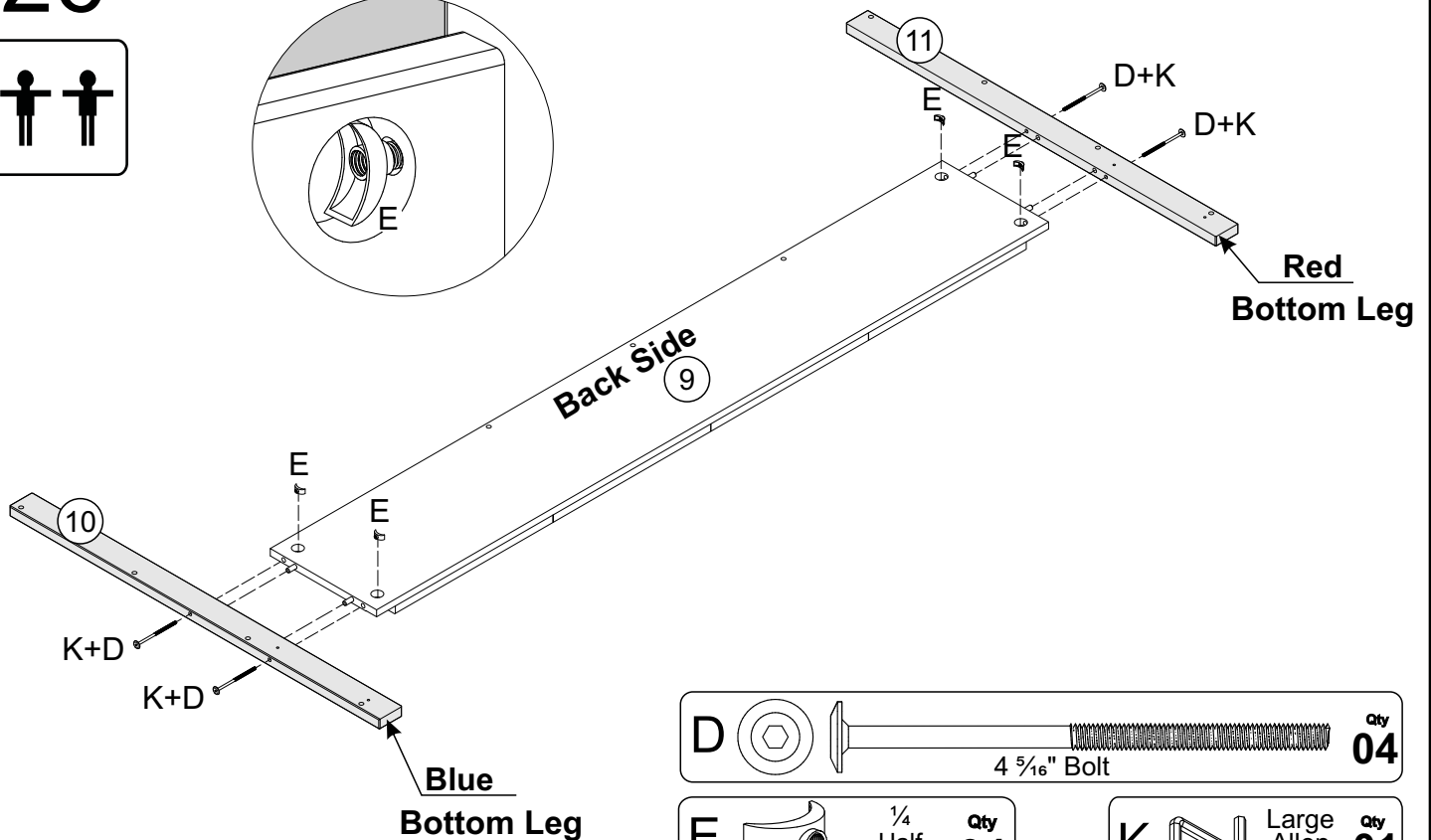
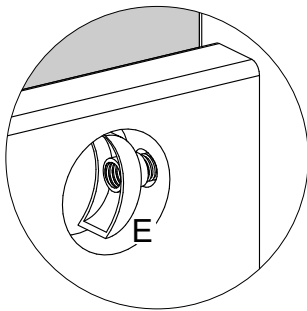

# 27

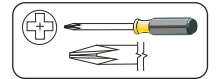
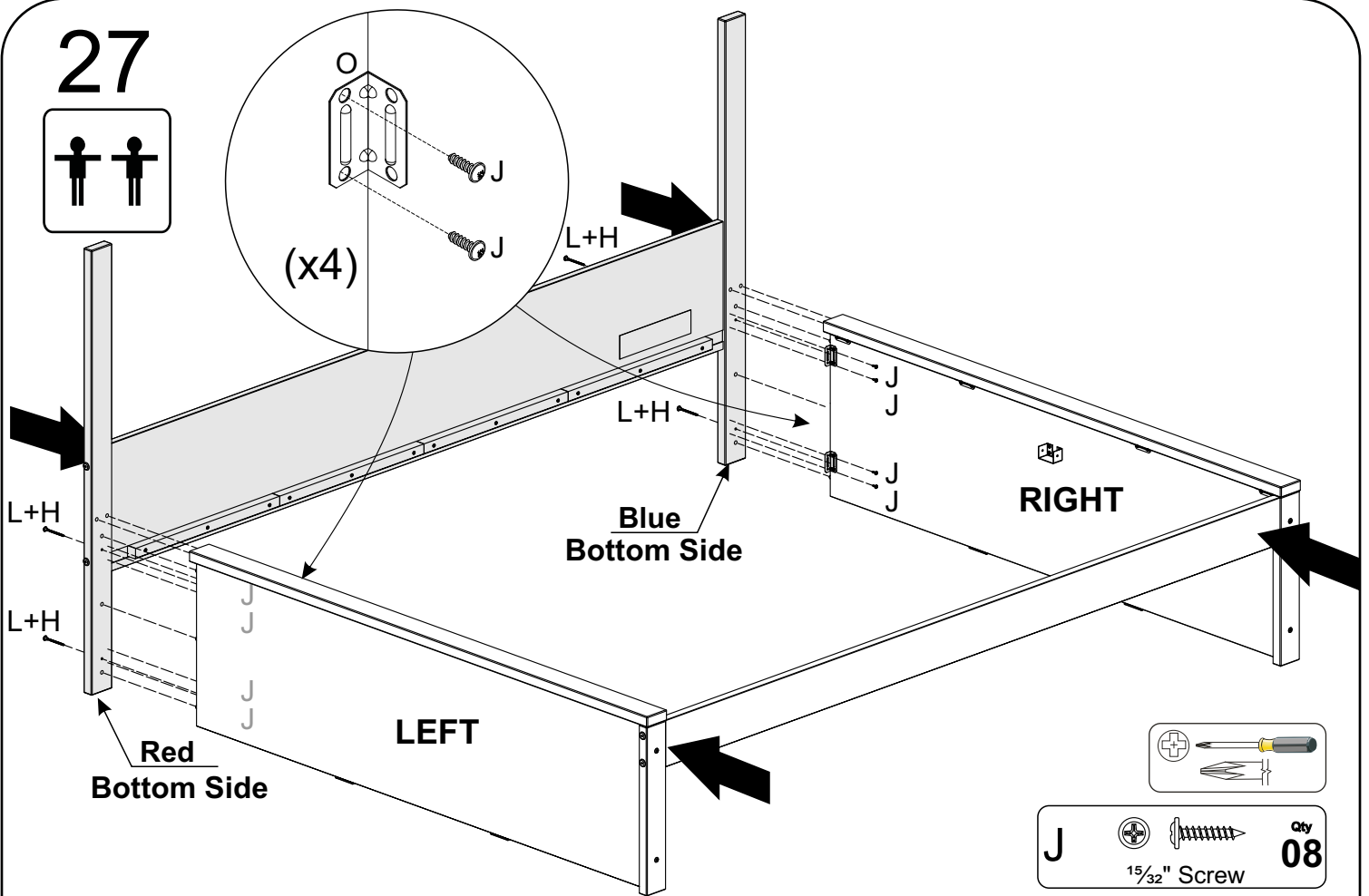
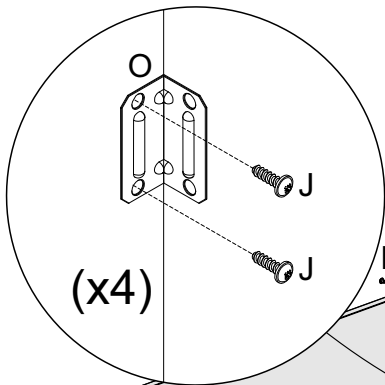

**J** **15/32" Screw** Qty **08**

**L** **3mm Small Allen wrench** Qty **01**

**H** **2 3/8" Bolt** Qty **04**

# 28

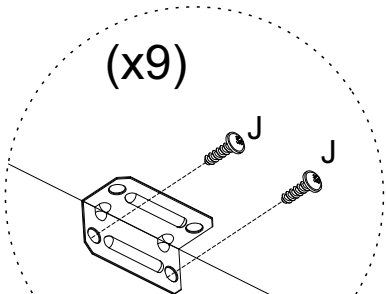
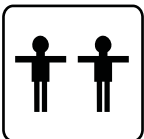

**PLEASE BE CAREFUL IN THIS STEP TO NOT BREAK THE PARTS. YOU NEED TO LIFT THE BOOKCASE OFF THE FLOOR NOW.**

**SCREW THE L-BRACKET ATTACHING THE BOOKCASE TO THE BED!**

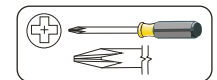
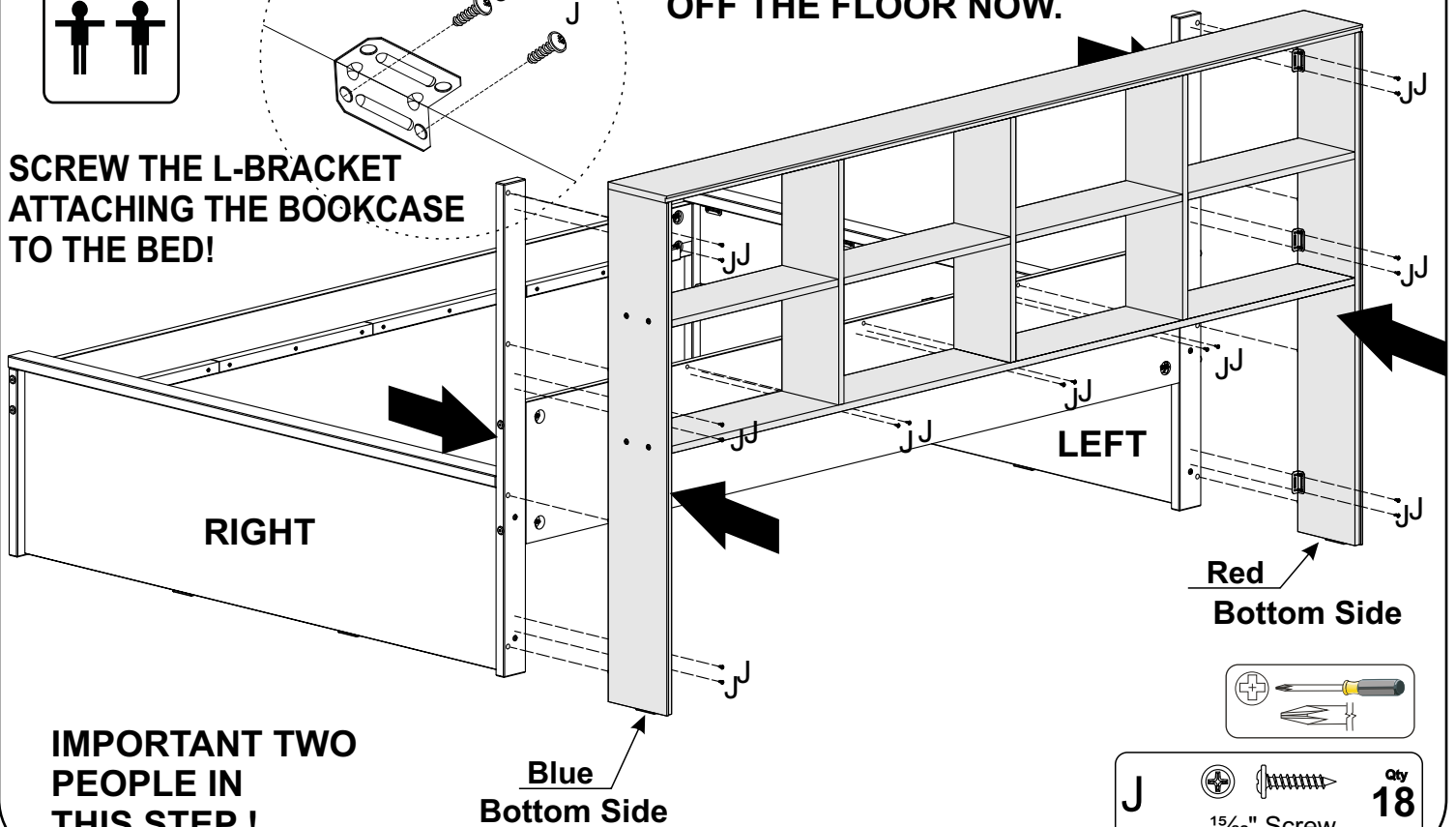

**J** **15/32" Screw** Qty **18**

**IMPORTANT TWO PEOPLE IN THIS STEP !**

# 29

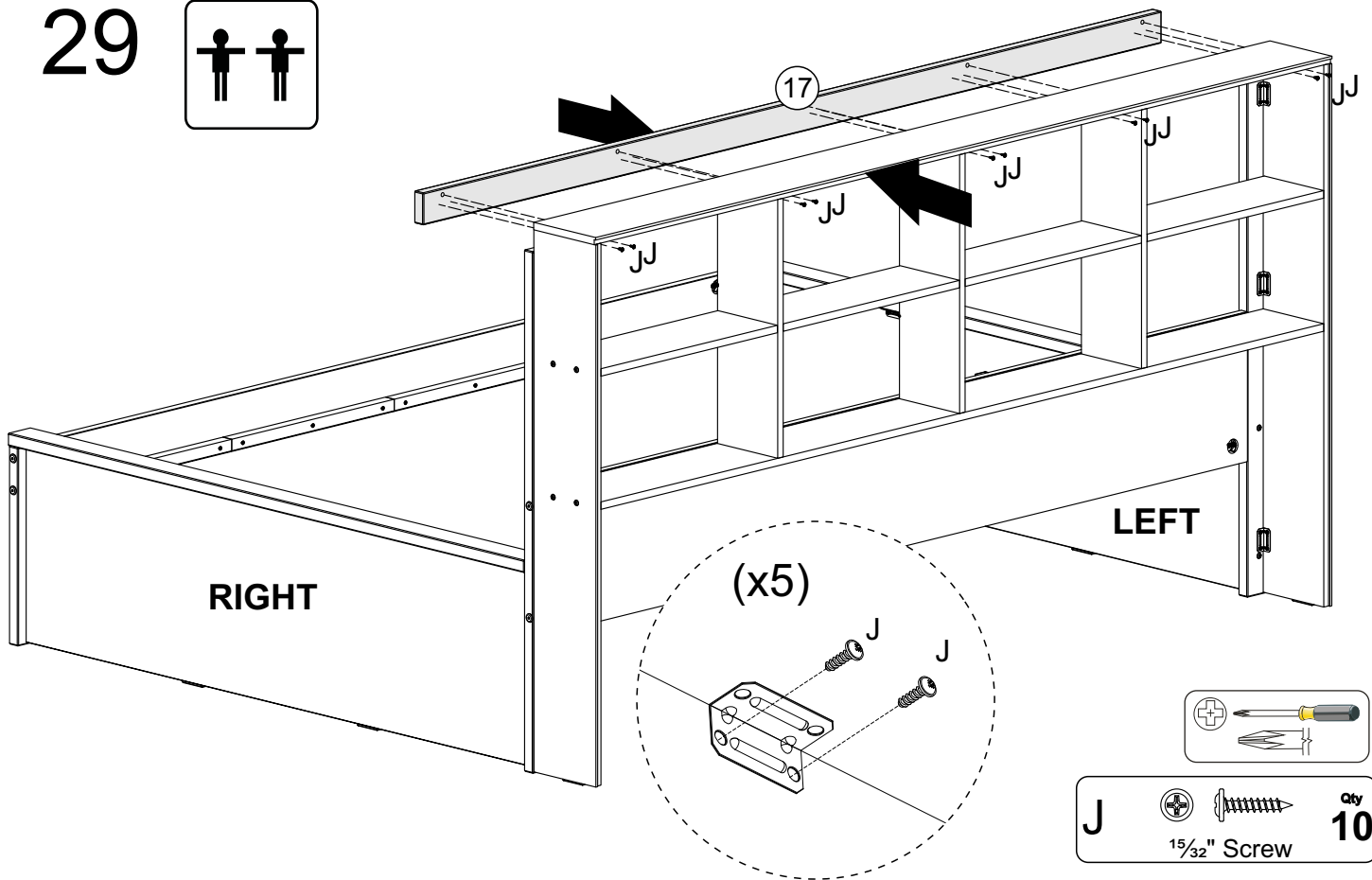

# 30



**PLEASE BE ATTENTIVE TO NOT CAUSE DAMAGE ON THIS STEP ON THE BACK PANELS**

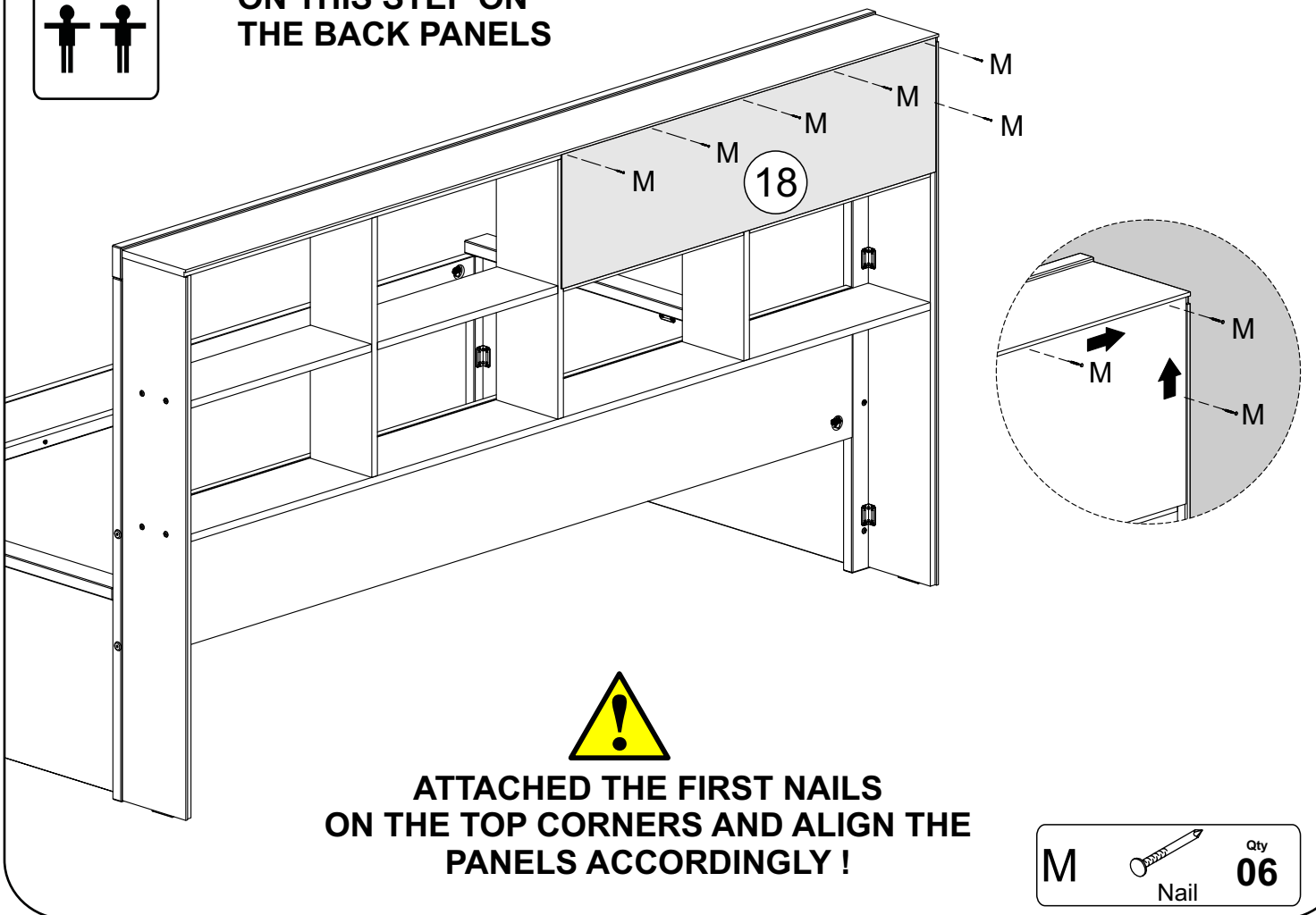

**ATTACHED THE FIRST NAILS ON THE TOP CORNERS AND ALIGN THE PANELS ACCORDINGLY !**

# 31

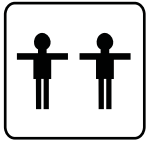
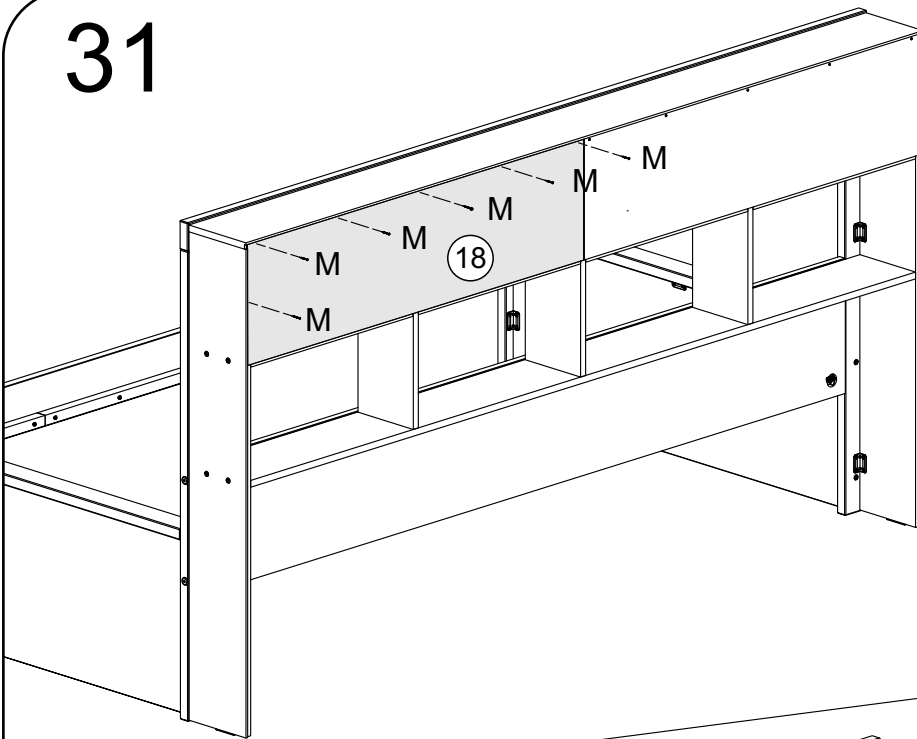

M  Qty **06**  
Nail

# 32

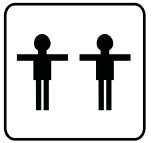
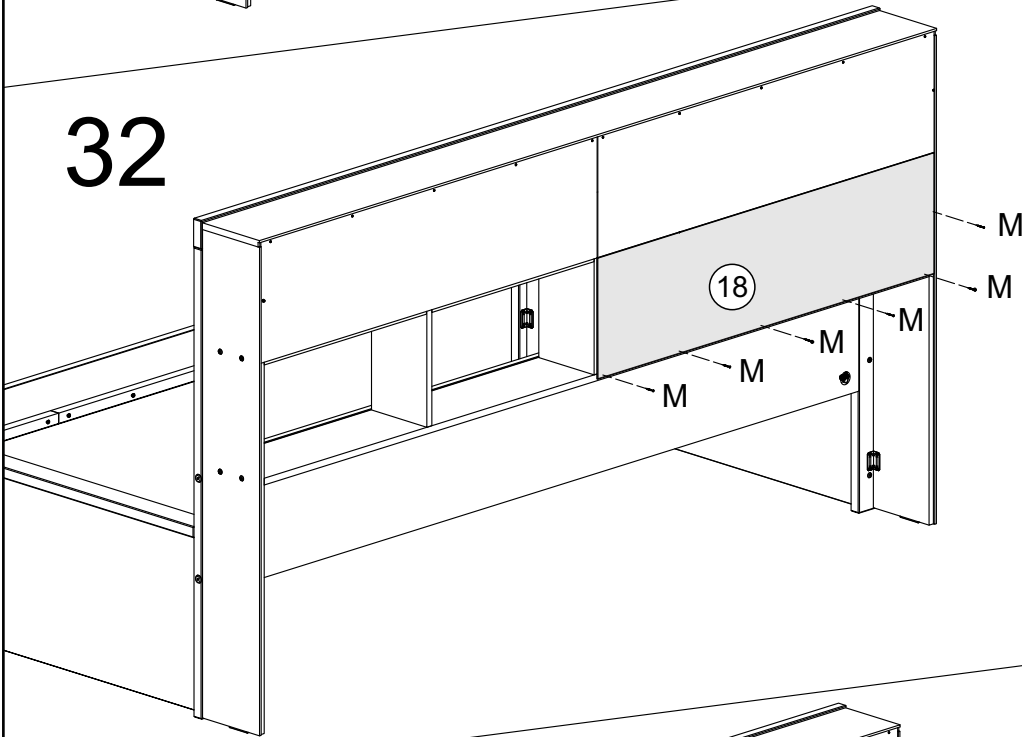

M  Qty **06**  
Nail

# 33

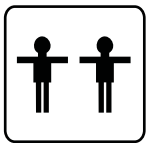
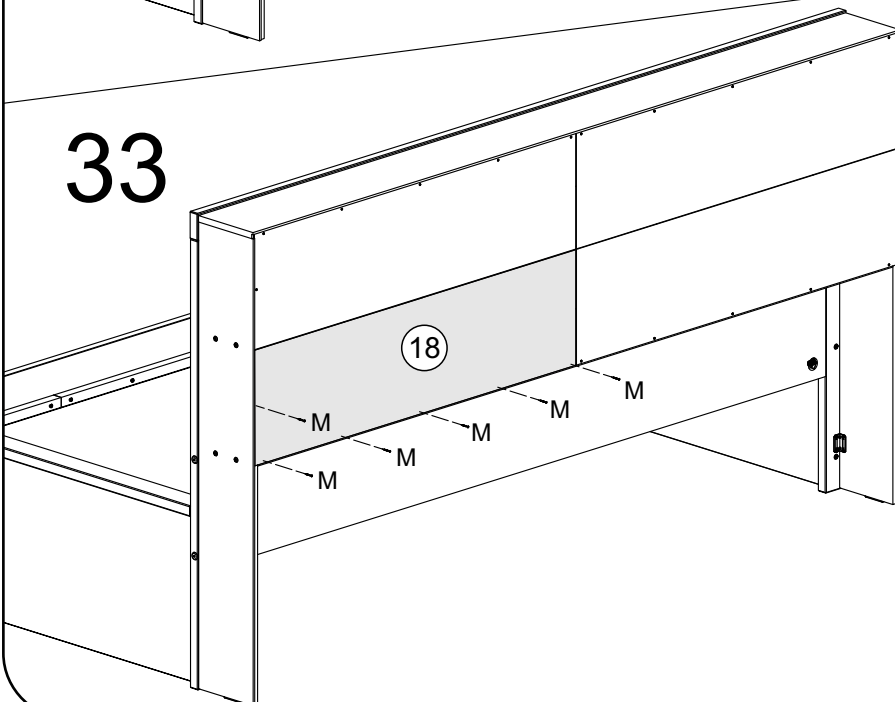

M  Qty **06**  
Nail



# 34

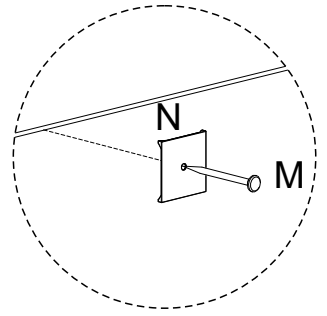
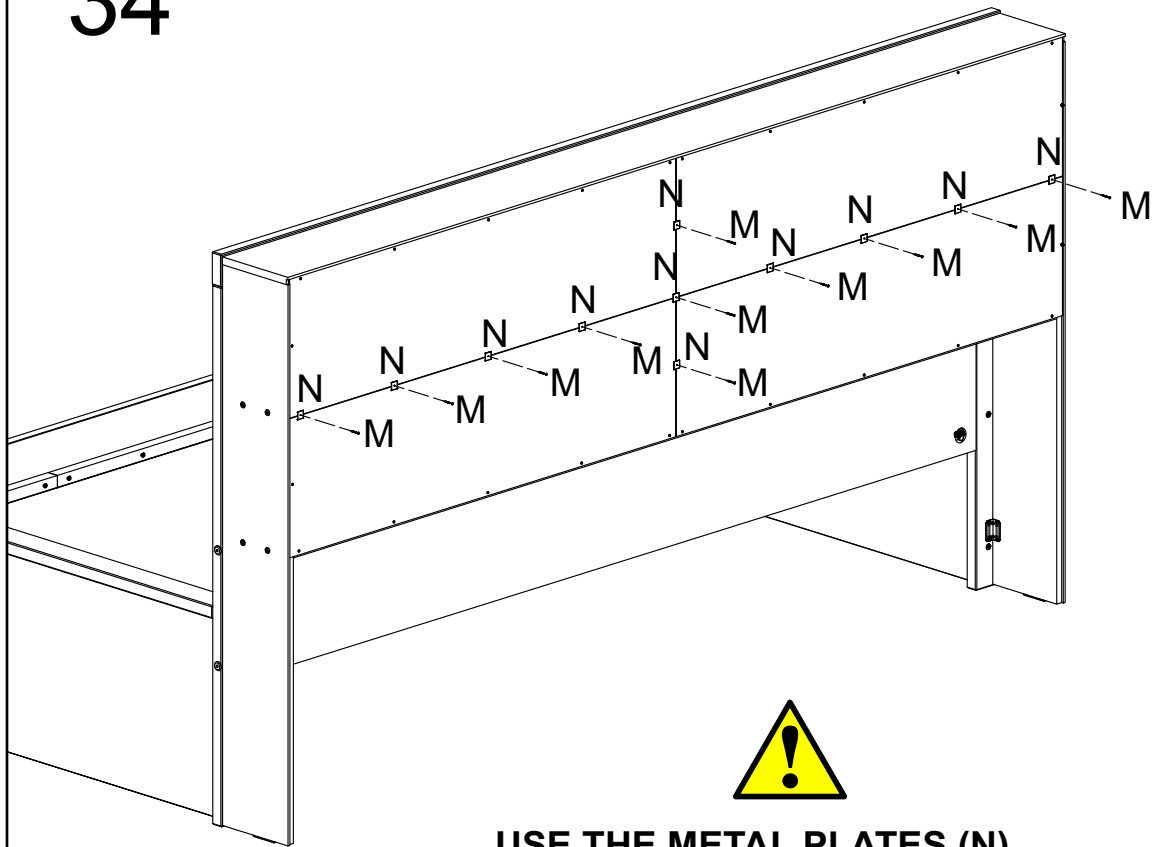

**USE THE METAL PLATES (N)  
ON THE BACK PANELS CONNECTION !**

# 35

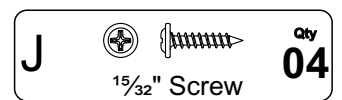
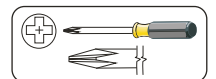
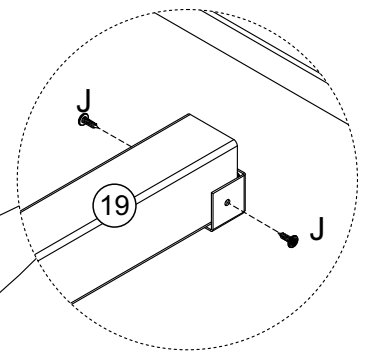
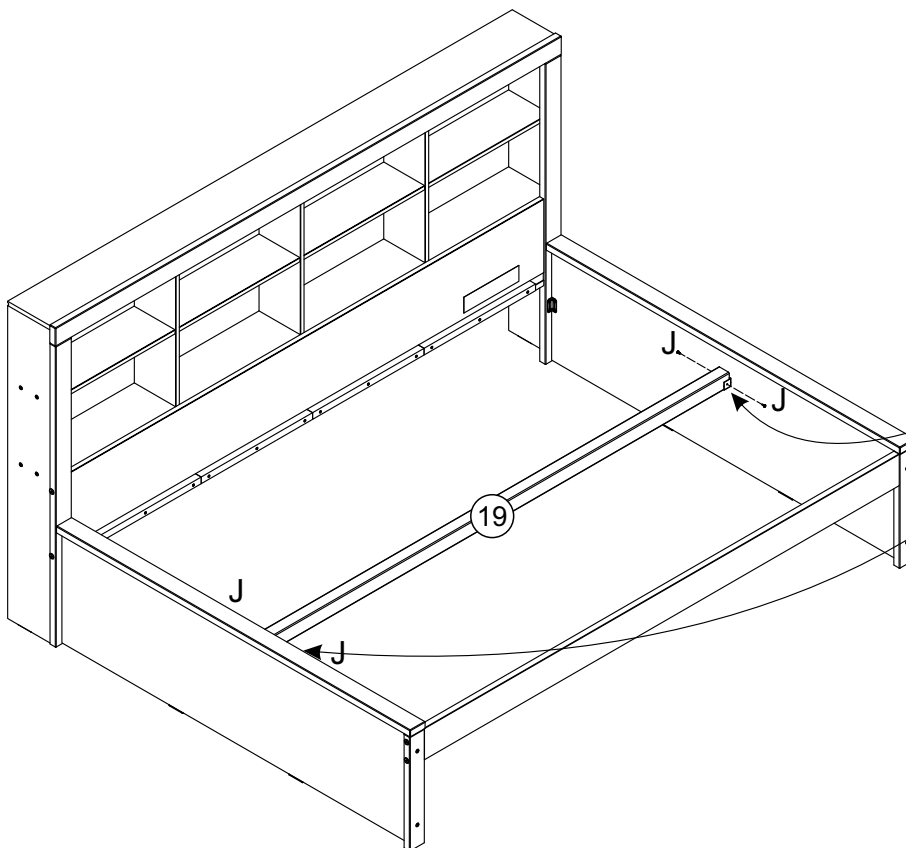

# 36

Attach the first slat using the wood spacer (P) at each end of the headboard.

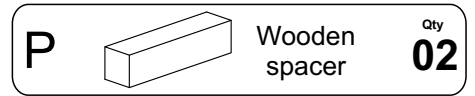
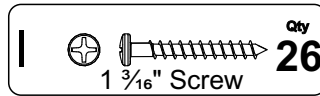
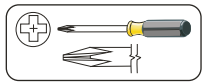
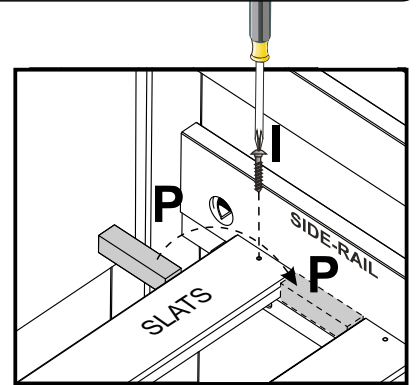
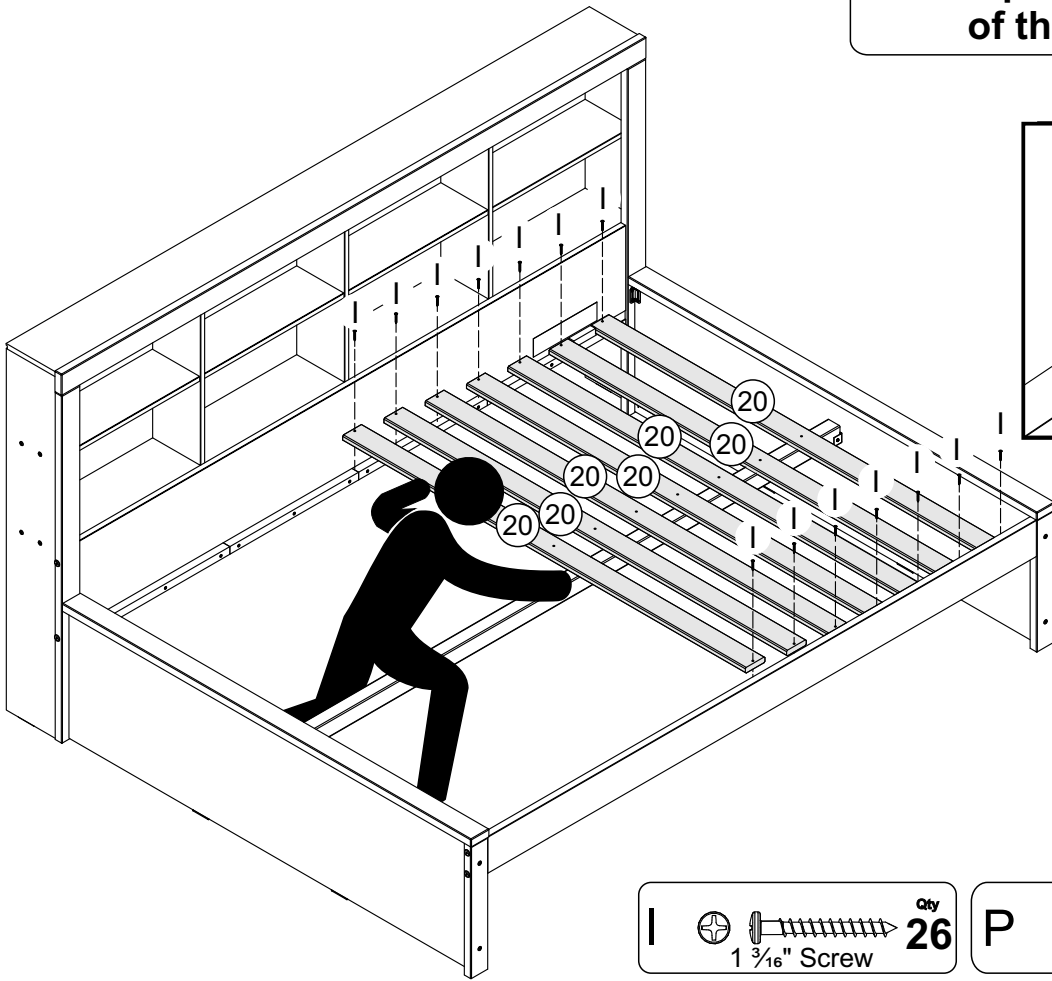

# 37

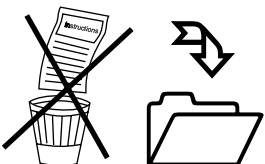
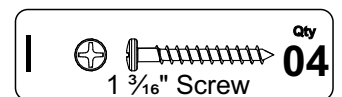
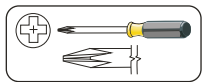
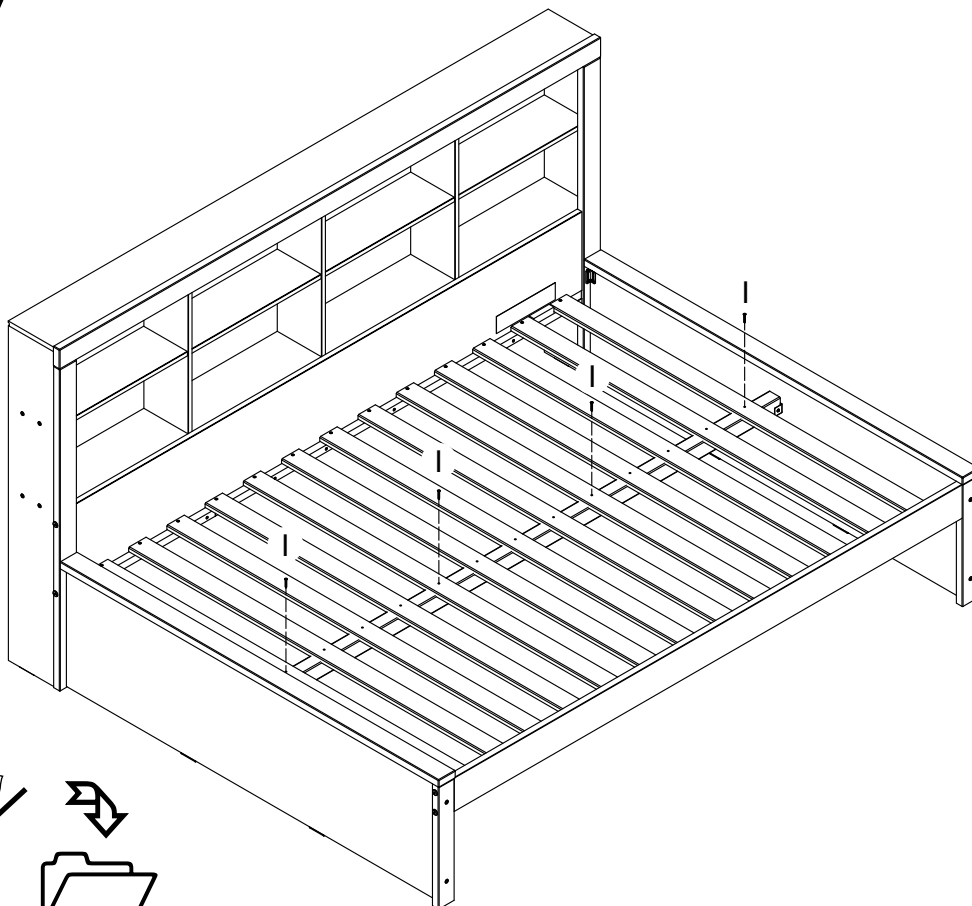

# OPTIONAL COMPONENTS

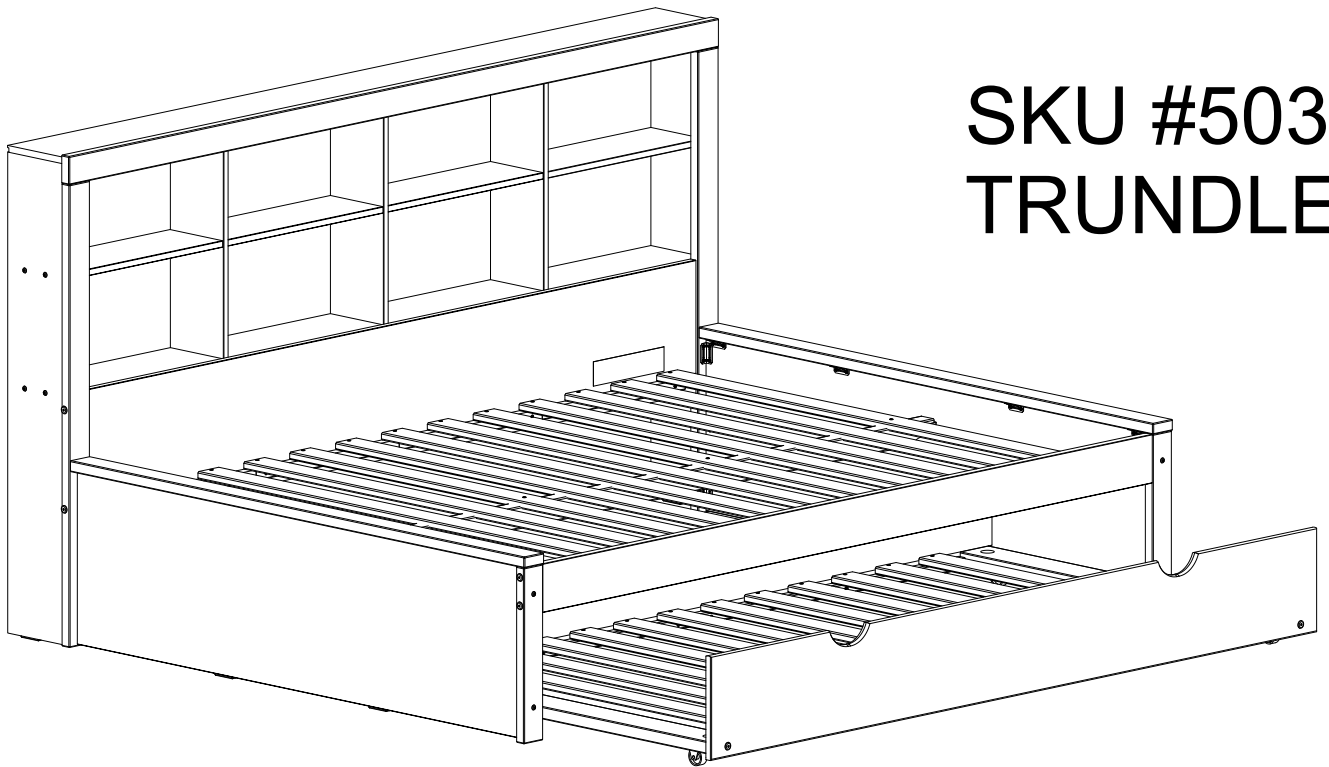

**SKU #503  
TRUNDLE**

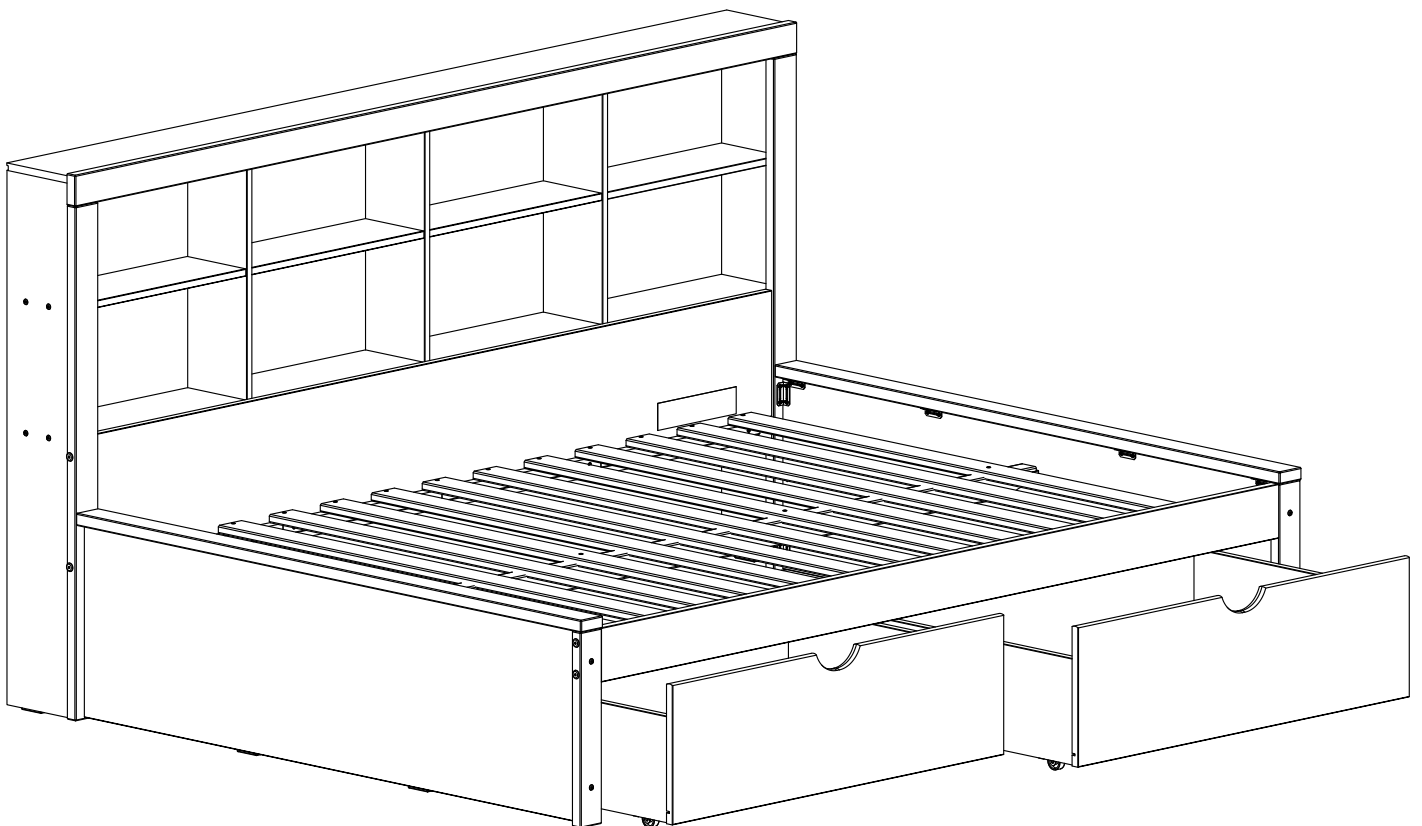

**SKU #505  
DUAL UNDERBED DRAWERS**