

# OWNER'S MANUAL & ASSEMBLY INSTRUCTIONS

## HighBoard 200

Ⓔ Instrucciones de montaje de "HighBoard 200"

Ⓕ Notice de montage du "HighBoard 200"



**CAUTION**  
sharp edges

Gloves must be worn at all times  
to reduce risk of injury!



QUALITY FROM  
A U S T R I A

# IMPORTANT DETAILS BEFORE STARTING ASSEMBLY!



**FOR YOUR SAFETY AND CORRECT ASSEMBLY, PLEASE READ AND FOLLOW ALL INSTRUCTIONS IN THE MANUAL CAREFULLY.**

- ES** ¡Detalles importantes antes de comenzar el montaje! Para su seguridad y correcto montaje, lea y siga atentamente todas las instrucciones del manual.
- FR** Détails importants avant de commencer le montage ! Pour votre sécurité et un montage correct, veuillez lire et suivre attentivement toutes les instructions du manuel.

**ALWAYS WEAR WORK GLOVES, LONG SLEEVES AND SAFETY GLASSES DURING ASSEMBLY AND MAINTENANCE! PARTS CONTAIN SHARP EDGES, PAY ATTENTION TO THEM DURING ASSEMBLY AND DAILY USE.**

- ES** Utilice siempre guantes de trabajo, mangas largas y gafas de seguridad durante el montaje y el mantenimiento. Las piezas contienen bordes afilados, preste atención a ellos durante el montaje y el uso diario.
- FR** Portez toujours des gants de travail, des manches longues et des lunettes de sécurité pendant le montage et l'entretien ! Certaines pièces ont des bords tranchants, faites-y attention pendant le montage et l'utilisation au quotidien.



**KEEP CHILDREN AND PETS AWAY FROM THE WORKSITE, ALL SUPPLIED PARTS, AND PACKAGING MATERIALS DURING ASSEMBLY TO PREVENT ACCIDENTS.**

- ES** Mantenga a los niños y a las mascotas alejados del lugar de trabajo, de todas las piezas suministradas y de los materiales de embalaje durante el montaje para evitar accidentes.
- FR** Pour éviter tout accident, gardez les pièces et les matériaux d'emballage hors de portée des enfants ou des animaux pendant le montage.



**DO NOT ASSEMBLE IN WINDY CONDITIONS! PLEASE MAKE SURE THE PRODUCT IS SECURED IN A STORM-PROOF MANNER WITH THE LID CLOSED!**

- ES** ¡No monte en días ventosos! ¡Asegúrese de que el producto esté asegurado a prueba de tormentas y con la tapa cerrada!
- FR** N'effectuez pas le montage dans des conditions venteuses ! Veillez à ce que le produit soit bien ancré au sol de sorte qu'il résiste aux tempêtes et que le couvercle soit bien fermé !



## ADDITIONAL ASSISTANCE OF ONE PERSON WILL BE REQUIRED FOR SEVERAL ASSEMBLY STEPS.

- (ES)** Se necesitará la ayuda de una persona para varios pasos de montaje.
- (FR)** Vous aurez besoin de l'aide d'une deuxième personne sur plusieurs étapes de montage.

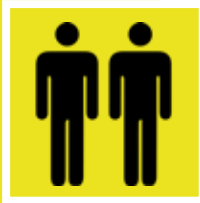

## DIRECT SUNLIGHT MAY CAUSE THE SURFACE OF THE BOX TO BECOME HOT! DURING THE SUMMER, THE INSIDE MAY REACH HIGH TEMPERATURES.

- (ES)** La luz solar directa puede hacer que la superficie de la caja se caliente. Durante el verano, el interior puede alcanzar altas temperaturas.
- (FR)** La lumière directe du soleil peut provoquer un échauffement de la surface du coffre ! L'été, l'intérieur du coffre peut atteindre des températures élevées.

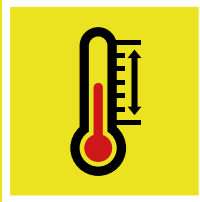

## TO AVOID SCRATCHES DURING ASSEMBLY PLEASE DO NOT PLACE ON HARD OR ABRASIVE SURFACES!

- (ES)** Para evitar arañazos durante el montaje, ¡no coloque las piezas sobre superficies duras o abrasivas!
- (FR)** Pour éviter toute rayure pendant l'assemblage, ne pas poser sur des surfaces dures ou abrasives !

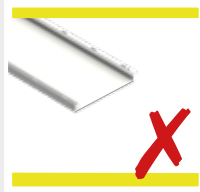

## HANDLING OF DAMAGED OR MISSING PARTS!

Before you begin, be sure to check that all parts are present and free of damage. See parts list on page 4. If parts are damaged, stop assembly and report this to customer service with the appropriate pictures. Do not assemble damaged parts. The parts are considered accepted if you assemble them.

- (ES)** ¡Manipulación de piezas dañadas o faltantes! Antes de empezar, asegúrese de que todas las piezas están presentes y no presentan daños. Consulte la lista de piezas en la página 4. Si las piezas están dañadas, interrumpa el montaje y comuníquelo al servicio de atención al cliente con las fotos correspondientes. No monte las piezas dañadas. Las piezas dañadas se consideran aceptadas si usted las ensambla.
- (FR)** Manipulation de pièces endommagées ou manquantes ! Avant de commencer, assurez-vous que toutes les pièces sont présentes et ne sont pas endommagées. Voir la liste des pièces en page 4. Si des pièces sont endommagées, arrêtez le montage et signalez-le au service client en joignant les photos des pièces concernées. N'assemblez pas de pièces endommagées. Les pièces sont considérées comme acceptées dès lors qu'elles sont assemblées.



## WAIT UNTIL THE END OF THE ASSEMBLY TO TIGHTEN THE NUTS AND BOLTS!

- (ES)** Espere hasta el final del montaje para apretar los tornillos y tuercas.
- (FR)** Attendez la fin de l'assemblage pour serrer les vis et écrous !



## LEVEL SYMBOL! Align the respective parts by using a level.

- (ES)** ¡Símbolo de nivelación! Alinee las piezas respectivas utilizando un nivel.
- (FR)** Symbole de niveau à bulle ! Aligned les pièces respectives à l'aide d'un niveau à bulle.

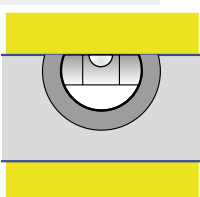

## TO SCALE IMAGES OF THE BOLTS TO BE USED:

(ES) Imágenes a escala de los tornillos a utilizar:

(FR) Vis à utiliser, échelle 1:1

SCALE 1:1

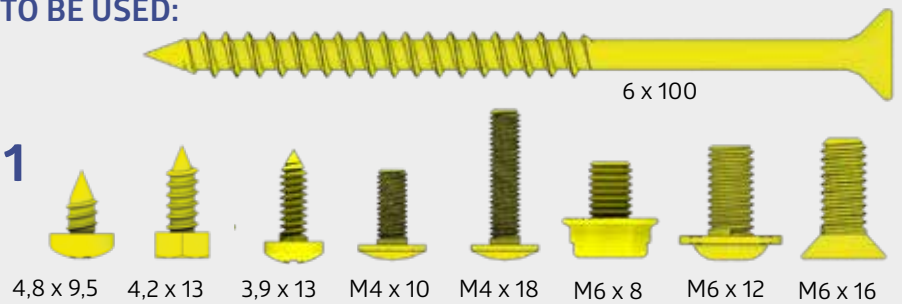

## FOR EASIER ASSEMBLY, YOU CAN POSITION THE NUT AND METRIC WASHER IN THE NUT DRIVER.

(ES) Para facilitar el montaje, puede colocar la tuerca y la arandela en la boca del destornillador.

(FR) Pour faciliter le montage, veuillez positionner directement la rondelle et l'écrou directement sur le tournevis.

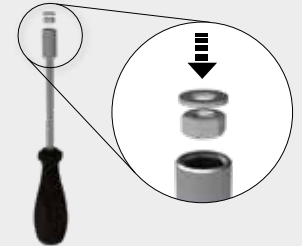

## QR CODE: INDIVIDUAL STEPS CAN BE VIEWED VIA VIDEO.

For certain assembly steps, you can start a YouTube video via the designated QR code which shows you the corresponding assembly step.

(ES) Código QR: Los pasos individuales del montaje se pueden ver en vídeo. Para determinados pasos de montaje, puede iniciar un vídeo de YouTube a través del código QR designado que le mostrará el paso de montaje correspondiente.

(FR) Code QR : vous pouvez voir certaines étapes en vidéo. Pour certaines étapes de montage, une vidéo explicative est disponible sur YouTube via le code QR.



## CARE AND MAINTENANCE!

**Do not store aggressive substances ex. Chlorine or rock salt! Remove suntan lotion or any other creams with soap and water! Do not use abrasive cleaning agents! Lubricate the lock once a year! Check bolts and nuts regularly and retighten as necessary!**

(ES) ¡Cuidado y mantenimiento! No almacene sustancias agresivas como por ejemplo cloro o sal de roca. Elimine la loción bronceadora o cualquier otra crema con agua y jabón. ¡No utilice productos de limpieza abrasivos! Lubrique la cerradura una vez al año. Compruebe regularmente los tornillos y las tuercas y vuelva a apretarlos si es necesario.

(FR) Entretien et maintenance ! Ne pas stocker de substances agressives (chlore, sel, etc.) ! Enlever les traces de crème solaire ou d'autres crèmes avec de l'eau et du savon ! Ne pas utiliser de produits de nettoyage abrasifs ! Huiler la serrure une fois par an ! Vérifiez régulièrement les vis et écrous et resserrez-les si nécessaire !

## NOT INTENDED FOR USAGE BY CHILDREN.

**To avoid risk of suffocation, do not allow children to play inside the box. Children could become locked inside which could lead to death.**

(ES) No está previsto que lo utilicen los niños. Para evitar el riesgo de asfixia, no permita que los niños jueguen dentro de la caja. Los niños podrían quedar encerrados en el interior, lo que podría provocarles la muerte.

(FR) N'est pas destiné à être utilisé par des enfants. Pour éviter tout risque de suffocation, ne laissez pas les enfants jouer à l'intérieur de la boîte. Les enfants pourraient s'enfermer à l'intérieur, ce qui pourrait entraîner la mort.



## PRODUCT LIABILITY CLAUSE

**Biohort shall not be responsible for any injury caused to the user during assembly, usage and possession.**

(ES) Cláusula de responsabilidad del producto. Biohort no se hace responsable de los daños causados al usuario durante el montaje, el uso y la posesión.

(FR) Clause de responsabilité du produit. Biohort ne peut être tenu responsable des blessures causées à l'utilisateur lors du montage, de l'utilisation et de la possession.

# 1 LID PACKAGE

Paquete de tapa · Colis du couvercle

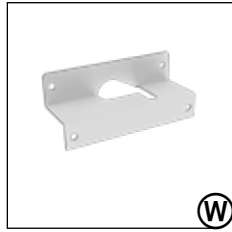
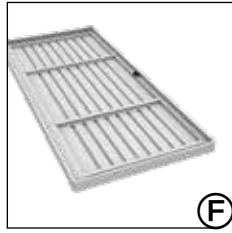
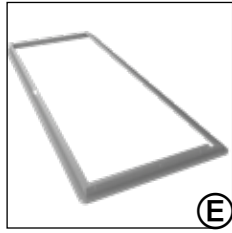
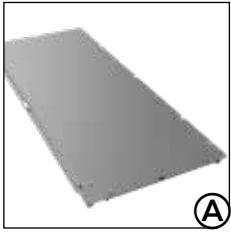

## KLEINTEILEPAKET

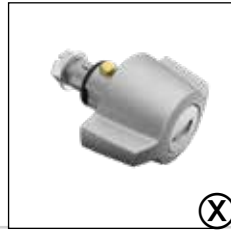
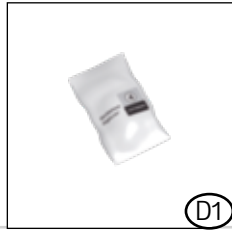
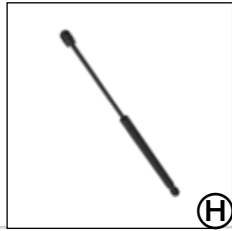

## 2 CORPUS PACKAGE

Corpus · Colis de l'ossature

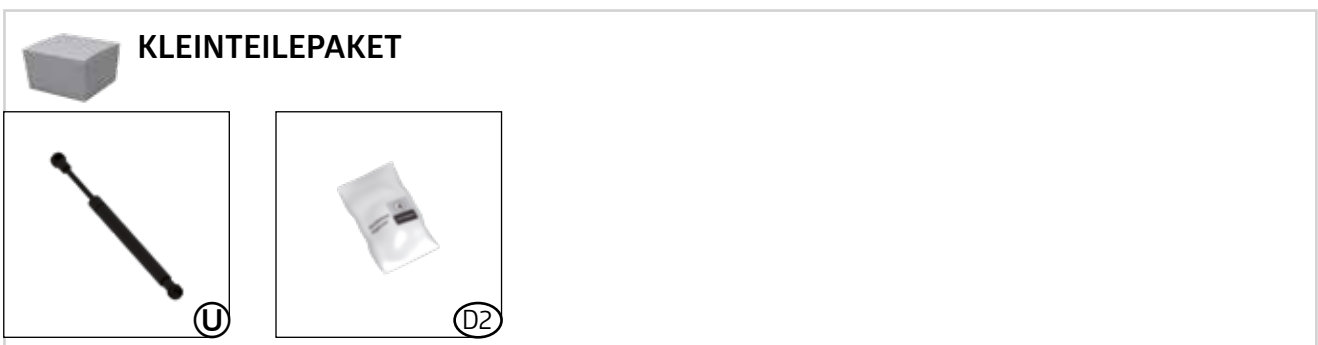
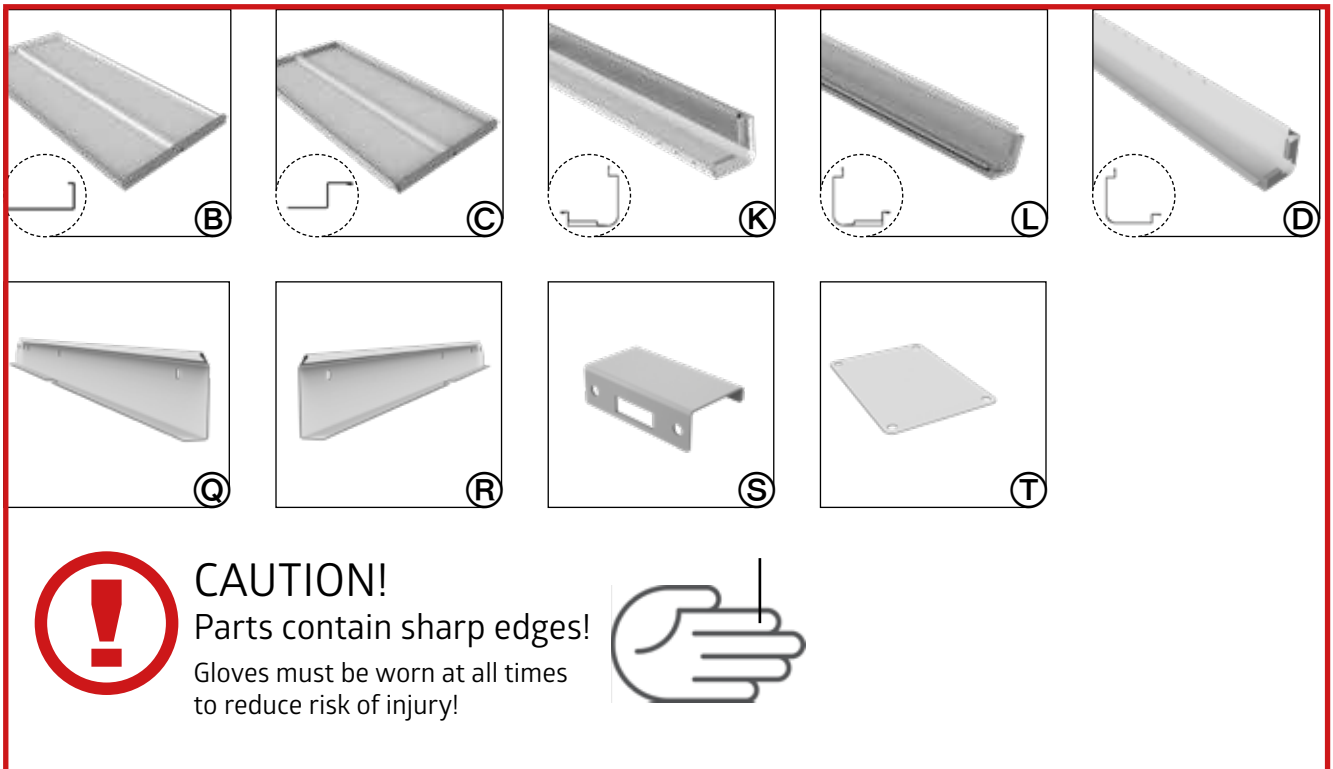





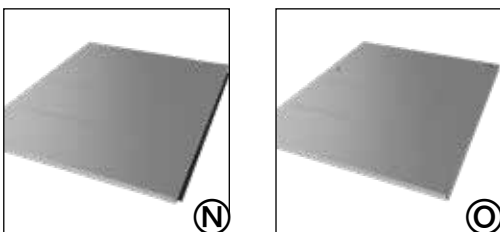

## 3 DOOR PACKAGE

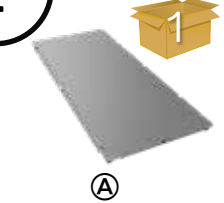
Kit de puerta · Carton de portes



1.

	1x		1x		2x
M6 x 12 	4x		2x		2x
M4 x 18 	2x				

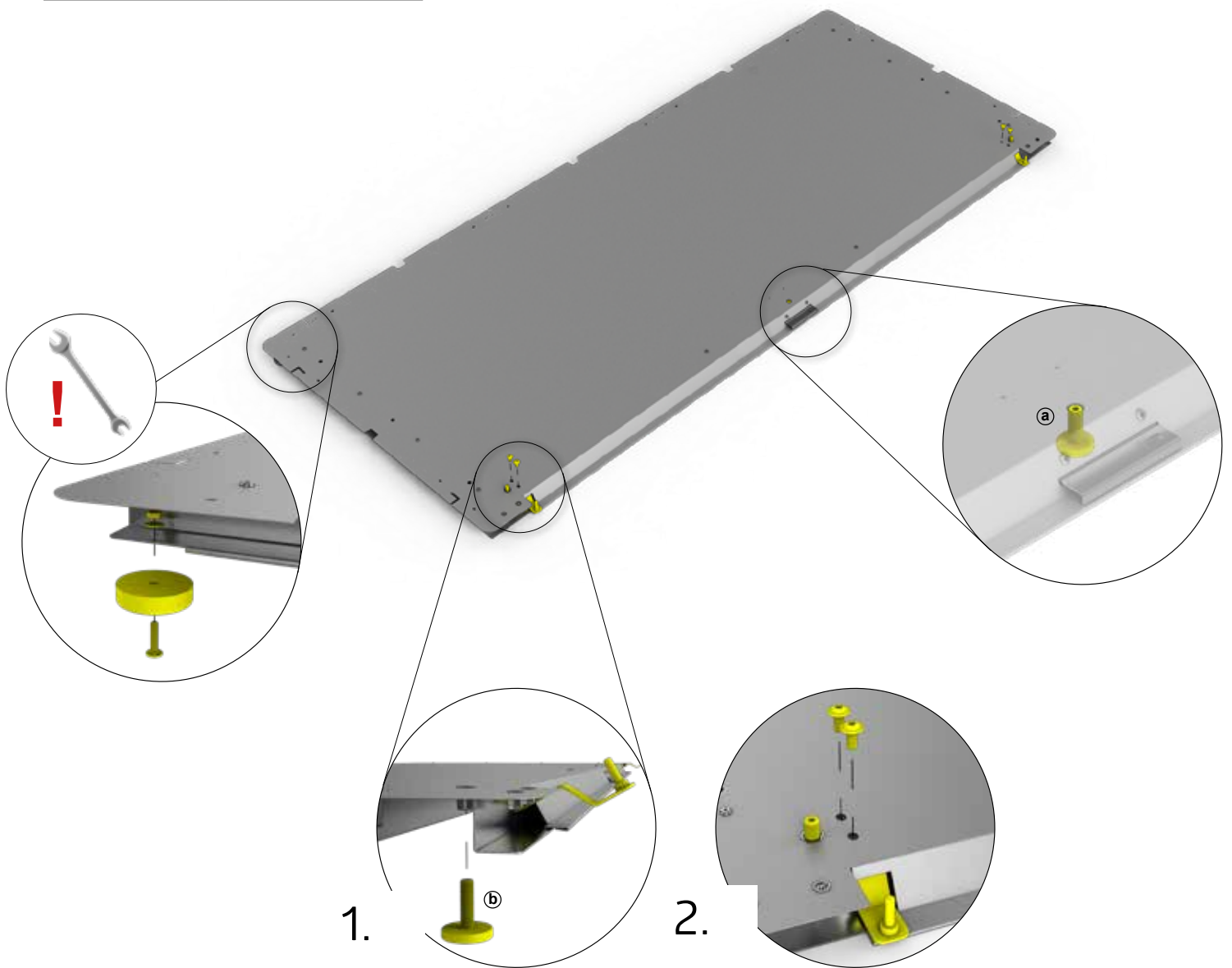

**IMPORTANT: SHARP EDGES! USE WORK GLOVES TO PREVENT INJURY!**

(ES) Importante: ¡Cantos afilados! Utilice guantes de trabajo para evitar lesiones.

(FR) Important : bords tranchants ! Utilisez des gants de travail pour éviter toute blessure !

<p>2.</p>  <p>Ⓛ</p>	<p>2</p> <p>1x</p>	<p>4,2 x 13</p>  <p>1</p> <p>Ⓛ1</p>	<p>1x</p>	<p>M6 x 12</p>  <p>2</p> <p>Ⓛ2</p>	<p>2x</p>
---	--------------------	--	-----------	---	-----------

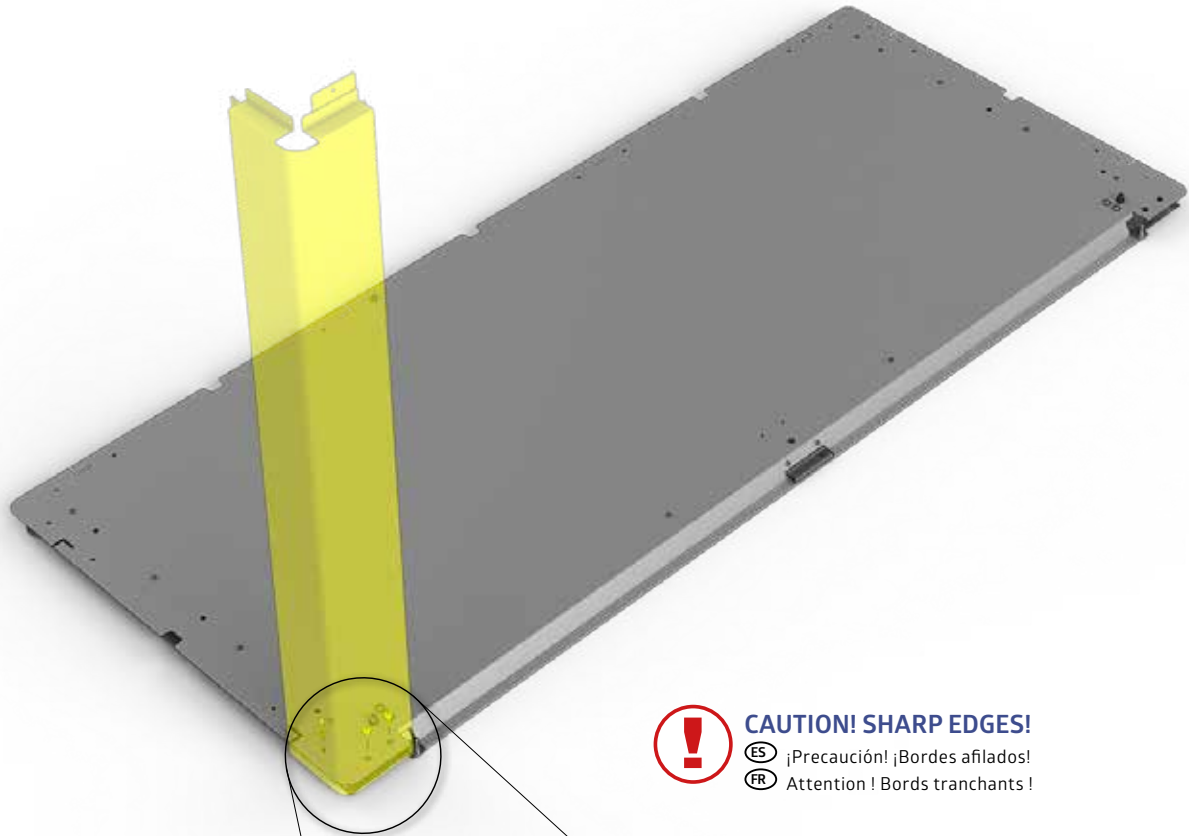

**CAUTION! SHARP EDGES!**  
 ⓁES ¡Precaución! ¡Bordes afilados!  
 ⓁFR Attention ! Bords tranchants !

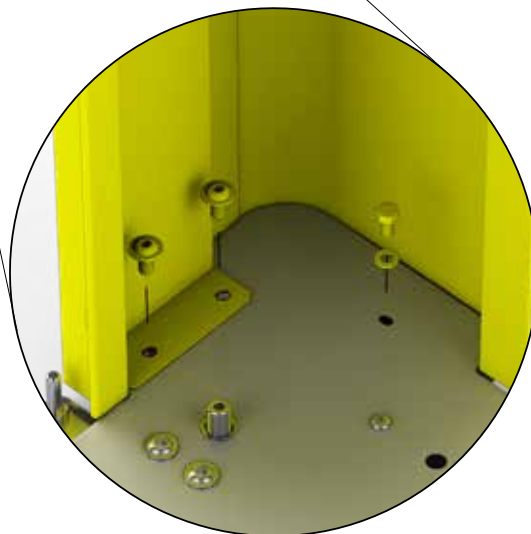



**IMPORTANT: SHARP EDGES! USE WORK GLOVES TO PREVENT INJURY!**

ⓁES Importante: ¡Cantos afilados! Utilice guantes de trabajo para evitar lesiones.

ⓁFR Important : bords tranchants ! Utilisez des gants de travail pour éviter toute blessure !





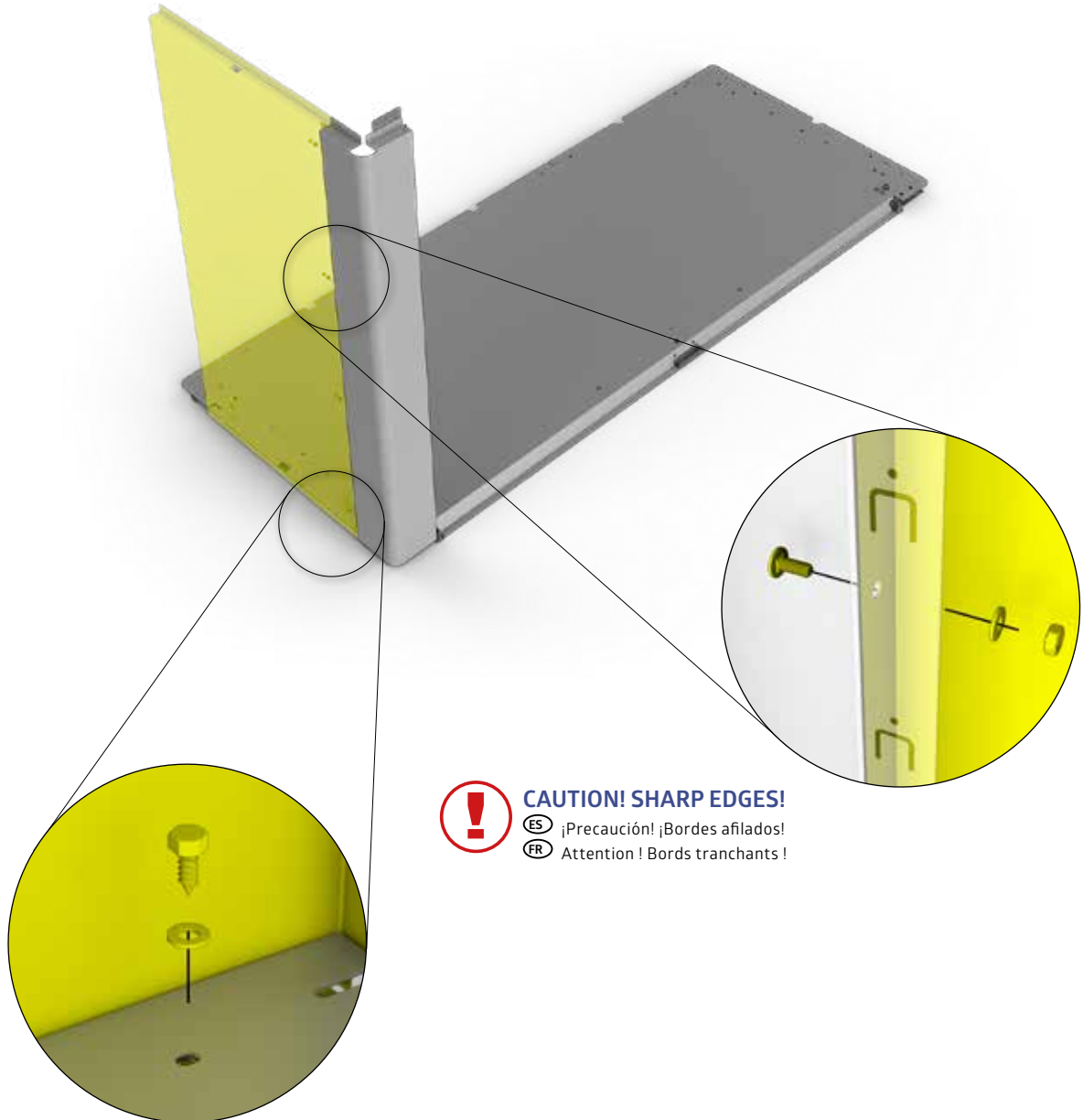



3.	 1x	4,2 x 13  (D1)	2x	M4 x 10  (D1)	4x
----	--	---	----	--	----





**CAUTION! SHARP EDGES!**  
 (ES) ¡Precaución! ¡Bordes afilados!  
 (FR) Attention ! Bords tranchants !



**IMPORTANT: SHARP EDGES! USE WORK GLOVES TO PREVENT INJURY!**  
 (ES) Importante: ¡Cantos afilados! Utilice guantes de trabajo para evitar lesiones.  
 (FR) Important : bords tranchants ! Utilisez des gants de travail pour éviter toute blessure !

4.	  1x	4,2 x 13   1x	2x	M4 x 10   1x	4x
----	---	--	----	---	----



**CAUTION! SHARP EDGES!**

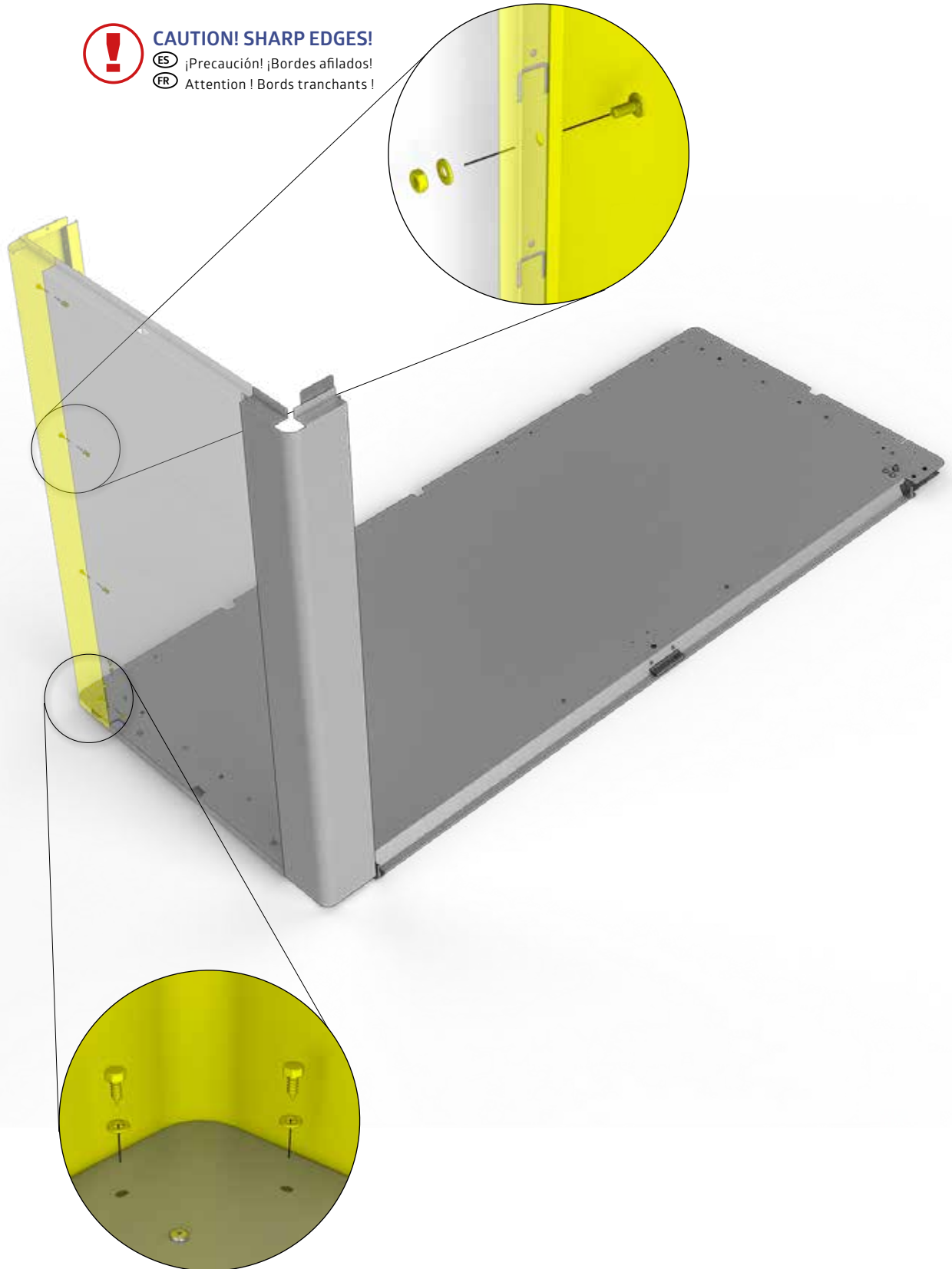





 ¡Precaución! ¡Bordes afilados!  
 Attention ! Bords tranchants !



**! IMPORTANT: SHARP EDGES! USE WORK GLOVES TO PREVENT INJURY!**





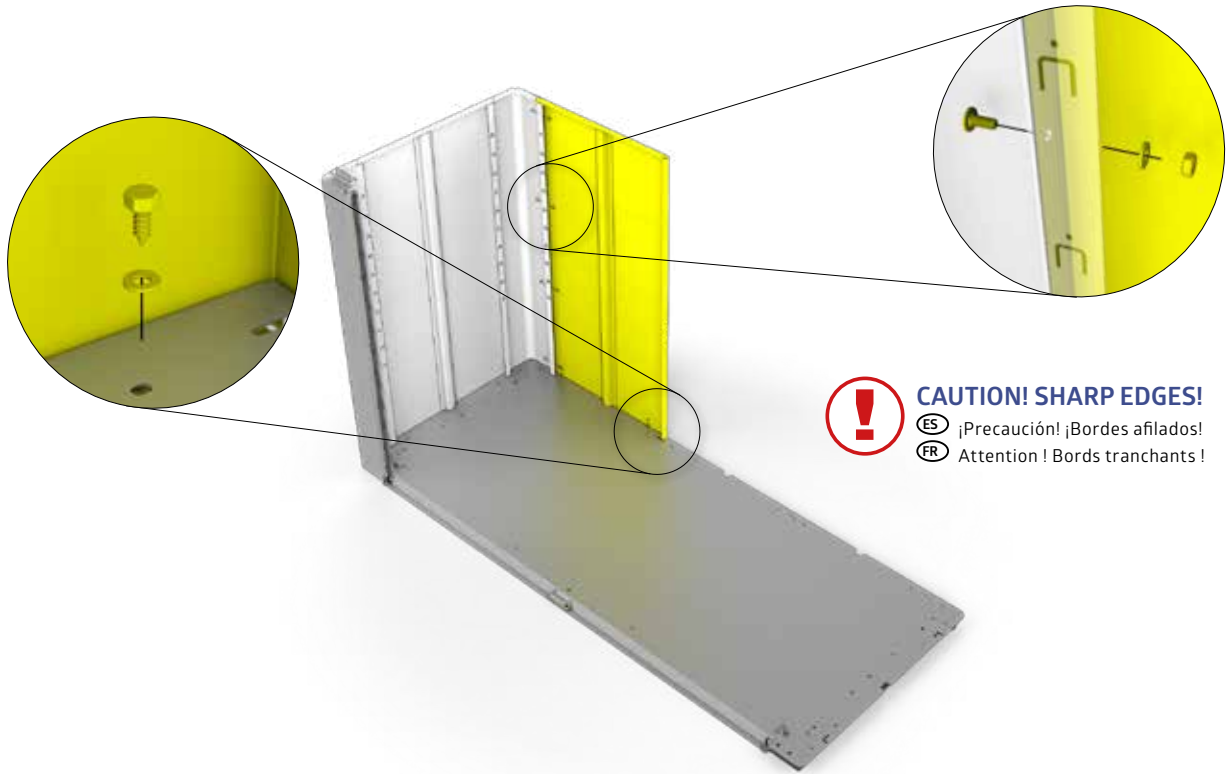

 Importante: ¡Cantos afilados! Utilice guantes de trabajo para evitar lesiones.

 Important : bords tranchants ! Utilisez des gants de travail pour éviter toute blessure !

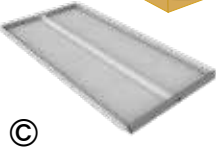
5.	 	1x	 	2x	 	4x
	Ⓑ		4,2 x 13 Ⓓ1		M4 x 10 Ⓓ1	



 **CAUTION! SHARP EDGES!**  
 ⒺS ¡Precaución! ¡Bordes afilados!  
 ⒺFR Attention ! Bords tranchants !

6.	 	1x	 	2x	 	4x
	Ⓒ		4,2 x 13 Ⓓ1		M4 x 10 Ⓓ1	

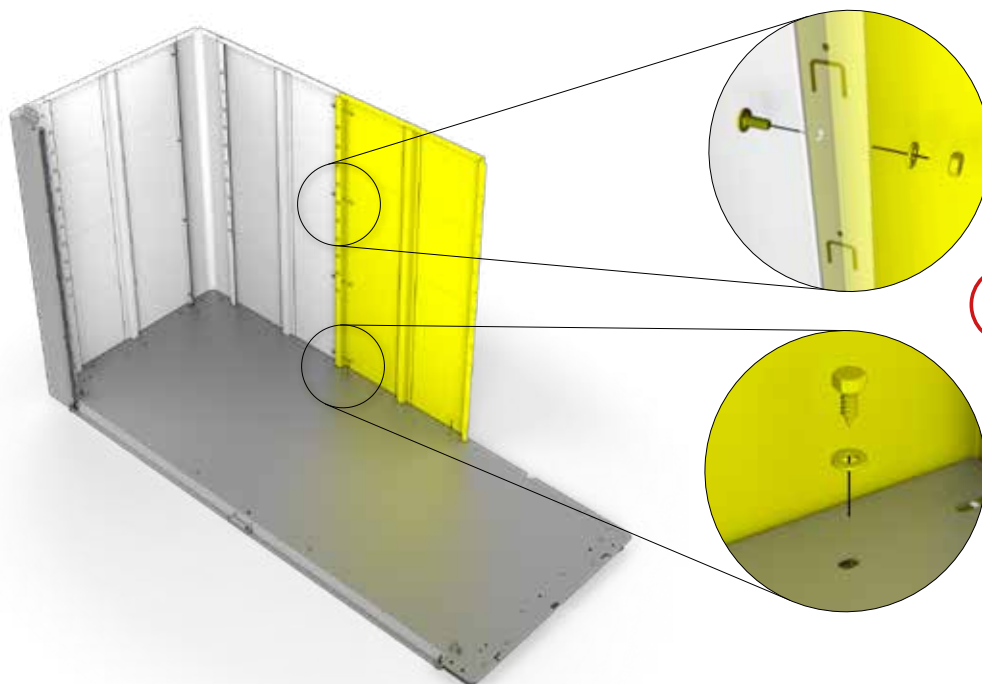

 **CAUTION! SHARP EDGES!**  
 ⒺS ¡Precaución! ¡Bordes afilados!  
 ⒺFR Attention ! Bords tranchants !

 **IMPORTANT: SHARP EDGES! USE WORK GLOVES TO PREVENT INJURY!**



ⒺS Importante: ¡Cantos afilados! Utilice guantes de trabajo para evitar lesiones.

ⒺFR Important : bords tranchants ! Utilisez des gants de travail pour éviter toute blessure !

7.	  	1x	 4,2 x 13 	1x	 M6 x 12  	2x
----	--	----	--	----	--	----



**CAUTION! SHARP EDGES!**

 ¡Precaución! ¡Bordes afilados!  
 Attention ! Bords tranchants !

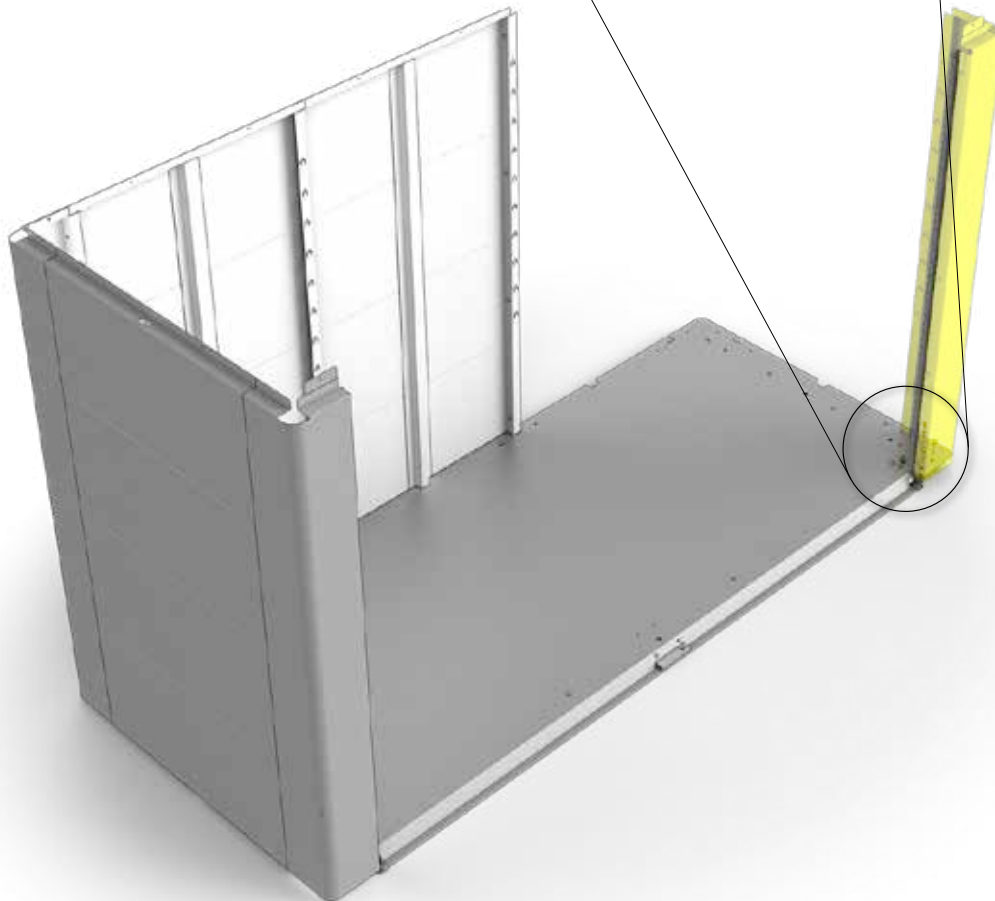

**IMPORTANT: SHARP EDGES! USE WORK GLOVES TO PREVENT INJURY!**

 Importante: ¡Cantos afilados! Utilice guantes de trabajo para evitar lesiones.

 Important : bords tranchants ! Utilisez des gants de travail pour éviter toute blessure !

8.	 1x	 4,2 x 13 D1	2x	 M4 x 10 D1	4x
----	--	--	----	---	----

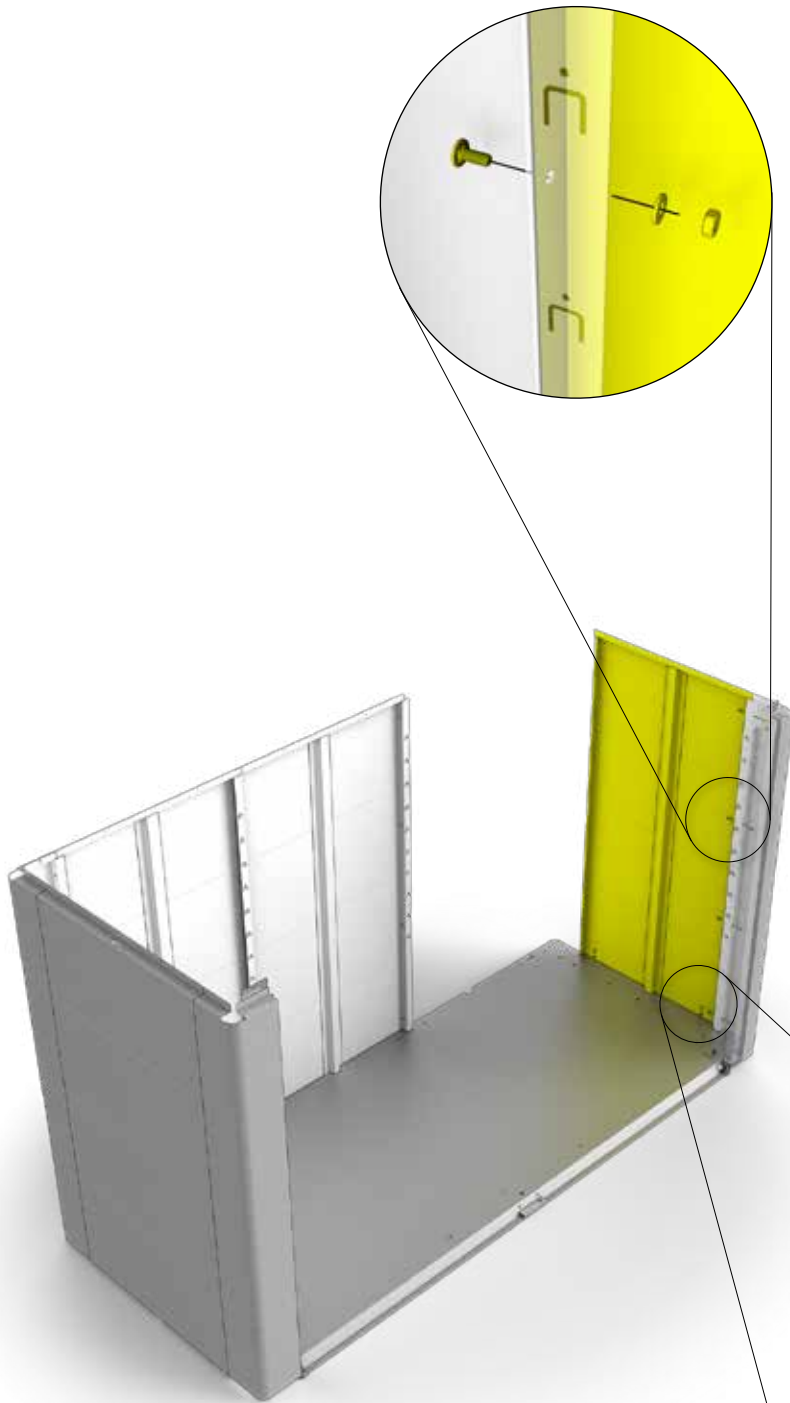

**CAUTION! SHARP EDGES!**

ES ¡Precaución! ¡Bordes afilados!







FR Attention ! Bords tranchants !



**IMPORTANT: SHARP EDGES! USE WORK GLOVES TO PREVENT INJURY!**



ES Importante: ¡Cantos afilados! Utilice guantes de trabajo para evitar lesiones.

FR Important : bords tranchants ! Utilisez des gants de travail pour éviter toute blessure !

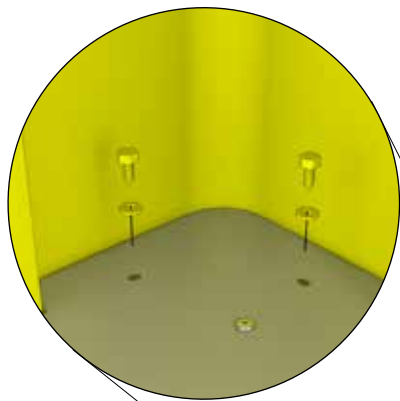
9.	  1x	4,2 x 13   2x	M4 x 10   4x
----	--	--	---



**CAUTION! SHARP EDGES!**

 ¡Precaución! ¡Bordes afilados!  
 Attention ! Bords tranchants !

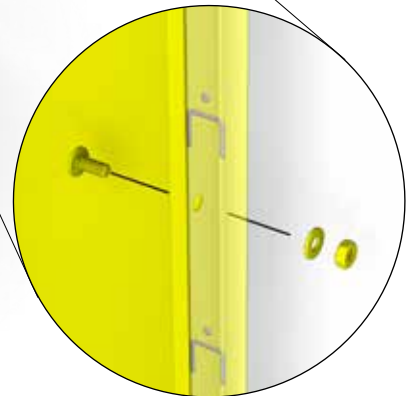
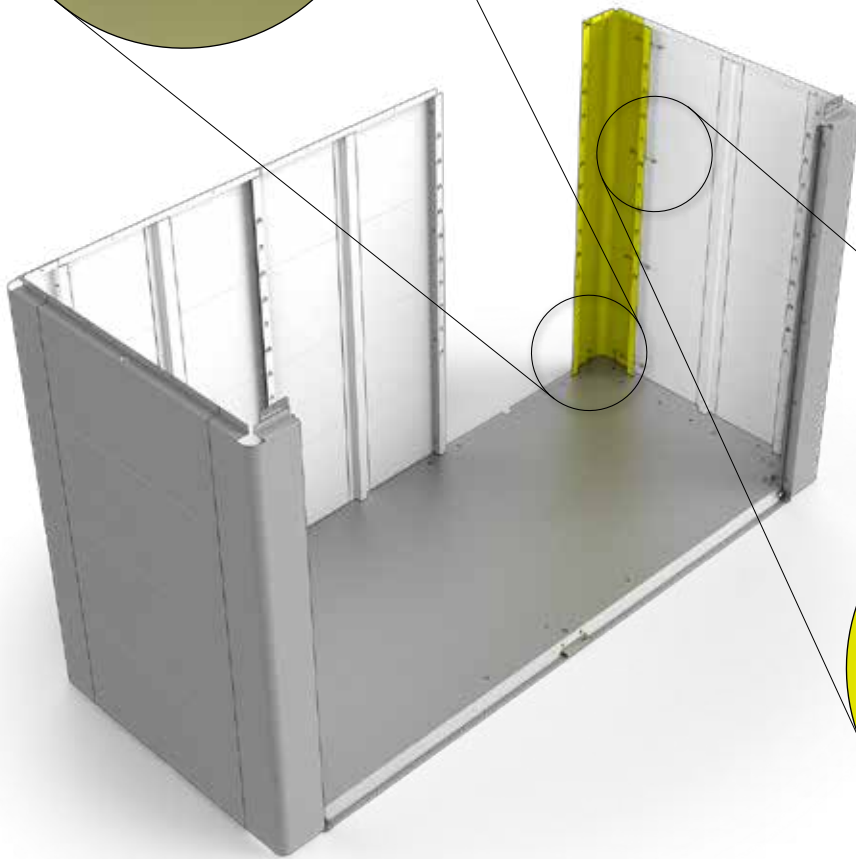



 **IMPORTANT: SHARP EDGES! USE WORK GLOVES TO PREVENT INJURY!**

 Importante: ¡Cantos afilados! Utilice guantes de trabajo para evitar lesiones.

 Important : bords tranchants ! Utilisez des gants de travail pour éviter toute blessure !

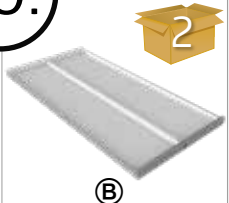
10.

 Ⓟ	1x	 4,2 x 13 Ⓛ1	2x	 M4 x 10 Ⓛ1	8x
---	----	---	----	--	----

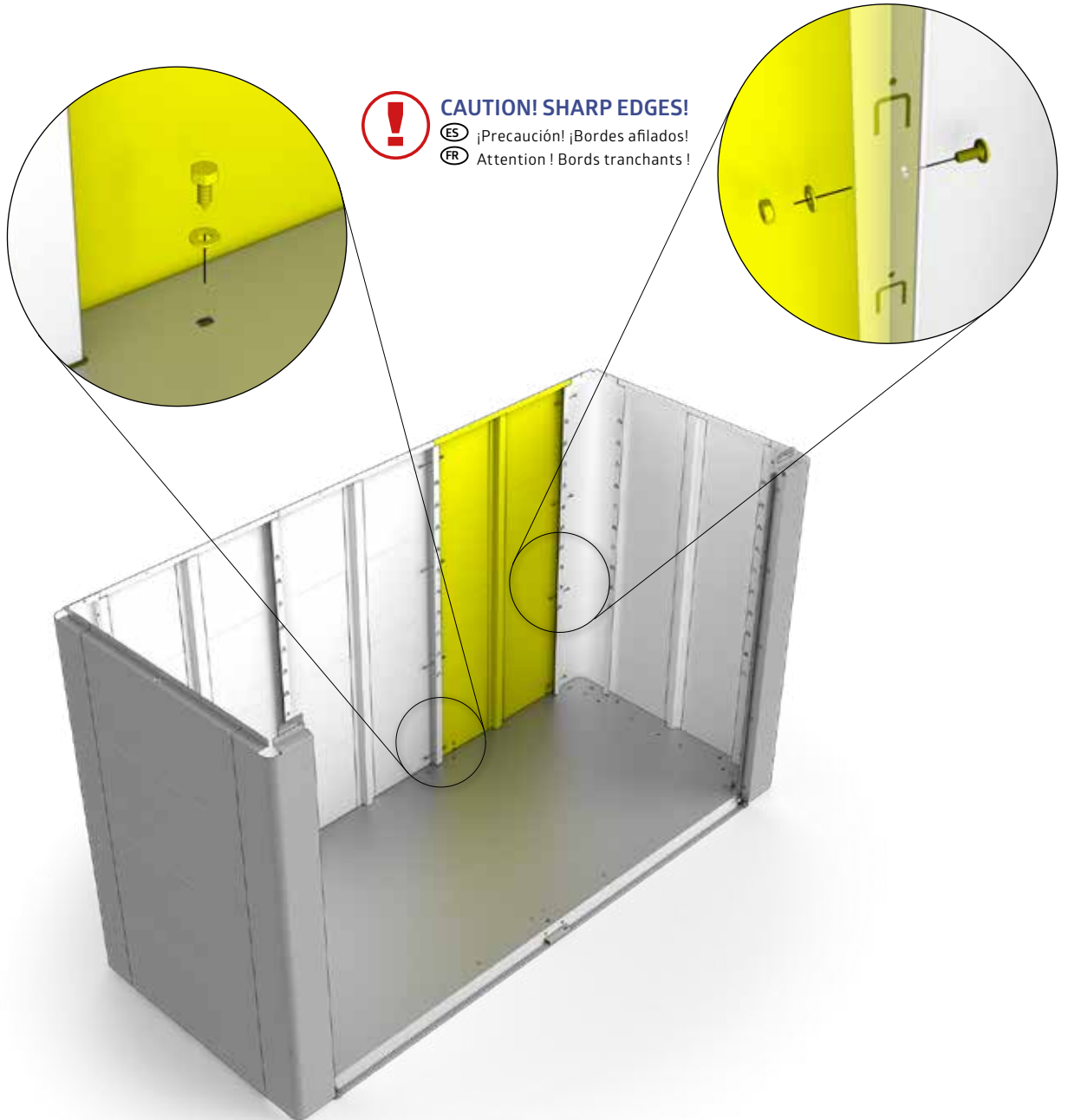

**IMPORTANT: SHARP EDGES! USE WORK GLOVES TO PREVENT INJURY!**

Ⓟ Importante: ¡Cantos afilados! Utilice guantes de trabajo para evitar lesiones.

Ⓛ1 Important : bords tranchants ! Utilisez des gants de travail pour éviter toute blessure !

11.	 	1x	M4 x 10    	2x	 	2x
-----	--	----	--	----	---	----

1.

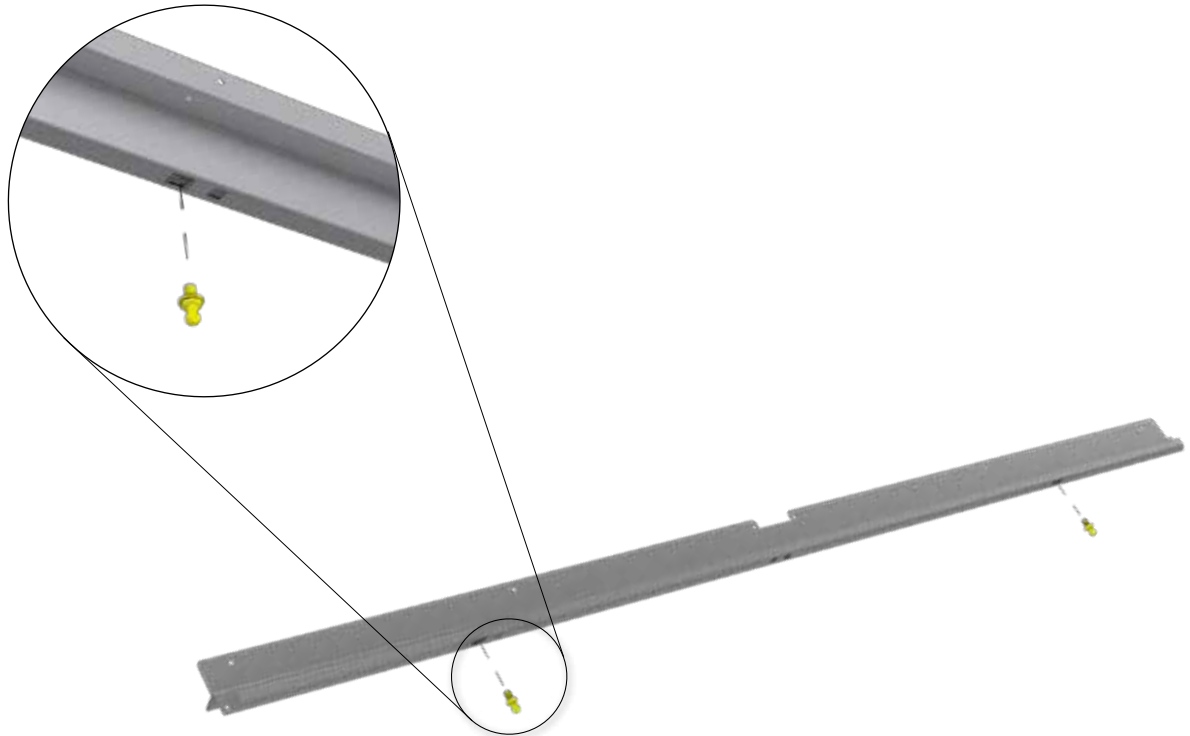

2.

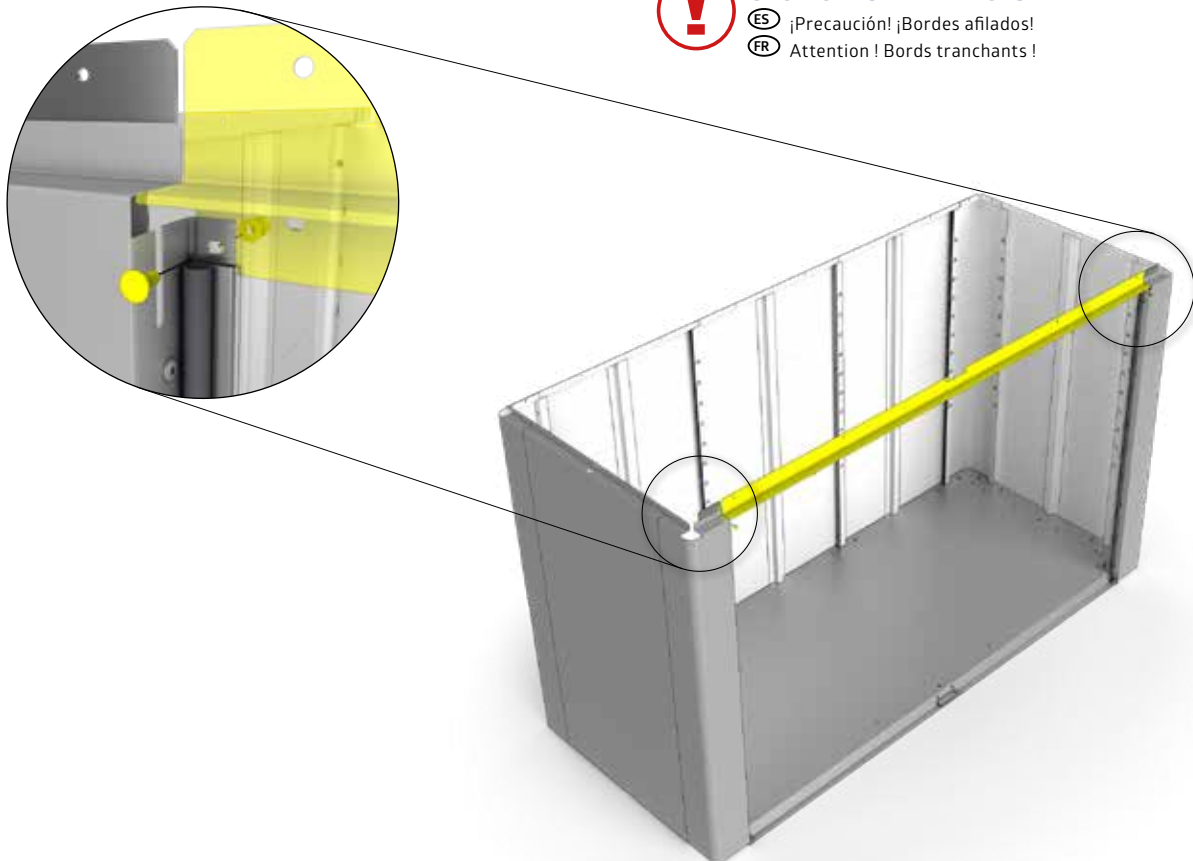

**CAUTION! SHARP EDGES!**

ES ¡Precaución! ¡Bordes afilados!  
FR Attention ! Bords tranchants !

 **IMPORTANT: SHARP EDGES! USE WORK GLOVES TO PREVENT INJURY!**

ES Importante: ¡Cantos afilados! Utilice guantes de trabajo para evitar lesiones.

FR Important : bords tranchants ! Utilisez des gants de travail pour éviter toute blessure !



12.

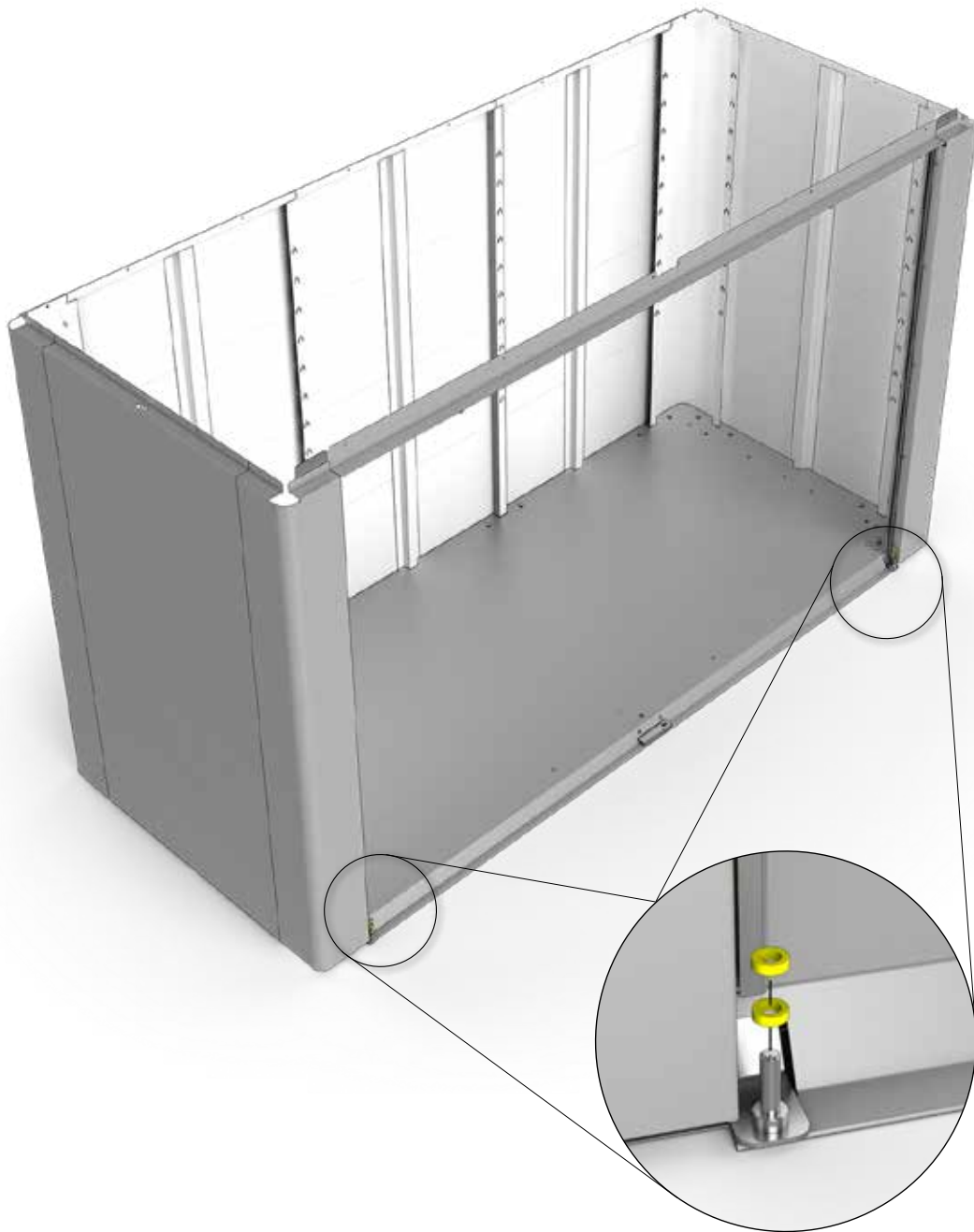
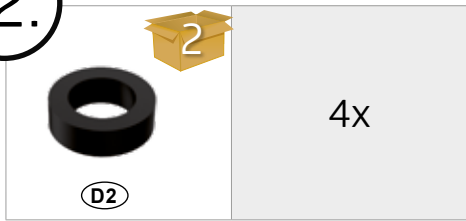





**IMPORTANT: SHARP EDGES! USE WORK GLOVES TO PREVENT INJURY!**

Ⓔ **ES** Importante: ¡Cantos afilados! Utilice guantes de trabajo para evitar lesiones.

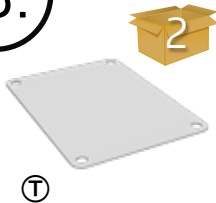
Ⓔ **FR** Important : bords tranchants ! Utilisez des gants de travail pour éviter toute blessure !

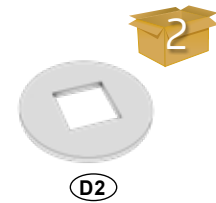
13.

	1x	3,9 x 13 	4x		1x
	1x				

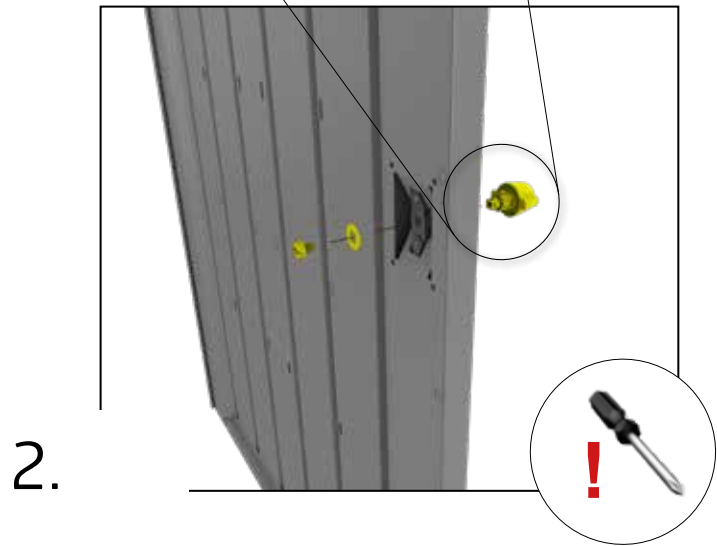
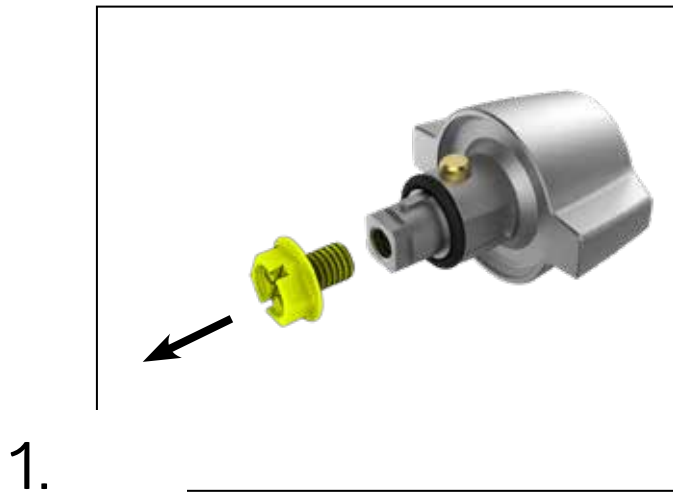
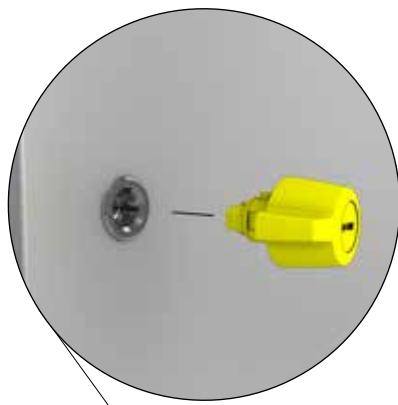







 **IMPORTANT: SHARP EDGES! USE WORK GLOVES TO PREVENT INJURY!**

 Importante: ¡Cantos afilados! Utilice guantes de trabajo para evitar lesiones.

 Important : bords tranchants ! Utilisez des gants de travail pour éviter toute blessure !

14.

 (D2)	2x	 (D2)	1x	 (D2)	1x
 (N)	1x	 (S)	2x	 (D2)	2x
M6 x 12  (D2)	8x				

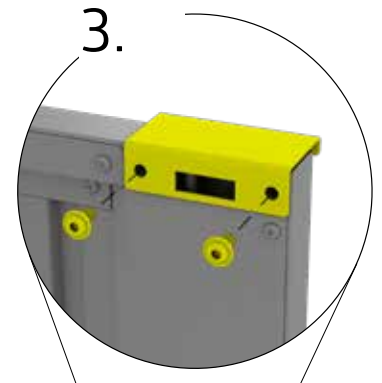
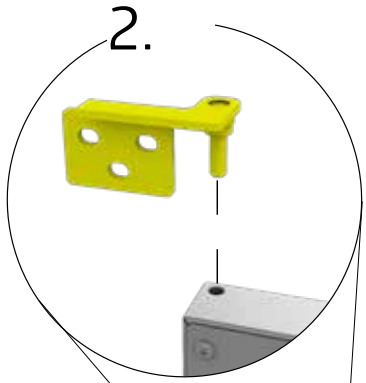
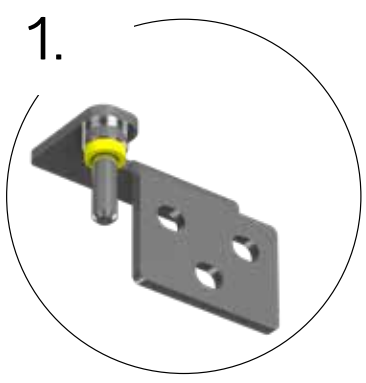

2x

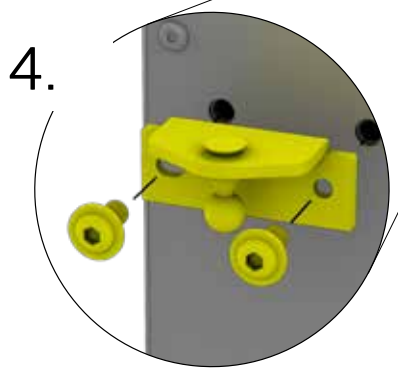

**IMPORTANT: SHARP EDGES! USE WORK GLOVES TO PREVENT INJURY!**

(ES) Importante: ¡Cantos afilados! Utilice guantes de trabajo para evitar lesiones.

(FR) Important : bords tranchants ! Utilisez des gants de travail pour éviter toute blessure !

15.

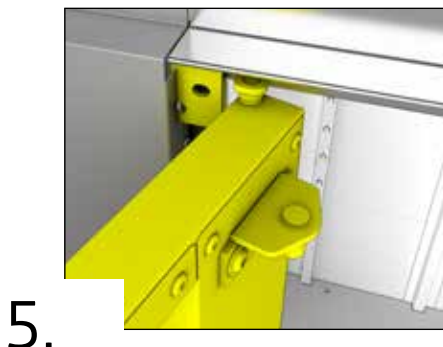
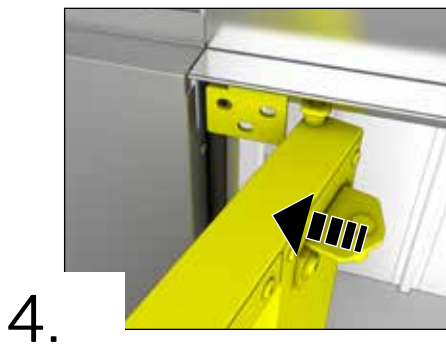
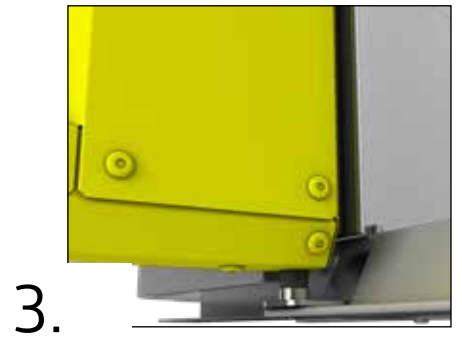
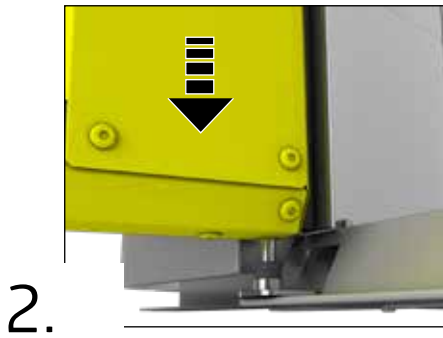
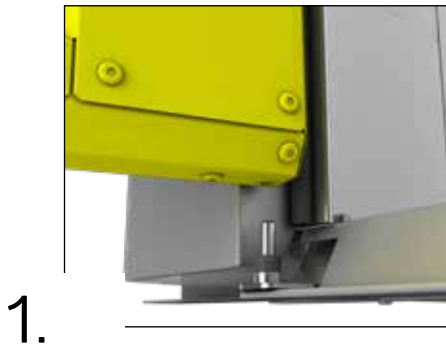
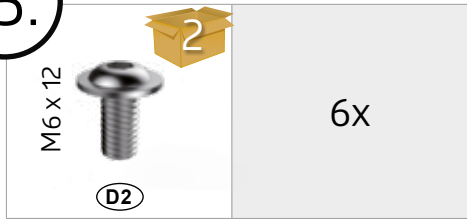

**! IMPORTANT: SHARP EDGES! USE WORK GLOVES TO PREVENT INJURY!**

**(ES)** Importante: ¡Cantos afilados! Utilice guantes de trabajo para evitar lesiones.

**(FR)** Important : bords tranchants ! Utilisez des gants de travail pour éviter toute blessure !

16.

	1x	M4 x 10		5x
---	----	---------	---	----

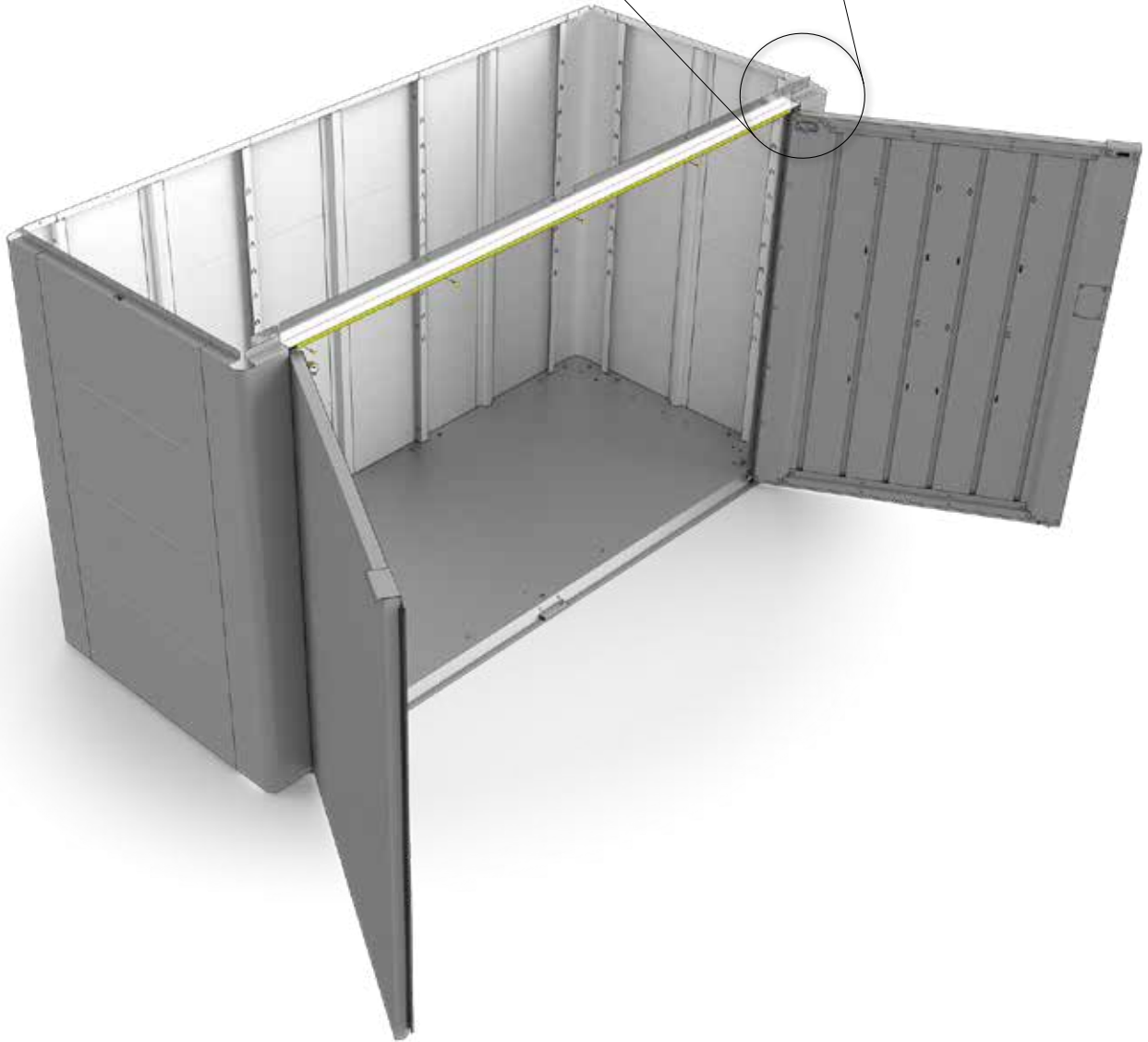
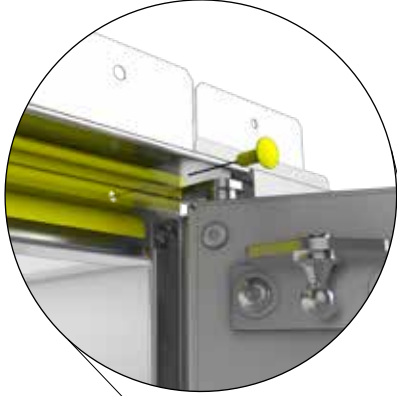

**IMPORTANT: SHARP EDGES! USE WORK GLOVES TO PREVENT INJURY!**

Ⓔ **ES** Importante: ¡Cantos afilados! Utilice guantes de trabajo para evitar lesiones.

Ⓕ **FR** Important : bords tranchants ! Utilisez des gants de travail pour éviter toute blessure !

17.

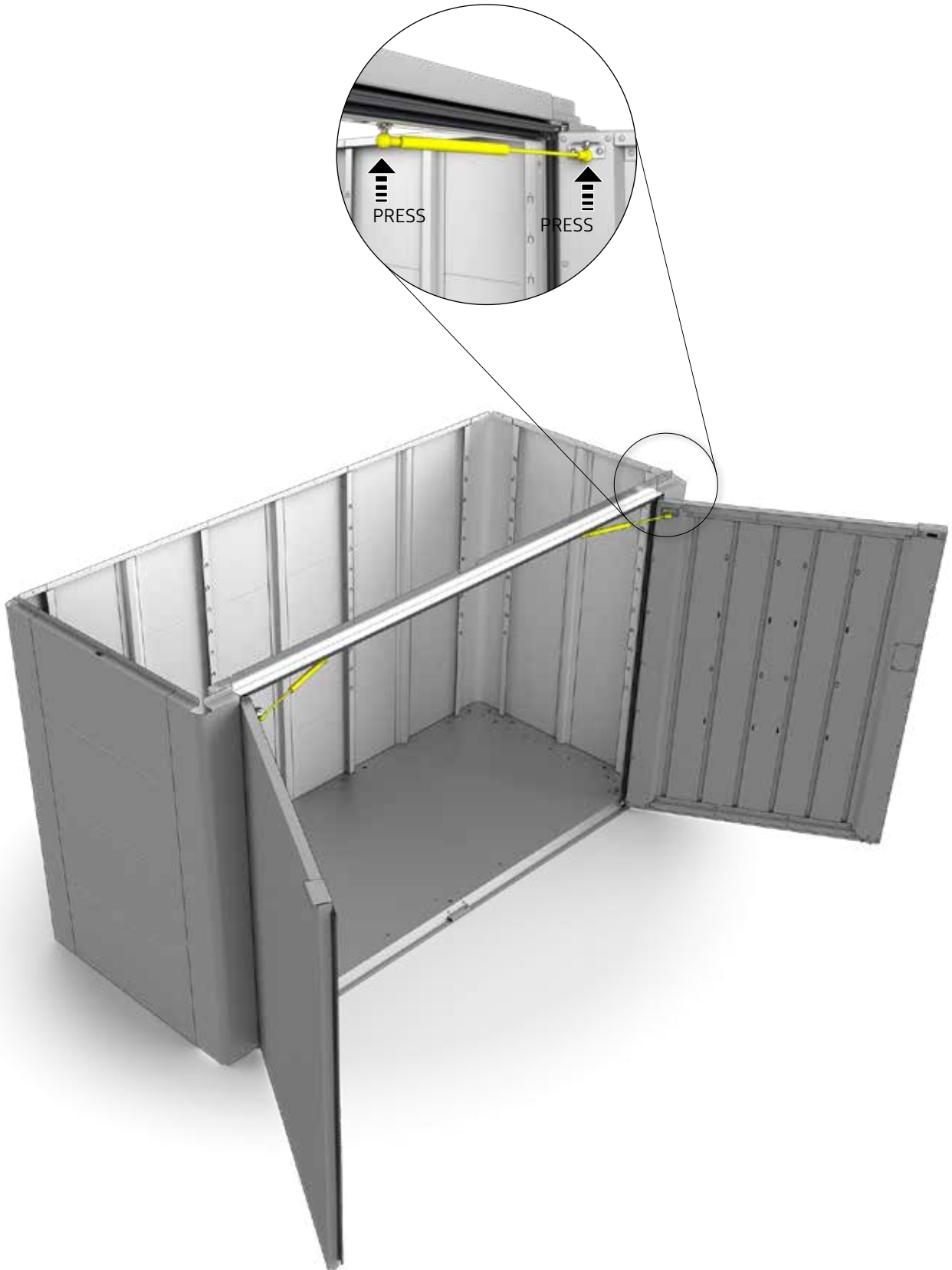
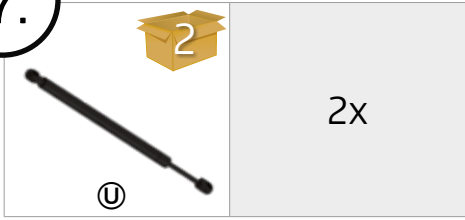

**! IMPORTANT: SHARP EDGES! USE WORK GLOVES TO PREVENT INJURY!**

(ES) Importante: ¡Cantos afilados! Utilice guantes de trabajo para evitar lesiones.

(FR) Important : bords tranchants ! Utilisez des gants de travail pour éviter toute blessure !

18.

 D2	1x	M6 x 12	 D2	2x
---	----	---------	---	----

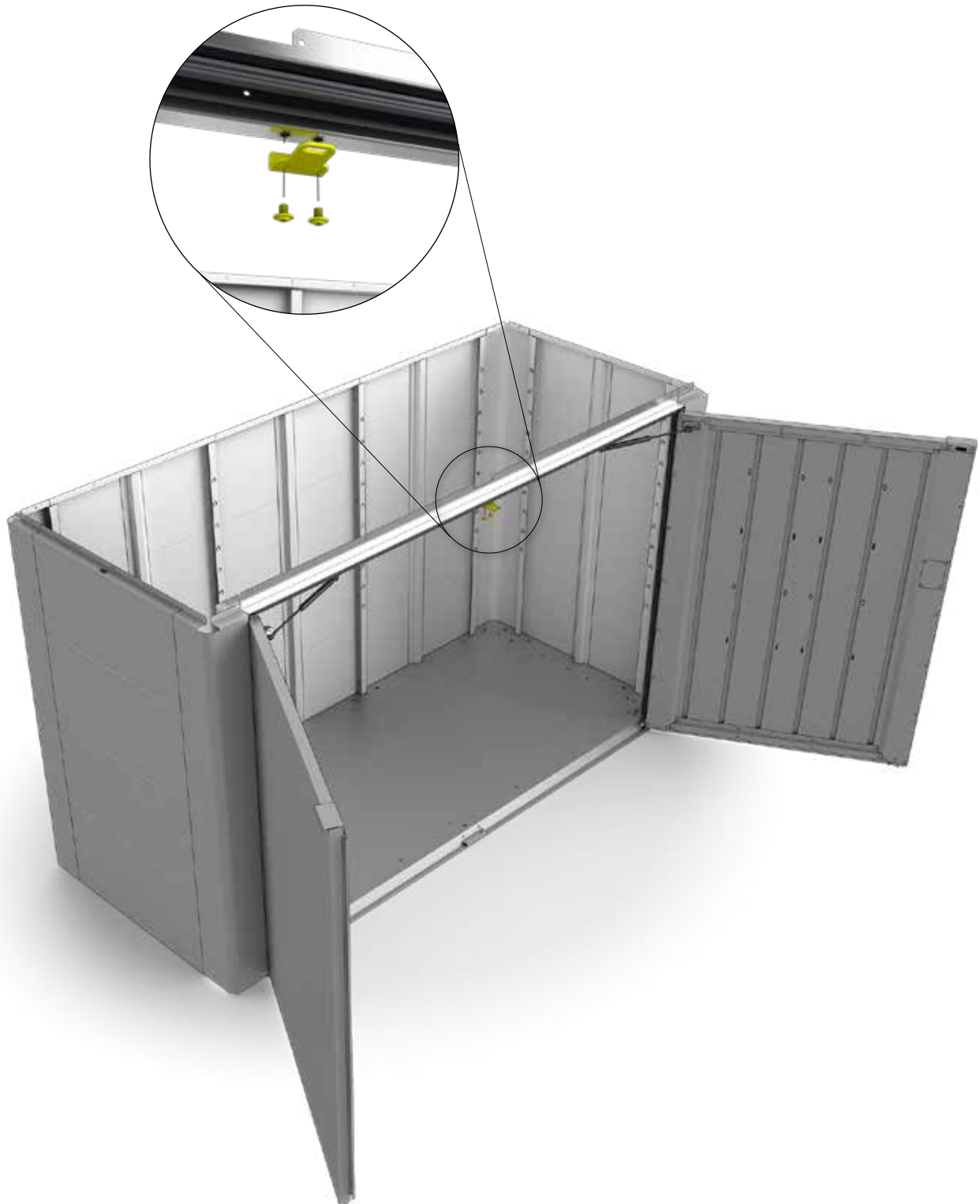



**IMPORTANT: SHARP EDGES! USE WORK GLOVES TO PREVENT INJURY!**

ES Importante: ¡Cantos afilados! Utilice guantes de trabajo para evitar lesiones.

FR Important : bords tranchants ! Utilisez des gants de travail pour éviter toute blessure !

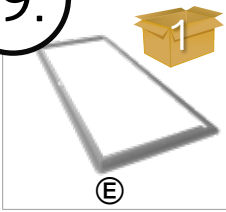
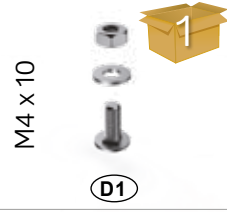
19.

	1x	M4 x 10 	16x		1x
---	----	---	-----	--	----

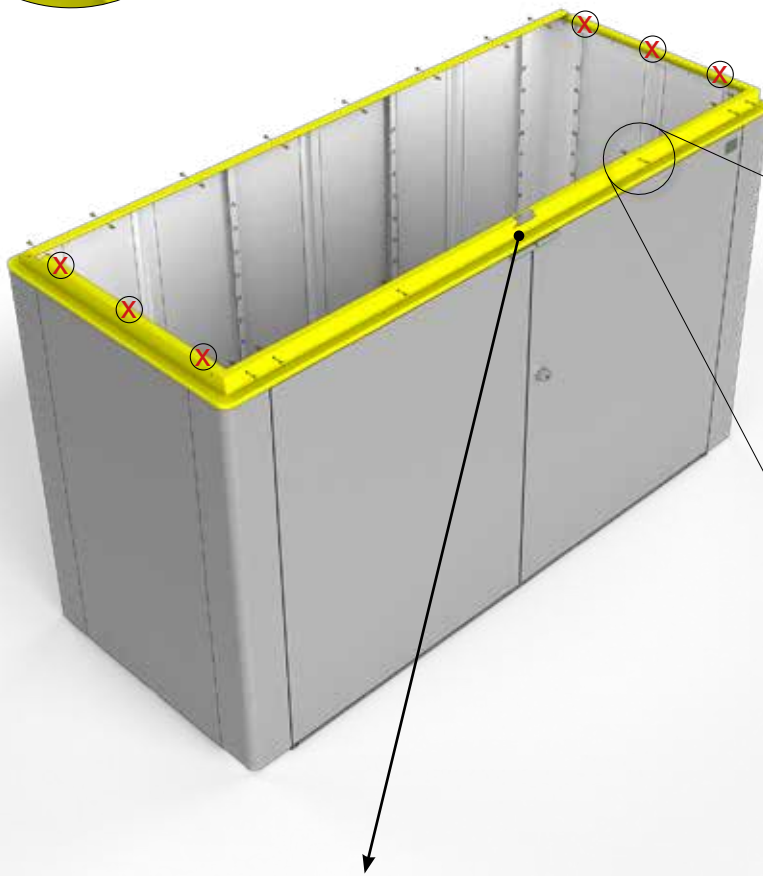
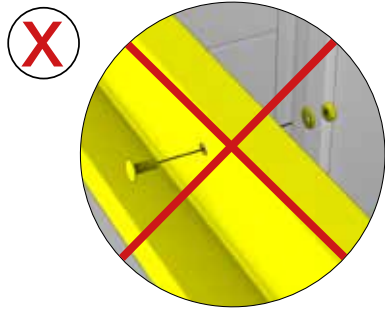

**CAUTION! SHARP EDGES!**  
 (ES) ¡Precaución! ¡Bordes afilados!  
 (FR) Attention ! Bords tranchants !

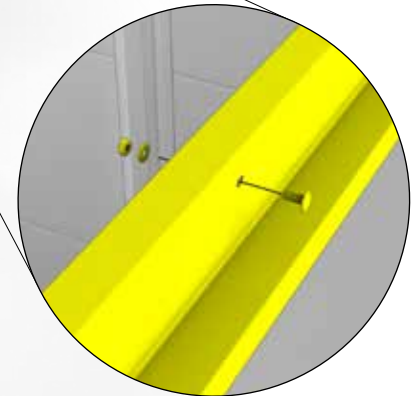

1.

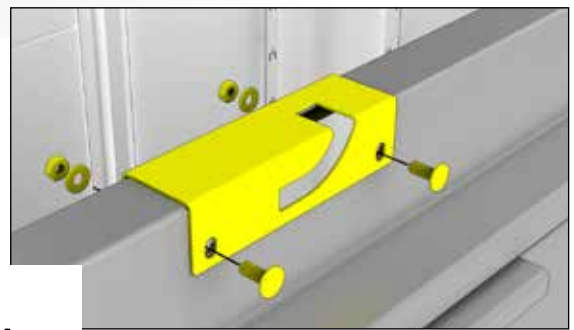

2.

**IMPORTANT: SHARP EDGES! USE WORK GLOVES TO PREVENT INJURY!**

(ES) Importante: ¡Cantos afilados! Utilice guantes de trabajo para evitar lesiones.

(FR) Important : bords tranchants ! Utilisez des gants de travail pour éviter toute blessure !



20.

 Ⓚ	1x	 Ⓡ	1x	M4 x 10  Ⓛ1	4x
 Ⓛ1	5x				

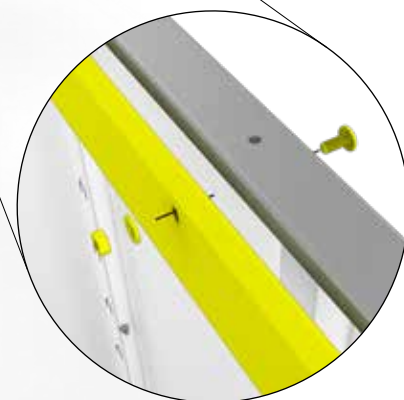
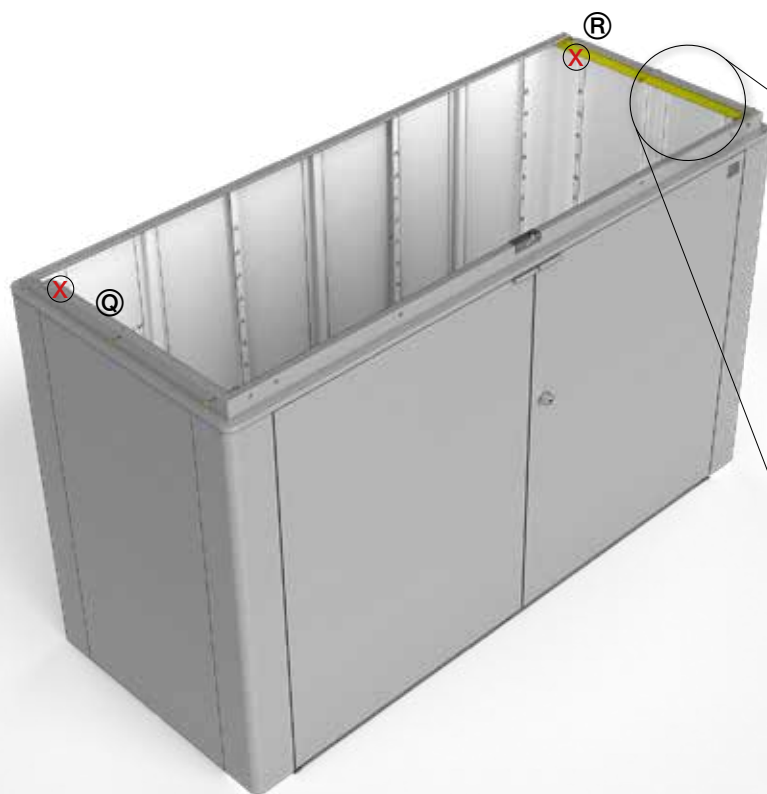
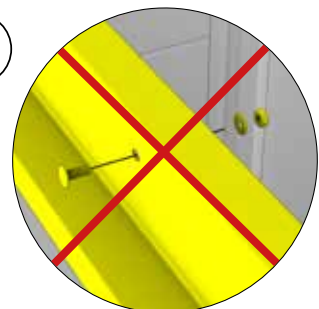

**CAUTION! SHARP EDGES!**

Ⓛ1 ¡Precaución! ¡Bordes afilados!  
Ⓛ2 Attention ! Bords tranchants !



**NOW TIGHTEN ALL NUT AND BOLT CONNECTIONS SECURELY!**

Ahora puede apretar y fijar todos los tornillos y tuercas - Serrez maintenant les vis à fond!







**NOTE: PROTECTIVE CAPS MUST BE INSTALLED TO PREVENT INJURY!**

Ⓛ1 Nota: ¡se deben instalar tapas de protección para evitar lesiones!

Ⓛ2 Remarque : des capuchons de protection doivent être installés pour éviter toute blessure!

21.

 ⓕ	1x	 3,9 x 13 ⓓ2	4x	 Ⓦ	1x
 ⓓ1	1x	 ⓧ	1x		

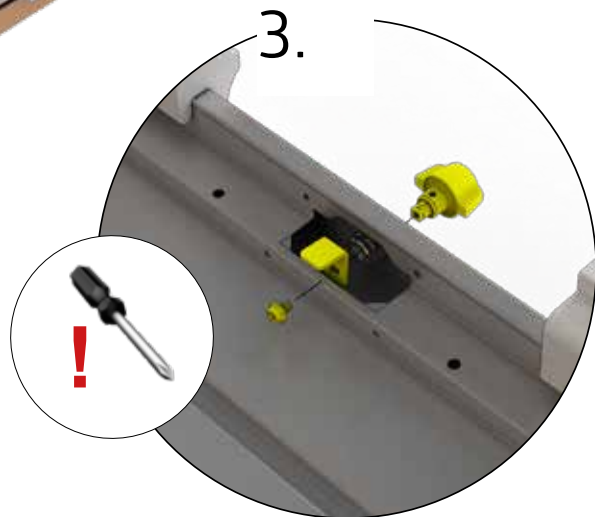
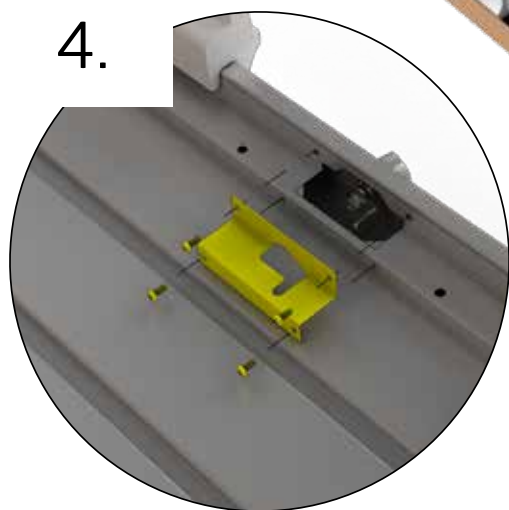
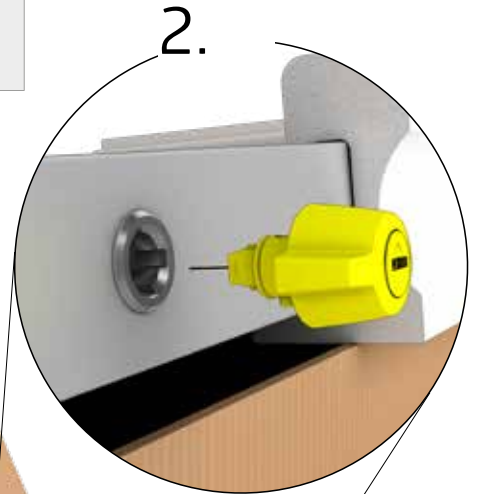
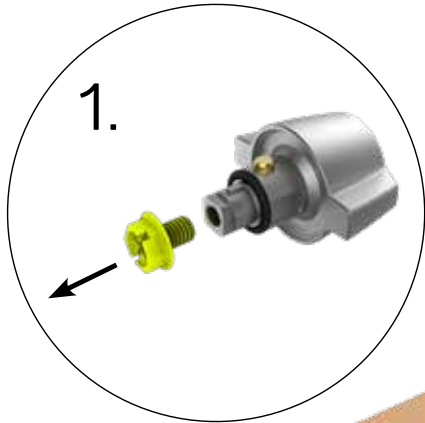

 **IMPORTANT: SHARP EDGES! USE WORK GLOVES TO PREVENT INJURY!**

ⓔS Importante: ¡Cantos afilados! Utilice guantes de trabajo para evitar lesiones.



ⓕR Important : bords tranchants ! Utilisez des gants de travail pour éviter toute blessure !

22.

 1	1x	 1	1x	M6 x 16  1	4x
---	----	---	----	--	----



23.

 1	10x	 1	2x
---	-----	---	----

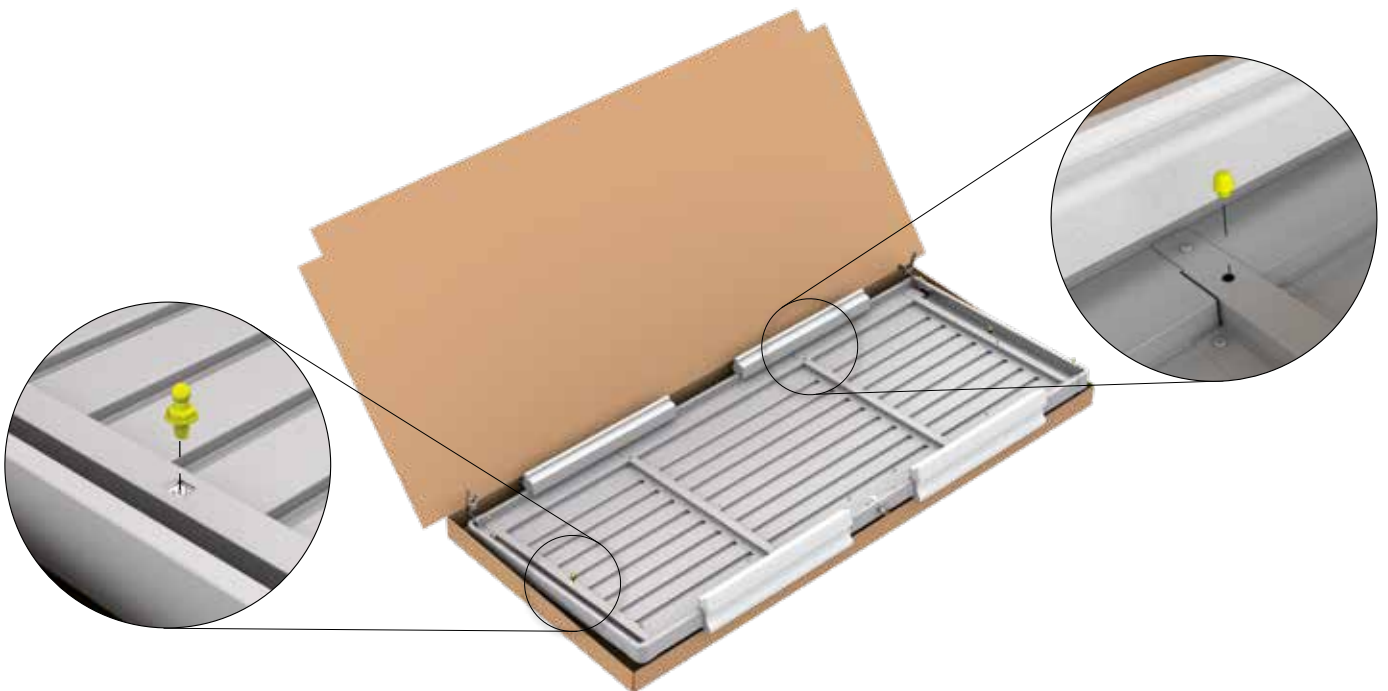

**IMPORTANT: SHARP EDGES! USE WORK GLOVES TO PREVENT INJURY!**

(ES) Importante: ¡Cantos afilados! Utilice guantes de trabajo para evitar lesiones.

(FR) Important : bords tranchants ! Utilisez des gants de travail pour éviter toute blessure !

24.

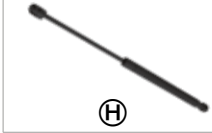

2x

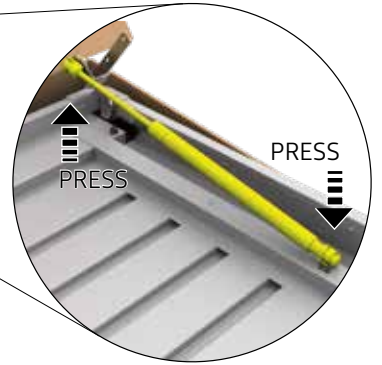
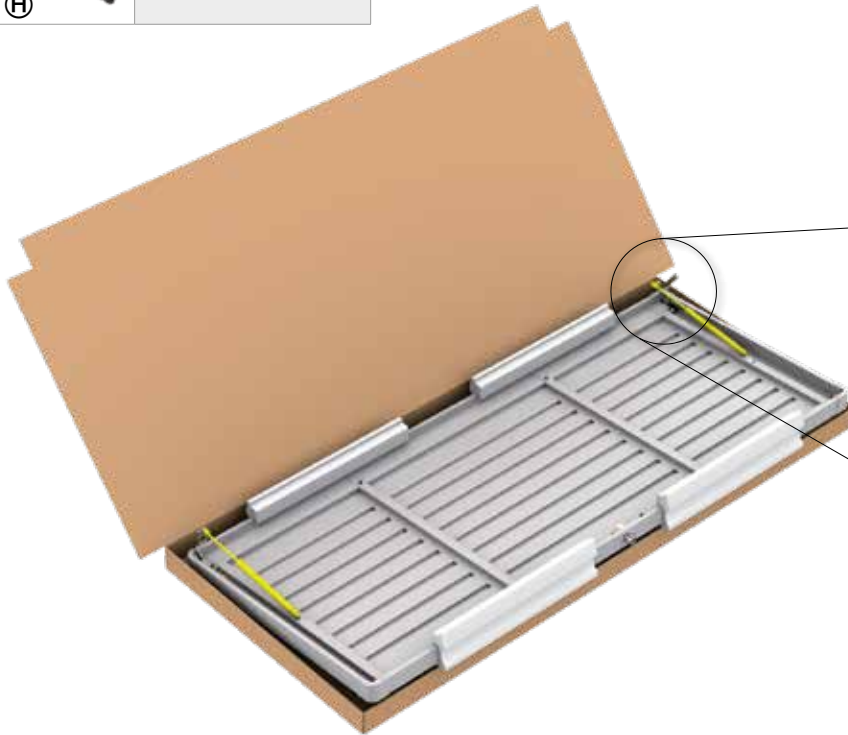

25.



M4 x 18



6x



1x

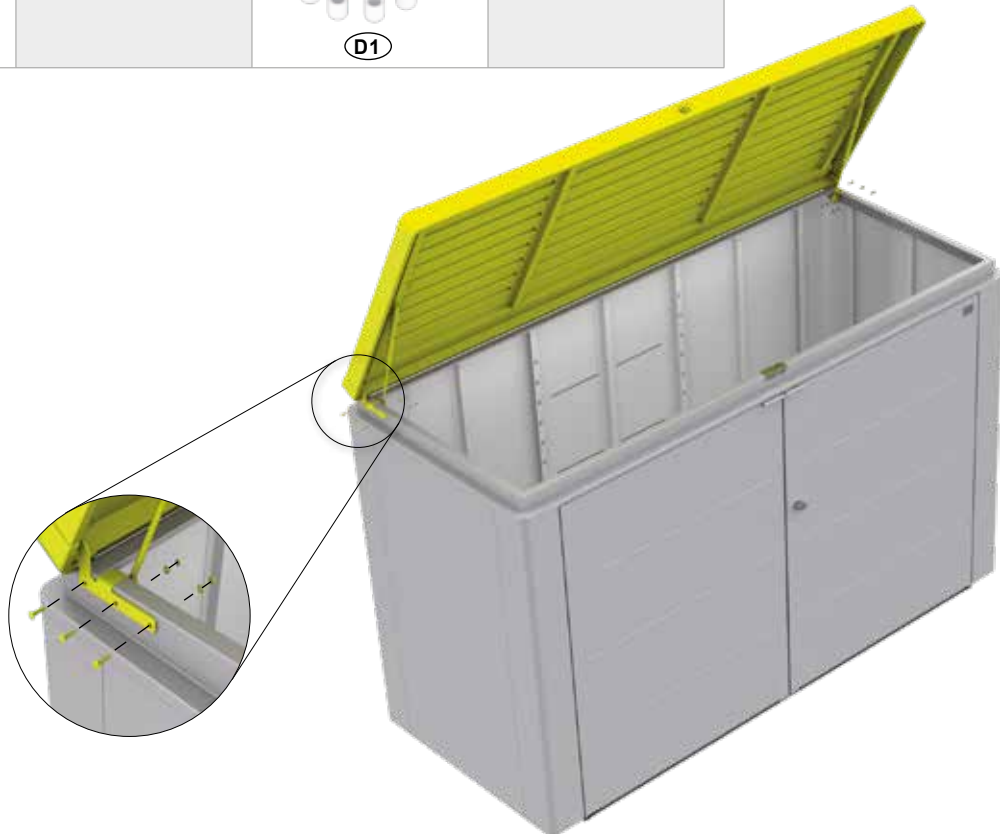

**! IMPORTANT: SHARP EDGES! USE WORK GLOVES TO PREVENT INJURY!**

**(ES)** Importante: ¡Cantos afilados! Utilice guantes de trabajo para evitar lesiones.

**(FR)** Important : bords tranchants ! Utilisez des gants de travail pour éviter toute blessure !

26.



1x

D1

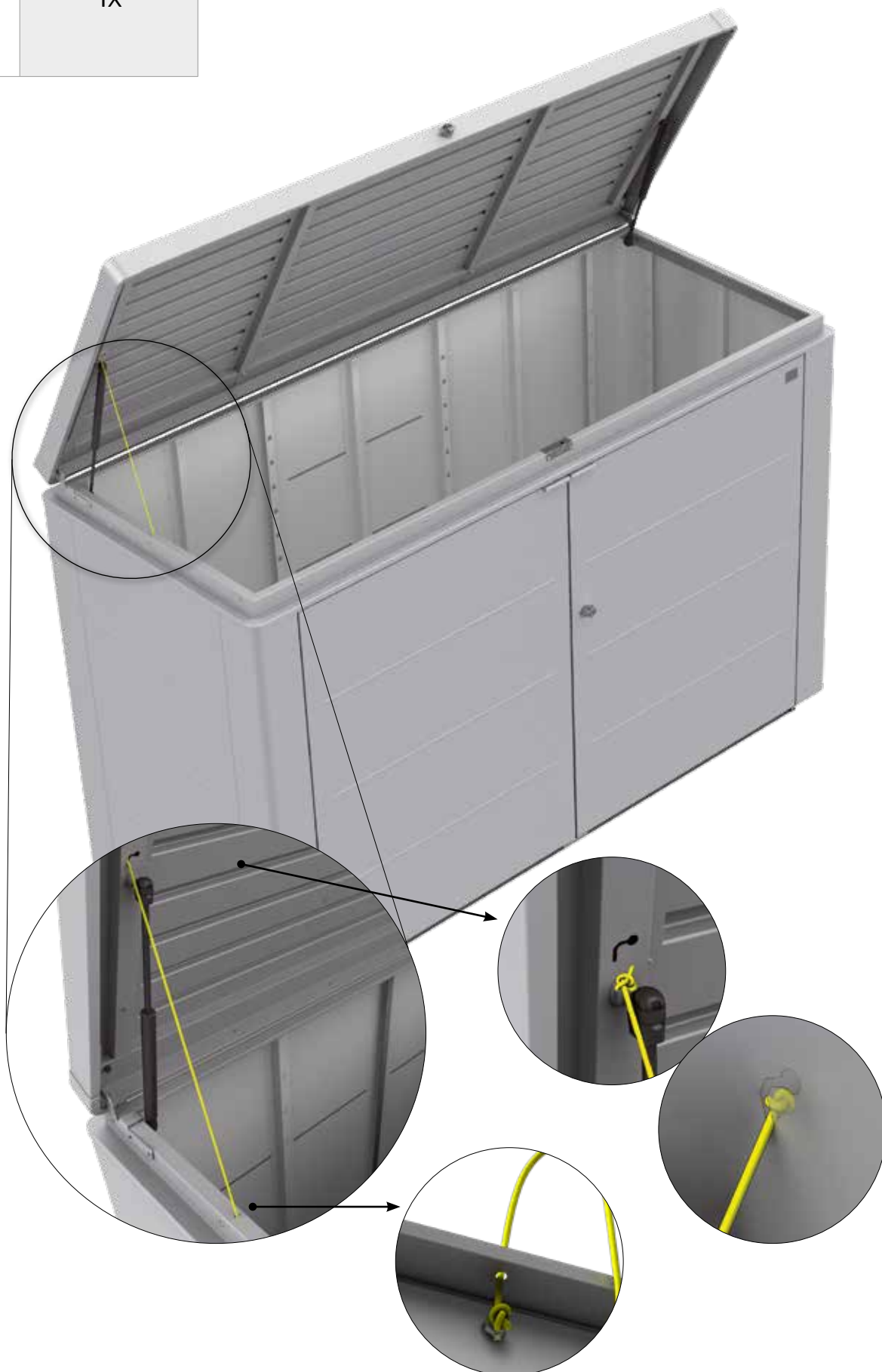

**IMPORTANT: SHARP EDGES! USE WORK GLOVES TO PREVENT INJURY!**

Ⓔ **ES** Importante: ¡Cantos afilados! Utilice guantes de trabajo para evitar lesiones.

Ⓔ **FR** Important : bords tranchants ! Utilisez des gants de travail pour éviter toute blessure !

27.

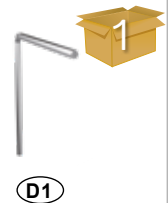
	2x		1x
---	----	---	----

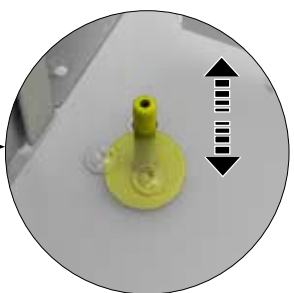
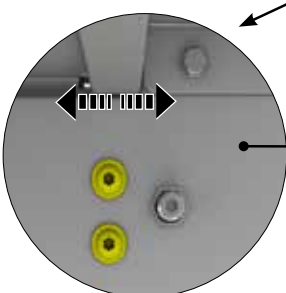
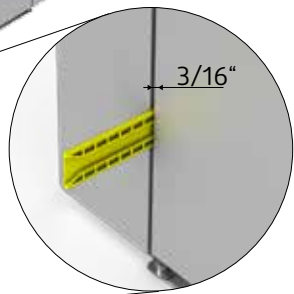
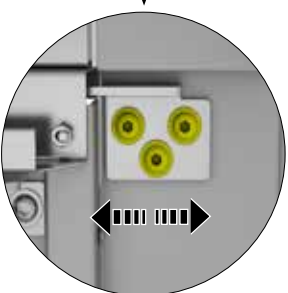
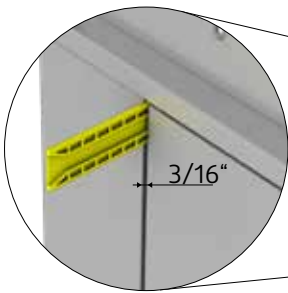
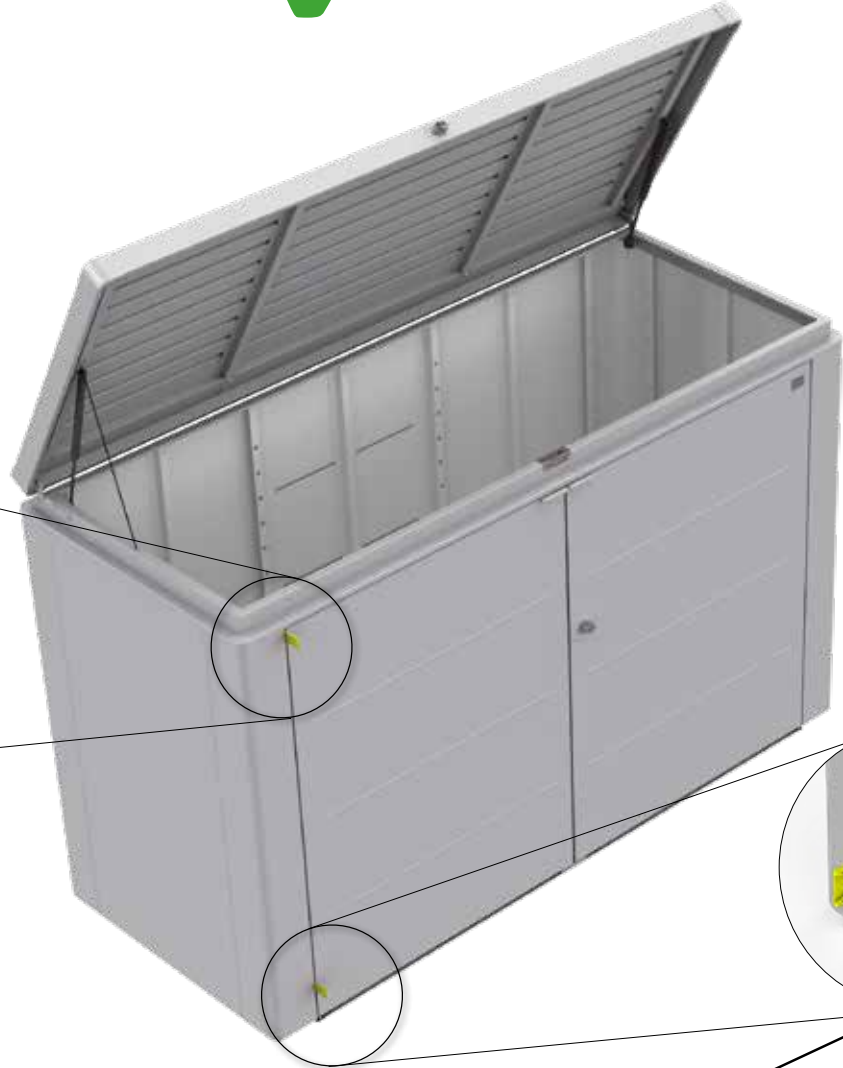
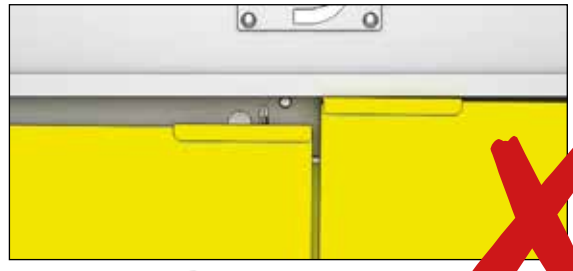
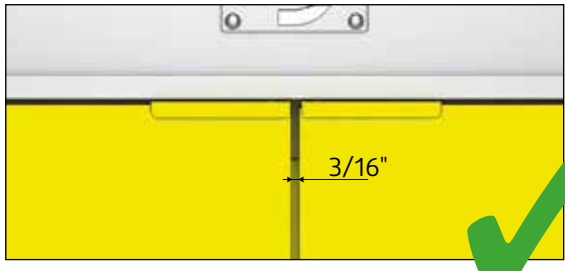



**! IMPORTANT: SHARP EDGES! USE WORK GLOVES TO PREVENT INJURY!**

(ES) Importante: ¡Cantos afilados! Utilice guantes de trabajo para evitar lesiones.

(FR) Important : bords tranchants ! Utilisez des gants de travail pour éviter toute blessure !

28.

 D2	6x	 D2	6x
---	----	---	----

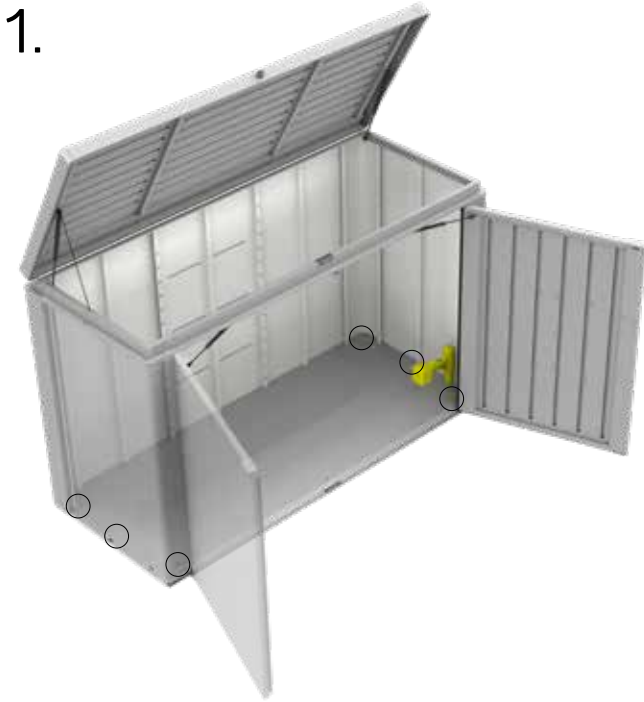

**! WARNING! FAILURE TO ANCHOR THE LOCKER MAY RESULT IN PROPERTY DAMAGE AND/OR PERSONAL INJURY.**

(ES) Advertencia. No anclar la caseta puede resultar en daños a la propiedad y/o en lesiones personales.

(FR) Avertissement! Si vous n'ancrez pas votre abri, des dommages à la propriété et/ou des blessures peuvent en résulter.

1. 

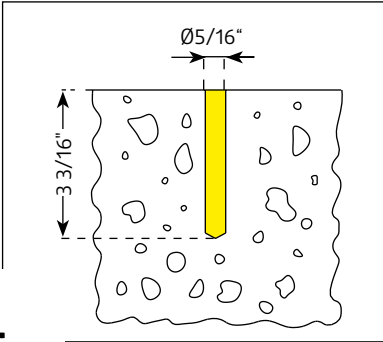
2. 

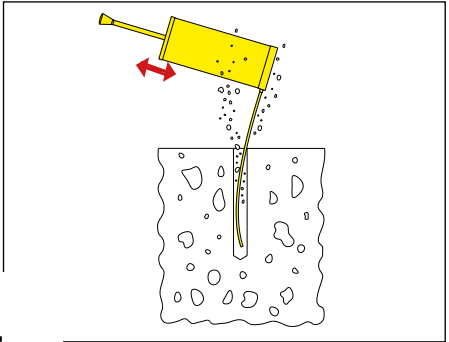
3. 

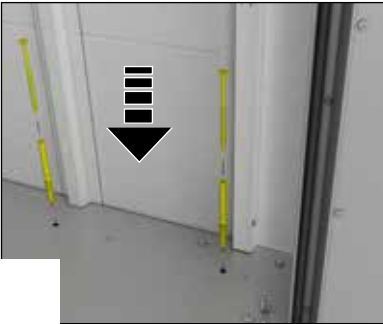
4. 

5. 

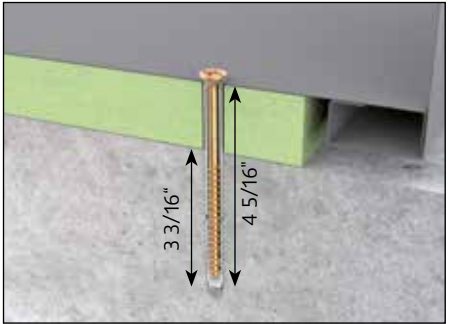



**! IMPORTANT: SHARP EDGES! USE WORK GLOVES TO PREVENT INJURY!**

(ES) Importante: ¡Cantos afilados! Utilice guantes de trabajo para evitar lesiones.

(FR) Important : bords tranchants ! Utilisez des gants de travail pour éviter toute blessure !

29.

 D2	3x	 D2	3x	 D2	3x
---	----	---	----	---	----

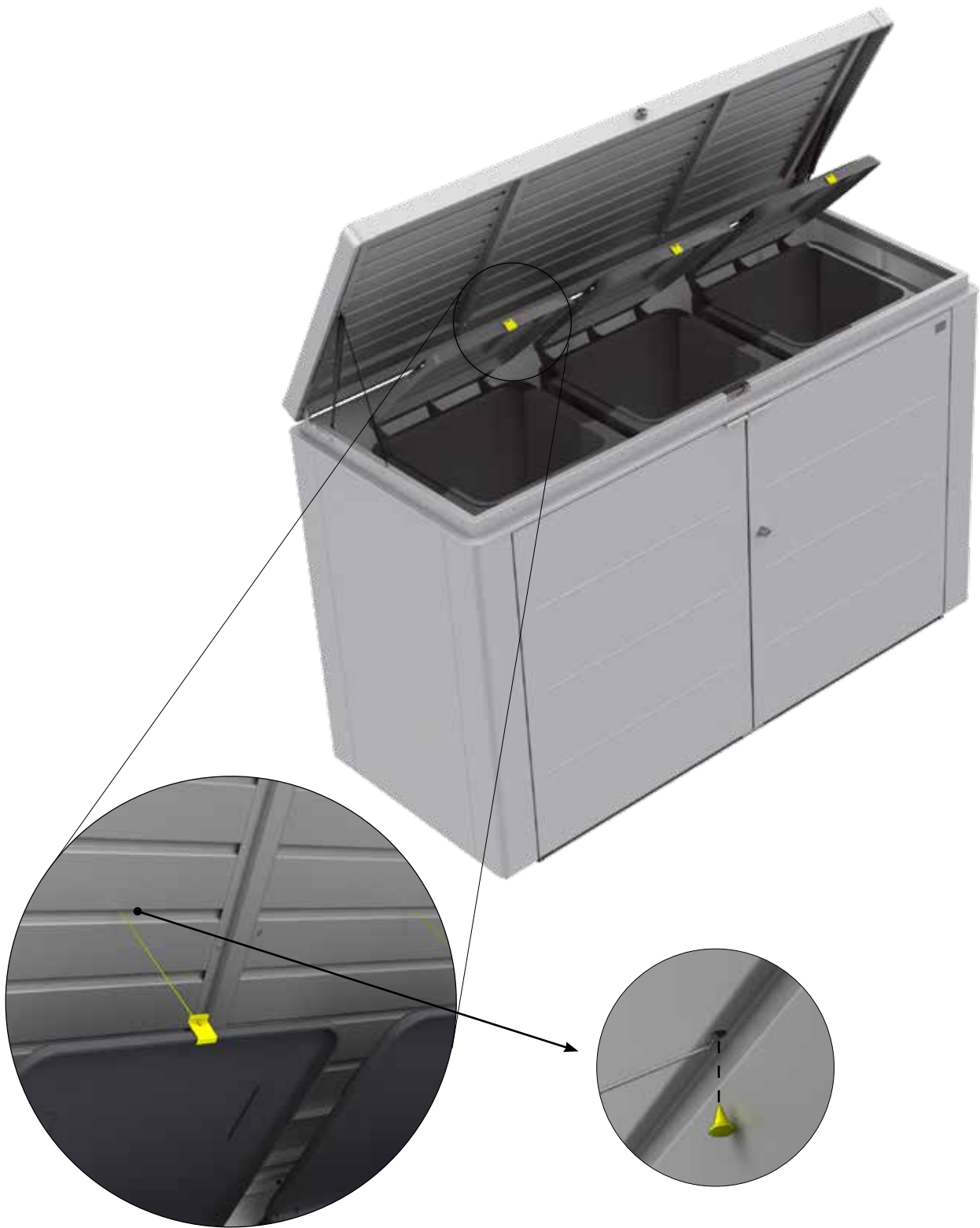

 **IMPORTANT: SHARP EDGES! USE WORK GLOVES TO PREVENT INJURY!**

ES Importante: ¡Cantos afilados! Utilice guantes de trabajo para evitar lesiones.

FR Important : bords tranchants ! Utilisez des gants de travail pour éviter toute blessure !



30.

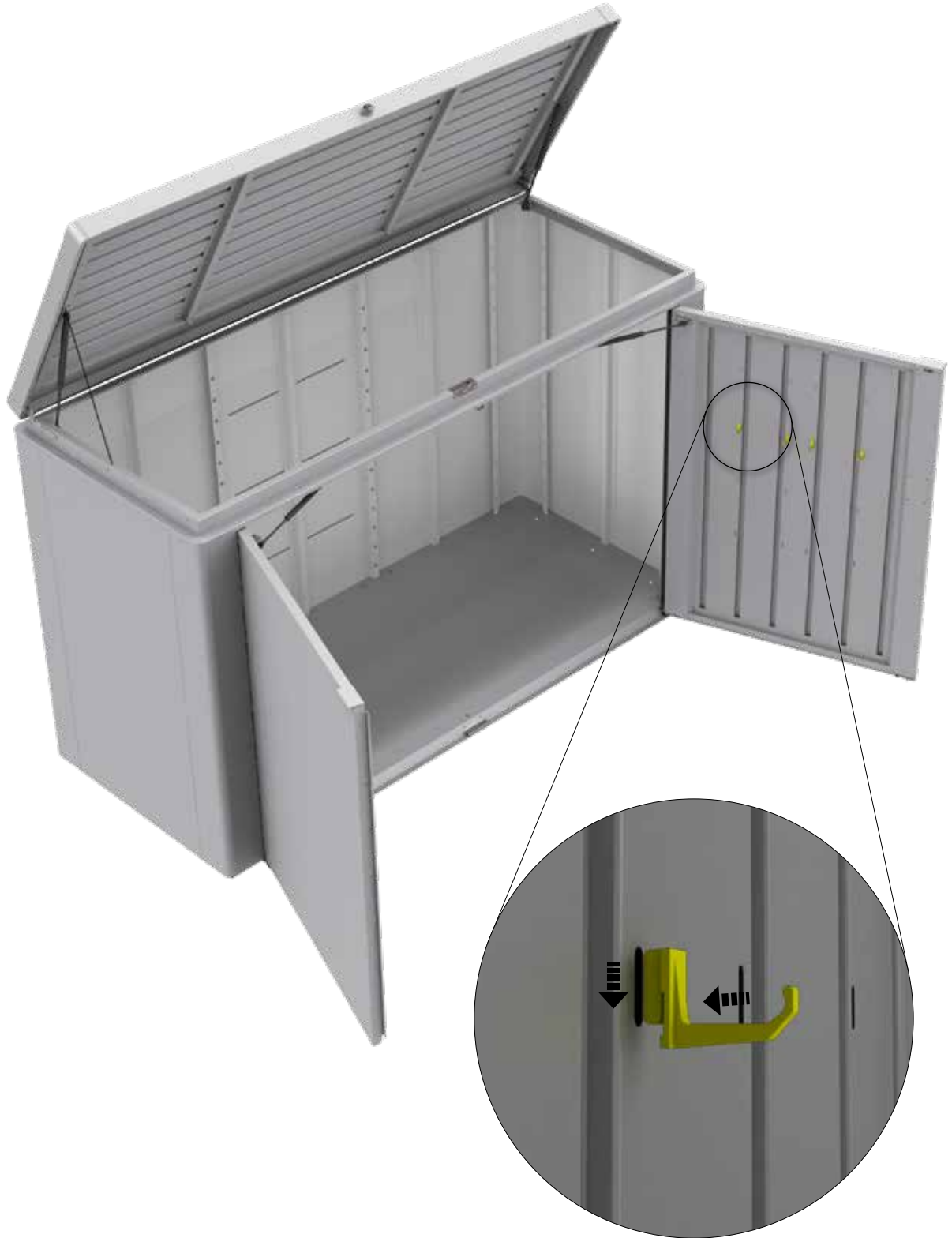
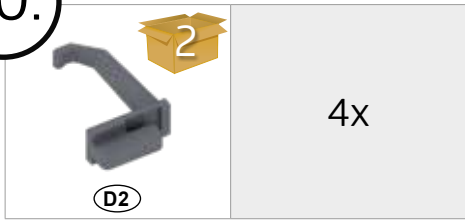

**IMPORTANT: SHARP EDGES! USE WORK GLOVES TO PREVENT INJURY!**

Ⓔ **ES** Importante: ¡Cantos afilados! Utilice guantes de trabajo para evitar lesiones.

Ⓔ **FR** Important : bords tranchants ! Utilisez des gants de travail pour éviter toute blessure !

## **PAGE INTENTIONALLY LEFT BLANK.**

- Ⓔ P gina dejada intencionalmente en blanco.
- Ⓕ Page intentionnellement laiss e blanche.

## **PAGE INTENTIONALLY LEFT BLANK.**

Ⓔ P gina dejada intencionalmente en blanco.

Ⓕ Page intentionnellement laiss e blanche.



**GARDEN SHEDS** – rely on quality & longevity



**OUTDOOR BOXES** – outdoor boxes for garden, patio & more



**BICYCLE STORAGE** – for safe storage of bicycles, scooters & more



**DUSTBIN STORAGE** – stylish, practical & maintenance free



**GARDENING HELPERS** – garden design at its best

**Poly-Tex Customer Service**  
 1750 126th St. W Suite  
 Burnsville, MN 55337  
 Phone: 844-693-6958  
 Email: biohortservice@poly-tex.com



Qualität in Bestform

Biohort stands for  
 „LIFE IN THE GARDEN“

Biohort Customer survey!

Your opinion is important to us!  
 Let us have your feedback about  
 our products and services.



Scan the QR code to participate.

follow us:

