

**ITEM # GEN4000**

Q

**4000 Surge Watts / 3500 Running Watts**

**PORTABLE GASOLINE GENERATOR INSTRUCTION MANUAL**



**Thank you for your purchase! If you have questions or problems with your generator, CALL CUSTOMER SERVICE.** If you experience a problem, have questions or need parts for this product, call Customer Service at **1-866-460-9436, Monday-Friday, 8 AM - 4 PM Central Time.** A copy of the sales receipt is required.

**ATTENTION!** This unit ships from our factory without oil. Fuel and oil must be added before operation.

**READ ALL INSTRUCTIONS AND WARNINGS BEFORE USING THIS PRODUCT.**

This manual provides important information on proper operation & maintenance. Every effort has been made to ensure the accuracy of this manual. These instructions are not meant to cover every possible condition and situation that may occur. We reserve the right to change this product at any time without prior notice.

**FOR CONSUMER USE ONLY – NOT FOR PROFESSIONAL USE.**

**KEEP THIS MANUAL, SALES RECEIPT & APPLICABLE WARRANTY FOR FUTURE REFERENCE.**



To register your product warranty, please visit [buffalotools.com](http://buffalotools.com) or scan the QR code.

# ITEM # GEN4000 Portable Gasoline Generator



## FEATURES:

- 4000 Surge Watts / 3500 Running Watts
- 4-Stroke OHV Engine 212cc
- Recoil Start
- 7.0 HP Gasoline Engine
- 1 - 12V D/C Outlet
- 4 - 120V A/C Outlets
- 1 - 120V RV Outlet
- Engine Run Time: 10 Hours @ 50% Load
- Low Oil Shutdown
- AVR Automatic Voltage Regulation
- EPA Approved
- Noise Level: 69dB @ 0% Load
- Oil Capacity: 18.5 ounces
- Fuel Capacity: 3.6 gallon
- Fuel Type: Unleaded Gasoline Only 87 rating or higher
- DO NOT use E85, gas/oil mix, or modify the engine to run on alternate fuels.
- 3,600 RPM
- Mobility Kit Available Separately
- If you are using a generator 3,000 feet above sea level, it may not function properly because of air flow getting through the carburetor.
- High Altitude Use: This generator is not recommended for high altitude use 3,000 feet above sea level.

## AC Output

Rated Voltage (V)	120
Running Watts (W)	3500
Rated Frequency (Hz)	60
Phase	Single

## DC Output

Voltage (V)	12
Circuit Breaker Amperage (A)	8

## Engine

Engine Type	4-stroke single cylinder with forced air cooling system
Ignition System	Non-contact transistor (T.C.I.)
Starting System	Recoil

# TABLE OF CONTENTS

RECOGNIZE SAFETY SYMBOLS, WORDS AND LABELS.....	4
PACKAGE CONTENTS	
PACKAGE CONTENTS .....	9
COMPONENTS .....	10
PREPARING THE GENERATOR FOR USE .....	11
Using This Generator For The First Time.....	11
Step 1 – Add Oil .....	11
Step 2 – Add Gasoline .....	12
Step 3 – Ground The Generator.....	12
Subsequent Use Of This Generator.....	13
Step 1 – Verify Oil Level .....	13
Step 2 – Verify Gas Level.....	13
Step 3 – Ground The Generator.....	13
STARTING THE GENERATOR.....	14
USING THE GENERATOR.....	15
AC Usage.....	15
DC Usage.....	16
STOPPING THE GENERATOR.....	17
MAINTENANCE/CARE .....	17
Recommended Maintenance Schedule .....	17
Cleaning The Generator.....	17
Checking The Oil Level .....	18
Changing/Adding Oil .....	19
Air Filter Maintenance .....	19
Changing Fuel Line .....	19
Spark Plug Maintenance .....	19
Emptying The Fuel Tank .....	19
STORAGE/TRANSPORT PROCEDURES .....	20
TROUBLESHOOTING .....	21
PARTS DIAGRAM .....	22
EMISSION CONTROL SYSTEM WARRANTY.....	28
CARBON DIOXIDE WARNING DETECTOR.....	30

# RECOGNIZE SAFETY SYMBOLS, WORDS AND LABELS

## What You Need to Know About Safety Instructions

Warning and Important Safety Instructions appearing in this manual are not meant to cover all possible conditions and situations that may occur. Common sense, caution and care must be exercised when operating or cleaning tools and equipment.

Always contact your dealer, distributor, service agent or manufacturer about problems or conditions you do not understand.



This is the safety alert symbol. It is used to alert you to potential personal injury hazards. Obey all safety messages that follow this symbol to avoid possible injury or death.



DANGER indicates an imminently hazardous situation which, if not avoided, will result in death or serious injury.



WARNING indicates a potentially hazardous situation which, if not avoided, could result in death or serious injury.



CAUTION indicates a potentially hazardous situation which, if not avoided, may result in minor or moderate injury.



CAUTION used without the safety alert symbol indicates a potentially hazardous situation which, if not avoided, may result in property damage.

## 2 YEAR LIMITED EMISSION-RELATED WARRANTY

THIS ENGINE MEETS U.S. EPA EMISSION STANDARDS UNDER 40 CFR 1054.625. The emission-related limited warranty is valid for two (2) years. Keep the purchase receipt and mail in the product registration card for proof of purchase. Buffalo Corp limits emission-related warranty repairs to authorized service centers for owners located within 100 miles of an authorized service center. For owners located more than 100 miles from an authorized service center, Buffalo Corp will, in its sole discretion, either pay for shipping costs to and from an authorized service center, provide for a service technician to come to the owner to make the warranty repair, or pay for the repair to be made at a local non-authorized service center. The provisions of this paragraph apply only for the contiguous states, excluding the states with high-altitude areas identified in 40 CFR part 1068, Appendix III.

To exercise this warranty, DO NOT RETURN TO RETAILER. Instead, call Customer Service toll free at 1-866-460-9436 (email address [info@buffalotools.com](mailto:info@buffalotools.com)) and you will be instructed on where to take the engine for warranty service. Take the generator and proof of purchase (your receipt) to the repair facility recommended by the Customer Service Representative. The warranty does not extend to generators damaged or affected by fuel contamination, accidents, neglect, misuse, unauthorized alterations, use in an application for which the product was not designed and any other modifications or abuse.

## 1 YEAR LIMITED WARRANTY (30 Day Limited Warranty for Commercial and Rental Purpose)

Generators are warranted to be free from defects in materials and workmanship for a period of 1 YEAR from date of original purchase. Buffalo Corp. is not liable for any indirect, incidental or consequential damages from the sale or use of this product. Any implied warranties are limited to 1 YEAR as stated, or as otherwise stated, in this written limited warranty. Some states do not allow the exclusion or limitation of incidental or consequential damages. Some states do not allow limitation on the length of an implied warranty. Buffalo Corp will repair or replace, at its discretion, any part that is proven to be defective in materials or workmanship under normal use during the 1 YEAR warranty period. Warranty repairs or replacements will be made without charge for parts or labor. Parts replaced during warranty repairs will be considered as part of the original product and will have the same warranty period as the original product. This warranty gives you specific legal rights, and you may have other rights that vary state to state.

### Notice Regarding Emissions:

Engines certified to comply with U.S. EPA emission regulations for SORE (Small Off Road Equipment) are certified to operate on regular unleaded gasoline and may include the following emission control systems: Three-Way Catalyst (TWC) (if equipped), and Engine Modifications (EM).

### Legal Requirements:

Federal and/or State Occupational Safety and Health Administration (OSHA) regulations, local codes, and/or ordinances may apply to the intended use of this generator. Consult a qualified electrician, electrical inspector, and/or the local agency having jurisdiction. Some areas require generators to be registered with local utility companies. Additional regulations may apply if this generator will be used at a construction site.

## IMPORTANT SAFETY INSTRUCTIONS

# STOP!

Before using this generator and if you have any questions regarding the hazard and safety notices listed in this manual and/or on this generator, call 1-866-460-9436, Monday - Friday, 8 AM - 4 PM Central Time.

### **WARNING**

**WARNING:** Do not connect this generator to a home or office electrical system. Connecting a generator to your electric utility company's power lines or to another power source could damage your generator and your appliances and could cause serious injury or even death to you or a utility worker who may be working on nearby power lines. Plug your appliances directly into the generator, do not plug the generator into any electric outlet in your home. Doing so could create a connection to the utility company power lines. You are responsible for ensuring that your generator's electricity does not feed back into the electric utility power lines.

### **WARNING**

**WARNING:** Do not use this generator to provide power for emergency medical equipment or life support devices.

### **DANGER**

**Carbon Monoxide Gas:** When in operation, the exhaust from this generator contains poisonous carbon monoxide gas. Carbon monoxide gas is both odorless and colorless AND may be present even if you do not see or smell gas. Breathing this poison gas can lead to headaches, dizziness, drowsiness, loss of consciousness and eventually death.

### **WARNING**

**WARNING:** USE THIS GENERATOR ONLY OUTDOORS IN NON-CONFINED AREAS. DO NOT SECURE THE GENERATOR WITH A CHAIN OR ROPE, AS THIS WILL MAKE IT DIFFICULT TO MOVE IN AN EMERGENCY.

- Keep at least several feet of clearance on all sides to allow proper ventilation for this generator.

### **CAUTION**

**Usage:** This generator is not intended to power sensitive electronic equipment such as TVs, DVD players, stereos, desktop computers or laptop computers without the use of an appropriate line conditioner and/or surge protector (both not included). Sensitive electronic equipment should be operated on approved inverter type generators or pure sine wave generators. For additional information consult the devices operation manual or call customer service at 1-866-460-9436 Monday - Friday, 8 AM - 4 PM Central Time.

### **WARNING**

**Usage:** Avoid the use of extension cords if possible. If you choose to use them, be sure they are sized adequately to handle the flow of electricity. An undersized cord can overheat, short out and cause a fire.

## **⚠ DANGER**

**Powerful Voltage:** This generator produces powerful voltage, which can result in electrocution.

- ALWAYS ground this generator before using it. (See “Ground the Generator” section in this manual).
- Only electrical devices should be plugged into this generator, either directly or with an extension cord. NEVER connect a building electrical system to this generator without a qualified electrician. **Doing so voids your warranty.** Such connections must isolate generator power from utility power and comply with local electrical laws and codes. Failure to comply can create a back feed into utility lines creating an electrocution hazard, which may result in serious injury or death to utility workers. Such a back feed may cause this generator to explode, burn and create fires when utility power is restored.
- Use a ground fault circuit interrupter (GFCI) in highly conductive areas such as metal decking or steel work. GFCIs are available in-line with some extension cords.
- Keep generator dry and operate with dry hands. Do not use this generator in wet conditions (rain, snow, active sprinkler system, wet hands, etc.).
- Do not touch bare wires or outlets (receptacles).
- Do not allow children or non-qualified persons to operate this generator.

## **⚠ WARNING**

**Flammable Gasoline:** This generator may emit highly flammable and explosive gasoline vapors, which can cause severe burns or even death. A nearby open flame can lead to an explosion even if not directly in contact with gasoline.

- Do not operate this generator near open flame.
  - Do not smoke near this generator.
  - Always operate this generator on a firm, level surface.
- Gasoline is highly flammable and explosive. Handling fuel can result in serious injury or burns.**
- Always shut down this generator before refueling. Refuel in a well-ventilated area. Keep heat, sparks and flame away while refueling and away from the location where gasoline is stored. Never refuel indoors where gasoline fumes may reach flames and/or sparks.
  - Allow this generator to cool for at least 2 minutes before removing the fuel tank cap. Loosen the cap slowly to relieve pressure in the fuel tank. Avoid spilling fuel.
  - Do not fill the fuel tank above the upper limit line. Gasoline may expand during operation. Do not fill to the top of the tank.
  - Always check for spilled gasoline and immediately wipe it up before starting this generator.
  - Empty the fuel tank before storing or transporting this generator.
  - Always handle fuel outdoors.
  - Before transporting, turn the fuel valve to the “OFF” position and disconnect the spark plug.

## **⚠ DANGER**

**High Temperatures:** This generator produces heat when in operation. Temperatures near the exhaust can exceed 150 Degrees Fahrenheit (65 Degrees Celsius).

- Do not touch hot surfaces. Observe all warning placards on this generator denoting hot surfaces.
- Allow this generator to cool for several minutes after use before touching the engine, muffler or other areas that are hot during operation and before storing indoors.
- Hot exhaust may ignite some materials. Keep flammable materials away from this generator.
- Keep at least several feet of clearance on all sides of this generator during operation. Do not enclose this generator in any structure.

## **⚠ CAUTION**

**Usage:** Misuse of this generator can damage it or shorten its life. Use this generator only for its intended purpose.

- Operate this generator only on a dry, level surface. Do not secure the generator with a chain or rope, which would prevent it from being moved in an emergency.
- Allow this generator to run for several minutes before connecting any electrical devices.
- Promptly turn off any malfunctioning devices and disconnect them.
- Do not operate an excessive number of electrical devices in excess of the wattage capacity of this generator.
- Do not turn on electrical devices until *after* they are connected to this generator.
- Turn off all connected electrical devices before stopping this generator.

## **⚠ WARNING**

**Usage:** Consult a physician(s) before using this generator if using a pacemaker. Electromagnetic fields in close proximity to a heart pacemaker could cause a pacemaker to malfunction or fail. Caution is necessary when near the engine's recoil starter.

## **⚠ CAUTION**

**Usage:** Prolonged exposure to high noise levels can be hazardous to hearing. Always wear ANSI-approved hearing protection when operating or working around the generator when it is running.

## **DANGER**

*EXHAUST CONTAINS POISONOUS CARBON MONOXIDE GAS THAT CAN BUILD UP TO DANGEROUS LEVELS IN CLOSED AREAS. BREATHING CARBON MONOXIDE CAN CAUSE UNCONSCIOUSNESS OR DEATH. Never run the generator in a closed or even partly closed area where people may be present.*

## **WARNING**

*GASOLINE IS HIGHLY FLAMMABLE AND EXPLOSIVE. YOU COULD BE BURNED OR SERIOUSLY INJURED IF THE GASOLINE IS IGNITED. Before refueling, stop the engine and keep heat, sparks and flame away. Handle fuel only outdoors. Do not fill the fuel tank above the upper limit line. Wipe up spills immediately.*

## **WARNING**

*IMPROPER CONNECTIONS TO A BUILDING CAN ALLOW ELECTRICAL CURRENT TO BACKFEED INTO UTILITY LINES, CREATING AN ELECTROCUTION HAZARD. Connections to a building must isolate generator power from utility power and comply with all applicable laws and electrical codes.*

In addition to the previously described safety information, familiarize yourself with all safety and hazard placards on this generator.

**⚠ DANGER POISONOUS GAS**

Generator exhaust contains toxic carbon monoxide gas. Breathing exhaust can cause loss of consciousness and shortness of breath. NEVER operate generator in poorly ventilated areas.

**⚠ WARNING**

Risk of electric shock. Do not remove cover. No user serviceable parts inside. Refer servicing to qualified service personnel.

**⚠ WARNING! RISK OF ELECTRIC SHOCK**

**This generator produces high voltage.**  
 Always ground properly before use.  
 Do not connect to any building electrical system.  
 Never use in rainy or wet conditions.  
 Never touch bare wires or receptacles.  
 Never allow children or non-qualified person to operate.



USE THIS GENERATOR ONLY OUTDOORS IN NON-CONFINED AREAS.  
 DO NOT SECURE THE GENERATOR WITH A CHAIN OR ROPE, AS THIS  
 WILL MAKE IT DIFFICULT TO MOVE IN AN EMERGENCY.

**⚠ CAUTION! HOT EXHAUST**

**⚠ DO NOT TOUCH**

**⚠ CAUTION!**  
**HIGH TEMPERATURE**  
**DO NOT TOUCH**

**⚠ DANGER**

Using a generator indoors CAN KILL YOU IN MINUTES.  
 Generator exhaust contains carbon monoxide. This is a poison you cannot see or smell.

NEVER use inside a home or garage. EVEN IF doors and windows are open.

Only use OUTSIDE and far away from windows, doors, and vents.



## PACKAGE CONTENTS

The following items are supplied with this Generator. Verify that all items are included.

# STOP!

If there are missing items, call 1-866-460-9436, Monday - Friday, 8 AM - 4 PM Central Time for customer service.

**HAVE QUESTIONS? CONTACT US FIRST BEFORE CONTACTING THE RETAILER.**

Item List:	
	DC connector wires for charging 12 Volt automotive-type batteries
	Spark plug wrench

\*

# GENERATOR COMPONENTS

Observe the locations and functions of the various components and controls of this generator.

- 1) Fuel Tank Cap
- 2) Control Panel
- 3) Oil Access
- 4) Fuel Cock
- 5) Carburetor Choke Lever
- 6) Air Filter Cover
- 7) Recoil Starter
- 8) AC Circuit Protector
- 9) Engine Switch
- 10) 120 Volt AC Outlet
- 11) DC Circuit Protector
- 12) 12 Volt DC Outlet
- 13) Grounding Terminal
- 14) 120 Volt RV Outlet
- 15) Voltmeter

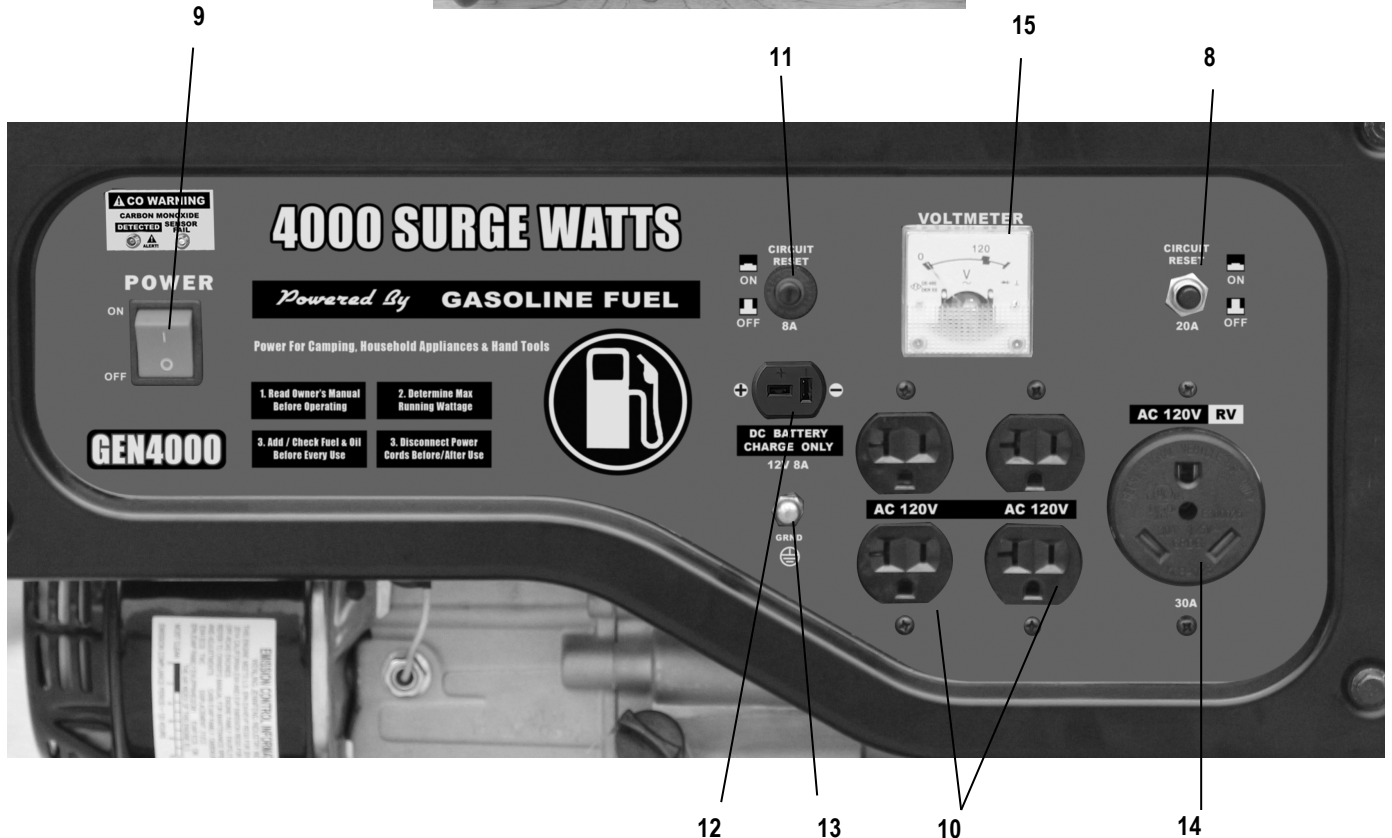
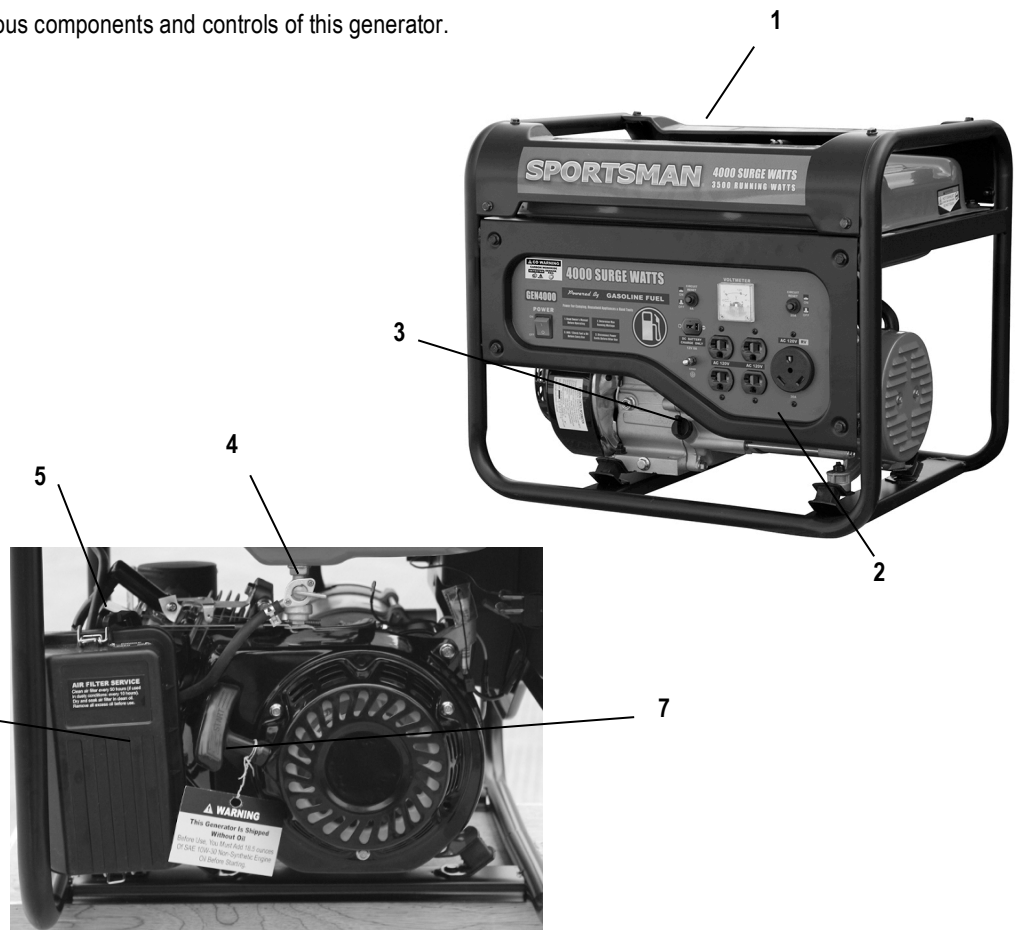

## PREPARING THE GENERATOR FOR USE

### Using this Generator for the First-Time

# STOP!

# CAUTION

The following section describes the required steps for preparing this generator for the first use. Failure to correctly perform these steps can damage this generator and/or shorten its life. If still unsure about how to perform any of these steps after reading this section, call 1-866-460-9436 Monday - Friday, 8 AM - 4 PM Central Time for customer service.

If this generator is being used for the first time, the following few steps are required to prepare it for operation:

#### **Step 1 - Add Oil**

**THIS GENERATOR REQUIRES AT LEAST 18.5 OUNCES OF OIL (SAE10W-30) TO RUN.**

**ADD OIL UNTIL IT IS ALMOST OVERFLOWING. THE LOW-OIL SENSOR IS VERY SENSITIVE AND THE ENGINE WILL NOT RUN IF THE OIL IS LOW. START WITH 18.5 OUNCES, THEN ADD MORE UNTIL ALMOST OVERFLOWING.**

**TROUBLESHOOTING:** IF THE GENERATOR WILL NOT START, DOUBLE CHECK THAT THE OIL LEVEL IS COMPLETELY FULL AND ALMOST OVERFLOWING.

**This generator requires engine oil to function. Engine oil is a major factor affecting engine performance and service life.** When new from the package, this generator contains no oil in the engine crankcase. Add oil before operating this generator for the first time. When replenishing oil for subsequent use of this generator, always determine that this generator has the correct quantity of oil.

To add oil to the engine crankcase:

1. Confirm that this generator is on a level surface.
2. Unscrew the oil filler/dipstick cap from the engine as illustrated in Figure 1A below.
3. Using a funnel, add high detergent motor oil to fill the engine crankcase to the correct quantity. SAE10W-30 oil is recommended for general use.

When the engine crankcase is full and almost overflowing, the oil level should reach the lower lip of the oil filling opening as shown in Figure 2.

4. Replace the oil filler/dipstick cap and close the oil access panel.

**Figure 1 A – Unscrew the Dipstick Cap**

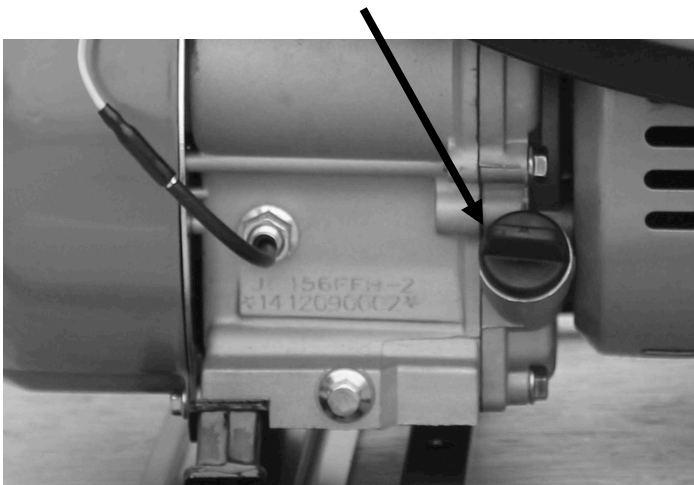

**Figure 2 - Add Oil**

## Step 2 - Add Gasoline

### **⚠ WARNING**

Gasoline and gasoline fumes are highly flammable and explosive. Handling fuel can result in serious injury or burns.

- Do not fill the fuel tank near a heat, sparks or an open flame. Keep gasoline away from appliance pilot lights, barbecues, electric appliances, power tools, etc.
- Do not overfill the fuel tank. Always check for fuel spills and immediately wipe them up. Spilled fuel is a fire hazard and causes environmental damage.

To add gasoline:

To ensure that this generator runs smoothly, use only FRESH, UNLEADED GASOLINE WITH AN OCTANE RATING OF 87 OR HIGHER. Unleaded gasoline produces fewer engine and spark plug deposits and extends the life of the exhaust system.

1. Confirm that this generator is on a level surface.
2. Unscrew fuel tank cap and set aside. (NOTE: The fuel tank cap may be tight and difficult to unscrew.)
3. Slowly add fresh, unleaded gasoline (with an octane rating 87 or higher) to the fuel tank. Be careful not to fill the fuel tank above the upper limit line. NOTE: Because gasoline can expand, do not fill the fuel tank to the very top.
4. Securely tighten the fuel tank cap and immediately wipe up any spilled gasoline with a dry cloth.

<b>Fuel Tank Capacity (gallons)</b>	3.6
<b>Fuel Type</b>	Fresh, Unleaded Gasoline Octane Rating 87 or Higher

### IMPORTANT:

- Use only UNLEADED gasoline with an octane rating of 87 or higher.
- Never use a mixture of oil and gasoline.
- Never use old and/or contaminated gasoline.
- Avoid getting dirt and/or water in the fuel tank.
- Gasoline can age in the fuel tank and make it difficult to start this generator. Never store this generator for extended time with gasoline in the fuel tank.

## Step 3 - Ground the Generator

### **⚠ WARNING**

Failure to properly ground this generator can result in electrocution.

Ground this generator by tightening the grounding nut against a grounding wire as illustrated in Figure 3. A No. 12 AWG (American Wire Gauge) stranded copper wire is generally an acceptable grounding wire. The other end of this grounding wire should be connected to a copper or brass grounding rod that is driven into the earth.

Grounding codes can vary by location. Contact a local electrician for information on grounding regulations for your area.

**Figure 3**  
The Grounding Terminal is located on the front of the generator, under the DC Output socket.

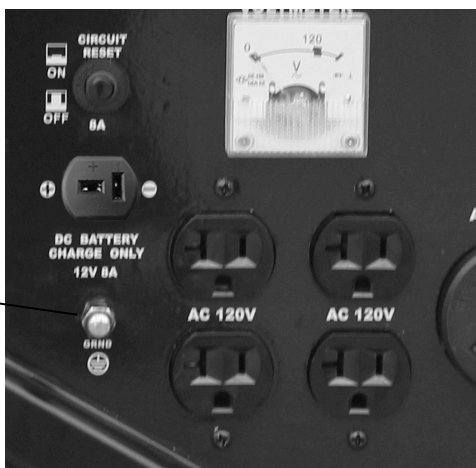

## Subsequent Use of this Generator

For subsequent uses of this generator after the first use, certain steps still must be completed to prepare it for operation.

**IMPORTANT: Be familiar with the procedures described in the previous section titled “Using the Generator for the First Time” of this manual. If not, review this section now.**

### Step 1 - Verify Oil Level

It is important to check the oil level in the engine crankcase before each use to ensure that there is sufficient quantity.

1. Verify that this generator is on a level surface.
2. Unscrew the oil filler/dipstick cap from the engine.
3. With a dry cloth, wipe the oil off of the dipstick that is located on the inside of the cap.
4. Fully insert the dipstick without screwing the filler/dipstick cap and then remove again. There should be oil on the dipstick. If there is no oil on the dipstick, or oil is visible only at the very end of the dipstick, add oil until the engine crankcase is filled. (See “Changing/Adding Oil” in the “Maintenance/Care” section of this manual).
5. Confirm that the oil filler/dipstick cap is properly screwed in place when finished verifying the oil level.

### Step 2 - Verify Gas Level

Before starting this generator, verify that there is sufficient gasoline in the fuel tank. If necessary, add fresh unleaded gasoline with an octane rating of 87 or higher according to “Step 2 - Add Gasoline” of the “Using this Generator for the First Time” section of this manual.

<b>Fuel Tank Capacity (gallons)</b>	3.6
<b>Fuel Type</b>	Fresh, Unleaded Gasoline Octane Rating 87 or Higher

#### **⚠ WARNING**

**Gasoline and gasoline fumes are highly flammable and explosive. Handling fuel can result in serious injury or burns.**

- Do not fill the fuel tank near a heat, sparks or an open flame. Keep gasoline away from appliance pilot lights, barbecues, electric appliances, power tools, etc.
- Always allow several minutes for the engine to cool before refueling.
- Do not overfill the fuel tank. Always check for fuel spills and immediately wipe them up. Spilled fuel is a fire hazard and causes environmental damage.

#### **IMPORTANT:**

- Use only fresh UNLEADED gasoline with an octane rating of 87 or higher.
- Never use old and/or contaminated gasoline.
- Never use a mixture of oil and gasoline.
- Avoid getting dirt and/or water in the fuel tank.
- Never store generator for extended time with gasoline in the fuel tank.

### Step 3 - Ground the Generator

#### **⚠ WARNING**

**Failure to properly ground this generator can result in electrocution.**

Ground this generator by tightening the grounding nut against a grounding wire as previously illustrated in Figure 3. A generally acceptable grounding wire is a No. 12 AWG (American Wire Gauge) stranded copper wire. The other end of this grounding wire should be connected to a copper or brass grounding rod that is driven into the earth.

Grounding codes can vary by location. Contact a local electrician for information on grounding regulations for your area.

## STARTING THE GENERATOR

# STOP!

Before starting this generator, confirm that all the steps in the section titled, “Preparing the Generator for Use,” of this manual have been correctly completed. If unsure about how to perform any of these steps, call 1-866-460-9436, Monday - Friday, 8 AM - 4 PM Central Time for customer service.

### **CAUTION**

Disconnect all electrical loads from this generator before attempting to start.

To start this generator:

1. Confirm that there are no electrical devices connected to this generator. Connected devices may increase the difficulty in starting the engine.
2. Confirm that this generator is properly grounded. (See “Ground the Generator” section of this manual.)
3. Turn the fuel valve to the “on” position.
4. Move the choke lever to the “Closed/Choke” position.
5. Set the engine switch to the “on” position.
6. Slowly pull on the recoil starter handle, shown in Figure 4, until a slight resistance is felt. Then pull briskly to start the engine. Gently return the cord into the generator to avoid damage to the starter or housing. Never allow the cord to snap back.
7. If the engine fails to start, repeat step 6. NOTE: After repeated attempts to start the engine, consult the troubleshooting guide before attempting again. If problems persist, call 1-866-460-9436, Monday - Friday, 8 AM - 4 PM Central Time.
8. Once the engine has started, GRADUALLY move the choke lever to the “Open/Run” position until the engine levels off. Then let the engine run approximately 5 minutes BEFORE adding appliances or tools.

### Fuel Cock

The fuel cock is located between the fuel tank and carburetor. When the fuel cock is in the ON position, fuel is allowed to flow from the fuel tank to the carburetor. Be sure to return the fuel cock to the OFF position after stopping the engine.

### Choke Rod

The choke is used to provide an enriched fuel mixture when starting a cold engine. It can be opened and closed by operating the choke rod manually. Pull the rod out toward CLOSED to enrich the mixture for cold starting



Figure 4  
The Recoil Start is located on the left side of the generator.

## USING THE GENERATOR

### **⚠ WARNING**

- USE THIS GENERATOR ONLY OUTDOORS IN NON-CONFINED AREAS. DO NOT SECURE THE GENERATOR WITH A CHAIN OR ROPE, AS THIS WILL MAKE IT DIFFICULT TO MOVE IN AN EMERGENCY.
- Keep at least several feet of clearance on all sides to allow proper ventilation for this generator.

After the engine has been running for several minutes, electrical devices may be connected to this generator.

### AC Usage

Electrical devices running on AC current may be connected according to their wattage requirements.

<b>Rated (Running) Wattage</b>	3500
<b>Surge Wattage</b>	4000

The *rated (running) wattage* corresponds to the maximum wattage a generator can output on a continuous basis.

The *surge wattage* corresponds to the maximum amount of power a generator can output for a short time. Many electrical devices, such as a refrigerator, require short bursts of extra power for starting and stopping fan motors, etc., in addition to their listed rated wattage. Motorized devices typically require more than their rated wattage for startup. The surge wattage ability of a generator allows for this extra power requirement.

The total running wattage requirement of the electrical devices connected to a generator should not exceed the rated wattage of the generator itself. To calculate the total wattage requirement of the electrical devices to be connected, look up the rated (running) wattage of each device and add these numbers together to find the total wattage that all of the devices together will draw from the generator. If the total wattage of the selected devices exceeds the rated wattage of the generator, DO NOT connect all of the devices. Select a combination of the electrical devices that will have a total wattage less than or equal to the rated wattage for the generator.

### **⚠ CAUTION**

**This generator can run at its surge wattage capacity for only a short time. Connect electrical devices requiring a rated (running) wattage equal to or less than the rated wattage of this generator. Never connect devices requiring a rated wattage equal to the surge wattage of a generator.**

A device's rated (running) wattage should be listed somewhere on the device itself and/or in its manual. If the wattage specification for a device is not available, the wattage can be calculated by multiplying the Voltage requirement (120) by the Amperage drawn.

Watts = Volts x Amperes

Or, the wattage required by a device can be estimated by using the following chart. The chart provides only estimates and it is better to know the exact wattage of each electrical device to be powered by this generator. **Some items may require up to 3 times the listed starting watts.**

Electrical Device	Rated (Running) Watts	Additional Surge Watts
air compressor (1 - 1/2 HP)	2500	2500
airless sprayer (1/3 HP)	600	1200
coffee maker	1500	0
computer w/17 inch monitor	800	0
electric drill (1/2 HP)	1000	1000
furnace fan blower (1/2 HP)	800	1300
hot plate	2500	0
microwave oven (1000 watt)	1000	0
quartz halogen work light	1000	0
refrigerator/freezer (18 Cu. Ft.)	800	1600
saw - circular (7 1/4 inch)	1500	1500
stereo receiver	450	0
electric stove - single element	1500	0
sump pump	800	1200
television (27 inch color)	500	0
well water pump (1/3 HP)	1000	2000
window fan	300	600

### **⚠ CAUTION**

**Connect only electrical devices that are in good working order. Faulty devices or power cords present the risk of electrical shock. Immediately turn off and disconnect any device that commences to operate abnormally, sluggish or abruptly stops. Determine if the problem was the device or the rated load capacity of this generator has been exceeded.**

**NOTE:** Plug appliances into the correct outlet. Connect standard 120 Volt, single phase, 60 Hz loads to the 120 Volt outlet. Connect 12 Volt, DC loads to the 12 Volt outlet.

**⚠ CAUTION**

Even though this generator has an overall rated wattage of 4000, do not attempt to draw more than 3500 Watts from the 120 Volt outlet. Draws higher than 3500 Watts will damage this generator and void the warranty.

**NOTE:** While this generator is running, power is available from either the standard 120 Volt outlet or the 12 Volt DC outlet. Both 120 Volts and 12 Volts can be simultaneously drawn from this generator.

Turn on the connected electrical devices beginning with the device with the highest rated wattage requirement and then each additional device with the next lower rated wattage requirement.

**⚠ CAUTION**

Do not connect 50Hz or 3-phase loads to this generator.

### DC Usage

**⚠ CAUTION**

- The DC outlet is for charging 12 Volt battery, up to 8 Amps.
- NEVER attempt to jumpstart a car with this generator.

**⚠ DANGER**

Do not secure the generator with a chain or rope, which would prevent it from being moved in an emergency.

### To Plug Items Into the Generator

1. Allow the engine to run for several minutes after it has been started.
2. Confirm that the electrical device is switched off prior to plugging it into this generator.
3. Turn on the connected electrical devices beginning with the device with the highest rated wattage requirement and then each additional device with the next lower rated wattage requirement.

### SOME NOTES ABOUT POWER CORDS

Long or thin cords can require more wattage from a generator to power an electrical device. Figure 6 shows the recommended cords according to the power requirement of the electrical device. When using cords that exceed these specifications, allow for the electrical device to have a slightly higher rated wattage requirement.

Device Requirements			Max. Cord Length (ft) by Wire Gauge				
Amps	Watts (120V)	Watts (240V)	#8 wire	#10 wire	#12 wire	#14 wire	#16 wire
2.5	300	600	NR	1000	600	375	250
5	600	1200	NR	500	300	200	125
7.5	900	1800	NR	350	200	125	100
10	1200	2400	NR	250	150	100	50
15	1800	3600	NR	150	100	65	NR
20	2400	4800	175	125	75	50	NR
25	3000	6000	150	100	60	NR	NR
30	3600	7200	125	65	NR	NR	NR
40	4800	9600	90	NR	NR	NR	NR

Figure 6 - Maximum Extension Cord Lengths by Power Requirement

# STOPPING THE GENERATOR

To stop this generator:

1. Turn off all connected electrical devices and then unplug them.
2. Allow this generator to run for several more minutes with no electrical devices connected to help stabilize the temperature of this generator.
3. Set the engine switch to the "OFF" position.
4. Turn the fuel valve to the "OFF" position.

**⚠ WARNING**

Allow this generator to cool down before touching areas that become hot during operation.

**⚠ CAUTION**

Allowing gasoline to sit in this generator's fuel tank for extended time without use can increase the difficulty in starting this generator in the future. Never store this generator for extended time with gasoline in the fuel tank.

## MAINTENANCE/CARE

Proper routine maintenance of this generator is essential for safe, economical, and trouble-free operation. It will help prolong the life of this generator as well as help reduce air pollution. Perform maintenance checks and procedures according to the schedule in Figure 7.

**⚠ CAUTION**

Never perform maintenance procedures while this generator is running. Allow this generator to cool before commencing any maintenance procedures. Keep heat, sparks and flame away.

**⚠ WARNING**

Improper maintenance and/or failure to correct any problems prior to operating this generator can cause a malfunction which could cause death or serious injury. Always follow the inspection and maintenance recommendations and schedules in this manual.

### Recommended Maintenance Schedule

		Each Use	Every Month or Each 20 Hrs	Every 3 Months or Each 50 Hrs	Every 6 Months or Each 100 Hrs	Every Year or Each 300 Hrs
Engine Oil	Check Level	X				
	Replace		X (first use)		X	
Air Filter	Check	X				
	Clean			X		
Spark Plug	Check/Clean				X	
Fuel Tank	Verify Gas Level	X				
	Clean					X

Figure 7 - Recommended maintenance schedule

### Cleaning the Generator

Always try to use this generator in a cool dry place. If this generator becomes dirty, the exterior can be cleaned with a damp cloth, soft brush, vacuum and/or pressurized air.

Never clean this generator with a bucket of water and/or a hose as water can get inside and cause a short circuit or corrosion.

Never use gasoline to clean parts of this generator.

## Checking the Oil Level

It is important to check the oil level in the engine crankcase before each use to ensure that there is a sufficient quantity.

To check the oil level:

1. Verify that this generator is shut down and on a level surface.
2. Unscrew the oil filler/dipstick cap from the engine.
3. With a dry cloth, wipe the oil off of the dipstick that is located on the inside of the cap.
4. Insert the dipstick as if replacing the cap and then remove again. There should be oil on the dipstick. If there is no oil on the dipstick, or oil is visible only at the very end of the dipstick, add oil until the engine crankcase is filled.
5. Confirm that the oil filler/dipstick cap is properly in place when finished verifying the oil level.

## Changing/Adding Oil

The oil level in this generator should be checked before each use. When the oil level is low, add oil until the level is sufficient to operate this generator. (See Figure 8B)

The oil should be changed after the first 20 hours of operation. Subsequently, the oil should be changed every 6 months, or for every 100 hours of use, or when the oil has become contaminated with water and/or dirt.

To drain the oil from this generator:

1. Place a bucket underneath this generator to catch oil as it drains.
2. Unscrew the oil drain plug located on the crankcase underneath the oil filler/dipstick cap using 12 mm hex wrench. Figure 8A
3. Allow all the oil to drain from this generator.
4. Replace the oil drain plug and tighten using 12 mm hex wrench.

**NOTE: Never dispose of used motor oil in the trash, down a drain or on the ground. Put oil in a sealed container and contact your local recycling center or auto garage to arrange oil disposal.**

**THIS GENERATOR REQUIRES AT LEAST 18.5 OUNCES OF OIL (SAE10W-30) TO RUN.**

**ADD OIL UNTIL IT IS ALMOST OVERFLOWING. THE LOW-OIL SENSOR IS VERY SENSITIVE AND THE ENGINE WILL NOT RUN IF THE OIL IS LOW. START WITH 18.5 OUNCES, THEN ADD MORE UNTIL ALMOST OVERFLOWING.**

**TROUBLESHOOTING: IF THE GENERATOR WILL NOT START, DOUBLE CHECK THAT THE OIL LEVEL IS COMPLETELY FULL AND ALMOST OVERFLOWING.**



Figure 8A – Use 12mm hex wrench to REMOVE bolt and drain oil



Figure 8B – Adding oil

## Runtime

Under optimal conditions, a portable generator can run continuously on a tank of fuel, without stopping and refueling, but not longer. However, heat build-up while running your generator can affect both runtime and performance. If the external temperature is hot, or the generator is running at higher watts, the generator could overheat. When running your generator in warm or hot weather, position it in a shady area and/or use a fan to cool the engine. Running the generator at a lower wattage and keeping it cool can improve runtime and performance.

## Air Filter Maintenance

Routine maintenance of the air filter helps maintain proper airflow to the carburetor. Occasionally verify that the air filter is free of excessive dirt. The air filter will require more frequent cleaning when operating this generator in extremely dusty areas.

To clean the air filter, remove the foam filter element from the generator and wash it in warm water and household dish detergent. Thoroughly rinse and dry. Pour a small amount of motor oil onto the filter, ring out ALL excess oil, and reinstall the foam filter element in the generator.

Unscrew the bolts, or unsnap the clips at the top and bottom of the air filter cover, located below the choke lever, to access the foam filter element.

## Spark Plug Maintenance

The spark plug is essential for proper engine operation. The spark plug should be intact, free of deposits, and properly gapped. A bad or incorrectly installed spark plug can cause engine damage. To inspect the spark plug:

1. Remove the spark plug by pulling on the spark plug cap.
2. Unscrew the spark plug from this generator by using the included spark plug wrench.
3. Visually inspect the spark plug. If it is cracked and/or chipped, discard and install a new spark plug. A F7RTC spark plug, such as NGK BPR7ES is recommended.
4. Measure the spark plug electrode gap with a gauge. The gap should be 0.020-0.028in (0.5-0.7mm). (See Figure 9.)
5. If re-using the spark plug, use a wire brush to clean any dirt from around the spark plug base and then re-gap the spark plug.
6. Screw the spark plug back into place on this generator by using the included spark plug wrench.
7. Replace the spark plug cap.

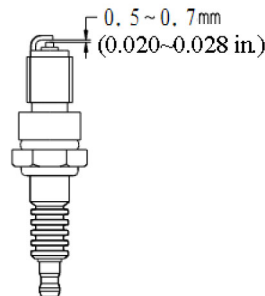

## Changing Fuel Line

Fuel line installation instruction (include the carburetor and the fuel tank ,etc. ) .

1. Connect clamp(Φ7.5) to the fuel hose.
2. Slide fuel hose onto connection until it touches the bottom.
3. Then secure with clamp.

Figure 9 Measuring the spark plug gap

## To store this generator for extended time, drain the gasoline from the carburetor AND fuel tank.

To drain gasoline from this generator:

1. Turn the fuel valve to the “off” position and let the engine run until it stops.
2. Remove the fuel filter cup.
3. Empty the fuel filter cup of any fuel.
4. Place a receptacle underneath this generator to catch gasoline as it drains.
5. Turn the fuel valve to the “on” position and allow all gasoline to drain.
6. Turn the fuel valve to the “off” position.
7. Replace the fuel filter cup.
8. Store the drained gasoline in a suitable place.

To store this generator for extended time, the fuel needs to be drained from the carburetor. To drain the gasoline from the carburetor turn the fuel valve to the “off” position while the engine is running. The generator will shut down when all the gasoline in the carburetor has been used.

## STORAGE/TRANSPORT PROCEDURES

**⚠ CAUTION**

Do not store generator with gasoline in fuel tank for more than 3 months.

**⚠ CAUTION**

Never place any type of storage cover on this generator while it is still hot.

When transporting or storing this generator for extended time:

- Allow generator to fully cool before moving it. A hot engine and exhaust system can burn you and ignite some materials.
- Empty the fuel tank. (See “Emptying the Fuel Tank” in the “Maintenance/Care” section.)
- Turn the fuel valve to the “off” position.
- Disconnect the spark plug.
- Do not obstruct any ventilation openings.
- Do not drop or strike this generator while moving it.
- Store this generator in a cool dry area, free of excessive dust.

<b>Storage Time</b>	<b>Recommended Storage Procedure</b> (which will help prevent difficult starts)
Less than 1 month	No storage procedure required.
1 to 2 months	Fill with fresh gasoline and add gasoline conditioner
2 months to 1 year	Empty the fuel tank. (See “Emptying the Fuel Tank” in the “Maintenance/Care” section.)
1 year or more	Empty the fuel tank. (See “Emptying the Fuel Tank” in the “Maintenance/Care” section.) Disconnect the spark plug.

## TROUBLESHOOTING

**IMPORTANT:** If trouble persists, call our customer help line at 1-866-460-9436, Monday - Friday, 8 AM - 4 PM Central Time.

Symptom	Cause	Solution
Engine will not start.	Engine switch is set to "off."	Set engine switch to "on."
	Fuel valve is turned to "closed."	Turn fuel valve to "open."
	Choke is set to "Open/Run".	Set the choke to "Closed/Choke"
	Engine is out of gasoline.	Add gasoline.
	Engine is filled with contaminated or old gas.	Drain gas from the engine and add new gas.
	Spark plug is dirty.	Clean spark plug.
	Spark plug boot is cracked.	Replace spark plug.
	Spark plug is broken.	Replace spark plug.
	Oil is low.	Oil level should almost OVERFLOW.
Engine will not start.	Spark plugs not sparking.	Verify that you have spark. Pull spark plug cap off spark plug. Take spark plug out using spark plug wrench. Put spark plug back into boot and hold it onto bare metal. Make sure the on/off switch is in the ON position. Pull the starter, look for spark.
Engine will not start.	Carburetor is gummed up.	If the generator has been sitting for a long time, it is possible that it is gummed up. Remove air box cover, then remove the air filter. Remove the two 10mm nuts that hold the carburetor. Lift up on the throttle linkage on the top of the carburetor. It should pop off. Pull the fuel line off. The carburetor will slide off. Turn the carburetor upside down and remove the 10mm bolt on the bottom of the bowl. Remove the pin that holds the float on. Pull the float up. Inspect the float needle, and make sure the orifice is not gummed up. Remove the rubber gasket, then clean the orifice if it is dirty. Use carb cleaner. Do not spray carb cleaner on the float needle or any rubber.
Engine will not start.	Gas is not getting to carburetor.	Make sure gas is getting to the carburetor. Remove the carburetor and turn the drain screw counter clockwise. Don't remove completely.
Engine will not start.	Two wires on the back of the switch may be disconnected.	Make sure two wires on back of switch are connected.
Engine runs but there is no electrical output.	Reset button is "off."	Push reset button to "on."
	Bad connecting wires/cables.	Try a different extension cord.
	Bad electrical device connected.	Disconnect device, try connecting another device.
	Generator is overloaded.	Reduce draw on generator to within this generator's rated wattage by reducing number of connected electrical devices.
Generator starts but won't stay running	Choke is in "Closed/Choke" position, or gas is empty.	After it is started, move the Choke to the "Open /Run" position. At least one inch of gas in the tank.
Generator runs but does not support all connected electrical devices.	Short in one of the connected devices.	Disconnect any faulty or short-circuited electrical loads.
	Air filter is dirty.	Clean or replace air filter.
If the engine starts and runs, but does not produce power, or power is too low.	AVR shorted out or burned out	Plug in voltmeter on VAC, see what volts are. It should be 110 -120. If too high or too low, adjust governor screw (located above pull start on the green metal shroud). WARNING – DO NOT ADJUST GOVERNOR SCREW WITHOUT USING A VOLTMETER. ONLY ATTEMPT IF YOU ARE FAMILIAR WITH USING IT. Property damage could occur. Turn it clockwise to turn volts up and kick the idle up. You may compensate for the increased idle from the governor screw with the idle screw.

# PARTS DIAGRAM

## CRANKCASE ASSEMBLY

NO.	PART NO.	DESCRIPTION	QTY
1	GB/T16674.1-2004	Bolt M8x30	6
2	QJ168QDJ.01-01B	Cover, Crankcase	1
3	JF142F.8-5	Oil Seal, Dipstick	1
4	QJ168QDJ .01-04	Dipstick	1
5	157.3-8	Guide Dowel $\phi 8 \times 14$	2
6	QJ168QDJ .01-02	Gasket, Crankcase	1
7	GB/T16674.1-2004	Bolt M6x12	2
8	QJ168FJH-3.01.02	Oil level sensor components	1
9	QJ168QDJ.01.01	Oil Seal $\phi 25 \times \phi 41.25 \times 6$	2
10	GB/T276-94	Bearing 6205/P53	2
11	QJ166QDK.01-07	Washer, Drain Plug	2
12	QJ166QDK.01-06	Drain Plug	2
13	JF170FLH.01.01	Crankcase Body	1
14	157.4-6	Guide Dowel $\phi 10 \times 14$	2

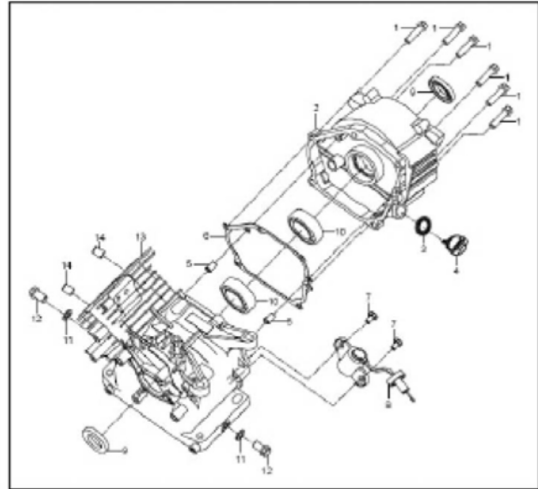

## CYLINDER HEAD

NO.	PART NO.	DESCRIPTION	QTY
1	JF170FLH.02.02	Gasket, Cylinder Head	1
2	GB/T16674.1-2004	Bolt, Cylinder Head M8x60	4
3	QJ168QDL.02.01C	Cylinder Head Assembly	1
4	GB/T6177.1-2000	Nut M6	2
5	JF152FFH.02-06	Double End Stud	2
6	QJ168QDJ.02-05	Gasket, Intake 1	1
7	QJ168QDJ.02-02	Spacer, Heat Insulating	1
8	QJ168QDJ.02-04	Gasket, Intake 2	1
9	QJ168QDJ.02-06	Gasket, Cylinder Head Cover	1
10	JF168FJH-15.02.01B	Cylinder Head Cover	1
11	GB/T5789-1986	Bolt M6x14	4
12	QJ1E50FMG.1.2	Spark Plug	1
13	QJ168QDJ.02-07	Double End Stud	2

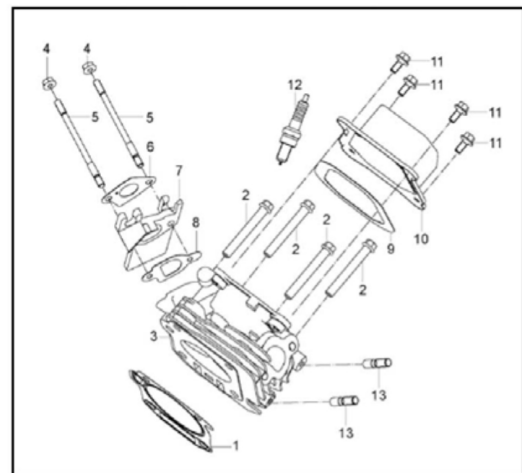

## VALVE ASSEMBLY

NO.	PART NO.	DESCRIPTION	QTY
1	QJ166QDK.03-11	Nut, Valve Clearance Adjustment	2
2	QJ182QDP.03-07	Button head, Arm	2
3	QJ168QDJ.03-09	Arm	2
4	QJ168QDJ.03-02	Cap, Exhaust Rod	1
5	QJ168QDJ.03-10	Upper Retainer, Exhaust Valve Spring	1
6	QJ168QDJ.03-07	Spring, Valve	2
7	QJ168QDJ.03-05C	Valve, Exhaust	1
8	QJ168QDJ.03.04	Guide Plate, Connecting Stud	1
9	QJ168QDJ.03.02	Push Rod	2
10	QJ168QDJ.03-08	Upper Retainer, Intake Valve Spring	1
11	QJ182QDP.03-04	Adjusting Stud, Valve Clearance	2
12	QJ168QDJ.03-06C	Valve, Intake	1
13	QJ168QDL.03-01	Stud, Connecting	2
14	QJ168QDL.03.01B	Camshaft	1
15	QJ1P64.02.01	Seal, Valve Stem	1

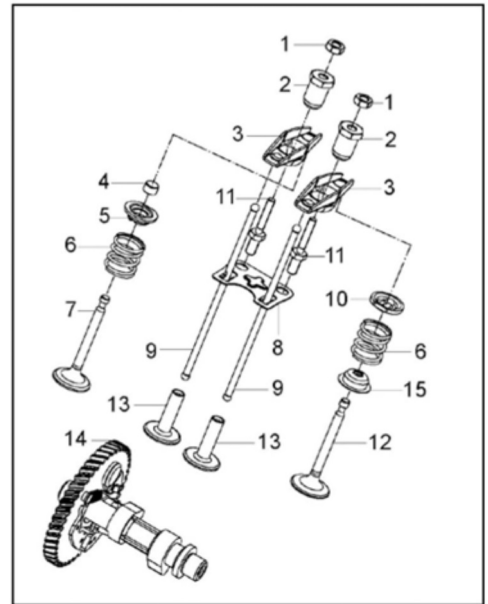

## CRANKSHAFT ASSEMBLY

NO.	PART NO.	DESCRIPTION	QTY
1	GB/T6177.2-2000	Nut, M14*1.5	1
2	QJ168QDJ.04-10	Start-Up Ratchet Gear	1
3	QJ168QDJ.04-11	Fan Wheel	1
4	QJ168QDJ.04.03	Fly Wheel	1
5	JF170FLH.04.02H	Crankshaft	1
6	QJ168QDJ.04-05	Clip, Piston Pin	2
7	JF170FLH.04-01B	Piston	1
8	QJ168QDJ.04-04	Pin, Piston	1
9	JF170FLH.04.01B	Piston Ring Assembly	1
10	QJ168QDJ.04.02	Connecting Rod Assembly	1

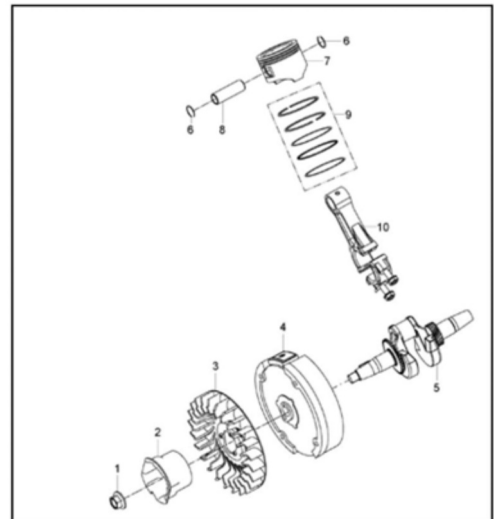

### CENTRIFUGAL ADJUSTMENT (GOVERNOR)

NO.	PART NO.	DESCRIPTION	QTY
1	QJ168QDJ.05-01	Arm	1
2	QJ168QDJ.05-07	Rod, Tension	1
3	QJ168QDJ.05-06	Spring 2, Tension	1
4	GB/T6177.1-2000	Nut	1
5	QJ182QDP.06-03	Bolt, Square	1
6	QJ168QDJ.05-09	Spacer 2	1
7	QJ182QDP.06-02	Hair Pin	1
8	QJ168QDJ.05-03	Governor Crank	1
9	QJ168QDJ.05-08	Spacer 3	1
10	QJ168QDJ.05-04	Pin	1
11	QJ166QDK.01-02	Circlip	1
12	QJ168QDJ.05.02	Centrifugal Timing Implement	1
12.1	QJ168QDJ.05.02-01	Body, Centrifugal Governer	1
12.2	QJ168QDJ.05.02-03	Pawl	2
12.3	QJ168QDJ.05.02-02	Pin	2
13	QJ168QDJ.05-08	Spacer 3	1
14	QJ168QDJ.05-02	Cover, Push Rod	1
15	QJ168QDJ-2.02-01	Spring 1, Tension	1
16	GB/T5789-1986	Bolt	2
17	QJ168QDJ-2.02.01	RPM Adj Mechanism	1

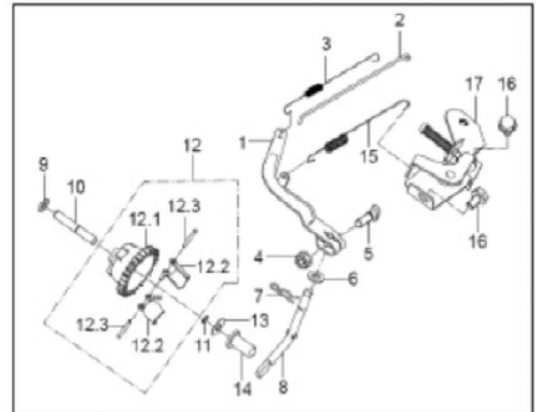

### IGNITION SYSTEM

NO.	PART NO.	DESCRIPTION	QTY
1	QJ168QDJ.11.03B	Ignition Coil	1
2	GB/T5789-1986	Bolt M6x25	2
3	QJ168QDJ.11.02	Connecting Wire Assy	1
4	QJ182QDP.01.05	Electronic Switch	1
5	GB/T5789-1986	Bolt M6X10	1

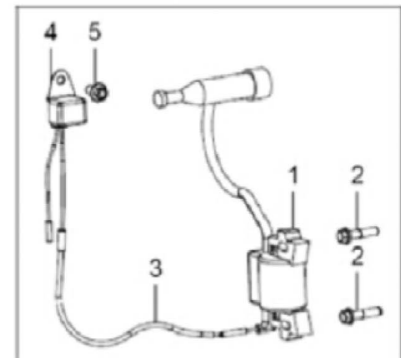

## CARBURETOR

NO.	PART NO.	DESCRIPTION	QTY
1	QJ168FLH-4.04.01	Carburator Assembly	1
2	JF168FJH-15.05-08	Clamp, Fuel Line,	2
3	QJ168QDJ.10.03-01	Hose, Fuel	1

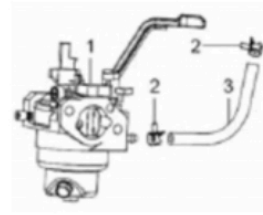

## PLATE VENTILATION HOOD COMPONENTS

NO.	PART NO.	DESCRIPTION	QTY
1	JF168FJH-M.06.01D	Starter Assembly	1
1.1	JF168FLH-M.06.01-06	Screw	1
1.2	JF168FLH-M.06.01-08	Guide Pan	1
1.3	JF168FLH-M.06.01-07	Ratchet	2
1.4	JF168FLH-M.06.01-05	Return Spring	2
1.5	JF168FLH-M.06.01-04	Spring	1
1.6	JF168FLH-M.06.01-03	Gasket	1
1.7	JF168FLH-M.06.01-02	Spool	1
1.8	JF168FLH-M.06.01-01	Wind Spring	1
1.9	JF168FLH-M.06.01.01	Starter Cover	1
1.10	QJ168QDJ.06-08B	Starter Rope	1
1.11	JF168FJH.06.01.02C	Handle, Recoil Starter	1
2	GB/T5789-1986	Bolt M6x8	3
3	QJ168QDJ.06.02.02B	Engine Side Cover Assy.	1
4	GB/T5789-1986	Bolt M6x10	6
5	QJ168QDJ.06.02.01	Shield 1	1
6	GB/T5789-1986	Bolt M6x20	1
7	QJ168QDJ.06.02-01	Shield 2	1
8	QJ168QDJ.06.02.01-03	Stem	1

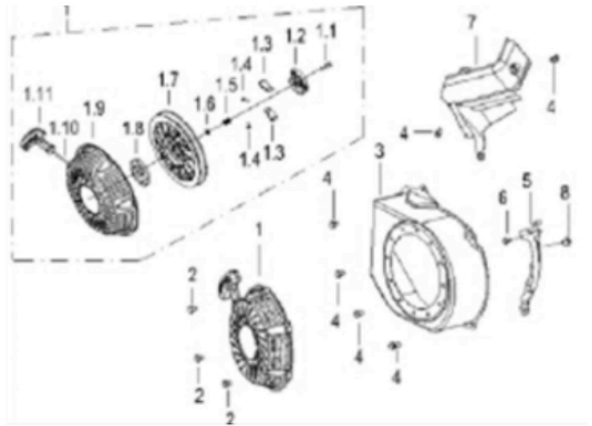

## AIR CLEANER

NO.	PART NO.	DESCRIPTION	QTY
1	JF170FLH-2.07.01E	Air Filter Assembly	1
1.1	JF170FLH-2.07.01E-01	Bolt	1
1.2	JF156FFH.10-01C	Air Filter Cover	1
1.3	JF170FLH-2.07.01E-02	Air Cleaner Element	1
1.4	JF170FLH-2.07.01E-03	Air Cleaner Case	1
1.5	JF170FLH-2.07.01E-04	Support Plate	1
2	JF170FLH.07-01	Seal Spacer	1
3	QJ168QDJ.07-01C	Breather Tube	1
4	37530121001000	Hose $\phi 5 \times \phi 8$	1
5	JF1P64FJV-S.14-05	Clamp $\phi 7$	1
6	JF168FJH-15.05-08	Clamp $\phi 8$	1

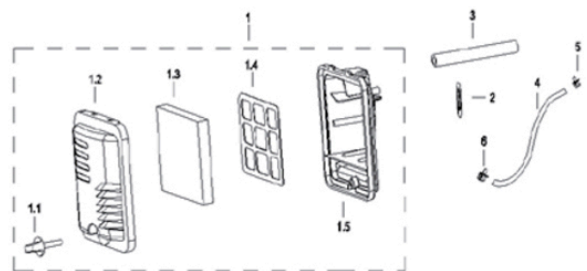

## GAS TANK ASSEMBLY

NO.	PART NO.	DESCRIPTION	QTY
1	KE3500D.01.01B	Fuel Tank Comp	1
2	QJ2600.01-04A	Filtering Net	1
3	QJ2600.01.05	Sump Cover Subassembly	1
4	QJ2900.08.02A	Overflow Valve	1
5	GB/T5789-1986	Bolt M6x20	4
6	GB/T96.2-2002	Washer φ6	4
7	QJ2600.01-02	Fuel Tank Rubber Hose	4
8	QJ2600.01-01	Fuel Tank Rubber	4
9	QJ2600.01.02	Fuel Petcock	1

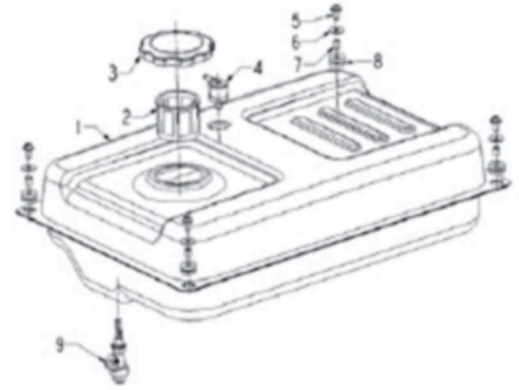

## PANEL

NO.	PARTS NO.	DESCRIPTION	QTY
1	FG3000NCX.02.01D	Panel	1
2	GB/T5789-1986	Bolt M6*10	4
3	QJ1200.02.04	Engine Switch	1
4	QJ1500.02.06	T- Socket	1
5	QJ2600.02.05B	Voltmeter	1
6	GB/T6170-2015	Nut M6	2
7	GB/T923-2009	Nut M6	1
8	GB/T818-2000	Screw M4*12	6
9	KE4500E.02.03B	RV-Socket	1
10	QJ3200.01.04	Socket of USA Standard	2
11	GB/T5789-1986	Bolt M6*16	1
12	QJ2500.03-04	Rectifier KBPC2506	1
13	QJ6500.02.06	DC Protector 8A	1
14	GB/T818-2000	Screw M4*16	1
15	GB/T2672-2017	Screw M4*16	2
16	CZ4350.02.04	CO Module	1
17	GB/T6177.1-2000	Nut M4	8
18	QJ2900.01.04	AC Protector 20A	1
19	KE3500.02-01	Bottom Shell	1
20	GB/T95-2002	Washer φ4	4
21	QJ1200.02-02A	Jacket	1
22	QJ6000.02-02	Sheath	1
23	FG3000NCX.02.02D	Cable	1
24	GEN4000.02.03	CO Module Cable	1

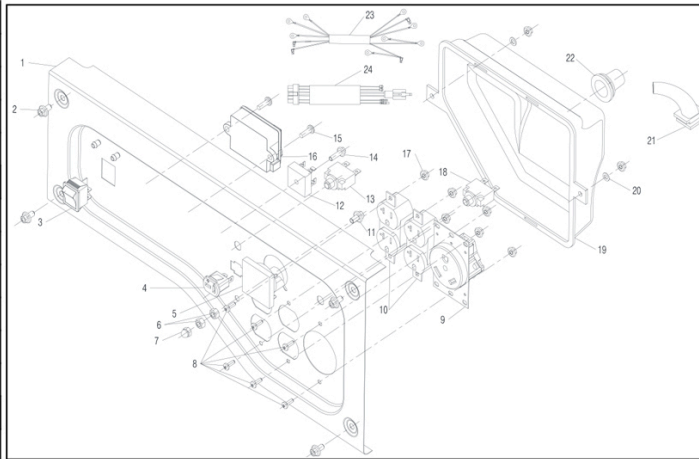

## MUFFLER

NO.	PARTS NO.	DESCRIPTION	QTY
1	QJ3500.05.01	Muffler	1
2	GB/T6177.1-2000	Nut M8	3
3	QJ2500.05-01	Muffler Gasket	1
4	GB/T5789-1986	Bolt M8*35	1

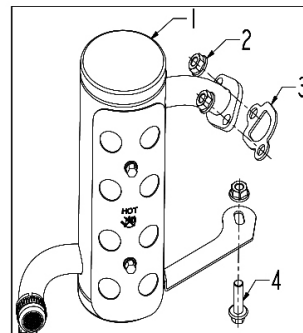

## GENERATOR

NO.	PARTS NO.	DESCRIPTION	QTY
1	QJ3200.03.02	Rotor Assy	1
2	QJ3200.03.01	Stator Assy	1
3	QJ3200.01-01A	Alternator Cover	1
4	QJ2500.03-01	Motor Casing (End Cap)	1
5	GB/T5789-1986	Bolt M5*8	3
6	QJ2300.03.03	Brush Module	1
7	GB/T5780-2000	Bolt M5*20	2
8	QJ6000.03-03	Connecting Block	1
9	GB/T5789-1986	Bolt M5*12	4
10	GB/T6170 -2000	Flat Washer $\phi 5$	4
11	GB/T93-1987	Spring Washer $\phi 5$	4
12	GB/T6170 -2000	Nut M5	4
13	QJ2500.03-02	Right Side Cover	1
14	GB5789-1986	Bolt M6*150	4
15	QJ2300.03.04	AVR	1
16	GB/T5780-2000	Bolt M8*230	1

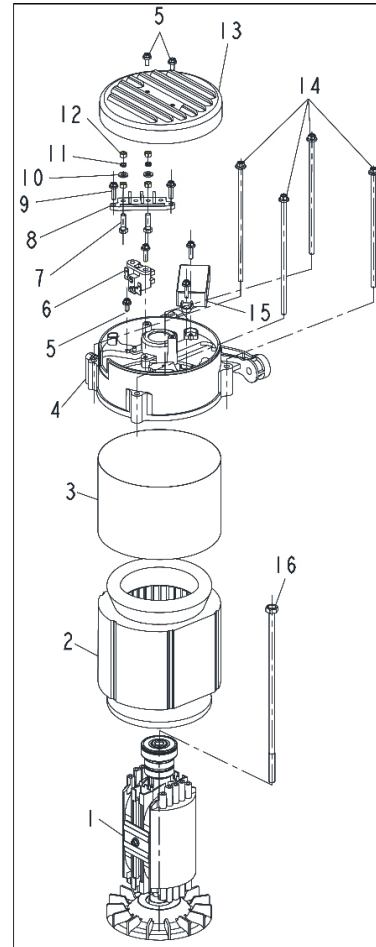

## FRAME

NO.	PARTS NO.	DESCRIPTION	QTY
1	GEN4000.06.01	Frame Welding Components	1
2	GB5789-1986	Bolt M6*150	4
3	KE3500D.06-01	Fuel Tank Protecting Plate	1
4	GB/T6177.1-2000	Nut M8	9
5	ACG4-2000.06.03	Cushioning	1
6	QJ2500.06.03	Right Shockproof Mounting Feet	2
7	QJ2600.08.02	Left & Right Shockproof Mounting Feet	2
8	KE3500D.06.02	Rail Wedded Components	1

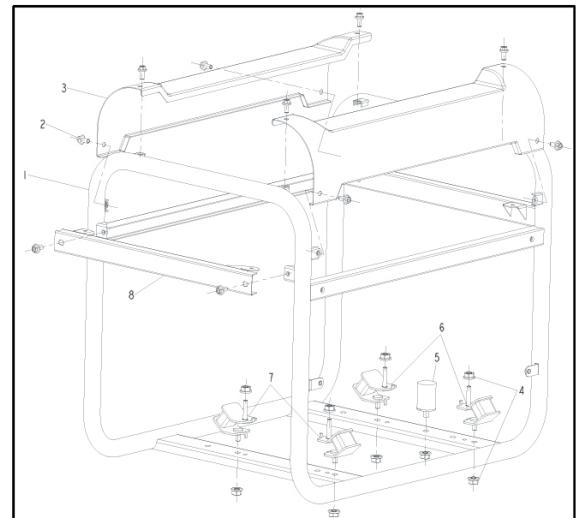

## EMISSION CONTROL SYSTEM WARRANTY

Buffalo Corporation

### Your Warranty Rights and Obligations

The United States Environmental Protection Agency (US EPA) and Buffalo Corp. are pleased to explain the exhaust and evaporative emissions control system warranty on your 2021-2022 model year small off-road engine. Buffalo Corp. must warrant the emissions control system on your small off-road engine for the periods of time listed below provided there has been no abuse, neglect or improper maintenance of your small off-road engine or equipment leading to the failure of the emissions control system.

Your emissions control system may include parts such as the carburetor or fuel-injection system, the ignition system, catalytic converter, fuel tanks, fuel lines (for liquid fuel and fuel vapors), fuel caps, valves, canisters, filters, clamps and other associated components. Also included may be hoses, belts, connectors, and other emission-related assemblies. Where a warrantable condition exists, Buffalo Corp. will repair your small off-road engine at no cost to you including diagnosis, parts and labor.

### Manufacturer's Warranty Coverage

The exhaust and evaporative emissions control system on your small off-road engine is warranted for two years. If any emissions-related part on your small off-road engine is defective, the part will be repaired or replaced by Buffalo Corp.

### Owner's Warranty Responsibility

As the small off-road engine owner, you are responsible for the performance of the required maintenance listed in your owner's manual. Buffalo Corp. recommends that you retain all receipts covering maintenance on your small off-road engine, but Buffalo Corp. cannot deny warranty coverage solely for the lack of receipts or for your failure to ensure the performance of all scheduled maintenance.

As the small off-road engine owner, you should however be aware that Buffalo Corp. may deny you warranty coverage if your small off-road engine or a part has failed due to abuse, neglect, or improper maintenance or unapproved modifications.

You are responsible for presenting your small off-road engine to a Buffalo Corp. distribution center or service center as soon as the problem exists. The warranty repairs shall be completed in a reasonable amount of time, not to exceed 30 days.

If you have any questions regarding your warranty rights and responsibilities, you should contact Buffalo Corp. customer service representative at 1-866-460-9436 or write to [info@buffalotools.com](mailto:info@buffalotools.com) or [cs@buffalotools.com](mailto:cs@buffalotools.com).

### DEFECTS WARRANTY COVERAGE

Adopted by the EPA, Buffalo Corp. warrants to the ultimate purchaser and each subsequent purchaser that the small off-road engine (SORE)(1) has been designed, built and equipped so as to conform with all applicable regulations; and (2) is free from defects in materials and workmanship that cause the failure of a warranted part to conform with those regulations as may be applicable to the terms and conditions stated below.

(a) The warranty period begins on the date the engine is delivered to an ultimate purchaser or first placed into service. The warranty period is two years.

(b) Subject to certain conditions and exclusions as stated below, the warranty on emissions related parts is as follows:

(1) Any warranted part that is not scheduled for replacement as required maintenance in your Owner's Manual is warranted for the warranty period stated above. If the part fails during the period of warranty coverage, the part will be repaired or replaced by Buffalo Corp. according to Subsection (4) below. Any such part repaired or replaced under warranty will be warranted for the remainder of the periods.

(2) Any warranted part that is scheduled only for regular inspection in your owner's manual is warranted for the warranty period stated above. Any such part repaired or replaced under warranty will be warranted for the remaining warranty period.

(3) Any warranted part that is scheduled for replacement as required maintenance in your owner's manual is warranted for the period of time before the first scheduled replacement date for that part. If the part fails before the first scheduled replacement, the part will be repaired or replaced by Buffalo Corp. according to Subsection (4) below. Any such part repaired or replaced under warranty will be warranted for the remainder of the period prior to the first scheduled replacement point for the part.

- (4) Repair or replacement of any warranted part under the warranty provisions herein must be performed at a warranty station at no charge to the owner.
- (5) Notwithstanding the provisions herein, warranty services or repair will be provided at all of our distribution centers that are franchised to service the subject engines.
- (6) The engine owner must not be charged for diagnostic labor that leads to the determination that a warranted part is in fact defective, provided that such diagnostic work is performed at a warranty station.
- (7) Buffalo Corp. is liable for damages to other engine components proximately caused by a failure under warranty of any warranted part.
- (8) Throughout the engine warranty period stated above, Buffalo Corp. will maintain a supply of warranted part sufficient to meet the expected demand for such parts.
- (9) Any replacement may be used in the performance of any warranty maintenance or repairs and must be provided without charge to the owner. Such use will not reduce the warranty obligations of Buffalo Corp.
- (10) Add-on or modified parts that are not exempted by the EPA may not be used. The use of any non-exempted add-on or modified parts by the ultimate purchaser will be grounds for disallowing a warranty claims. Buffalo Corp. will not be liable to warrant failures of warranted parts caused by the use of a non-exempted add-on or modified part.
- (11) The manufacturer issuing the warranty shall provide any documents that describe that manufacturer's warranty procedures or policies within five working days of request by EPA.

#### **EMISSION WARRANTY PARTS LIST**





- (1) Fuel Metering System:
  - (a) Gasoline carburetor assembly and its internal components
  - (b) Carburetor gaskets (c) fuel lines (for liquid fuel and fuel vapors) (d) Clamps
  - (e) Fuel tank (f) Fuel line fittings (g) Pressure regulator(if equipped)
  - (h) Mixer assembly and its internal components (if equipped)
- (2) Air induction system including:
  - (a) Intake pipe/manifold (b) Air cleaner
- (3) Ignition system including:
  - (a) Spark plug (b) Ignition coil
- (4) Catalytic muffler assembly including:
  - (a) Muffler gasket (b) Exhaust manifold (c) Catalytic converter
- (5) Crankcase breather assembly including:
  - (a) Breather connection tube
- (6) Fuel tank evaporative emissions control system including:
  - (a) Purge valves (b) Fuel cap (c) Fuel tank (d) fuel lines (for liquid fuel and fuel vapors)
- (7) Miscellaneous items used in above systems including:
  - (a) Switches (b) Hoses, belts connectors and assemblies
- (8) Air injection system
  - (a) Pulse valve

#### **Please Note:**

For this warranty, Buffalo Corp. shall warrant the Evaporative and Exhaust combined emission control system on your products.

## Carbon Monoxide (CO) Detection and Shut-off System

This generator features CO WARNING, which will automatically shut-off if dangerous levels of CO is detected.

<b>FEATURES</b>  <b>ALERT!</b>	Carbon monoxide (also known as CO) can be dangerous for humans and pets. Carbon monoxide poisoning can lead to death in a very short time. It is called "the silent killer" because it is odorless, tasteless and invisible: you may be exposed without knowing it. This generator features CO WARNING, which will automatically shut-off if dangerous levels of CO is detected.	<b>⚠ WARNING! IF DANGEROUS CARBON MONOXIDE LEVELS ARE DETECTED, ENGINE WILL SHUTOFF</b>  <b>AUTOMATIC SHUTOFF - YOU MUST:</b> MOVE GENERATOR TO AN OPEN, OUTDOOR AREA. POINT EXHAUST AWAY. DON'T RUN GENERATOR IN ENCLOSED AREAS (E.G. NOT IN HOUSE OR GARAGE)	 The indicator will light RED and the engine will shutdown if dangerous CO levels are detected. The engine will not restart for 5 minutes. If an error in the carbon monoxide system is detected, the indicator will light YELLOW.  <b>MOVE TO FRESH AIR AND GET MEDICAL HELP IF SICK, DIZZY OR WEAK.</b>
---	---	---	--

Carbon monoxide (also known as CO) can be dangerous for humans and pets. Carbon monoxide poisoning can lead to death in a very short time. It is called "the silent killer" because it is odorless, tasteless and invisible: you may be exposed without knowing it.

The CO Detection module monitors for the accumulation of poisonous CO gas found in engine exhaust when the generator is running. If CO detector detects increasing levels of CO gas, it automatically shuts off the engine. CO detector only monitors when the engine is running. Generators are intended to be used outdoors, far from occupied buildings and the exhaust pointed away from personnel and buildings. However, if misused and operated in a location that results in the accumulation of CO, like indoors or in a partially enclosed area, CO detector shuts off the engine, notifies the user of what has happened and directs the user to read the instruction action label for steps to take. **CO detector is not a substitute for an indoor carbon monoxide alarm.**

After a shut-off, a blinking RED light in the CO detector badge on the side of the generator provides notification that the generator was shut off due to an accumulating CO hazard. The RED light will blink for at least five minutes after a CO shut-off. Move the generator to an open, outdoor area and point the exhaust away from people and occupied buildings. Once relocated to a safe area, the generator can be restarted and the proper electrical connections made to supply electrical power. The RED light will stop blinking automatically upon engine re-start. Introduce fresh air and ventilate the location where the generator had shut down.

If a CO detector system fault has occurred and no longer provides protection, the portable generator is shut off automatically and the YELLOW light will blink for at least five minutes in the CO detector badge to notify the user of the fault. The CO detector module can only be diagnosed and repaired by a trained technician at the dealer. The generator can be re-started, but may continue to shut-off.

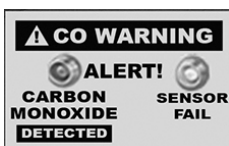

CO detector will detect the accumulation of Carbon Monoxide from other fuel burning sources such as engine powered tools or propane heaters used in the area of operation. For example, if another generator is used and the exhaust is pointed at a CO detector equipped generator, CO detector may initiate a shut-off due to rising CO levels. This is not an error. Hazardous Carbon Monoxide has been detected. The user must take action to move and re-direct these devices to better dissipate Carbon Monoxide far away from personnel and occupied buildings.

202109