

Please read instructions carefully before use. Retain for future reference

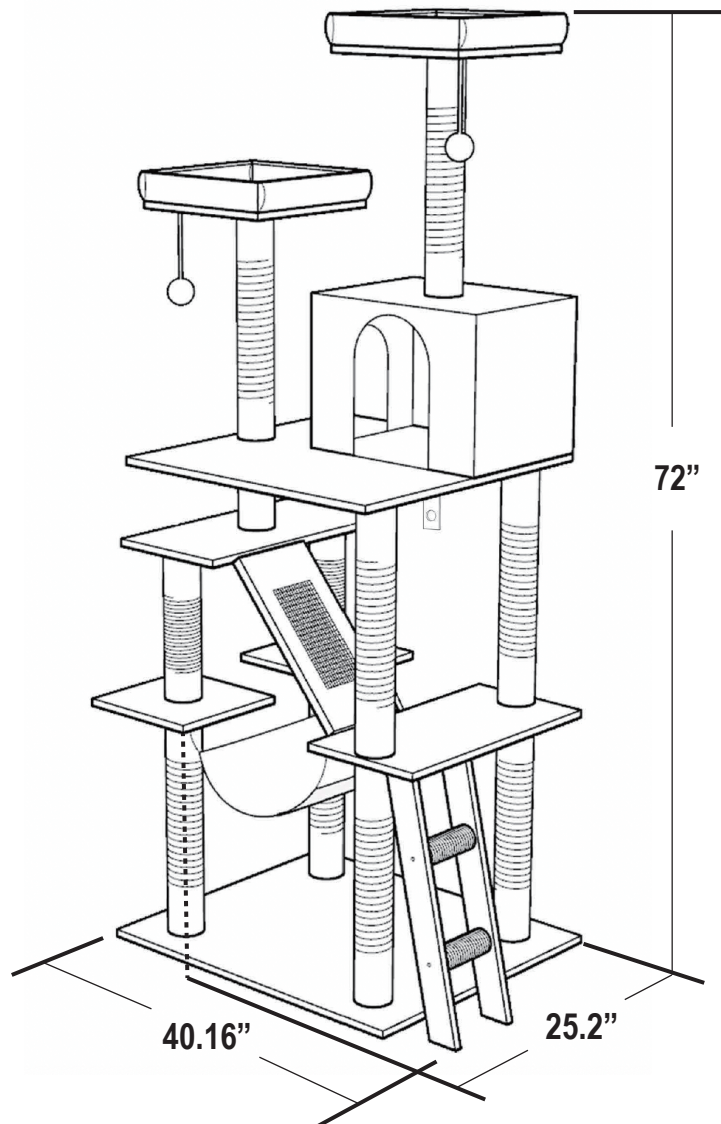

Assembled Dimensions

40.16 IN. W X 25.2 IN . D X 72IN. H
 102CM W X 64CM D X 183CM H



Distributed by:
 TRACTOR SUPPLY COMPANY
 5401 VIRGINIA WAY,
 BRENTWOOD TN 37027
 For customer support,
 call: 1-888-376-9601
www.TractorSupply.com
 MADE IN CHINA

Approximate assembly time: 30 Minutes	People for assembly: 	Required assembly space: Floor area 10ft. x 5ft. (3m x 1.5m)	
--	--	---	---

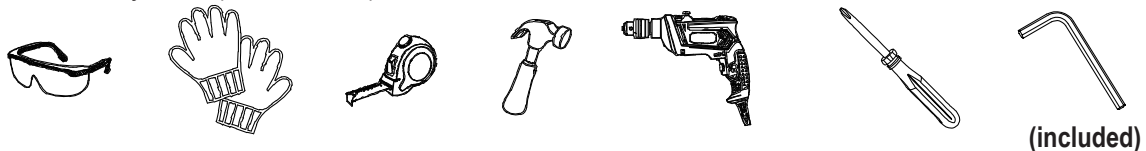



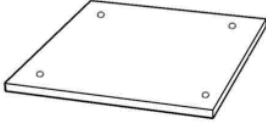
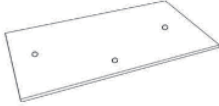
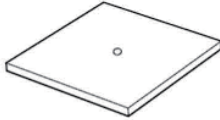
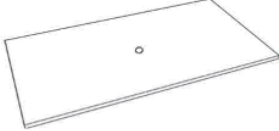
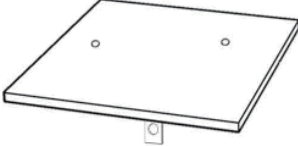
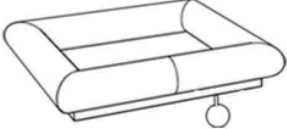



Required assembly tools (not included):









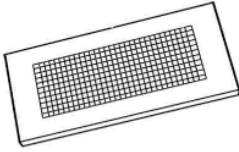
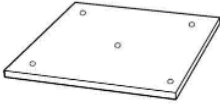
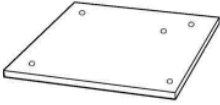
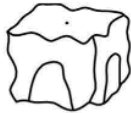

PARTS LIST

Part#	Description	Drawing	Qty.
1	Bottom plate		1
2	Lying plate,right		1
3	Lying plate,left		2
4	Lying plate,left		1
5	Lying plate,top		1
6	Square bed with a ball		2
7	Staircase,left		1
8	Staircase,right		1

PARTS LIST

Part#	Description	Drawing	Qty.
9	Hammock		1
10	Post,10.6" (27cm)		4
11	Post,18.5" (47cm)		5
12	Post with spacer,11.4" (29cm)		2
13	Post with spacer,18.5" (47cm)		1
14	Post with spacer,17.7" (45cm)		2
15	Post,5.9" (15cm)		2
16	Post,6.5" (16.7cm)		1

PARTS LIST

Part#	Description	Drawing	Qty.
17	Scratching board 14.5" (37cm)length		1
18	Top board of square cave		1
19	Bottom board of square cave		1
20	Square cave cover		1
21	Flathead screw,M10*40mm		6+1
22	Thread rod,M10*85mm		5+1
23	Flathead screw,M8*16mm		5+1
24	Flathead screw,M10*70mm		1
25	Flathead screw,M8*40mm		12+1
26	Tapping screw,M4*48mm		1
27	Wall anchor		1
28	Allen key		1

TIP BEFORE YOU START

- * Ensure that all parts are present prior to assembly.
- * Check all packing material carefully before discarding, as some parts may be encased in the packing material.
- * For ease and speed of assembly, it is recommended that prior to each step all required parts are identified.
- * Ensure that you have sufficient space and people (as indicated on page 1) to assemble product safely.
- * During assembly take care not to over-tighten any fittings, as this may damage the product.

CARE AND MAINTENANCE

- * Always inspect the product during each use for any obstructions.
- * The manufacturer will not accept responsibility for unauthorized repairs or modifications to this product.
- * To prolong the life of your cat furniture we recommend storage in a dry area when not in use or during austere weather conditions.

WEIGHT LIMIT

Max Weight 67.5 LBS., 22.5 LBS. for each cushion and hammock
(Max Weight 30.62 KG, 10.21 KG for each cushion and hammock)

Step 1

- Assemble the staircases(#7 & #8) and posts(#15) through flathead screw (#25).

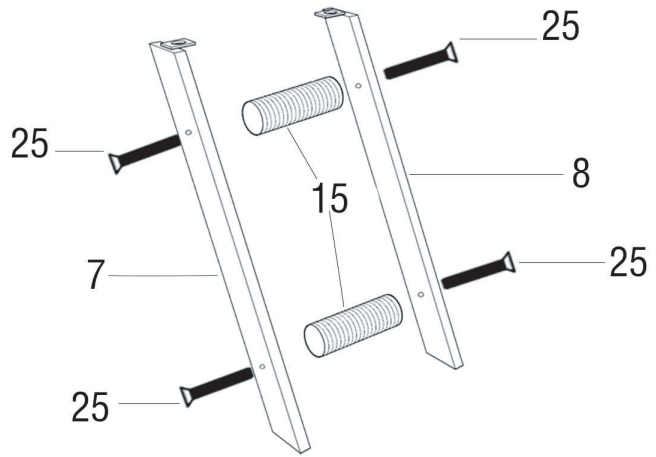

- Assemble the boards(#18 & #19) with posts(#10) and square cover(#20)with flathead screw (#25) make sure the edge of cover is well under bottom board(#19).

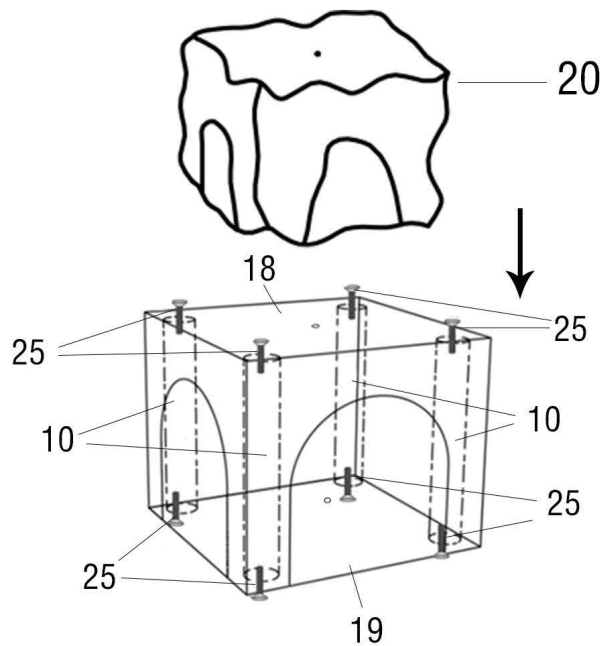

Step 2

- Connect the top bed(#6) and the cat cave by a post(#14) and flathead screw(#21).

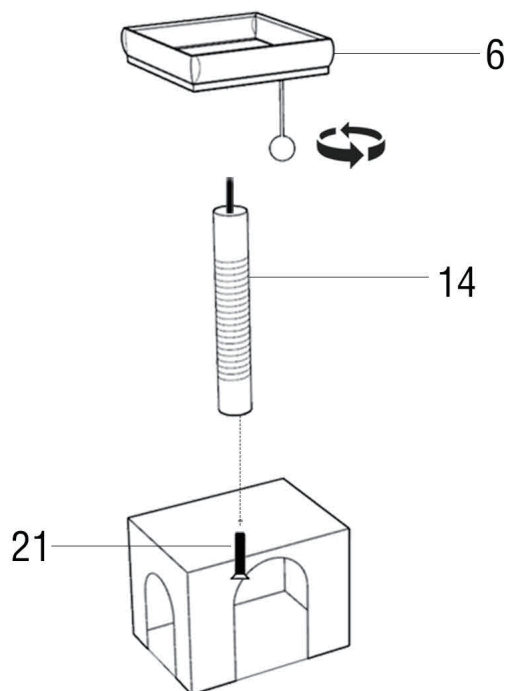

Step 3

- Rotate a post(#14) into the top bed(#6).

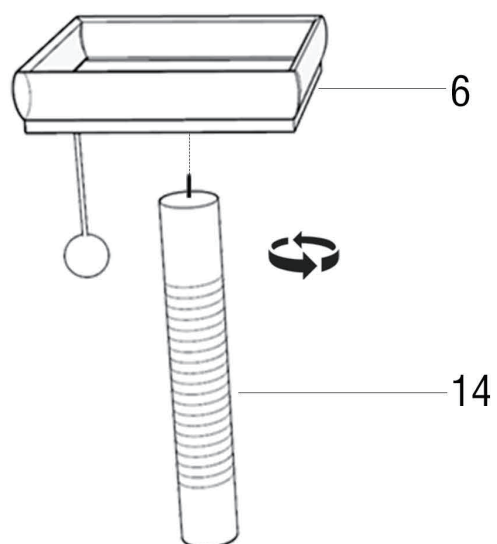

Step 4

- Use flathead screws(#24) to link the lying plate(#5), cat cave and post(#11)together, then use screws(#22) to link the top socket and post(#16) together, and finally rotate the post(#13) into the lying plate(#5).

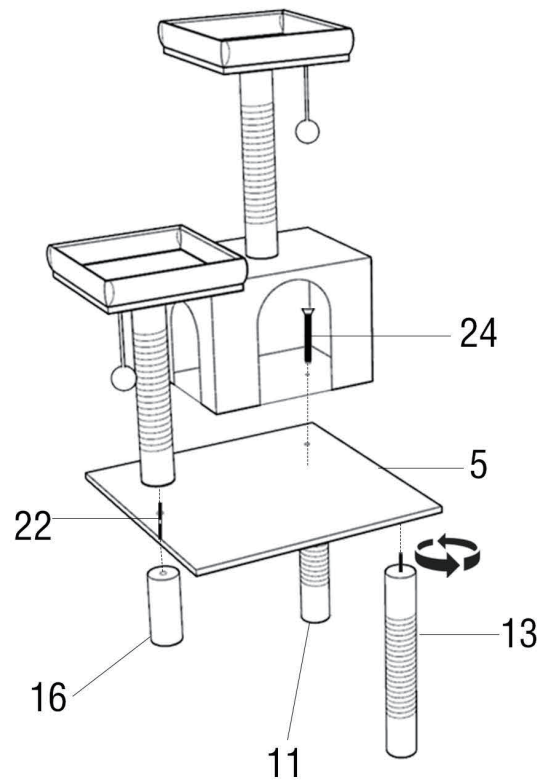

Step 5

- The plate(#2) and the post(#11)are assembled by screws(#22),the plate(#4)is assembled with screws(#21), and the rotated post(#12) into the plate(#4).

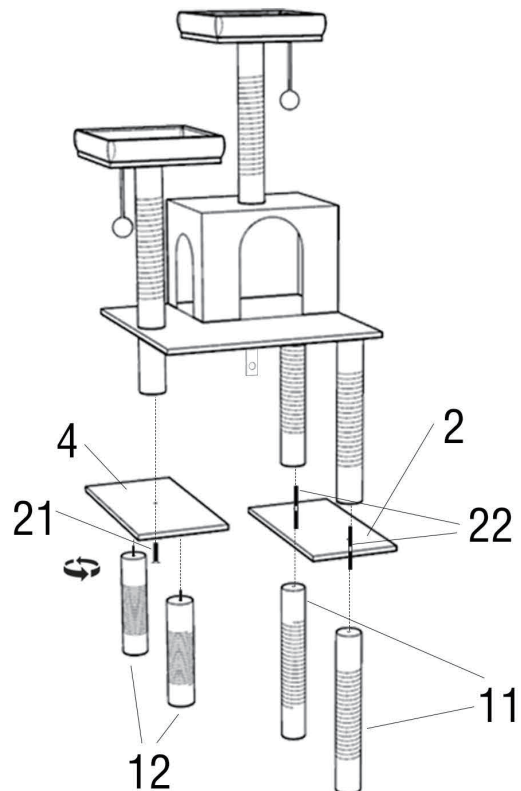

Step 6

- Assemble the scratching board (#17) with screws(#23), and then assemble the plates(#3) and posts(#11) with screws(#22).

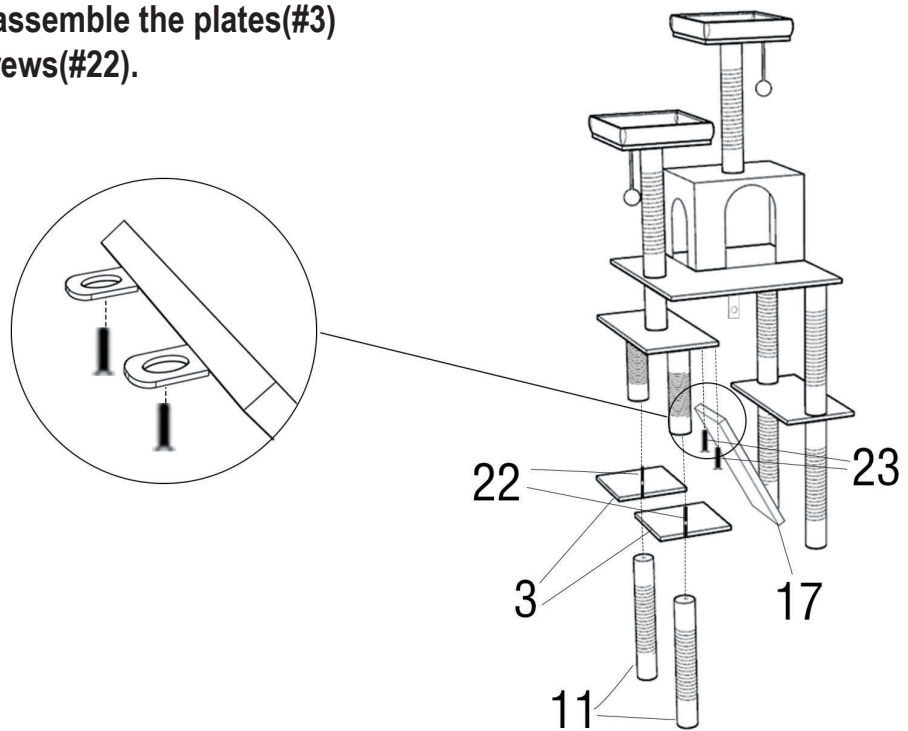

Step 7

- Assemble the bottom of the scratching board(#17) by screws(#23).assemble the hammock(#9) and assemble the bottom plate(#1) with screws(#21).

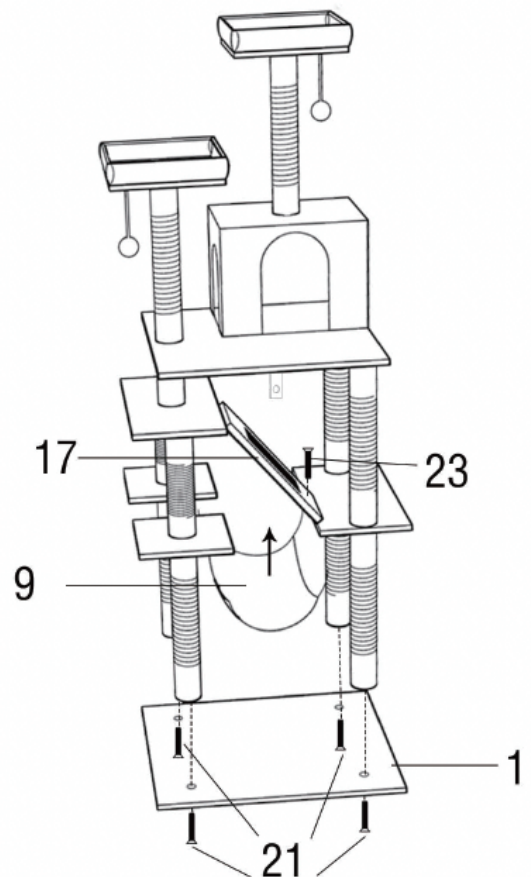

Step 8

- Fix the assembled staircase to the board(#2) with screws(#23).

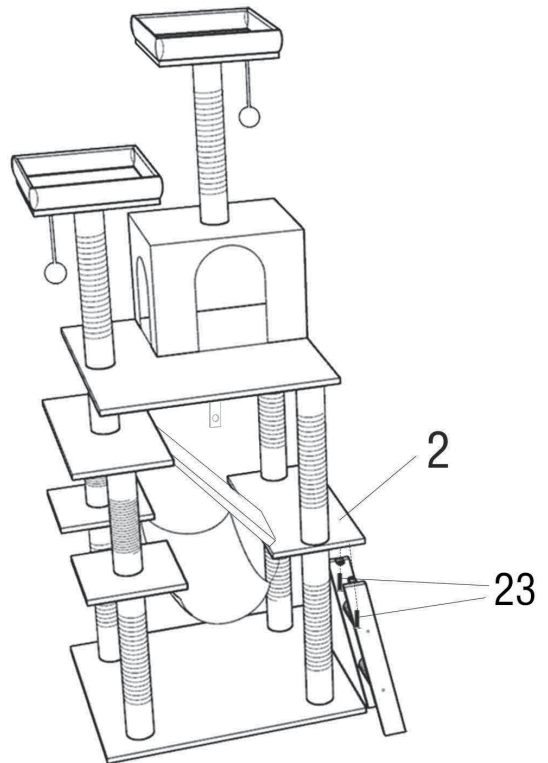

Step 9

- Attach this product to the wall with anchor(#27) and tapping rod(#26).

