

# TOMAHAWK

**TMOP18e  
Mini Floor Scrubber**

**Operations Manual**



# Table of Contents

<b>1. Safety Information</b>	<b>4</b>
- Fire Safety	5
- Operating Safety	5
- Service Safety	6
<b>2. PRODUCT DATA</b>	<b>6</b>
- Specifications	6
- Features	7
- Handle Features	7
<b>3. INTENDED USE OF THE EQUIPMENT</b>	<b>8</b>
- Non Intended Use of the Equipment	8
<b>4. OPERATION</b>	<b>9</b>
- Filling the Cleaning Solution Tank	9
- Operating the Equipment	9
- Modes	9
- Stopping the Equipment	10
<b>5. CLEANING &amp; STORAGE</b>	<b>10</b>
- Cleaning	10
- Storage	11
<b>6. MAINTENANCE</b>	<b>11</b>
- Brush Replacement	11
- Squeegee Replacement	11
- Attaching a New Squeegee	12
- Replacing the Hose	12
- Maintenance Record	13
<b>7. TROUBLESHOOTING</b>	<b>14</b>
<b>8. REPLACEMENT PARTS</b>	<b>15</b>
<b>9. WARRANTY</b>	<b>15</b>
- Warranty Claims	15
<b>10. CATALOG &amp; COUPON</b>	<b>18</b>

# Register Your Equipment

Thank you for purchasing TOMAHAWK® equipment! Your product is covered by the TOMAHAWK® Warranty policy, but in order to activate your warranty, we need you to register your product. In addition to activating your equipment warranty, product registration will grant you access to important product updates, streamlined customer service and more.

## INCLUDED WITH YOUR REGISTRATION

- ✓ Equipment Warranty Activation
- ✓ Product Updates
- ✓ Streamlined Customer Service
- ✓ Exclusive Discounts and Sales

## STEPS TO REGISTER YOUR EQUIPMENT

1. Visit [www.tomahawk-power.com](http://www.tomahawk-power.com)
2. Choose “Product Registration” at the bottom of the page
3. Enter your equipment’s serial number to get started
4. Provide all required information
5. Submit Registration



---

# Equipment Resources

TOMAHAWK® Customer Service doesn’t stop at checkout. We understand to keep a job-site running smoothly - the proper equipment, spare parts, instruction manuals, and more are needed at the drop of a hat. Visit [www.tomahawk-power.com](http://www.tomahawk-power.com) to gain access to the incredible resources below.

## How To Video Library

More of a visual person? Visit our Video Library for equipment assembly instructions, troubleshooting tips, and more!

**Found at the TOMAHAWK® Resource Center**

## Manual and Assembly Guide Library

Visit our Manual Library if you are looking for a lost operations manual or a particular spare part?

**Found on the TOMAHAWK® Manuals Page**

## Service Requests

In need of a quick fix or a service center referral? Submit a Service Request and a TOMAHAWK® Technician will respond shortly to get you the help you need.

**Choose “Service Request” at the bottom of [www.tomahawk-power.com](http://www.tomahawk-power.com)**



This manual provides information and procedures to safely operate and maintain this model. For your own safety and protection from injury, carefully read, understand and observe the safety instructions described in this manual.

Keep this manual or a copy of it with the machine. If you lose this manual or need an additional copy, please contact TOMAHAWK® or visit [www.tomahawk-power.com](http://www.tomahawk-power.com) This machine is built with user safety in mind; however, it can present hazards if improperly operated and serviced. Follow operating instructions carefully. If you have questions about operating or servicing this equipment, please contact TOMAHAWK®.

The information contained in this manual is based on machines in production at the time of publication. TOMAHAWK® reserves the right to change any portion of this information without notice.

No part of this publication may be reproduced in any form or by any means, electronic or mechanical, including photocopying, without express written permission from TOMAHAWK®.

Any type of reproduction or distribution not authorized by TOMAHAWK® represents an infringement of valid copyrights and will be prosecuted. We expressly reserve the right to make technical modifications, even without due notice, which aim at improving our machines or their safety standards.

## 1. Safety Information

This manual contains DANGER, WARNING, CAUTION, and NOTE callouts which must be followed to reduce the possibility of personal injury, damage to the equipment, or improper service.



This is the safety alert symbol. It is used to alert you to potential personal injury hazards. Obey all safety messages that follow this symbol to avoid possible injury or death.



**DANGER** indicates an imminently hazardous situation which, if not avoided, will result in death or serious injury.



**WARNING** indicates a potentially hazardous situation which, if not avoided, could result in death or serious injury.



**CAUTION** indicates a potentially hazardous situation which, if not avoided, may result in minor or moderate injury.

## 1.1 Fire Safety

If your machine catches fire, turn off the electric supply. Using a dry powder or CO2 fire extinguisher, put out the fire. If the fire cannot be put out, keep away and call the fire department. If you are in any doubt about the safety condition of your machine, please consult TOMAHAWK®.

## 1.2 Operating Safety



Familiarity and proper training are required for the safe operation of equipment!

Equipment operated improperly or by untrained personnel can be dangerous! Read the operating instructions contained in both this manual and the engine manual and familiarize yourself with the location and proper use of all controls. Inexperienced operators should receive instruction from someone familiar with the equipment before being allowed to operate the machine.

**1.2.1 NEVER** allow anyone to operate this equipment without proper training. People operating this equipment must be familiar with the risks and hazards associated with it.

**1.2.2 NEVER** use accessories or attachments for this equipment, which are not recommended by TOMAHAWK®. Damage to the equipment and/or injury to user may occur.

**1.2.3 NEVER** leave machine running unattended.

**1.2.4 ALWAYS** be sure operator is familiar with proper safety precautions and operation techniques before using machine.

**1.2.5 ALWAYS** wear hearing protection when operating equipment.

**1.2.6 ALWAYS** wear protective clothing appropriate to the job site when operating equipment.

**1.2.7 ALWAYS** wear hearing protection when operating equipment.

**1.2.8 ALWAYS** store equipment properly when it is not being used. Equipment should be stored in a clean, dry location out of the reach of children.

**1.2.9 ALWAYS** operate machine with all safety devices and guards in place and in working order. **DO NOT** modify or remove safety devices. **DO NOT** operate machine if any safety devices or guards are missing or inoperative.

**1.2.10 ALWAYS** read, understand, and follow procedures in Operator's Manual before attempting to operate equipment.

## 1.3 Service Safety



WARNING

For your own personal protection and for the safety of those around you, please read and ensure you fully understand the following safety information. It is the responsibility of the operator to ensure that he/she fully understands how to operate this equipment safely. If you are unsure about the safe and correct use of this equipment consult your supervisor.

**1.3.1 DO NOT** attempt to clean or service machine while it is running. Rotating parts can cause severe injury.

**1.3.2 ALWAYS** replace worn or damaged components with spare parts designed and recommended by TOMAHAWK®.

**1.3.3 ALWAYS** keep machine clean and labels legible. Replace all missing and hard-to-read labels. Labels provide important operating instructions and warn of dangers and hazards.

**1.3.4** Cordon off the work area and keep members of the public and unauthorized personnel at a safe distance.

**1.3.5** Personal Protective Equipment (PPE) must be worn by the operator whenever this equipment is being used.

**1.3.6** Make sure you know how to safely switch this machine OFF before you switch it ON in case you get into difficulty.

**1.3.7** Always switch OFF before transporting, moving it around the site, or servicing it.

**1.3.8** During use, the battery may become very hot, allow the battery to cool before touching it.

**1.3.9 NEVER** pull or guide the machine using the cable and never pull on the cable to disconnect the plug.

**1.3.10 DO NOT** operate the machine when you are ill, feeling tired, or when under the influence of alcohol or drugs.

**1.3.11** Ensure that any trailing cable is protected against damage and not liable to be tripped over or trapped underneath the machine.

**1.3.12 DO NOT** use the Motor Guard as a Lifting Point.

**1.3.13 DO NOT** use this machine in wet conditions.

## 2. PRODUCT DATA

### 2.1 SPECIFICATIONS

MODEL	TMOP18e
Rated Voltage	36V
Brush Dimension	8.3in. X2
Brush Speed	0-450prm/min
Brush Motor Power	36V-120w
Brush Pressure	13.2 lb
Solution Tank Capacity	1.05 Gal
Recovery Tank Capacity	1.71 Gal
Noise Level	65-67 DB
Battery	78 Minutes
Weight (Net/Gross)	36.4/58.4 lb
Dimensions	45.7x21x11.2 in

## 2.2 Features

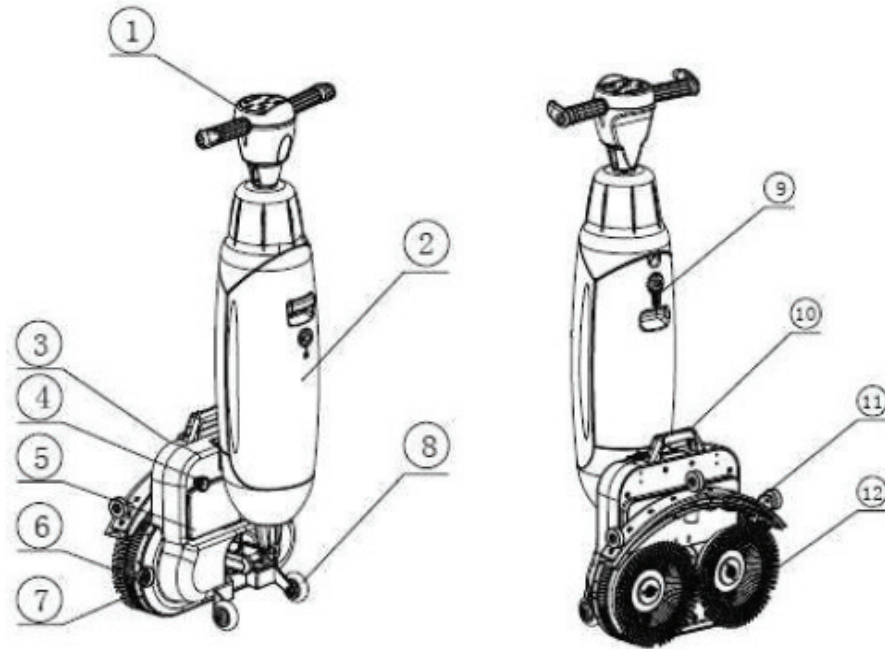

1	Top Handle	7	Surrounding Fence
2	Recovery Tank	8	Castor Wheels
3	Scrub Deck	9	Solution Tank
4	Battery Pack Box Knob	10	Carrying Handle
5	Battery Pack Box	11	Squeegee Assembly
6	Bumper Wheels	12	Brushes

### 2.3 Handle Features

2.3.1 Power switch (ON/OFF)

2.3.2 Water pump(ON/OFF)

2.3.3 Battery indicator

2.3.4 Vacuum Motor(ON/OFF)

2.3.5 Speed Adjustment- Low “-”

2.3.6 Speed Adjustment- High “+”

2.3.7 Brush Motor(ON/OFF)

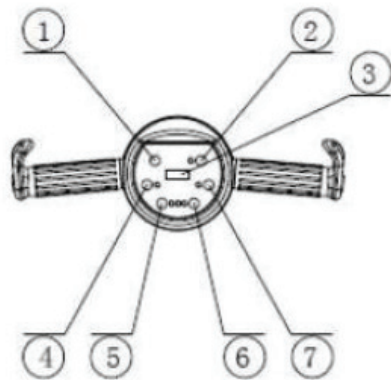

### 3. INTENDED USE OF THE EQUIPMENT

The TOMAHAWK® TMOP18e is designed with the intention of revolutionizing the way we clean our floors. Unlike traditional mops, the TOMAHAWK® TMOP18e operates on a rechargeable battery, eliminating the need for strenuous manual labor. The intended use of the TOMAHAWK® TMOP18e is to provide a convenient and efficient cleaning solution for various surfaces, including hardwood floors, tiles, and laminate. With its motorized spinning brushes, the TOMAHAWK® TMOP18e effortlessly removes dirt, grime, and stubborn stains, leaving floors sparkling clean.

#### 3.1 Non-Intended Use Of The Equipment

Using this mop for non-intended purposes can have consequences for the safety of operators and bystanders, and it may also void the warranty on the product.

**3.1.1 NEVER** operate the equipment near flammable dusts, liquids, or vapors.

**3.1.2 NEVER** operate the equipment when flammable or poisonous liquids like gasoline, oil acids, or other chemicals are present on the floor.

**3.1.3 DO NOT** fill the equipment with any flammable solutions. **ONLY** use water-based solutions.

**3.1.4 DO NOT** use cleaning solutions with a pH below 3 or above 11. Using these solutions can damage the equipment and void the warranty.

**3.1.5 DO NOT** use water that exceeds 113°F/45°C. Using water above this temperature will void the tank warranty.

**3.1.6 DO NOT** use the equipment outside or on uneven surfaces.

**3.1.7 DO NOT** store the equipment outside in order to avoid damage to electronic components.

**3.1.8 ONLY** use manufacturer supplied parts for maintenance.

**3.1.8 ONLY** trained adults that have read and understand the operation manual should operate the machine.

#### 3.2 Modifications

Any modifications made to the TOMAHAWK® TMOP18e will void the manufacturer warranty. Contact TOMAHAWK® customer service prior to any attempt at modification of machine.



## **4. OPERATION**

**BEFORE YOU START** always check the brushes and squeegee for wear and tear.

**NOTE:** It is not recommended to use the battery when charged below 40%

### **4.1 Filling the Cleaning Solution Tank**

- 4.1.1** Remove the stopper.
- 4.1.2** Pour in a maximum of 18gal/4L of cleaning fluid.
- 4.1.3** Replace the stopper and make sure it seals tight.
- 4.1.4** Put the TMOP18e in park position.
- 4.1.5** Put the tank on the TMOP18e with the valve first.
- 4.1.6** Press the tank downward to break the valve seal.
- 4.1.7** Push the tank into place until you hear a "click".
- 4.1.8** Clean your hands afterwards.

### **4.2 Operating The Equipment**

- 4.2.1** Crouch down while holding the carrying handle of the scrub deck firmly with one hand.
- 4.2.2** Push the handle forward with your other hand.
- 4.2.3** Bring the scrub deck slowly down to the floor.
- 4.2.4** Stand behind the TMOP18e.
- 4.2.5** Choose your cleaning mode via the mode buttons/switches, after pressing down the main On/Off switch first at the rear side of the control panel. Meanwhile, the battery indicator will illuminate power.
- 4.2.6** Hold the handle with both hands.
- 4.2.7** Walk behind the TMOP18e.
- 4.2.8** Steer by gently turning the handle left or right to move the scrub deck.

### **4.3 MODES**

**MODE 1:** Vacuum Only

**MODE 2:** Brush Only

**MODE 3:** Water/Cleaner Solution Only

**MODE 4:** Vacuum + Brush

**MODE 5:** Vacuum + Water/Cleaning Solution

**MODE 6:** Brush + Water/Cleaning Solution

**MODE 7:** Brush + Water/Cleaning Solution + Vacuum

### 4.3 Modes Continued

**NOTE: Press all corresponding buttons for MODE**



### 4.4 Stopping the Equipment

**Note:** Releasing the main ON/OFF switch will immediately stop the machine.

**4.4.1** Press water cleaning button to stop the water releasing

**4.4.2** Press brush button to stop the brush

**4.4.3** Press vacuum button to stop the vacuum

**4.4.4** Press power to shut off

## 5. CLEANING & STORAGE

### 5.1 Cleaning

**5.1.1** Dispose water or cleaning solution from both tanks in an appropriate drain.

**5.1.2** To clean the recovery tank thoroughly:

- Partially fill the tank with fresh water and hold it horizontally with the holes facing up.
- Tilt the tank repeatedly, thoroughly rinsing all the dirt and debris out from the tank.

**5.1.3** To clean the solution tank, follow the same procedure.

**Tip:** Dry the tanks to avoid needing a replacement.

**5.1.4** Check to see if both brushes are clean and intact.

- Clean the under fresh water or replace them if necessary.
- Replace brushes if the yellow wear indicator is the same height as other bristles.

**5.1.5** Check to see if the squeegee is clean and intact.

- Clean it with fresh water and wipe it with a clean, damp cloth.
- Replace the squeegee blades when necessary.

## 5.2 Storage

**5.2.1** Please ensure that the machine is parked in a place where nobody can bump into it.

**5.2.2** Put the machine in the park position.

**5.2.3** Store the machine close to a wall with the handle pointing towards the wall and the brushes facing away from the wall.

## 6. MAINTENANCE

### 6.1 Brush Replacement

**6.1.1** Put the machine in the park position.

**6.1.2** The brushes connect on the machine by magnetic force. Grab the left and right side of the brushes (stripping pads holder) with two hands and pull the brush out against machine.

**6.1.3** Visually inspect the motor disks

**6.1.4** Clean the machine's scrub deck with a clean, dry cloth before installing the brushes or stripping pads holder.

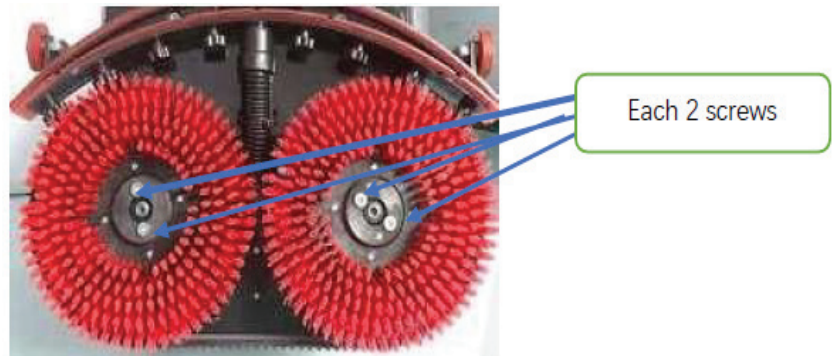

### 6.2 Squeegee Replacement

The squeegee blades come in pairs and wear out over time. When you notice the floor is no longer being dried properly, replace the squeegee blades.

**6.2.1** Put the machine in the park position.

**6.2.2** Hold the scrub deck firmly with one hand.

**6.2.3** Use the supplied hex wrench to remove the two hexagonal screws inside the squeegee completely.

**6.2.4** Pull out the squeegee properly.

**6.2.5** Remove the vacuum hose from the squeegee by twisting the hose.

**6.2.6** Unscrew the 8 plastic nuts on the back (refer to the previous image).

**6.2.7** Take off the squeegee rear plate.

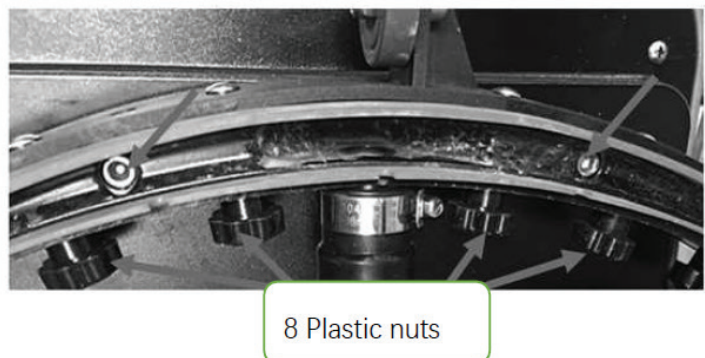

**6.2.8** Once the plastic part is removed, you can easily take off the rear rubber blade.

**6.2.9** Push the 8 screws through the front blade in order to remove the squeegee front plate.

**6.2.10** Take off the rear rubber blade.

**6.2.11** Inspect the front and rear rubber blades:

- The first time: flip the blades so the top of the blade is now facing the floor. Push the front plate screws through the holes.
- The second time: attach a new set of blades. Push the front plate screws through the holes.

**NOTE:** The special squeegee blades that contain small arrow-like shapes cannot be switched. These need to be replaced everytime.

- Put back the plastic rear plate.
- Screw the 8 plastic nuts on the back.

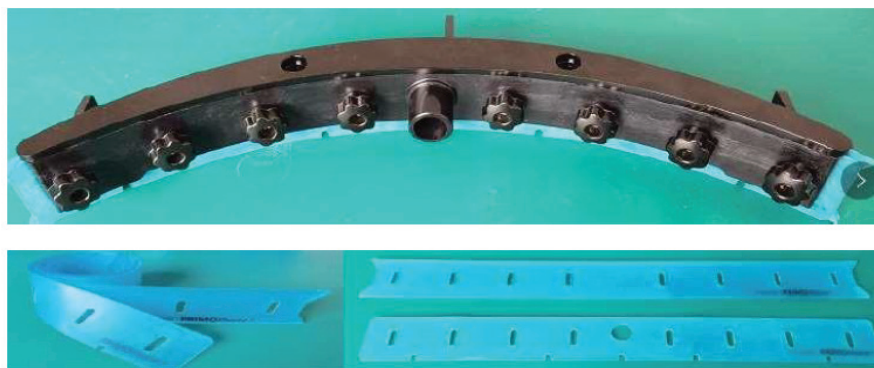

### **6.3 Attaching a New Squeegee**

**6.3.1** Take the vacuum hose

**6.3.2** Insert the hose connector (refer to the above image) in the Squeegee.

**6.3.3** Twist the hose connector 1/4 turn for a firm fit.

**6.3.4** Carefully pull the vacuum hose from the top of the machine

**6.3.5** Hold the scrub deck firmly with one hand.

**6.3.6** Align the pins on the scrub deck with the holes on the squeegee.

**6.3.7** Screw the squeegee in place

### **6.4 Replacing The Hose**

**6.4.1** Detach the squeegee as described in above sections.

**6.4.2** Remove the solution tank. You can see where the vacuum hose is connected at the AMOP-3 handle.

**6.4.3** Hold the scrub deck firmly with one hand,

**6.4.4** Detach the vacuum hose by twisting the connector 1/4 turn anticlockwise.

**6.4.5** Now you can carefully pull the vacuum hose from the top of the machine.

**6.4.6** Guide the new vacuum hose via the opening to the hose connector located at the AMOP-3 handle.



## 7. TROUBLESHOOTING

Problem	Cause	Solution
No power	No Battery pack	Put battery pack
	Empty battery pack	Charge battery pack
	Battery pack incorrectly connected	Reconnect battery pack
Insufficient/no water flow	Wrong switch on	Check the switch button on the control panel
	Main on/off switch is "off"	Check the main on/off switch button
	Empty tank	Fill the tank
	Tank incorrectly placed	The tank valve must be clicked on the nipple to open the seal, replace the tank
	Filter blocked	Ensure the solution tank have no dirt particles and the filter is clean
	Blocked water Pipe	Request for service
Poor water recovery	Squeegee opening blocked	Remove the pipe and clean the squeegee opening
	Tears in squeegee blades	Replace squeegee blades
	Filter blocked	Check the foam filter and clean if necessary
	Vacuum hose blocked	Check and remove blockage
	Vacuum motor not running	Request for service
leakage	Tanks incorrectly placed	Check and reattach fluid tanks
	Tear in vacuum hose	Replace vacuum hose or request for service
Battery not charging	Battery is at end of life	Replace battery

## **8. REPLACEMENT PARTS**

**8.1** For replacement parts and technical questions visit [www.tomahawk-power.com](http://www.tomahawk-power.com)

**8.2** Not all equipment components are available for replacement. The illustrations within this manual are a convenient reference to the location and position of parts in the assembly sequence.

**8.3** When ordering parts, the following will be required: equipment model number, serial number/lot, date code, and description.

**8.4** The distributor reserves the right to make design changes and/or improvements to equipment, parts, accessories, and manuals without notice.

## **9. WARRANTY**

Your new TOMAHAWK® equipment is warranted to the original purchaser for a period of one-year.

(12 months) from the original date of purchase. The TOMAHAWK® warranty is against defects in design, materials and workmanship.

*The following are not covered under the warranty:*

1. Damage caused by abuse, misuse, dropping or other similar damage caused by or as a result of failure to follow assembly, operation or user maintenance instructions.
2. Alterations, additions or repairs carried out by persons other than TOMAHAWK® or their recognised agents.
3. Transportation or shipment costs to and from TOMAHAWK® or their recognised agents, for repair or assessment against a warranty claim, on any machine.
4. Materials and/or labor costs to renew, repair or replace components due to fair wear and tear.

TOMAHAWK® and/or their recognised agents, directors, employees or insurers will not be held liable for consequential or other damages, losses or expenses in connection with or by reason of or the inability to use the machine for any purpose.

### **9.1 Warranty Claims**

Before submitting any warranty claim, your new TOMAHAWK® equipment should be registered through [www.tomahawk-power.com](http://www.tomahawk-power.com). Follow the steps on page 3 to complete the equipment registration. After registration is complete, all warranty claims should firstly be directed to TOMAHAWK® through the online Service Request form found at [www.tomahawk-power.com](http://www.tomahawk-power.com)



# TAKE BACK YOUR YARD

## Enjoy the outdoors again.

Tomahawk mosquito foggers deliver the power to eliminate virus-carrying pests, before they ruin outdoor activities for your friends and family. **10x Faster** than manual sprayers, cover 1 acre in less than 30 minutes with **40ft of Reach**. Great for year-round use, Tomahawk Foggers are also an excellent leaf blowing solution. No matter the season, keep your yard pest free and looking great!



Item #: TMD14

### 3.7 GALLON TURBO BACKPACK FOGGER

[www.tomahawk-power.com](http://www.tomahawk-power.com)







# CLEAN MORE IN LESS TIME

For big areas and busy schedules, Tomahawk 38" push sweepers cover a wider path to reach more surface area so you can finish sweeping faster around indoor and outdoor spaces and on wet or dry surfaces!



Item #: TOS38  
**14.5** GAL **COMMERCIAL**  
**38" PUSH SWEEPER**

[www.tomahawk-power.com](http://www.tomahawk-power.com) 

# TOMAHAWK

## PRODUCT CATALOG

### COMPACTION



HONDA  
ENGINES

**3,550 lbs/ft Vibratory Rammer**  
Part#: TR68H

3.6 HP Honda GXR120 Engine  
Easily achieve a 100% compaction rating  
3-in-One Fuel System with carburetor protection  
13" x 11" plate for narrow trenches and corners  
3 Year Engine Warranty & 1 Year Product Warranty



HONDA  
ENGINES

**3,400 lbs/ft Plate Compactor**  
Part#: TPC90H

5.5 HP Honda GX160 Engine  
Easily achieve a 100% compaction rating  
22" x 20" cold, rolled steel beveled base plate  
Includes 3.5 gallon water tank for asphalt compaction  
3 Year Engine Warranty & 1 Year Product Warranty



HONDA  
ENGINES

KOHLER  
ENGINES

**3,000 lbs/ft Plate Compactor**  
Part#: TPC80 & TPC80H

6 HP Kohler CH260 & 5.5 HP Honda GX160 Engines  
Easily achieve a 100% compaction rating  
16.5" x 21.5" plate for narrow trenches and corners  
Optional Honda Engine model: TPC80H  
3 Year Engine Warranty & 1 Year Product Warranty

### FINISHING



**6.5 Gal Backpack Concrete Sprayer**  
Part#: TCS6.5

Maintain constant, adjustable pressure up to 450 PSI  
Achieve superior concrete finishes with even spraying  
Spray 15,000 sq ft in less than 10 minutes  
Compatible with major manufacturer wands  
1 Year Product Warranty



HONDA  
ENGINES

**1.6 HP Vibratory Concrete Screed**  
Part#: TVSA-H

1.6 HP Honda GX35 Engine  
Aluminum Magnesium blades available from 8ft - 14ft  
Finish concrete 4X faster than other screed methods  
360° adjustable handle placement  
3 Year Engine Warranty & 1 Year Product Warranty



HONDA  
ENGINES

**6" Early Entry Green Concrete Saw**  
Part#: TFS6H

5.5 HP Honda GX160 Engine  
Maximum cutting depth of 1 3/16 inches  
OSHA compliant vacuum port for dust collection  
Includes 6" early entry concrete blade  
3 Year Engine Warranty & 1 Year Product Warranty

### FINISHING



HONDA  
ENGINES

**1.6HP Backpack Concrete Vibrator**  
Part#: TVIBH + TVW10-P

1.6 HP Honda GX35 engine  
Consolidation with speeds of 10,000-12,000 VPM  
Quick Connect centrifugal clutch vibrator  
1" and 2" Diameter Whips Available in 10ft Length  
3 Year Engine Warranty & 1 Year Product Warranty

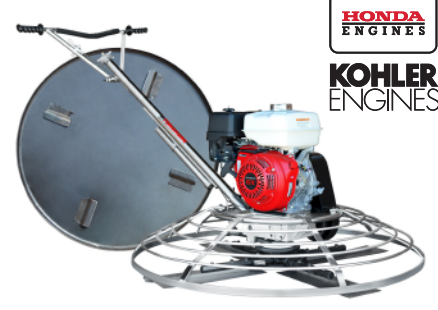

HONDA  
ENGINES

KOHLER  
ENGINES

**36" & 46" Concrete Power Trowel**  
Part#: TPT36H/K & TPT46H/K

6 HP/14HP Kohler & 5.5HP/8.5HP Honda Engines  
Adjust trowel blade pitch from 0-28°  
60-115 RPM rotor speed for superior concrete finishes  
Includes float pan and trowel blades  
3 Year Engine Warranty & 1 Year Product Warranty



HONDA  
ENGINES

**8" Gas Powered Concrete Scarifier**  
Part#: TSCAR8H

5.5 HP Honda GX160 Engine  
Remove traffic lines at 800 - 1,000 linear ft/hr  
Tungsten Carbide Blade Kit Available  
OSHA approved dust port for silica vacuum removal  
3 Year Engine Warranty & 1 Year Product Warranty

HAVE QUESTIONS?

Contact us. *We're here to help!*

Email us at [sales@tomahawk-power.com](mailto:sales@tomahawk-power.com)

**10% OFF**

USE CODE

**SAVE10**

AT CHECKOUT FOR

**10% OFF YOUR ORDER AT**

**WWW.TOMAHAWK-POWER.COM**

**POWER / WELDING**

INVERTER SERIES



**2000 Watt Inverter Generator**  
Part#: TG2000i

2000 Max Watts, 1600 Rated Watts  
Run Time of 8 hours on 1 gallon of gas  
OSHA and GFCI Compliant  
Parallel technology capable for double the power  
2 Year Product Warranty

INVERTER SERIES



**210 Amp Portable Welder Generator**  
Part#: TWG135Ai

Steady 50 - 135 Amp DC welding output  
3300 Watt Inverter Generator  
60% Duty Cycle for extended use  
Suitable for welding rods from 6010 to 7024  
2 Year Product Warranty



**210 Amp Portable Welder Generator**  
Part#: TWG210A

Steady 50 - 210 Amp DC welding output  
2000 Watt Inverter Generator  
60% Duty Cycle for extended use  
Suitable for welding rods from 6010 to 7024  
2 Year Product Warranty

**PEST CONTROL**



**3.7 Gallon 3HP Backpack Fogger**  
Part#: TMD14

Turbo Boosted Pump with 40ft + Horizontal Reach  
Sprays 1 acre in 30 minutes  
10X Faster than Manual Pump Sprayers  
Converts to Leaf Blower with 200 MPH Air Velocity  
1 Year Product Warranty



**4.75 Gallon Battery Power Sprayer**  
Part#: eTPS18

Reach Up to 30ft Horizontal Reach  
Sprays 6000 sq ft in 10 minutes  
10X Faster than Manual Pump Sprayers  
70 PSI Commercial Grade Pump  
1 Year Product Warranty



**5 Gallon Backpack Power Sprayer**  
Part#: TPS25

Reach Up to 30ft Horizontal Reach  
Sprays acres in 10 minutes  
10X Faster than Manual Pump Sprayers  
50-435 Adjustable PSI Commercial Grade Pump  
1 Year Product Warranty

**AND MORE**



**4 Gal. Motorized Fertilizer Spreader**  
Part#: TGS30

Reach up to 30ft Horizontally  
Sprays 1 acre in 30 minutes  
20X Faster than push spreaders  
Converts to Leaf Blower with 200 MPH Air Velocity  
1 Year Product Warranty



**3" Full Trash Water Pump**  
Part#: TW3H

Moves liquids at a rate up to 375 gal/min  
Handle solids up to 1.5"  
Silicone carbide seals and a chrome plated volute  
8 HP engine protected by rugged all purpose frame  
3 Year Engine Warranty & 1 Year Product Warranty



**Commercial 38" Push Sweeper**  
Part#: TOS38

Collect up to 14.5 gallons of dust and debris  
Can be used indoors & outdoors on wet or dry surfaces  
Includes integrated airflow control and fine dust filter  
Lightweight design, capable of fitting through doorways  
1 Year Product Warranty

ASSEMBLED IN THE  
**USA**  
PARTS SOURCED GLOBALLY

\* All coupons in this manual are valid only for orders placed on [www.tomahawk-power.com](http://www.tomahawk-power.com), unless otherwise noted. Coupon codes may only be used once per customer and may not be combined with any other offer. Coupons may expire at any time without notice.

(866) 577-4476

[www.tomahawk-power.com](http://www.tomahawk-power.com)



## Power Your World

Tomahawk understands to keep a job-site running smoothly the proper equipment and spare parts are needed at the drop of a hat. With same day shipping and faster delivery times, count on Tomahawk to keep you powered throughout the day! With long lasting parts and engines, Tomahawk equipment will be the star of your fleet for years to come. Visit [www.tomahawk-power.com](http://www.tomahawk-power.com) to get started today!

# TOMAHAWK

TOMAHAWK®, LLC  
San Diego, CA

**Sales Support**  
(866) 577-4476  
[sales@tomahawk-power.com](mailto:sales@tomahawk-power.com)

**Equipment Support**  
(866) 577-4476  
[support@tomahawk-power.com](mailto:support@tomahawk-power.com)

[www.tomahawk-power.com](http://www.tomahawk-power.com)



**FACEBOOK**  
[facebook.com/TomahawkPowerUSA](https://facebook.com/TomahawkPowerUSA)

**YOUTUBE**  
[youtube.com/TomahawkPower](https://youtube.com/TomahawkPower)

**INSTAGRAM**  
[@tomahawkpower](https://instagram.com/tomahawkpower)