

## Safety Precautions

Please read the following information carefully before using this product to ensure safety



HANDLE WITH CARE.



TO AVOID INJURY DO NOT LEAN AGAINST LID WHEN BEING USED.



AVOID EXPOSURE TO DIRECT SUNLIGHT FOR EXTENDED PERIODS OF TIME.



ENSURE WASTE TANK IS CLEANED REGULARLY.



AVOID HIGH TEMPERATURES OVER 122°F.



SUITABLE FOR USE WITH ANY BRAND OF PORTABLE TOILET CHEMICALS AND DEODORIZERS.

## Product Overview Parts Identification

1. Seat Cover
2. Seat
3. Hinge Pin
4. Piston Pump Assembly
5. Cap for Fresh Water Tank
6. Fresh Water Tank
7. Latch Assembly
8. Sealed C-Ring
9. Slide Valve Assembly
10. Sealed D-Ring
11. Spout Cap
12. Emptying Spout
13. Waste Tank

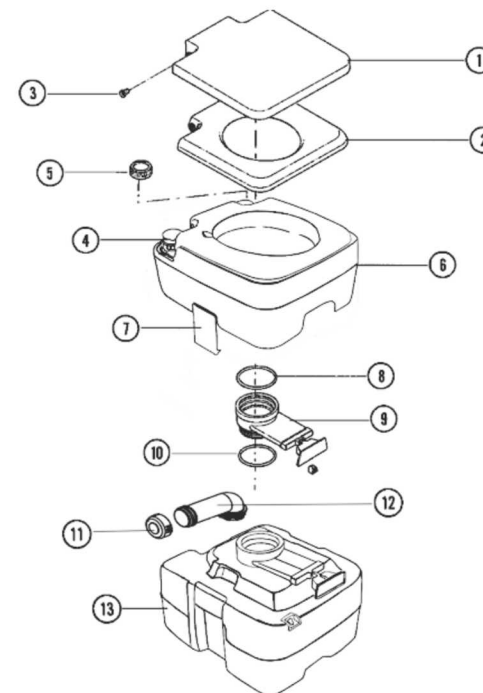

## Preparing for Use

1. Position the toilet on its front side so that the cap on the waste holding tank is in a vertical position. Remove the cap and add deodorizer following instructions on the deodorizer container. Tighten the cap firmly.

2. Position the toilet in an upright position and remove the cap located on the right rear side of the fresh water tank. Fill with fresh water up to the top of the fresh water tank. Then tighten the cap firmly. Do NOT add cleaning agents or chemicals. Use fresh water only.



## Cautions:

- Avoid adding holding tank deodorizer through bowl. Use cap on the bottom rear tank if possible. Rinse off any spilled or splashed deodorizer immediately.
- Atmospheric pressure and temperature changes may cause pressure build up in lower holding tank. Caution should be used when first opening the slide valve.
  - a. Press the air relief valve button.
  - b. Pull the slide valve; close slide valve.

**Note:** Change of air pressure and temperature may cause pressure in the waste tank compartment. Before using, press the exhaust valve button then pull the slide valve to avoid waste spill.

## General Operation

1. Close slide valve by pushing in fully.
2. Depress piston pump to add water to the bowl.
3. After use, pull slide valve handle out.
4. Depress piston pump again to rinse the bowl.
5. Close slide valve by pushing in fully.



## Emptying the Holding Tank

1. Slide valve handle all the way in.
2. Unlatch upper unit (side latches) and lift from holding tank.
3. Carry holding tank to permanent toilet facility.
4. Remove cap on the emptying spout.
5. Empty contents into toilet.
6. Rinse tank thoroughly.
7. Replace cap.
8. Reassemble unit and prepare for use.

## Cleaning and Maintenance

1. Lubricate slide valve seals periodically with silicone spray or white grease lubricant.
2. The slide valve may be removed for cleaning or inspection by simply unscrewing in a counter clockwise direction.
3. Clean exterior of toilet with a mild, non-abrasive bathroom cleaner.

## Storage

1. Empty the top tank and waste holding tank.
2. Make sure all water is cleared from the piston pump by depressing pump several times.
3. Store away from direct sunlight.

**Note:** A small amount of water may remain in the top tank but will be harmless during storage.

## Specifications

Dimensions: 16.5 x 14.6 x 16.9 in.

Fresh Water Tank: 3.16 gal. / 12.13 lbs.

Waste Water Tank: 5.3 gal. / 12.13 lbs.

- High-density polyethylene construction
- Completely self-contained
- No power source or plumbing connections required
- Secure clamps and latches
- All parts easily replaced
- 5.3 gallon waste holding tank
- 2.6 gallon fresh water tank
- Easy to carry and clean
- Well-constructed adult-sized seat and lid
- Always flushes with clean water, no re-circulating water
- Tank capacity provides up to 50 flushes.
- Attractive matte finish conceals marks, and allows scrubbing without damage
- Double-sealed drain valve protects against leakage and odor
- Heavy duty, corrosion-resistant side latches lock tanks together
- Easy-to-empty detached waste holding tank
- Single-piece construction (both tanks) with non-leak seams
- Empty waste easily without tools
- Selectable bracket to increase height
- No-splash rotating spout to dispose of waste
- 3-directional nozzle
- Piston pump
- Level indicator
- Exhaust valve

## Features

This product is covered by a limited one-year warranty. Coverage is subject to limits and exclusions.  
\* See warranty for details.

Please read all directions before using the product and retain this guide for reference. This product is intended for household use only.

Thank you for purchasing the Hike Crew™ Power Flush Portable Camping Toilet. This User Guide is intended to provide you with guidelines to ensure that operation of this product is safe and does not pose risk to the user. Any use that does not conform to the guidelines described in this User Guide may void the limited warranty.

**POWER FLUSH**  
PORTABLE CAMPING TOILET  
USER GUIDE



HCCHH3320



CUSTOMER SERVICE:  
info@supportcbp.com  
1-833-665-2122

This product is covered by a limited one-year warranty.  
\* Please see warranty information on our website at

[www.hikecrew.com](http://www.hikecrew.com).



**POWER FLUSH**  
PORTABLE CAMPING TOILET  
USER GUIDE

HCCHH3320