



Rollie
DLX™

Rollie™

3-WHEEL LIGHT-UP SCOOTER



OWNER'S MANUAL

Read and understand this entire manual before allowing child to use this product!

For assistance contact Razor. DO NOT RETURN TO STORE.

NOTE: Manual illustrations are for demonstration purposes only. Illustrations may not reflect exact appearance of actual product. Specifications subject to change without notice.

Please have your 22 character product I.D. code ready before contacting Razor for warranty assistance and/or replacement parts.

Product I.D. Code: _____ - _____ - _____

CONTENTS

Safety Warnings.....	1-2	Usage.....	8
Before You Begin.....	3	Repair and Maintenance.....	9
Assembly and Set-Up.....	4-7	Product Parts.....	10
Pre-Ride Checklist.....	7	Warranty and Contact Information.....	11

SAFETY WARNINGS

⚠ AN IMPORTANT MESSAGE TO PARENTS:

Razor products are intended to allow younger children to learn and to enjoy their early experiences using ride-on toys. Studies suggest that children at age 3 have the coordination required to use a steering wheel or handlebar and can use a 3-wheeled scooter, but may not have developed the balance required to operate 2-wheeled scooters. This ability is expected to develop with time and experience to where, depending on experience, most children by the age of 5 have the balance and coordination to use 2-wheeled scooters.

Adult supervision is required as children learn and grow because children do not understand the risks of riding in areas with cars and are at a very high risk of falling off and injuring themselves as they first experience the fun – and the risks – of riding something using their own power and skill. Protecting children as they learn is an important part of the developmental process.

Parents need to make any decisions to “convert” the Rollie from a seated to a standing configuration, based upon the parents’ assessment of their child’s development of balance, skills and maturity used in riding 3-wheeled products.

This manual contains important information. For your child’s safety, it is your responsibility to review this information and make sure that you instruct your child to follow all warnings, cautions, instructions, and safety topics. Razor USA recommends that adults periodically review and reinforce the information in this manual with younger riders and that you inspect and maintain your child’s scooter to ensure their safety.

⚠ WARNING: PARENTAL AND ADULT RESPONSIBILITY AND SUPERVISION IS NECESSARY:

Riding a Razor Rollie does present potential risks and caution is required. Because products, like the Rollie, can and do present potential hazards plainly associated with their use, it is well recognized THE NEED FOR EXERCISE OF PARENTAL RESPONSIBILITY IN SELECTING RIDING PRODUCTS APPROPRIATE TO THE AGE OF A CHILD, OR PARENTAL SUPERVISION IN SITUATIONS IN WHICH CHILDREN OF VARIOUS AGES MAY HAVE ACCESS TO THE SAME RIDING PRODUCTS, IS IMPORTANT.

Not every product is appropriate for every age or size of child, and different age recommendations are found within this category of product which are intended to reflect the nature of the hazards and the expected mental or physical ability, or both, of a child to cope with the hazards.

Keep this product away from very small children and remember that it is intended for use only by children who are, at a minimum, completely comfortable and competent while operating the Rollie.

Children with any mental or physical conditions that may make them susceptible to injury, impair their physical dexterity or mental capabilities to recognize, understand, and follow safety instructions and to be able to understand the hazards inherent in Rollie use, should not use or be permitted to use products inappropriate for their abilities.

⚠ WARNING: Scooter riding can be a hazardous activity.

Certain conditions may cause the equipment to fail without fault of the manufacturer. Scooters can and are intended to move, and it is therefore possible to get into dangerous situations and/or lose control and/or fall. If such things occur, you can be seriously injured or die, even when using safety equipment and other precautions. LIKE ANY OTHER MOVING PRODUCT, USING A SCOOTER CAN BE A DANGEROUS ACTIVITY AND MAY RESULT IN INJURY OR DEATH EVEN WHEN USED WITH PROPER SAFETY PRECAUTIONS. USE AT YOUR OWN RISK AND USE COMMON SENSE.

This manual contains many warnings and cautions concerning the consequences of failing to maintain, inspect or properly use the Razor scooter. Because any incident can result in serious injury or even death, we do not repeat the warning of potential serious injury or death each time such a possibility is mentioned.

- Do not allow children under age thirty (30) months to use this product. Direct adult supervision is required at all times. The recommended rider age of thirty (30) months to 4 years for Rollie is only an estimate, and can be affected by the rider’s size, weight, or skills. Any rider unable to fit comfortably on the Rollie should not attempt to ride it.
- Riders 30-36 months should only ride with the seat installed.
- Always pay attention to where your child is going.
- Safety equipment, such as helmet, knee pads and elbow pads are recommended. Always ensure your child is wearing a helmet when riding this scooter and keep the chinstrap securely buckled.
- Always wear closed toe shoes.
- Ride on smooth, paved surfaces without loose debris, such as rocks or gravel, and away from motor vehicles.
- Avoid sharp bumps, drainage grates, and sudden surface changes as scooter may suddenly stop.
- Avoid streets and surfaces with water, puddles, mud, ice, sand, gravel, dirt, leaves and other debris. Wet weather impairs traction, stopping, and visibility.
- Do not ride at night or when visibility is impaired.
- Brake may get hot from continuous use. Do not touch after braking.
- Avoid excessive speed associated with downhill rides.
- Obey all local traffic and scooting laws and regulations.
- Watch out for pedestrians.
- **DO NOT EXCEED 43 LB (19.5 KG) TOTAL WEIGHT ON THE RAZOR SCOOTER.**
- **RIDER WEIGHT DOES NOT NECESSARILY MEAN A CHILD’S SIZE IS APPROPRIATE TO FIT OR MAINTAIN CONTROL OF THE SCOOTER.**
- **A parent’s decision to allow his or her child to ride this product should be based on the child’s maturity, skill, and ability to follow rules.**

SAFETY WARNINGS

ACCEPTABLE RIDING PRACTICES AND CONDITIONS

Direct parental supervision is required at all times. Always check and obey any local laws or regulations which may affect the locations where the Rollie may be used on public property. Scooters are meant to be used only in controlled environments, free of potential traffic hazards and not on public streets. Do not allow your child to ride a scooter in any areas where vehicle traffic is present. Never allow more than one child at a time to ride a scooter. Never use near streets, steps, sloped driveways, hills, roadways, alleys, or swimming pool areas. Never allow your child to use headphones, a cell phone or text when riding. Never allow your child to hitch a ride with a vehicle.

The Rollie is intended for use on solid, flat, clean and dry surfaces, such as pavement or level ground, without loose debris, such as dirt, leaves, rocks or gravel.

Child must maintain a hold on the handlebars at all times.

Ride defensively. Watch out for potential obstacles that could catch the wheel or cause the rider to swerve suddenly or lose control. Be careful to avoid pedestrians, skaters, skateboards, scooters, electric products, bikes, children or animals who may enter your path, and respect the rights and property of others.

PROPER RIDING ATTIRE

Always ensure child is wearing proper protective equipment, such as an approved safety helmet and keep chinstrap securely buckled. A helmet may be legally required by local law or regulation in your area. A long-sleeved shirt, long pants, and gloves are recommended. A child should always wear shoes, never ride barefooted or in sandals, and keep shoelaces tied and out of the way of the wheels. Knee pads and elbow pads are recommended.

⚠ WARNING: ALWAYS INSPECT SCOOTER PRIOR TO RIDING. Properly inspecting and maintaining the scooter can reduce the risk of injury. Always inspect the scooter before riding and regularly maintain it. Replace worn parts when they occur.

⚠ WARNING: CHECK LOCAL LAWS REGARDING SCOOTER USE. Check local laws and regulations to see where and how you may use your scooter legally. In many states and local areas scooter riders are required BY LAW to wear a helmet. Check local laws and regulations regarding laws governing helmet use and scooter operation in your area.

⚠ WARNING: AAA BATTERIES This product contains AAA batteries. A swallowed AAA battery can cause internal chemical burns. Dispose of used batteries immediately. Keep new and used batteries away from children. If you think batteries might have been swallowed or placed inside any part of the body, seek immediate medical attention.

Batteries included for lights - adult attention for installing, changing and disposal.

Batteries should only be installed or replaced by an adult.

Loose batteries could present a choking hazard and should be kept away from small children.

Dispose of batteries properly.

FAILURE TO USE COMMON SENSE AND HEED THE ABOVE WARNINGS FURTHER INCREASES RISK OF SERIOUS INJURY. USE AT YOUR OWN RISK AND WITH APPROPRIATE AND SERIOUS ATTENTION TO SAFE OPERATION. USE CAUTION.

Need Help? Visit our website for replacement parts, product support, a list of authorized service centers in the US and customer service contact information at www.razor.com. Please have the product I.D. code (located on the white label of your product) available for better assistance. Additional Customer Service contact information is listed at the back of this manual.

BEFORE YOU BEGIN

Adult assembly required. Remove contents from box. Inspect the contents for scratches in the paint and/or dents that may have occurred during shipping. Because your scooter was partially assembled and packed at the factory, there should not be any problems, even if the box has a few scars or dents.

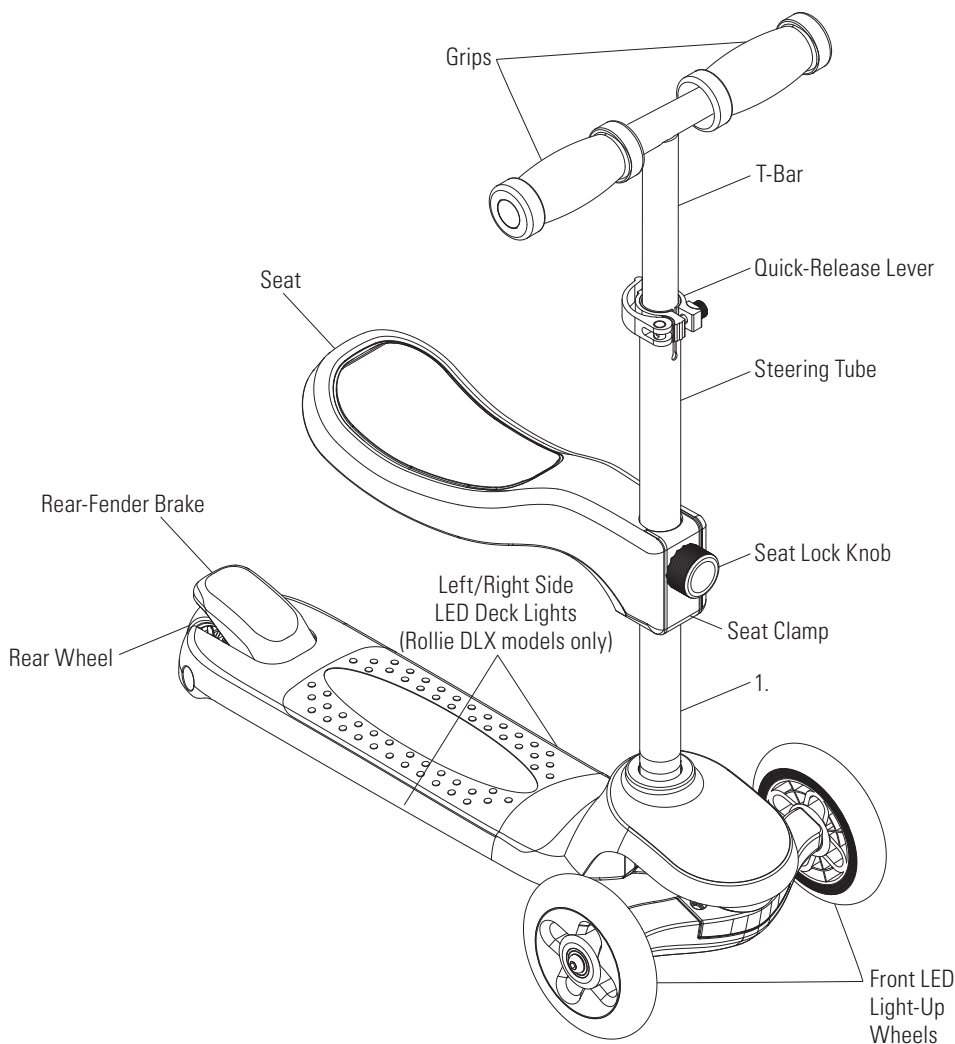

⚠ WARNING: DO NOT USE NON-RAZOR PRODUCTS WITH YOUR RAZOR SCOOTER. Razor scooters have been built to certain Razor design specifications. The original equipment supplied at the time of sale was selected on the basis of its compatibility with the frame and all other parts. Certain aftermarket products may not be compatible and will void the warranty.

Product ID Locations:

(See locations to the left)

1. T-Bar
2. Box - Side of UPC (Not Shown)

Box Contents:

- Scooter
- Three (3) AAA Batteries (Rollie DLX models only)
- Owner's Manual

ASSEMBLY AND SET-UP

□ Installing and Replacing the Batteries (Rollie DLX models only)

Required Tool: Phillips Screwdriver (not included)

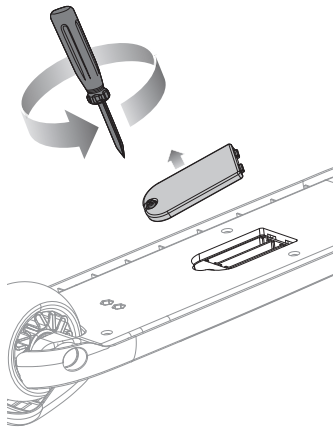

1 Using a Phillips screwdriver, loosen the screw from the top of battery cover. Remove the battery cover and set aside.

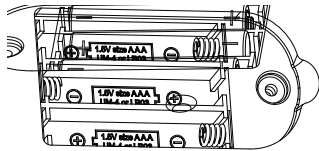

Note: When installing the batteries, please pay attention to the batteries' positive and negative side which must align with the positive and negative markings in the battery housing.

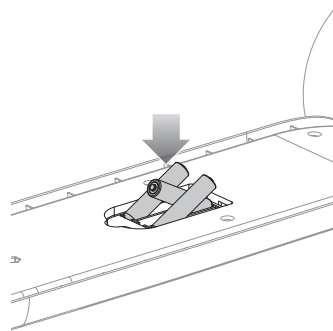

2 To install batteries, insert three (3) AAA batteries (included) into battery housing. If replacing batteries, remove and discard the old batteries before inserting new batteries.

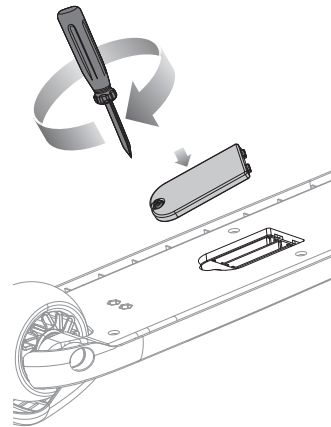

3 Replace the battery cover and tighten the screw using a Phillips screwdriver.

⚠ WARNING:

- AAA batteries included for lights - adult attention for installing, changing and disposal.
- Batteries should only be installed or replaced by an adult.
- Loose batteries could present a choking hazard and should be kept away from small children.
- Do not mix old and new batteries.
- Do not mix alkaline, standard (carbon-zinc) or rechargeable (ni-cad, ni-mh, etc.) batteries.
- Dispose of batteries properly.

Note: Batteries are not covered under the Limited Warranty.

□ Attaching the Handlebars

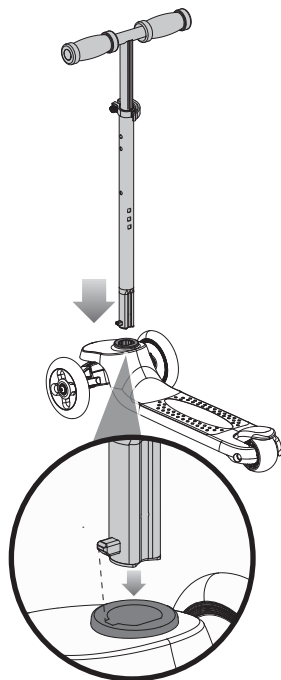

Align the spring pin with the bottom mounting gap, press the spring pin and insert the T-bar into the frame bottom plate until the spring pin ejects from the specified position.

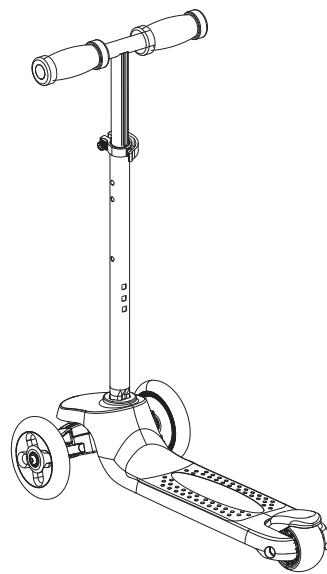

Note: After attaching the handlebars. Step on the deck and pull up on the T-bar to confirm the T-bar is in a locked position.

⚠ WARNING: Failure to properly engage the spring-loaded buttons may cause the handlebars to dislodge while riding and may cause you to lose control and fall. When correctly engaged the handlebars will not rotate nor will they move sideways. Note that when properly engaged, the spring-loaded buttons are clearly visible in the holes on the extension tube.

⚠ WARNING: Check hand grips regularly for wear or damage, as grips are designed to aid in gripping handlebars and to provide some protection against possible impact. Replace immediately if worn, torn, damaged or missing.

NOTE: Make sure the Razor logo is facing outward when inserting the T-bar.

ASSEMBLY AND SET-UP

□ Adjusting the Handlebars

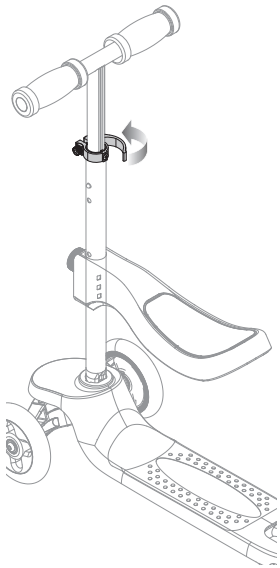

1 To adjust the height of the handlebars, open the quick-release lever.

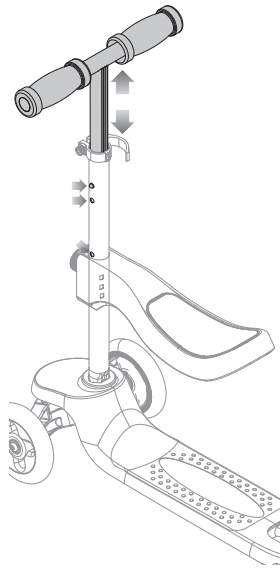

2 Slide the T-bar to the desired position and resecure the quick-release lever to lock into place. When the T-bar is raised to the maximum height, depress the push button located directly below the quick-release lever to unlock the T-bar.

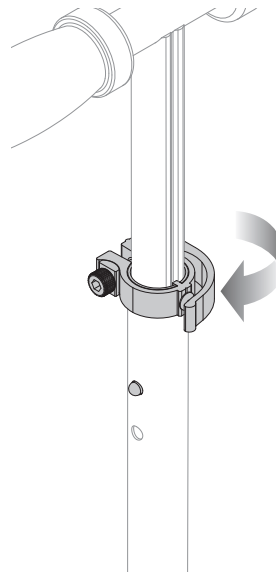

3 Close the quick-release lever.

⚠ WARNING: Failure to properly secure the quick-release lever may cause the T-bar to telescope up or down while riding and may cause you to lose control and fall.

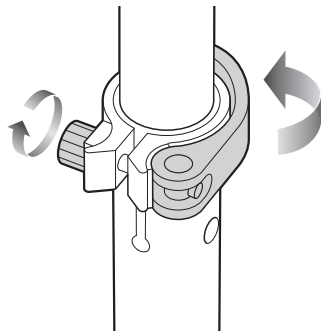
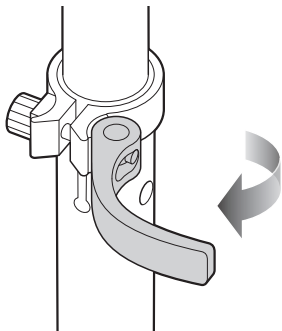

Note: The tension of the quick-release lever can be adjusted by manually tightening or loosening the Allen bolt. Be careful not to over-tighten. You should always be able to open and close the quick-release lever by hand and the T-bar should slide freely when the quick-release is open.

Need Help? Visit our website for replacement parts, product support, a list of authorized service centers in the US and customer service contact information at www.razor.com. Please have the product I.D. code (located on the white label of your product) available for better assistance. Additional Customer Service contact information is listed at the back of this manual.

ASSEMBLY AND SET-UP

Attaching and Removing the Seat

□ Attaching the Seat

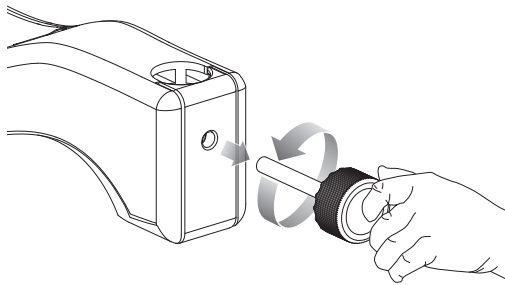
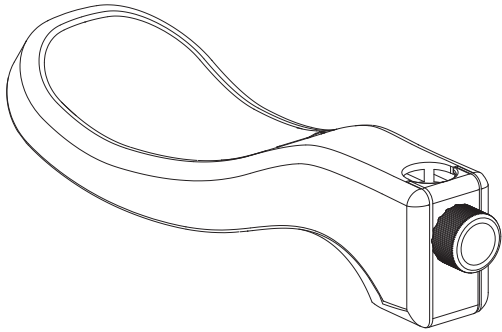

1 Turn the seat lock knob counterclockwise to remove from the seat clamp. Set seat lock knob aside.

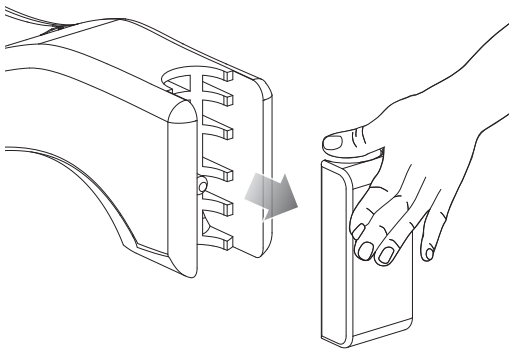

2 Pull seat clamp away from the seat. Set seat clamp aside.

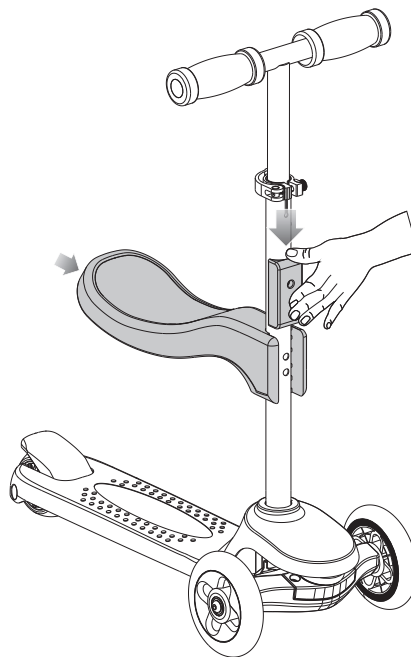

3 Align the seat with the square mounting holes on the steering tube. There are two possible positions for the seat, High and Low. Once seat is aligned slide the seat clamp onto the seat.

Need Help? Visit our website for replacement parts, product support, a list of authorized service centers in the US and customer service contact information at www.razor.com. Please have the product I.D. code (located on the white label of your product) available for better assistance. Additional Customer Service contact information is listed at the back of this manual.

ASSEMBLY AND SET-UP

□ Attaching the Seat (Continued)

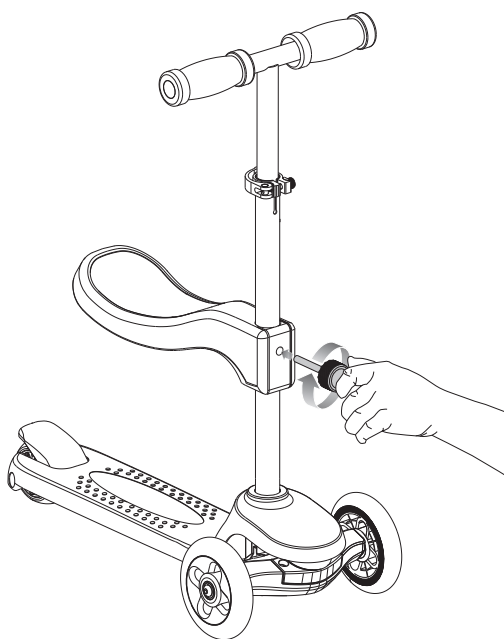

4 Insert the seat lock knob through the seat clamp and steer tube threading it into the seat turning clockwise to tighten.

□ Removing the Seat

Reverse steps 1-4 to remove the seat for stand up riding.

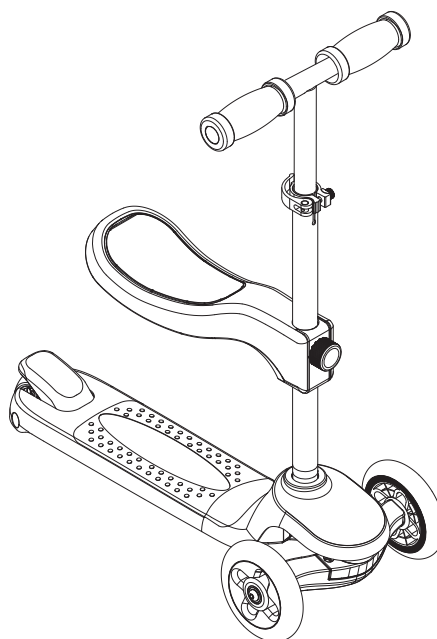

⚠ WARNING: Failure to properly install and tighten the seat may cause the rider to lose control and fall. If you do not understand these instructions, contact Razor customer care for assistance.

PRE-RIDE CHECKLIST



Deck and Handlebars

Check for cracks or broken connections. Although broken decks are rare, it is possible for an aggressive rider to run into a curb or object and wreck and bend or break the deck. Get in the habit of inspecting your scooter on a regular basis.



Hardware/Loose Parts

Check and secure all fasteners before every ride. Make sure the handlebars and seat (if installed) are locked properly in place before riding. There should not be any unusual rattles or sounds from loose parts or broken components. If the unit is damaged, do not ride. **Reference "Safety Warnings" on pages 1 and 2 of this manual.**



Safety Gear

Always wear proper protective gear, such as an approved safety helmet. Elbow pads and kneepads are recommended. Always wear closed toe shoes (lace-up with rubber soles) and keep shoelaces tied and out of the way of the wheels. **NEVER RIDE BAREFOOTED OR IN SANDALS..**



Laws and Regulations

Always check and obey any local laws or regulations.



Be Careful!

This product is not for aggressive or trick riding. Avoid steep inclines and don't ride too fast — you can lose control and fall. Skateboard parks are not designed for young riders. Never ride in traffic or on the street and watch your surroundings for pedestrians, bikers, boarders and skaters.

Maintain a hold on the handlebars at all times.

USAGE

SEATED RIDING

□ How to Ride

Make sure the seat is properly installed before seated riding. See pages 6-7 of this manual for seat assembly instructions. Make sure child is properly seated on scooter, with both hands on the handlebars. Child can start using their feet to propel themselves forward. A rider must be tall enough to walk the Rollie while sitting comfortably on the seat, putting both feet flat on the ground.

□ How to Stop

The rider stops the Rollie by placing both feet on the ground.

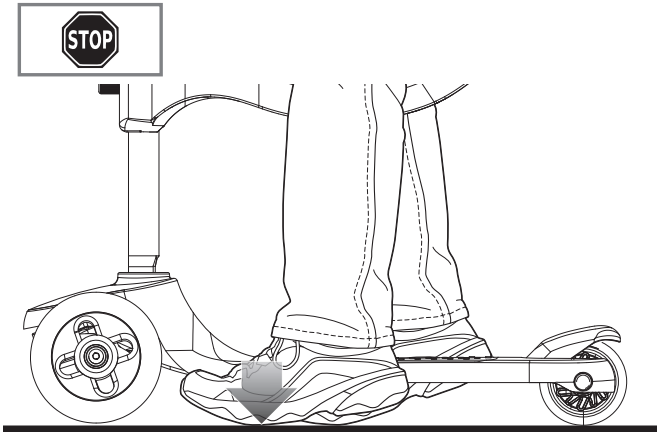

STAND-UP RIDING

□ How to Ride

Place one foot on the baseboard and push forward with the other foot. Ride with both hands on the handlebars. To turn, lean slightly in the desired direction. The "tilt-to-turn" front wheels and axle will cause the scooter to turn. Practice turning slowly in an open area free of fixed hazards.

□ How to Stop

For controlled stops, apply the brake by stepping on the rear-fender brake. Razor recommends you practice applying the brake in an open area free from obstructions before riding your scooter around others.

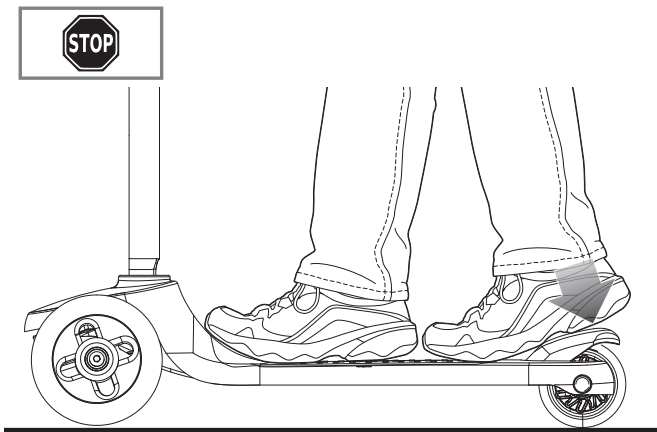

□ How to Operate Wheel Lights

- There is no power switch to activate the lights on the wheels.
- Wheel lights are activated when scooter is in motion.

□ How to Operate Deck Lights (Rollie DLX Models only)

- There is no power switch to activate the lights on the deck.
- The deck lights are activated by a vibration sensor.
- Deck lights are activated when scooter is in motion.
- Deck lights will remain on for approximately 20 seconds after scooter has stopped moving. Lights are re-activated when scooter resumes motion.

REPAIR AND MAINTENANCE

❑ **Cleaning**

Wipe with a damp cloth to remove dirt and dust. Do not use industrial cleaners or solvents, as they may damage the surfaces. Do not use alcohol, alcohol-based or ammonia-based cleaners, as they may damage or dissolve the plastic components or soften the decals or decal adhesive.

❑ **Wheels**

Under normal circumstances and conditions, Razor wheels are maintenance free. Nonetheless, it is the responsibility of the owner or guardian to periodically inspect the wheels for wear and tear, the axle for proper tightness, and for loose parts. When a wheel develops play, this is an indication of excess wear and replacement is necessary. Replace immediately with only genuine Razor wheels. Worn wheels are considered normal wear-and-tear and are not covered by the Razor Warranty. Wheels other than genuine Razor wheels may not be compatible with your Razor scooter. The use of anything other than genuine Razor replacement parts may affect your safety and will void your warranty.

❑ **Replacement Parts**

The most frequently requested replacement parts are available for purchase at some Razor retail partners. For the complete selection of replacement parts visit www.razor.com.

❑ **Repair Centers**

For a list of authorized Razor repair centers:

- Check online at www.razor.com.
- Additional Customer Service contact information is listed at the back of this manual.

ROLLIE/ROLLIE DLX PARTS

Keep your scooter working for years with genuine Razor parts. Visit our website or e-mail us for more information on spare part availability. (Specifications subject to change without notice.)

- | | | | |
|-------------------------------|--------------------|---------------------------|----------------------|
| 1. Handlebar Grips (Set of 2) | 6. Seat Clamp | 10. Truck | 15. Rear Axle Bolts |
| 2. T-Bar | 6-1 Seat Lock Knob | 11. Light-Up Front Wheels | 16. Front Axle Bolts |
| 3. Collar Clamp | 7. Pedal | 12. Rear Wheel | |
| 4. Seat Post | 8. Brake Pads | 13. Battery Tray | |
| 5. Seat | 9. Deck Plate | 14. AAA Batteries (x3) | |

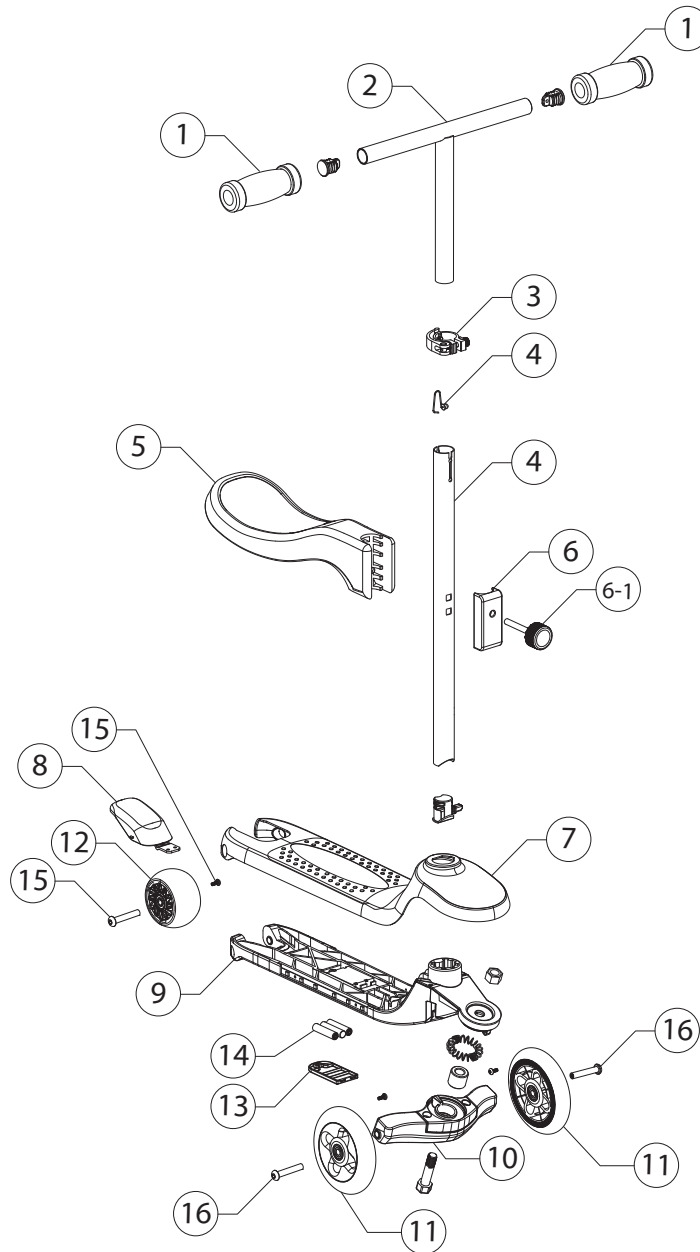

Need Help? Visit our website for replacement parts, product support, a list of authorized service centers in the US and customer service contact information at www.razor.com. Please have the product I.D. code (located on the white label of your product) available for better assistance. Additional Customer Service contact information is listed at the back of this manual.

WARRANTY

Razor Limited Warranty

The manufacturer warrants this product to be free of manufacturing defects for a period of 6 months from date of purchase. This Limited Warranty does not cover normal wear and tear, wheel, or any damage, failure or loss caused by improper assembly, maintenance, storage or use of the scooter.

This Limited Warranty will be void if the product is ever:

- used in a manner other than for recreation or transportation;
- modified in any way;
- rented.

The manufacturer is not liable for incidental or consequential loss or damage due directly or indirectly to the use of this product.

Razor does not offer an extended warranty. If you have purchased an extended warranty, it must be honored by the store at which it was purchased.

For your records, save your original sales receipt with this manual and write the serial number below.

CUSTOMER SERVICE CONTACT INFORMATION

Need Help? Visit our website for replacement parts, product support, a list of authorized service centers in the US and customer service contact information at www.razor.com. Please have the product I.D. code (located on the white label of your product) available for better assistance. Additional Customer Service contact information is listed below:

AMERICAS

Razor USA LLC
P.O. Box 3610
Cerritos, CA 90703
USA

+1 866 467 2967
Monday - Friday
8:00 AM - 5:00 PM Pacific Time
customersupport@razorusa.com

EUROPE, MIDDLE EAST, AFRICA

Razor USA LLC (Europe)
Handelsweg 2
2742 RD Waddinxveen
Netherlands

+44 (0) 120 267 2702
info@razoreu.com

ASIA

Razor USA LLC (Asia)
P.O. Box 3610
Cerritos, CA 90703
USA

+81 50 7579 6622
info@razor-asia.com

UNITED KINGDOM AND IRELAND

Razor USA LLC (UK)
Unit 20
Hartnoll Business Centre
Post Hill, Tiverton
Devon EX16 4NG
UK

+44 (0) 120 267 2702
info@razoreu.com

AUSTRALIA AND NEW ZEALAND

Razor USA LLC
P.O. Box 4280
Auburn South
VIC 3122
Australia

+1 800 954 354 (AU)
+0 800 003 221 (NZ)
info@razoranz.com

IMPORTED IN JAPAN BY B-PLUS ASIA CORP.

Razor USA LLC
THE RIRSTIK COMPANY
Kurokawa 3-1, Asaoku,
Kawasaki, Kanagawa
215-0035 JAPAN

+81 (0) 44 328 9057 Tel
+81 (0) 44 328 9067 Fax
info@razor-asia.com

Printed in China for Razor USA LLC.

Copyright © 2003-2022 Razor USA, LLC. All rights reserved. Razor® and the Razor logo design are among the registered trademarks of Razor USA LLC in the United States and/or select foreign countries. Rollie™, the Rollie logo design and the Rollie DLX logo design are trademarks of Razor USA LLC.