

Installation Instructions

SaltDogg® PRO Series Electric Drive Poly Hopper Spreader

U.S. Patents 9,562,333

Table of Contents

General Information	1
Safety Precautions	1
Installation Instructions	1-5
Spreader Operation	6
Spreader Maintenance	6-7
Repair Parts & Drawings	7-26
Warranty Information	28

General Information

SPREADER MODEL SERIES	OVERALL LENGTH	OVERALL WIDTH	OVERALL HEIGHT	EMPTY WEIGHT	CAPACITY STUCK
PRO1500	89.5"	48"	38"	647 lbs.	1.5 cu. yd.
PRO2000	96"	48"	44.3"	705 lbs.	2.0 cu. yd.
PRO2500	116.5"	48"	44.3"	986 lbs.	2.5 cu. yd.
PRO3000	125.7"	48.6"	46.1"	902 lbs.	3.0 cu. yd.
PRO4000	123.3"	77"	47.3"	812 lbs.	4.0 cu. yd.
PRO6000	136.3"	77"	57"	1,675 lbs.	6,0 cu. yd.

Vehicle Requirements

SPREADER MODEL SERIES	TRUCK MINIMUM GVWR	ALTERNATOR MINIMUM AMPS
PRO1500	8,500 lbs.	150 AMP
PRO2000	8,500 lbs.	150 AMP
PRO2500	13,000 lbs. (8 ft., bed)	150 AMP
PRO3000	13,000 lbs. (8 ft., bed)	150 AMP
PRO4000	15,000 lbs.	150 AMP
PRO6000	25,999 lbs.	150 AMP

Average Material Weights

This spreader is restricted to the use of dry, free-flowing salt, sand, and sand/salt mix. **Do not** run other materials through the spreader.

Materials to use	Weight (pounds per cubic yard)
Fine Salt-Dry	2,250
Coarse Salt-Dry	1,431
Sand/Salt up to 50/50 Mix-Dry	2,700

Note: To calculate the total spreader weight (including ice control material), add the empty spreader weight plus the ice control material and spreader accessories.

CAUTION

Do not overload vehicle beyond the vehicle's GVWR or GAWR. Check vehicle's load rating certification sticker for maximum vehicle capacity.

WARNING

Improper installation and operation could cause personal injury, and/or property damage. Observe the following Safety Precautions before, during and after operating this spreader. By following these precautions and common sense, possible injury to persons and potential damage to this machine may be avoided.

Safety Precautions

1. Read the entire Installation Instructions before operating or servicing this spreader.
2. Read and understand all safety decals on the spreader before operating.
3. Check to make sure all safety guards are securely mounted into place before operating this spreader.
4. Verify that all personnel are clear of the spreader spray area before starting or operating this spreader.
5. Do not over-load your vehicle beyond payload limits. If there are any questions, contact the vehicle manufacturer.
6. Do not adjust, clean, lubricate or unclog material jams without first turning off the spreader.
7. Do not climb on or in the spreader during operation. Do not ride on the spreader while the vehicle is in motion.
8. Make sure the spreader is securely fastened to the vehicle in accordance with this manual.
9. Do not operate a spreader that is in need of maintenance or repairs.
10. Do not operate the spreader while ill, tired, or under the influence of alcohol or drugs.
11. Batteries normally produce explosive gases which can cause personal injury. Always disconnect the battery before removing or replacing electrical components.
12. Do not leave unused material in hopper. Material can freeze or solidify, causing spreader to not work properly, and/or damage the unit. Empty and clean after each use.

Installation Instructions (PRO1500, 2000, 2500 Series)

1. Mounting the Spreader onto the Vehicle

- A. Remove the tailgate from the vehicle (if equipped) as well as any other object which will interfere with the spreader.
- B. Check truck's bed for all kinds of sharp debris or foreign objects. They can cut and seriously damage poly hopper.
- C. Remove chute, hardware kit from inside spreader. If spreader has been used make sure there is no material left in the hopper.
- D. Lift spreader using all tie downs (Fig. 1), or using fork lift. Lower spreader into the truck bed.

Fig. 1

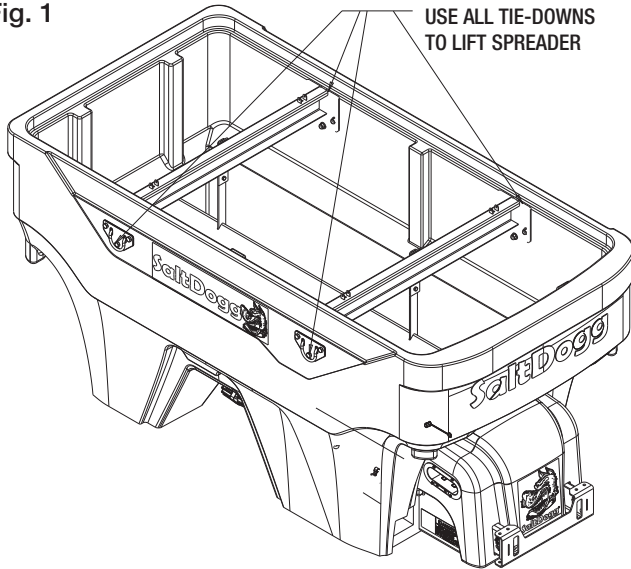

E. Center the spreader on the truck with the chute mount about 14" to the rear edge of the bed.

F. Chute assembly. Assemble chute to hopper following instructions shown in Fig. 2 – Fig. 3

Fig. 2

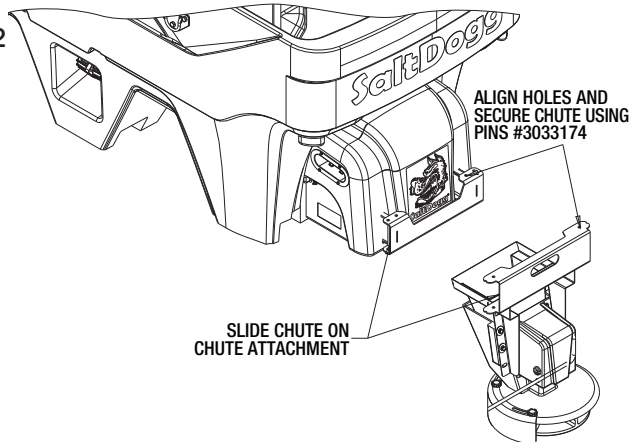
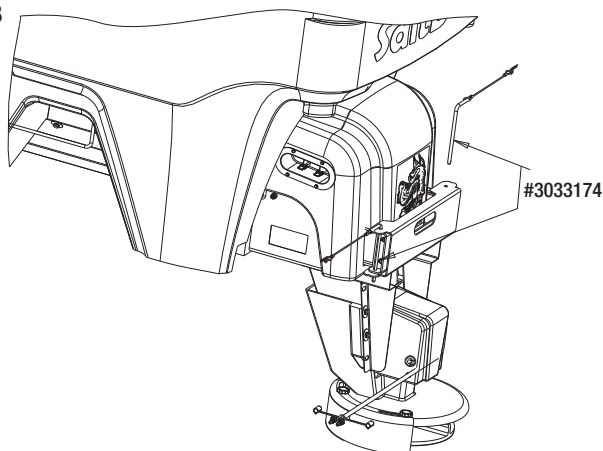
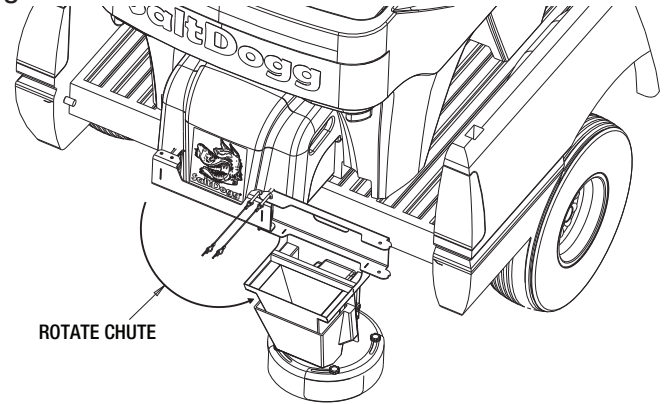

Fig. 3



G. Slide spreader forward or backwards to make sure that chute doesn't interfere with any part of the truck. Remove one pin and rotate chute as shown in Fig. 4. Make sure that chute doesn't hit any part of the truck.

Fig. 4



H. Measure the distance from the front of the truck bed to the front of the hoppers front legs. Fabricate spacer to fit between front of the spreader and front of the bed using 2 x 6 boards and install it between the spreader and truck bed front wall as shown in Fig. 5

Fig. 5

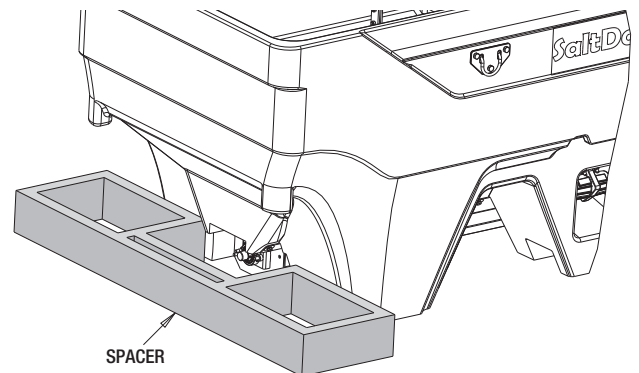
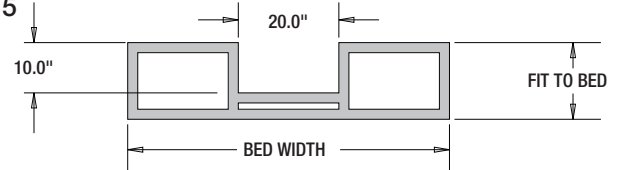

I. In addition, secure spreader using four ratchet straps. Tighten straps evenly. (Fig 5.1)

Fig. 5.1

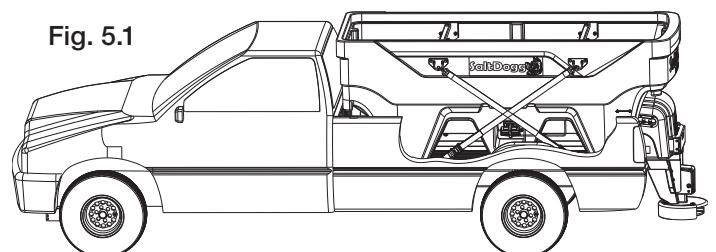

CAUTION

Inspect straps and hardware after each time spreader is loaded. Tighten straps and hardware if necessary.

WARNING

Important! Do not use ratchet straps or tailgate latch exclusively! Always use spacer!

Installation Instructions (PRO3000 Series)

1. Mounting the Spreader onto the Vehicle

- A.** Remove the tailgate from the vehicle (if equipped) as well as any other object which will interfere with the spreader.
- B.** Check truck's bed for all kinds of sharp debris or foreign objects. They can cut and seriously damage poly hopper.
- C.** Remove chute, hardware box from inside spreader. If spreader has been used make sure there is no material left in the hopper.

CAUTION

Never lift spreader with material in the hopper

- D.** Prepare 4 boards as shown in Figure 1. The board size is 2" x 6", 49" long minimum (cross boards from shipping pallet can be used). Boards can be as long as the inside width of trucks body.

Fig. 1

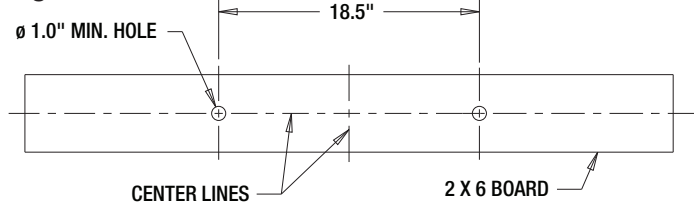

- E.** Next, set the spreader in the truck body. Use four tie-downs to lift the spreader (Figure 2). Rectangular openings on the bottom of support legs can also be used to lift spreader using forklift.

Fig. 2

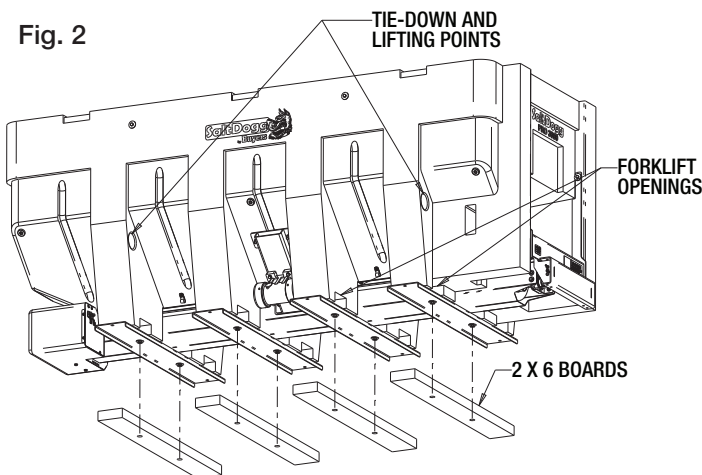

- F.** Lower spreader onto 2" x 6" boards positioned in truck bed. Make sure that bolt heads in stainless steel cross members would go into boards openings (Figure 1). Attach chute to the spreader (Figure 3). Remove one pin and rotate chute as shown in Figure 4. Make sure that chute doesn't hit any part of the truck in both positions. Adjust spreader forwards or backwards if needed for proper clearance.
- G.** Make sure the spreader is centered from side to side and rear legs rest fully on trucks body.
- H.** Using holes in cross members fasten spreader to the boards and vehicles body.

Fig. 3

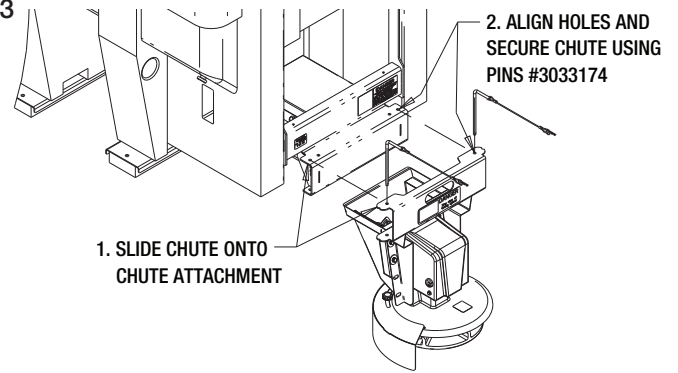
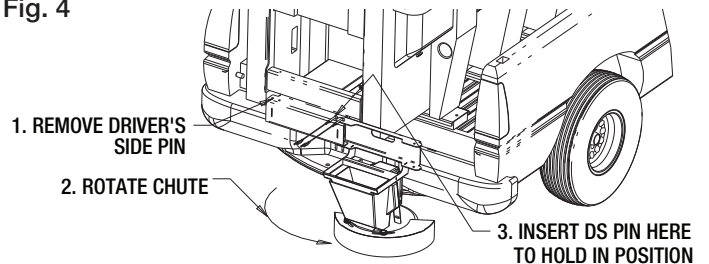

Fig. 4



- I.** Measure the distance from the front of the truck bed to the front of the hopper's front legs. Fabricate spacer to fit between front of the spreader and front of the bed using 2 x 8 boards and install it between the spreader and truck bed front wall as shown in Figure 5.
- J.** In addition, secure spreader using four ratchet straps. Attach straps to tie-downs. Tighten straps evenly.

WARNING

Important! Do not use ratchet straps or tailgate latch exclusively! Always fasten spreader to the vehicle!

CAUTION

Inspect straps and hardware after each time spreader is loaded. Tighten straps and hardware if necessary.

Fig. 5

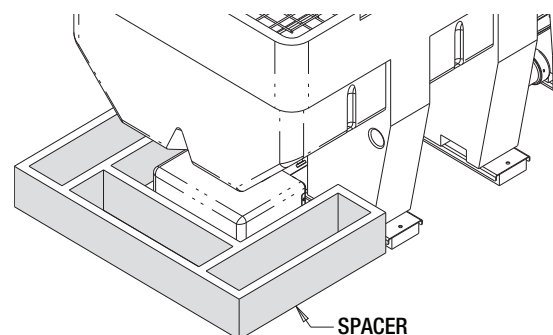
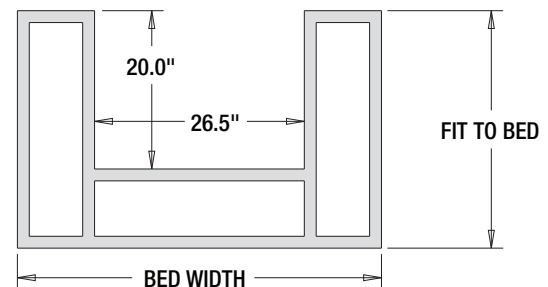

Installation Instructions (PRO4000 and PRO6000 Series)

Mounting The Spreader Onto the Vehicle

- A.** Remove the tailgate from the vehicle (if equipped) as well as any other object which will interfere with the spreader.
- B.** Check truck's bed for all kinds of sharp debris or foreign objects. They can cut and seriously damage poly hopper.
- C.** Remove chute, hardware kit from inside spreader. If spreader has been used make sure there is no material left in the hopper.
- D.** Prepare 4 boards as shown in Fig. 1. For the PRO4000 Series the board size is 2" x 4" x 60" long minimum. For the PRO6000 Series the board size is 2" x 4" x 70" long minimum. Boards can be as long as width of inside of trucks body.
- E.** Next, set the spreader in the truck body. Use four bars on the frame to lift the spreader (Fig. 1).

Fig 1. - PRO4000 Series

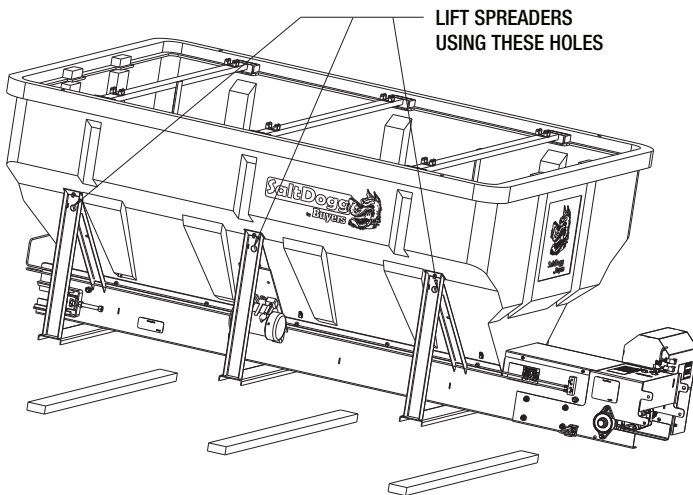
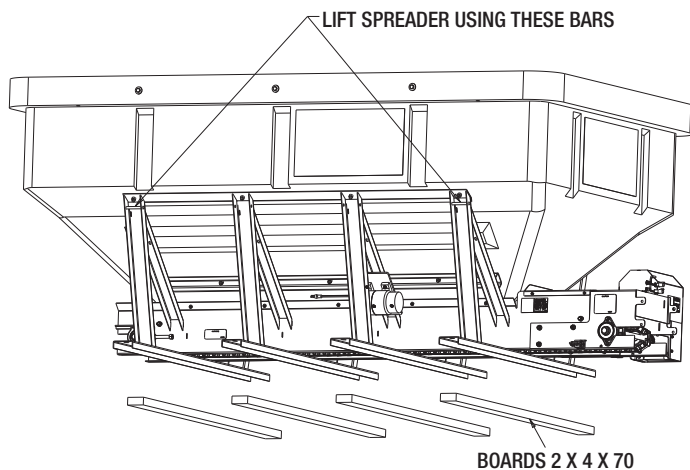

Fig. 1. - PRO6000 SERIES



- F.** Lower spreader onto 2" x 4" boards positioned in truck bed.
- G.** Center the spreader on the vehicle with the end of the gear mount 14" to the rear of the nearest vertical obstruction (bumper, trailer hitch, etc). Attach chute to spreader, check for interference between the vehicle and the Spinner/Chute Assembly.
- H.** Bolt the spreader to the vehicle frame through the lengths of lumber using the holes located in each of the four (4) cross members. Use 1/2" SAE Grade 5 hardware as required by vehicle application.
- I.** In addition, secure spreader using four ratchet straps or chain tie down kit (sold separately). Always tighten straps evenly!
 - The spreader must be securely fastened to the frame of the vehicle.
 - Verify with the vehicle's manufacturer that the factory installed anchor points are designed for tie-down of such load.
 - Periodically check that the spreader mounting hardware is securely tightened, retighten if necessary.

CAUTION

Never lift spreader with material in the hopper.

WARNING

Do not drill holes into fuel tanks, fuel lines, thru electrical wiring, etc that may be damaged by drilling.

CAUTION

Inspect straps and hardware after each time spreader is loaded. Tighten straps and hardware if necessary.

WARNING

Important! Do not use ratchet straps or tailgate latch exclusively! Always fasten spreader to the vehicle!

Control Box and Vehicle Wiring Harness Installation

Note: Make sure you have connected the proper wire color. This is a wire ground electrical system! No Connections to truck's frame or body allowed!

⚠ WARNING

Do not drill holes into fuel tanks, fuel lines, through electrical wiring, etc that may be damaged by drilling. To insure good performance of your spreader, check the condition of truck's electrical system. Using digital voltmeter, check alternator and battery voltage. With engine running and head lights and heater fan ON good voltage reading should fall between 13.0 and 15.3 volts. If voltage reading falls out of this range, check and adjust your electric system.

Note: Always disconnect battery before attempting to install electrical components on your vehicle

A. Mount the controller in a convenient location in the truck cab. It is recommended not to mount the controller directly in front of heat vents. Allow ample air space around controller

⚠ CAUTION

Do not mount controller in the way of air bag deployment!

- B.** Route both wire harnesses into truck cab through firewall (it maybe necessary to drill holes). Insulate hole to avoid water leaks.
- C.** Insure no wires are nicked or damaged during installation.
- D.** Connect the 4-pin connector on the wire harness to the control box 4-pin connector.
- E.** Connect the 2-pin connector on the power cable to the control box mating connector.
- F.** Connect wire harness single connectors to control box connectors.
- G.** Connect single wire with blade terminal to ignition switch or fuse, controlled by ignition switch. Newer controllers do not require ignition control, wire harness 0203700 should be discarded.

H. Lay out a path for the power cable to the battery, use quick ties to secure power cable. DO NOT CONNECT TO BATTERY AT THIS TIME!

I. Lay out path for wire harness to the rear of the vehicle. Stay clear of the exhaust system. Excess heat can damage the wire harnesses. Use quick ties to secure harness to underbody.

J. Connect the wire harness to the motors and vibrator. Make sure wire colors on wire harness match colors on the motor.

K. Thoroughly clean battery terminals. Make sure battery terminals have no tarnish or corrosion. DO NOT CONNECT WIRE HARNESS TO DAMAGED OR CORRODED TERMINALS! IT MAY RESULT IN OVERHEATING, LOST POWER AND POTENTIAL CONTROLLER DAMAGE! Install the circuit breaker within 12" from the battery. Connect red wire from cable 3035935 and battery cable 3001379 to circuit breaker according to the breaker markings. Connect the power cable and battery cable directly to the battery. Make sure connection to battery terminals is good and tight. Loose connection to battery terminals will result in sparking, overheating and possible battery damage!

L. Insure all functions of the controller are working properly.

M. Observe auger/ chain moving in proper direction. If direction is wrong reverse wires between Motor and Wire Harness.

N. Optional spot light (5 AMP max) can be installed on spreader. Use utility light kit part number 3018009. Remove cap from single brown capped wire. Connect light to this wire and the trucks frames known ground (negative).

⚠ IMPORTANT

Make sure all wires securely attached to vehicle or spreader. Use wire ties and/or wire clamps to attach wires. All excess wires must be rolled into bundles and attached to vehicle or spreader

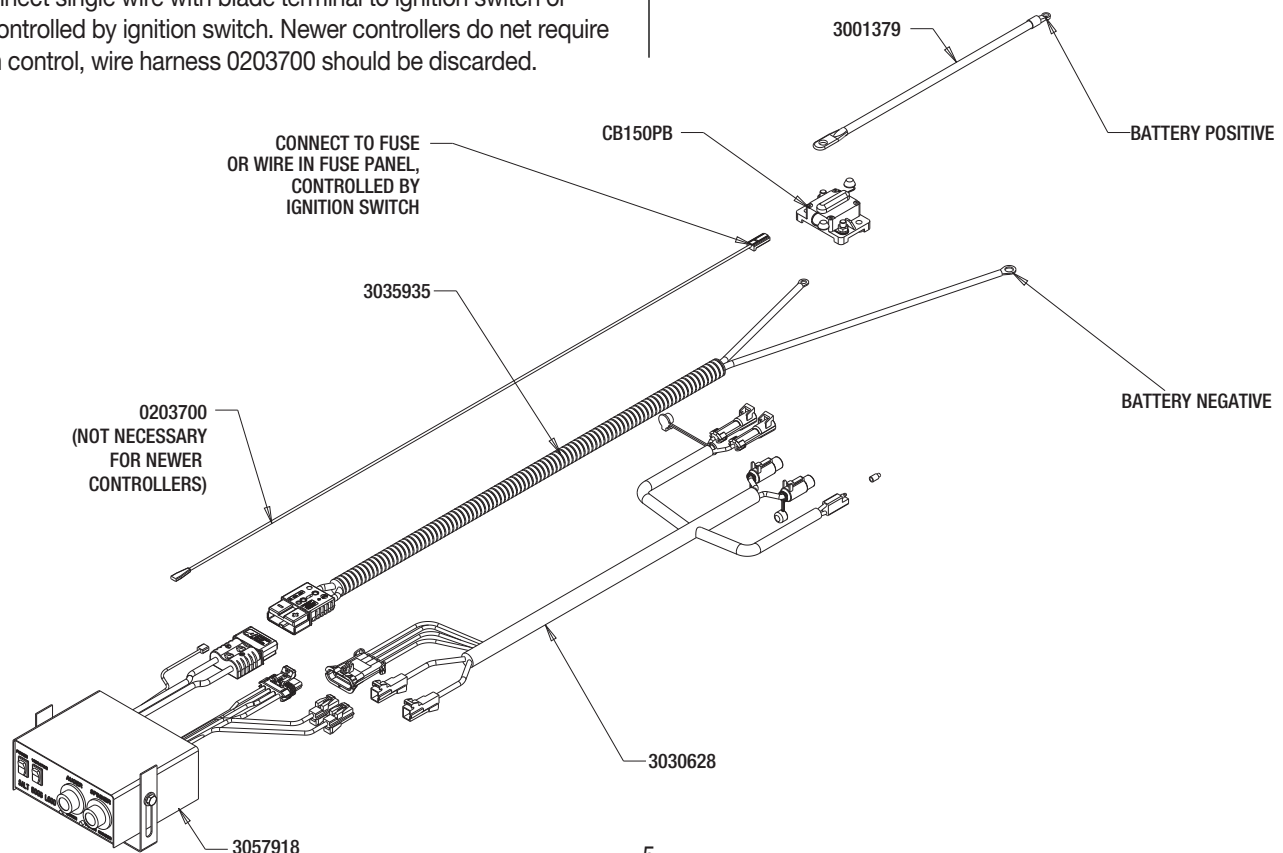

Spreader Operation

1. Spreader is equipped with a dual independent speed controller. To start spreader, press "POWER" switch. Switch will be illuminated. Auger/ chain and spinner will start rotating. Auger and spinner can be adjusted independently.
2. To activate vibrator press "VIBRATOR" switch, vibrator switch will illuminate. Vibrator can operate continuously for 30 min max with 15 min brakes to avoid overheating.
3. To stop spreader press "ON-OFF" switch again.
4. Spreader controller is equipped with electronic overload and current spike protection. Controller is not serviceable.
5. Spreading pattern can be controlled by repositioning of the baffles on the chute as shown in Fig. 6. Chute heights can be adjusted to accommodate different vehicle heights (Fig.6).

Fig. 6

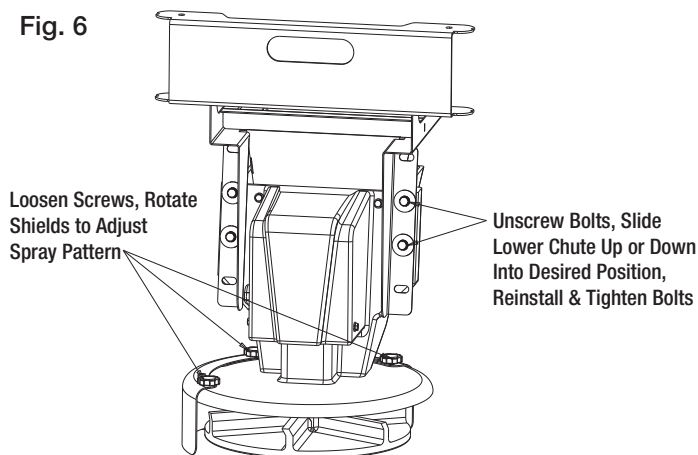

6. Check the Feed Chain tension periodically. To check the tension, measure in 21"-25" from the rear edge of the gear box mount. Push up on the chain with your hand. The conveyor chain should lift up 2"-3" off the conveyor chain guide or cross angles (Fig. 7).

Fig. 7

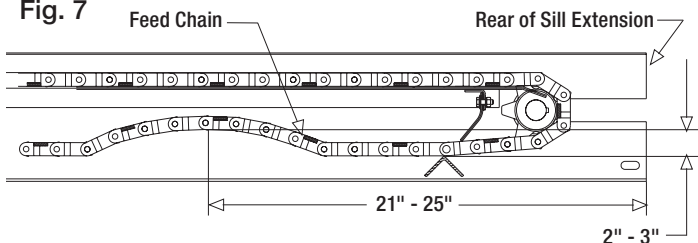

WARNING

Never attempt to lift spreader with material in hopper!

WARNING

Never leave material in hopper for extended period of time. Material can freeze, solidify and seriously damage the spreader

Spreader Materials

IMPORTANT

Only use dry salt, sand, sand/salt, or cinder/salt mixes in the spreader. Other materials could cause damage to the machine.

The density of materials that can be loaded into the spreader varies and therefore so will the amount of a given material that can be carried by the spreader before the maximum load rating is reached.

IMPORTANT

When filling the spreader, do not exceed the gross-vehicle-weight rating (GVWR) or gross-axle-weight rating (GAWR).

1. Ensure that the spreader is securely mounted to the vehicle and that the top screen is installed and secured in the hopper.
2. Remove the tarp, if used.
3. Determine the amount of material that you can safely transport using your vehicles GVWR/GAWR and the following table on page 1.
4. Fill the spreader evenly with your material, making sure not to fill past the top of the hopper.

IMPORTANT

Overfilling the hopper could damage the spreader & your vehicle.

Spreader Maintenance

1. Wash spreader after every use. Make sure no material is left under auger/ chain and/or inside trough.
2. Inspect and retighten fasteners after every 5-7 hours of operation.
3. Lubricate bearings every 7-10 hours of operation using general automotive grease.
4. Inspect terminals/connectors every time you disconnect spreader from wire harness. Apply thin layer of dielectric grease on terminals. If any tarnish/corrosion is found, clean terminals and apply dielectric grease.
5. Use dielectric grease on all electrical connectors before an electrical connection is made or after connector is disconnected
6. Empty the spreader of all ice control materials when not in use. Wash out the spreader to prevent material builds up.
7. It is recommended to cover spreader with the tarp during storage periods.

End of Season Maintenance

1. Wash spreader. Make sure no material or residue is left in and outside the hopper.
2. Lubricate bearing using general automotive grease.
3. Inspect wire harness, connectors for broken insulation, missing components. Replace if necessary.
4. Apply dielectric grease on all electrical connectors.
5. Store hopper indoors, in a dry, cool place.
6. Remove controller from truck. Store controller indoors, in a dry cool place.
7. Inspect wire near connectors. Check for broken or missing insulation. Check for tarnished or corroded wires. Trim corroded wires and replace connectors if necessary

Summer Storage

1. Apply dielectric grease or similar protective compound on all electrical connectors & protect them with caps before storage.
2. Disconnect and remove speed controller from vehicle and store it in dry and cool place. Protect controller from excessive heat and moisture.
3. Clean hopper and trough from all kinds of debris.
4. Remove, thoroughly lubricate and reinstall trough bearing.
5. Protect hopper from excessive temperatures during summer storage.

Accessories

PRO1500, PRO2000, and PRO3000 Series Spreaders are supplied with a tarp. To insure proper tarp operation, attach tarp to all hopper posts as shown in Fig. 8.

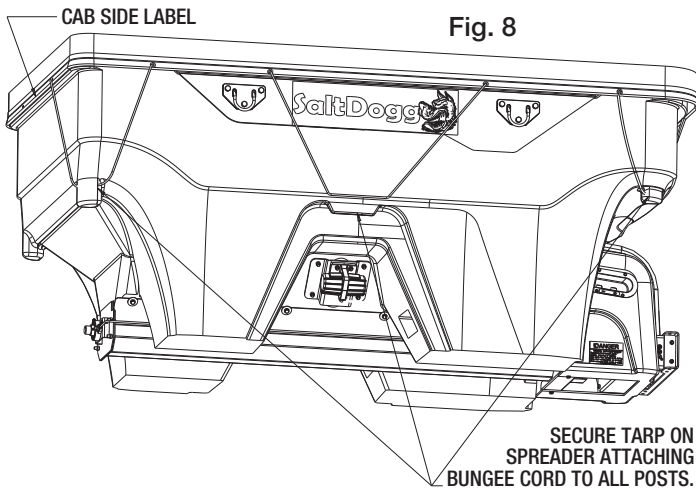

Connector Kit Drawing

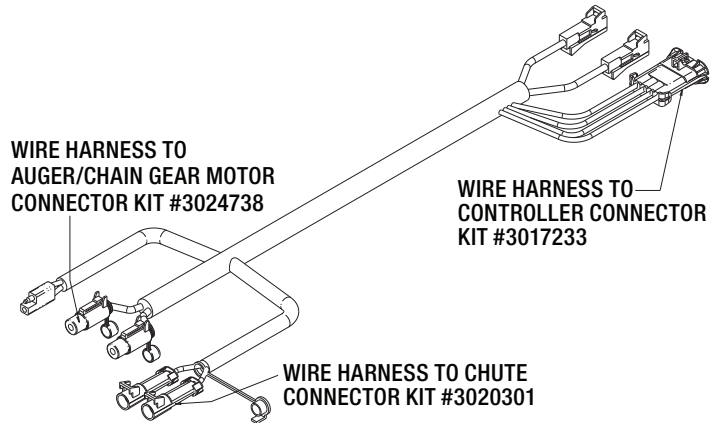

Repair Parts - Chute Assembly Part # 3031475

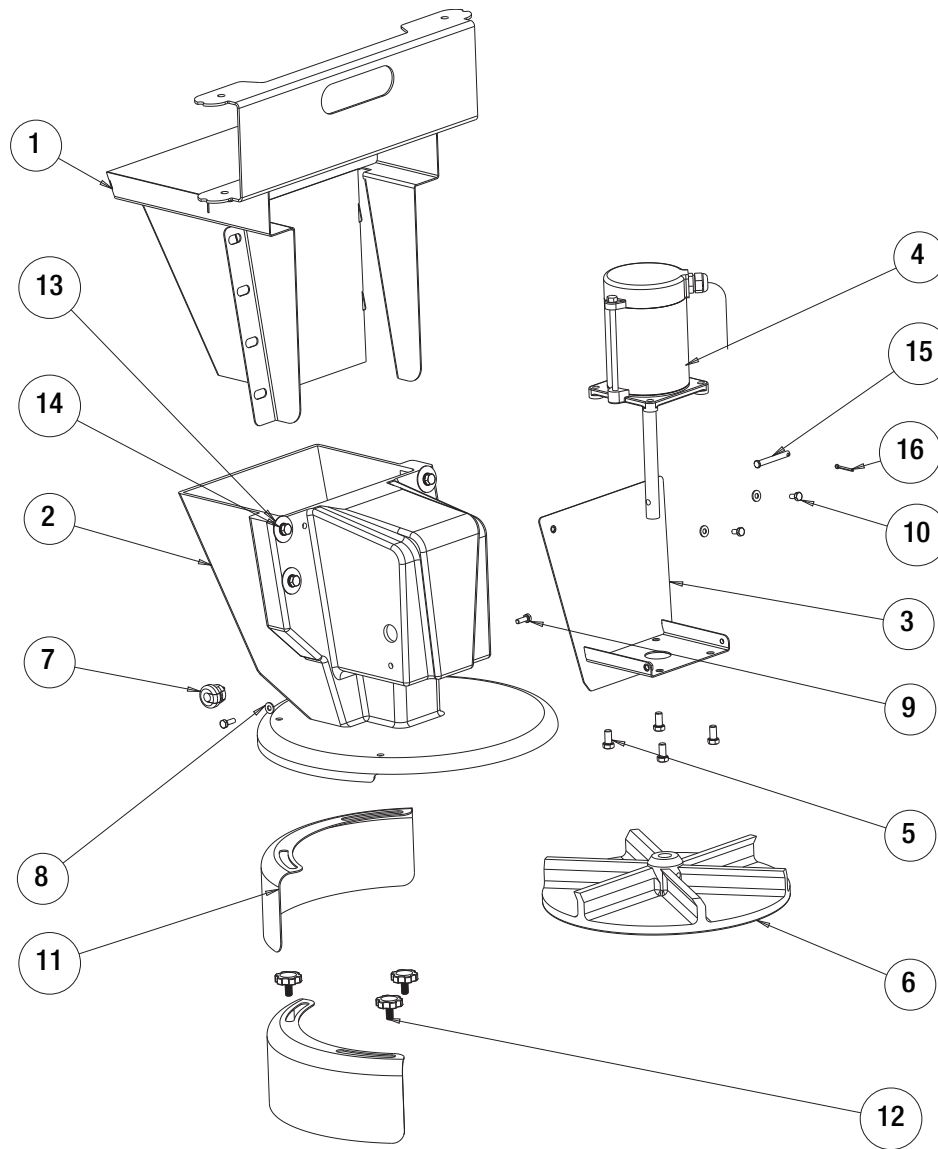

Bill of Materials

ITEM	PART NO.	QTY.	DESCRIPTION
1	3030868	1	UPPER CHUTE WELDMENT
2	3030930	1	CHUTE OUTER, POLY
3	3030908	1	MOTOR MOUNT CHUTE
4	3030907	1	MOTOR 12 VDC, .5 HP SPINNER
5	FCS038016075SS	8	SCREW, HHC-3/8-16 X 3/4 SST
6	3012393	1	SPINNER, 14" POLY CW
7	3025065	1	BUSHING STRAIN RELIEF
8	FWF025063007SS	4	WASHER, FLAT 1/4 SAE SS
9	FCS025020075SS	2	SCREW, CAP 1/4-20 X 3/4 SST
10	3008549	2	SCREW, HEXHD CAP 1/4-20X.5 SST
11	3030927	2	SHIELD, CHUTE
12	3031755	3	PLASTIC HEAD THUMB SCREW 3/8-16X3/4 SST
13	3007115	4	WASHER, FLAT 3/8 X 1.5 X.048 SST
14	FWL038069009SS	4	WASHER, LOCK RHS-3/8 SST
15	3007113	1	PIN, CLEVIS, 5/16 X 2-1/2, .141 HOLE ZN
16	3014994	1	PIN, COTTER, 1/8IN X 1IN SST

Repair Parts - PRO1500 Auger Hopper Assembly

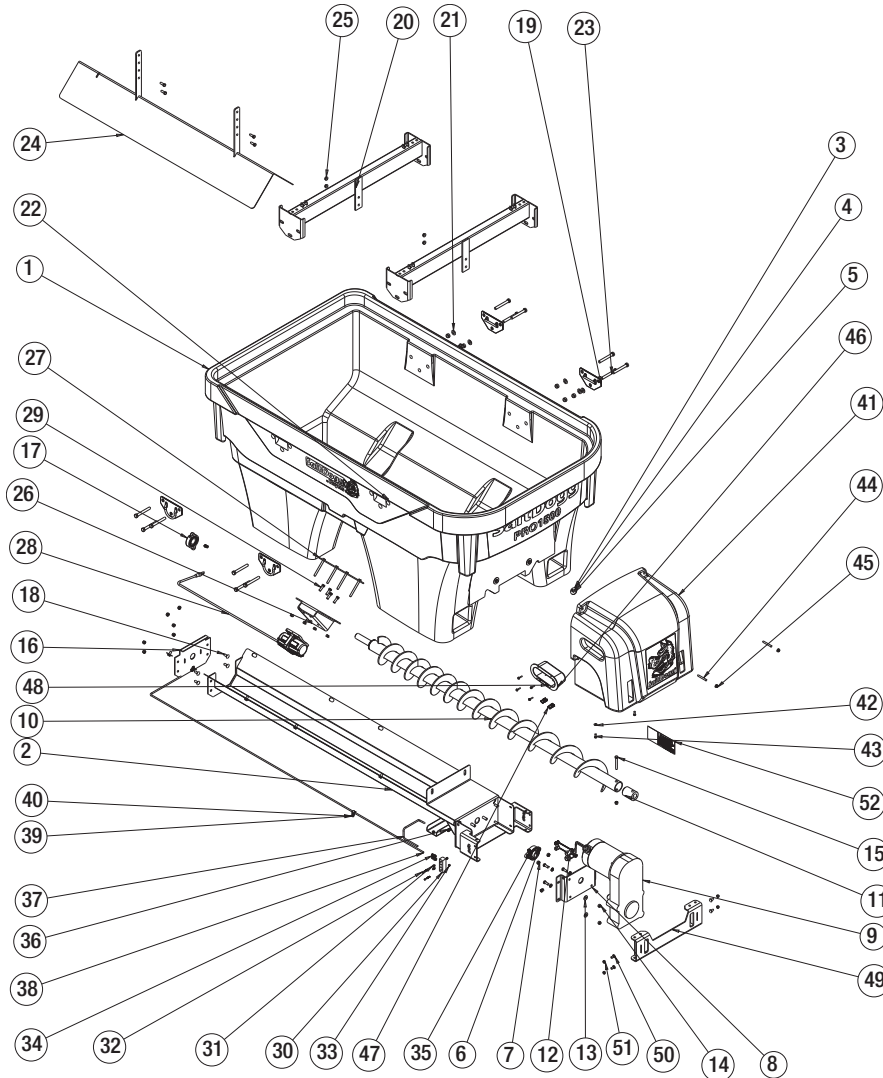

Bill of Materials

ITEM	PART NO.	QTY.	DESCRIPTION
1	3040940	1	HOPPER POLY PRO1500
2	3035261	1	TROUGH WELDMENT PRO2000
3	3007115	10	WASHER, FLAT 3/8 X 1.5 X.048 SST
4	FWL038069009SS	14	WASHER, LOCK RHS-3/8 SST
5	FCS038016075SS	10	SCREW, HHC-3/8-16 X 3/4 SST
6	1410200	1	BEARING, FLANGED 1-1/8"
7	3014756	4	NUT NYLOCK 7/16-14 SST
8	3033003	1	SPACER, GEAR MOTOR
9	3024575	1	GEAR MOTOR CONVEYOR 12 VDC
10	3035264	1	AUGER PRO2000 5.75 VARIABLE LH
11	3033663	1	SLEEVE, AUGER ADAPTER
12	FCS038016100SS	8	SCREW, HHC 3/8-16 X 1 304 SST
13	FWF038100007SS	4	WASHER, FLAT 3/8 USS SST
14	FNE038016044SS	17	NUT, NYLOCK 3/8-16 X 7/16 SST
15	3007068	1	CAP SCREW, HX HD-3/8-16X3 SST
16	3033070	1	BRACKET BEARING FRONT
17	9240086	1	BEARING, 1-1/4 FLANGE 2 HOLE
18	FCB037516100SS	4	BOLT, 3/8-16 X 1 CARRIAGE SST
19	3022220	4	TIE-DOWN WELDMENT
20	3041029	2	CROSS MEMBER
21	FWF050106010	12	WASHER, FLAT 1/2" SAE ZINC
22	FNE050013053	12	NUT, NYLOCK 1/2-13 ZINC
23	FCS050013400Z	12	SCREW, HEX HEAD CAP 1/2-13 X 4.00 GR 5 ZN
24	3041208	1	INVERTED VEE, PRO1500
25	3001255	4	NUT, HEX FLNG-3/8-16 SST
26	3039179	1	BRACKET, VIBRATOR
27	3034598	1	PLATE WELDMENT, VIBRATOR

ITEM	PART NO.	QTY.	DESCRIPTION
28	3007416	1	VIBRATOR 200 LBS 12 VDC
29	FCS038016125SS	4	SCREW, HHC-3/8-16 X 1.25 SST
30	3035346	1	RIGHT ANGLE JUNCTION BLOCK
31	800	2	GREASE FITTING, 1/4 STD
32	3035357	2	SCREW SOCKET HD, RND 8-32X 1.50 SST
33	3035358	2	NUT, NYLOCK 8-32 SST, BLACK OXIDE
34	3035347	2	GREASE FITTING 1/4TUBE 1/8 NPT STRAIGHT
35	3035344	2	GREASE FITTING 1/4TUBE 1/4-28 MALE STRAIGHT
36	3035742	2	BUSHING SNAP THICK PANEL
37	3035359	1	GREASE TUBE REAR BEARING AUGER
38	3035360	1	GREASE TUBE FRONT BEARING AUGER
39	4375	2	CLAMP, HOSE .4375, 9/32 HOLE
40	3007522	6	SCREW, SHEET MTL #12x1.0 HEX WASHER HD SST
41	3031169	1	SHROUD
42	FWF025063007SS	2	WASHER, FLAT 1/4 SAE SS
43	FCS025020075SS	2	SCREW, CAP 1/4-20 X 3/4 SST
44	3033165	2	STUD THREADED 5/16-18 X 2.5 SST
45	3006719	2	NUT, HEX FLANGE - 5/16-18 SS
46	3031203	1	MOUNT CONNECTORS
47	3031276	2	CLIP ATTACHMENT, CONNECTOR DEUTSCH
48	3033172	1	DECAL CONNECTION
49	3033076	1	CHUTE ATTACHMENT
50	3012144	4	BOLT, CARRIAGE, 5/16-18 X 1 SST
51	FNE031018034SS	4	NUT, NYLOCK 5/16-18 SS
52	3032591	1	DECAL, DANGER, MOVING CONVEYOR/ AUGER

Repair Parts - PRO1500CH Chain Hopper Assembly

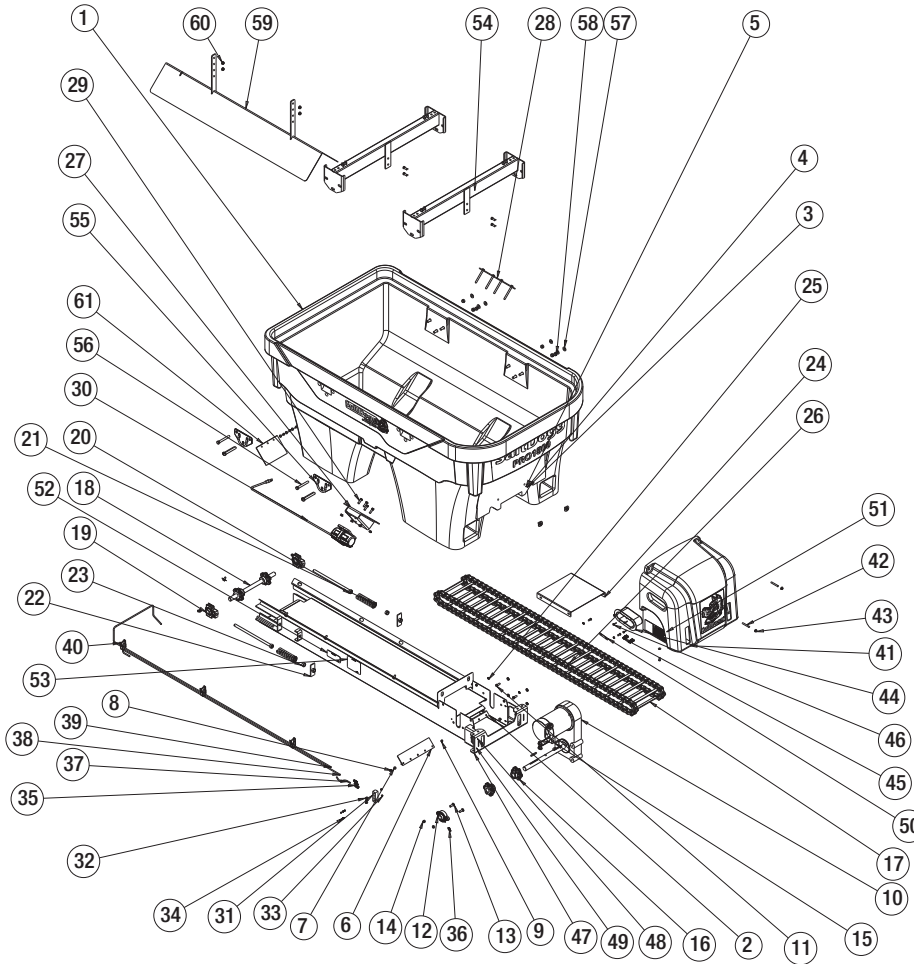

Bill of Materials

ITEM	PART NO.	QTY.	DESCRIPTION
1	3040940	1	HOPPER POLY PRO1500
2	3034593	1	TROUGH WELDMENT CHAIN PRO2000
3	3007115	10	WASHER, FLAT 3/8 X 1.5 X.048 SST
4	FWL038069009SS	14	WASHER, LOCK RHS-3/8 SST
5	FCS038016075SS	10	SCREW, HHC-3/8-16 X 3/4 SST
6	1410241	1	WIPER BELT, HOPPER
7	FWF025063007SS	10	WASHER, FLAT 1/4 SAE SS
8	3008549	5	SCREW, HEXHD CAP 1/4-20X.5 SST
9	FNE025020031SS	5	NUT, NYLON INSERT 1/4-20 SST
10	3013821	1	GEAR MOTOR CONVEYOR 12 VDC
11	FCS038016100SS	8	SCREW, HHC 3/8-16 X 1 304 SST
12	1410200	1	BEARING, FLANGED 1-1/8"
13	3031483	2	BOLT, 3/8-16 X 1 CARRIAGE SHORT NECK SST
14	FNE038016044SS	10	NUT, NYLOCK 3/8-16X7/16 SST
15	KS402	2	KEY, 1/4 X 1/4X2
16	1410250	2	SPROCKET, 6 TOOTH PINTLE CHAIN
17	1401300	1	CHAIN, CONVEYOR. D662 93 LINKS
18	3008571	1	SHAFT IDLER, ASSEMBLY
19	1411001	2	BEARING, IDLER TAKE UP
20	3023046	2	BOLT, WELDED TAKE UP
21	3023022	2	SPRING CHAIN TENSION
22	3031199	2	TAKE-UP NUT WELDMENT
23	FNH063011054SS	2	NUT, HH 5/8-11 X 17/32 HIGH SST
24	3031195	1	CHAIN COVER
25	FWL025050006SS	4	WASHER, 1/4 IN. SPRING LOCK SST
26	FCS025020075SS	9	SCREW, CAP 1/4-20 X 3/4 SST
27	3039179	1	BRACKET, VIBRATOR
28	3034598	1	PLATE WELDMENT, VIBRATOR
29	FCS038016125SS	4	SCREW, HHC-3/8-16 X 1.25 SST
30	3007416	1	VIBRATOR 200 LBS 12 VDC
31	3035346	1	RIGHT ANGLE JUNCTION BLOCK
32	800	3	GREASE FITTING, 1/4 STD

ITEM	PART NO.	QTY.	DESCRIPTION
33	3035358	2	NUT, NYLOCK 8-32 SST, BLACK OXIDE
34	3035357	2	SCREW SOCKET HD, RND 8-32X 1.50 SST
35	3035347	3	GREASE FITTING 1/4TUBE 1/8 NPT STRAIGHT
36	3035344	3	GREASE FITTING 1/4TUBE 1/4-28 MALE STRAIGHT
37	3035348	1	GREASE HOSE REAR BEARING
38	3035355	1	GREASE HOSE FRONT DR SIDE
39	3035356	1	GREASE HOSE FRONT PS SIDE
40	5000	3	HOSE CLAMP, .375 DIA
41	3031169	1	SHROUD
42	3033165	2	STUD THREADED 5/16-18 X 2.5 SST
43	3006719	2	NUT, HEX FLANGE-5/16-18 SS
44	3031203	1	MOUNT CONNECTORS
45	3031276	2	CLIP ATTACHMENT, CONNECTOR DEUTSCH
46	3007522	7	SCREW, SHEET MTL #12x1.0 HEX WASHER HD SST
47	3033076	1	CHUTE ATTACHMENT
48	3012144	4	BOLT, CARRIAGE, 5/16-18 X 1 SST
49	FNE031018034SS	4	NUT, NYLOCK 5/16-18 SS
50	3033172	1	DECAL CONNECTION
51	3032591	1	DECAL, DANGER, MOVING CONVEYOR/AUGER
52	1499035	1	LABEL, WARNING 3
53	1499030	1	LABEL, CAUTION 1 (PAYLOAD)
54	3041029	2	CROSS MEMBER
55	3022220	4	TIE-DOWN WELDMENT
56	FCS050013400Z	12	SCREW, HEX HEAD CAP 1/2-13X4.00 GR5ZN
57	FWF050106010	12	WASHER, FLAT 1/2" SAE ZINC
58	FNE050013053	12	NUT, NYLOCK 1/2-13 ZINC
59	3041208	1	INVERTED VEE, PRO1500
60	3001255	4	NUT, HEXFLNG-3/8-16SST
61	3043864	1	WIPER BELT, FRONT

Repair Parts - PRO1500 Spreader

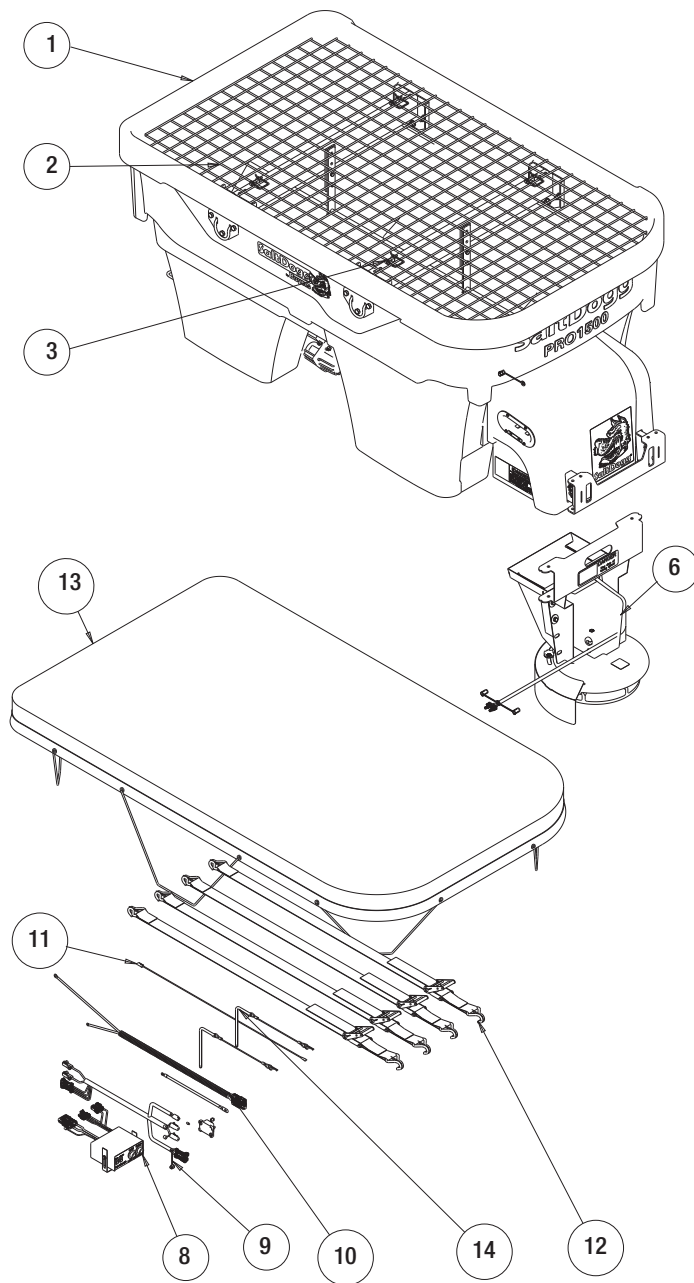

Bill of Materials

ITEM	PART NO.	QTY.	DESCRIPTION
1	3043781	1	HOPPER ASSEMBLY AUGER
2	3041211	1	TOP SCREEN PRO1500
3	66050	4	SNAPPER PIN, 1/4 X 2, YLW ZINC
4	3043775	1	LABEL SERIAL NUMBER PRO1500
5	3035854	1	LABEL PATENT
6	3031475	1	CHUTE SWING ADJ
7	3043772	1	HARDWARE KIT PRO1500
8	3057918	1	CONTROLLER SPEED 12 VDC, 60 AMP
9	3030628	1	WIRE HARNESS MAIN
10	3035938	1	KIT POWER CABLE REPLACES 3016943
11	0203700	1	WIRE ASSEMBLY, 36 LONG
12	1496505	1	HOLD DOWN KIT, SPREADER (4 STRAPS)
13	3043774	1	TARP PRO1500
14	3033174	2	PIN, CHUTE ATTACHMENT

Repair Parts - PRO1500CH Spreader

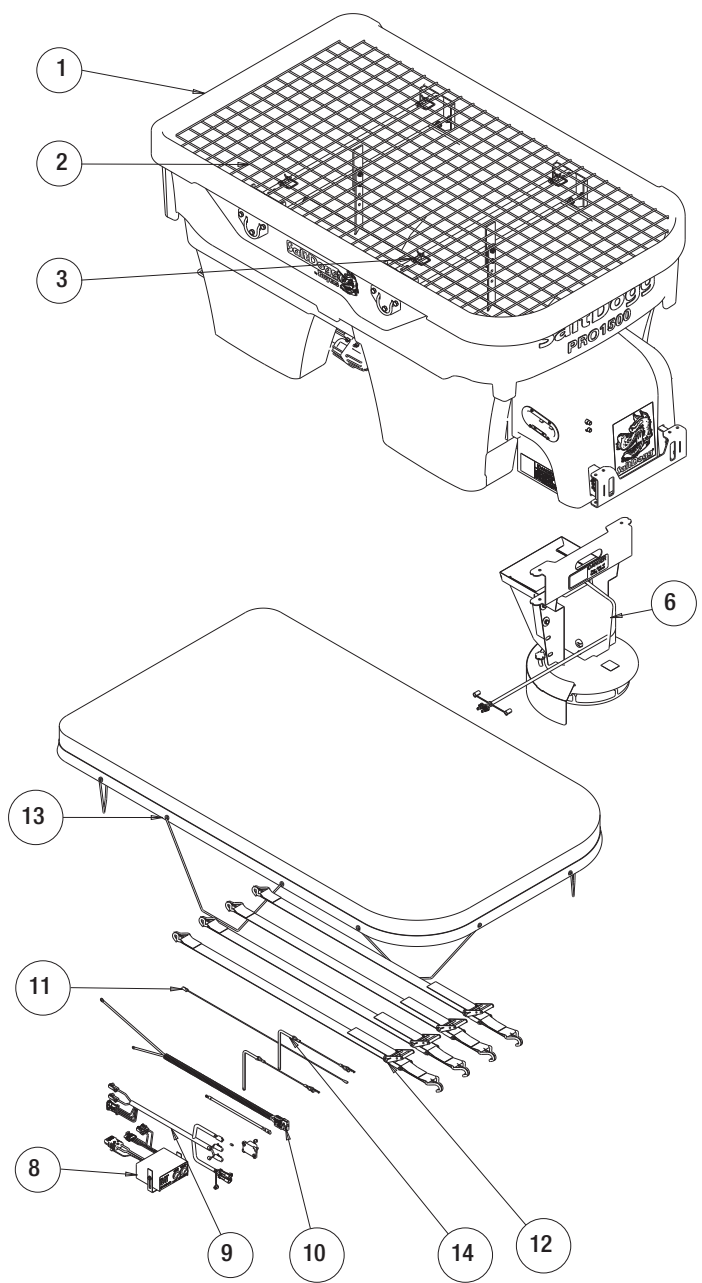

Bill of Materials

ITEM	PART NO.	QTY.	DESCRIPTION
1	3040941	1	HOPPER ASSEMBLY CHAIN
2	3041211	1	TOP SCREEN PRO1500
3	66050	4	SNAPPER PIN, 1/4 X 2, YLW ZINC
4	3043775	1	LABEL SERIAL NUMBER PRO1500
5	3035854	1	LABEL PATENT
6	3031475	1	CHUTE SWING ADJ
7	3043772	1	HARDWARE KIT PRO1500
8	3057918	1	CONTROLLER SPEED 12 VDC, 60 AMP
9	3030628	1	WIRE HARNESS MAIN
10	3035938	1	KIT POWER CABLE REPLACES 3016943
11	0203700	1	WIRE ASSEMBLY, 36 LONG
12	1496505	1	HOLD DOWN KIT, SPREADER (4 STRAPS)
13	3043774	1	TARP PRO1500
14	3033174	2	PIN, CHUTE ATTACHMENT

Repair Parts - PRO2000 Auger Hopper Assembly

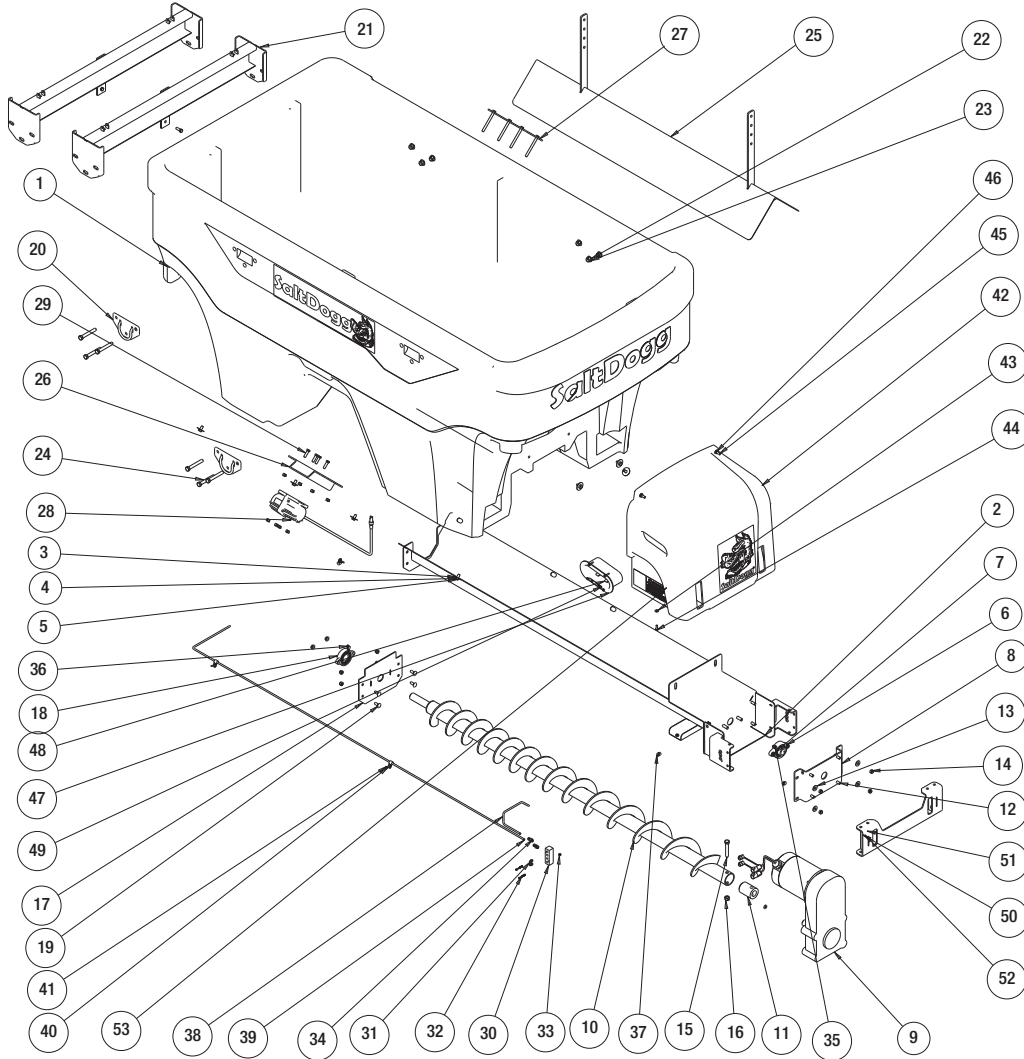

Bill of Materials

ITEM	PART NO.	QTY.	DESCRIPTION
1	3034401	1	HOPPER PRO20000
2	3035261	1	TROUGH WELDMENT PRO20000
3	3007115	10	WASHER, FLAT 3/8 X 1.5 X.048 SST
4	FWL038069009SS	14	WASHER, LOCK RHS-3/8 SST
5	FCS038016075SS	10	SCREW, HHC-3/8-16 X 3/4 SST
6	1410200	1	BEARING, FLANGED 1-1/8"
7	3001255	8	NUT, HEX FLNG-3/8-16 SST
8	3033003	1	SPACER, GEAR MOTOR
9	3024575	1	GEAR MOTOR CONVEYOR 12 VDC
10	3035264	1	AUGER PRO20000 5.75 VARIABLE LH
11	3033663	1	SLEEVE, AUGER ADAPTER
12	FCS038016100SS	8	SCREW, HHC 3/8-16 X 1 304 SST
13	FWF038100007SS	4	WASHER, FLAT 3/8 USS SST
14	FNE038016044SS	16	NUT, NYLOCK 3/8-16 X 7/16 SST
15	3001250	1	SCREW, HHC-1/2-13 X 3 SST
16	FNE050013053SS	1	NUT, NYLOCK 1/2-13 SS
17	3033070	1	BRACKET BEARING FRONT
18	9240086	1	BEARING, 1-1/4 FLANGE 2 HOLE
19	FCB037516100SS	4	BOLT, 3/8-16 X 1 CARRIAGE SST
20	3022220	4	TIE-DOWN WELDMENT
21	3035740	2	CROSS MEMBER
22	FWF050106010	12	WASHER, FLAT 1/2" SAE ZINC
23	FNE050013053	12	NUT, NYLOCK 1/2-13 ZINC
24	3005140	12	SCREW, HH1/2-13 x 3.5, GR 5 ZN
25	3035267	1	INVERTED VEE, PRO20000
26	3039179	1	BRACKET VIBRATOR
27	3034598	1	PLATE WELDMENT, VIBRATOR

ITEM	PART NO.	QTY.	DESCRIPTION
28	3007416	1	VIBRATOR 200 LBS 12 VDC
29	FCS038016125SS	4	SCREW, HHC-3/8-16 X 1.25 SST
30	3035346	1	RIGHT ANGLE JUNCTION BLOCK
31	800	2	GREASE FITTING, 1/4 STD
32	3035357	2	SCREW SOCKET HD, RND 8-32X 1.50 SST
33	3035358	2	NUT, NYLOCK 8-32 SST, BLACK OXIDE
34	3035347	2	GREASE FITTING 1/4TUBE 1/8 NPT STRAIGHT
35	3035344	1	GREASE FITTING 1/4TUBE 1/4-28 MALE STRAIGHT
36	3035345	1	GREASE FITTING 1/4TUBE 1/4-28 MALE 90 DEGREES
37	3035742	2	BUSHING SNAP THICK PANEL
38	3035359	1	GREASE TUBE REAR BEARING AUGER
39	3035360	1	GREASE TUBE FRONT BEARING AUGER
40	4375	3	CLAMP, HOSE .4375, 9/32 HOLE
41	3007522	7	SCREW, SHEET MTL #12x1.0 HEX WASHER HD SST
42	3031169	1	SHROUD
43	FWF025063007SS	2	WASHER, FLAT 1/4 SAE SS
44	FCS025020075SS	2	SCREW, CAP 1/4-20 X 3/4 SST
45	3033165	2	STUD THREADED 5/16-18 X 2.5 SST
46	3006719	2	NUT, HEX FLANGE - 5/16-18 SS
47	3031203	1	MOUNT CONNECTORS
48	3031276	2	CLIP ATTACHMENT, CONNECTOR DEUTSCH
49	3033172	1	DECAL CONNECTION
50	3033076	1	CHUTE ATTACHMENT
51	3012144	4	BOLT, CARRIAGE, 5/16-18 X 1 SST
52	FNE031018034SS	4	NUT, NYLOCK 5/16-18 SS
53	3032591	1	DECAL, DANGER, MOVING CONVEYOR/ AUGER

Repair Parts - PRO2000CH Chain Hopper Assembly

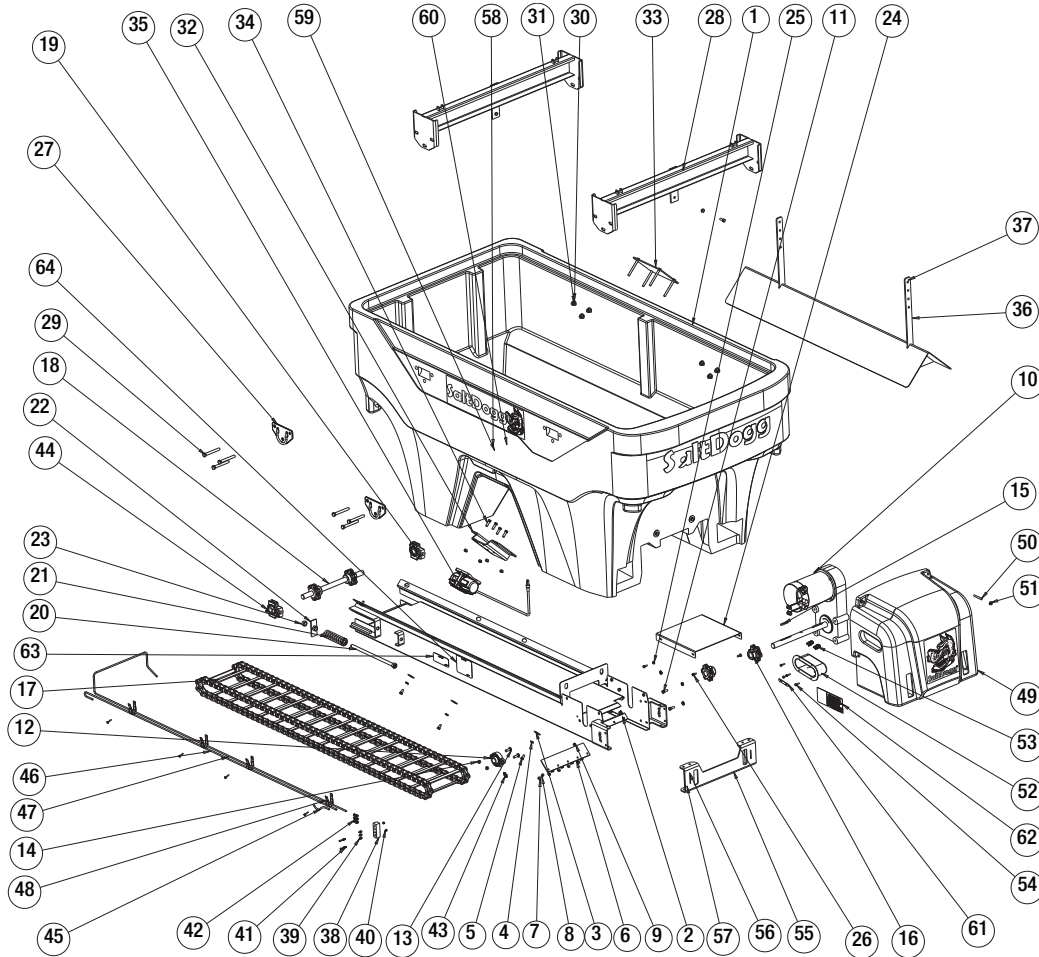

Bill of Materials

ITEM	PART NO.	QTY.	DESCRIPTION
1	3034401	1	HOPPER PRO20000
2	3034593	1	TROUGH WELDMENT CHAIN PRO20000
3	3007115	10	WASHER, FLAT 3/8 X 1.5 X.048 SST
4	FWL038069009SS	14	WASHER, LOCK RHS-3/8 SST
5	FCS038016075SS	10	SCREW, HHC-3/8-16 X 3/4 SST
6	1410241	1	WIPER BELT, HOPPER
7	FWF025063007SS	7	WASHER, FLAT 1/4 SAE SS
8	3008549	5	SCREW, HEXHD CAP 1/4-20X.5 SST
9	FNE025020031SS	5	NUT, NYLON INSERT 1/4-20 SST
10	3013821	1	GEAR MOTOR CONVEYOR 12 VDC
11	FCS038016100SS	8	SCREW, HHC 3/8-16 X 1 304 SST
12	1410200	1	BEARING, FLANGED 1-1/8"
13	3031483	2	BOLT, 3/8-16 X 1 CARRIAGE SHORT NECK SST
14	FNE038016044SS	10	NUT, NYLOCK 3/8-16 X 7/16 SST
15	KS402	2	KEY, 1/4 X 1/4 X 2
16	1410250	2	SPROCKET, 6 TOOTH PINTLE CHAIN
17	1401300	1	CHAIN, CONVEYOR. D662 93 LINKS
18	3008571	1	SHAFT IDLER, ASSEMBLY
19	1411001	2	BEARING, IDLER TAKE UP
20	3023046	2	BOLT, WELDED TAKE UP
21	3023022	2	SPRING CHAIN TENSION
22	3031199	2	TAKE-UP NUT WELDMENT
23	FNH063011054SS	2	NUT, HH 5/8-11 X 17/32 HIGH SST
24	3031195	1	CHAIN COVER
25	FWL025050006SS	4	WASHER, 1/4 IN. SPRING LOCK SST
26	FCS025020075SS	6	SCREW, CAP 1/4-20 X 3/4 SST
27	3022220	4	TIE-DOWN WELDMENT
28	3035740	2	CROSS MEMBER
29	FCS050013400Z	12	SCREW, HEX HEAD CAP 1/2-13 X 4.00 GR 5 ZN
30	FWF050106010	12	WASHER, FLAT 1/2" SAE ZINC
31	FNE050013053	12	NUT, NYLOCK 1/2-13 ZINC
32	3039179	1	BRACKET VIBRATOR

ITEM	PART NO.	QTY.	DESCRIPTION
33	3034598	1	PLATE WELDMENT, VIBRATOR
34	FCS038016125SS	4	SCREW, HHC-3/8-16 X 1.25 SST
35	3007416	1	VIBRATOR 200 LBS 12 VDC
36	3035267	1	INVERTED VEE, PRO20000
37	3001255	4	NUT, HEX FLNG-3/8-16 SST
38	3035346	1	RIGHT ANGLE JUNCTION BLOCK
39	800	3	GREASE FITTING, 1/4 STD
40	3035358	2	NUT, NYLOCK 8-32 SST, BLACK OXIDE
41	3035357	2	SCREW SOCKET HD, RND 8-32X 1.50 SST
42	3035347	3	GREASE FITTING 1/4TUBE 1/8 NPT STRAIGHT
43	3035344	1	GREASE FITTING 1/4TUBE 1/4-28 MALE STRAIGHT
44	3035345	2	GREASE FITTING 1/4TUBE 1/4-28 MALE 90°
45	3035348	1	GREASE HOSE REAR BEARING
46	3035355	1	GREASE HOSE FRONT DR SIDE
47	3035356	1	GREASE HOSE FRONT PS SIDE
48	5000	4	HOSE CLAMP, .375 DIA
49	3031169	1	SHROUD
50	3033165	2	STUD THREADED 5/16-18 X 2.5 SST
51	3006719	2	NUT, HEX FLANGE - 5/16-18 SS
52	3031203	1	MOUNT CONNECTORS
53	3031276	2	CLIP ATTACHMENT, CONNECTOR DEUTSCH
54	3007522	8	SCREW, SHEET MTL #12X1.0 HEX WASHER HD SST
55	3033076	1	CHUTE ATTACHMENT
56	3012144	4	BOLT, CARRIAGE, 5/16-18 X 1 SST
57	FNE031018034SS	4	NUT, NYLOCK 5/16-18 SS
58	3033164	1	WIPER BRACKET
59	3035269	1	WIPER BELT, FRONT
60	3015873	5	SCREW #12-14x.74 SS SELF DRIL HEX WASHER HD
61	3033172	1	DECAL CONNECTION
62	3032591	1	DECAL, DANGER, MOVING CONVEYOR/ AUGER
63	1499035	1	LABEL, WARNING 3
64	1499030	1	LABEL, CAUTION 1 (PAYLOAD)

Repair Parts - PRO2000 Spreader

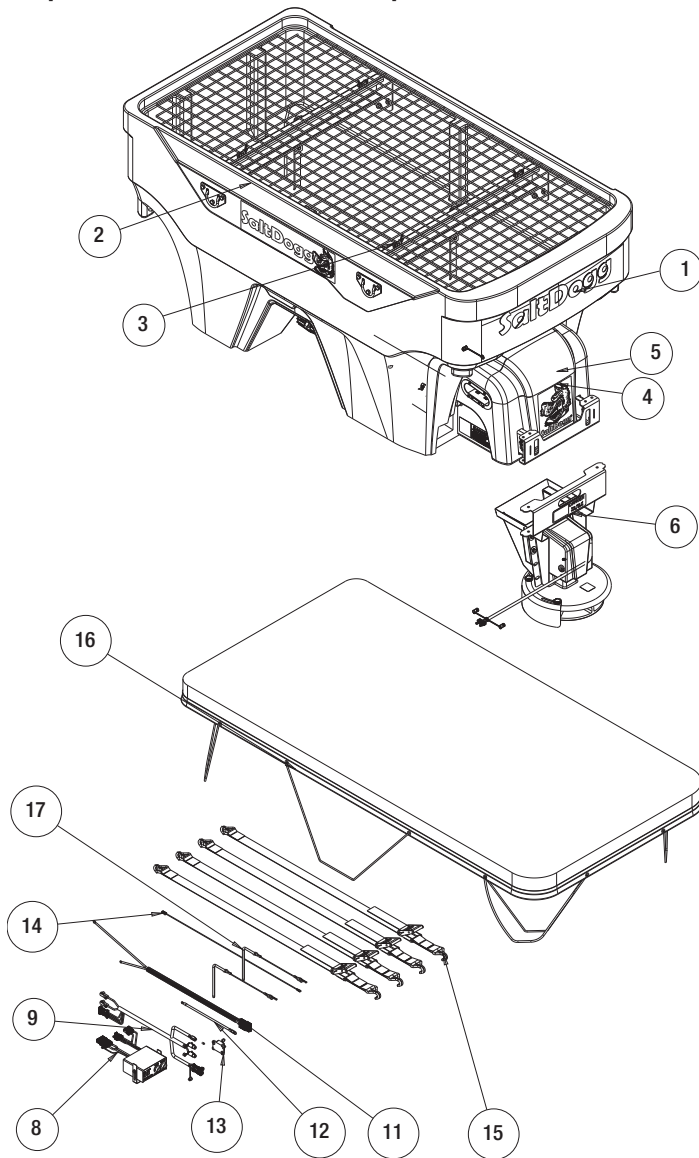

Bill of Materials

ITEM	PART NO.	QTY.	DESCRIPTION
1	3035263	1	HOPPER ASSEMBLY AUGER
2	3034599	1	TOP SCREEN PRO2000
3	66050	4	SNAPPER PIN, 1/4 X 2, YLW ZINC
4	3035380	1	LABEL SERIAL NUMBER PRO2000
5	3035854	1	LABEL PATENT
6	3031475	1	CHUTE SWING ADJ
7	3035376	1	HARDWARE KIT PRO2000
8	3057918	1	CONTROLLER SPEED 12 VDC, 60 AMP
9	3030628	1	WIRE HARNESS MAIN
10	3035938	1	KIT POWER CABLE REPLACES 3016943
11	3035935	1	POWER CORD
12	3001379	1	CABLE, SCH BATTERY 14 IN. (RED)
13	CB150PB	1	BREAKER, 150 AMP.
14	0203700	1	WIRE ASSEMBLY, 36 LONG
15	14965051	1	HOLD DOWN KIT, SPREADER (4 STRAPS)
16	3035377	1	TARP PRO2000
17	3033174	2	PIN, CHUTE ATTACHMENT

Repair Parts - PRO2000CH Spreader

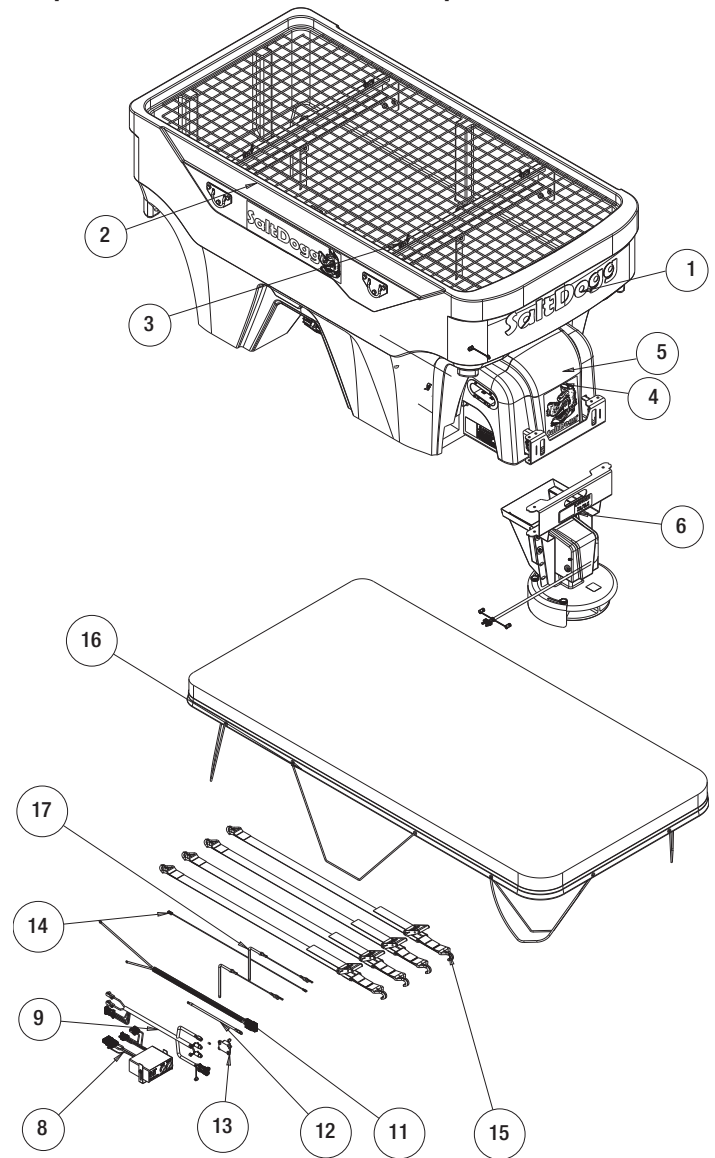

Bill of Materials

ITEM	PART NO.	QTY.	DESCRIPTION
1	3034957	1	HOPPER ASSEMBLY CHAIN
2	3034599	1	TOP SCREEN PRO2000
3	66050	4	SNAPPER PIN, 1/4 X 2, YLW ZINC
4	3035380	1	LABEL SERIAL NUMBER PRO2000
5	3035854	1	LABEL PATENT
6	3031475	1	CHUTE SWING ADJ
7	3035376	1	HARDWARE KIT PRO2000
8	3057918	1	CONTROLLER SPEED 12 VDC, 60 AMP
9	3030628	1	WIRE HARNESS MAIN
10	3035938	1	KIT POWER CABLE REPLACES 3016943
11	3035935	1	POWER CORD
12	3001379	1	CABLE, SCH BATTERY 14 IN. (RED)
13	CB150PB	1	BREAKER, 150 AMP.
14	0203700	1	WIRE ASSEMBLY, 36 LONG
15	14965051	1	HOLD DOWN KIT, SPREADER (4 STRAPS)
16	3035377	1	TARP PRO2000
17	3033174	2	PIN, CHUTE ATTACHMENT

Repair Parts - PRO2500 Auger Hopper Assembly

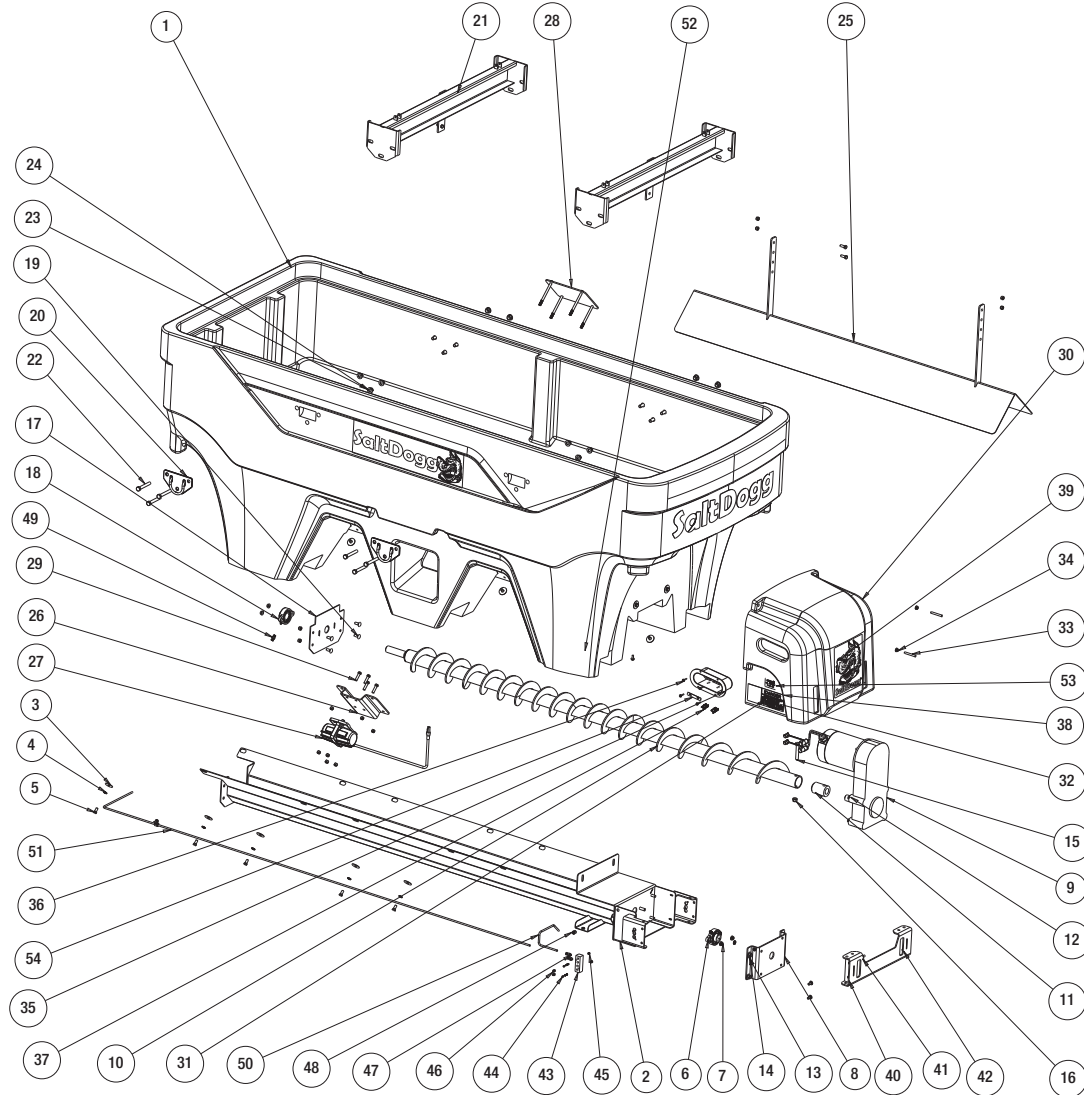

Bill of Materials

ITEM	PART NO.	QTY.	DESCRIPTION
1	3030763	1	HOPPER PRO2500
2	3032999	1	TROUGH WELDMENT PRO2500
3	3007115	12	WASHER, FLAT 3/8 X 1.5 X.048 SST
4	FWL038069009SS	16	WASHER, LOCK RHS-3/8 SST
5	FCS038016075SS	12	SCREW, HHC 3/8-16 X 3/4 SST
6	1410200	1	BEARING, FLANGED 1-1/8"
7	3001255	4	NUT, HEX FLNG 3/8-16 SST
8	3033003	1	SPACER, GEAR MOTOR
9	3024575	1	GEAR MOTOR CONVEYOR 12 VDC
10	3033660	1	AUGER PRO 5.25 VARIABLE LH
11	3033663	1	SLEEVE, AUGER ADAPTER
12	FCS038016100SS	8	SCREW, HHC 3/8-16 X 1 304 SST
13	FWF038100007SS	4	WASHER, FLAT 3/8 USS SST
14	FNE038016044SS	20	NUT, NYLOCK 3/8-16 X 7/16 SST
15	3001250	1	SCREW, HHC-1/2-13 X 3 SST
16	FNE050013053SS	1	NUT, NYLOCK 1/2-13 SS
17	3033070	1	BRACKET BEARING FRONT
18	9240086	1	BEARING, 1-1/4 FLANGE 2 HOLE
19	FCB037516100SS	4	BOLT, 3/8-16 X 1 CARRIAGE SST
20	3022220	4	TIE-DOWN WELDMENT
21	3030854	2	CROSS MEMBER
22	3005140	12	SCREW, HH1/2-13X 3.5, GR 5 ZN
23	FWF050106010	12	WASHER, FLAT 1/2" SAE ZINC
24	FNE050013053	12	NUT, NYLOCK 1/2-13 ZINC
25	3030863	1	INVERTED VEE, PRO2500
26	3039179	1	BRACKET VIBRATOR
27	3007416	1	VIBRATOR 200 LBS 12 VDC
28	3031176	1	PLATE WELDMENT, VIBRATOR
29	FCS038016150SS	4	SCREW, HX HD CAP 3/8-16 X 1-1/2 SST

ITEM	PART NO.	QTY.	DESCRIPTION
30	3031169	1	SHROUD
31	FWF025063007SS	2	WASHER, FLAT 1/4 SAE SS
32	FCS025020075SS	2	SCREW, CAP 1/4-20 X 3/4 SST
33	3033165	2	STUD THREADED 5/16-18 X 2.5 SST
34	3006719	2	NUT, HEX FLANGE - 5/16-18 SS
35	3031203	1	MOUNT CONNECTORS
36	3007522	7	SCREW, SHEET MTL #12x1.0 HEX WASHER HD SS'f
37	3031276	2	CLIP ATTACHMENT, CONNECTOR DEUTSCH
38	3032591	1	DECAL, DANGER, MOVING CONVEYOR/AUGER
39	3032595	1	DECAL, CAUTION, MOUNTING
40	3033076	1	CHUTE ATTACHMENT
41	3012144	4	BOLT, CARRIAGE, 5/16-18 X 1 SST
42	FNE031018034SS	4	NUT, NYLOCK 5/16-18 SS
43	3035346	1	RIGHT ANGLE JUNCTION BLOCK
44	3035357	2	SCREW SOCKET HD, RND 8-32X 1.50 SST
45	3035358	2	NUT, NYLOCK 8-32 SST, BLACK OXIDE
46	800	2	GREASE FITTING, 1/4 STD
47	3035347	2	GREASE FITTING 1 MTU BE 1/8 NPT STRAIGHT
48	3035742	2	BUSHING SNAP THICK PANEL
49	3035344	2	GREASE FITTING 1 MTU BE 1/4-28 MALE STRAIGHT
50	3035359	1	GREASE TUBE REAR BEARING AUGER
51	3036016	1	GREASE TUBE FRONT BEARING AUGER
52	4375	3	CLAMP, HOSE .4375, 9/32 HOLE
53	3035854	1	LABEL PATENT
54	3033172	1	DECAL CONNECTION

Repair Parts - PRO2500CH Chain Hopper Assembly

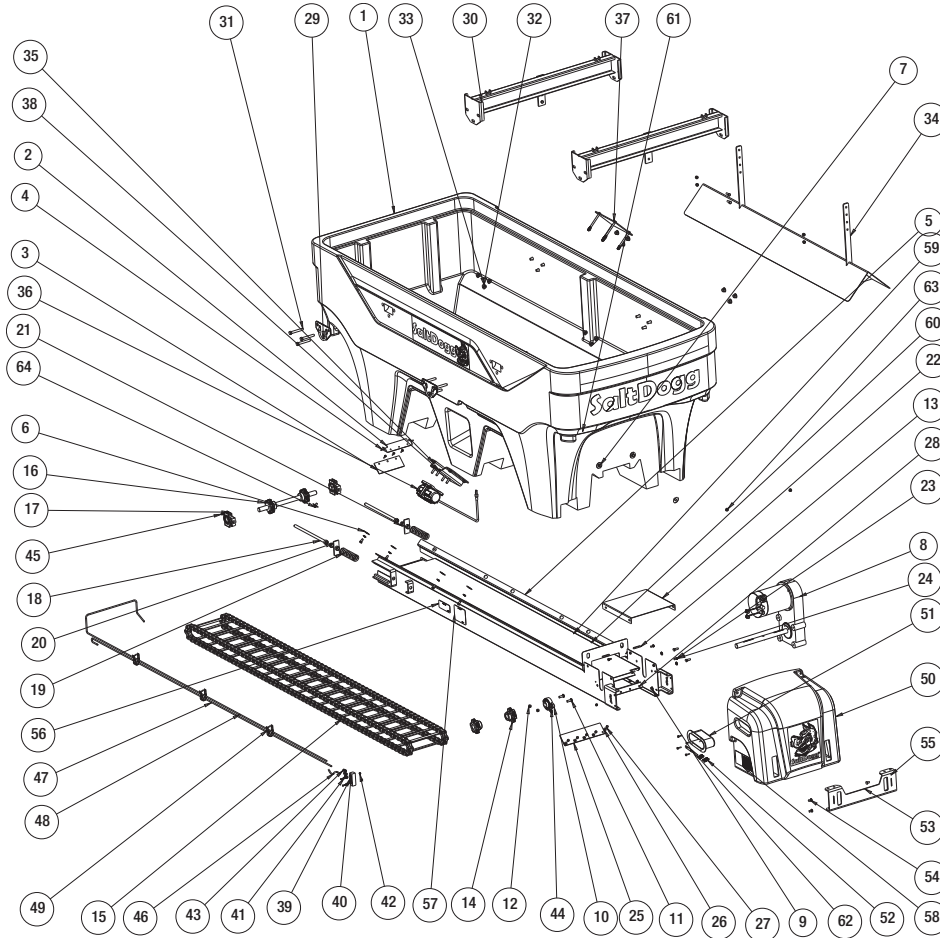

Bill of Materials

ITEM	PART NO.	QTY.	DESCRIPTION
1	3030763	1	HOPPER PRO2500
2	3033164	1	WIPER BRACKET
3	3035269	1	WIPER BELT, FRONT
4	3007522	12	SCREW, SHEET MTL #12x1.0 HEX WASHER HD SS'
5	3027772	1	TROUGH CHAIN PRO500
6	3007115	12	WASHER, FLAT 3/8 X 1.5 X.048 SST
7	FWL038069009SS	16	WASHER, LOCK RHS-3/8 SST
8	3013821	1	GEAR MOTOR CONVEYOR 12 VDC
9	FCS038016100SS	8	SCREW, HHC 3/8-16 X 1 304 SST
10	1410200	1	BEARING, FLANGED 1-1/8"
11	3031483	2	BOLT, 3/8-16 X 1 CARRIAGE SHORT NECK SST
12	FNE038016044SS	14	NUT, NYLOCK 3/8-16 X 7/16 SST
13	KS402	2	KEY, 1/4 X 1/4X2
14	1410250	2	SPROCKET, 6 TOOTH PINTLE CHAIN
15	1401100P	1	CHAIN ASSY D662 122 LINKS
16	3008571	1	SHAFT IDLER, ASSEMBLY
17	1411001	2	BEARING, IDLER TAKE UP
18	3023046	2	BOLT, WELDED TAKE UP
19	3023022	2	SPRING CHAIN TENSION
20	3031199	2	TAKE-UP NUT WELDMENT
21	FNH063011054SS	2	NUT, HH 5/8-11 X 17/32 HIGH SST
22	3031195	1	CHAIN COVER
23	FWL025050006SS	4	WASHER, 1/4 IN. SPRING LOCK SST
24	FCS025020075SS	6	SCREW, CAP 1/4-20 X 3/4 SST
25	1410241	1	WIPER BELT, HOPPER
26	FWF025063007SS	7	WASHER, FLAT 1/4 SAE SS
27	3008549	5	SCREW, HEXHD CAP 1/4-20X.5 SST
28	FNE025020031SS	5	NUT, NYLON INSERT 1/4-20 SST
29	3022220	4	TIE-DOWN WELDMENT
30	3030854	2	CROSS MEMBER
31	3005140	12	SCREW, HH1/2-13 x 3.5, GR 5 ZN
32	FWF050106010	12	WASHER, FLAT 1/2" SAE ZINC
33	FNE050013053	12	NUT, NYLOCK 1/2-13 ZINC

ITEM	PART NO.	QTY.	DESCRIPTION
34	3030863	1	INVERTED VEE, PRO2500
35	3039179	1	BRACKET VIBRATOR
36	3007416	1	VIBRATOR 200 LBS 12 VDC
37	3031176	1	PLATE WELDMENT, VIBRATOR
38	FCS038016150SS	4	SCREW, HX HD CAP 3/8-16 X 1-1/2 SST
39	3035346	1	RIGHT ANGLE JUNCTION BLOCK
40	800	3	GREASE FITTING, 1/4 STD
41	3035357	2	SCREW SOCKET HD, RND 8-32X 1.50 SST
42	3035358	2	NUT, NYLOCK 8-32 SST, BLACK OXIDE
43	3035347	3	GREASE FITTING 1 MTU BE 1/8 NPT STRAIGHT
44	3035344	1	GREASE FITTING 1 MTU BE 1/4-28 MALE STRAIGHT
45	3035345	2	GREASE FITTING 1 MTU BE 1/4-28 MALE 90 DEGREE
46	3035348	1	GREASE HOSE REAR BEARING
47	3036051	1	GREASE HOSE FRONT DR SIDE
48	3036052	1	GREASE HOSE FRONT PS SIDE
49	5000	3	HOSE CLAMP, .375 DIA
50	3031169	1	SHROUD
51	3031203	1	MOUNT CONNECTORS
52	3031276	2	CLIP ATTACHMENT, CONNECTOR DEUTSCH
53	3033076	1	CHUTE ATTACHMENT
54	3012144	4	BOLT, CARRIAGE, 5/16-18 X 1 SST
55	FNE031018034SS	4	NUT, NYLOCK 5/16-18 SS
56	1499035	2	LABEL, WARNING 3
57	1499030	1	LABEL, CAUTION 1 (PAYLOAD)
58	3032591	1	DECAL, DANGER, MOVING CONVEYOR/AUGER
59	3032593	1	DECAL, DANGER, CONVEYOR
60	3032595	1	DECAL, CAUTION, MOUNTING
61	3033165	2	STUD THREADED 5/16-18 X 2.5 SST
62	3033172	1	DECAL CONNECTION
63	3006719	2	NUT, HEX FLANGE - 5/16-18 SS
64	FCS038016075SS	12	SCREW, HHC-3/8-16 X 3/4 SST

Repair Parts - PRO2500 Spreader

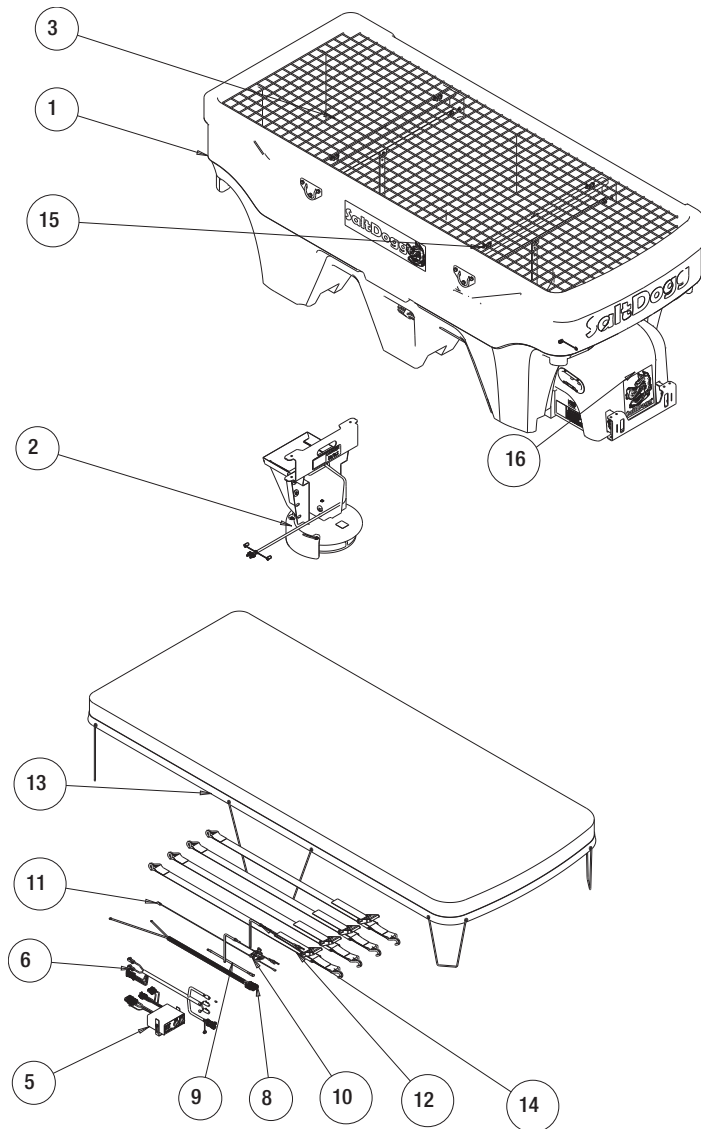

Bill of Materials

ITEM	PART NO.	QTY.	DESCRIPTION
1	3033301	1	HOPPER ASSEMBLY PRO2500
2	3031475	1	CHUTE SWING ADJ
3	3030853	1	TOP SCREEN PRO2500
4	3031797	1	HARDWARE KIT PRO2500
5	3057918	1	CONTROLLER SPEED 12 VDC, 60 AMP
6	3030628	1	WIRE HARNESS MAIN
7	3035938	1	KIT POWER CABLE REPLACES 3016943
8	3035935	1	POWER CORD
9	3001379	1	CABLE, SCH BATTERY 14 IN. (RED)
10	CB150PB	1	BREAKER, 150 AMP.
11	0203700	1	WIRE ASSEMBLY, 36 LONG
12	14965051	1	HOLD DOWN KIT, SPREADER (4 STRAPS)
13	3030857	1	TARP PRO2500
14	3033174	2	PIN, CHUTE ATTACHMENT
15	66050	4	SNAPPER PIN, 1/4 X 2, YLW ZINC
16	3036015	1	LABEL SERIAL NUMBER PRO2500

Repair Parts - PRO2500CH Spreader

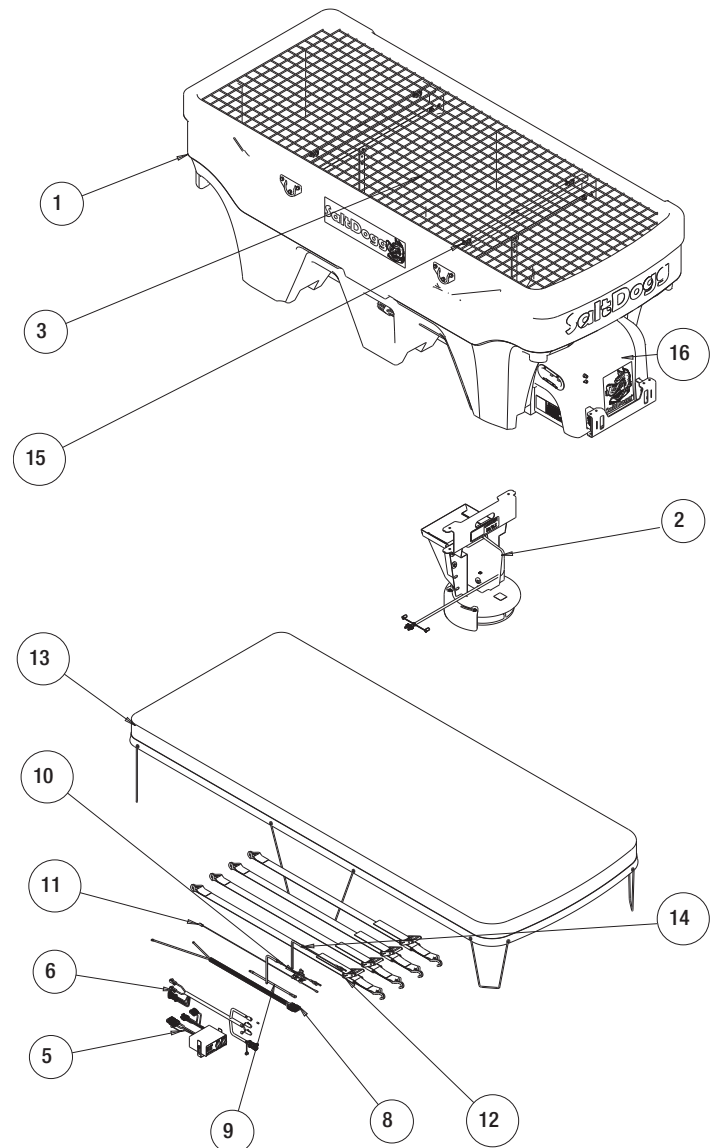

Bill of Materials

ITEM	PART NO.	QTY.	DESCRIPTION
1	3030766	1	HOPPER ASSEMBLY PRO2500
2	3031475	1	CHUTE SWING ADJ
3	3030853	1	TOP SCREEN PRO2500
4	3031797	1	HARDWARE KIT PRO2500
5	3057918	1	CONTROLLER SPEED 12 VDC, 60 AMP
6	3030628	1	WIRE HARNESS MAIN
7	3035938	1	KIT POWER CABLE REPLACES 3016943
8	3035935	1	POWER CORD
9	3001379	1	CABLE, SCH BATTERY 14 IN. (RED)
10	CB150PB	1	BREAKER, 150 AMP.
11	0203700	1	WIRE ASSEMBLY, 36 LONG
12	14965051	1	HOLD DOWN KIT, SPREADER (4 STRAPS) BLA
13	3030857	1	TARP PRO2500
14	3033174	2	PIN, CHUTE ATTACHMENT
15	66050	4	SNAPPER PIN, 1/4X2, YLWZINC
16	3036015	1	LABEL SERIAL NUMBER PRO2500

Repair Parts - PRO3000 Auger Hopper Assembly

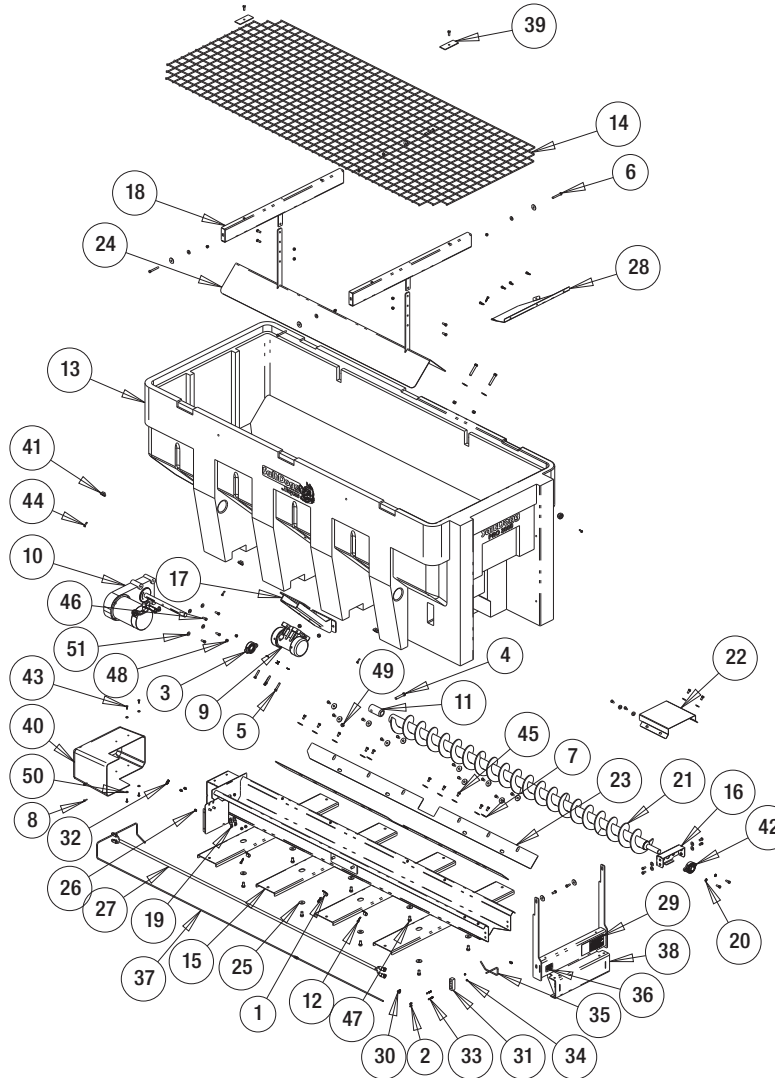

Bill of Materials

ITEM	PART NO.	QTY.	DESCRIPTION
1	750	3	CLAMP, HOSE .750, 13/32 HOLE
2	800	2	GREASE FITTING, 1/4 STD
3	1410200	1	BEARING, FLANGED 1-1/8"
4	3001250	3	SCREW, HHC-1/2-13 X 3 SST
5	3007066	4	SCREW, HHC-3/8-16 X 2 SST
6	3007068	4	CAP SCREW, HX HD-3/8-16X3 SST
7	3007115	28	WASHER, FLAT 3/8 X 1.5 X.048 SST
8	3007522	2	SCREW, SHEET MTL #12X1.0 HEX WASHER HD SST
9	3012081	1	VIBRATOR 450 LBS, 12 VDC
10	3013821	1	GEAR MOTOR CONVEYOR 12 VDC
11	3014858	1	SLEEVE, AUGER ADAPTER
12	3015925	8	SCREW #14X1.25 SST
13	3015951	1	HOPPER POLY 3.0 CU YA
14	3015999	1	TOP SCREEN SHPE3000
15	3016165	1	TROUGH AUGER, WELDMENT
16	3016192	1	BEARING BRACKET ASSEMBLY
17	3016696	1	BRACKET, VIBRATOR WELDMENT
18	3016701	2	BRACKET WELDMENT, INVERTED VEE
19	3017121	2	BRACKET, RECEPTACLE SZ8 DEUTSCH
20	3017356	6	WASHER, EXTERNAL TOOTH LOCK 3/8 SS
21	3017358	1	AUGER SHPE3000
22	3017370	1	COVER, TROUGH SHPE3000
23	3017371	2	SHIELD TROUGH, SHPE3000
24	3017393	1	INVERTED VEE, SHPE300
25	3017858	10	WASHER FLAT .5 ID 1.5 OD SST
26	3017982	3	WIRE BUSHING OPEN/CLOSED HEYCO 2867

ITEM	PART NO.	QTY.	DESCRIPTION
27	3019878	1	EXTENSION WIRE HARNESS 8FT MOTOR
28	3025124	1	COVER DISCHARGE SHPE3000
29	3032591	1	DECAL, DANGER, MOVING CONVEYOR/AUGER
30	3035345	2	GREASE FITTING 1/4TUBE 1/4-28 MALE 90 DEGREES
31	3035346	1	RIGHT ANGLE JUNCTION BLOCK
32	3035347	2	GREASE FITTING 1/4TUBE 1/8 NPT STRAIGHT
33	3035357	2	SCREW SOCKET HD, RND 8-32X 1.50 SST
34	3035358	2	NUT, NYLOCK 8-32 SST, BLACK OXIDE
35	3035359	1	GREASE TUBE REAR BEARING AUGER
36	3035854	1	LABEL PATENT
37	3036052	1	GREASE HOSE FRONT PS SIDE
38	3045623	1	CHUTE ATTACHMENT
39	3045720	2	RETAINER
40	3045734	1	HOUSING, MOTOR
41	3047855	6	ANCHOR, TARP
42	9240086	1	BEARING, 1-1/4 FLANGE 2 HOLE
43	FCS025020075SS	4	SCREW, CAP 1/4-20 X 3/4 SST
44	FCS025020100SS	6	SCREW, CAP HEX HD 1/4-20 X 1 SST
45	FCS038016075SS	28	SCREW, HHC-3/8-16 X 3/4 SST
46	FCS038016100SS	16	SCREW, HHC 3/8-16 X 1 304 SST
47	FCS050013100SS	8	SCREW, HHC-1/2-13 X 1 SST
48	FNE038016044SS	12	NUT, NYLOCK 3/8-16 X 7/16 SST
49	FNE050013053SS	5	NUT, NYLOCK 1/2-13 SS
50	FWF025063007SS	4	WASHER, FLAT 1/4 SAE SS
51	FWF038100007SS	16	WASHER, FLAT 3/8 USS SST

Repair Parts - PRO3000CH Chain Hopper Assembly

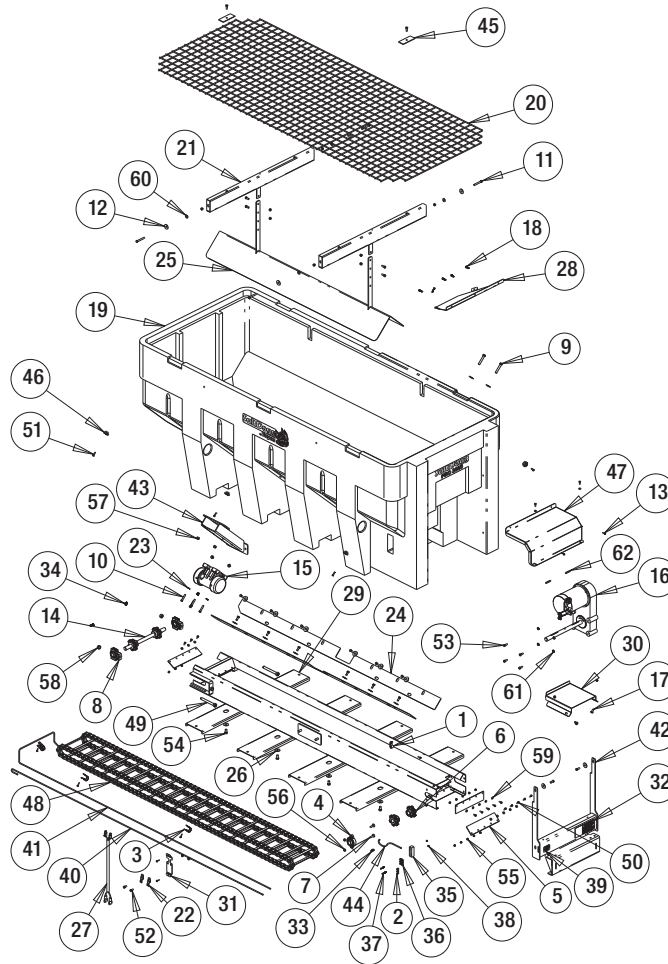

Bill of Materials

ITEM	PART NO.	QTY.	DESCRIPTION
1	750	1	CLAMP, HOSE .750, 13/32 HOLE
2	800	3	GREASE FITTING, 1/4 STD
3	5000	3	HOSE CLAMP, .375 DIA
4	1410200	1	BEARING, FLANGED 1-1/8"
5	1410241	3	WIPER BELT, HOPPER
6	1410250	2	SPROCKET, 6 TOOTH PINTLE CHAIN
7	1410305	2	BOLT, 3/8 X 1 1/4, LOW HEAD
8	1411001	2	BEARING, IDLER TAKE UP
9	3001250	2	SCREW, HHC-1/2-13 X 3 SST
10	3007066	4	SCREW, HHC-3/8-16 X 2 SST
11	3007068	4	CAP SCREW, HX HD-3/8-16X3 SST
12	3007115	8	WASHER, FLAT 3/8 X 1.5 X.048 SST
13	3007522	8	SCREW, SHEET MTL #12X1.0 HEX WASHER HD SST
14	3008571	1	SHAFT IDLER, ASSEMBLY
15	3012081	1	VIBRATOR 450 LBS, 12 VDC
16	3013821	1	GEAR MOTOR CONVEYOR 12 VDC
17	3014960	2	BOLT, 3/8-16 X 1 CARRIAGE SHORT NECK SST
18	3015925	5	SCREW #14X1.25 SST
19	3015951	1	HOPPER POLY 3.0 CU YA
20	3015999	1	TOP SCREEN SHPE3000
21	3016701	2	BRACKET WELDMENT, INVERTED VEE
22	3017121	2	BRACKET, RECEPTACLE SZ8 DEUTSCH
23	3017356	4	WASHER, EXTERNAL TOOTH LOCK 3/8 SS
24	3017371	2	SHIELD TROUGH, SHPE3000
25	3017393	1	INVERTED VEE, SHPE300
26	3017858	22	WASHER FLAT .5 ID 1.5 OD SST
27	3024521	1	HARNES,UTS,LID LONG
28	3025124	1	COVER DISCHARGE SHPE3000
29	3027301	1	TROUGH WELDMENT, CHAIN
30	3027701	1	COVER, TROUGH SHPE3000
31	3027766	1	BRACKET, CONNECTORS
32	3032591	1	DECAL, DANGER, MOVING CONVEYOR/AUGER

ITEM	PART NO.	QTY.	DESCRIPTION
33	3035344	1	GREASE FITTING 1/4TUBE 1/4-28 MALE STRAIGHT
34	3035345	2	GREASE FITTING 1/4TUBE 1/4-28 MALE 90 DEGREES
35	3035346	1	RIGHT ANGLE JUNCTION BLOCK
36	3035347	3	GREASE FITTING 1/4TUBE 1/8 NPT STRAIGHT
37	3035357	2	SCREW SOCKET HD, RND 8-32X 1.50 SST
38	3035358	2	NUT, NYLOCK 8-32 SST, BLACK OXIDE
39	3035854	1	LABEL PATENT
40	3036051	1	GREASE HOSE FRONT DR SIDE
41	3036052	1	GREASE HOSE FRONT PS SIDE
42	3045623	1	CHUTE ATTACHMENT
43	3045650	1	BRACKET, VIBRATOR WELDMENT
44	3045674	1	GREASE TUBE REAR BEARING
45	3045720	2	RETAINER
46	3047855	6	ANCHOR, TARP
47	3047891	1	COVER, REAR MOTOR, PRO3000CH
48	14011 00P	1	CHAIN ASSY D662 122 LINKS
49	141050WSS	2	BOLT, WELDED TAKE UP, SCH IDLER
50	FCS025020075SS	15	SCREW, CAP 1/4-20 X 3/4 SST
51	FCS025020100SS	6	SCREW, CAP HEX HD 1/4-20 X 1 SST
52	FCS038016075SS	2	SCREW, HHC-3/8-16 X 3/4 SST
53	FCS038016100SS	26	SCREW, HHC 3/8-16 X 1 304 SST
54	FCS050013100SS	8	SCREW, HHC-1/2-13 X 1 SST
55	FNE025020031SS	13	NUT, NYLON INSERT 1/4-20 SST
56	FNE038016044SS	14	NUT, NYLOCK 3/8-16X7/16 SST
57	FNE050013053SS	4	NUT, NYLOCK 1/2-13 SS
58	FNH063011054SS	2	NUT, HH 5/8-11 X 17/32 HIGH SST
59	FWF025063007SS	15	WASHER, FLAT 1/4 SAE SS
60	FWF038100007SS	4	WASHER, FLAT 3/8 USS SST
61	FWL038069009SS	4	WASHER, LOCK RHS-3/8 SST
62	KS402	2	KEY, 1/4 X 1/4X2

Repair Parts - PRO3000 Spreader

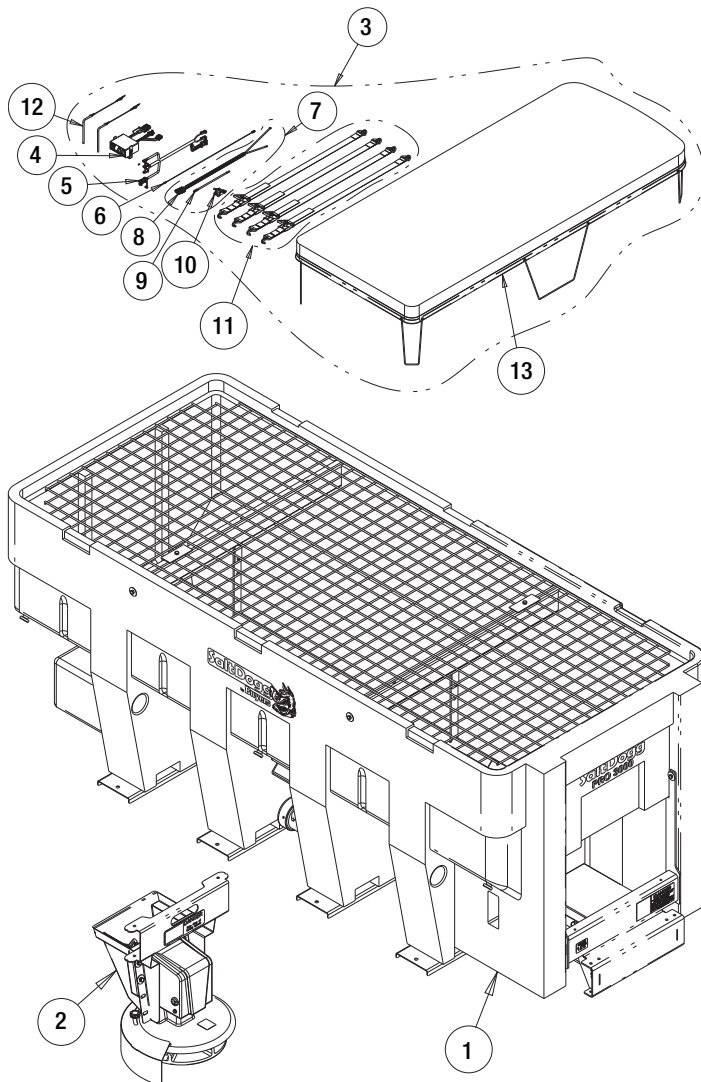

Bill of Materials

ITEM	PART NO.	QTY.	DESCRIPTION
1	3045622	1	HOPPER AUGER ASSEMBLY PRO3000
2	3031475	1	CHUTE SWING ADJ
3	3045998	1	HARDWARE KIT PRO3000/3000CH
4	3057918	1	CONTROLLER SPEED 12 VDC, 60 AMP
5	3030628	1	WIRE HARNESS MAIN
6	0203700	1	WIRE ASSEMBLY, 36 LONG
7	3035938	1	KIT POWER CABLE REPLACES 3016943
8	3035935	1	POWER CORD
9	3001379	1	CABLE, SCH BATTERY 14 IN. (RED)
10	CB150PB	1	BREAKER, 150 AMP.
11	1496505	1	HOLD DOWN KIT, SPREADER (4 STRAPS)
12	3033174	2	PIN, CHUTE ATTACHMENT
13	3030857	1	TARP PRO2500 & PRO3000

Repair Parts - PRO3000CH Spreader

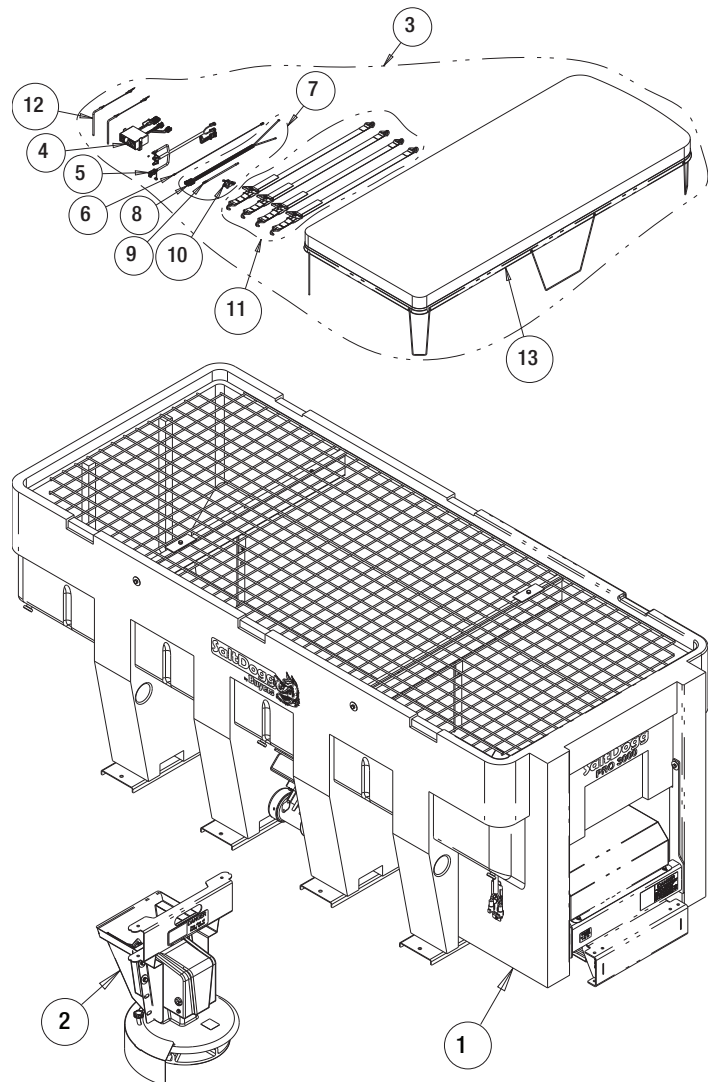

Bill of Materials

ITEM	PART NO.	QTY.	DESCRIPTION
1	3045634	1	HOPPER, CHAIN ASSEMBLY PRO3000CH
2	3031475	1	CHUTE SWING ADJ
3	3045998	1	HARDWARE KIT PRO3000/3000CH
4	3057918	1	CONTROLLER SPEED 12 VDC, 60 AMP
5	3030628	1	WIRE HARNESS MAIN
6	0203700	1	WIRE ASSEMBLY, 36 LONG
7	3035938	1	KIT POWER CABLE REPLACES 3016943
8	3035935	1	POWER CORD
9	3001379	1	CABLE, SCH BATTERY 14 IN. (RED)
10	CB150PB	1	BREAKER, 150 AMP.
11	1496505	1	HOLD DOWN KIT, SPREADER (4 STRAPS)
12	3033174	2	PIN, CHUTE ATTACHMENT
13	3030857	1	TARP PRO2500 & PRO3000

PRO4000 Hopper Assembly

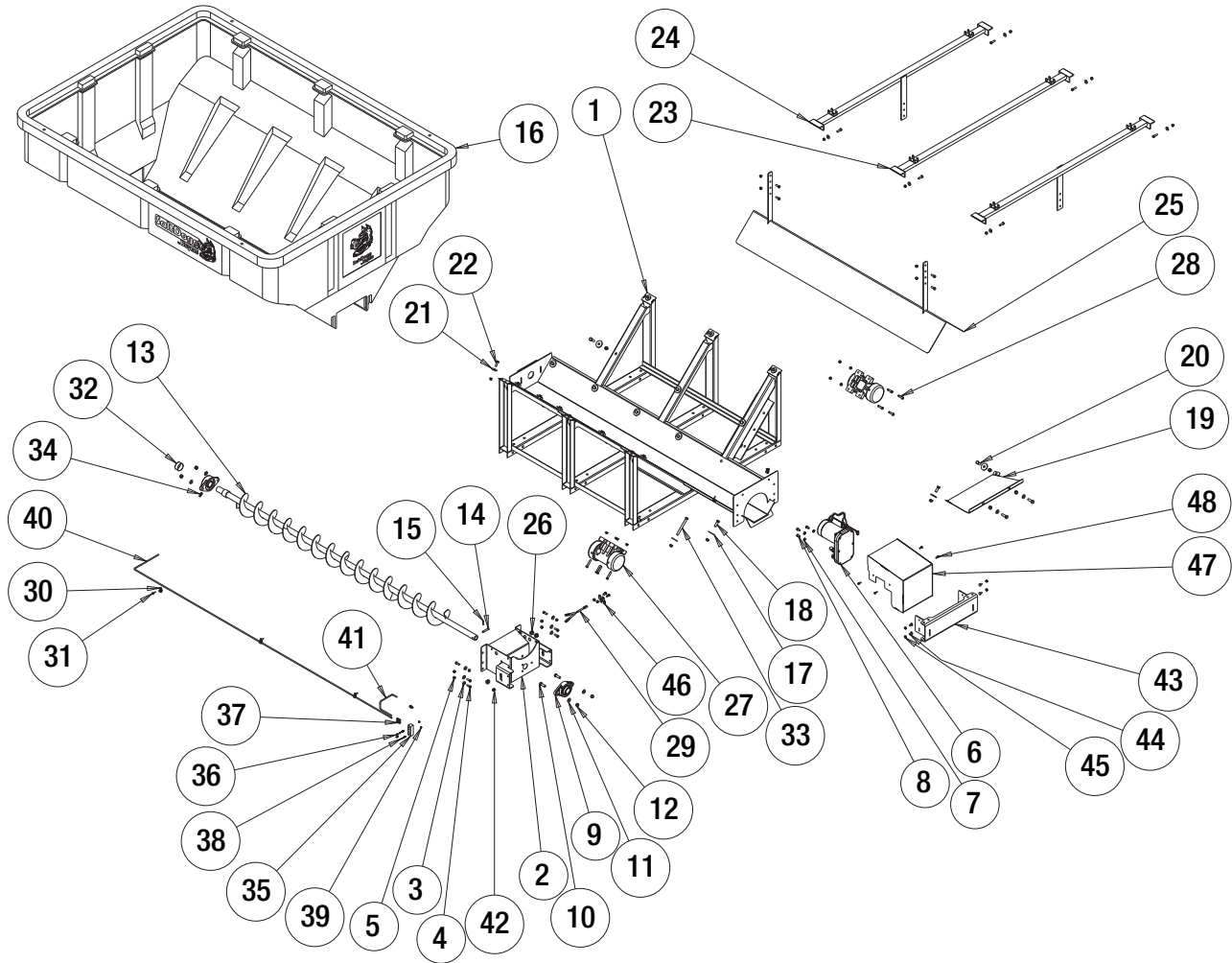

Bill of Materials

ITEM	PART NO.	QTY.	DESCRIPTION
1	3052795	1	TROUGH WELDMENT, PRO4000
2	3053262	1	BRACKET, WELDMENT GEAR MOTOR
3	FWF038100007SS	12	WASHER, FLAT 3/8 USS SST
4	FCS038016100SS	10	SCREW, HHC 3/8-16 X 1 304 SST
5	FNE038016044SS	32	NUT, NYLOCK 3/8-16 X 7/16 SST
6	3038812	1	GEAR MOTOR, AUGER SHPE4000
7	FWL038069009SS	3	WASHER, LOCK RHS-3/8 SST
8	FCS038016075SS	5	SCREW, HHC-3/8-16 X 3/4 SST
9	2F24SCR	2	BEARING FLANGE 2 HOLES .75 ID SET SCREW
10	FCS050013150SS	4	SCREW, HHC-1/2-13 X 1.50 SST
11	3003873	14	WASHER, FLAT 1/2" SAE TYPE A SST
12	FNE050013053SS	24	NUT, NYLOCK 1/2-13 SS
13	3012001	1	AUGER SHPE4000
14	1410803	1	PIN, CLEVIS, 3/8 X 2, 1038 ST, YZN
15	FPC013000100	1	COTTER PIN, 1/8 X 1, ZINC
16	3011999	1	HOPPER POLY 4 CU YA
17	3013516	18	WASHER, FLAT 1/2 ID 2.0 OD .135 THK SST
18	3006723	14	SCREW, HEX HD 1/2-13x1.5 GR5 SS
19	3012607	1	COVER DISCHARGE
20	FCS050013125SS	2	SCREW, HHC-1/2-13 X 1-1/4 SST
21	3014189	6	WASHER, FLAT 3/8 X 1.5 X.120 SST
22	FCS038016125SS	12	SCREW, HHC-3/8-16 X 1.25 SST
23	3013279	1	SCREEN SUPPORT, SHPE4000
24	3039490	2	SCREEN SUPPORT, SHPE4000

ITEM	PART NO.	QTY.	DESCRIPTION
25	3039492	1	INVERTED VEE, WELDMENT
26	3007821	3	STRAIN RELIEF BUSHING
27	3012081	2	VIBRATOR 450 LBS, 12 VDC
28	3007066	8	SCREW, HHC-3/8-16 X 2 SST
29	3015652	1	ADAPTER DUAL VIBRATORS, SHPE4000
30	4375	5	CLAMP, HOSE .4375, 9/32 HOLE
31	3007522	5	SCREW, SHEET MTL #12x1.0 HEX WASHER HD SST
32	3013541	1	CAP VYNIL 2.0 ID 1.0 LG
33	3019616	2	SCREW, HEX HEAD CAP 1/2-13 X 5.00 SST
34	3035344	2	GREASE FITTING 1/4TUBE 1/4-28 MALE STRAIGHT
35	3035346	1	RIGHT ANGLE JUNCTION BLOCK
36	800	2	GREASE FITTING, 1/8in NPT, STRAIGHT
37	3035347	2	GREASE FITTING 1/4TUBE 1/8 NPT STRAIGHT
38	3035357	2	SCREW SOCKET HD, RND 8-32X 1.50 SST
39	3035358	2	NUT, NYLOCK 8-32 SST, BLACK OXIDE
40	3036016	1	GREASE TUBE FRONT BEARING AUGER
41	3035359	1	GREASE TUBE REAR BEARING AUGER
42	3035742	1	BUSHING SNAP THICK PANEL
43	3053487	1	CHUTE ATTACHMENT, 4000/6000
44	3012144	4	BOLT, CARRIAGE, 5/16-18 X 3/4 RD HD SST
45	FNE031018034SS	4	NUT, NYLOCK, 5/16-18, GR A, SST
46	3017121	2	BRACKET, RECEPTACLE SZ8 DEUTSCH
47	3053680	1	MOTOR COVER, PRO4000
48	FCS025020075SS	4	SCREW, CAP 1/4-20 X 3/4 SST

PRO4000CH Hopper Assembly

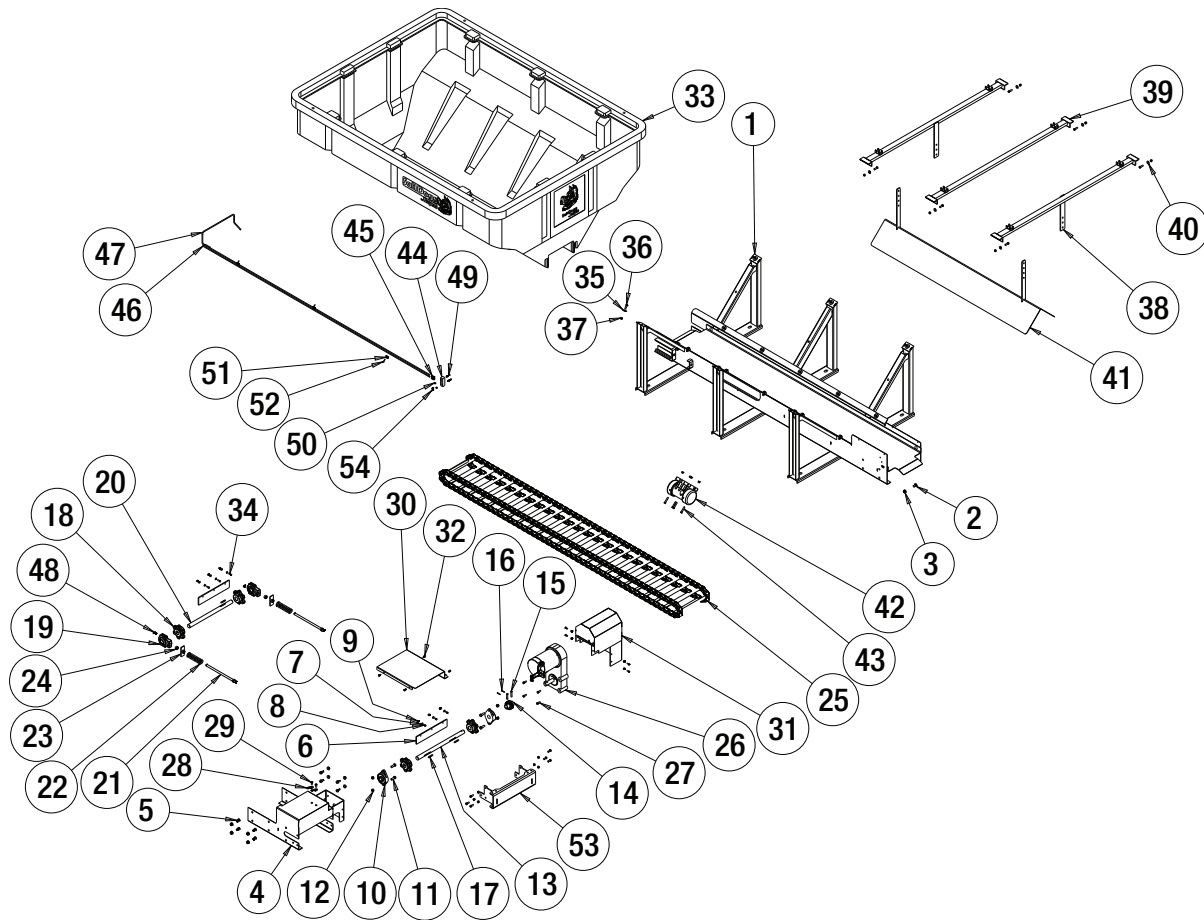

Bill of Materials

ITEM	PART NO.	QTY.	DESCRIPTION
1	3038843	1	TROUGH WELDMENT SHPE4000CH
2	3001522	4	BOLT, CARRIAGE 1/2-13 X 1 SST
3	3001523	12	NUT, HX FLNG-1/2-13 SST
4	3052649	1	MOTOR DECK, WELDMENT
5	3004278	8	SCREW, BTN HD SOC CAP 1/2-13x 1 SST
6	3008872	2	WIPER BELT, HOPPER
7	FWF025063007SS	9	WASHER, FLAT 1/4 SAE SS
8	FCS025020075SS	7	SCREW, CAP 1/4-20 X 3/4 SST
9	FNE025020031SS	10	NUT, NYLOCK, 1/4-20, GR A, SST
10	3008294	2	BEARING, FLANGED
11	3006723	4	SCREW, HEX HD 1/2-13x1.5 GR5 SS
12	FNE050013053SS	4	NUT, NYLOCK 1/2-13 SS
13	3008316	1	SHAFT, SPROCKET DRIVE END
14	3008289	1	COUPLING, DRIVE SHAFT/ GEARBOX
15	1410803	2	PIN, CLEVIS, 3/8 X 2, 1038 ST, YZN
16	FPC013000100	2	COTTER PIN, 1/8 X 1, ZINC
17	KS402	3	KEY, 1/4 X 1/4 X 2
18	3008300	4	SPROCKET, D667H CHAIN
19	3008290	2	BEARING, HEAVY DUTY TAKE-UP
20	3008317	1	SHAFT, IDLER SPROCKET
21	3023046	2	BOLT, WELDED TAKE UP
22	3023022	2	SPRING CHAIN TENSION
23	3031199	2	TAKE-UP NUT WELDMENT
24	FNH063011054SS	2	NUT, HH 5/8-11 X 17/32 HIGH SST
25	3008860	1	CHAIN, 9FT. D667H CONVEYOR
26	3024575	1	GEAR MOTOR CONVEYOR 12 VDC
27	FCS038016100SS	10	SCREW, HHC 3/8-16 X 1 304 SST

ITEM	PART NO.	QTY.	DESCRIPTION
28	3017121	2	BRACKET, RECEPTACLE SZ8 DEUTSCH
29	FCS038016075SS	2	SCREW, HHC-3/8-16 X 3/4 SST
30	3039489	1	COVER, CHAIN
31	3036883	1	WELDMENT, MOTOR COVER
32	3015873	4	SCREW #12-14x.74 SS SELF DRIL HEX WASHER HD
33	3038847	1	HOPPER POLY 4 CU YA
34	FCS025020100SS	3	SCREW, CAP HEX HD 1/4-20 X 1 SST
35	3007115	16	WASHER, FLAT 3/8 X 1.5 X .048 SST
36	FCS038016125SS	22	SCREW, HHC-3/8-16 X 1.25 SST
37	FNE038016044SS	32	NUT, NYLOCK 3/8-16 X 7/16 SST
38	3039490	2	SCREEN SUPPORT, SHPE4000
39	3013279	1	SCREEN SUPPORT, SHPE4000
40	FWF038100007SS	6	WASHER, FLAT 3/8 USS SST
41	3039492	1	INVERTED VEE, WELDMENT
42	3012081	1	VIBRATOR 450 LBS, 12 VDC
43	3007066	4	SCREW, HHC-3/8-16 X 2 SST
44	3035346	1	RIGHT ANGLE JUNCTION BLOCK
45	3035347	2	GREASE FITTING 1/4TUBE 1/8 NPT STRAIGHT
46	3036051	1	GREASE HOSE FRONT DR SIDE
47	3036052	1	GREASE HOSE FRONT PS SIDE
48	3035345	2	GREASE FITTING 1/4TUBE 1/4-28 MALE 90 DEGREES
49	3035357	2	SCREW SOCKET HD, RND 8-32X 1.50 SST
50	3035358	2	NUT, NYLOCK 8-32 SST, BLACK OXIDE
51	4375	3	CLAMP, HOSE .4375, 9/32 HOLE
52	3007522	3	SCREW, SHEET MTL #12x1.0 HEX WASHER HD SST
53	3052651	1	CHUTE ATTACHMENT, PRO4000/6000
54	800	2	GREASE FITTING, 1/8in NPT, STRAIGHT

PRO4000 Assembly

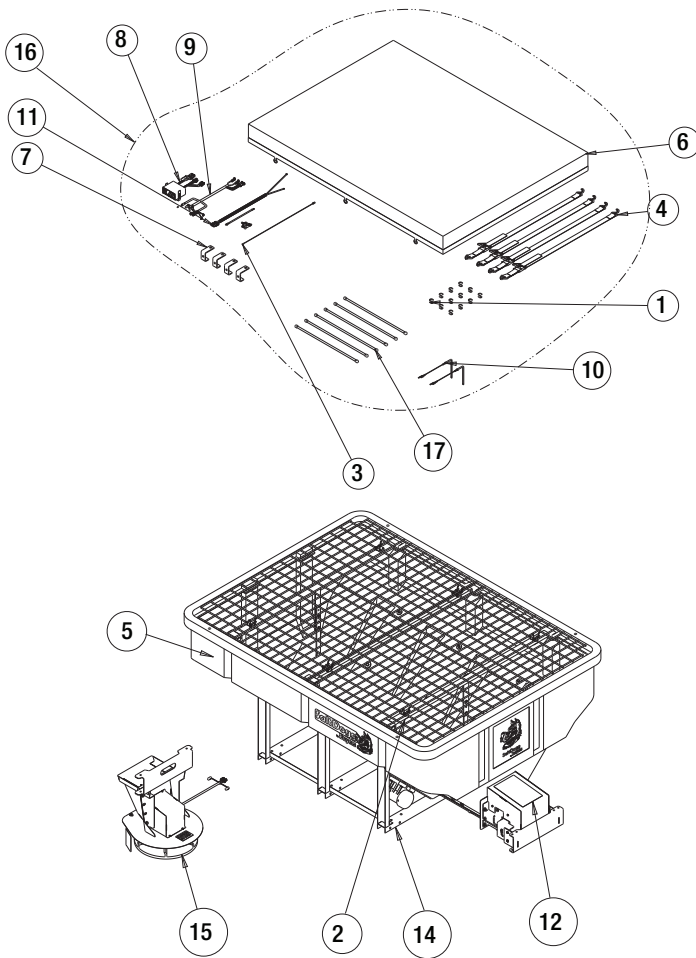

Bill of Materials

ITEM	PART NO.	QTY.	DESCRIPTION
1	9225	12	S-HOOK, 2.5" ZN, TARP STRAP
2	66050	8	SNAPPER PIN, 1/4 X 2, YLW ZINC
3	0203700	1	WIRE ASSEMBLY, 36 LONG
4	1496505	1	HOLD DOWN KIT, SPREADER (4 STRAPS)
5	3012458	2	WIRE MESH, TOP SCREEN
6	3012959	1	TARP, SHPE4000
7	3013589	4	HOOK, TIE-DOWN SHPE4000
8	3057918	1	CONTROLLER SPEED 12 VDC, 60 AMP
9	3030628	1	WIRE HARNESS MAIN
10	3033174	2	PIN, CHUTE ATTACHMENT
11	3035938	1	KIT POWER CABLE REPLACES 3016943
12	3048137	1	LABEL DANGER, REAR
13	3052071	2	BAG 40X24, WOVEN PP, WHITE
14	3052794	1	HOPPER ASSEMBLY PRO4000
15	3053387	1	CHUTE SWING, ADJUSTABLE, 12VDC
16	3053537	1	HARDWARE KIT PRO4000
17	TS31	6	STRAP, RUBBER TARP 31"

PRO4000CH Assembly

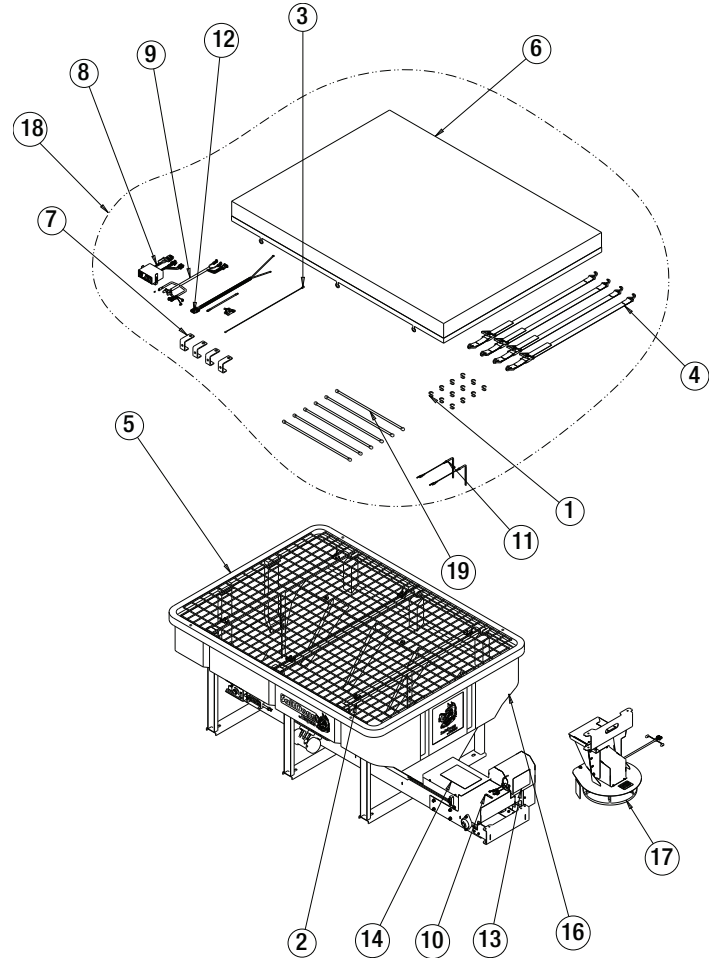

Bill of Materials

ITEM	PART NO.	QTY.	DESCRIPTION
1	9225	12	S-HOOK, 2.5" ZN, TARP STRAP
2	66050	8	SNAPPER PIN, 1/4 X 2, YLW ZINC
3	0203700	1	WIRE ASSEMBLY, 36 LONG
4	1496505	1	HOLD DOWN KIT, SPREADER (4 STRAPS)
5	3012458	2	WIRE MESH, TOP SCREEN
6	3012959	1	TARP, SHPE4000
7	3013589	4	HOOK, TIE-DOWN SHPE4000
8	3057918	1	CONTROLLER SPEED 12 VDC, 60 AMP
9	3030628	1	WIRE HARNESS MAIN
10	3033172	1	DECAL CONNECTION
11	3033174	2	PIN, CHUTE ATTACHMENT
12	3035938	1	KIT POWER CABLE REPLACES 3016943
13	3047964	1	LABEL DANGER, SIDE
14	3048137	1	LABEL DANGER, REAR
15	3052071	2	BAG 40X24, WOVEN PP, WHITE
16	3052786	1	HOPPER ASM 4.0 CU YD 12VDC, CHAIN
17	3053387	1	CHUTE SWING, ADJUSTABLE, 12VDC
18	3053537	1	HARDWARE KIT PRO4000
19	TS31	6	STRAP, RUBBER TARP 31"

PRO6000 Hopper Assembly

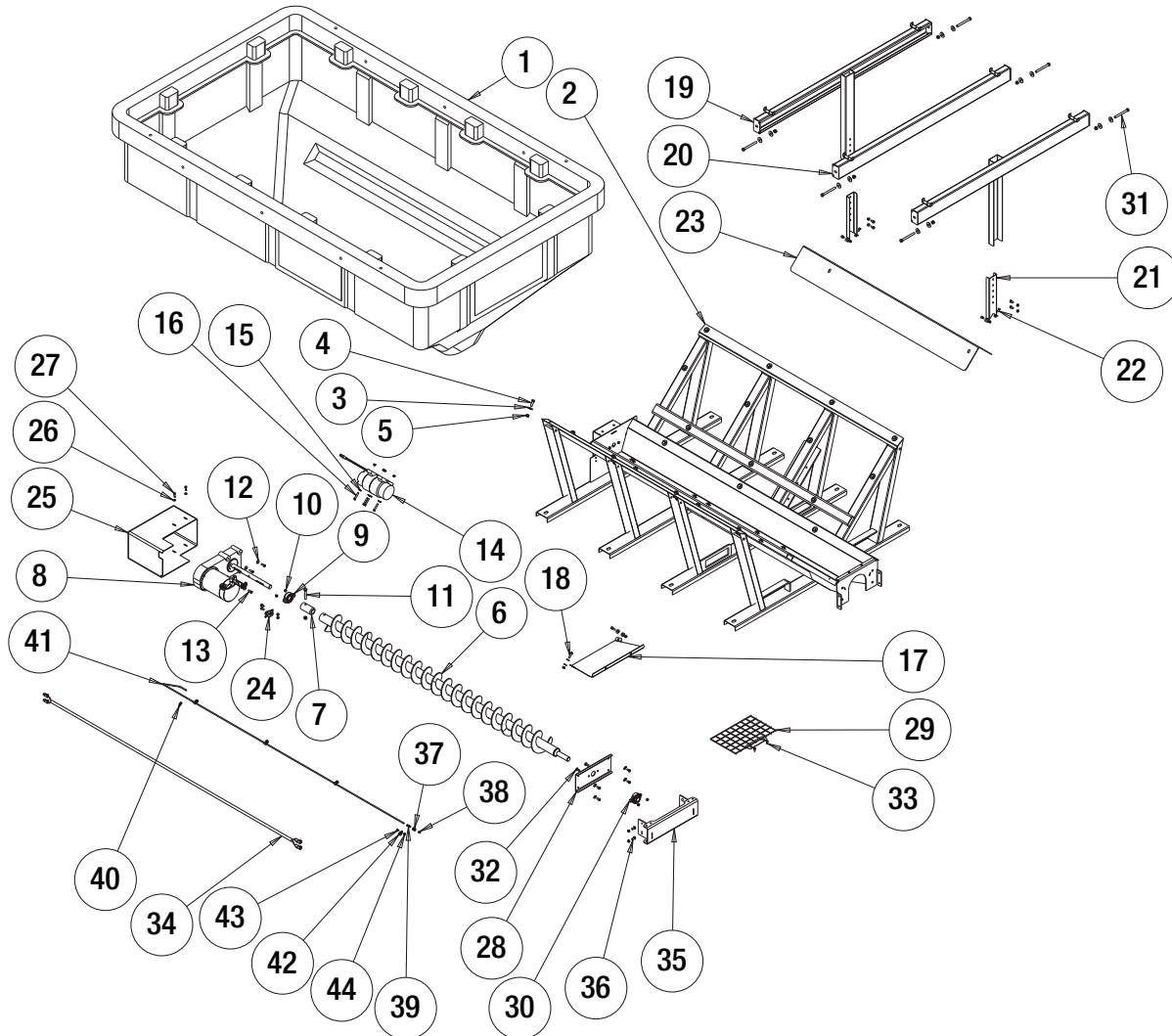

Bill of Materials

ITEM	PART NO.	QTY.	DESCRIPTION
1	3018430	1	HOPPER POLY 6 CU YA
2	3052789	1	TROUGH WELDMENT PRO6000
3	3017858	40	WASHER FLAT .5 ID 1.5 OD SST
4	FCS050013150SS	28	SCREW, HHC-1/2-13 X 1.50 SST
5	FNE050013053SS	35	NUT, NYLOCK 1/2-13 SS
6	3018639	1	AUGER SHPE 6.0 X 4.0 RH
7	3014858	1	SLEEVE, AUGER ADAPTER
8	3013821	1	GEAR MOTOR CONVEYOR 12 VDC
9	1410200	1	BEARING, FLANGED 1-1/8"
10	FNE038016044SS	24	NUT, NYLOCK 3/8-16 X 7/16 SST
11	3001250	1	SCREW, HHC-1/2-13 X 3 SST
12	FWF038100007SS	8	WASHER, FLAT 3/8 USS SST
13	FCS038016100SS	4	SCREW, HHC 3/8-16 X 1 304 SST
14	3019166	1	VIBRATOR 900 LBS 12 VDC
15	3017356	8	WASHER, EXTERNAL TOOTH LOCK 3/8 SS
16	3007066	4	SCREW, HHC-3/8-16 X 2 SST
17	3012607	1	COVER DISCHARGE
18	FCS038016150SS	2	SCREW, HX HD CAP 3/8-16 X 1-1/2 SST
19	3018855	2	SCREEN BRACKET WELDMENT
20	3019795	1	SCREEN SUPPORT WELDMENT
21	3019163	2	HANGER, INVERTED VEE
22	FCS038016075SS	14	SCREW, HHC-3/8-16 X 3/4 SST

ITEM	PART NO.	QTY.	DESCRIPTION
23	3019164	1	DEFLECTOR, INVERTED VEE
24	3017121	2	BRACKET, RECEPTACLE SZ8 DEUTSCH
25	3019236	1	COVER G MOTOR, AUGER
26	FWF031075006SS	2	WASHER, FLAT, 5/16 X .688 X .065, SST
27	3018701	2	SCREW, HHC 5/16-18 X 1.0 SST FULL THD
28	3052793	1	BRACKET BEARING REAR
29	3019791	1	AUGER COVER WELDMENT
30	9240086	1	BEARING, 1-1/4 FLANGE 2 HOLE
31	3019616	6	SCREW, HEX HEAD CAP 1/2-13 X 5.00 SST
32	FCB037516100SS	2	BOLT, 3/8-16 X 1 CARRIAGE SST
33	3006721	2	SCREW, HEX HD, 5/16-18 X 3/4 GR5 SS
34	3019878	1	EXTENSION WIRE HARNESS 8FT MOTOR
35	3053487	1	CHUTE ATTACHMENT, 4000/6000
36	3014960	4	BOLT, 3/8-16 X 1 CARRIAGE SHORT NECK SST
37	H3309X2	1	CONNECTOR, FEM NPT TO FEM NPT 1/8 X 1/8
38	800	1	GREASE FITTING, 1/8in NPT, STRAIGHT
39	3035347	1	GREASE FITTING 1/4TUBE 1/8 NPT STRAIGHT
40	3035344	1	GREASE FITTING 1/4TUBE 1/4-28 MALE STRAIGHT
41	3053265	1	TUBE GREASE, FRONT BEARING
42	4375	4	CLAMP, HOSE .4375, 9/32 HOLE
43	FCS025020075SS	4	SCREW, CAP 1/4-20 X 3/4 SST
44	FNE025020031SS	4	NUT, NYLOCK, 1/4-20, GR A, SST

PRO6000CH Hopper Assembly

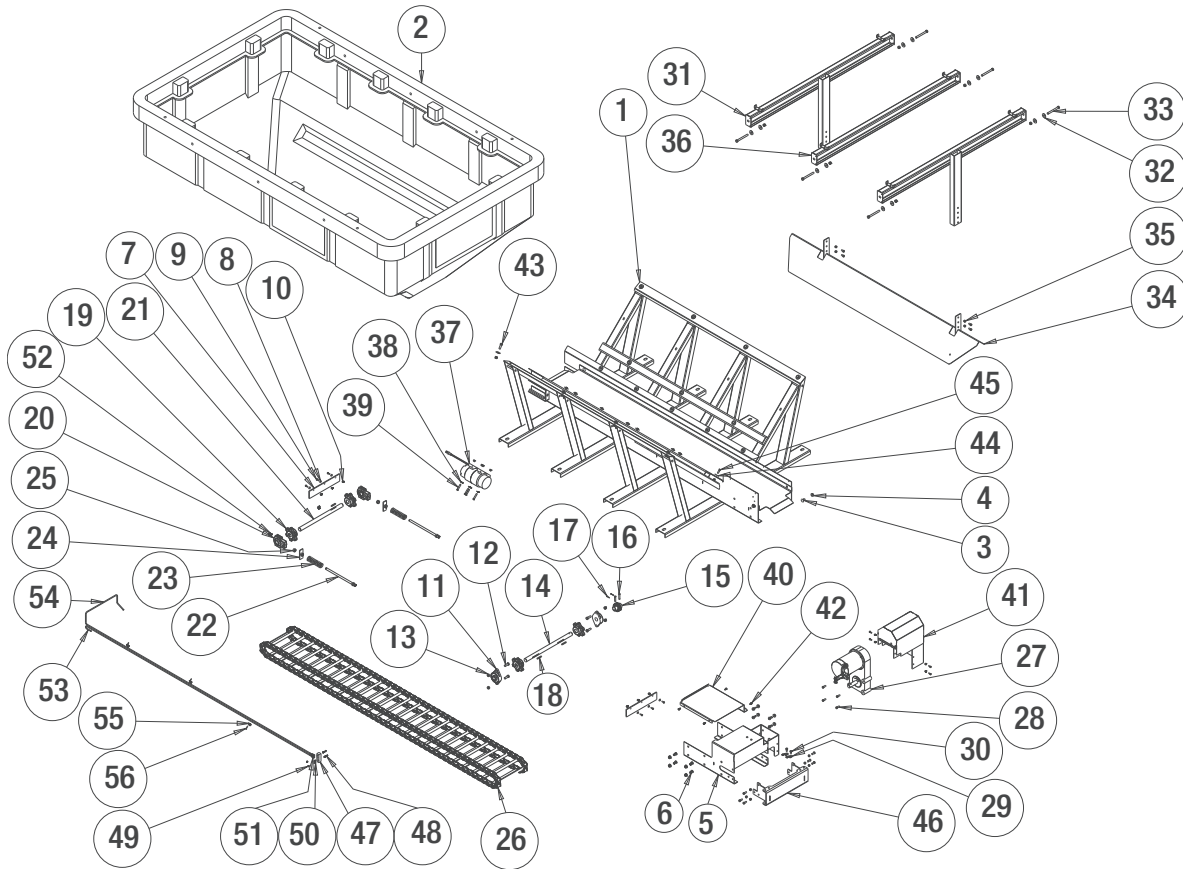

Bill of Materials

ITEM	PART NO.	QTY.	DESCRIPTION
1	3036849	1	TROUGH WELDMENT SHPE6000CH
2	3036857	1	HOPPER POLY 6 CU YA
3	3001522	4	BOLT, CARRIAGE 1/2-13 X 1 SST
4	3001523	12	NUT, HX FLNG-1/2-13 SST
5	3052649	1	MOTOR DECK, WELDMENT
6	3004278	8	SCREW, BTN HD SOC CAP 1/2-13x 1 SST
7	3008872	2	WIPER BELT, HOPPER
8	FWF025063007SS	6	WASHER, FLAT 1/4 SAE SS
9	FCS025020075SS	10	SCREW, CAP 1/4-20 X 3/4 SST
10	FNE025020031SS	10	NUT, NYLOCK, 1/4-20, GR A, SST
11	3008294	2	BEARING, FLANGED
12	3006723	4	SCREW, HEX HD 1/2-13x1.5 GR5 SS
13	FNE050013053SS	24	NUT, NYLOCK 1/2-13 SS
14	3008316	1	SHAFT, SPROCKET DRIVE END
15	3008289	1	COUPLING, DRIVE SHAFT/ GEARBOX
16	1410803	2	PIN, CLEVIS, 3/8 X 2, 1038 ST, YZN
17	FPC013000100	2	COTTER PIN, 1/8 X 1, ZINC
18	KS402	3	KEY, 1/4 X 1/4 X 2
19	3008300	4	SPROCKET, D667H CHAIN
20	3008290	2	BEARING, HEAVY DUTY TAKE-UP
21	3008317	1	SHAFT, IDLER SPROCKET
22	3023046	2	BOLT, WELDED TAKE UP
23	3023022	2	SPRING CHAIN TENSION
24	3031199	2	TAKE-UP NUT WELDMENT
25	FNH063011054SS	2	NUT, HH 5/8-11 X 17/32 HIGH SST
26	3008860	1	CHAIN, 9FT. D667H CONVEYOR
27	3024575	1	GEAR MOTOR CONVEYOR 12 VDC
28	FCS038016100SS	10	SCREW, HHC 3/8-16 X 1 304 SST

ITEM	PART NO.	QTY.	DESCRIPTION
29	3017121	2	BRACKET, RECEPTACLE SZ8 DEUTSCH
30	FCS038016075SS	6	SCREW, HHC-3/8-16 X 3/4 SST
31	3018855	2	SCREEN BRACKET WELDMENT
32	3017858	26	WASHER FLAT .5 ID 1.5 OD SST
33	3019616	6	SCREW, HEX HEAD CAP 1/2-13 X 5.00 SST
34	3036854	1	INVERTED VEE,WELDMENT
35	FNE038016044SS	24	NUT, NYLOCK 3/8-16 X 7/16 SST
36	3019795	1	SCREEN SUPPORT WELDMENT
37	3019166	1	VIBRATOR 900 LBS 12 VDC
38	3017356	4	WASHER, EXTERNAL TOOTH LOCK 3/8 SS
39	3007066	4	SCREW, HHC-3/8-16 X 2 SST
40	3036880	1	COVER, CHAIN
41	3036883	1	WELDMENT, MOTOR COVER
42	3015873	4	SCREW #12-14x.74 SS SELF DRIL HEX WASHER HD
43	FCS050013150SS	14	SCREW, HHC-1/2-13 X 1.50 SST
44	3007115	10	WASHER, FLAT 3/8 X 1.5 X.048 SST
45	FCS038016125SS	10	SCREW, HHC-3/8-16 X 1.25 SST
46	3052651	1	CHUTE ATTACHMENT, PRO4000/6000
47	3035346	1	RIGHT ANGLE JUNCTION BLOCK
48	3035357	2	SCREW SOCKET HD, RND 8-32X 1.50 SST
49	3035358	2	NUT, NYLOCK 8-32 SST, BLACK OXIDE
50	800	2	GREASE FITTING, 1/8in NPT, STRAIGHT
51	3035347	2	GREASE FITTING 1/4TUBE 1/8 NPT STRAIGHT
52	3035345	2	GREASE FITTING 1/4TUBE 1/4-28 MALE 90 DEGREES
53	3036051	1	GREASE HOSE FRONT DR SIDE
54	3036052	1	GREASE HOSE FRONT PS SIDE
55	4375	3	CLAMP, HOSE .4375, 9/32 HOLE
56	3007522	3	SCREW, SHEET MTL #12x1.0 HEX WASHER HD SST

PRO6000 Assembly

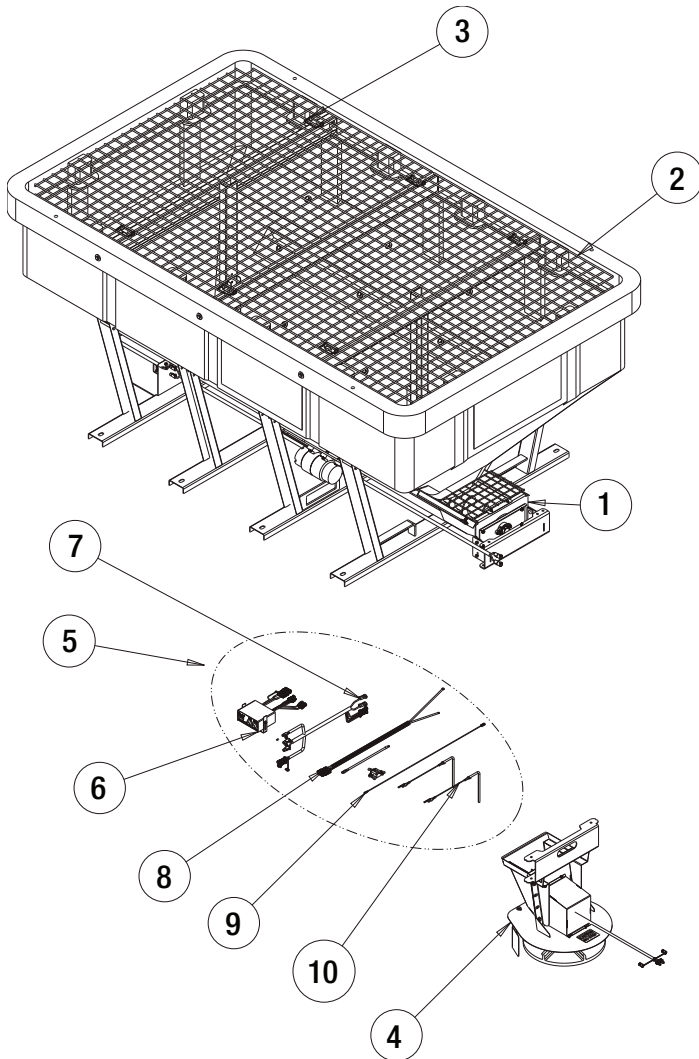

Bill of Materials

ITEM	PART NO.	QTY.	DESCRIPTION
1	3052788	1	HOPPER ASSEMBLY PRO6000
2	3018857	2	SCREEN MESH HALF
3	66070	6	SNAPPER PIN, 1/4 X 3.5, YLW ZINC
4	3053387	1	CHUTE SWING, ADJUSTABLE, 12VDC
5	3053543	1	HARDWARE KIT PRO6000
6	3057918	1	CONTROLLER SPEED 12 VDC, 60 AMP
7	3030628	1	WIRE HARNESS MAIN
8	3035938	1	KIT POWER CABLE REPLACES 3016943
9	0203700	1	WIRE ASSEMBLY, 36 LONG
10	3033174	2	PIN, CHUTE ATTACHMENT
11	3052071	1	BAG 40X24, WOVEN PP, WHITE

PRO6000CH Assembly

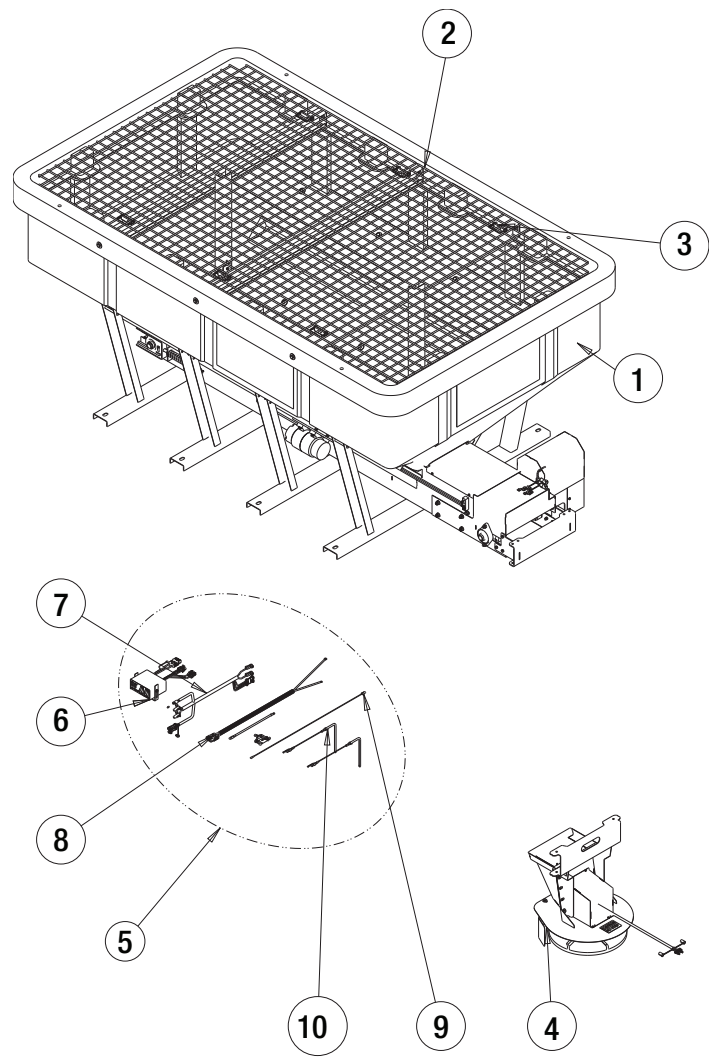

Bill of Materials

ITEM	PART NO.	QTY.	DESCRIPTION
1	3052787	1	HOPPER ASM PRO6000CH
2	3018857	2	SCREEN MESH HALF
3	66070	6	SNAPPER PIN, 1/4 X 3.5, YLW ZINC
4	3053387	1	CHUTE SWING, ADJUSTABLE, 12VDC
5	3053543	1	HARDWARE KIT PRO6000
6	3057918	1	CONTROLLER SPEED 12 VDC, 60 AMP
7	3030628	1	WIRE HARNESS MAIN
8	3035938	1	KIT POWER CABLE REPLACES 3016943
9	0203700	1	WIRE ASSEMBLY, 36 LONG
10	3033174	2	PIN, CHUTE ATTACHMENT
11	3052071	1	BAG 40X24, WOVEN PP, WHITE



www.buyersproducts.com
Phone (440) 974-8888
Fax 800-841-8003

PRO SERIES SPREADER WARRANTY INFORMATION

This warranty replaces all previous warranties and no employee of this company is authorized to extend additional warranties, or agreements, or implications not explicitly covered herein.

Buyers Products Company warrants all parts of the product to be free from defects in material and workmanship for a period of two (2) years. Parts must be properly installed and used under normal conditions. Normal wear is excluded.

Any part, which has been altered, including modifications, misuse, accident, or lack of maintenance will not be considered under this warranty.

The sole responsibility of Buyers Products Company under this warranty is limited to repairing or replacing any part(s), which are returned, prepaid, 30 days after such defect is discovered, and returned part(s) are found to be defective by Buyers Products Company.

Authorization from Buyers Products Company must be obtained before returning any part. The following information must accompany defective parts returned to Buyers Products Company: RMA #, spreader model, serial number, date installed, and distributor from whom purchased.

Buyers Products Company shall not be liable for damage arising out of failure of any unit to operate properly, or failure, or delay in work, or for any consequential damages. No charges for transportation or labor performed on any part will be allowed under this warranty.