



MM00197-Tractor Toddler Swing

ASSEMBLY

Before you start, observe the following statements and warnings to reduce the likelihood of serious or fatal injury.

- This swing come fully assembled — upon receipt check all parts including bucket, ropes, straps, buckles and spring clips for any fractures, breaks, sharp edges, rust, or other signs of damage or deterioration and for any missing parts before moving on to the installation section of the manual.
- DO NOT use swing if any damage or deterioration is detected or missing parts. Contact point of purchase retailer or M&M Sales Enterprises, Inc. Never substitute parts.
- Please keep instructions for future reference.

AGES
9-36
MONTHS

SAFETY
RATED
50
LBS



INSTALLATION

SWING SET OR OTHER HORIZONTAL BEAM ASSEMBLY:

To attach swing to an existing swing set do so by removing a swing or playground element from the existing set and attach the two spring clips to the swing support hook hardware installed on equipment. (See Figure: 1)

TREE LIMB OR CROSS BAR ASSEMBLY:

First test the tree limb or cross bar to ensure that it is secure, it will support at least 50 lbs., is over level ground, has a minimum height of 7 feet and is no less than 6 feet on all sides from vertical elements. Swing should have a clearance of at least 1.5 times the total length of all the rope measured from the tree limb/horizontal beam to the spring clips attachment point. (See Figure: 2)

GENERAL INSTRUCTIONS:

- Do not install home playground equipment over concrete, asphalt, packed earth, grass, carpet or any other hard surface — A fall onto a hard surface can result in serious injury or death to the equipment user.
- To prevent serious injury, equipment must not be used until properly installed.

ADJUST SWING HEIGHT

- Adjust swing hanging length so platform is parallel with ground. Bottom of swing should be no more than 24 inches and no less than 18 inches from the ground.
- Ensure that the swing hangs horizontal after adjustment of the ropes.
- Never add extra length to chain or rope. The chains or ropes provided are the maximum length designed for the swinging element(s).

SECURE YOUR CHILD

1. Place your child in the swing, then place the safety belt over your child's lap and snap the connectors together. (See Figure: 3)
2. Tighten belt by pushing the anchor end of the belt up through the buckle, creating a loop. Pull the free end of the belt to secure it in place. Repeat until the belt fits snugly around your child's waist. Do not over tighten. (See Figure: 4)
3. To loosen the belt push the free end of the belt up through the buckle, creating a loop, then pull the anchor end of the belt.

SELECTIVE PROTECTIVE SURFACING

One of the most important things you can do to reduce the likelihood of serious head injuries is to install shock-absorbing protective surfacing under and around your play equipment. The protective surfacing should be applied to a depth that is suitable for the equipment height in accordance with ASTM F1292. There are different types of surfacing to choose from; whichever product you select, follow these guidelines (See figure 5 and 6):

NOTE—Do not install home playground equipment over concrete, asphalt, or any other hard surface. A fall onto a hard surface can result in serious injury to the equipment user. Grass and dirt are not considered protective surfacing because wear and environmental factors can reduce their shock absorbing effectiveness. Carpeting and thin mats are generally not adequate protective surfacing. Ground level equipment such as a sandbox, activity wall, playhouse or other equipment that has no elevated play surface does not need any protective surfacing.

LOOSE-FILL MATERIALS

- Maintain a minimum depth of 9 in. of loose-fill materials such as wood mulch/ chips, engineered wood fiber (EWF), or shredded/recycled rubber mulch for equipment up to 96 in. high; and 9 in. of sand or pea gravel for equipment up to 60 in. high. NOTE: An initial fill level of 12 in. will compress to about a 9 in. depth of surfacing over time. The surfacing will also compact, displace, and settle, and should be periodically refilled to maintain at least a 9 in. depth.
- Use a minimum of 6 in. of protective surfacing for play equipment less than 48 in. in height. If maintained properly, this should be adequate. (At depths less than 6 in., the protective material is too easily displaced or compacted.)
- Use containment, such as digging out around the perimeter and/or lining the perimeter with landscape edging. Don't forget to account for water drainage.
- Check and maintain the depth of the loose-fill surfacing material. To maintain the right amount of loose-fill materials, mark the correct level on play equipment support posts. That way you can easily see when to replenish and/or redistribute the surfacing.
- Do not install loose fill surfacing over hard surfaces such as concrete or asphalt.

POURED-IN-PLACE SURFACES OR PRE-MANUFACTURED RUBBER TILES

You may be interested in using surfacing other than loose-fill materials – like rubber tiles or poured-in-place surfaces.

NOTE: Continued on Back Side

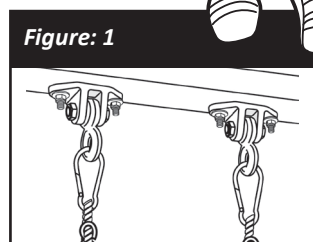

Figure: 1

**THIS SWING
COMES FULLY
ASSEMBLED
AND READY
TO HANG.**

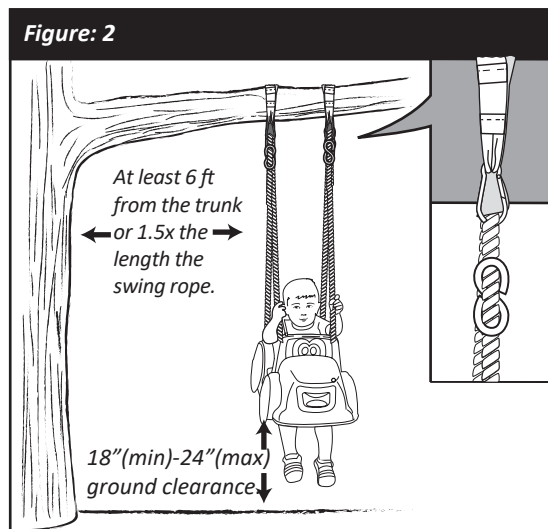

Figure: 2

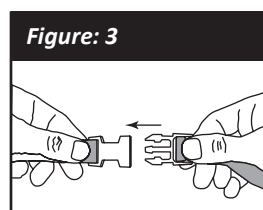

Figure: 3

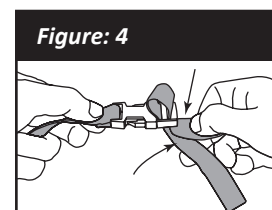

Figure: 4

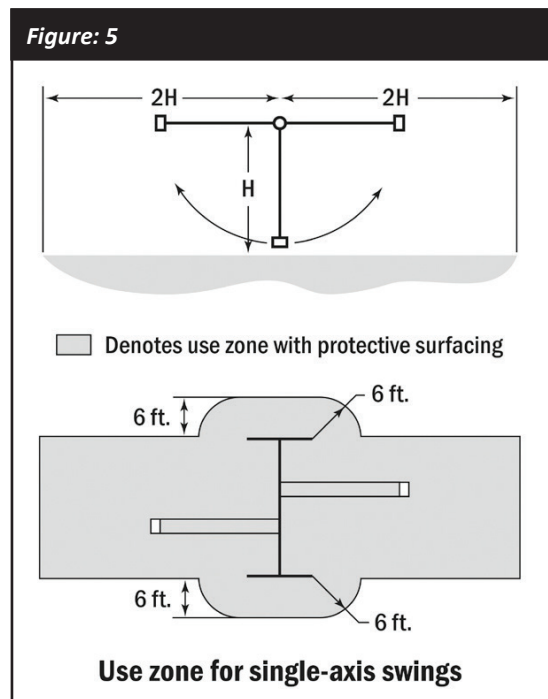

Figure: 5

Use zone for single-axis swings

- Installations of these surfaces generally require a professional and are not “do-it-yourself” projects.
- Review surface specifications before purchasing this type of surfacing. Ask the installer/ manufacturer for a report showing that the product has been tested to the following safety standard: ASTM F1292 Standard Specification for Impact Attenuation of Surfacing Materials within the Use Zone of Playground Equipment. This report should show the specific height for which the surface is intended to protect against serious head injury. This height should be equal to or greater than the fall height-vertical distance between a designated play surface (elevated surface for standing, sitting, or climbing) and the protective surfacing below-of your play equipment.
- Check the protective surfacing frequently for wear.

PLACEMENT

Proper placement and maintenance of protective surfacing is essential. Be sure to:

- Extend surfacing at least 72 in. from the equipment in all directions.
- For to-and-fro swings, extend protective surfacing in front of and behind the swing to a distance equal to twice the height of the top bar from which the swing is suspended.
- For tire swings, extend surfacing in a circle whose radius is equal to the height of the suspending chain or rope, plus 6 feet in all directions.

OPERATION INSTRUCTIONS

- An adult should supervise play on this product for children of all ages.
- Only for family residential domestic use.
- Designed for single rider. LIMIT: 1 child per swing.
- Maximum fall height 6.5 ft. (determined by swing pivot point, maximum hanging rope length and 24 in. above ground surface).

OPERATION WARNING:

Riders should be dressed appropriately including wearing well-fitting shoes that fully protect feet. Remove articles before swinging that create hazards when they get tangled and caught (examples include ponchos, scarves, and other loose-fitting clothing, bike or sports helmets). Adhere to the following guidelines for operation: Do not swing the swing higher than hook attachment (**See Figure: 7**) • Remove rider from the swing only after it has completely stopped • Do not twist swing chains or ropes or loop them over the top support bar since this may reduce the strength of the chain or rope • Avoid swinging empty seats • Do not walk close to, in front of, or behind, or between moving items (**See Figure: 8**) • Rider should sit in center of the swing with full weight in the seat • Do not use the equipment in a manner other than intended • Do not attach items to the playground equipment or support structure that the swing is attached to that are not specifically designed for use with the equipment, such as, but not limited to, jump ropes, clothesline, pet leashes, cables and chain as they may cause a strangulation hazard • Do not climb swing when it is wet • When the swing is in direct sunlight, check that seating surface is not too hot.

MAINTENANCE INSTRUCTIONS

MAINTENANCE WARNING: Failure to carry out these checks and inspections could result in a fall or injury. Owners shall be responsible for maintaining the legibility of the warning labels.

AT THE BEGINNING OF EACH PLAY SEASON:

- Check all moving parts including swing seat, ropes, cables, and chains for excessive wear, fractures, breaks, sharp edges, rust, or other deterioration. Replace as needed.
- Treat ropes with a Teflon-based lubricant.
- Tighten all hardware.
- Check metal parts for rust. If found, sand and repaint using a non-lead-based paint meeting the requirements of 16 CFR 1303.
- Reinstall any plastic parts, such as swing seat or any other items that were removed for the cold season.
- Rake and check depth of loose fill protective surfacing materials to prevent compaction and maintain appropriate depth. Replace as necessary.

(1) ONCE A MONTH DURING PLAY SEASON:

- Check all moving parts including swing seats, ropes, cables, and chains for wear, rust, or other deterioration. Replace as needed.

(2) TWICE A MONTH DURING PLAY SEASON:

- Treat ropes with a Teflon-based lubricant.
- Tighten all hardware.
- Rake and check depth of loose fill protective surfacing materials to prevent compaction and maintain appropriate depth. Replace as necessary.
- Check all moving parts including swing seats, ropes, cables, and chains for wear, rust, or other deterioration. Replace as needed.

AT THE END OF EACH PLAY SEASON OR WHEN THE TEMPERATURE DROPS BELOW 32°F:

- Remove plastic swing seats and other items and take indoors or do not use.
- Rake and check depth of loose fill protective surfacing materials to prevent compaction and to maintain appropriate depth. Replace as necessary.

SWING DISPOSAL: When you are ready to dispose of swing, make sure that all swing components are disposed of in accordance with local waste ordinances. Swing should be disassembled and disposed of in such a way that no unreasonable hazards exist at the time the swing is discarded.

SAFETY INFORMATION: To reduce the likelihood of injury please follow the guidelines as outlined in this instruction manual. You can visit our website www.mandmsalesinc.com to review the instruction manual in the future or keep this instruction sheet for reference: MM00197 Tractor Toddler Swing Instruction Manual. The installation instructions above are reflective of the U.S. Consumer Product Safety Commission’s Outdoor Playground Safety Handbook. For a complete description of installation instructions and warnings for outdoor playground equipment you can visit our website www.mandmsalesinc.com to link to the current CPSC handbook and review in its entirety.

Our products are tested to ensure safety and compliance with Consumer Product Safety Improvement Act of 2008 (CPSIA) including specifications for lead paint and phthalates and ASTM International F1148 Standard Consumer Safety Performance Specifications.

CALIFORNIA PROPOSITION 65 WARNING: THIS PRODUCT CONTAINS CHEMICALS KNOWN TO THE STATE OF CALIFORNIA TO CAUSE CANCER AND BIRTH DEFECTS OR OTHER REPRODUCTIVE HARM.

Figure: 6

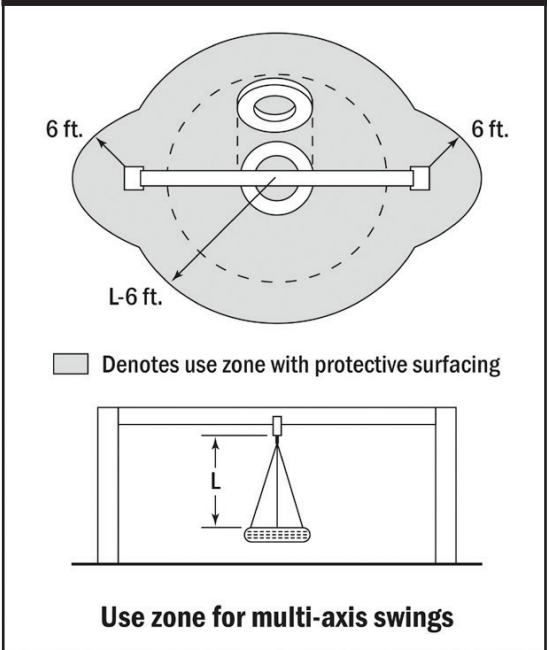
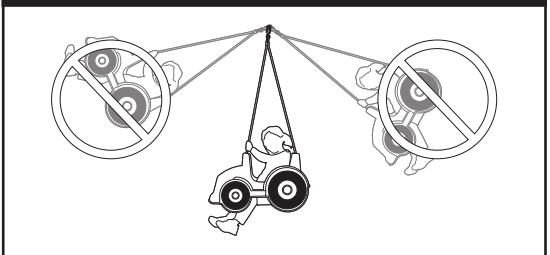
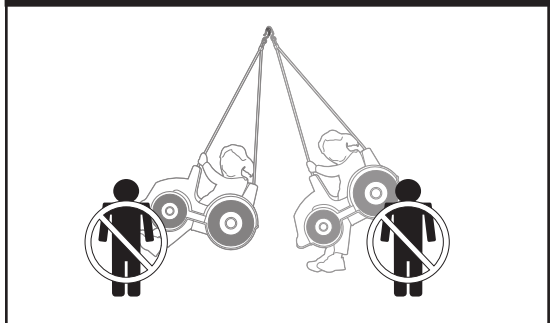

Figure: 7



NEVER SWING HIGHER THAN HOOK ATTACHMENT

Figure: 8



DO NOT WALK IN FRONT OR BEHIND SWING WHILE IN MOTION.



M&M SALES ENTERPRISES, INC.

1300 Synergy Court, Dubuque, IA 52002 | 877-242-0154 www.mandmsalesinc.com

INSPIRING *outdoor* ADVENTURES