



AmgoodSupply

Thank you for purchasing our product!

Issues with your order? Give us a chance to make things right.
Do not return this item back to the store. Contact our friendly customer service department with any problems, comments or concerns.
Replacements for missing or damaged parts are shipped within 1 business day.

Email: **Support@AmGoodSupply.com**

Please check out our other products

Stainless Steel Work Tables
Equipment Stands
Stainless Steel Shelves
Commercial & Utility Sinks
Bakery Racks
Hood Filters
Storage Shelving
Utility Carts
Dunnage Rack
Commercial Floor Strainers
Grease Traps

AmGood Supply is a leading manufacturer and distributor of stainless steel and metal products for commercial and residential applications.

Our customers include homeowners, restaurants, retail and manufacturing businesses, non-profits, as well as state, local, and federal government agencies.

WWW.AMGOODSUPPLY.COM

Work Table Assembly Instructions

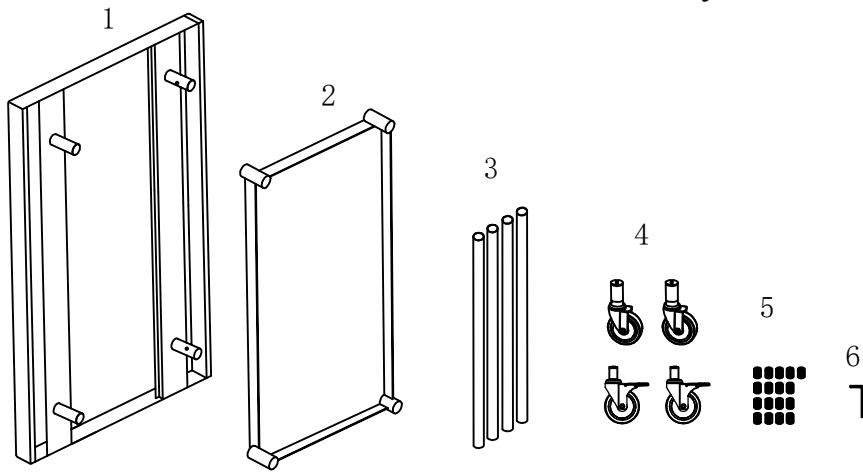

- | |
|-------------------|
| Top Shelf (1) |
| Lower Shelf (1) |
| Legs (4) |
| Casters (4) |
| Allen Screws (17) |
| Allen Wrench (1) |

Unpack and check to make sure all contents are complete. Please follow the steps and instructions below.

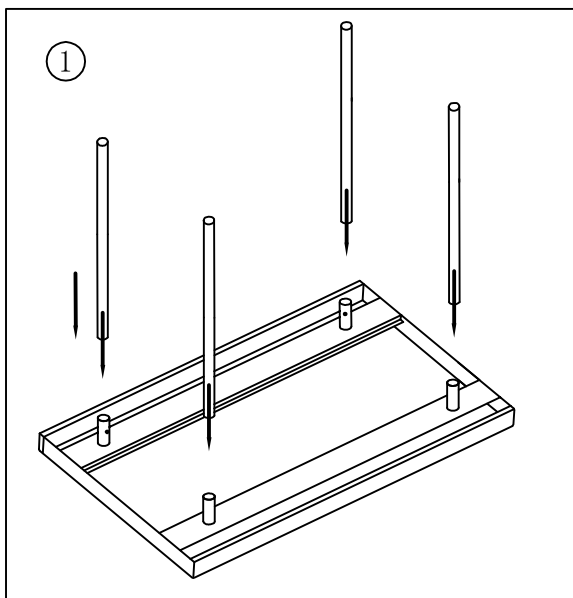

1. Turn the top shelf upside onto the floor
Place the carton top underneath for padding to avoid scratching.

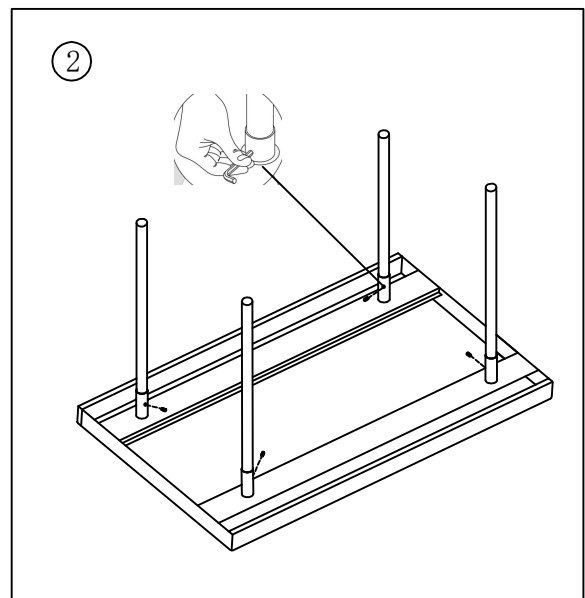

2. Assembly four legs
Insert four legs into the leg sockets, then partially fasten the Allen screws.

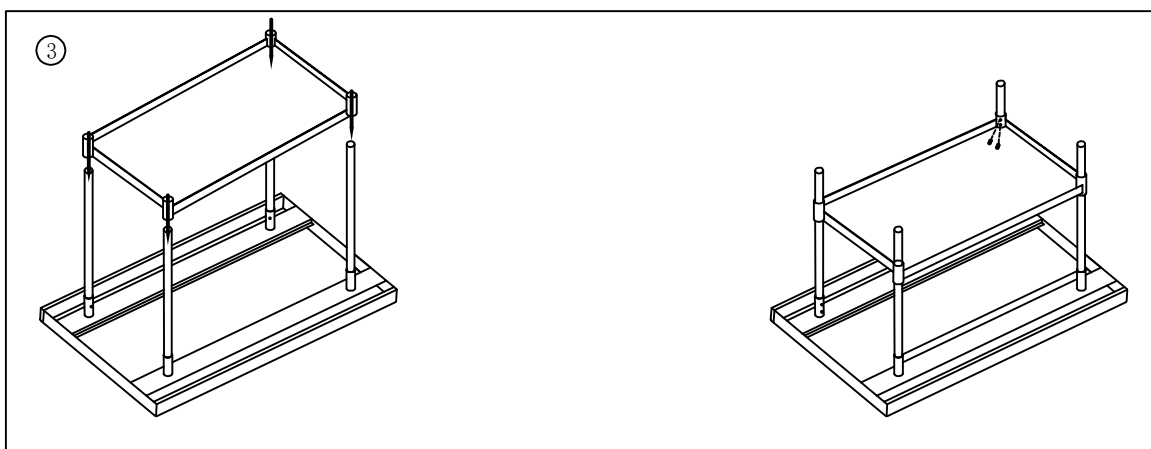

3. Assembly the lower shelf
Slide the lower shelf into the legs to desired height, at least 9", so that the lower portion of the shelf will sit at least 6" above the floor when assembled. Finish tightening all Allen screws.

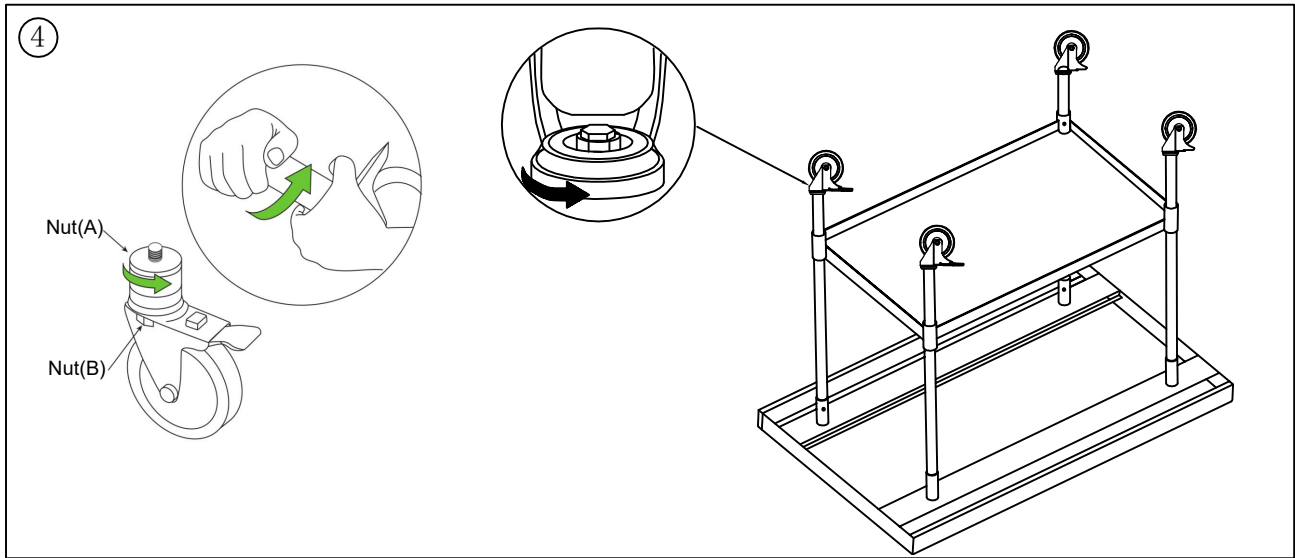

4. Caster Assembly

Insert the caster into the leg, if the rubber part is too large for the socket, please loosen the top nut (A) by moving it counter clockwise. Once the stem successfully inserted into the leg, please use a wrench to tighten nut (B) by moving it clockwise until the caster is firmly secured inside the leg.

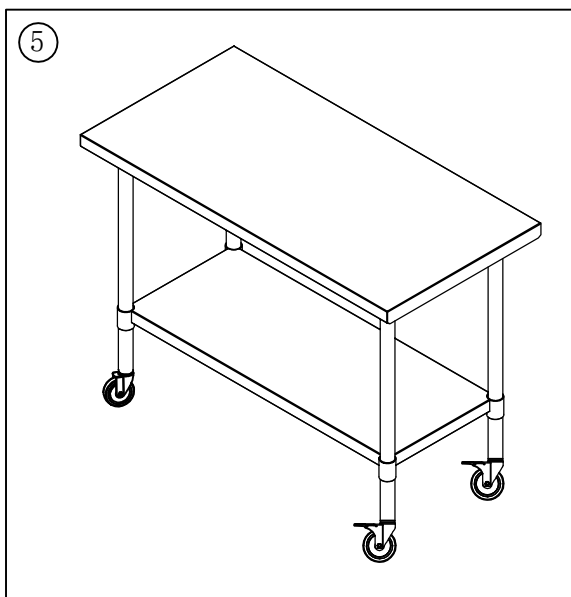

5. Turn over the completed equipment stand and it is now ready to use.

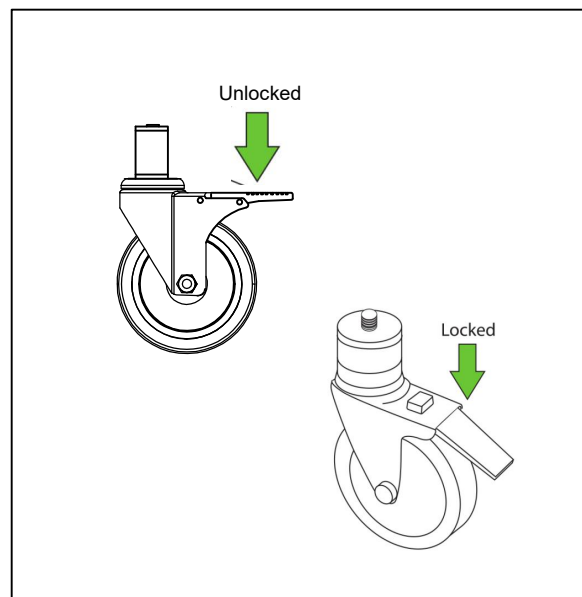

6. Use the caster brakes

Push down the brake if you want to lock the caster, lift it up if you want it unlocked.

WARNING

1. Do not use the equipment stand if any screws are missing.
2. Level adjust the stand when there is no equipment or items on the top under shelf.
3. Mobile stands must be used with restraining device.