

# 12x16 Hardtop Gazebo / Pavillon De Jardin A Auvent Rigide

Item/Article #: A102009141

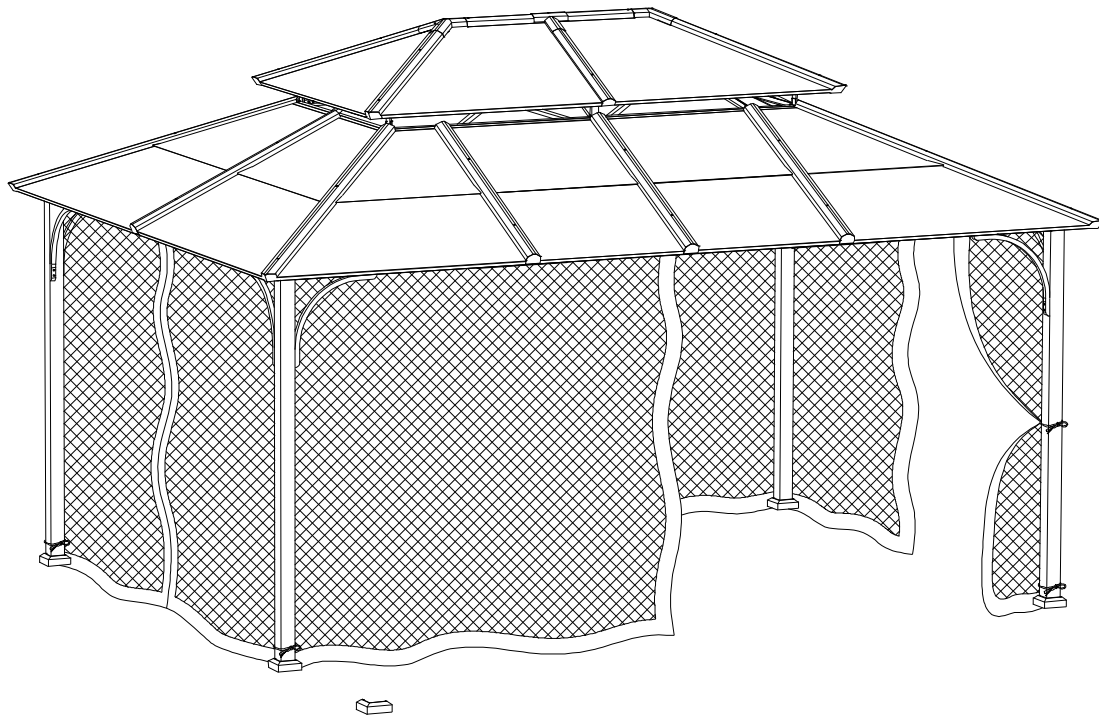

**Questions? Issues? Missing Part? Professional  
Installation Service?**

**Contact us at [customer.care@sunjoygroup.com](mailto:customer.care@sunjoygroup.com)**

**Questions? Problèmes? Pièce manquante?**

**Service d'installation professionnel? Contactez-  
nous à [customer.care@sunjoygroup.com](mailto:customer.care@sunjoygroup.com)**



A10200914124

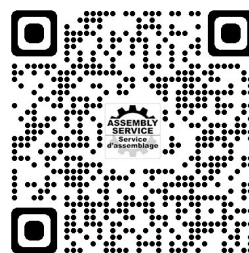

Country of Origin: China  
Pais d'origine: Chine

Production Number: 2024100625  
Numéro de fabrication: 2024100625

## Warnings :

- Any assembly or maintenance of the product must be carried out by adults only. We recommend at least 4 adults. / Tout montage ou entretien du produit doit être effectué uniquement par des adultes. Nous recommandons au moins 4 adultes.
- Please check your state and local regulations prior to purchasing. Some jurisdictions may require permits for installation and use. Some special procedures may be valid in your area. / Veuillez vérifier les réglementations nationales et locales avant d'acheter. Certaines juridictions peuvent exiger des permis pour l'installation et l'utilisation. Certaines procédures spéciales peuvent être valides dans votre région.
- Do not assemble the gazebo on sandy, muddy or loose soil, as stakes do not have enough anchorage in these types of soil. / Ne montez pas la tonnelle sur un sol sablonneux, boueux ou meuble, car les piquets n'ont pas assez d'ancrage dans ces types de sol.
- Install the gazebo on level ground . Stakes are provided to secure the gazebo to the ground./ Installez le belvédère sur un sol plat. Des piquets sont fournis pour fixer la tonnelle au sol.
- If you wish to secure the gazebo to a wood deck or concrete surface, use anchors suited to these surfaces (anchors not included)./Si vous souhaitez fixer le gazebo à une terrasse en bois ou à une surface en béton,utilisez des ancrages adaptés à ces surfaces (ancrages non inclus).
- Some parts may contain sharp edges. Wearing protective gloves is advised. / Certaines pièces peuvent contenir des bords tranchants. Portez des gants de protection si nécessaire.
- Keep children and pets away while setting up the gazebo./Tenez les enfants et les animaux à l'écart de l'abri de jardin pendant son assemblage.
- Check all nuts and bolts periodically to ensure they are tightened./ Assurez-vous périodiquement que tous les écrous et boulons pour s'assurer que les ils sont serrés.
- Snow must be cleared off regularly during snowy days. Remove the snow at the roof top when it is thicker than 2 inches. In order to avoid damage, use a plastic snow rake to remove excessive snow and ice buildup from roof and keep away from falling debris. and removal of fallen debris. /La neige doit être déblayée régulièrement pendant les jours de neige. Enlevez la neige sur le toit lorsqu'elle est plus épaisse que 2 pouces. Afin d'éviter tout dommage, utilisez un râteau à neige en plastique pour enlever l'accumulation excessive de neige et de glace sur le toit et éloignez-vous des chutes de débris. et l'enlèvement des débris tombés.
- This gazebo is intended for decorative and sunshade purposes only and is not designed to withstand harsh weather, including high winds, rain, and snow. / Cet abri de jardin est conçu uniquement pour des fins décoratives et de pare-soleil, et il n'est pas conçu pour résister aux intempéries, notamment les vents violents, la pluie et la neige.
- If any scratches in paint occur, please touch up to prevent rustin / En cas de rayures sur la peinture, veuillez les retoucher pour éviter la rouille.

## Important:

- Please read and understand this manual before any assembly. Before beginning assembly of product, make sure all parts are present. Compare parts with packaging contents list.
  - When assembling wooden parts, do not overtorque the bolts to avoid splitting the wood. See image illustration.
  - Place all parts from the box in a cleared area and position them on the floor in front of you.
  - Remove all packing materials and place them back into the box. Do not dispose of the packing materials until assembly is complete.
  - Read each step carefully before beginning any assembly and make sure you understand each step. If you are missing a part, please email [customer.care@sunjoygroup.com](mailto:customer.care@sunjoygroup.com).
  - Needed for assembly: (The following tools are not included)
- Veuillez lire et bien comprendre ce guide avant de procéder à l'assemblage. Avant de procéder à l'assemblage du produit, assurez-vous que toutes les pièces sont présentes.
  - Lors de l'assemblage de pièces en bois, ne serrez pas trop les boulons afin d'éviter de fendre le bois.
  - Consultez l'illustration dans les schémas. Mettez toutes les pièces de la boîte dans une zone dégagée et positionnez-les sur le sol devant vous.
  - Retirez tous les matériels d'emballage et remettez-les dans la boîte. Ne les jetez pas avant d'avoir terminé l'assemblage.
  - Lisez chaque étape attentivement avant de commencer à assembler et assurez-vous de comprendre bien chaque étape. S'il vous manque des pièces, veuillez envoyer un email à [customer.care@sunjoygroup.com](mailto:customer.care@sunjoygroup.com).
  - Nécessaire pour l'assemblage : (les outils suivants ne sont pas inclus).

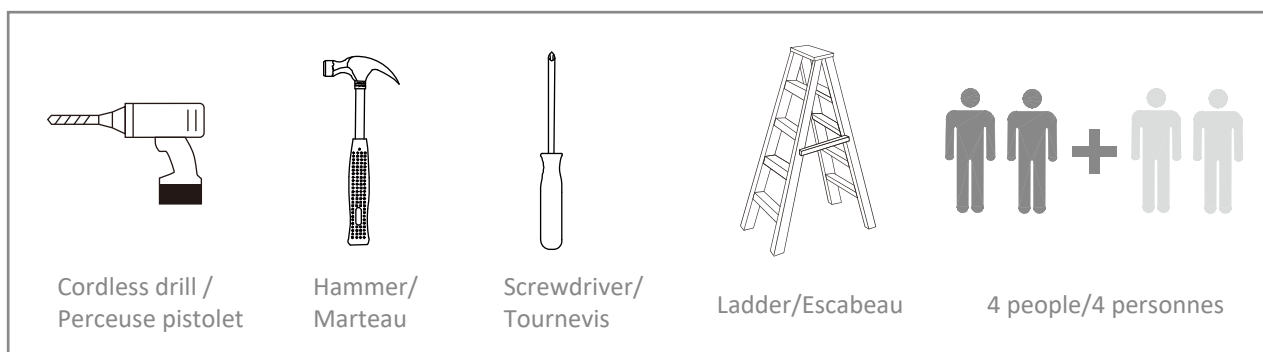

This identifies information that requires special attention. Improper assembly could lead to an unsafe or dangerous condition. / Cette icône identifie de l'information. Utilisez un niveau. Vérifiez avec un équerre. Serrez les boulons. Mesurer la distance.



### Use Level/Utilisez un niveau

Check that set or assembly is properly level before proceeding. / Vérifiez que l'assemblage est d'aplomb avant de procéder à la prochaine étape.



### Square Assembly/Vérifiez avec un équerre

Check that assembly is square before tightening bolts. / Vérifiez que l'assemblage est carré avant de serrez les boulons.

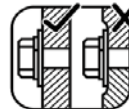

### Tighten Bolts/Serrer les boulons

Do not overtorque mounting bolts. Over-tightening may cause the wood to crack creating splinters and other structural damage. / Ne serrez pas trop les boulons de fixation. Un serrage excessif peut provoquer des fissures dans le bois, créant des éclats de bois et d'autres dommages structurels.



### Measure Distance/Mesurer la distance

**Installation blueprint/  
Plan d'installation**

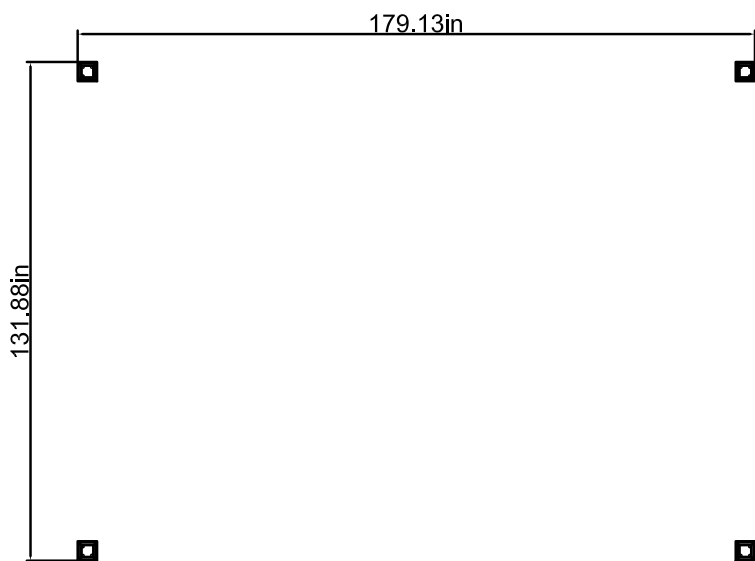



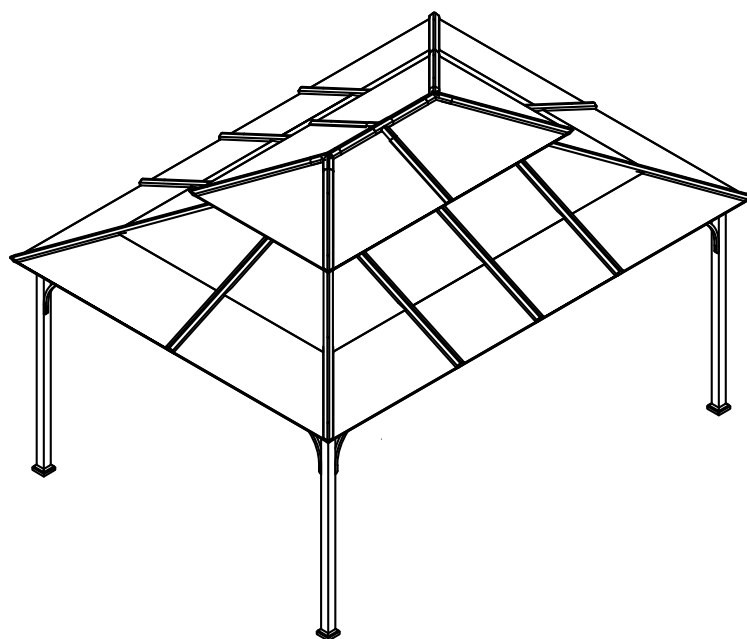
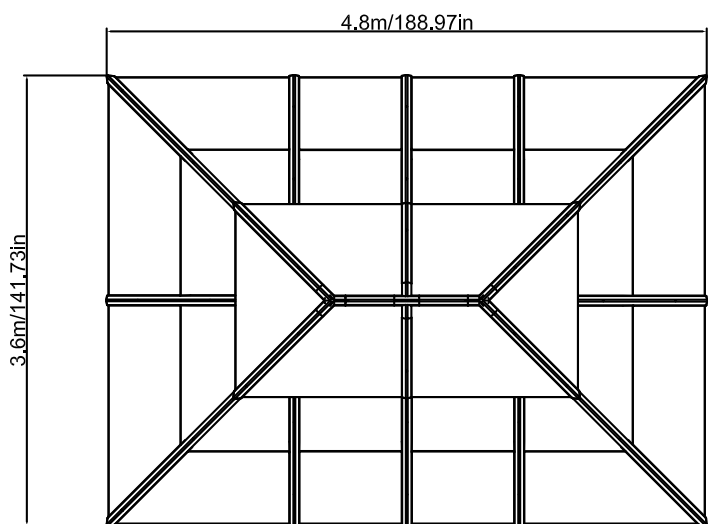
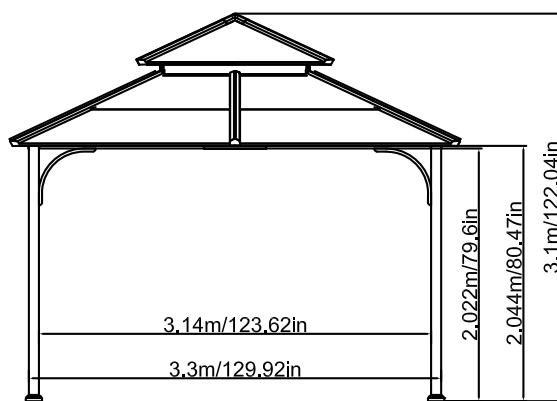
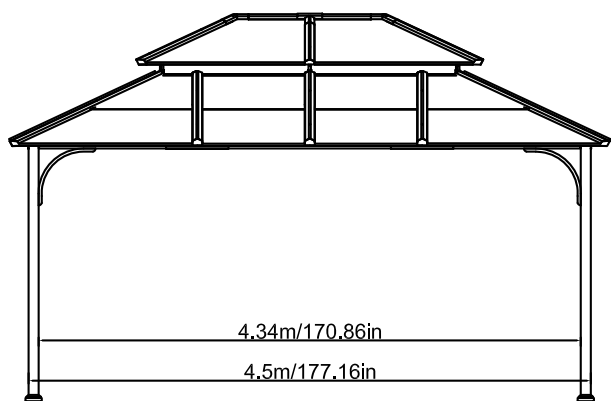



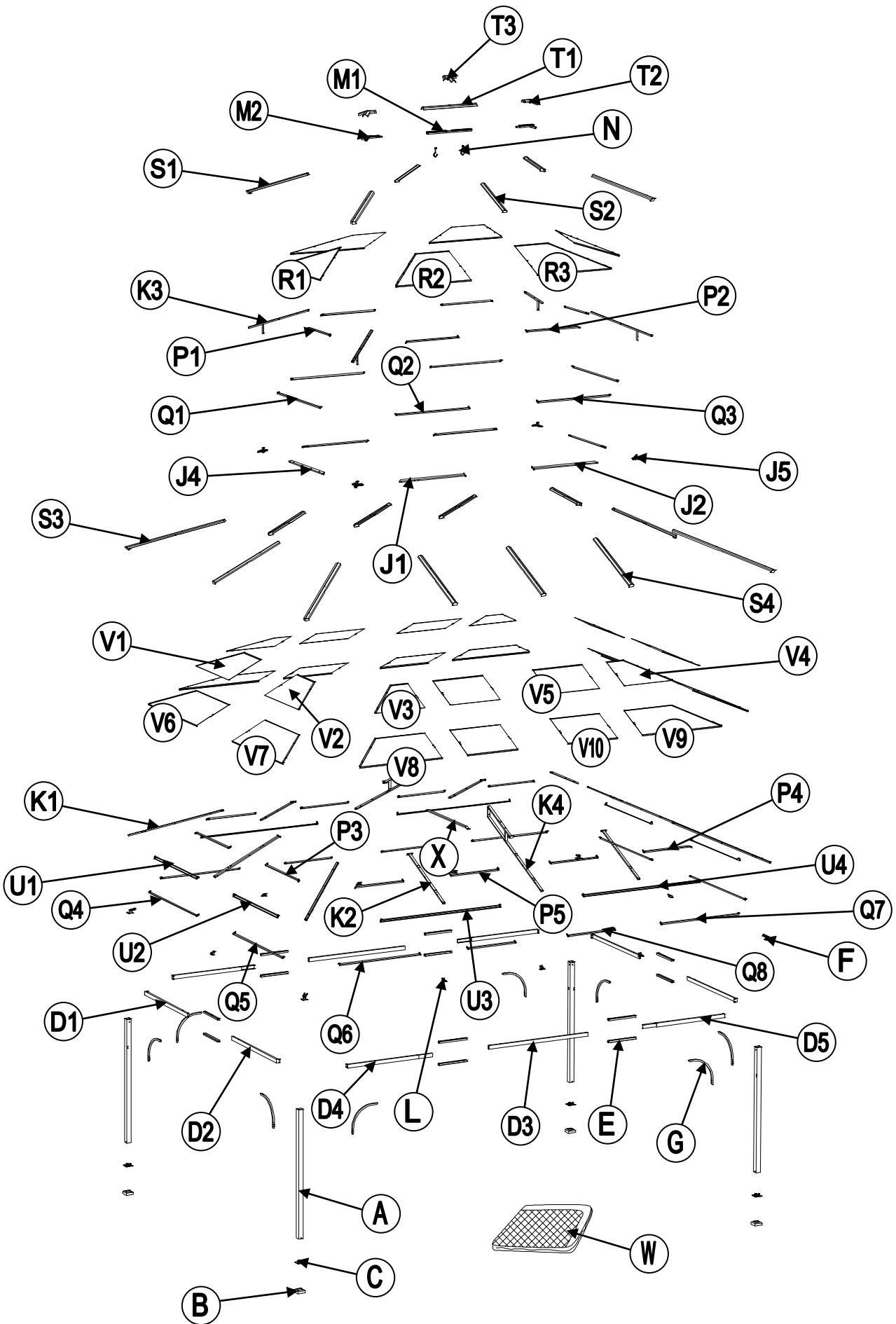

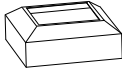
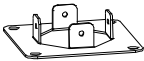

























**Product size effect drawing/  
Dessin d'effet de taille de produit**









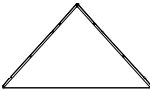

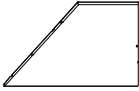





EXPLODED DRAWING/ DESSIN ÉCLATÉ







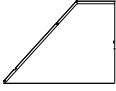
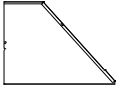

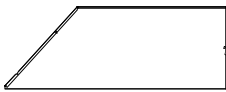

Parts List/Liste de Pièces				
Label/ Étiquette	Part Number/ Numéro de la Pièce	Description	Qty/ Quantité	Part Image/Numéro de la Pièce Diagramme
A	P00020086701	Post/Poteau	4	
B	P00610026503	Base Cover/ Barde de la base	4	
C	P00010025301	Post Base/Base du Poteau	4	
D1	P00040164801	Left Cross Beam (Short Side) / Traverse Gauche(Côté Court)	2	
D2	P00040164901	Right Cross Beam (Short Side)/Traverse Droite (Côté Court)	2	
D3	P00040165502	Middle Cross Beam (Long Side)/Traverse Centrale (Côté Long)	2	
D4	P00040165602	Left Cross Beam (Long Side)/Traverse Gauche(Côté Long)	2	
D5	P00040165702	Right Cross Beam (Long Side) /Traverse Droite (Côté Long)	2	
E	P00050208701	Cross Beam Connector /Connexion de la Traverse	12	
F	P00050208801	Big Roof Rafter Connector /Connexion du Plafond du Grand Toit	4	
G	P00500084101	Brace/Barre de Renfort	8	
J1	P00050210302	Big Roof Long Connector Tube 2/Tuyau de Connexion Long du Grand Toit 2	2	
J2	P00050210202	Big Roof Long Connector Tube 1/Tuyau de Connexion Long du Grand Toit 1	2	
J4	P00050188601	Big Roof Short Frame/ Structure Courte du Grand Toit	2	
J5	P00050209702	Big Roof Corner Frame/ Cadre d'angle de grand toit	4	
K1	P00060287401	Big Roof Rafter/ Chevron du Grand Toit	4	
K2	P00060289802	Big Roof Middle Beam 1/Poutre Centrale du Grand Toit 1	6	

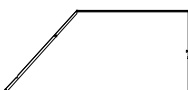
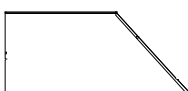
K3	P00060289502	Small Roof Rafter/ Plafond du Petit Toit	4	
K4	P00060295302	Big Roof Middle Beam 2/Poutre Centrale du Grand Toit 2	2	
L	P00050190002	Middle Beam Connector /Connexion de la poutre centrale	8	
M1	P00050209902	Small Roof Connector Tube 1/Tuyau Connecteur du Petit Toit1	1	
M2	P00050210002	Small Roof Connector Tube 2/Tuyau Connecteur du Petit Toit 2	2	
N	P00580015401	Hook/Crochet	2	
P1	P00060288002	Small Roof Small Beam (Short Side)/Petite Poutre du Petit Toit (Côté Court)	2	
P2	P00060289702	Small Roof Long Beam (Long Side)/Poutre Longue du Petit Toit (Côté Long)	4	
P3	P00060288702	Big Roof Small Beam (Short Side)/Petite Poutre du Grand Toit (Côté Court)	4	
P4	P00060254401	Big Roof Short Small Beam/Petite Poutre Courte du Grand Toit	4	
P5	P00060288902	Big Roof Middle Small Beam (Long Side)/Poutre Centrale Petite du Grand Toit(Côté Long)	4	
Q1	P00060287701	Small Roof Short Panel Flashing/Bande d'étanchéité du Panneau Court du Petit toit	2	
Q2	P00060289902	Small Roof Panel Flashing 1(Long Side)/Solin du Panneau du Petit Toit 1(Côté Long)	2	
Q3	P00060290002	Small Roof Panel Flashing 2(Long Side)/Solin du Panneau du Petit Toit 2(Côté Long)	2	
Q4	P00060256503	Big Roof Left Panel Flashing (Short Side)/Solin du Panneau Gauche du Grand Toit (Côté Court)	2	
Q5	P00060256603	Big Roof Right Panel Flashing (Short Side)/Solin du Panneau Droit du Grand Toit(Côté Court)	2	
Q6	P00060290102	Big Roof Panel Flashing 1(Long Side)/Solin du Panneau du Grand Toit 1(Côté Long)	2	
Q7	P00060290202	Big Roof Panel Flashing 2(Long Side)/Solin du Panneau du Grand Toit 2(Côté Long)	2	
Q8	P00060290302	Big Roof Middle Panel Flashing(Long Side)/Solin du Panneau Central du Grand Toit(Côté Long)	4	
R1	P00070138302	Small Roof Roof Panel (Short Side)/Panneau du Petit Toit(Côté Court)	2	

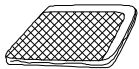
R2	P00070138402	Small Roof Left Roof Panel (Long Side)/Panneau de Toiture Gauche du Petit Toit (Côté Long)	2	
R3	P00070138502	Small Roof Right Roof Panel (Long Side)/Panneau de Toiture Droit du Petit Toit(Côté Long)	2	
S1	P00080042902	Small Roof Rafter Cap/Capuchon du Chevron du Petit Toit	4	
S2	P00080049202	Small Roof Middle Beam Cap /Bâche de la Poutre Centrale du Petit Toit	2	
S3	P00080043905	Big Roof Rafter Cap/Chevron du Grand Toit	4	
S4	P00080049302	Big Roof Middle Beam Cap/Couvert de la Poutre Centrale du Grand Toit	8	
T1	P00090021002	Small Roof Cover 1/ Toiture du petit toit 1	1	
T2	P00090021102	Small Roof Cover 2/ Toiture du petit toit 2	2	
T3	P00080049102	Small Roof Middle Cap/Couvert Central du Petit Toit	1	
U1	P00570055001	Left Mosquito Netting Rod (Short Side)/Tringle Gauche du Filet Moustiquaire (Côté Court)	2	
U2	P00570055101	Right Mosquito Netting Rod (Short Side)/Tringle Droite du Filet Moustiquaire(Côté Court)	2	
U3	P00570040802	Left Long Mosquito Netting Rod/Tringle Longue Gauche du Filet Moustiquaire	2	
U4	P00570040902	Right Long Mosquito Netting Rod/Tringle Longue Droite du Filet Moustiquaire	2	
V1	P00070138602	Big Roof Left Up Roof Panel (Short Side)/Panneau Supérieur Gauche du Grand Toit(Côté Court)	2	
V2	P00070138702	Big Roof Right Up Roof Panel (Short Side) /Panneau Supérieur Droit du Grand Toit(Côté Court)	2	
V3	P00070123303	Big Roof Up Left Roof Panel (Long Side)/Panneau Supérieur Gauche du Grand Toit(Côté Long)	2	
V4	P00070123403	Big Roof Up Right Roof Panel (Long Side)/Panneau Supérieur Droit du Grand Toit(Côté Long)	2	

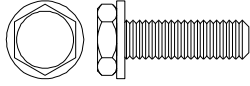
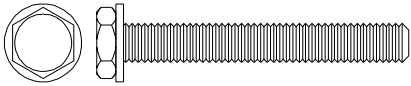
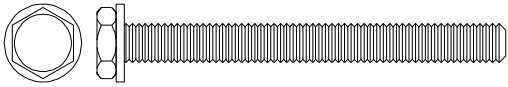
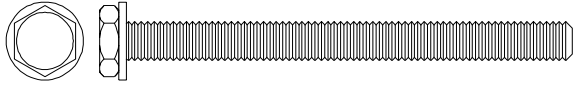
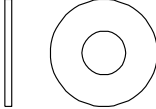
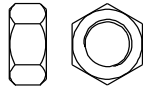
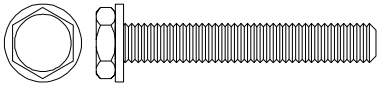

V5	P00070138802	Big Roof Middle Up Roof Panel (Long Side)/ Panneau Supérieur Central du Grand Toit(Côté Long)	4	
V6	P00070123102	Big Roof Low Left Roof Panel (Short Side)/Panneau Inférieur Gauche du Grand Toit (Côté Court)	2	
V7	P00070123202	Big Roof Low Right Roof Panel (Short Side)/ Panneau Inférieur Droit du Grand Toit(Côté Court)	2	
V8	P00070123503	Big Roof Low Left Roof Panel (Long Side)/ Panneau Inférieur Gauche du Grand Toit(Côté Long)	2	
V9	P00070123603	Big Roof Low Right Roof Panel (Long Side)/ Panneau Inférieur Droit du Grand Toit(Côté Long)	2	
V10	P00070138902	Big Roof Middle Low Roof Panel (Long Side)/Panneau Inférieure Central du Grand Toit(Côté Long)	4	
W	P00120030402	Moquito Netting/ Filet Moustiquaire	1	
X	P00500085702	Support Bar 3/Barre de Support 3	1	

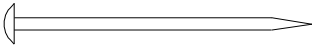
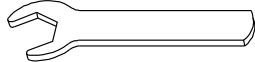
Hardware Pack/Pack Quincaillerie					
Label / Étiquette	Part Number/ Numéro de la Pièce	Description	Qty/ Quantité	Add	Part Image/Numéro de la Pièce Diagrammee
H1	H100010047	Bolt M6*20/ Boulon M6*20	281	15	
H2	H100010058	Bolt M6*50/ Boulon M6*50	66	4	
H3	H100010073	Bolt M6*60/ Boulon M6*60	2	1	
H4	H100010172	Bolt M6*80/ Boulon M6*80	24	2	
H5	H050030001	Flat washer M6/Rondelle Plate M6	26	2	
H6	H040010004	Nut M6/Écrou M6	26	2	
H7	H100010046	Bolt M6*40/ Boulon M6*40	2	1	
HH	H050050018	M6 Rubber Washer/Rondelle en Caoutchouc M6	37	2	
HR	H990050001	Ring/Anneaux	64	4	
HS	H070010003	Stake $\Phi$ 8*180/ Piquet $\Phi$ 8*180	8	0	
HW	H090010017	Wrench M6/ Clé M6	2	0	

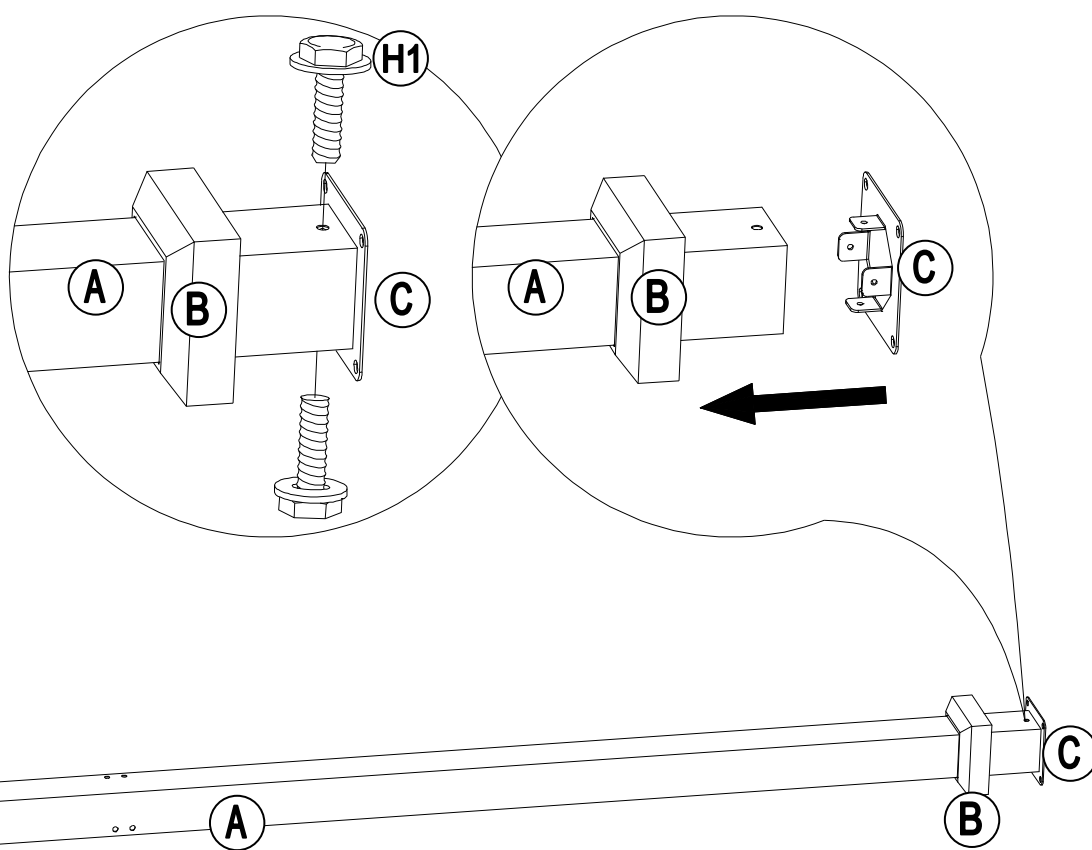
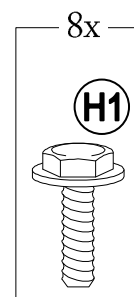
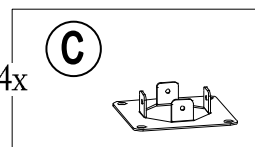
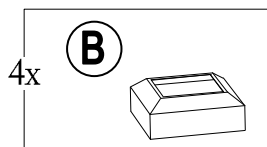
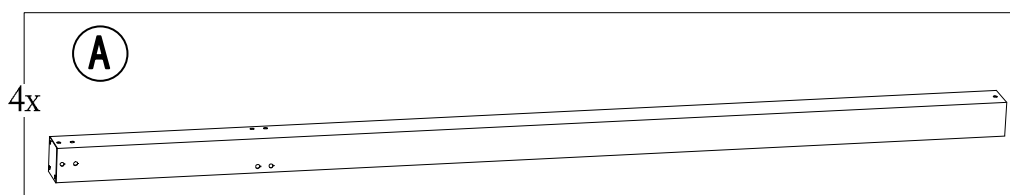
**1**

# 2

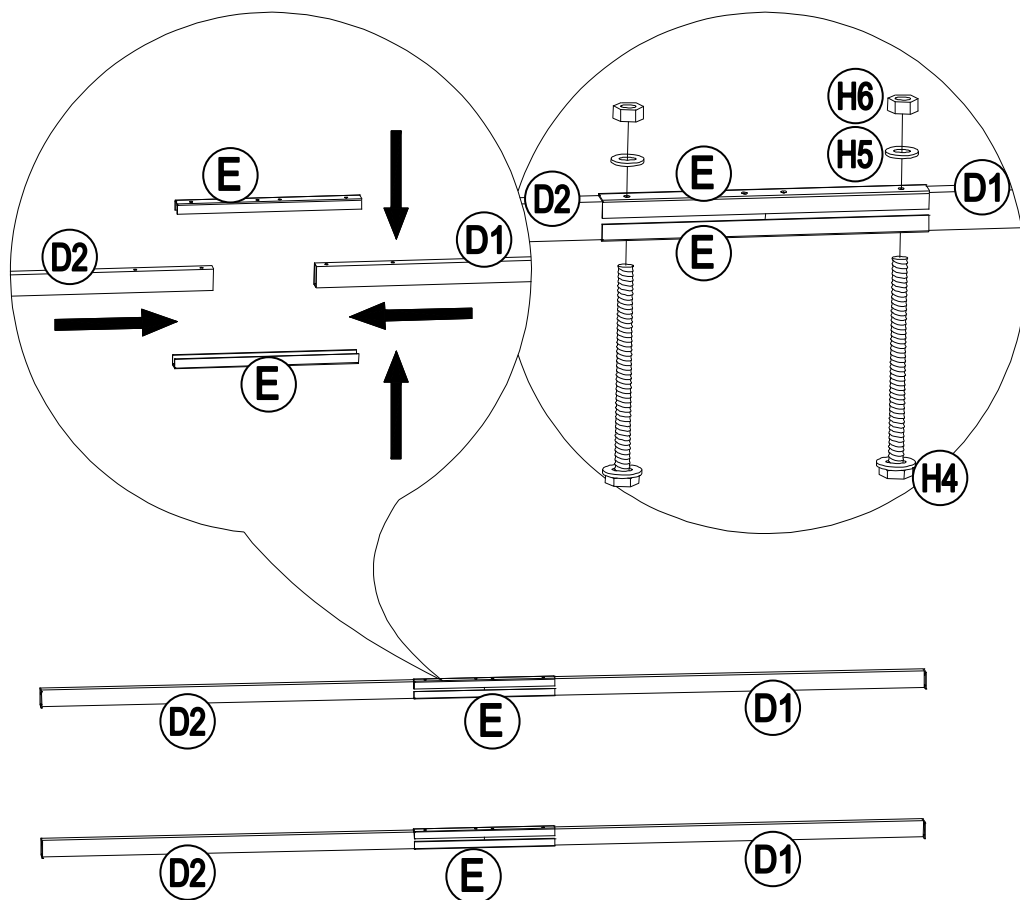
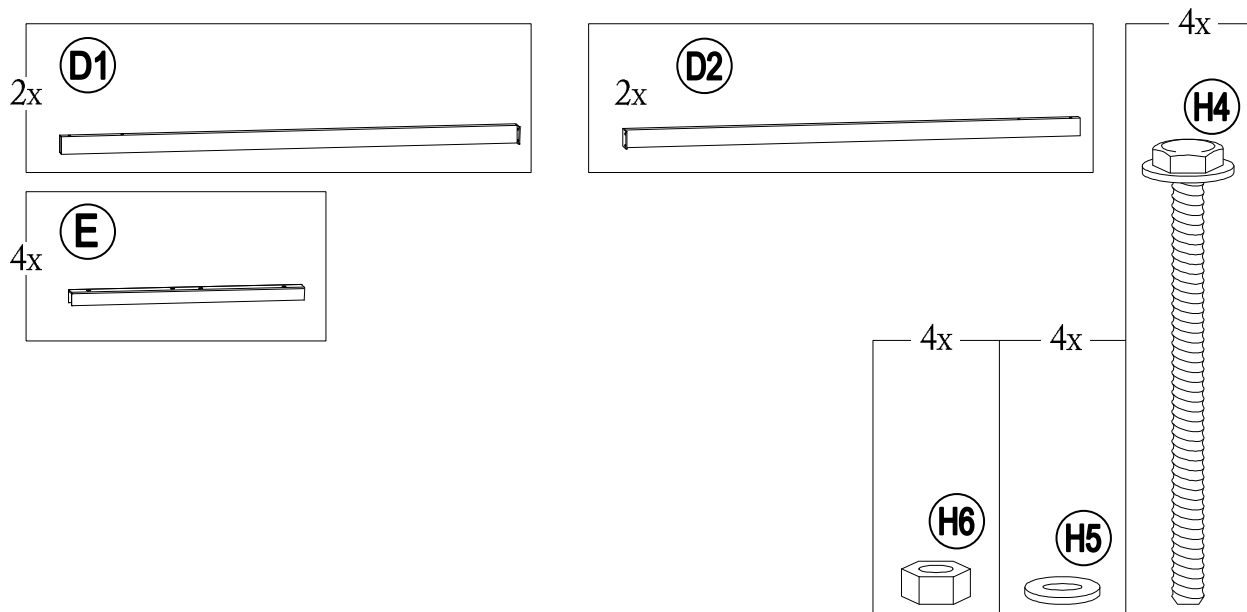

# 3

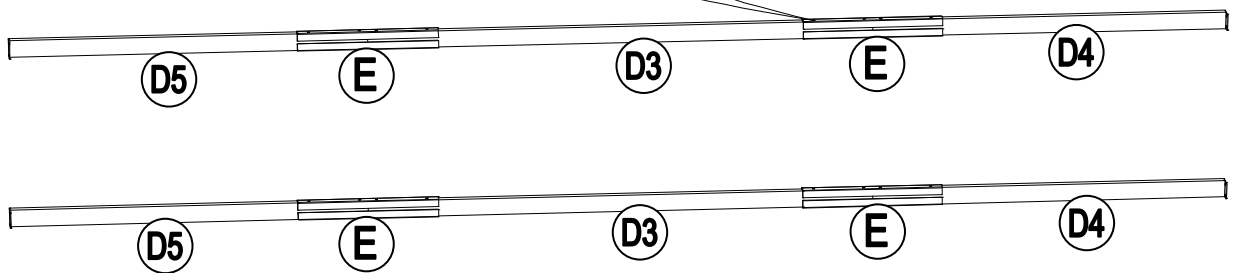
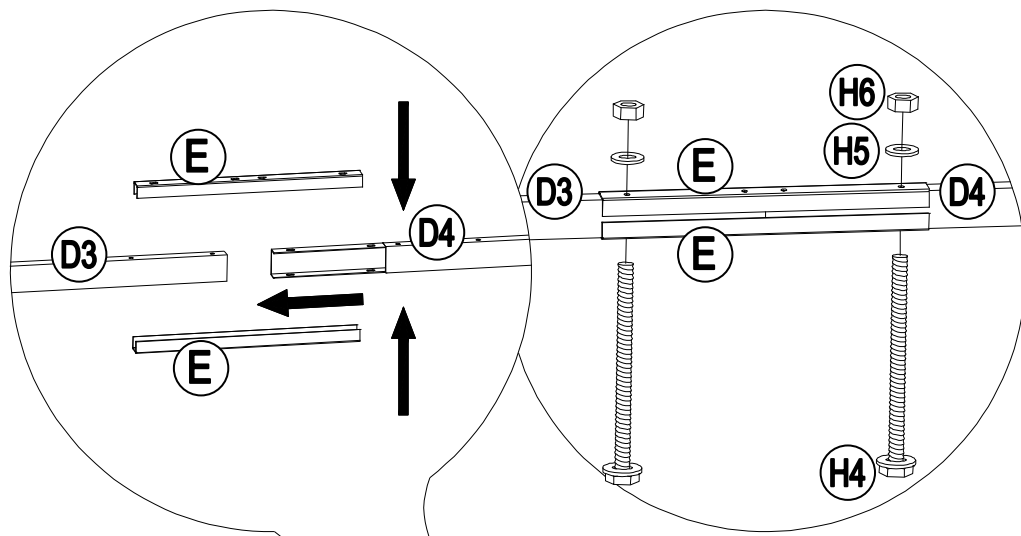
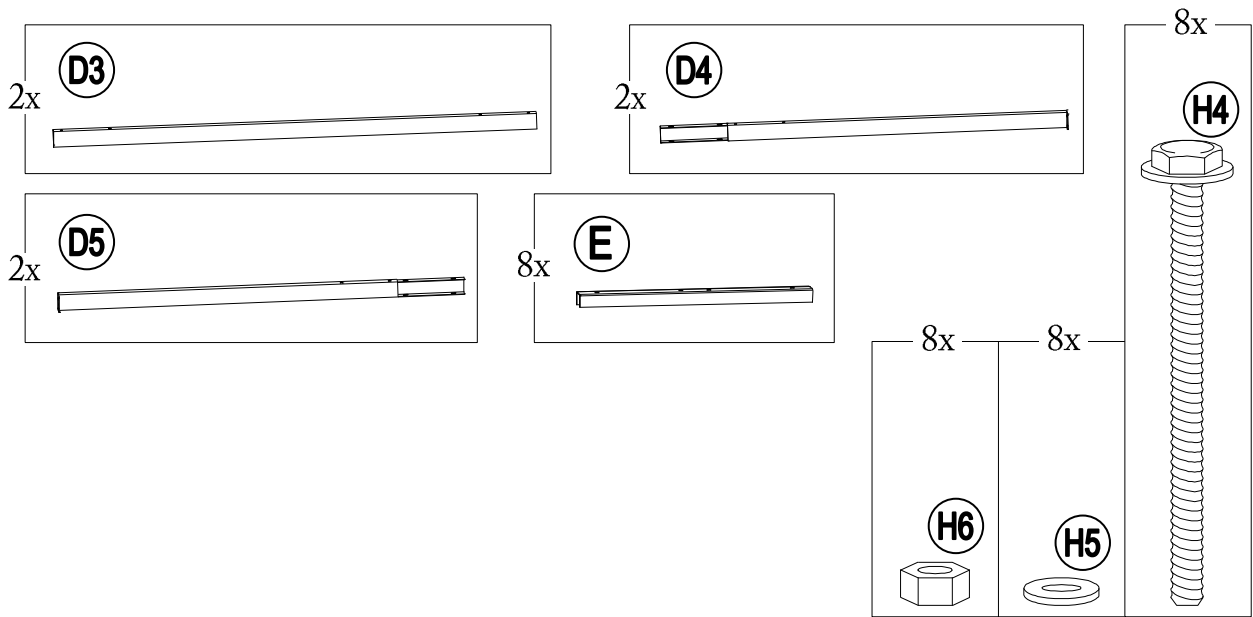

# 4

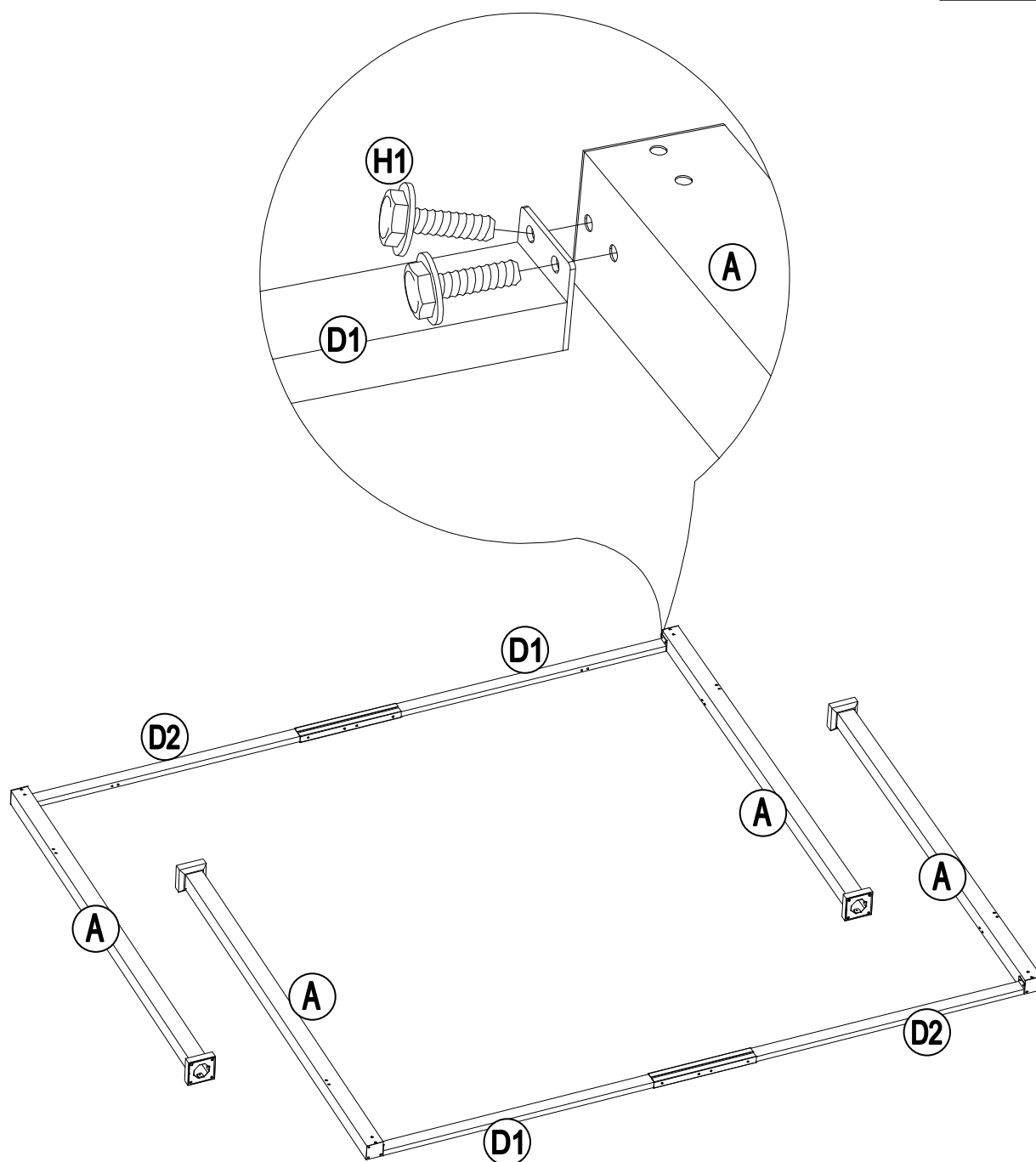
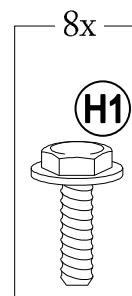

# 5

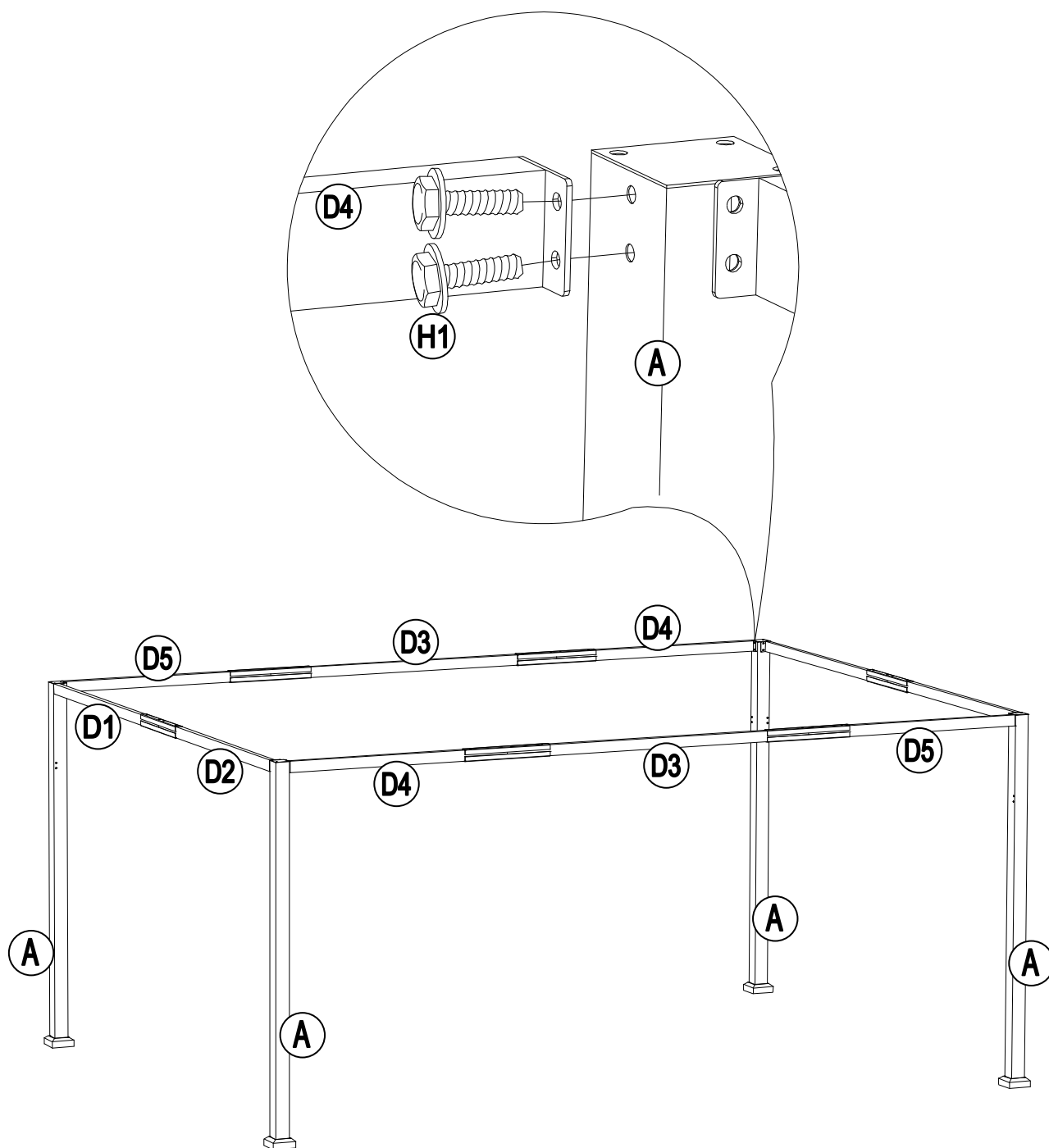
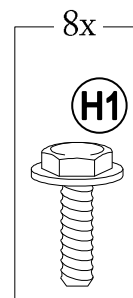

6

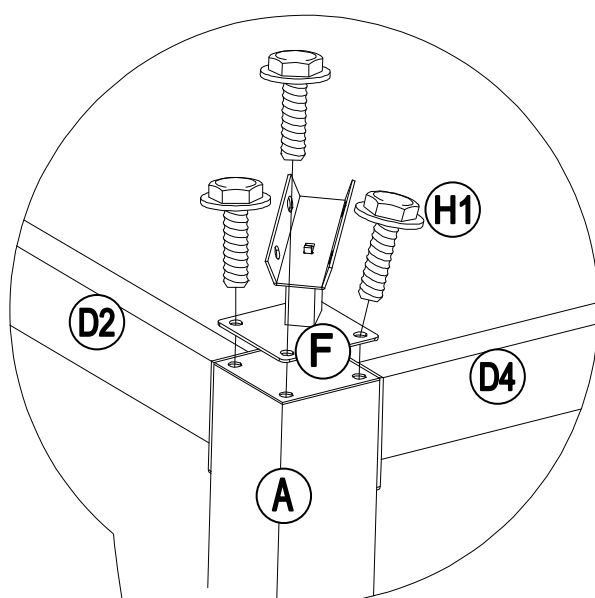
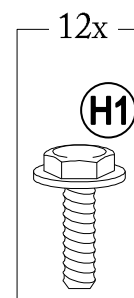
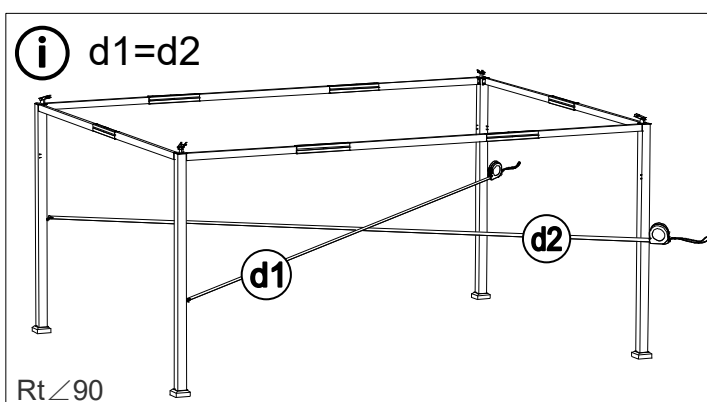
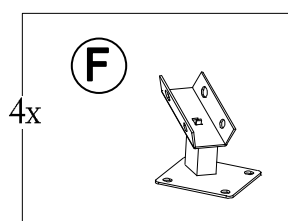

Please measure to make sure the length of d1 is equal to d2 before moving to next step to ensure a square frame and best results. Keep the beam at right angles to the post, the post at right angles to the ground, and keep the beam horizontal. /Avant de passer à l'étape suivante, veuillez prendre des mesures pour vous assurer que la longueur de d1 est égale à celle de d2 afin d'obtenir une armature carrée. Maintenez la traverse à l'horizontal en angle droit par rapport au montant et le montant en

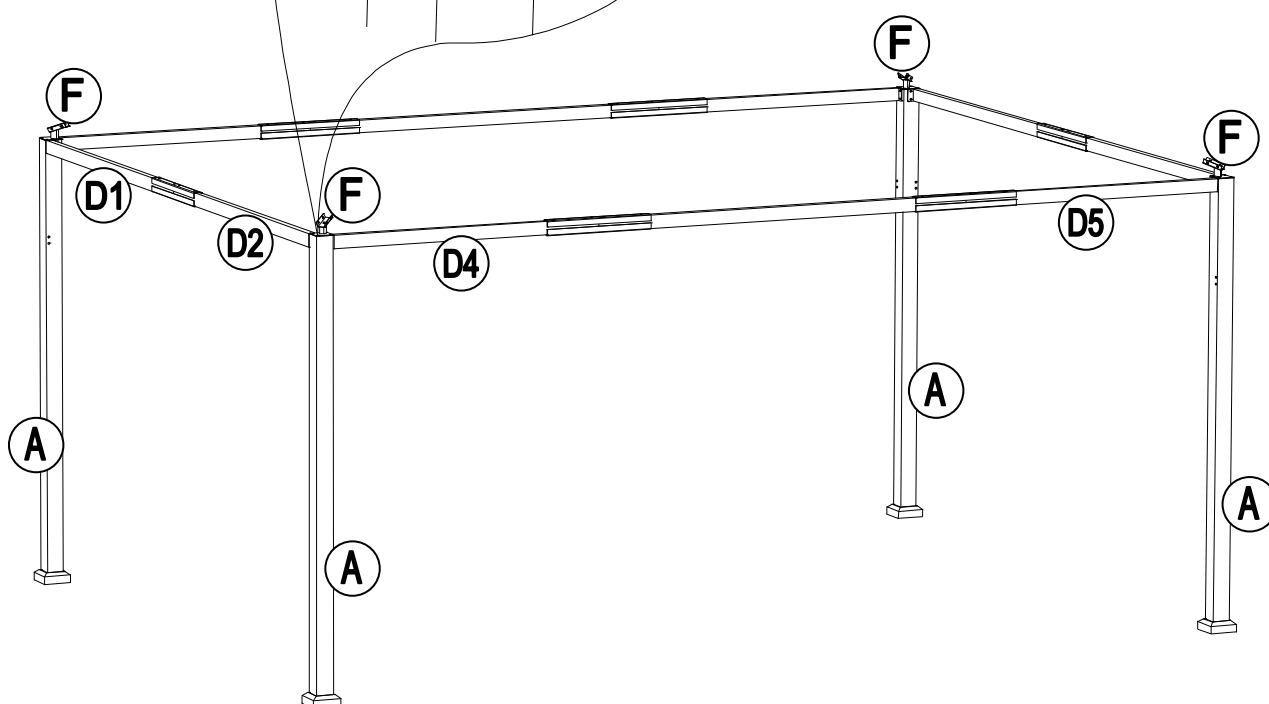



# 7

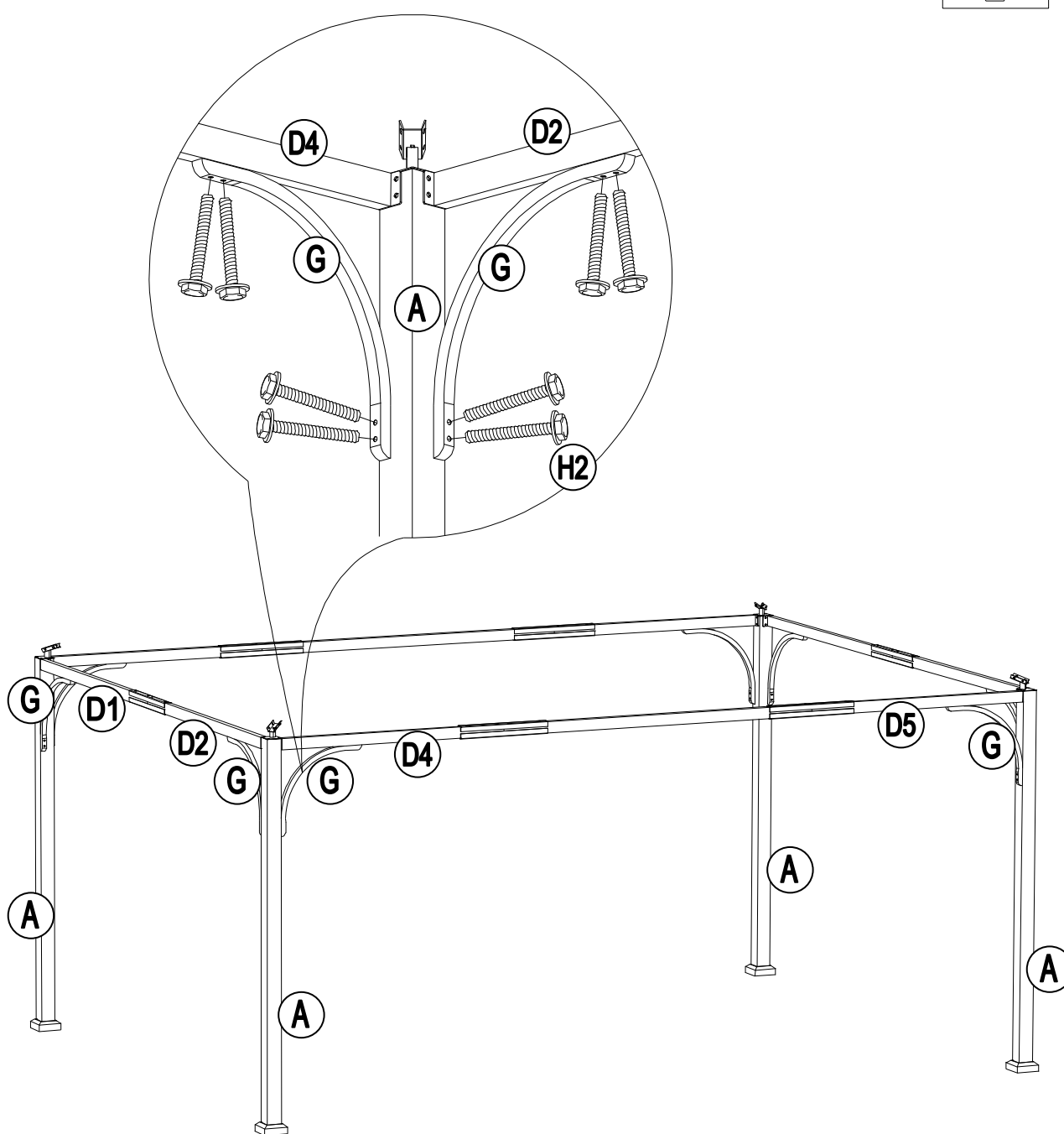
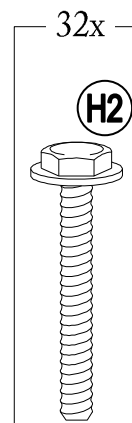
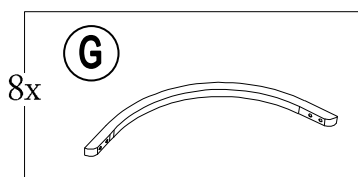

# 8

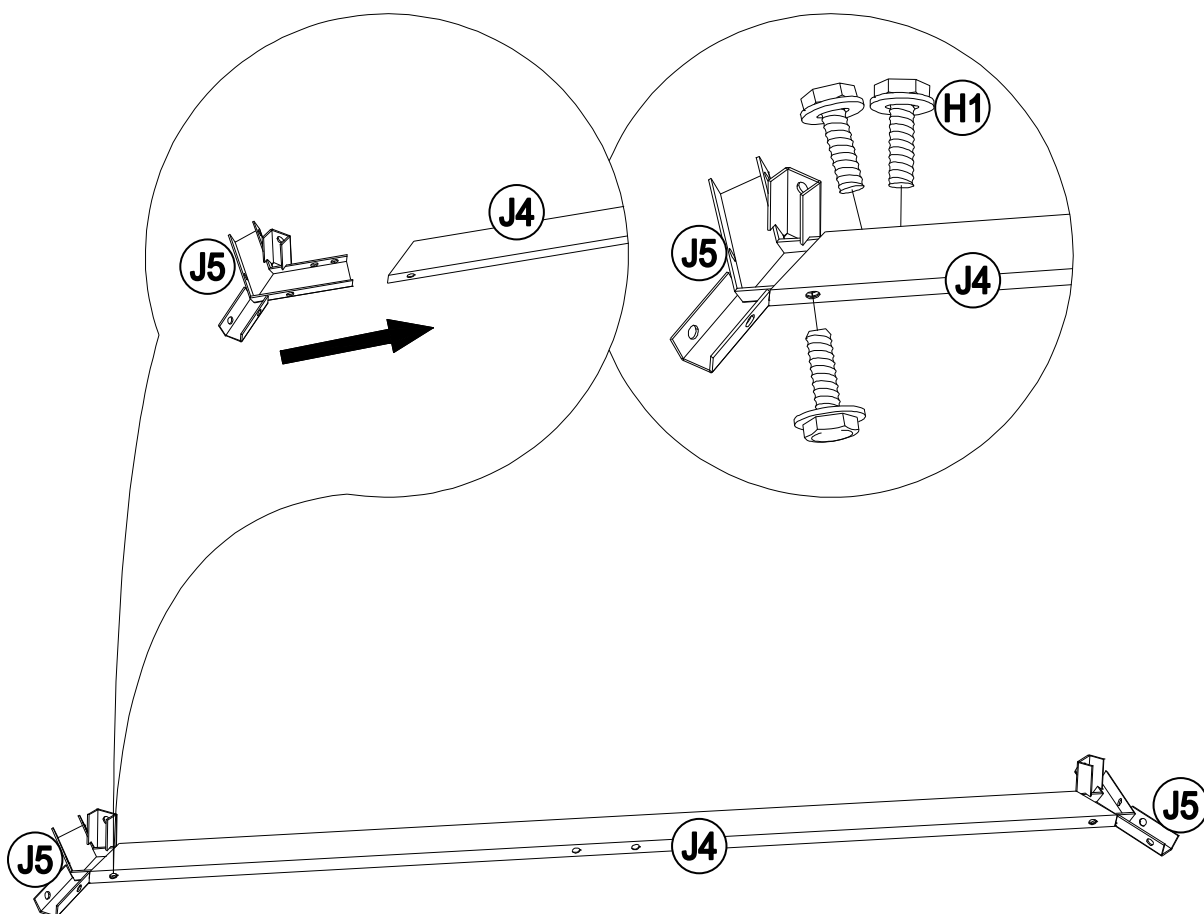
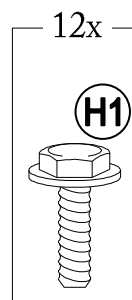
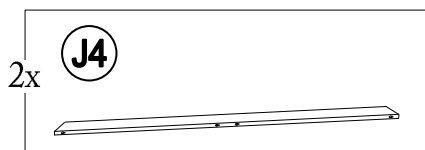
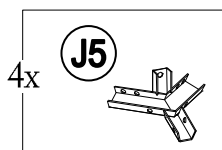

# 9

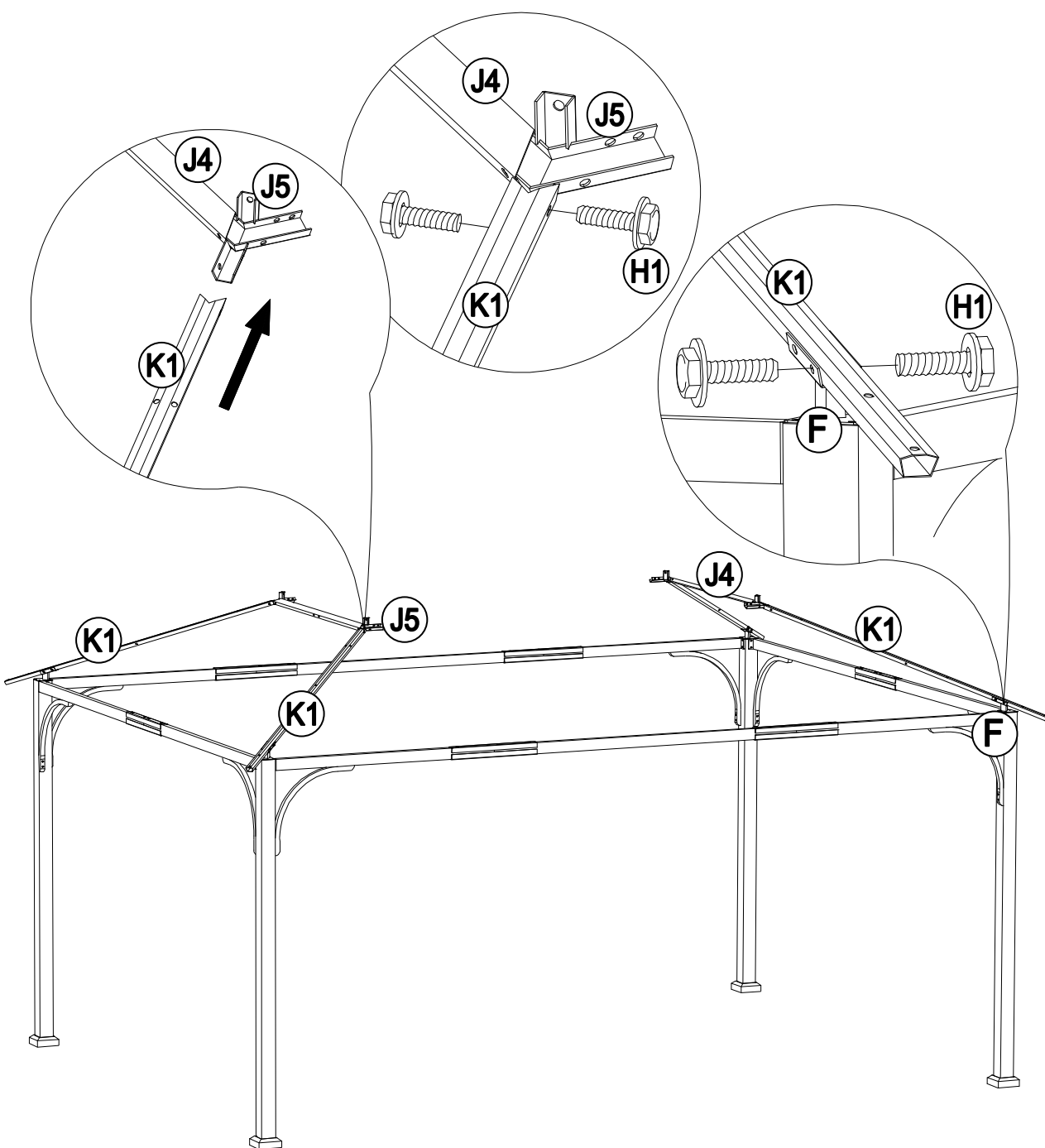
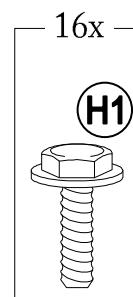
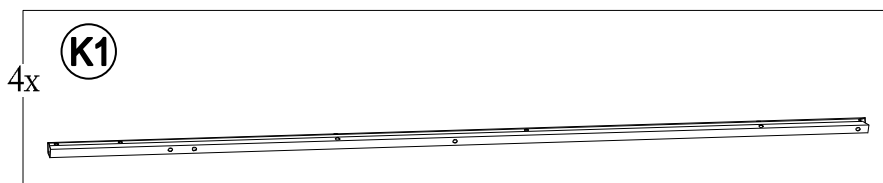

# 10

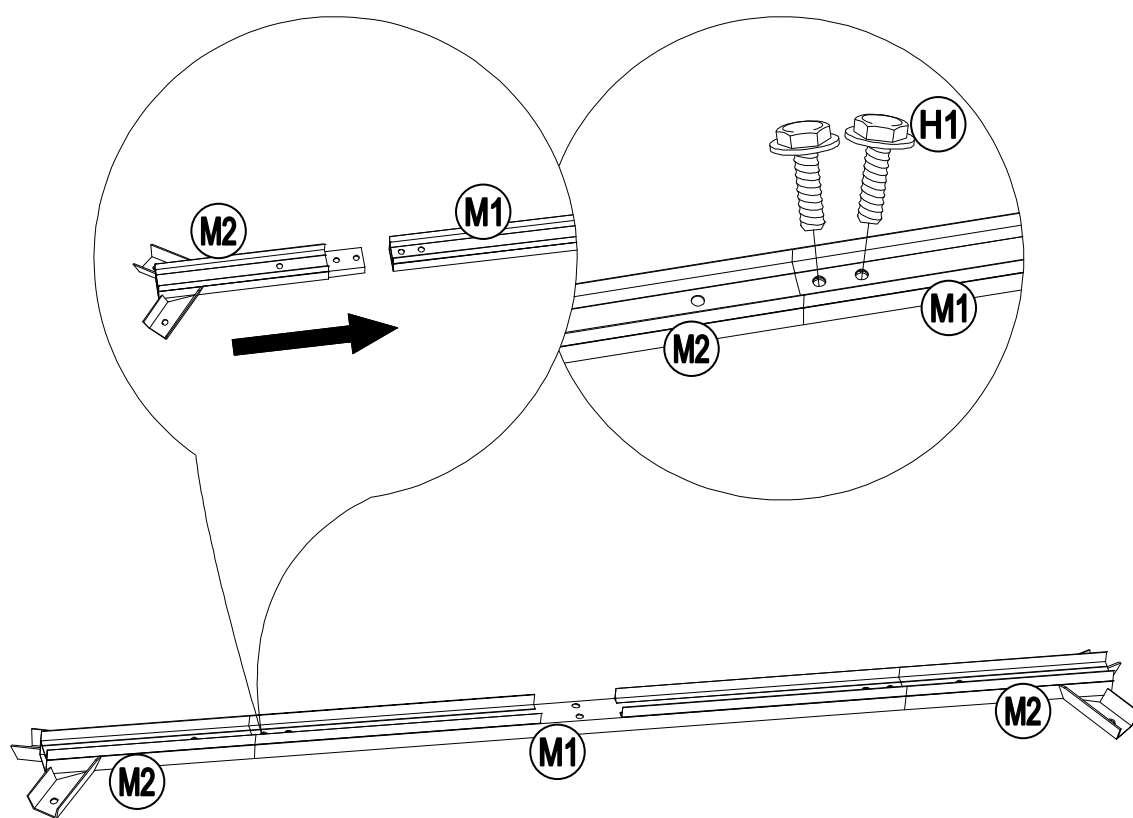
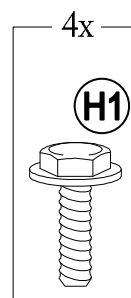
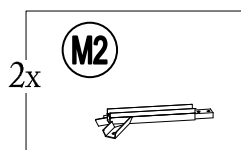
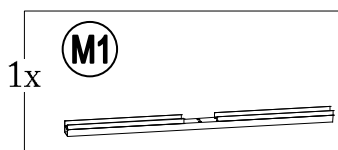

# 11

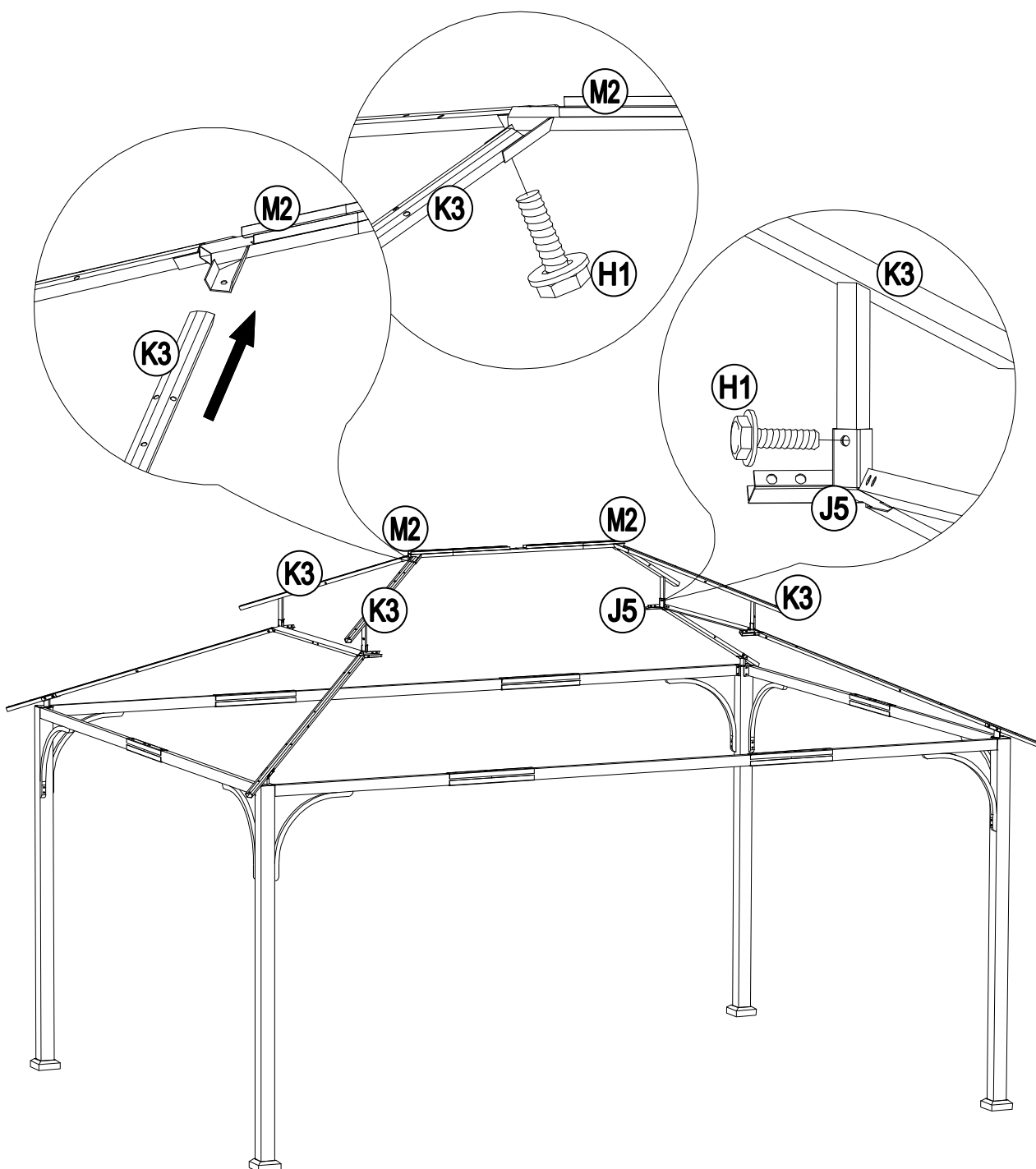
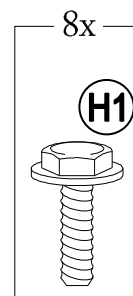
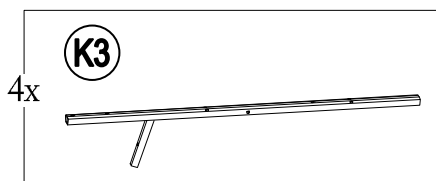

# 12

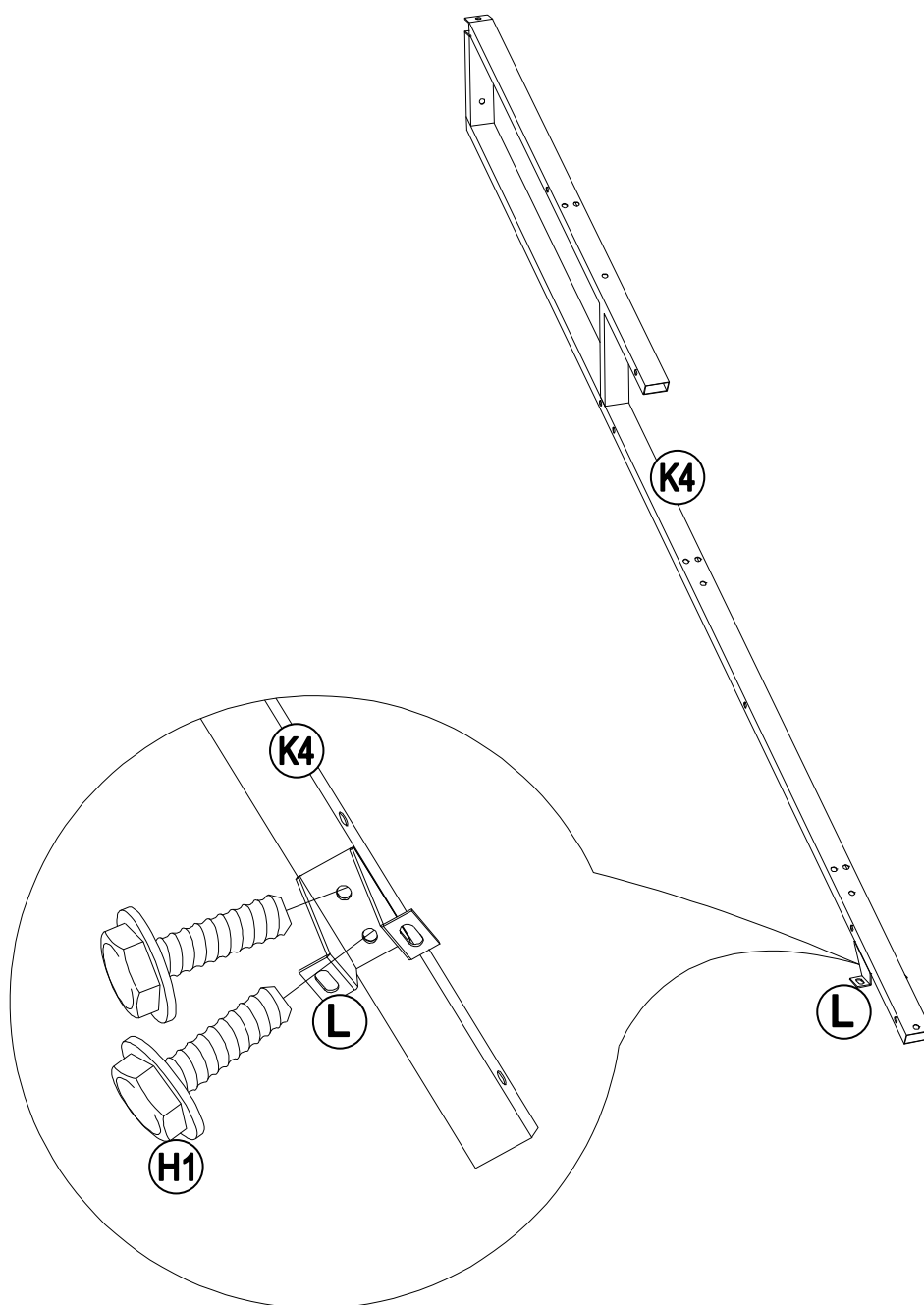
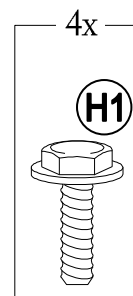
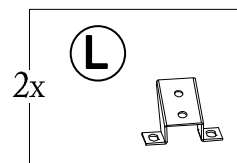
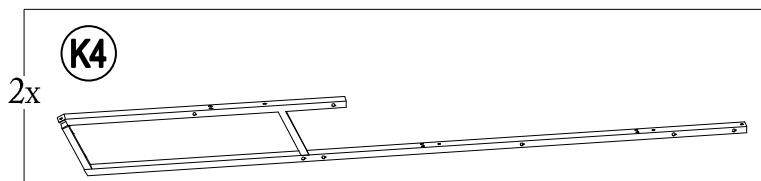

# 13

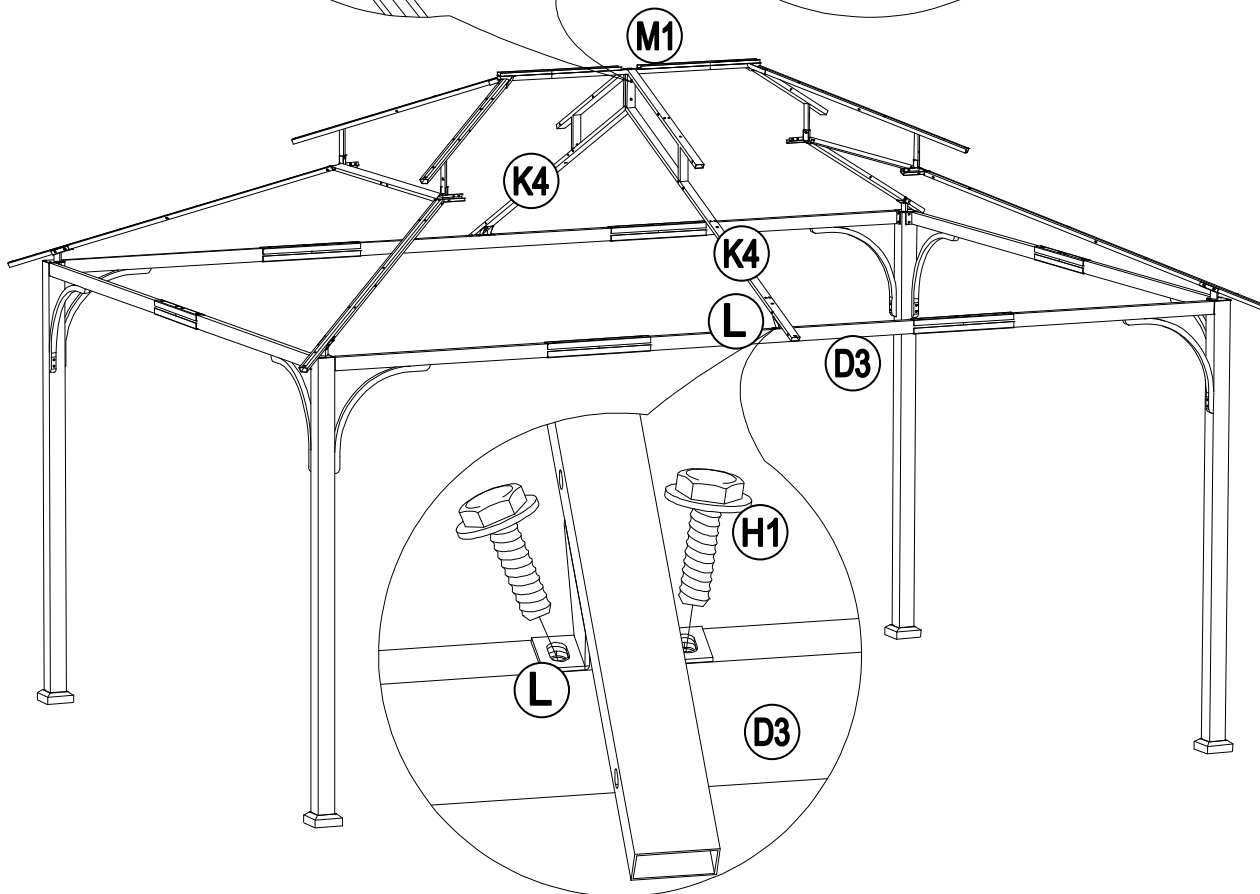
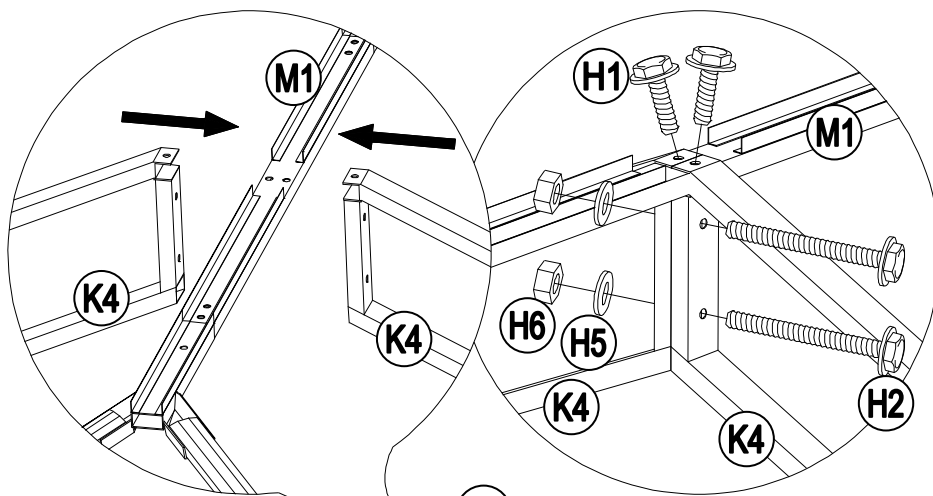
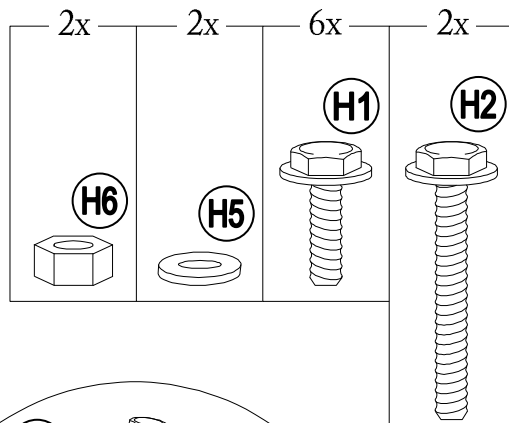

# 14

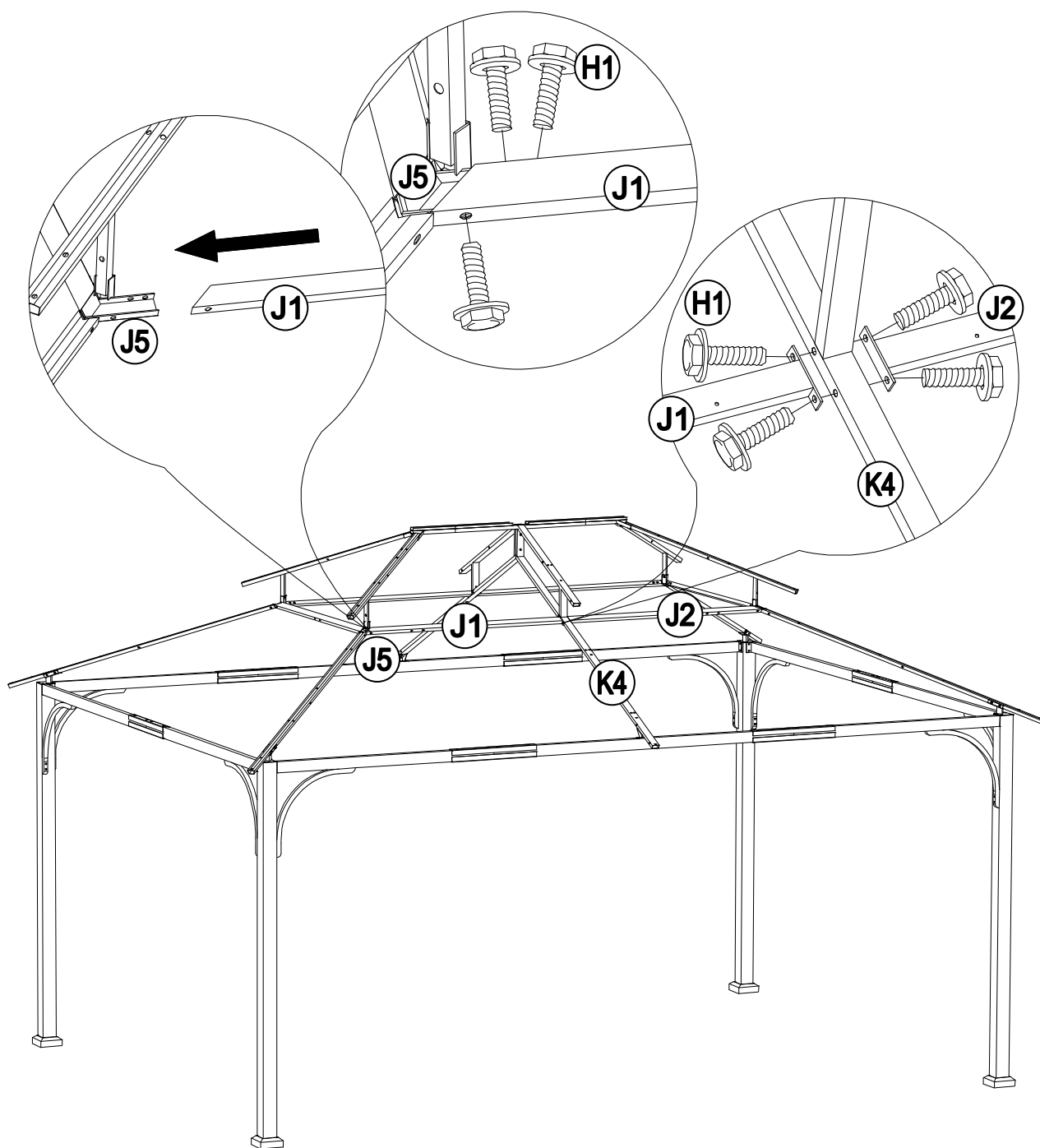
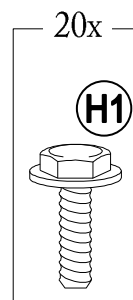
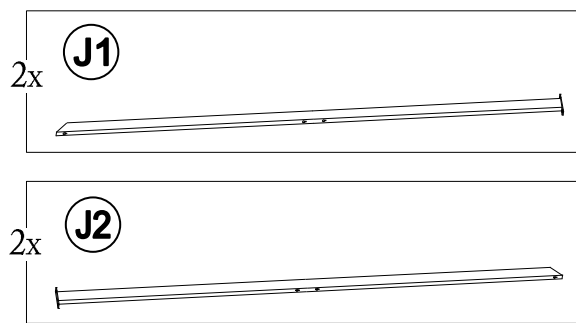



# 15

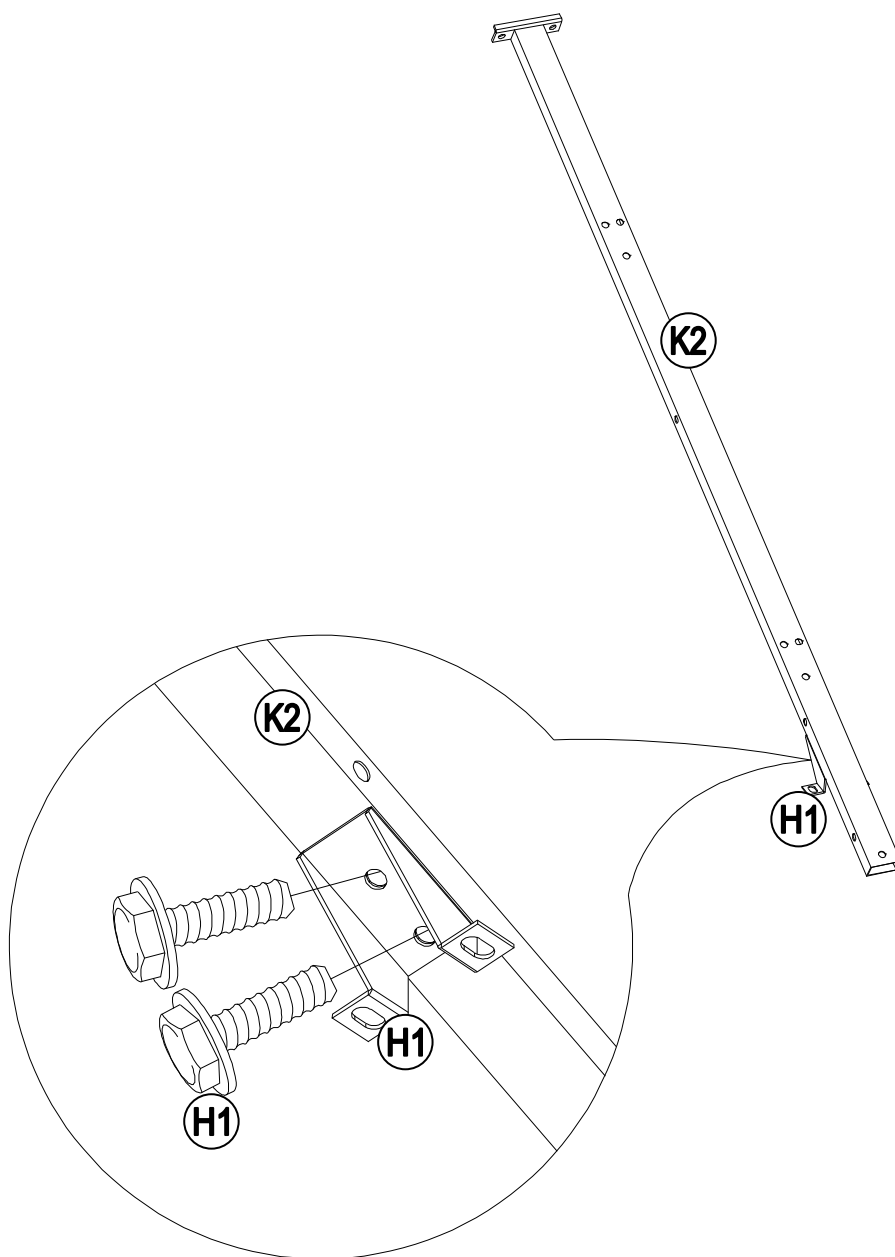
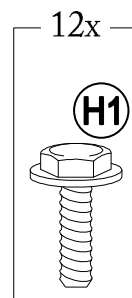
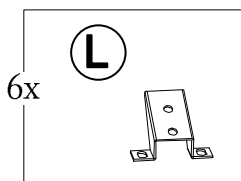
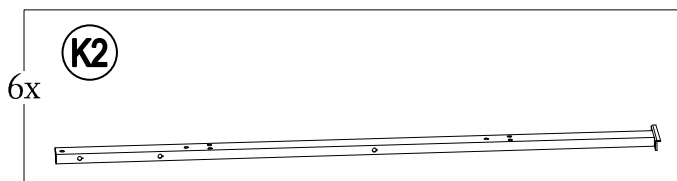

# 16

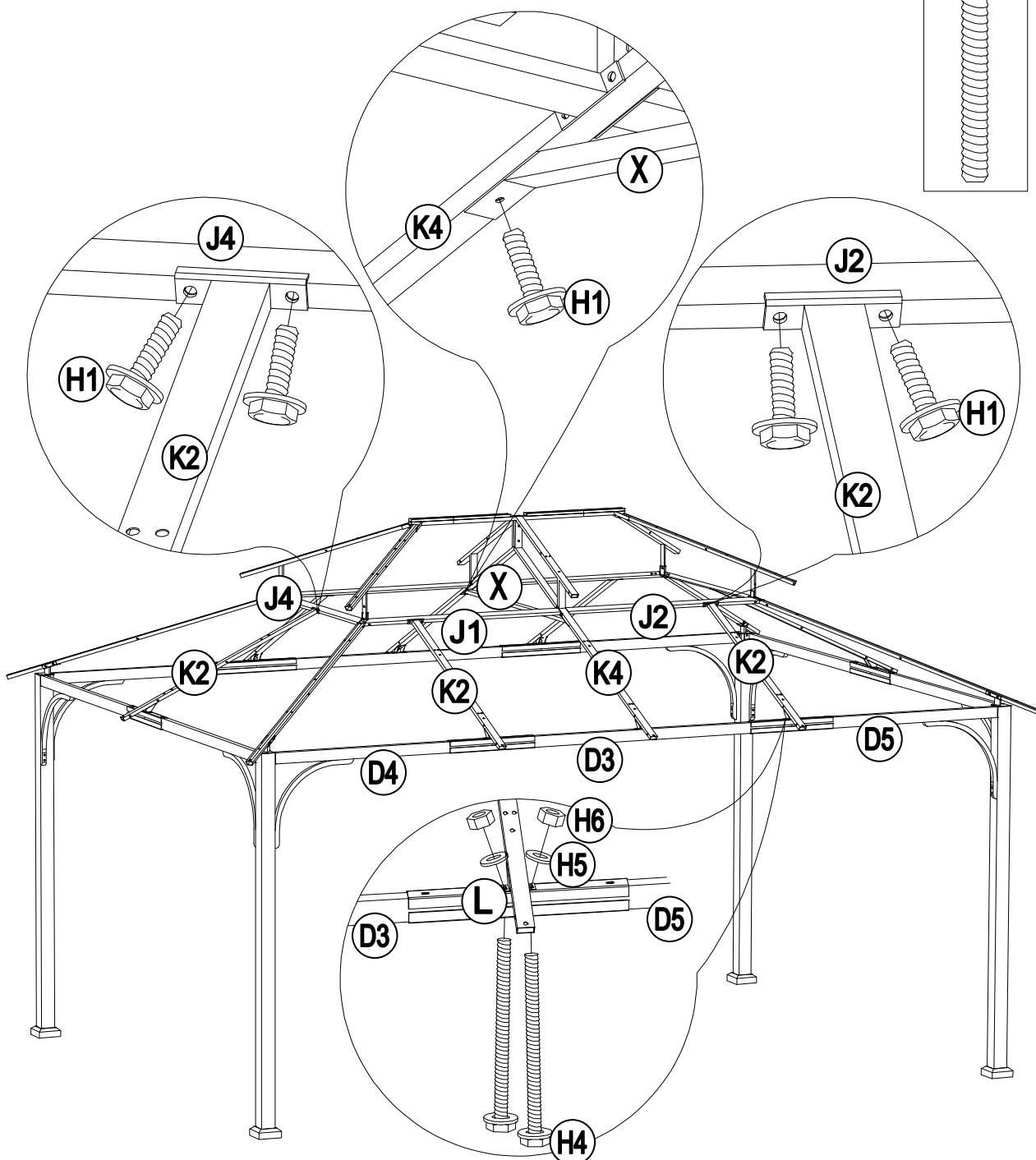
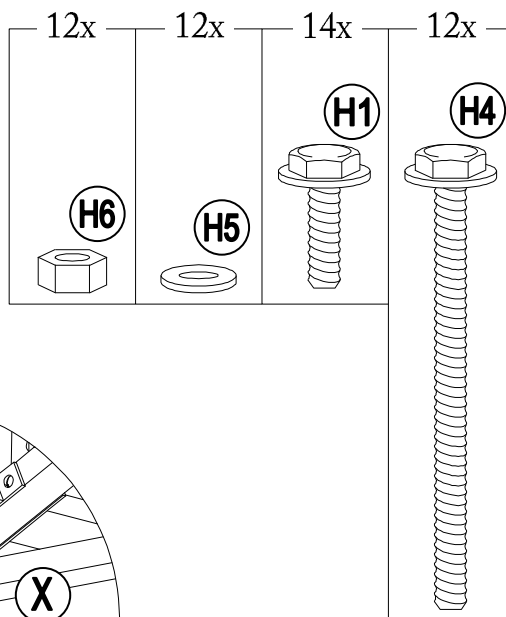
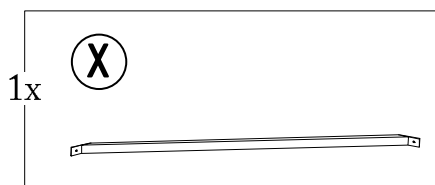

# 17

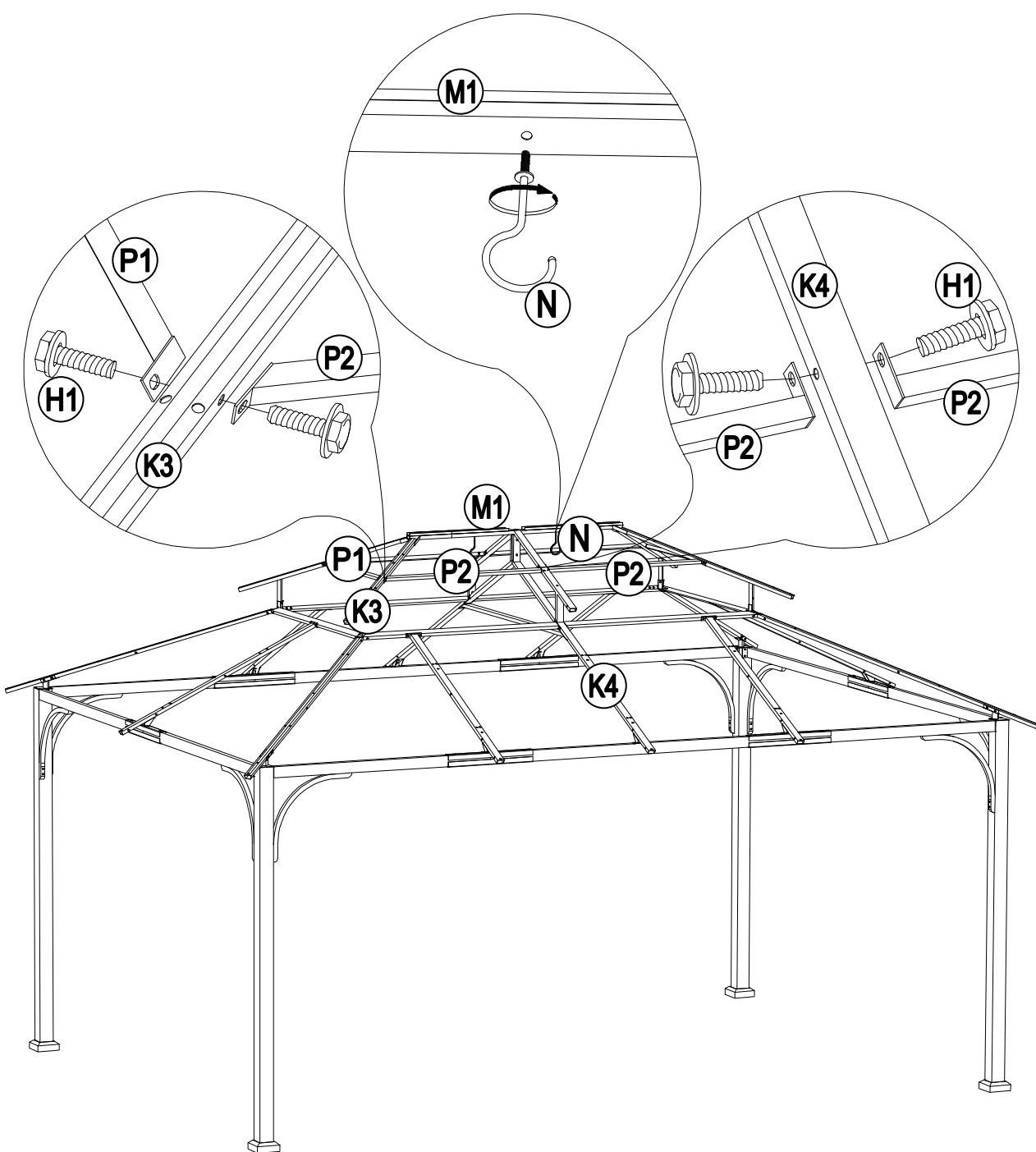
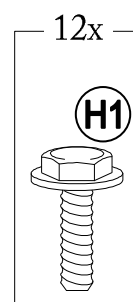
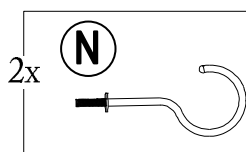
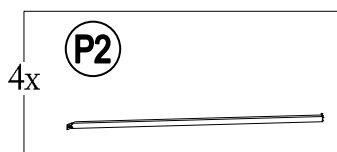
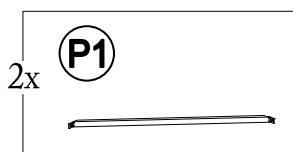

# 18

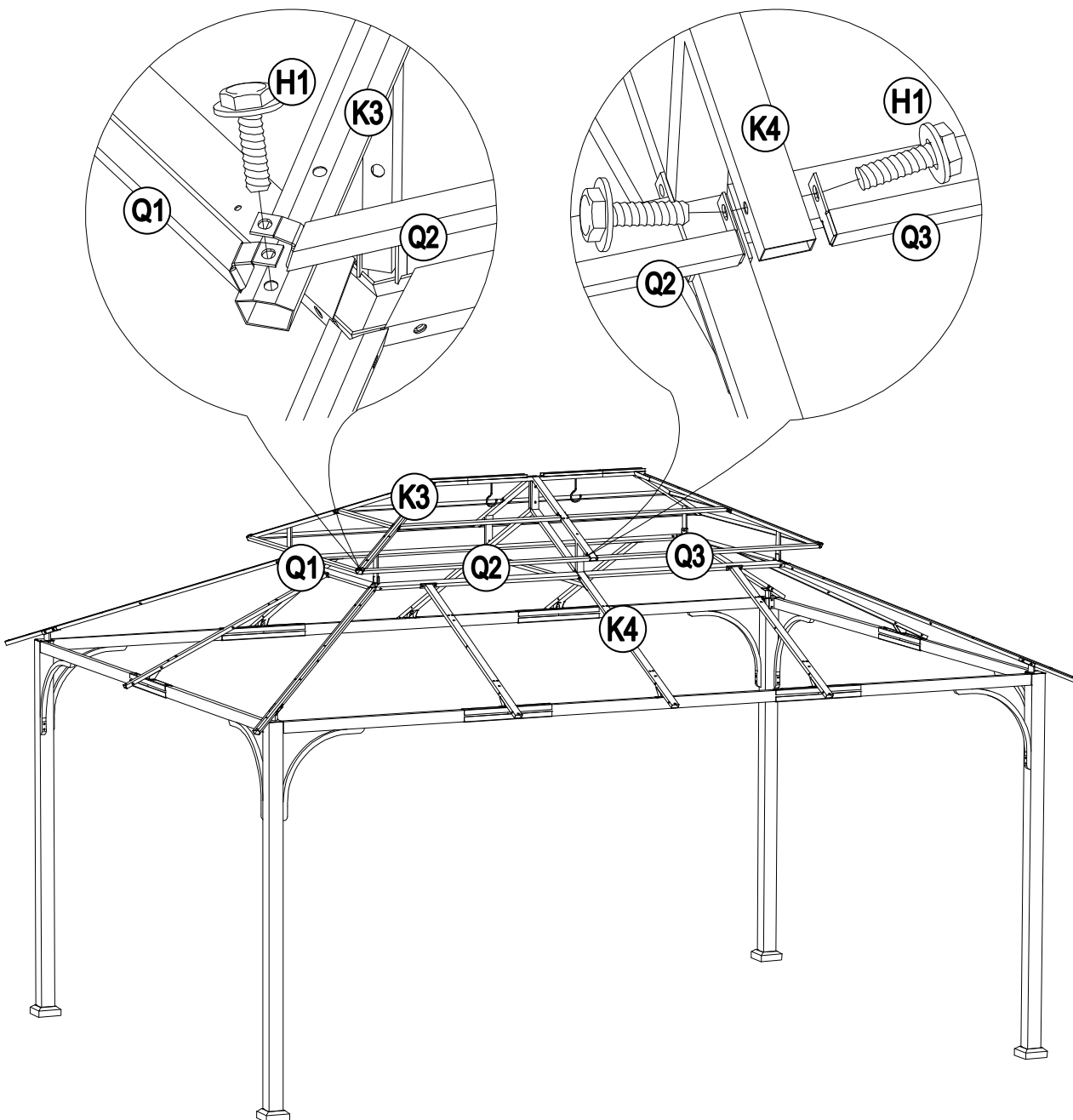
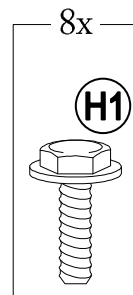
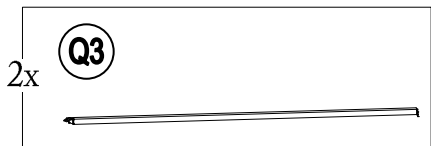
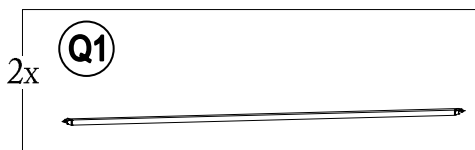

# 19

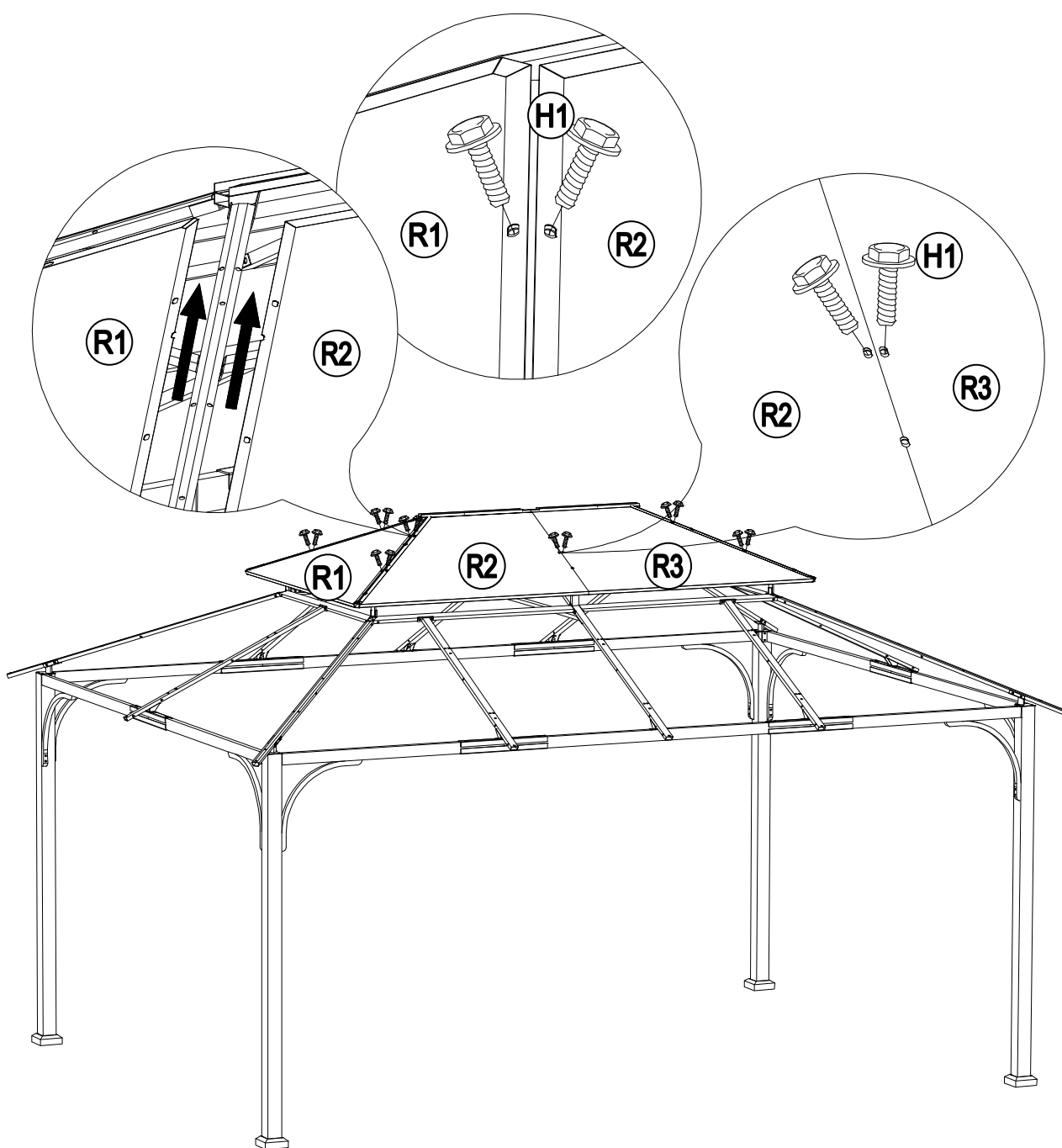
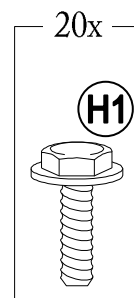
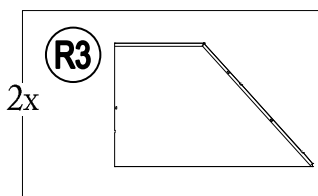
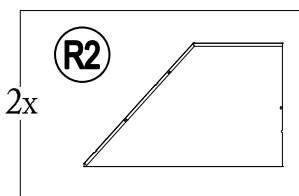
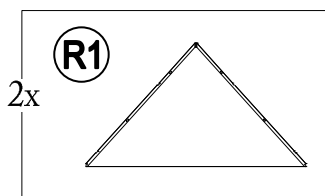

# 20

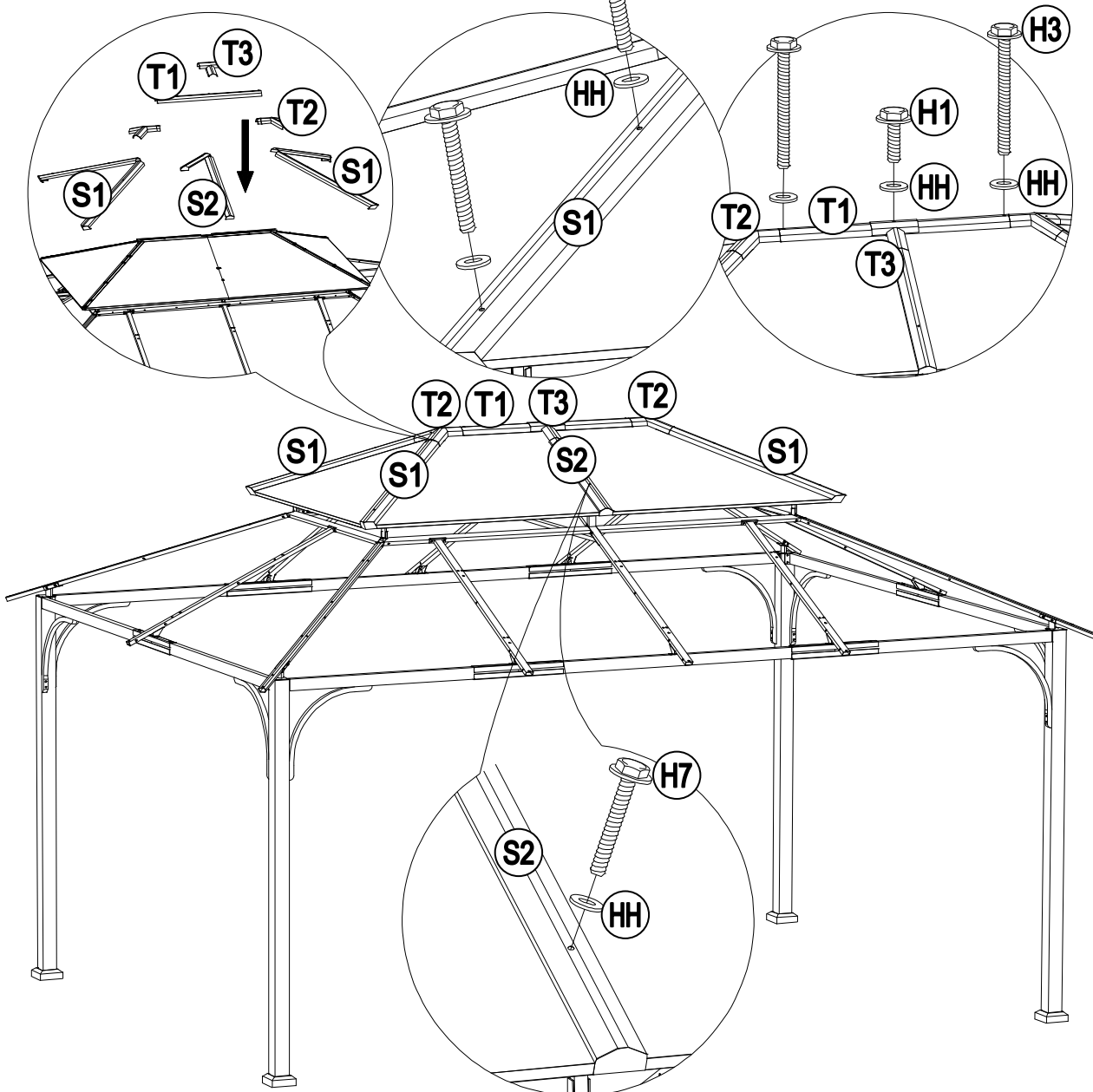
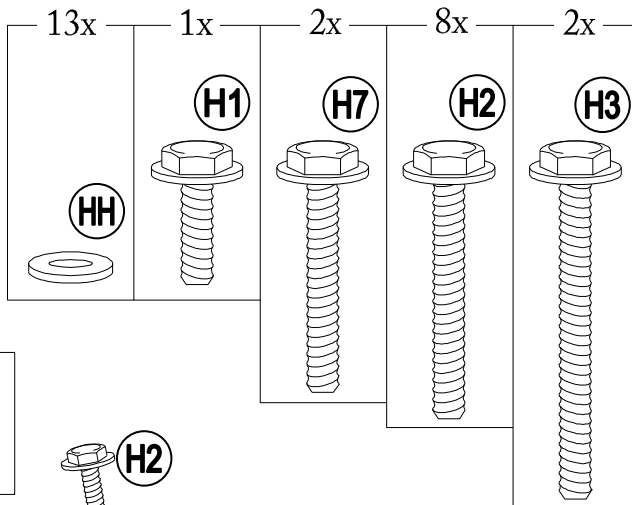
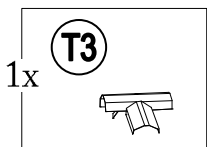
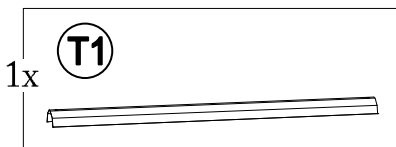
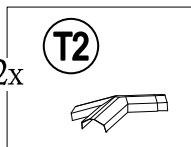
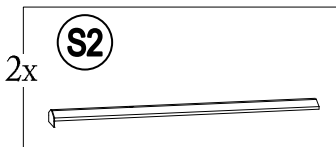
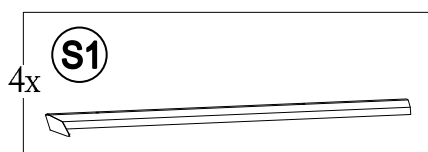

# 21

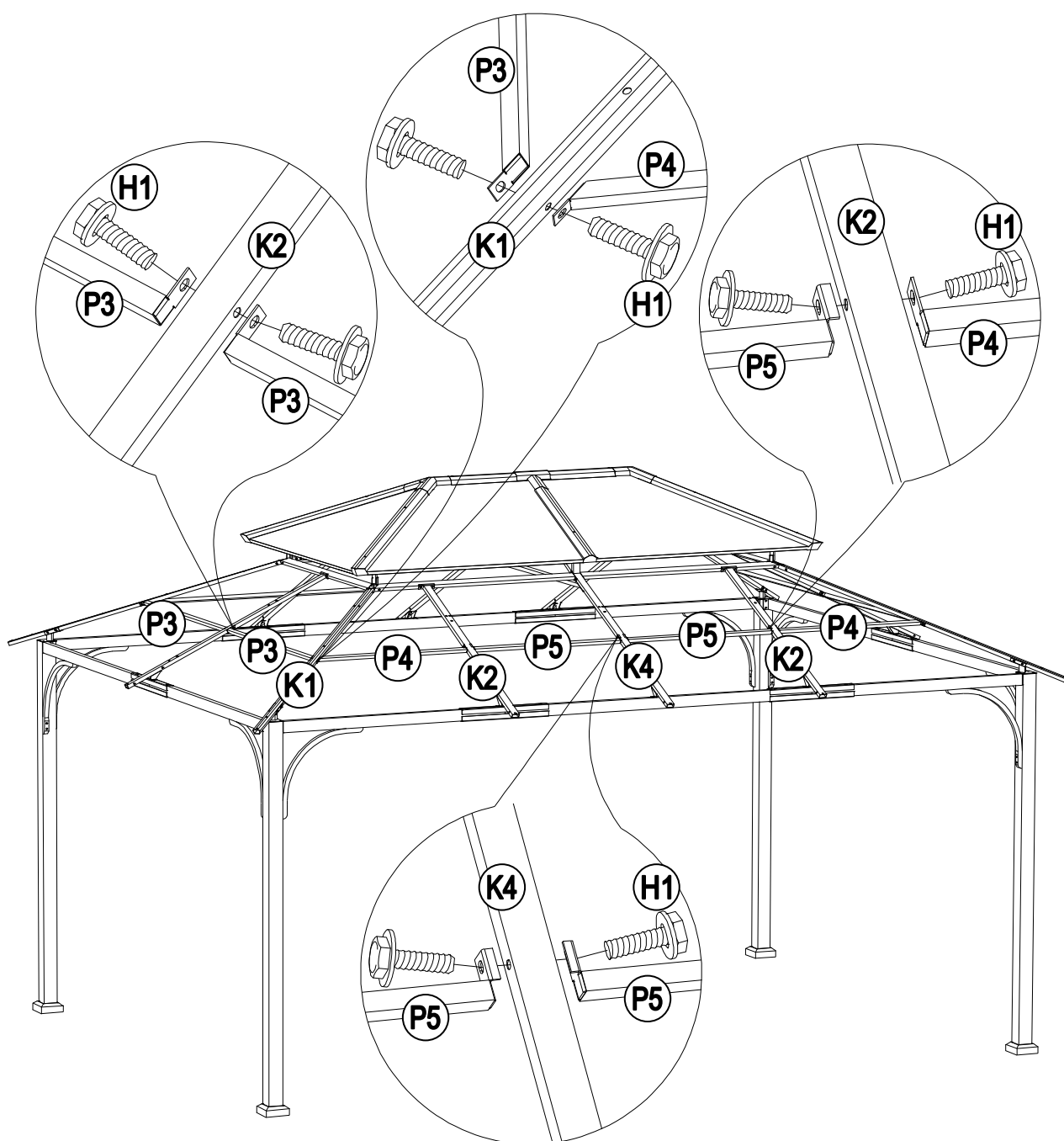
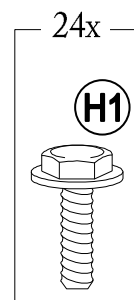
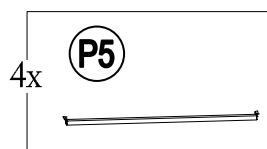
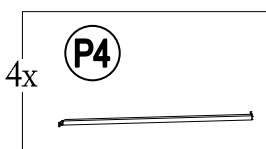
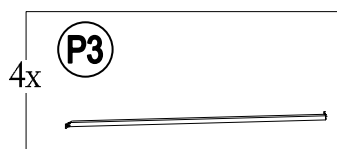

# 22

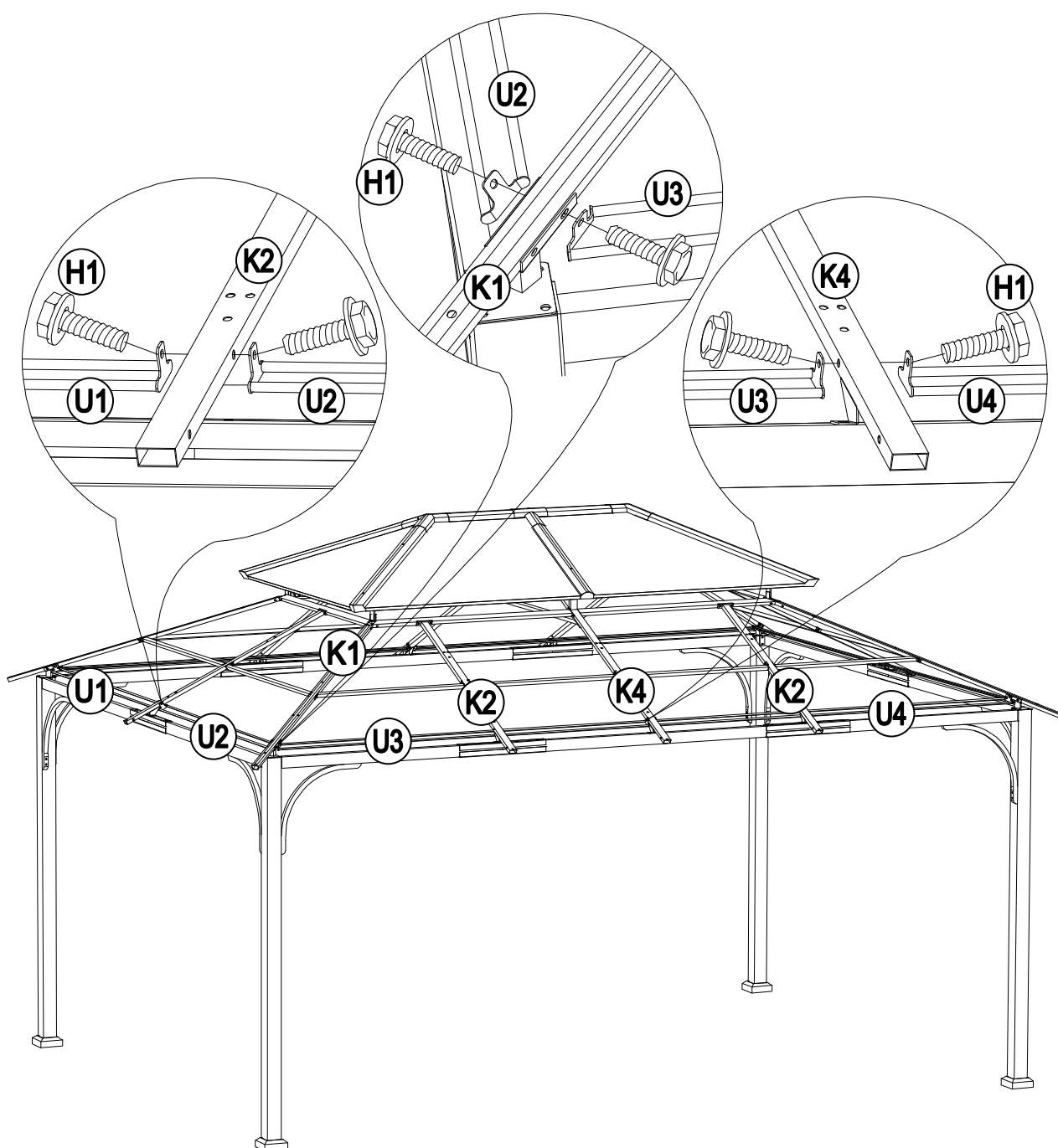
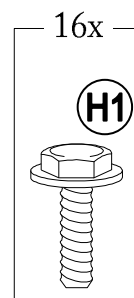
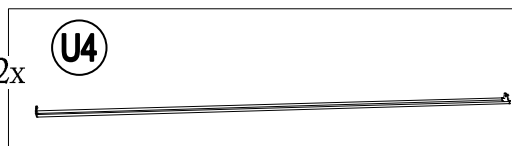
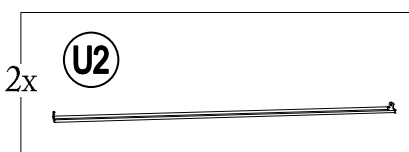
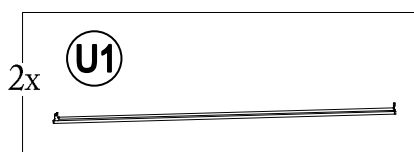



# 23

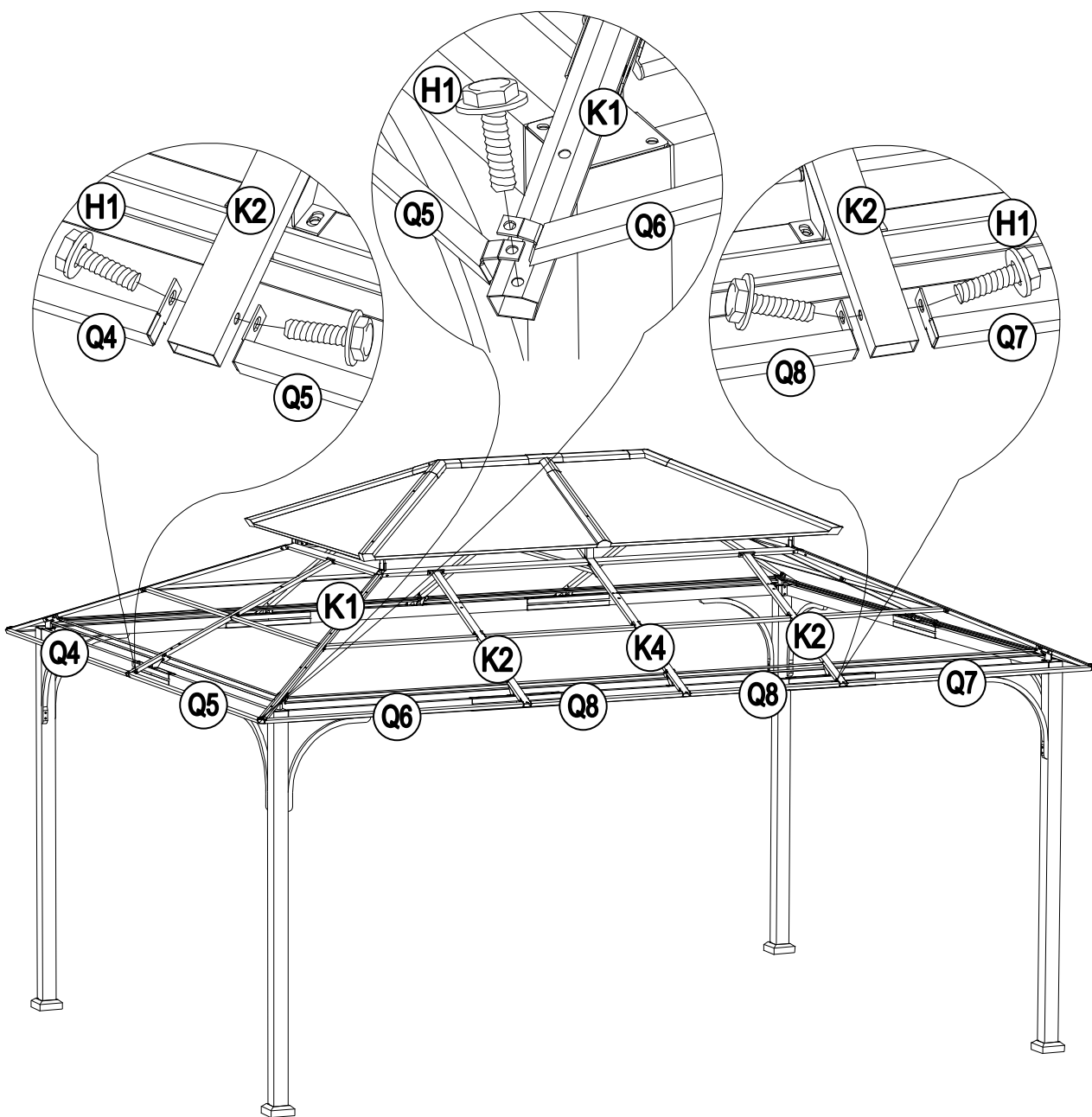
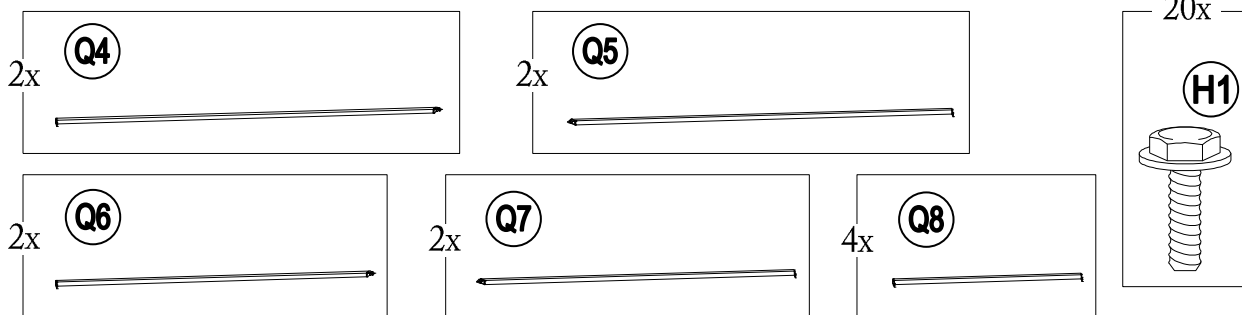

# 24

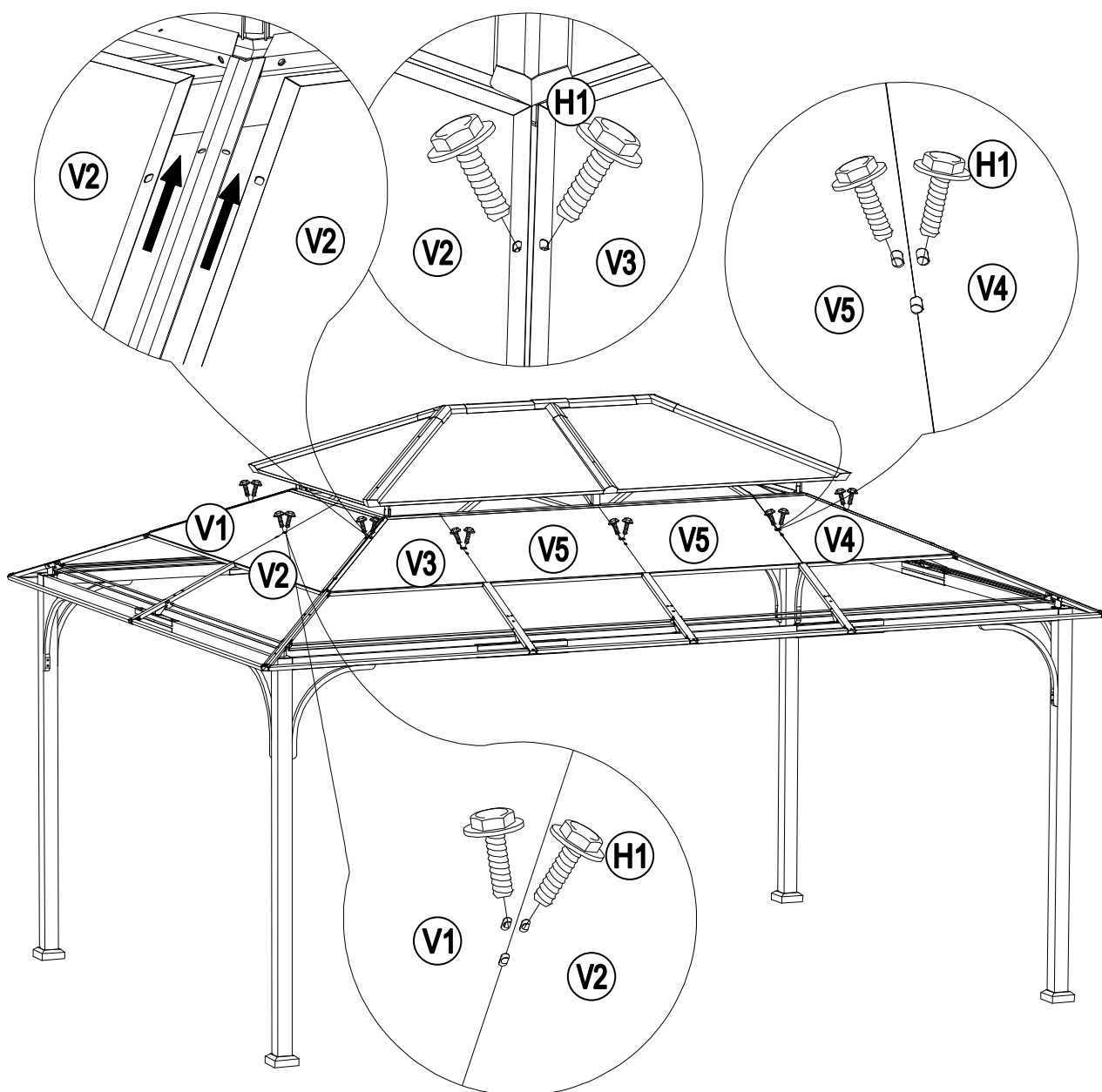
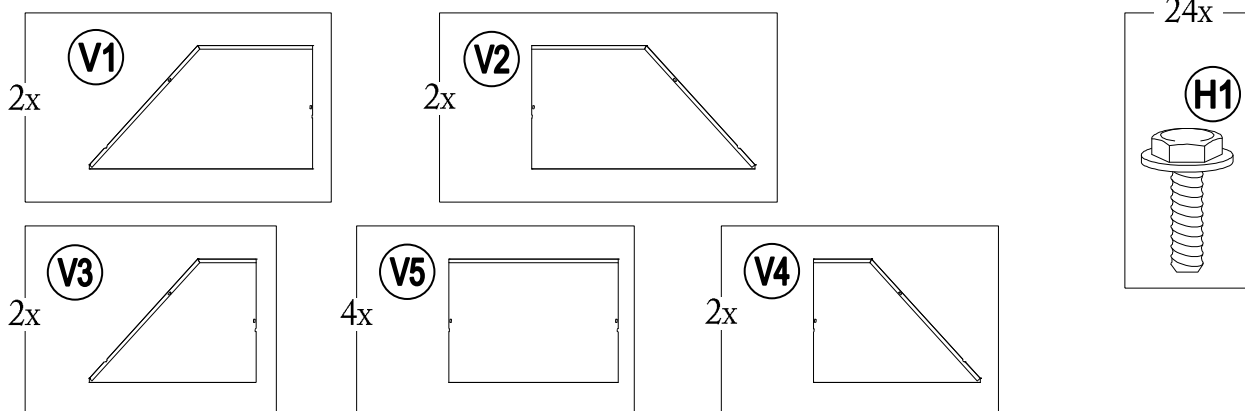

# 25

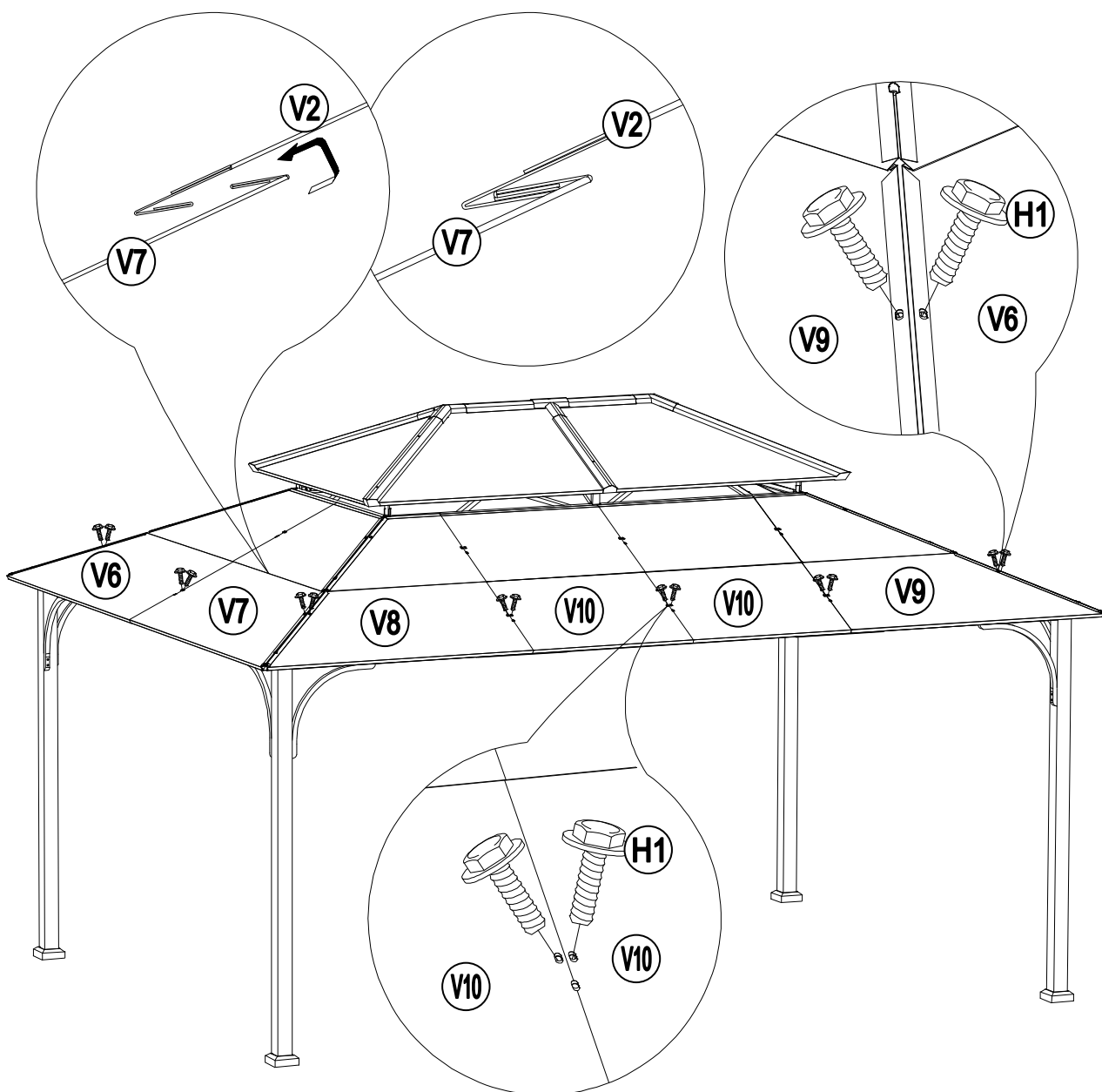
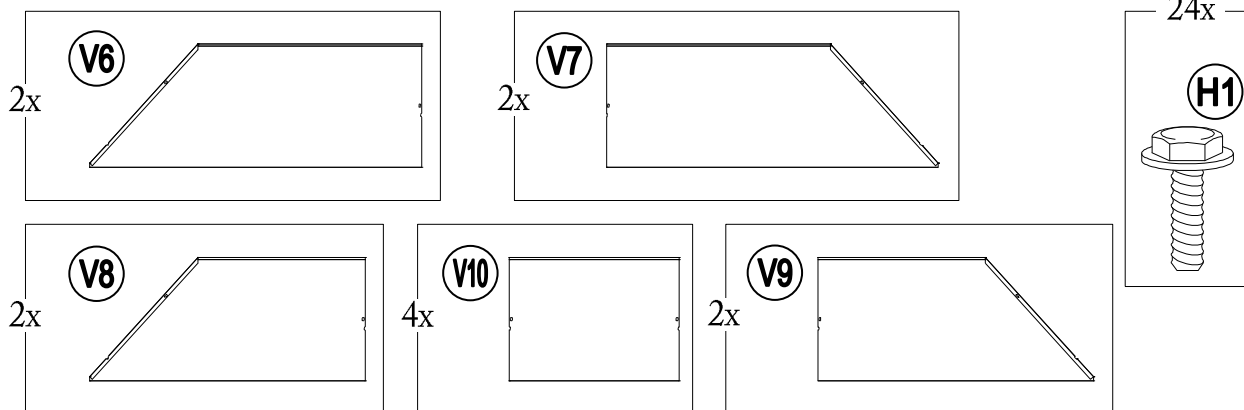

# 26

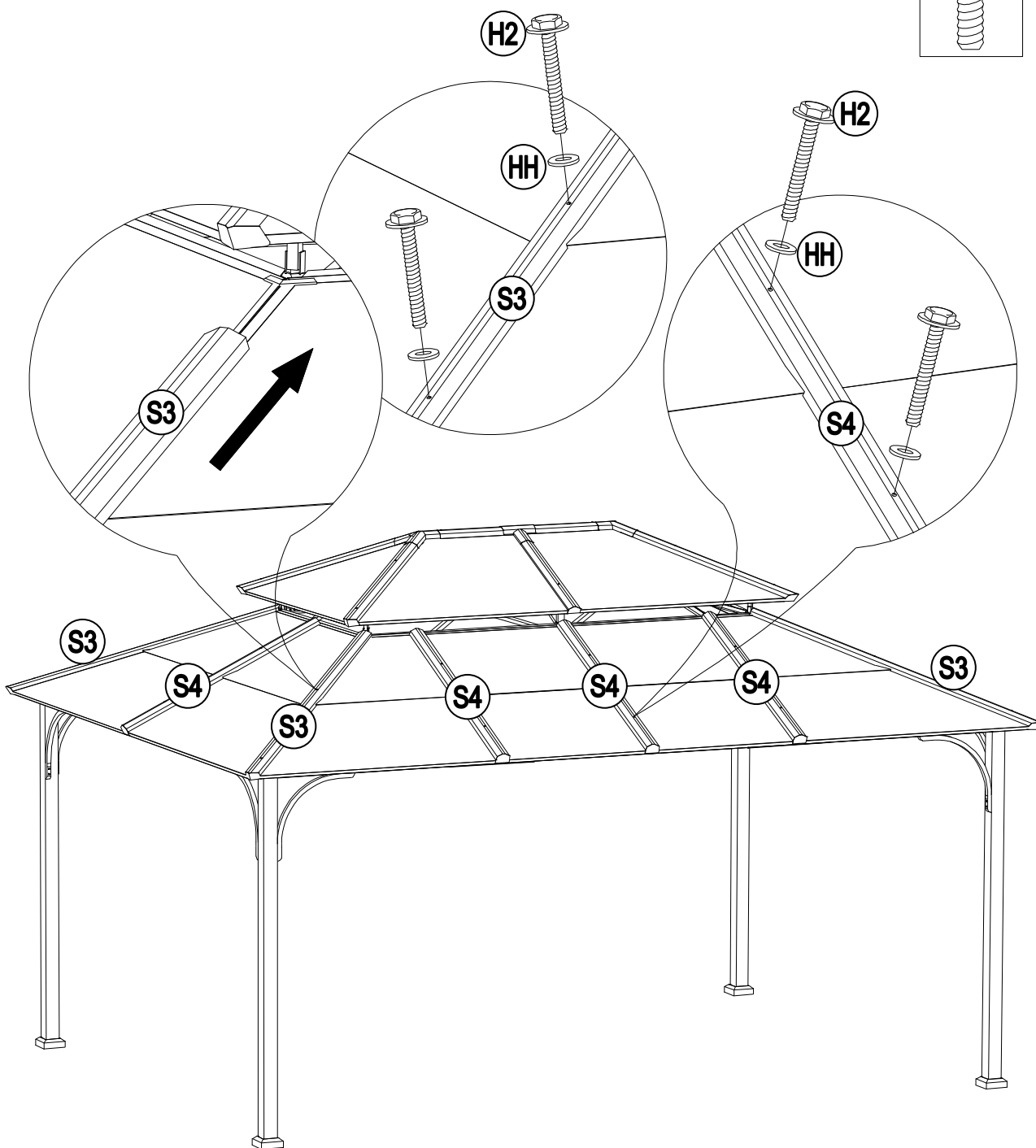
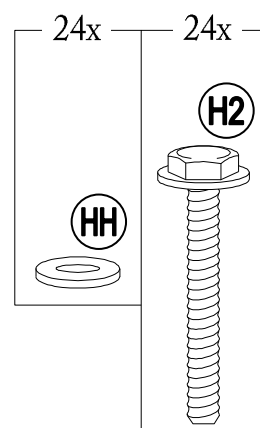
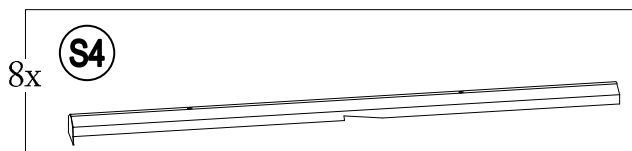
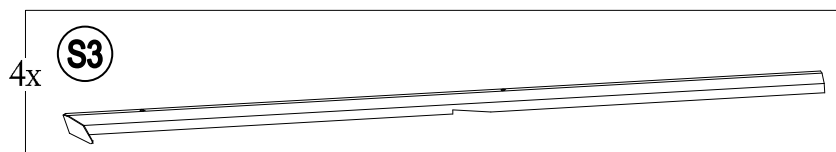

# 27

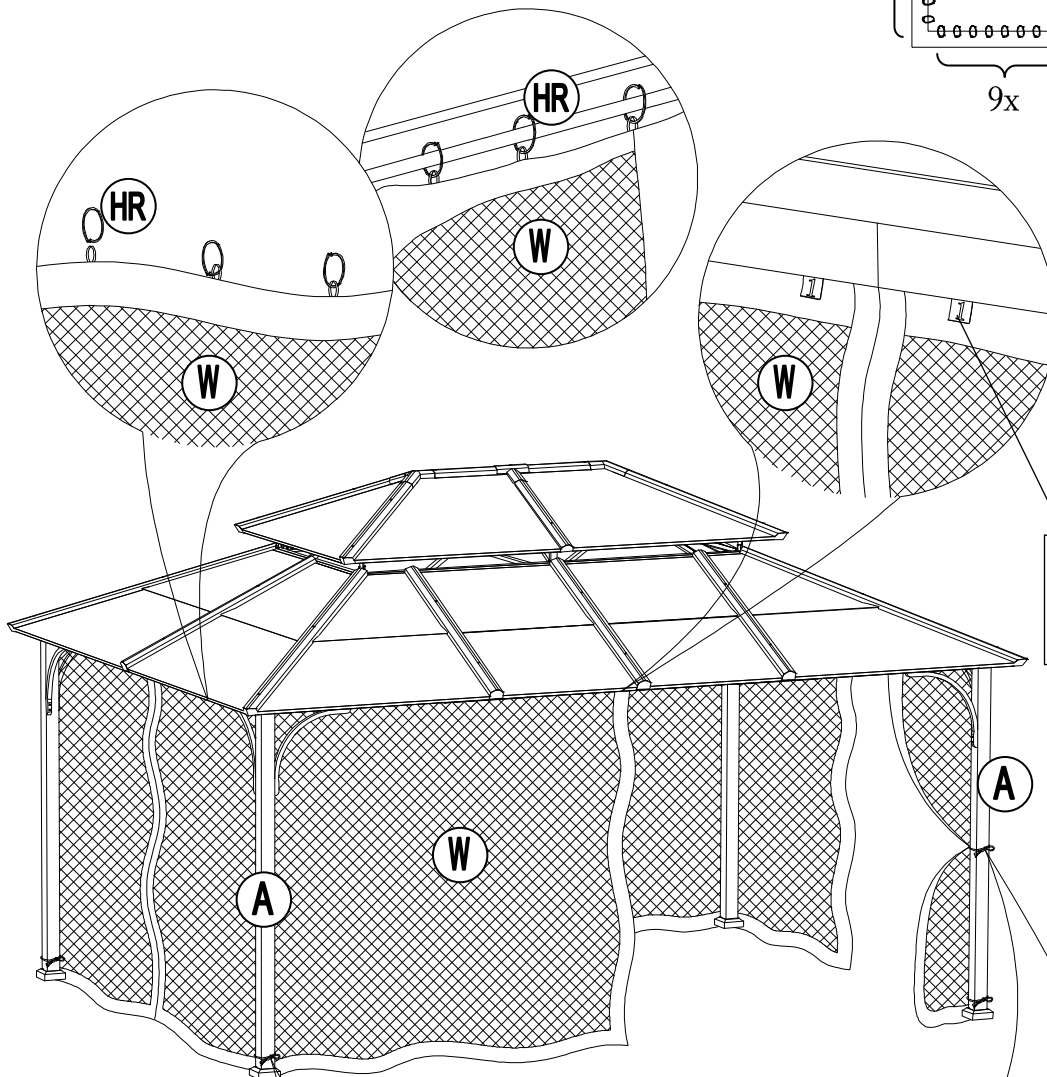
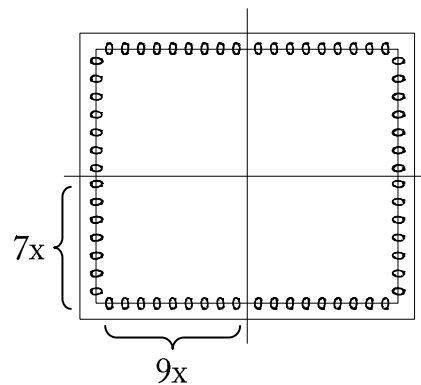
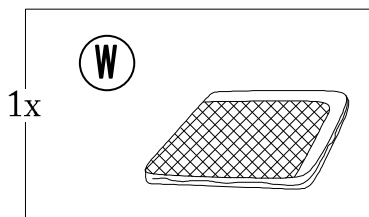

Please do the matching of zippers for different panels as showing the picture

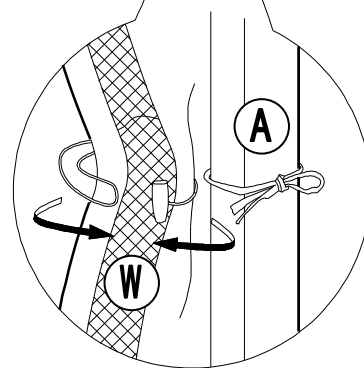
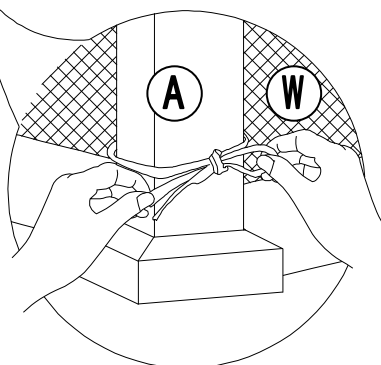

# 28

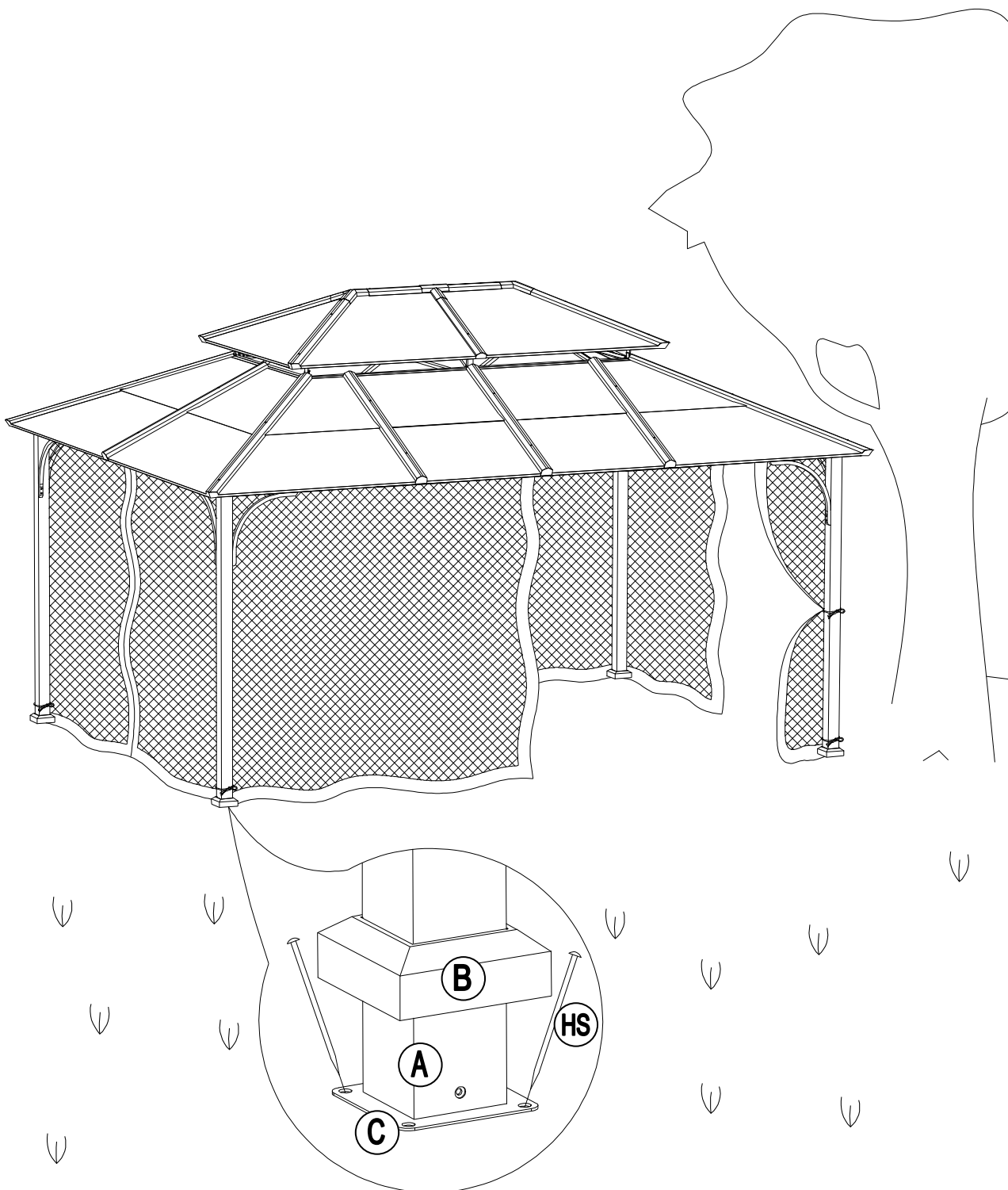
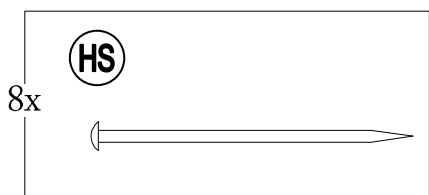

## Maintenance

- Steel components for this gazebo are treated with rust inhibiting paint . However, due to the nature of steel, surface oxidation (rusting) will occur if these protective coatings are scratched. This is not a defect and thus not covered by the warranty.
- To minimize this condition, it is recommended to use care when assembling and handling the product to prevent scratching the paint. Should any scratching or damage occur, it is recommended to cover the scratch immediately with rust inhibiting resistant paint (not included).
- Surface rust can also be easily removed with a very light application of regular cooking oil or WD-40. If surface oxidation (rusting) occurs and if no measure is taken to prevent this, the oxidation may start dripping onto deck or patio and caused damaging stains, which may be difficult to remove. This can be prevented if the above-mentioned measures are taken to keep the product from oxidizing.
- Do not use bleach, acid, or other abrasive cleaners on the roof or frame parts.
- Keep instruction manual for future reference.
- Keep the original packaging to store the gazebo.
- Periodically check and ensure that all bolts are well-tighten during use.

## Limited Manufacturer's Warranty

Sunjoy Group warrants to the original purchaser that this item is free from defects in workmanship and materials for a period of 1 year from the date of purchase, provided the item was factory-sealed at the time of purchase and is maintained with care and used only for personal, residential purposes. Should any manufacturing defect arise within this warranty period, Sunjoy Group will replace (at our option) any defective merchandise or parts upon proof of purchase; however, transportation and delivery costs, as well as payments to a third party for assembly or disassembly of the item, remain the responsibility of the purchaser. A purchaser of an "open box," previously-returned, or "clearance" item, as well as original purchasers outside of the warranty period, may obtain replacement parts from Sunjoy Group for products in current production, at nominal cost.

## Exclusions

Items used for commercial, contract, or other non-residential purposes, or items damaged due to acts of nature, vandalism, misuse, or improper assembly are not covered. Corrosion or rusting of hardware is not covered.

Proof of purchase (dated register receipt) is required for warranty claims. Warranty is to the original purchaser and is non-transferable. Any replacement of warranted items will be in the original style and color, or a similar style and color if the original is unavailable or has been discontinued. As some states do not allow exclusions or limitations on an implied warranty, the above exclusions and limitations may not apply. This warranty gives you specific rights, and you may also have other rights, which vary from state to state.

## Care and Maintenance

- Les composants en acier de ce belvédère sont traités avec une peinture antirouille. Toutefois, en raison de la nature de l'acier, une oxydation de la surface (rouille) se produira si ces revêtements protecteurs sont égratignés. La garantie ne couvre pas ce phénomène puisqu'il ne s'agit pas d'un défaut.
- Afin de minimiser cette situation, nous recommandons d'être prudent lors de l'assemblage et de la manipulation du produit afin d'éviter d'égratigner la peinture. En cas d'égratignure ou de dommage, nous recommandons d'effectuer immédiatement une retouche avec une peinture antirouille.
- La rouille de surface peut facilement être retirée à l'aide d'une petite quantité d'huile de cuisson ordinaire ou de WD-40. Si une oxydation (rouille) de la surface se produit et qu'aucune mesure n'est prise pour corriger la situation, la rouille pourrait couler sur la terrasse et causer des taches dommageables qui peuvent être difficiles à enlever. Cela peut être évité si les mesures mentionnées ci-dessus sont prises pour empêcher l'oxydation du produit.
- N'utilisez pas d'eau de Javel, d'acide ou d'autres nettoyants abrasifs sur le toit ou les pièces du cadre.
- Conservez le manuel d'instructions pour référence future.
- Conservez l'emballage d'origine pour ranger la tonnelle.
- Vérifiez périodiquement pour vous assurer que tous les écrous sont bien serrés pendant l'utilisation.

## Garantie limitée du fabricant

Sunjoy Group garantit à l'acheteur initial que ce produit ne présentera aucun défaut de fabrication et de matériaux pendant une période de un an à compter de la date de l'achat si le produit a été acheté dans son emballage scellé à l'usine, et s'il a été entretenu correctement et utilisé à des fins personnelles et résidentielles seulement. Si le produit présente un défaut de fabrication pendant cette période de garantie, Sunjoy Group remplacera (à sa discrétion) toute marchandise ou pièce défectueuse sur présentation d'une preuve d'achat. Toutefois, les frais de transport et de manutention, ainsi que les paiements versés à un tiers pour l'assemblage ou le démontage du produit, demeurent la responsabilité de l'acheteur. Les acheteurs de produits avec « boîte ouverte », précédemment retournés ou « en liquidation », ainsi que les acheteurs initiaux de produits dont la période de garantie est terminée, peuvent obtenir des pièces de rechange auprès de Sunjoy Group pour des produits actuellement en production, à peu de frais.

## Exclusions:

les articles utilisés à des fins commerciales, locatives ou non résidentielles et les articles endommagés par des phénomènes naturels, des actes de vandalisme, un usage inapproprié ou un assemblage inadéquat ne sont pas couverts. La corrosion et la rouille de la quincaillerie ne sont pas couvertes. Une preuve d'achat (une copie de votre reçu daté) doit être présentée avec toute réclamation au titre de la garantie. La garantie n'est accordée qu'à l'acheteur initial et est non transférable. Si l'article original n'est plus offert, il sera remplacé par un article d'une couleur et d'un style similaires. Certains États ou certaines provinces ne permettent pas l'exclusion ou la limitation d'une garantie implicite, de sorte que les limitations et exclusions mentionnées ci-dessus peuvent ne pas s'appliquer à vous. Cette garantie vous confère des droits précis. Il est possible que vous disposiez également d'autres droits, qui varient d'un État ou d'une province à l'autre.