

Rubbermaid®

74 GALLON MEDIUM DECK BOX
Assembly Instructions

CAJA DE CUBIERTA MEDIANA DE 280 LITROS
Instrucciones de armado

COFFRE DE TERRASSE MOYEN DE 280 LITRES
Instructions d'assemblage

2P38

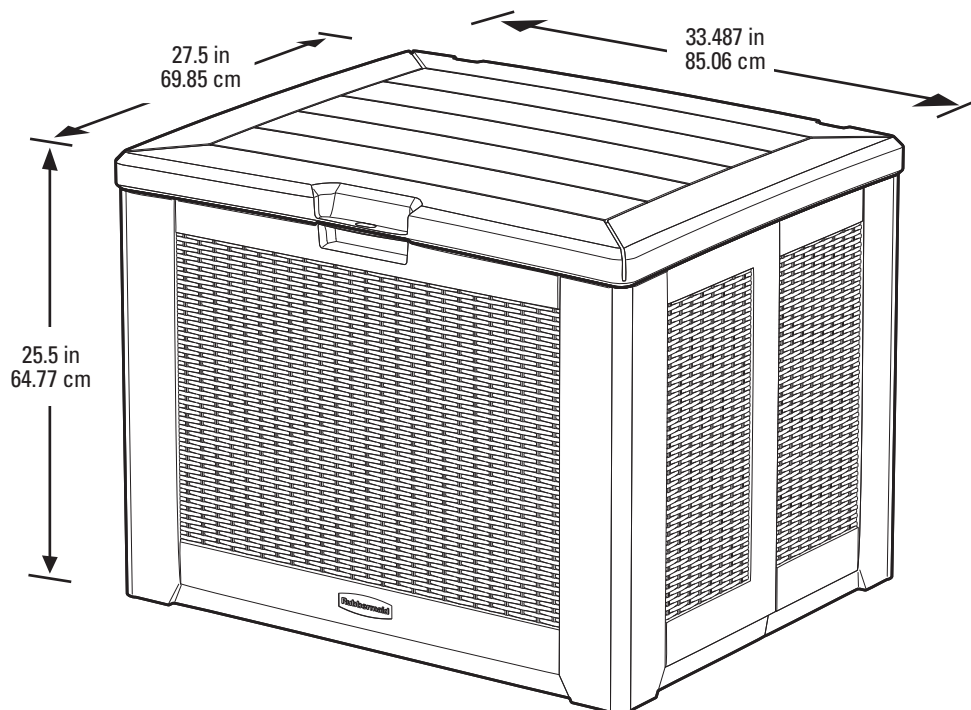

Thank you for purchasing this Rubbermaid® deck box. This dependable product was designed to look great outdoors and help keep your deck or patio organized. We want your experience to be a good one.

Please read these instructions thoroughly before assembling the deck box.

Gracias por comprar esta caja de cubierta Rubbermaid®. Este producto confiable fue diseñado para lucirse en exteriores y ayudar a mantener su terraza o patio organizados. Queremos que tenga una buena experiencia. Antes de montar la caja de cubierta, lea atentamente estas instrucciones.

Merci d'avoir acheté ce coffre de terrasse Rubbermaid®. Ce produit fiable a été conçu pour avoir une belle apparence à l'extérieur et vous aider à garder votre terrasse en ordre. Veuillez lire ces instructions attentivement avant d'assembler le coffre de terrasse.

Before you begin

1. Identify and confirm all parts and quantities using the component list on the following page.
2. Read entire instruction booklet, and follow all cautions and warnings carefully.
3. Choose a level surface for the assembly process.
4. Place parts on a protective layer, like cardboard, to help prevent damage during assembly.

If you need help

If assistance is needed, do not contact or return to the store. Call our Consumer Service Department at 1-888-895-2110 (Mon–Fri 8:30 a.m. to 5:00 p.m. EST). Keep this instruction booklet and your original store receipt to ensure our Consumer Service Department can accurately and quickly assist you.

Rubbermaid® Consumer Services Department
1-888-895-2110

www.Rubbermaid.com

Warnings, Use & Care

- Always use gloves when handling metal components.
 - Always use eye protection (safety glasses) during assembly.
-  When installing screws, do not overtighten.
- Do not stand on product.
 - Do not store hot items in or on this product.
 - Keep this product on a flat, level surface.
 - When necessary, this product may be cleaned with water and a mild detergent. Do not use abrasive detergents, materials or cleaning tools.
 - Keep lid closed and secured when not in use.
 - To maximize your product's performance, remove excessive snow and debris accumulation from the lid.
 - Product may get hot when in direct sunlight.

Antes de comenzar

1. Identifique todas las piezas y verifique las cantidades con la lista de componentes de la siguiente página.
2. Lea todo el manual de instrucciones y siga atentamente todas las precauciones y las advertencias.
3. Escoja una superficie nivelada para el proceso de armado.
4. Coloque las partes en una superficie de protección, como cartón, para evitar daños durante el montaje.

Si necesita ayuda

Si necesita asistencia, no llame a la tienda ni devuelva el producto. Llame a nuestro Departamento de Atención al Cliente al 1-888-895-2110 (de lunes a viernes, de 8:30 a. m. a 5:00 p. m. EST). Guarde este manual de instrucciones y la factura original de su tienda para garantizar que nuestro Departamento de Atención al Cliente pueda ayudarlo rápida y correctamente.

Rubbermaid® Consumer Services Department
1-888-895-2110

www.Rubbermaid.com

Advertencias, uso y mantenimiento

- Siempre use guantes al manipular los componentes metálicos.
 - Siempre utilice protección para los ojos (gafas de seguridad) durante el armado.
-  No ajuste los tornillos en exceso.
- No se pare sobre el producto.
 - No almacene elementos calientes en este producto ni sobre él.
 - Mantenga este producto sobre una superficie plana y nivelada
 - Si es necesario, este producto puede limpiarse con agua y detergente neutro. No utilice detergentes, herramientas de limpieza ni materiales abrasivos.
 - Mantenga la tapa cerrada y sujeta cuando no use el producto.
 - Para maximizar el desempeño del producto, quite el exceso de nieve o de escombros de la tapa.
 - El producto puede calentarse bajo la luz solar directa.

Avant de commencer

1. Déterminez les pièces et la quantité de chacune à l'aide de la liste des composantes qui se trouve à la page suivante.
2. Lisez le livret d'instructions au complet et suivez attentivement toutes les instructions et les mises en garde.
3. Choisissez une surface plane pour l'assemblage.
4. Placez les pièces sur une surface protectrice, comme du carton, pour éviter de les endommager pendant le montage.

Si vous avez besoin d'aide

Si vous avez besoin d'aide, ne communiquez pas avec le magasin et ne retournez pas le produit. Appelez notre service aux consommateurs au 1-888-895-2110 (lun. au ven. de 8 h 30 à 17 h HNE). Veuillez garder le présent livret d'instructions et le reçu du magasin afin que notre service aux consommateurs puisse vous aider adéquatement.

Rubbermaid® Consumer Services Department
1-888-895-2110

www.Rubbermaid.com

Mises en garde, utilisation et entretien

- Utilisez toujours des gants quand vous manipulez des composantes en métal.
- Utilisez toujours une protection des yeux (lunettes de protection) pendant l'assemblage.
- ⚠ Ne serrez pas trop les boulons lorsque vous les installez.
- Ne montez pas sur le produit.
- Ne déposez pas d'objets chauds sur cet article.
- Gardez cet article sur une surface plane.
- Au besoin, cet article peut être nettoyé avec de l'eau et un savon doux. N'utilisez pas des détergents, des solutions ou des outils abrasifs.
- Gardez le couvercle fermé et sécurisé lorsque vous ne vous servez pas de l'article.
- Afin de prolonger la durée de vie de l'article, enlevez la neige et les débris excédentaires s'ils s'accumulent sur le couvercle.
- Le produit peut devenir chaud s'il est laissé au soleil.

Tools required / Outils requis / Herramientas necesarias



Safety Glasses

Gafas de seguridad

Lunettes de sécurité



Gloves

Guantes

Gants



7/16" Combination Wrench

7/16" Llave combinada

7/16" Clé mixte



Phillips Screwdriver

Destornillador de cabeza Phillips

Tournevis Phillips

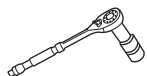

7/16" Ratchet

Llave de torque 7/16"

Clé à cliquet 7/16 po



Drill

Taladro

Perceuse

Phillips Bit
Broca Phillips | Pointe Phillips



DO NOT overtighten screws!

¡NO ajuste los tornillos en exceso!

ÉVITEZ de trop serrer les boulons!

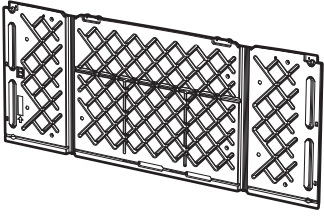

B - 1

W2 Medium Deck Box Back Panel

W2 Panel posterior de la caja de cubierta mediana

W2 Panneau arrière du coffre de terrasse moyen

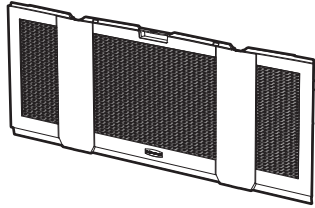

A - 1

W2 Medium Deck Box Front Panel

W2 Panel delantero de la caja de cubierta mediana

W2 Panneau avant du coffre de terrasse moyen



F - 1

W2 Medium Deck Box Floor Panel

W2 Panel de piso de la caja de cubierta mediana

W2 Panneau de plancher du coffre de terrasse moyen

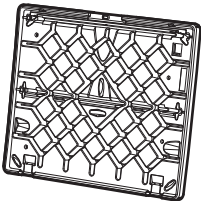

L - 1

W2 Medium Deck Box Lid Panel

W2 Panel de la tapa de la caja de cubierta mediana

W2 Panneau de couvercle du coffre de terrasse moyen



LS - 1

W2 Medium Deck Box Lid Support

W2 Soporte de la tapa de la caja de cubierta mediana

W2 Support de couvercle du coffre de terrasse moyen

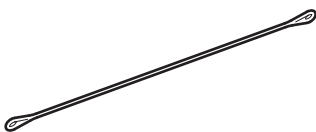

T - 2

Tether

Correa

Attache



CB - 2

W2 Connector Bracket

W2 Soporte del conector

W2 Support de connecteur



CP - 4

W2 Connector Pin

W2 Clavija del conector

W2 Broche de connecteur

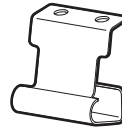

HB - 2

W2 Hinge Bracket

W2 Soporte de la bisagra

W2 Support de charnière



HP - 2

W2 Hinge Post

W2 Poste de la bisagra

W2 Tige de charnière



AA - 14

#14 x 0.50 Phillips Pan "A" Head SMS

#14 x 0.750 Tornillo Phillips Pan "A" Head SMS

#14 x 0.750 Vis de mécanique à tête cylindrique large Phillips « A »



EE - 4

1/4"-20 UNC Hex Nylon Lock Nut

1/4"-20 UNC Tuerca de bloqueo hexagonal con nylon

1/4"-20 UNC Écrou freiné hexagonal en nylon

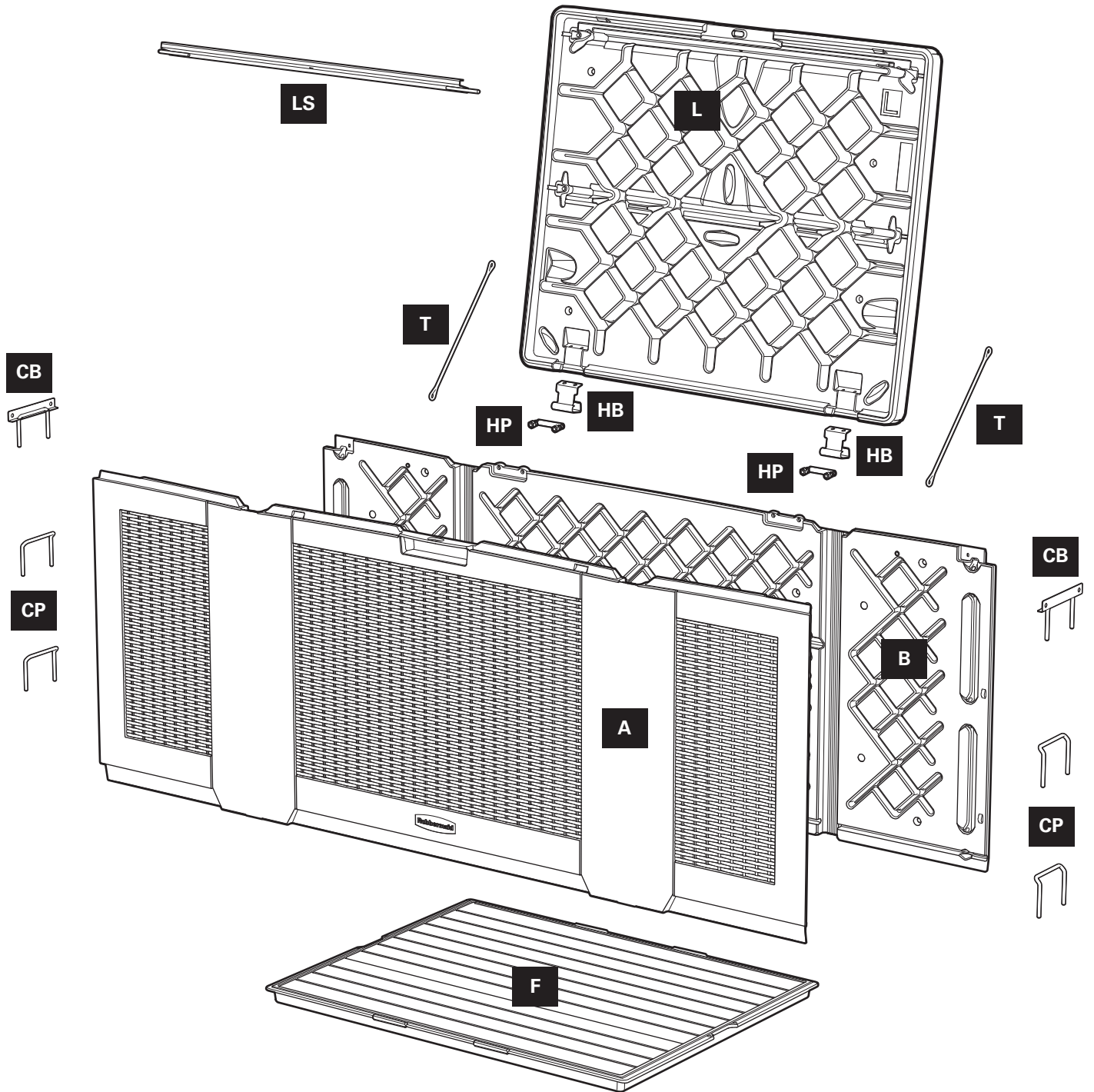

1

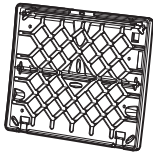

L 1



T 2



AA 2



DO NOT overtighten screws!

¡NO ajuste los tornillos en exceso!

ÉVITEZ de trop serrer les boulons!

1.a

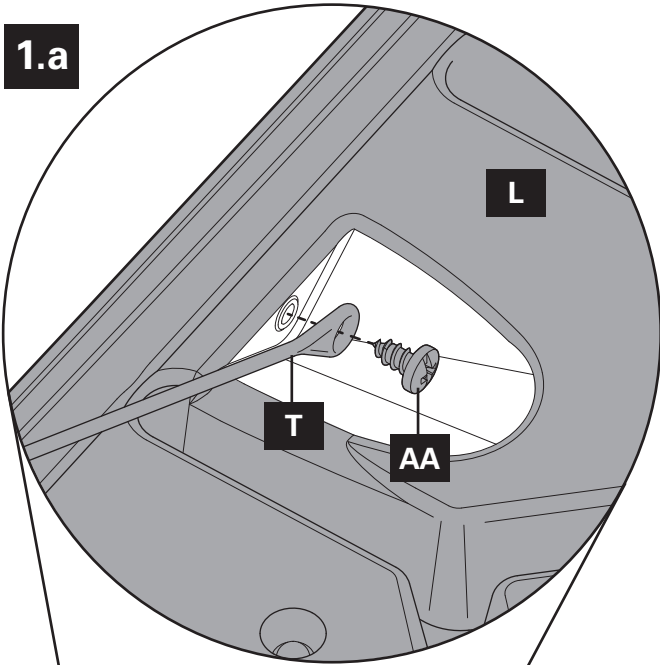

1.b

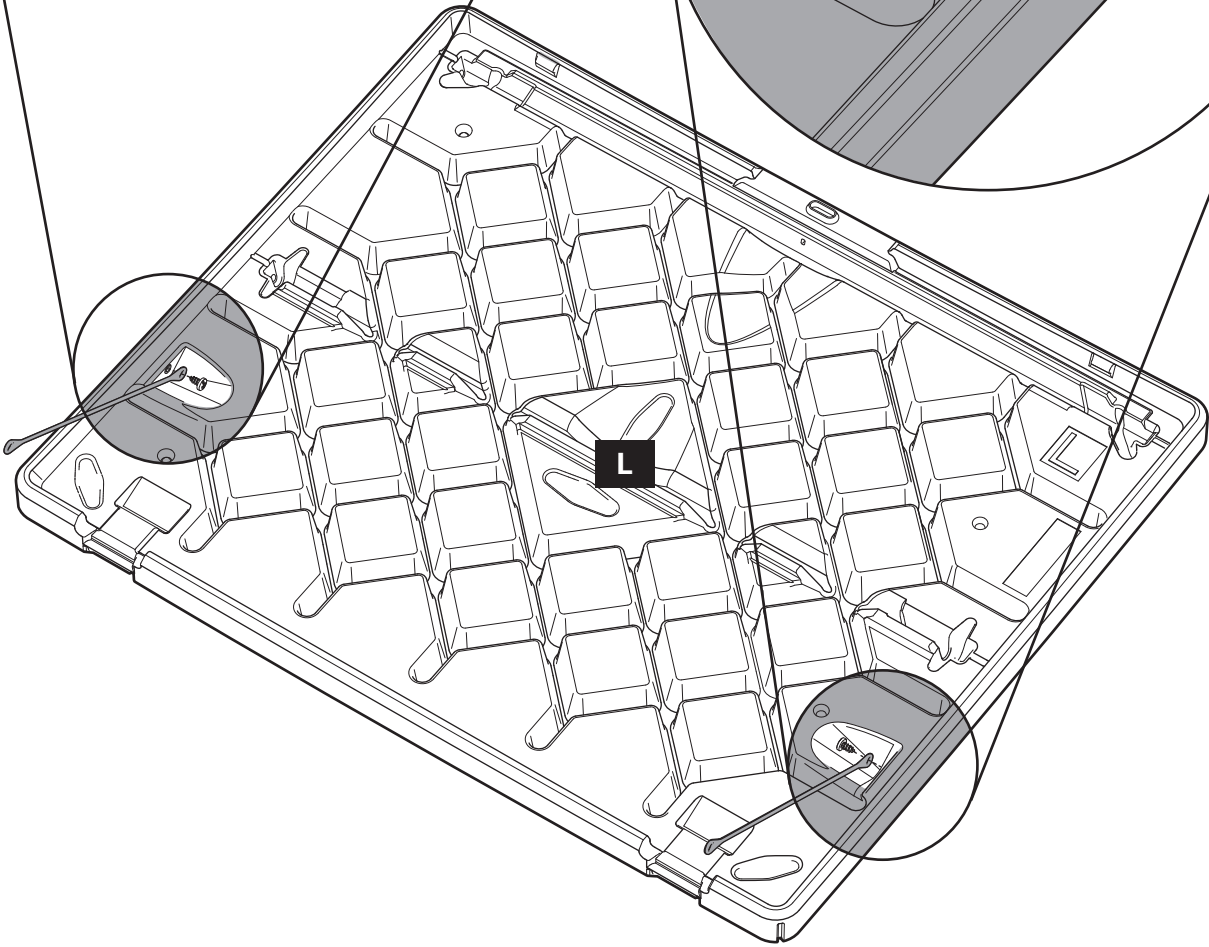
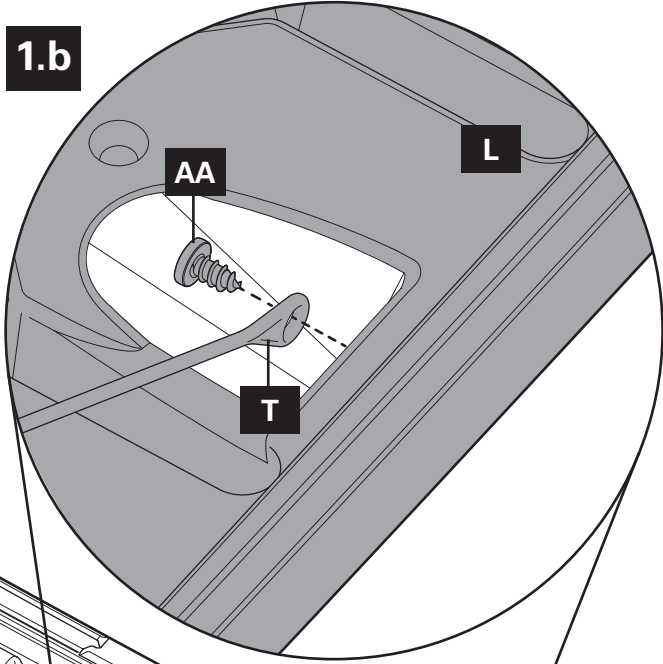

2

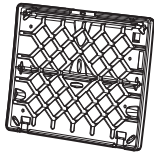

L 1



LS 1



AA 1



DO NOT overtighten screws!
¡NO ajuste los tornillos en exceso!
ÉVITEZ de trop serrer les boulons!

2.a

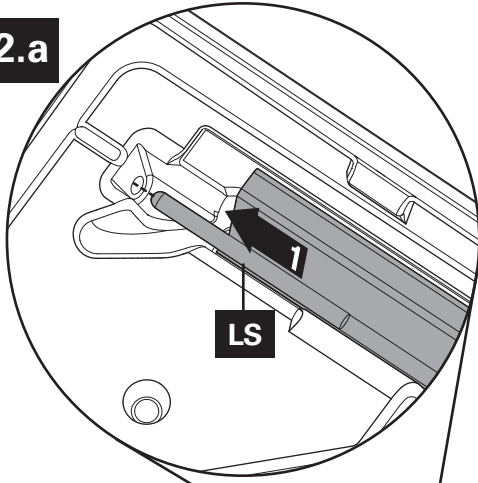

2.b

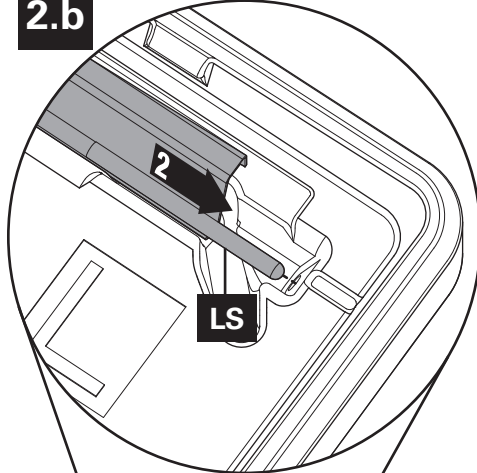

2.c

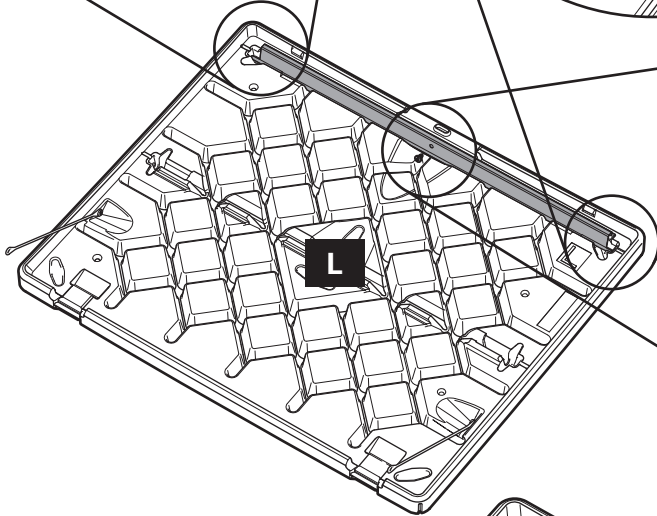
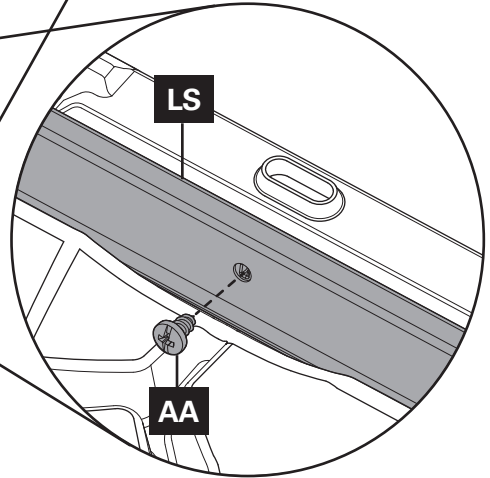

STEP 2 COMPLETE
PASO 2 COMPLETO
FIN DE L'ÉTAPE 2

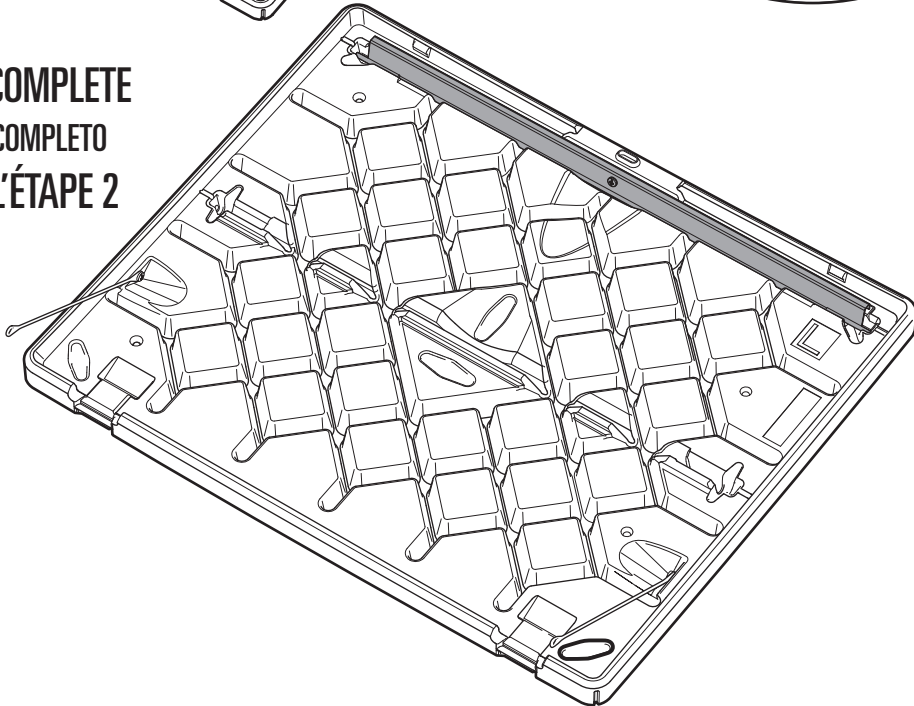

3

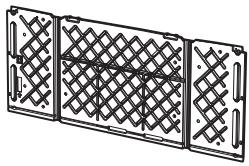

B 1

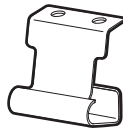

HB 2



HP 2



EE 4

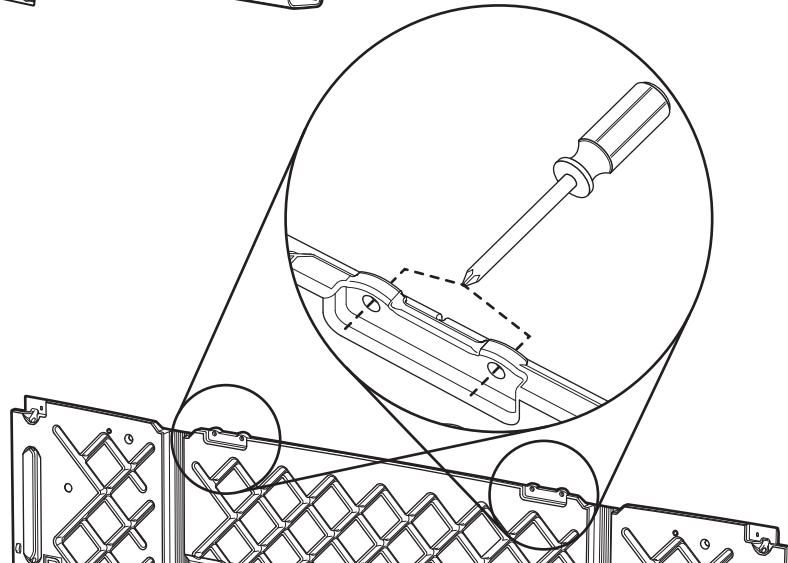

USING A SCREWDRIVER, CLEAR THE HOLES AT HINGE POST LOCATIONS, 4 PLACES

CON UN DESTORNILLADOR, DESPEJE LOS AGUJEROS EN LAS UBICACIONES DEL POSTE DE LA BISAGRA, 4 LUGARES

À L'AIDE D'UN TOURNEVIS, ÉVIDEZ LES TROUS AUX EMBLEMES DES TIGES DE CHARNIÈRE, À 4 ENDRITS

3.a

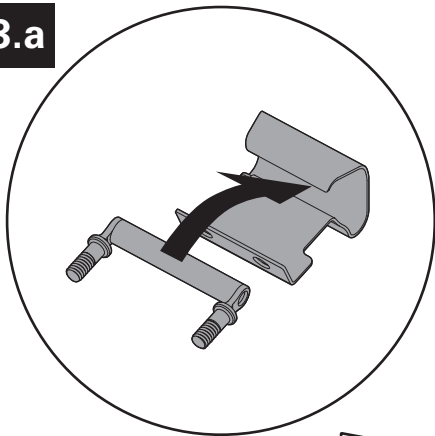

3.b

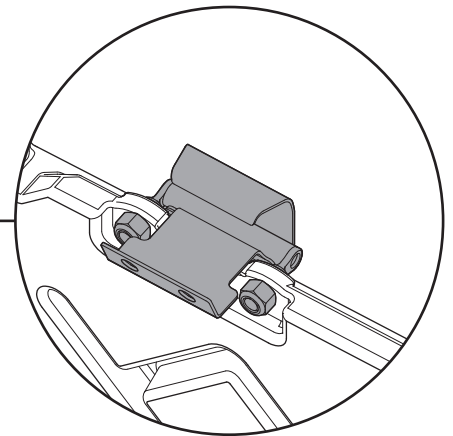
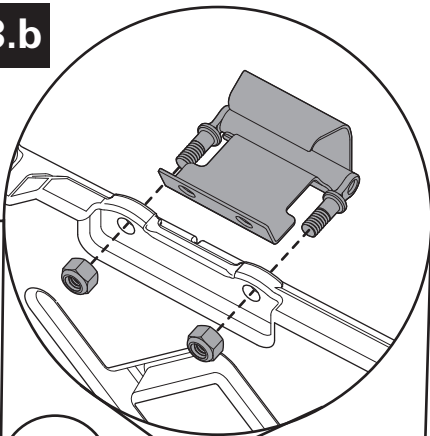

STEP 3 COMPLETE
PASO 3 COMPLETO
FIN DE L'ÉTAPE 3

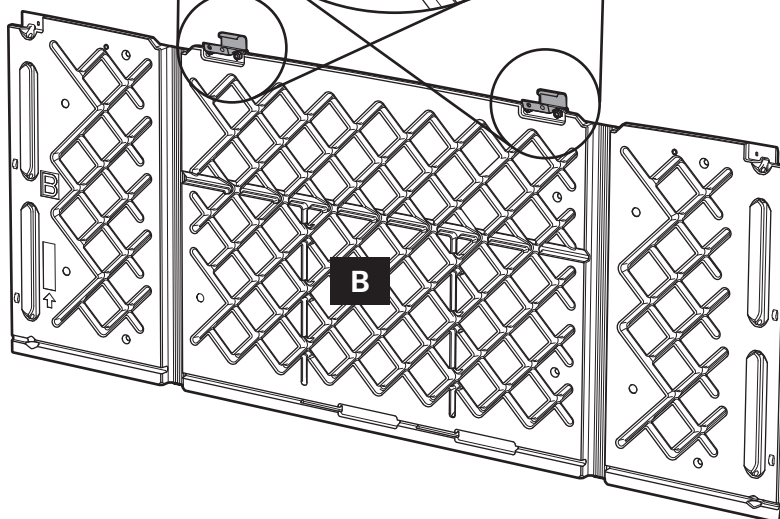

4

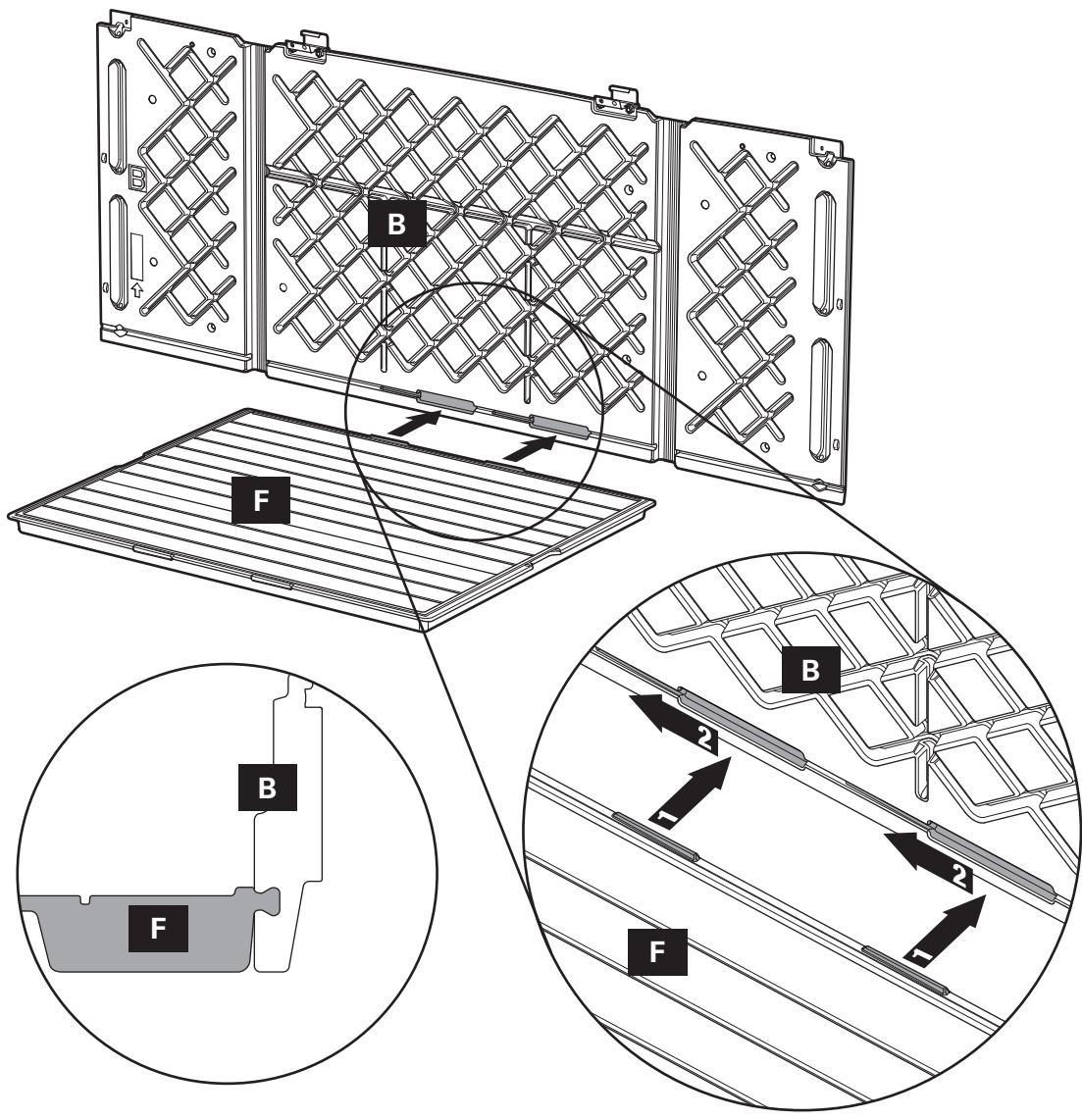
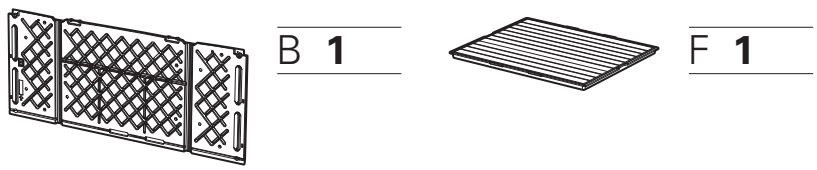

STEP 4 COMPLETE
PASO 4 COMPLETO
FIN DE L'ÉTAPE 4

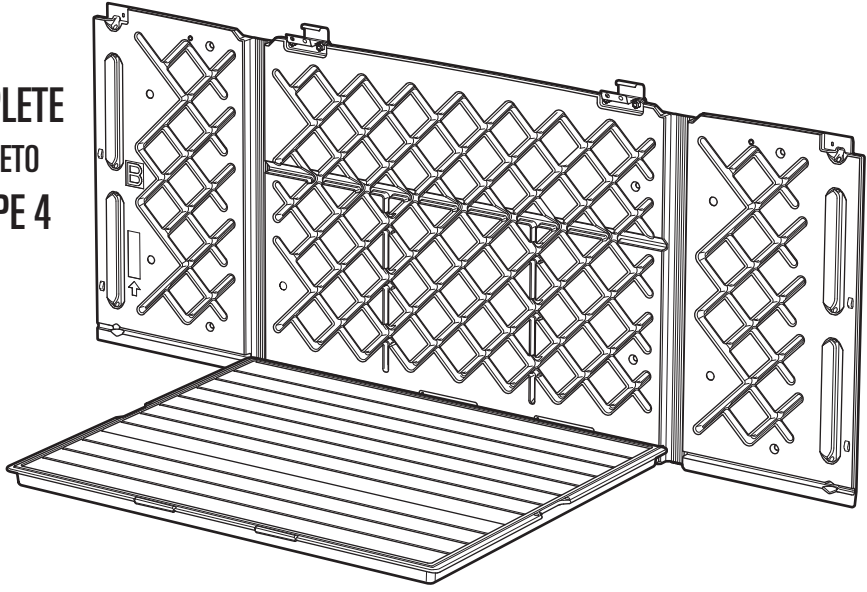

5

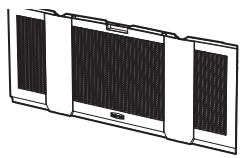

A 1

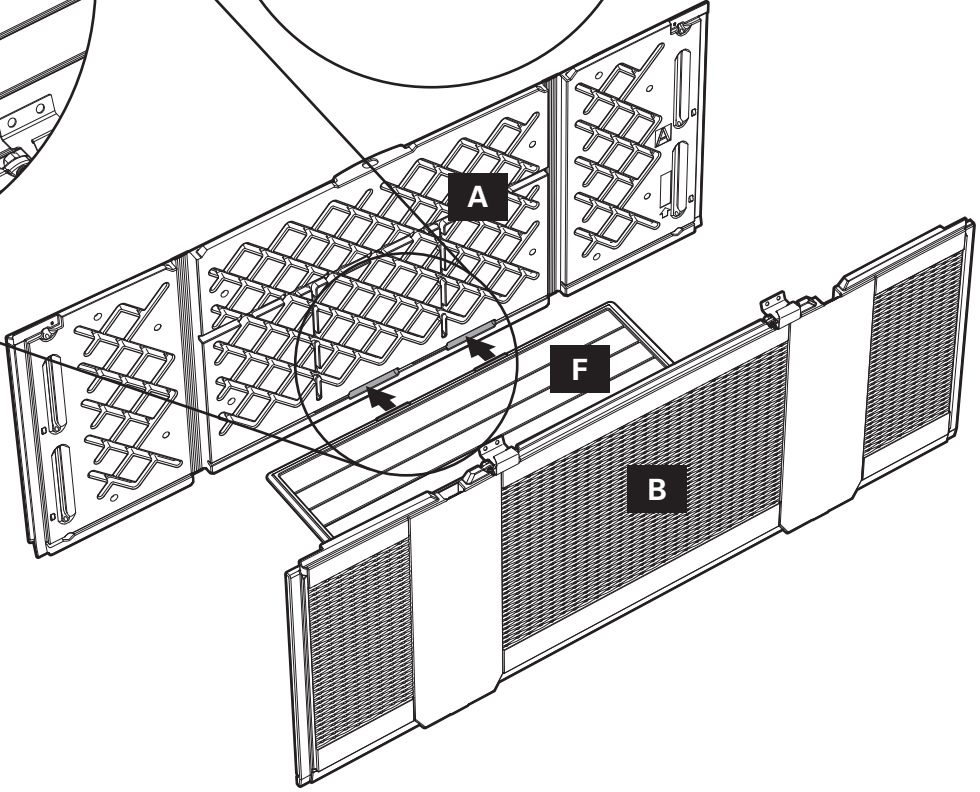
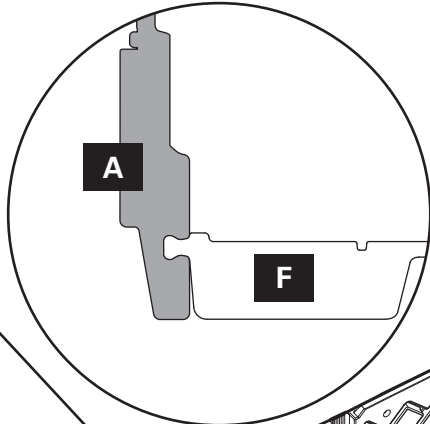
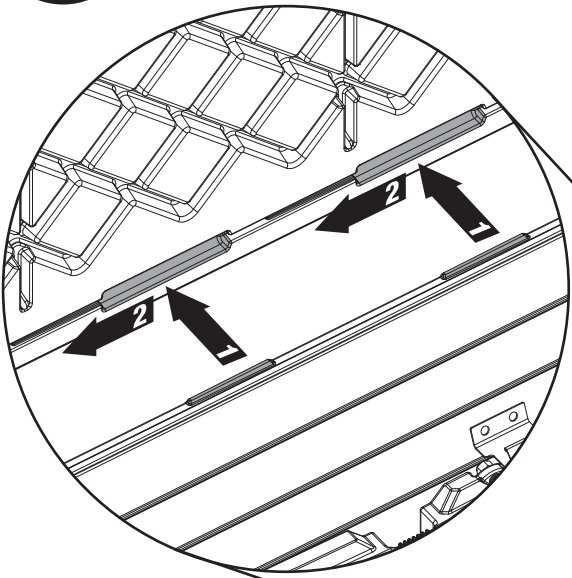

STEP 5 COMPLETE
PASO 5 COMPLETO
FIN DE L'ÉTAPE 5

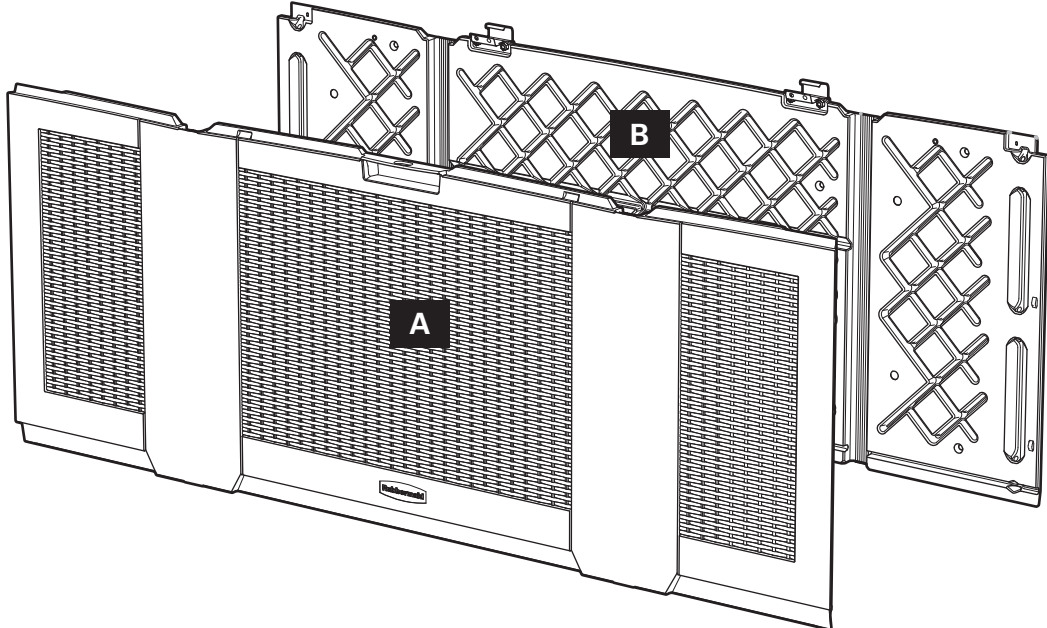

6

 **CB 2**  **CP 4**  **AA 4**

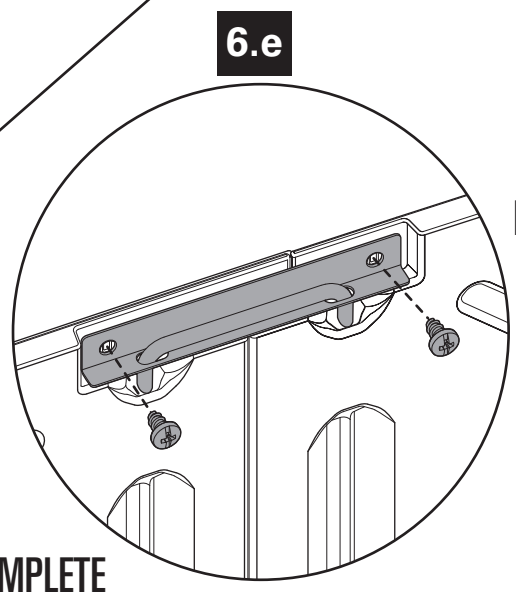
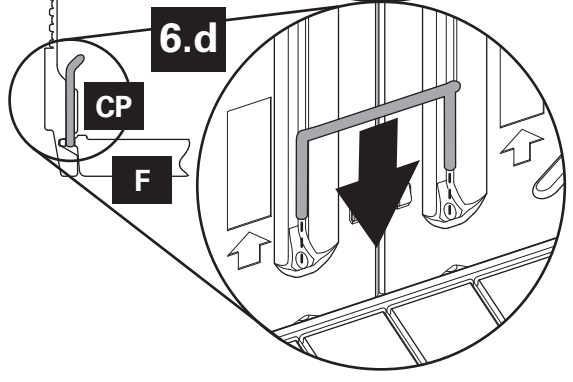
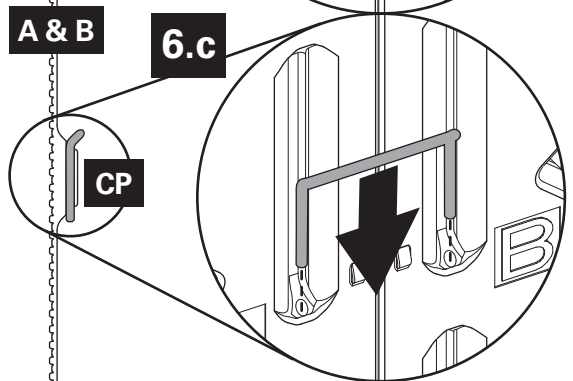
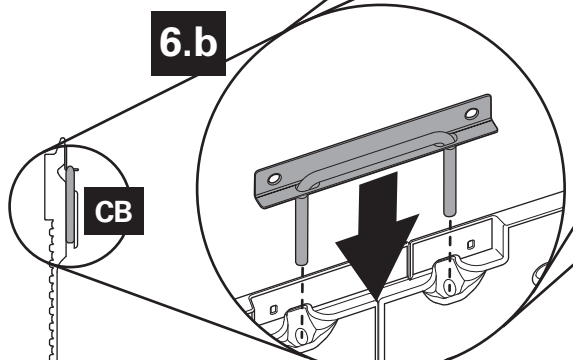
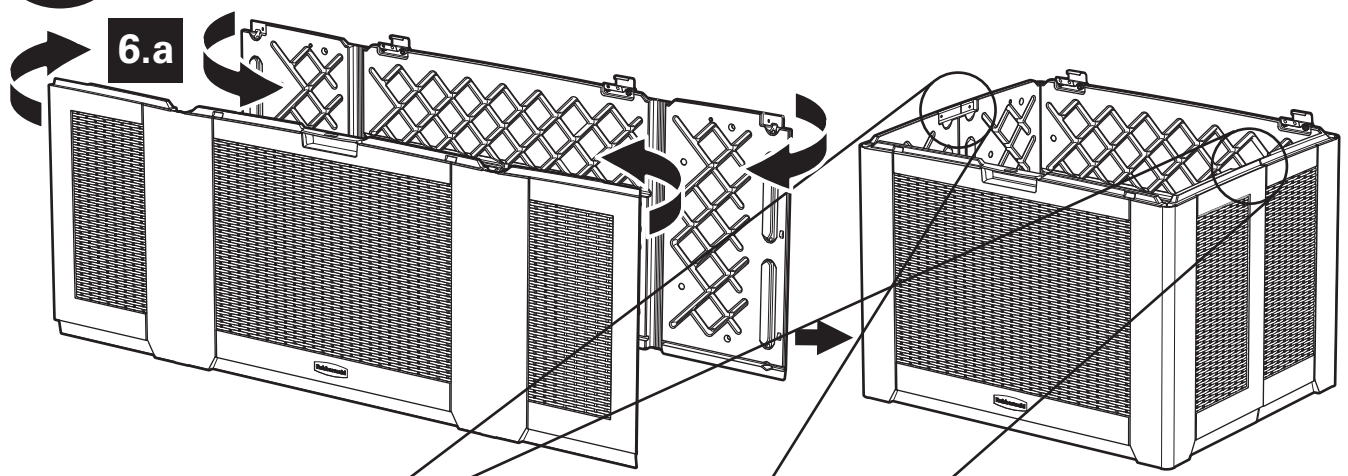

6.f
REPEAT
RÉPÉTER
REPETIR

STEP 6 COMPLETE
PASO 6 COMPLETO
FIN DE L'ÉTAPE 6

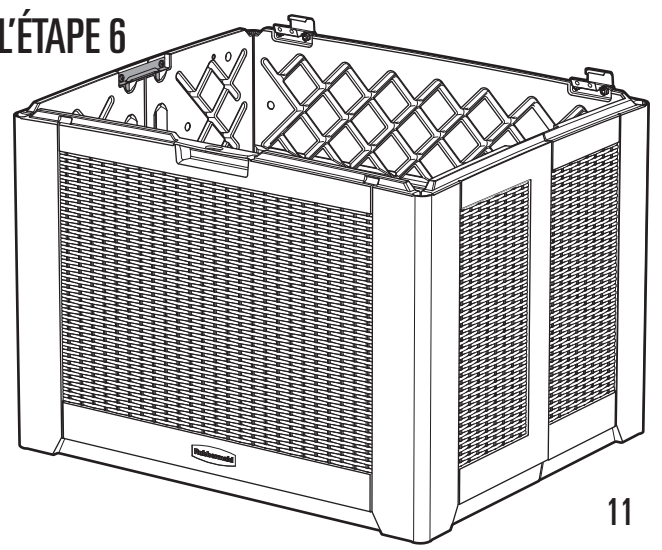

7

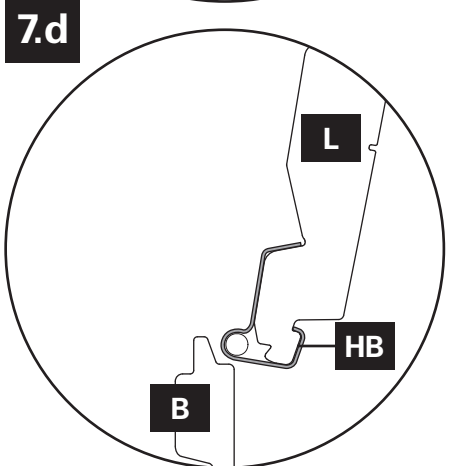
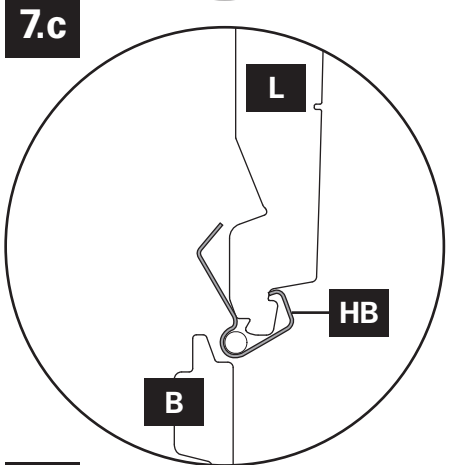
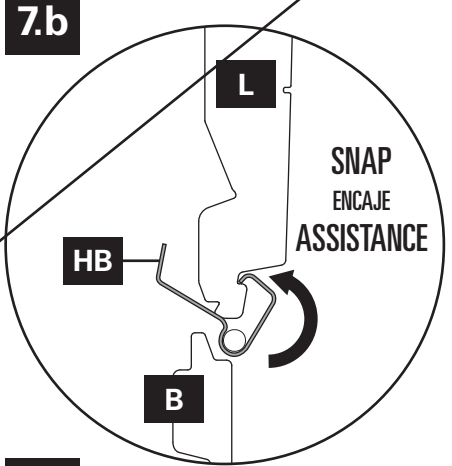
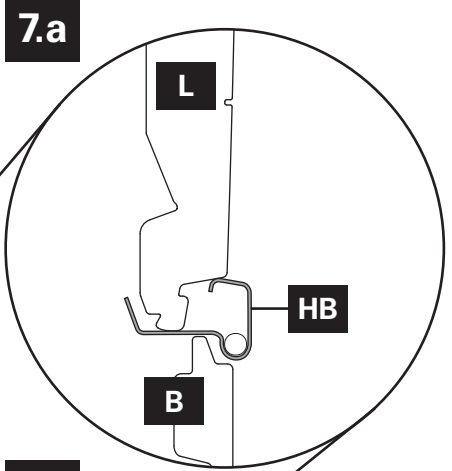
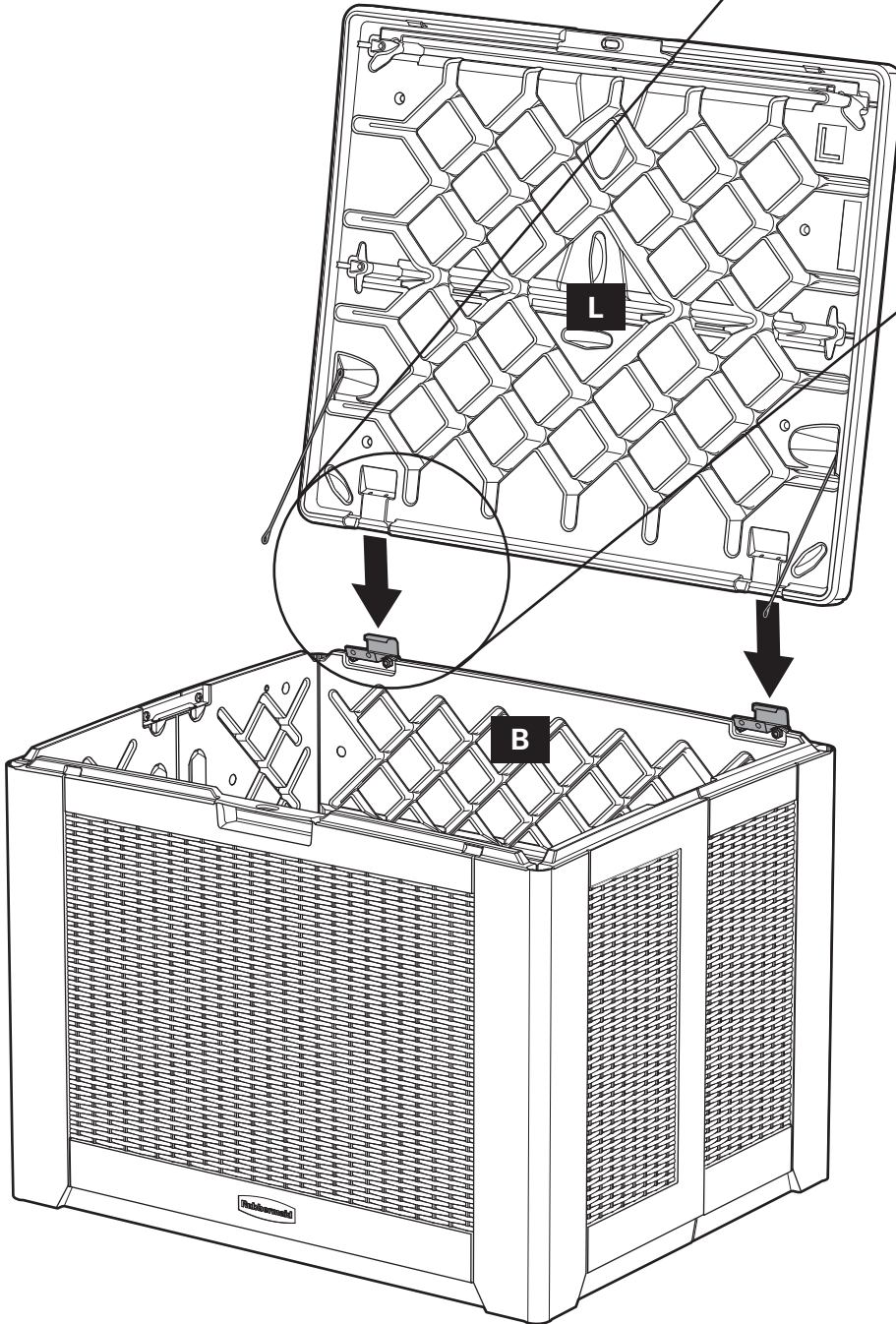
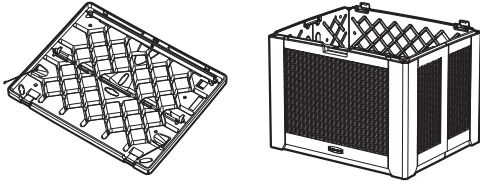

7

Continued
Suite
Continuación



AA 6



DO NOT overtighten screws!
¡NO ajuste los tornillos en exceso!
ÉVITEZ de trop serrer les boulons!

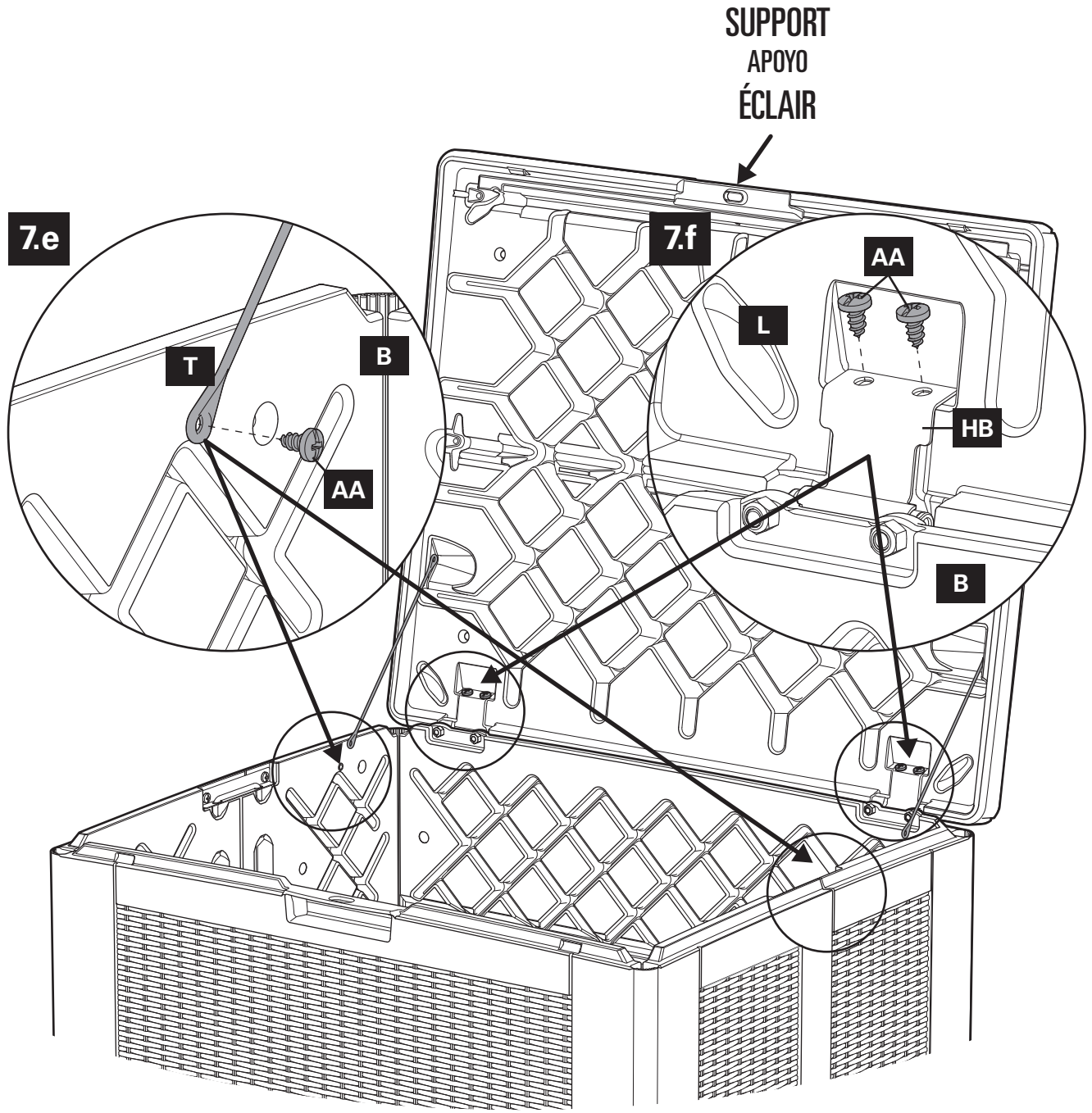

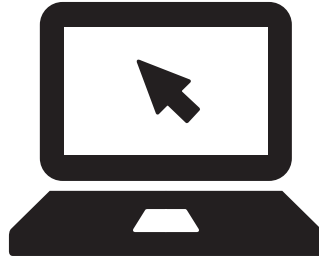

Visit www.rubbermaid.com/deck-boxes for helpful tips and information.
To register this product, visit www.rubbermaid.com/registration. You will need the four-character model number, located on the front page of the assembly instructions above the product image, and date of purchase to complete registration.

Visite www.rubbermaid.com/deck-boxes para información y consejos útiles.

Para registrar este producto, visite www.rubbermaid.com/registration. Necesitará el número de modelo de cuatro caracteres, que se encuentra en la primera página de las instrucciones de montaje arriba de la imagen del producto, y la fecha de compra para completar el registro.

Visitez www.rubbermaid.com/deck-boxes pour des conseils pratiques et de l'information.

Pour enregistrer ce produit, rendez-vous sur www.rubbermaid.com/registration. Le numéro de modèle à quatre caractères, figurant sur la première page des instructions de montage au-dessus de l'image du produit, et la date d'achat sont nécessaires pour enregistrer le produit.



YOU'RE DONE! Remember, if you have any trouble, don't call or return to the store. Call our Consumer Service Department at 1-888-895-2110 (Mon–Fri 8:30 a.m. to 5:00 p.m. EST). Keep this instruction booklet and your original store receipt to ensure our Consumer Service Department can accurately and quickly assist you.

¡YA ESTÁ! Recuerde, si tiene problemas, no llame a la tienda ni devuelva el producto. Llame a nuestro Departamento de Atención al Cliente al 1-888-895-2110 (de lunes a viernes, de 8:30 a. m. a 5:00 p. m. EST). Guarde este manual de instrucciones y la factura original de su tienda para garantizar que nuestro Departamento de Atención al Cliente pueda ayudarlo rápida y correctamente.

TERMINÉ! Rappel : si vous avez des difficultés, appelez au magasin ou retournez l'article. Appelez notre service aux consommateurs au 1-888-895-2110 (lun. au ven. de 8 h 30 à 17 h HNE). Veuillez garder le présent livret d'instructions et le reçu du magasin afin que notre service aux consommateurs puisse vous aider adéquatement.