



# ASSEMBLY INSTRUCTIONS

Pour le français, voir la page 2. Para el español, ver la página 3.

## 8' x 10' OUTDOOR STORAGE SHED

MODEL 60117

### BEFORE ASSEMBLY:

- Assemble on a level surface
- 3+ people recommended for setup



### TOOLS REQUIRED

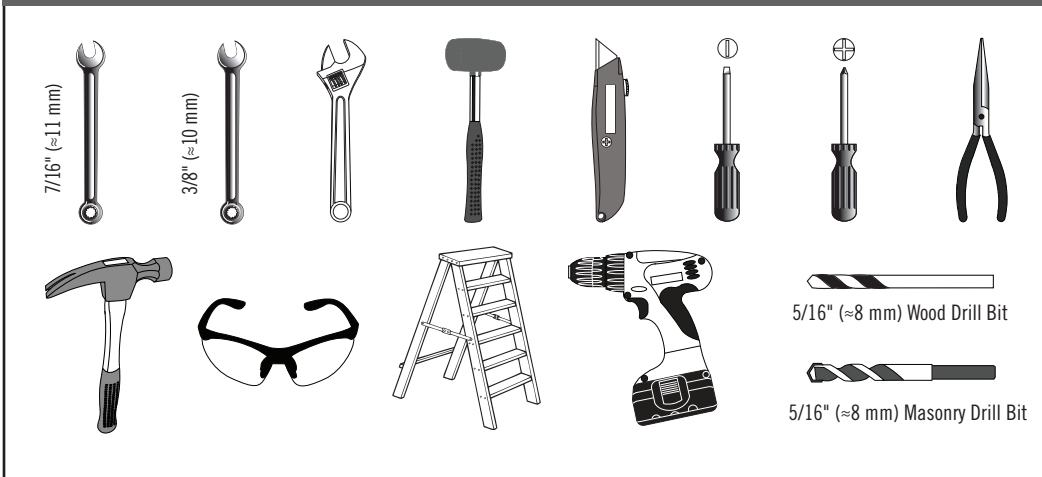

### TABLE OF CONTENTS

Icon Legend.....	4
Warnings & Notices.....	5
Platform Construction.....	6
Truss Assembly.....	11
Gable Assembly.....	16
Door Assembly.....	21
Floor Assembly.....	28
Wall Assembly.....	31
Shelving Installation.....	37
Parts Identifier.....	39
Door & Gable Installation.....	44
Roof Assembly.....	48
Window Installation.....	63
Door Alignment.....	67
Shed Anchoring.....	69
Cleaning & Care.....	72
Registration.....	73
Warranty.....	77

### QUESTIONS?

Call: **1-800-225-3865**  
 7:00 am - 5:00 pm (Monday–Friday) MST  
 and 9:00 am–1:00 pm Saturday MST

### CONTACT LIFETIME® CUSTOMER SERVICE:

Web: [www.lifetime.com/customerservice](http://www.lifetime.com/customerservice)  
 (Cliquer la languette « LIVE CHAT »)  
 For Customer Service in Mainland Europe and the United Kingdom,  
 E-mail: [cs@lifetimeproducts.eu](mailto:cs@lifetimeproducts.eu)

MODEL# AND PRODUCT ID (both are needed when contacting us)

Model Number: **60117** Product ID:



# INSTRUCTIONS D'ASSEMBLAGE

For English, see page 1. Para el español, ver la página 3.

## ABRI DE JARDIN DE 2,44 m x 3,05 m

**MODÈLE n° 60117**

### AVANT L'ASSEMBLAGE :

- Assembler sur une surface de niveau
- Nous recommandons, au moins, 3 adultes pour l'assemblage



### OUTILS REQUIS



### SOMMAIRE

Légende des icônes.....	4
Avertissements et avis.....	5
Assemblage de la plate-forme.....	6
Assemblage des fermes.....	11
Assemblage des pignons.....	16
Assemblage des portes.....	21
Assemblage du plancher.....	28
Assemblage des murs.....	31
Installation du rayonnage.....	37
Identificateur de pièces.....	39
Installation des portes.....	44
Assemblage du toit.....	48
Installation des carreaux.....	63
Alignement des pièces.....	67
L'ancrage de l'abri.....	69
Nettoyage et entretien.....	72
Enregistrement.....	73
Garantie.....	78

### QUESTIONS ?

### CONTACTER AUX SERVICES À LA CLIENTÈLE LIFETIME® :

Composer le **1-800-225-3865**  
 Du lundi au vendredi 7 h – 17 h (HNR)  
 et samedi 9 h – 13 h (HNR)

Entretien en direct: [www.lifetime.com/customerservice](http://www.lifetime.com/customerservice)  
 (cliquer sur la languette « LIVE CHAT »)  
 Pour nos services à la clientèle du continent européen et au Royaume-Uni,  
 É-mail : [cs@lifetimeproducts.eu](mailto:cs@lifetimeproducts.eu)

**N° DE MODÈLE ET RÉFÉRENCE DU PRODUIT**  
 (il faut avoir les deux en entrant en contact avec nous)  
 N° de modèle : **60117**  
 Référence du produit :



# INSTRUCCIONES DE ENSAMBLAJE

For English, see page 1. Pour le français, voir la page 2.

## CASETA DE JARDIN DE 2,44 m x 3,05 m

MODELO n° 60117

### ANTES DE ENSAMBLAR:

- Ensamblar sobre una superficie nivelada
- Recomendamos, por lo menos, 3 adultos para el ensamblaje



INSTRUMENTAL REQUERIDO	ÍNDICE
<p>7/16" (≈11 mm)</p> <p>3/8" (≈10 mm)</p> <p>5/16" (≈8 mm) Broca para madera</p> <p>5/16" (≈8 mm) Broca de albañilería</p>	<p>Leyenda de íconos.....4</p> <p>Advertencias y avisos.....5</p> <p>Ensamblaje de la plataforma.....6</p> <p>Ensamblaje de las cerchas.....11</p> <p>Ensamblaje de las fachadas.....16</p> <p>Ensamblaje de las puertas.....21</p> <p>Ensamblaje del piso.....28</p> <p>Ensamblaje de los muros.....31</p> <p>Instalación de los estantes.....37</p> <p>Identificador de piezas.....39</p> <p>Instalación de las puertas.....44</p> <p>Ensamblaje del tejado.....48</p> <p>Instalación de las hojas de ventana.....63</p> <p>Alineación de la puertas.....67</p> <p>Anclaje de la caseta.....69</p> <p>Limpieza y cuidado.....72</p> <p>Registro.....73</p> <p>Garantía.....79</p>

<p><b>¿PREGUNTAS?</b></p> <p>Marcar : 1-800-225-3865</p> <p>De lunes hasta viernes 7:00 h–17:00 h (MST)</p> <p>y sábado 9:00 h–13:00 h (MST)</p>	<p><b>PONERSE EN CONTACTO CON LOS SERVICIOS DE CLIENTES LIFETIME®:</b></p> <p>Chat en vivo: <a href="http://www.lifetime.com/customerservice">www.lifetime.com/customerservice</a></p> <p>(clicar en la lengüeta «LIVE CHAT»)</p> <p>Pour nos services à la clientèle du continent européen et au Royaume-Uni, ID del producto:</p> <p>É-mail : <a href="mailto:cs@lifetimeproducts.eu">cs@lifetimeproducts.eu</a></p> <p><b>MODEL E ID DEL PRODUCTO</b> (se necesitan los dos al contactarnos)</p> <p>Número de modelo: 60117</p> <p>ID del producto:</p>
--	--



## ICON LEGEND / LÉGENDE DES ICÔNES / SIGNIFICADO DE LOS ÍCONOS



- Indicates special heed should be taken when reading.
- Indique qu'une attention spéciale doit être portée à la lecture.
- Indica que uno debe prestar atención al leer.

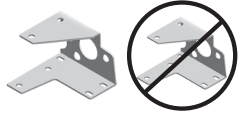

- Indicates the parts/no parts required for a section.
- Indique les pièces à utiliser/qu'aucune pièce n'est requise pour une section.
- Indica las piezas que se usarán/que no necesitan en una sección.



- Indicates the hardware to be used for a section.
- Indique la quincaillerie à utiliser pour une section.
- Indica los artículos de ferretería que se usarán para una sección.



- Indicates no hardware required for a specific page or section.
- Indique qu'aucun matériel n'est requis pour une page précise.
- Indica que no se necesitan los artículos de ferretería para una página específica.



- Indicates the tools to be used for a section.
- Indique les outils à utiliser pour une section.
- Indica las herramientas que se utilizarán para una sección.



- Indicates to use/not use an electric drill for a specific step.
- Indique quand utiliser une/que ne pas utiliser de perceuse électrique pour une étape précise.
- Indica la utilización de/que no utilizar un taladro eléctrico para un paso específico.



- These nuts are centerlock nuts. They are designed to be tight; therefore, they will be harder to tighten. Tighten until flush with the metal or plastic.
- Ces écrous sont des écrous de blocage central. Ils sont conçus pour être serrés; de ce fait, ils seront plus difficiles à resserrer. Serrer jusqu'à ce qu'ils soient au ras du métal ou du plastique.
- Estas tuercas son tuercas de bloqueo central. Están diseñadas para estar apretadas; por lo tanto, serán más difíciles de apretar. Apriételas hasta que estén al ras del metal o plástico.





## WARNINGS & NOTICES / AVERTISSEMENTS ET AVIS / ADVERTENCIAS Y AVISOS

### English:

- **Failure to follow these warnings may result in serious injury or property damage and will void warranty.**
- To ensure safety, do not attempt to assemble this product without following the instructions carefully.
- Consult all local building codes to verify if the shed requires a building permit.
- Verify the foundation is completely level before assembling the shed.
- Be aware that plastic pieces can be damaged by overtightening the screws. To avoid damage, we strongly recommend the use of a drill with a low torque setting. A #2 Phillips screwdriver may also be used.
- Three capable adults are required for assembly.
- All who participate in the assembly process should wear safety glasses throughout the assembly.
- If using a ladder during assembly, use extreme caution.
-  In heavy snowfall areas, we recommend removing snow from the roof. Remove the snow from the roof when the depth of snow equals the length of your hand.
- Do not use or store hot objects near the product.
- Proper and complete assembly are essential to reduce the risk of accident or injury.
- When drilling through metal, beware of burrs, shavings and other sharp edges.
- During and after assembly, do not slide or lift the shed by pushing up on the roof. Move the shed by pushing on the corner panels only.
- We strongly recommend anchoring your shed when it is finished. The last section, *Shed Anchoring*, in this manual shows the hardware you will need to complete the anchoring. You can find the hardware at your local hardware store.
- **Most injuries are caused by misuse and/or not following instructions. Use caution when using this product.**

### Français :

- **Ne pas suivre ces avertissements peut entraîner des blessures graves ou des dommages à la propriété et annulera la garantie.**
- Afin d'assurer la sécurité, ne pas tenter d'assembler ce produit sans suivre attentivement les instructions.
- Consulter tous les codes du bâtiment afin de vérifier si l'abri nécessite un permis de construire.
- Vérifier que la fondation est complètement à niveau avant l'assemblage de l'abri.
- Ne pas oublier que les pièces de plastique peuvent être endommagées en serrant trop les vis. Afin d'éviter les dommages, nous recommandons fortement l'utilisation d'une perceuse à faible couple. Un tournevis cruciforme n° 2 peut aussi être utilisé.
- Trois adultes en bonne condition physique sont nécessaires pour l'assemblage.
- Tout ceux qui participent au processus de l'assemblage doivent porter des lunettes de sécurité tout au long de l'assemblage.
- Si une échelle est utilisée pour l'assemblage, il faut être extrêmement prudent.
-  Dans les zones de fortes tombées de neige, il est recommandé de dégager le toit. Enlever la neige du toit quand la profondeur est égale à la longueur de la main.
- Ne pas utiliser ou entreposer des objets très chauds près de ce produit.
- Un bon assemblage complet est nécessaire pour réduire le risque d'accident ou de blessure.
- En perçant le métal, faire attention aux bavures, copeaux et autres bords aiguisés.
- Pendant et après l'assemblage, ne pas faire glisser ou soulever l'abri en poussant le toit vers le haut. Déplacer l'abri en poussant les panneaux muraux angulaires seulement.
- Il est fortement recommandé d'ancrer l'abri lorsque l'assemblage est terminé. La dernière section, *Ancrage de l'abri*, de ce manuel indique les matériaux nécessaires pour l'ancrage. Les matériaux se trouvent dans la quincaillerie locale.
- **La majorité des blessures sont causées par une mauvaise utilisation et/ou le non suivi des instructions. Être prudent en utilisant ce produit.**

### Español:

- **No seguir estas advertencias puede resultar en lesiones graves o daños a la propiedad y anulará la garantía.**
- A fin de garantizar la seguridad, no intentar ensamblar este producto sin seguir cuidadosamente las instrucciones.
- Consultar todos los códigos de construcción locales para verificar si la caseta requiere un permiso de construcción.
- Verificar que el concreto esté nivelado completamente antes de ensamblar la caseta.
- Tener en cuenta que las piezas de plástico pueden dañarse si los tornillos se aprietan de más. A fin de evitar daños, lo exhortamos a que use un taladro con función de torque bajo. También puede usarse un desatornillador Phillips no. 2.
- Se necesitan tres adultos para el ensamble.
- Todos los que participen en el proceso de ensamble debe usar anteojos de seguridad durante todo el ensamble.
- Si se usa una escalera durante el ensamblado, es preciso tener cuidado.
-  En áreas de nevadas fuertes, recomendamos retirar la nieve del techo. Quitar la nieve del tejado cuando la profundidad de ella es igual a la longitud de la mano.
- No usar ni guardar objetos calientes cerca del producto.
- El ensamblaje correcto y completo son esenciales para reducir el riesgo de accidente o lesión.
- Al perforar metal, tenga cuidado las rebabas, virutas y otros bordes afilados.
- Durante y después del ensamblaje, no deslizar ni levantar la caseta por empujar en el tejado. Mover la caseta por empujar los paneles murales angulares solamente.
- Lo exhortamos a anclar la caseta al terminar el ensamble. La última sección, *Anclaje de la caseta*, en este manual muestra el herraje necesaria para terminar el anclaje. Se encuentra el herraje en la ferretería local.
- **La mayoría de las lesiones suceden a causa del mal uso y/o por no seguir las instrucciones. Tener precaución al usar este producto.**

## PLATFORM CONSTRUCTION / CONSTRUCTION DE LA PLATE-FORME / CONSTRUCCIÓN DE LA PLATAFORMA



• You must provide a platform on which to assemble your shed. Proper building permit documentation may be required in your neighborhood. Consult all local building codes prior to assembling the shed. Before beginning assembly, you must pour or construct a platform. There are two types:

- **Concrete**
- **Wood Frame**

Select the type, but know the surface must be leveled and flat before installation. If the surface is not properly leveled and flat, the shed will not assemble correctly. Proper surface leveling will save you time in the long run, so please do not ignore this step.

**We recommend a Concrete platform. It will be the most durable and long-lasting choice. The platform you choose must be built above ground in order to avoid water pooling inside the shed. All lumber must be rated for outdoor use!**



• Il faut construire une plate-forme pour l'abri. Il est possible que le quartier exige une documentation visant les permis de construire. Consulter tous les codes du bâtiment locaux, ainsi que les décrets des villes et comtés, pour vérifier que la construction de l'abri extérieur n'exige pas un permis de construire. Avant de commencer l'assemblage, il faut couler ou construire une plate-forme. Il y a deux types :

- **Béton**
- **Cadre à bois**

Sélectionner le type, mais savoir que la surface d'installation doit être de niveau et plate. Si la surface n'est pas correctement de niveau et plate, l'assemblage de l'abri ne se fera pas correctement. Le nivellement de la surface gagnera du temps sur le long terme; donc, ne pas négliger pas cette étape. **Nous recommandons une plate-forme en béton. Ce choix sera le plus durable. La plate-forme choisie doit être construite au-dessus du sol afin d'éviter l'accumulation d'eau à l'intérieur de l'abri. Tous le bois d'oeuvre doit être approuvé pour l'usage à l'extérieur !**



• Es preciso construir una plataforma sobre la cual usted debe ensamblar su caseta. Puede suceder que en su vecindario se requiera la documentación apropiada de un permiso de construcción. Consulte todos los códigos locales de construcción y los reglamentos de la ciudad y el municipio para asegurarse de que la construcción de la caseta no requiere un permiso de construcción. Antes de comenzar el ensamble, es necesario verter o construir una plataforma. Hay dos clases:

- **Concreto**
- **Armazón de madera**

Seleccionar la clase, mas saber que la superficie debe estar nivelada y plana antes de comenzar el ensamble. Si la superficie no está nivelada y plana de manera adecuada, la caseta no podrá armarse correctamente. La nivelación de la superficie le ahorrará tiempo de trabajo, por lo tanto, le pedimos que no ignore este paso. **Recomendamos una plataforma hecho de concreto. Será la elección más perdurable. La plataforma debe ser construida arriba del suelo para evitar el aflujo de agua dentro de la caseta. ¡Toda la madera debe estar clasificada para el uso externo!**

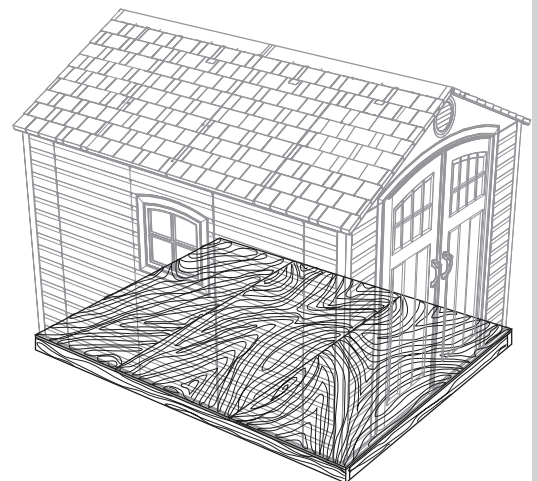
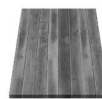
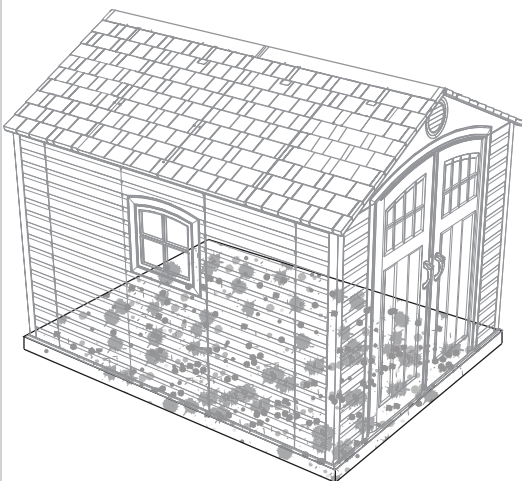

## ► SECTION 1 (CONTINUED) / SECTION 1 (SUITE) / SECCIÓN 1 (CONTINUACIÓN)

CONCRETE REQUIRED / BÉTON REQUIS / CONCRETO REQUERIDO



1 yd<sup>3</sup> (0,77 m<sup>3</sup>)

# 1.1

### CONCRETE PLATFORM / PLATE-FORME EN BÉTON / PLATAFORMA DE CONCRETO

- The concrete should be approximately 4" (10,2 cm) thick. The actual dimensions of the shed, at its widest and longest points, are 96" x 120" (2,44 m x 3,05 m). Ensure you select a site that will accommodate these measurements. **The floor dimensions are a bit smaller than those of the roof; therefore, you will need to build a level surface of 93 1/2" x 118 1/4" (2,38 m x 3,00 m).**
- Le béton doit être un épaisseur de 10,2 cm (4"). Les dimensions réelles de l'abri, aux points les plus large et long, sont 2,44 m x 3,05 m (96" x 120"). Veiller à sélectionner un site qui accommodera ces dimensions. **Les dimensions du plancher de votre abri sont plus petites que le toit; ensuite, il faut créer une surface nivelée de 2,38 m x 3,00 m (93 1/2" x 118 1/4").**
- El concreto debe tener, por lo menos, 10,2 cm (4") de espesor. Las dimensiones reales de la caseta, a sus puntos más ancho y largo, son 2,44 m x 3,05 m (96" x 120"). Asegurarse de seleccionar un sitio que acomodará estas medidas. **Las dimensiones del piso de la caseta son más pequeñas que el tejado; entonces, se necesita crear una superficie nivelada de 2,38 m x 3,00 m (93 1/2" x 118 1/4").**

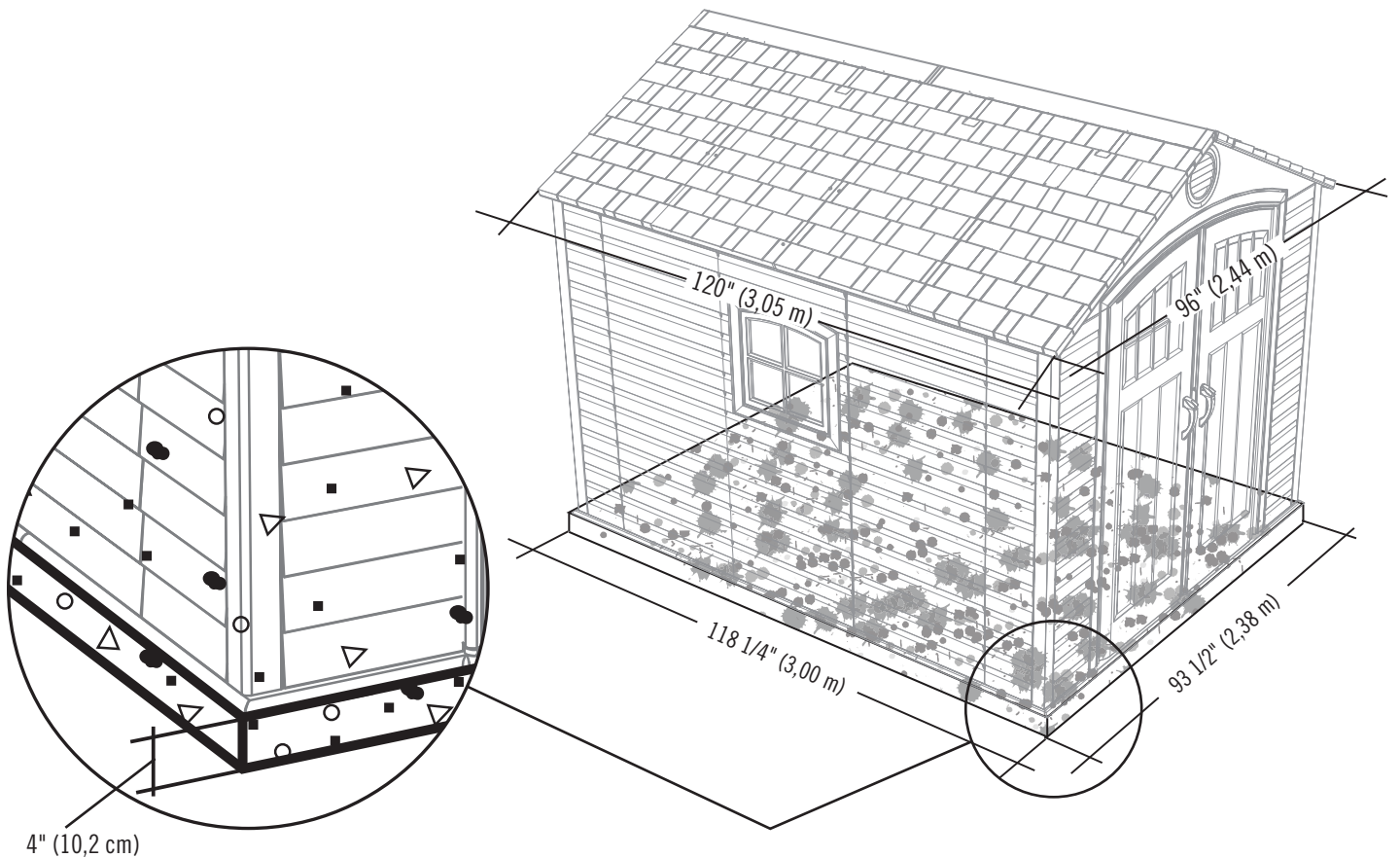

## ► SECTION 1 (CONTINUED) / SECTION 1 (SUITE) / SECCIÓN 1 (CONTINUACIÓN)

WOOD REQUIRED / BOIS REQUIS / MADERA REQUERIDA



# 1.2

WOOD PLATFORM / PLATE-FORME EN BOIS / PLATAFORMA DE MADERA

- **All lumber must be rated for outdoor use!** The actual dimensions of the shed, at its widest and longest points, are 96" x 120" (2,44 m x 3,05 m). Ensure you select a site that will accommodate these measurements. **The floor dimensions are a bit smaller than those of the roof; therefore, you will need to build a level surface of 93 1/2" x 118 1/4" (2,38 m x 3,00 m).**
- **Tous le bois d'oeuvre doit être approuvé pour l'usage à l'extérieur !** Les dimensions réelles de l'abri, aux points les plus large et long, sont 2,44 m x 3,05 m (96" x 120"). Veiller à sélectionner un site qui accommodera ces dimensions. **Les dimensions du plancher de votre abri sont plus petites que le toit; donc, il faut créer une surface nivelée de 2,38 m x 3,00 m (93 1/2" x 118 1/4").**
- **¡Toda la madera debe estar clasificada para el uso externo!** Las dimensiones reales de la caseta, a sus puntos más ancho y largo, son 2,44 m x 3,05 m (96" x 120"). Asegurarse de seleccionar un sitio que acomodará estas medidas. **Las dimensiones del piso de la caseta son más pequeñas que el tejado; por lo tanto, se necesita crear una superficie nivelada de 2,38 m x 3,00 m (93 1/2" x 118 1/4").**

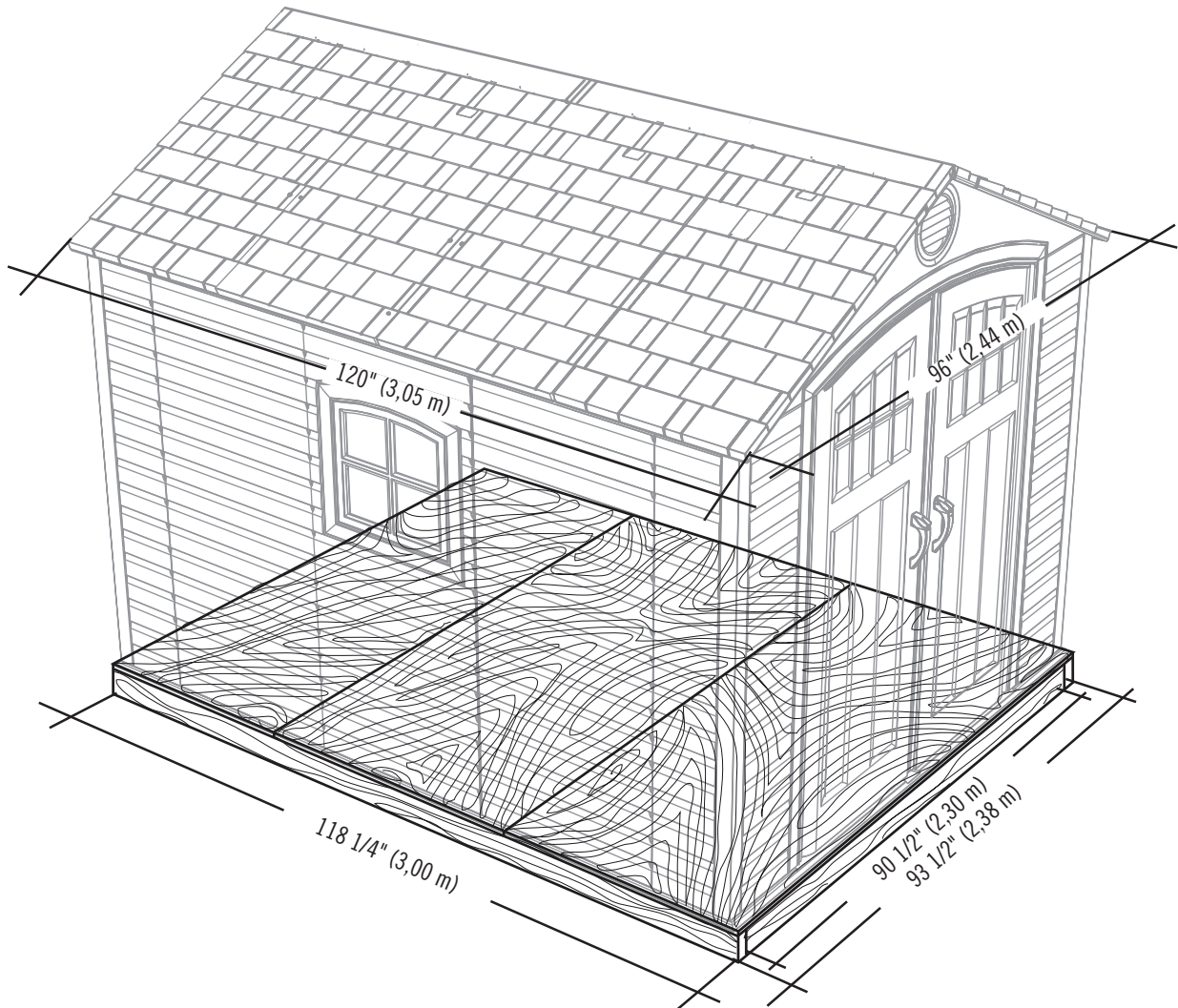



## ► SECTION 1 (CONTINUED) / SECTION 1 (SUITE) / SECCIÓN 1 (CONTINUACIÓN)

TOOLS, PARTS, AND HARDWARE REQUIRED / OUTILS, PIÈCES, ET QUINCAILLERIE REQUIS / INSTRUMENTAL, PIEZAS, Y HERRAJE REQUERIDOS

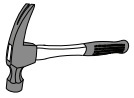

2" x 4" x 118 1/4" (5,1 cm x 10,2 cm x 3,00 m) (x2)



2" x 4" x 90 1/2" (5,1 cm x 10,2 cm x 2,30 m) (x9)

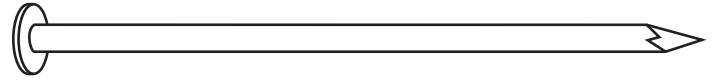

16d 3 1/2" (16d x 8,89 cm) (x36)

### 1.2.1

#### WOOD PLATFORM / PLATAFORMA DE MADERA / PLATE-FORME EN BOIS

- Ensure all lumber is treated and approved for outdoor use. Build frame to 93 1/2" x 118 1/4" (2,38 m x 3,00 m) (**outside dimensions**).
- Vérifier que le bois d'œuvre à été traité et approuvé pour l'utilisation à l'extérieur. Construire un cadre de 2,38 m x 3,00 m (93 1/2" x 118 1/4") (**dimensions extérieures**).
- Asegurar que use madera tratada y aprobada para el uso externo. Construir el armazón a 2,38 m x 3,00 m (93 1/2" x 118 1/4") (**dimensiones exteriores**).

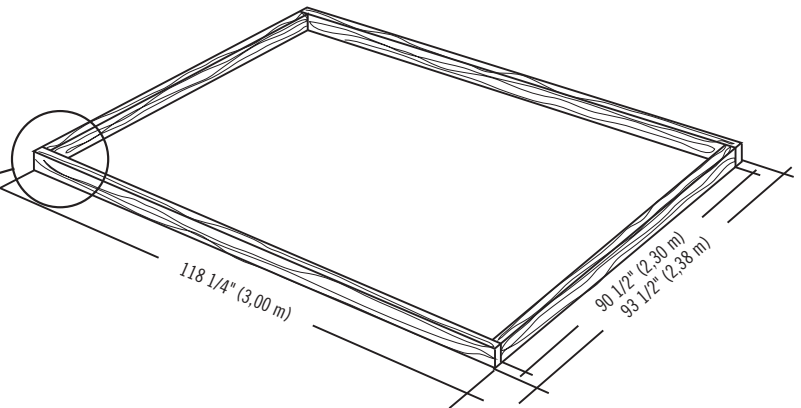
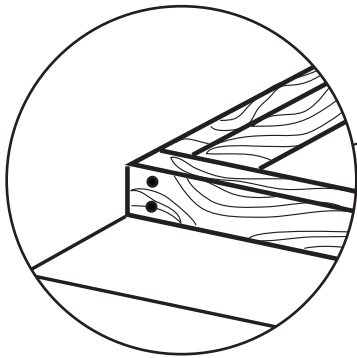

### 1.2.2

- To ensure studs are in the correct location for nailing plywood in the next step, start measuring from the corner 16" (40,1 cm), and then measure from center to center.
- Pour être sûr d'avoir assez de montant pour clouer le contreplaqué dans la prochaine étape, commencer à mesurer à partir de cette montant 40,1 cm (16") vers le centre du deuxième montant. Ensuite, mesurer de centre à centre pour les montants restants.
- Para asegurarse que los montantes están en las ubicaciones correctas para el contrachapado en el paso siguiente, comenzar a medir desde el borde del montante hasta el centro del próximo montante 40,1 cm (16"). Luego, tomar la medida de centro a centro en los montantes restantes.

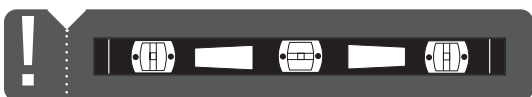
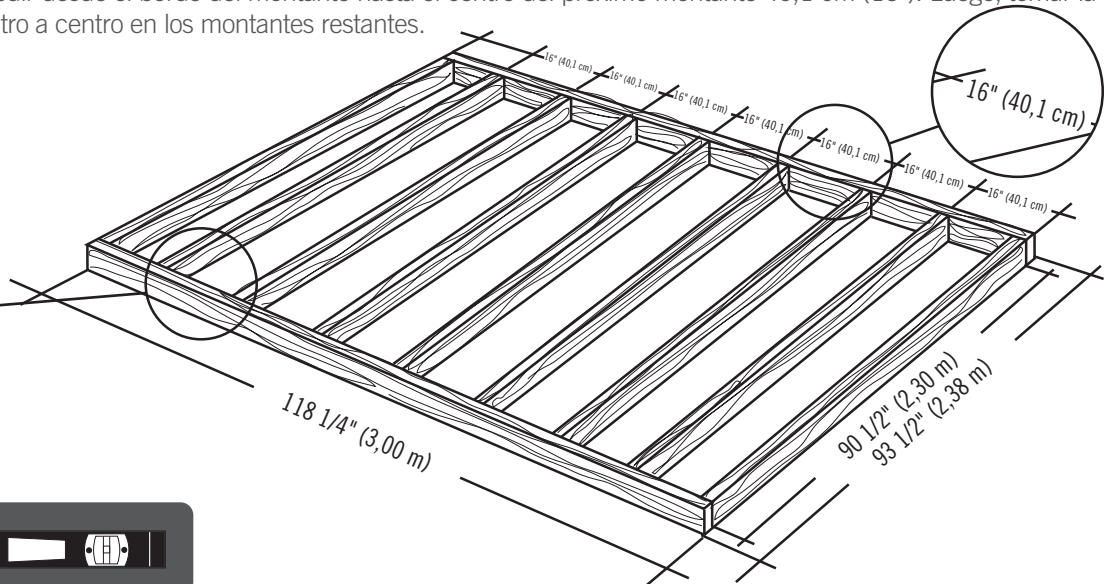
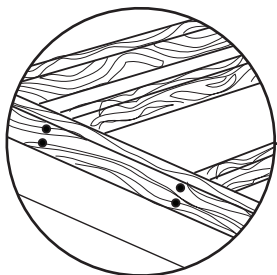
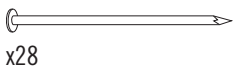



## ► SECTION 1 (CONTINUED) / SECTION 1 (SUITE) / SECCIÓN 1 (CONTINUACIÓN)

TOOLS, PARTS, AND HARDWARE REQUIRED / OUTILS, PIÈCES, ET QUINCAILLERIE REQUIS / INSTRUMENTAL, PIEZAS, Y HERRAJE REQUERIDOS

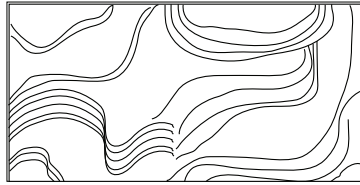
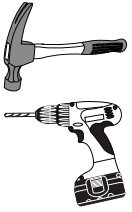

48" x 93 1/2" x 3/4"  
(1,22 m x 2,38 m x 19,1 mm) (x2)



22 1/4" x 93 1/2" x 3/4"  
(57 cm x 2,38 m x 19,1 mm) (x1)

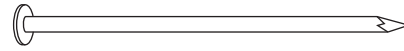

8d 2" (8d 5,08 cm) (x66)

### 1.2.3

- Square the frame, measuring from corner to corner. **Measurement A & B should be about the same length.**
- Carrer le cadre en mesurant d'angle à angle. **La mesure "A" et "B" doivent être à peu près la même longueur.**
- Cuadrar el armazón midiendo de esquina a esquina. **La medida "A" y "B" deben ser aproximadamente el mismo largo.**

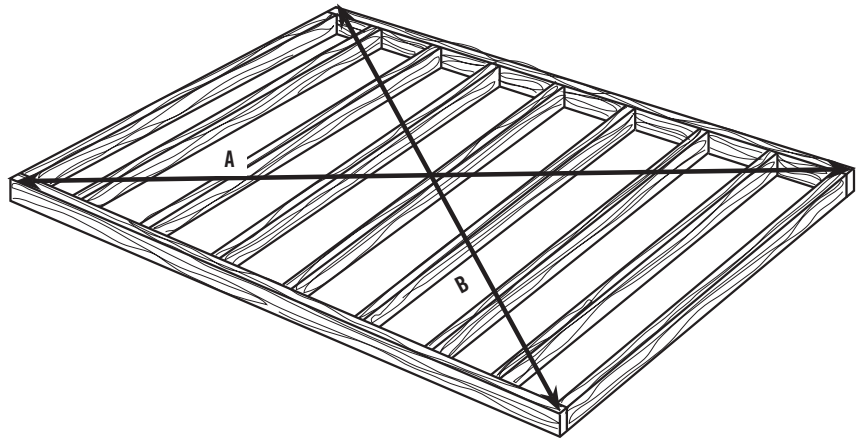

! A = B

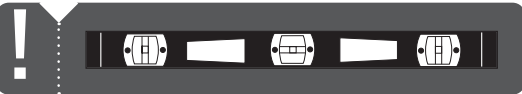

### 1.2.4

- Using nails, fasten the plywood to the frame. Then, drill 5/16" holes for drainage.
- En utilisant des clous, attacher bien le contreplaqué au cadre. Ensuite, percer des trous de 8 mm pour le drainage.
- Usando unos clavos, sujetar el contrachapado al armazón. Entonces, taladrar agujeros de 8 mm para el drenaje.

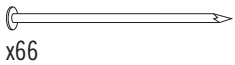

x66

22 1/4" x 93 1/2" x 3/4"  
(57 cm x 2,38 m x 19,1 mm)

48" x 93 1/2" x 3/4"  
(1,22 cm x 2,38 m x 19,1 mm)

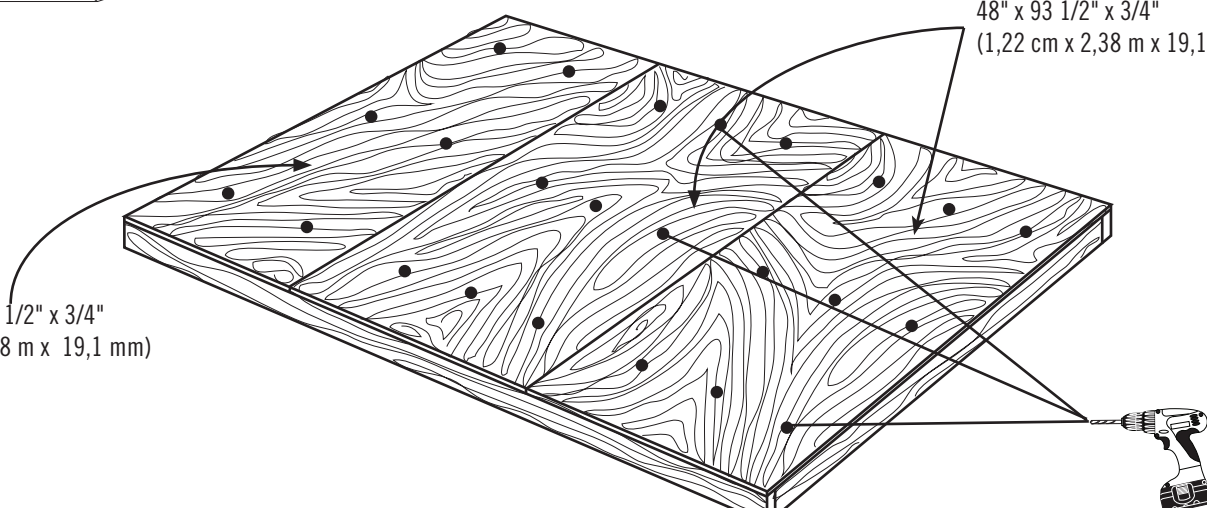

Drainage Holes  
Agujeros para canalización  
Trous de drainage

x24!

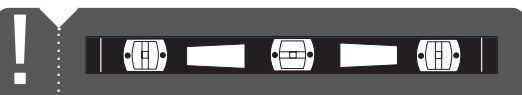

# 2

## TRUSS ASSEMBLY / ASSEMBLAGE DES FERMES / ENSAMBLE DE LAS CERCHAS



### HARDWARE REQUIRED / QUINCAILLERIE REQUISE / HERRAJE REQUERIDO

Hardware Bag / Sac de quincaillerie / Bolsa de herraje

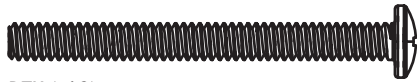

DTK (x12)



ADJ (x6)

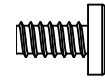

ADY (x12)



ADK (x24)

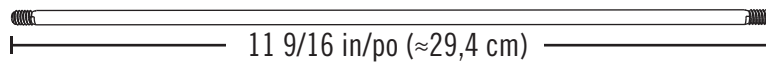

11 9/16 in/po (≈29,4 cm)

ADH (x3)

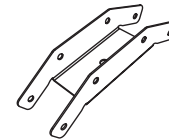

AIP (x3)



### PARTS REQUIRED / PIÈCES REQUISES / PIEZAS REQUERIDAS

Metal Parts / Pièces en métal / Piezas de metal



50 9/16 in/po (≈1,28 m)

DSR (x6)

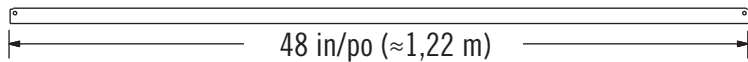

48 in/po (≈1,22 m)

AFG (x3)

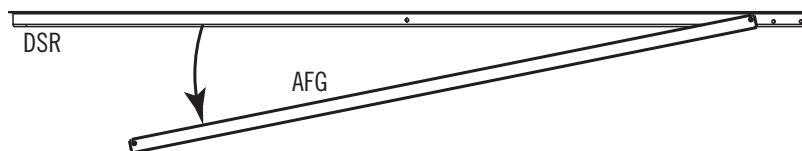
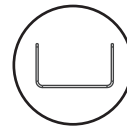

- Sometimes during shipping, the Truss Brace (AFG) slides over the back of the Truss Gutter Channel (DSR). The two pieces are the same color. If you think you're missing a Truss Brace, check to see if it is stuck to the back of the Truss Gutter Channel, and separate the two.
- Durant le transport, parfois le support de ferme (AFG) glisse par-dessus l'arrière du canal de ferme (DSR). Les deux pièces sont du même colour. Si vous pensez que vous n'avez pas de support de ferme, vérifiez s'il y a un support de ferme adhérent à l'arrière du canal de ferme, et séparez les deux.
- Durante el transporte, a veces el soporte de cercha (AFG) deslice sobre el dorso del canalón de cercha (DSR). Las dos piezas son de la misma color. Si piensa que le falta un soporte de cercha, verifique si haya un soporte pegado al dorso del canalón de cercha, y separe las dos.



### TOOLS REQUIRED / OUTILS REQUIS / INSTRUMENTAL REQUERIDO



7/16 in/po (≈11 mm) (x2)



3/8 in/po (≈10 mm)

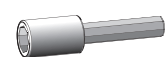

3/8 in/po (≈10 mm)

## ► SECTION 2 (CONTINUED) / SECTION 2 (SUITE) / SECCIÓN 2 (CONTINUACIÓN)

TOOLS AND HARDWARE REQUIRED / OUTILS ET QUINCAILLERIE REQUIS / INSTRUMENTAL Y HERRAJE REQUERIDOS

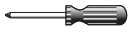

3/8 in/po  
(≈10 mm)



DTK (x12)



ADK (x12)



- If you have trouble with this section, follow the code below to view a how-to video on this section.
- En cas de problèmes avec l'assemblage de cette section, suivre le code en bas pour voir un vidéo sur l'assemblage dans cette section.
- En caso de problemas con el ensamble en esta sección, seguir el código debajo para ver un video sobre el ensamble en esta sección.

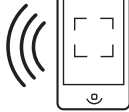

<http://go.lifetime.com/8trussassembly>

### 2.2

- Attach the **Connector** using the hardware indicated. **Do not overtighten the Cap Nuts.**
- Attacher le **raccord (AIP)** à l'aide de la quincaillerie indiquée. **Ne pas serrer excessivement les écrous borgnes.**
- Sujetar el **connector (AIP)** usando el herraje indicado. **No apretar demasiado las tuercas ciegas.**

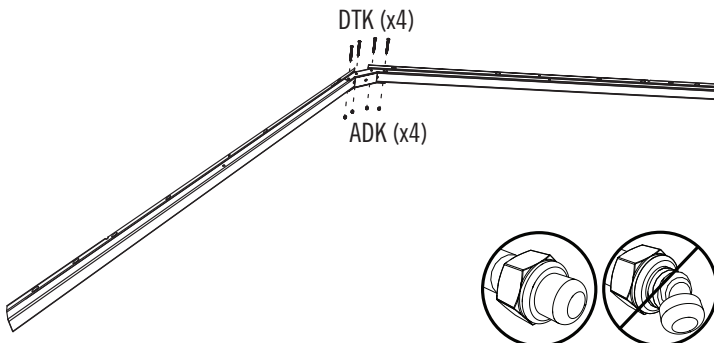

### 2.1

- Slide a **Connector (AIP)** onto the ends of two **Truss Gutter Channels (DSR)** as shown.
- Faire glisser un **raccord (AIP)** sur les extrémités des **canaux de gouttière (DSR)** comme illustré.
- Deslizar un **connector (AIP)** en los extremos de los **canalones de cercha (DRS)** como se muestra.

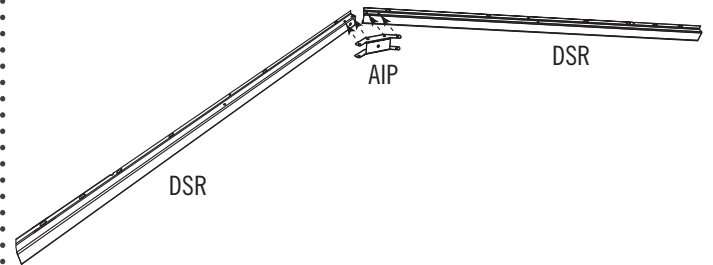

### 2.3

- Slide a **Large Truss Brace (AFG)** onto the Truss Gutter Channels as shown, and align the holes.
- Faire glisser un **support de ferme (AFG)** sur les canaux de gouttière comme illustré, et aligner les trous.
- Deslizar un **soporte de cercha (AFG)** sobre los canalones de la cercha como se muestra, y alinear los agujeros.

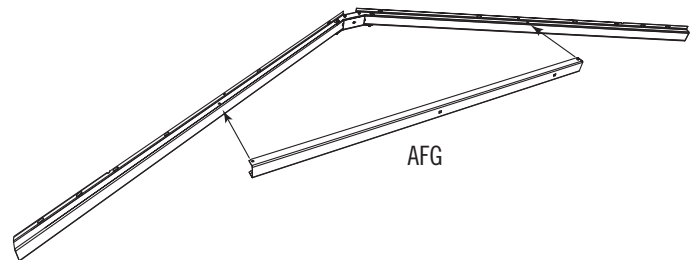

## ► SECTION 2 (CONTINUED) / SECTION 2 (SUITE) / SECCIÓN 2 (CONTINUACIÓN)

TOOLS AND HARDWARE REQUIRED / OUTILS ET QUINCAILLERIE REQUIS / INSTRUMENTAL Y HERRAJE REQUERIDOS



3/8 in/po  
(≈10 mm)

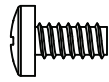

ADY (x12)



ADK (x12)

### 2.4

- Attach the Large Truss Brace using the hardware included. **Do not overtighten the Cap Nuts.**
- Attacher le support de ferme à l'aide de la quincaillerie incluse. **Ne pas serrer excessivement les écrous borgnes.**
- Sujetar el soporte de cercha usando el herraje incluido. **No apretar demasiado las tuercas ciegas.**

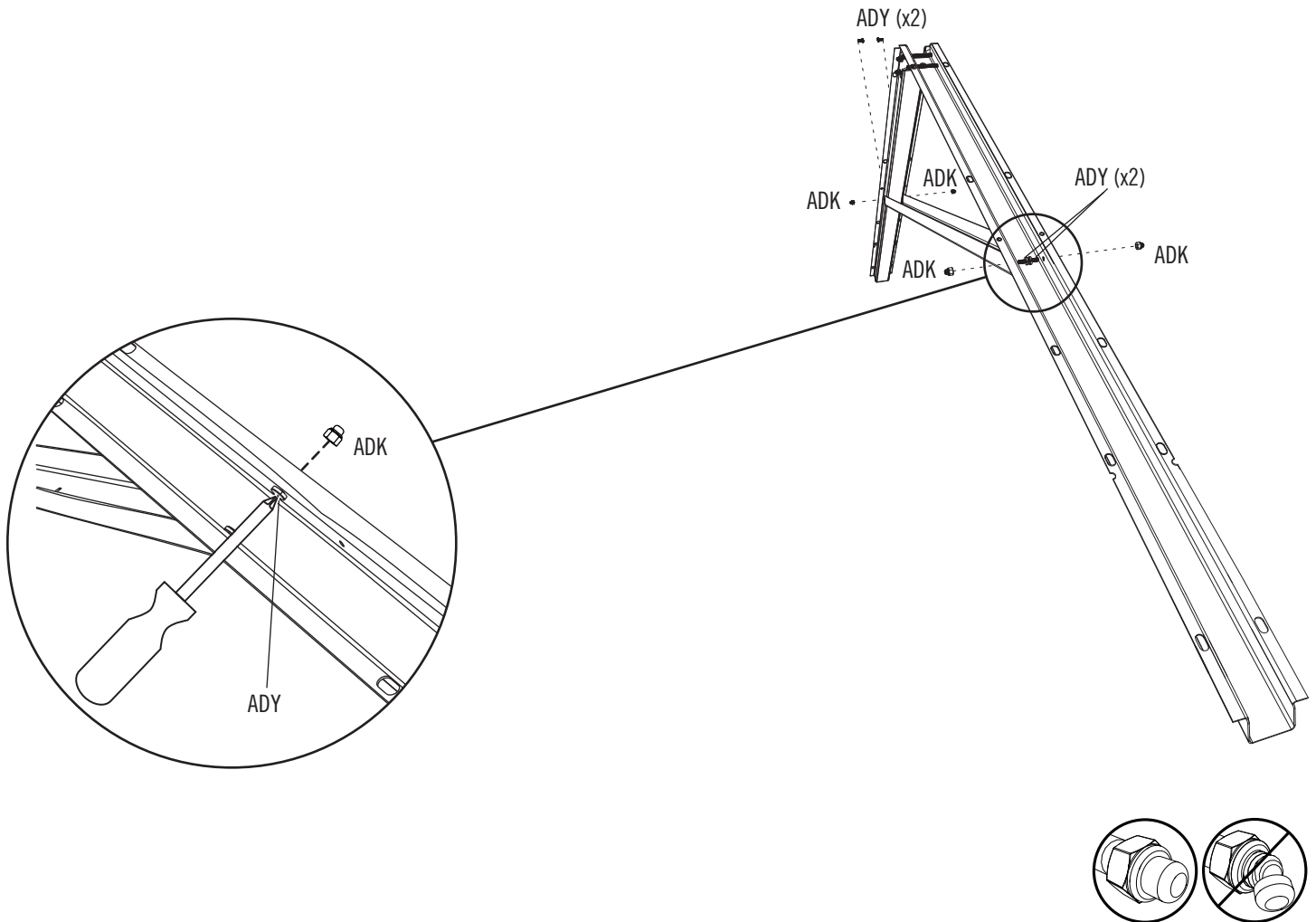

## ► SECTION 2 (CONTINUED) / SECTION 2 (SUITE) / SECCIÓN 2 (CONTINUACIÓN)

TOOLS AND HARDWARE REQUIRED / OUTILS ET QUINCAILLERIE REQUIS / INSTRUMENTAL Y HERRAJE REQUERIDOS



7/16 in/po (x2)  
(≈11 mm) (x2)



ADJ (x6)

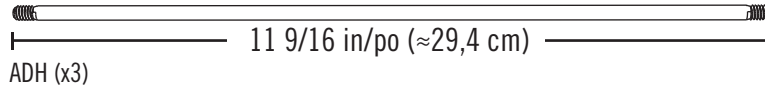

ADH (x3)

# 2.5

- Slide a **Truss Rod (ADH)** through the holes in the Truss Brace and Connector. Secure with two **Cap Nuts (ADJ)**. **Do not overtighten the Nuts.**
- Faire glisser une **tige (ADH)** à travers les trous dans le support et le raccord. L'attacher bien à l'aide de deux **écrous borgnes (ADJ)**. **Ne pas serrer excessivement les écrous.**
- Deslizar una **varilla (ADH)** a través de los agujeros en el soporte y el conector. Sujetarla con dos **tuercas ciegas (ADJ)**. **No apretar demasiado las tuercas.**

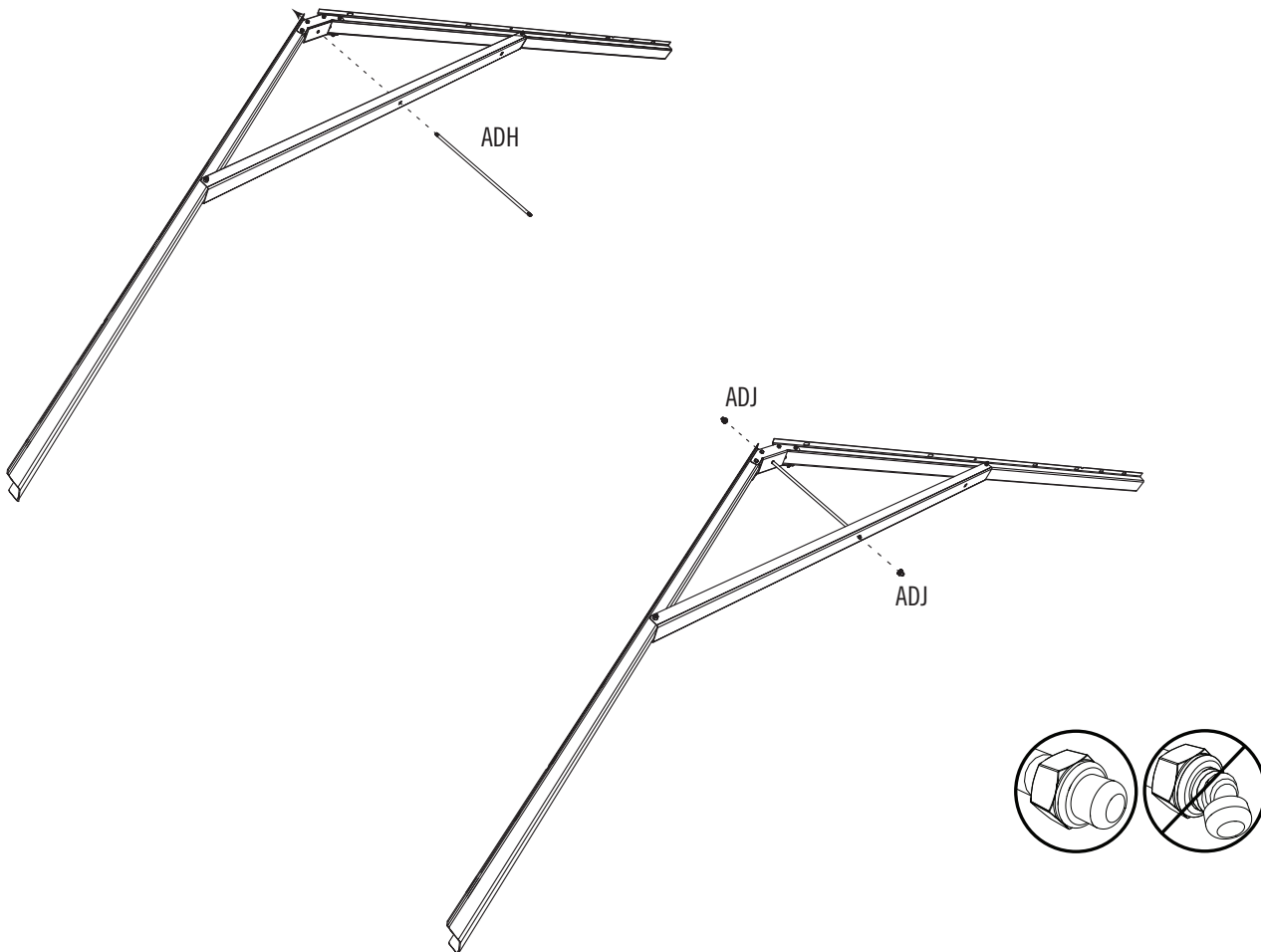



## ► SECTION 2 (CONTINUED) / SECTION 2 (SUITE) / SECCIÓN 2 (CONTINUACIÓN)

TOOLS AND HARDWARE REQUIRED / OUTILS ET QUINCAILLERIE REQUIS / INSTRUMENTAL Y HERRAJE REQUERIDOS



### 2.6

- Repeat steps 2.1–2.5 two times.
- Répéter les étapes 2.1 – 2.5 deux fois.
- Repetir los pasos 2.1–2.5 dos veces.

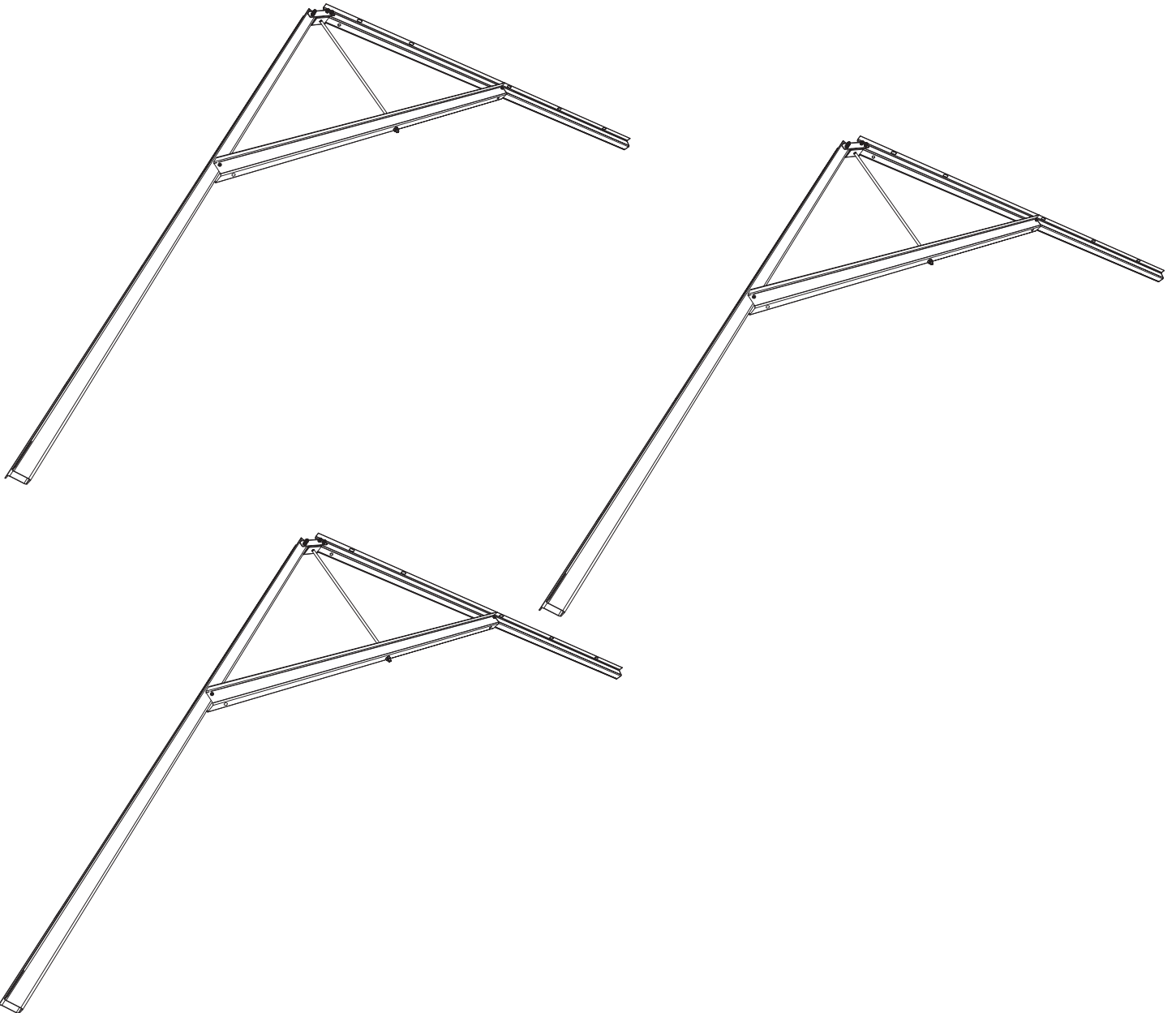

# 3

## GABLE ASSEMBLY / ASSEMBLAGE DES PIGNONS / ENSAMBLAJE DE LAS FACHADAS



### HARDWARE REQUIRED / QUINCAILLERIE REQUISE / HERRAJE REQUERIDO

Hardware Bag / Sac de quincaillerie / Bolsa de herraje

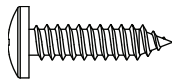

ADW (x10)

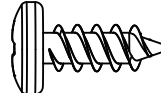

ADZ (x6)



ADK (x2)

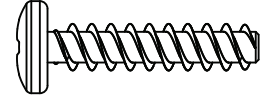

ADV (x6)



AHS (x2)

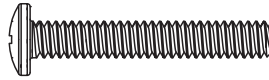

EYR (x2)



CXK (x2)



AEE (x14)

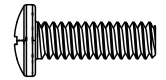

EYQ (x2)

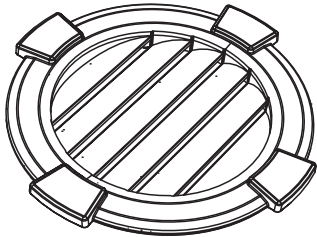

ENH (x2)

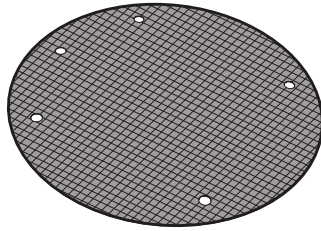

AIQ (x2)



### PARTS REQUIRED / PIÈCES REQUISES / PIEZAS REQUERIDAS

Metal Part / Pièce en métal / Pieza de metal



EYS (x1)

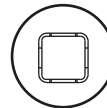

Plastic Parts / Pièces en plastique / Piezas de plástico

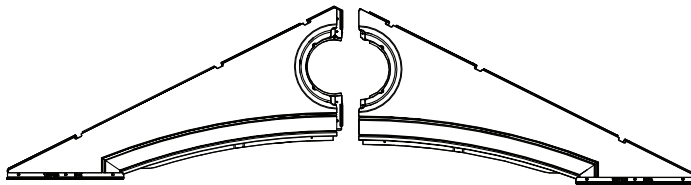

EVZ (x1)

EWA (x1)

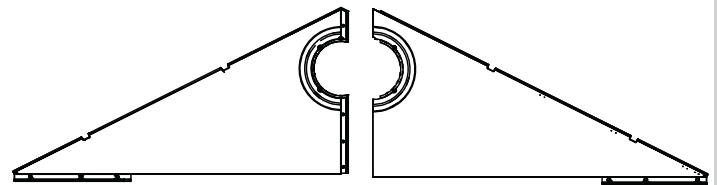

AGI (x1)

AGH (x1)



### TOOLS REQUIRED / OUTILS REQUIS / INSTRUMENTAL REQUERIDO



3/8" (≈10 mm)

## ► SECTION 3 (CONTINUED) / SECTION 3 (SUITE) / SECCIÓN 3 (CONTINUACIÓN)

TOOLS AND HARDWARE REQUIRED / OUTILS ET QUINCAILLERIE REQUIS / INSTRUMENTAL Y HERRAJE REQUERIDOS

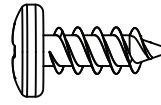

ADZ (x4)

### 3.1

- Align the holes in the **Left (AGH)** and **Right (AGI)** Rear Gable Halves.
- Aligner les trous dans les **pignons gauche (AGH)** et **droite (AGI)**.
- Alinear los agujeros en las **fachadas traseras izquierda (AGH)** y **derecha (AGI)**.

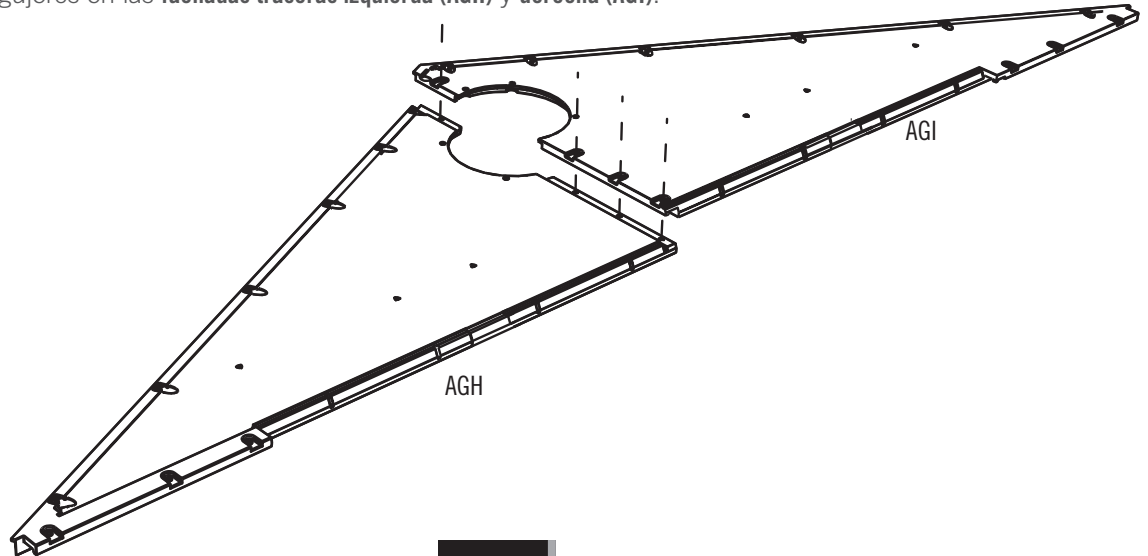

### 3.2

- Secure the two Gable Halves with four (4) **Screws (ADZ)**.
- Attacher l'un à l'autre à l'aide de quatre (4) **vis (ADZ)**.
- Sujetar el uno al otro usando cuatro (4) **tornillos (ADZ)**.

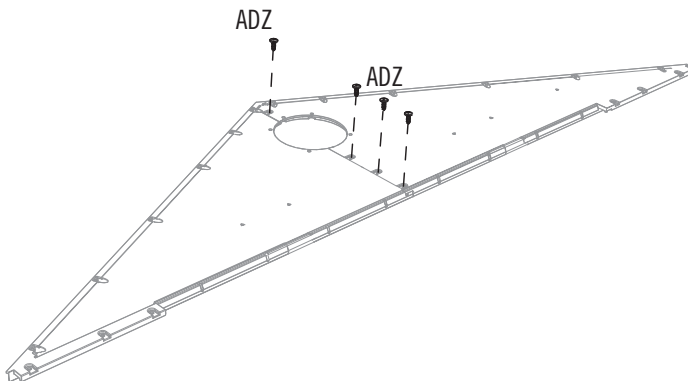

### 3.3

- Place the **Screen (AIQ)** over the **Vent (ENH)**, and align the five holes in the Vent with those in the Gable.
- Mettre la **moustiquaire (AIQ)** sur l'**évent (ENH)**, et aligner les cinq trous dans l'évent avec ceux du pignon.
- Colocar el **mosquitero (AIQ)** sobre la **rejilla de ventilación (ENH)**, y alinear los agujeros en la rejilla con los de la fachada.

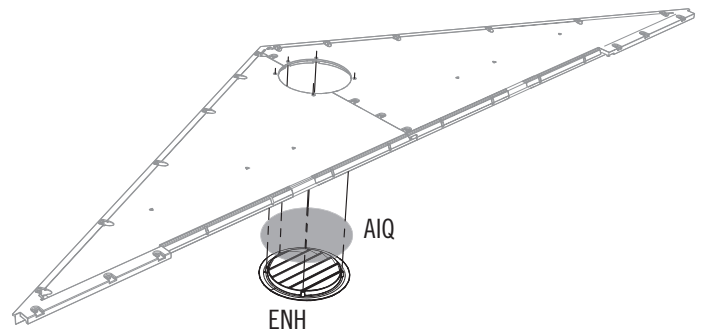

## ► SECTION 3 (CONTINUED) / SECTION 3 (SUITE) / SECCIÓN 3 (CONTINUACIÓN)

TOOLS AND HARDWARE REQUIRED / OUTILS ET QUINCAILLERIE REQUIS / INSTRUMENTAL Y HERRAJE REQUERIDOS



3/8"  
(≈10 mm)

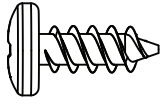

ADZ (x2)

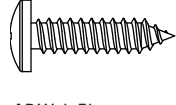

ADW (x5)

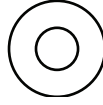

AEE (x7)

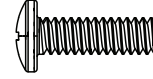

EYQ (x2)



CXK (x2)

### 3.4

- Secure with the hardware included.
- Attacher-les en utilisant la quincaillerie incluse.
- Sujetar los unos a los otros usando el herraje incluido.

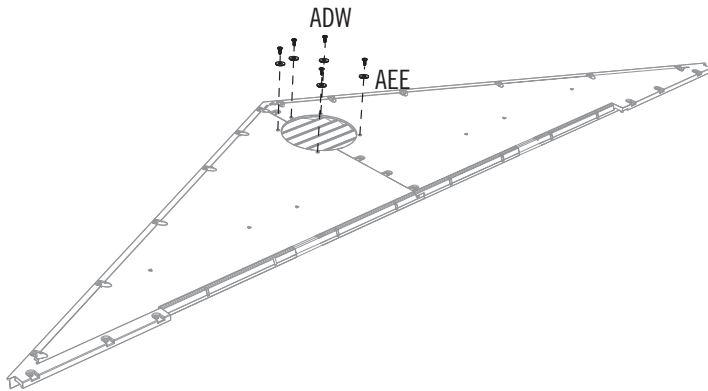

### 3.5

- Align the holes in the **left (EVZ)** and **right (EWA)** entry gable halves.
- Aligner les trous dans les **demis pignons d'entrée gauche (EVZ)** et **droit (EWA)**.
- Alinear los agujeros en las **mitades de la fachada trasera izquierda (EVZ)** y **derecha (EWA)**.

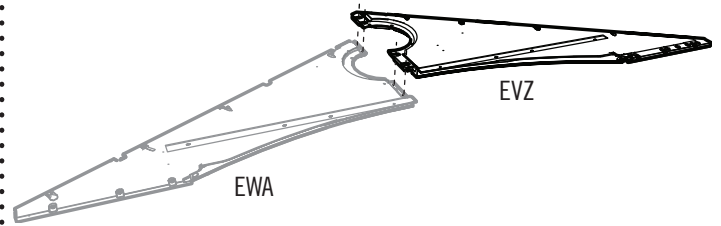

### 3.6

- Secure with the hardware included. **Do not overtighten.**
- Fixer à l'aide de la quincaillerie incluse. **Ne pas trop serrer.**
- Sujetar con el herraje incluido. **No apretar demasiado.**

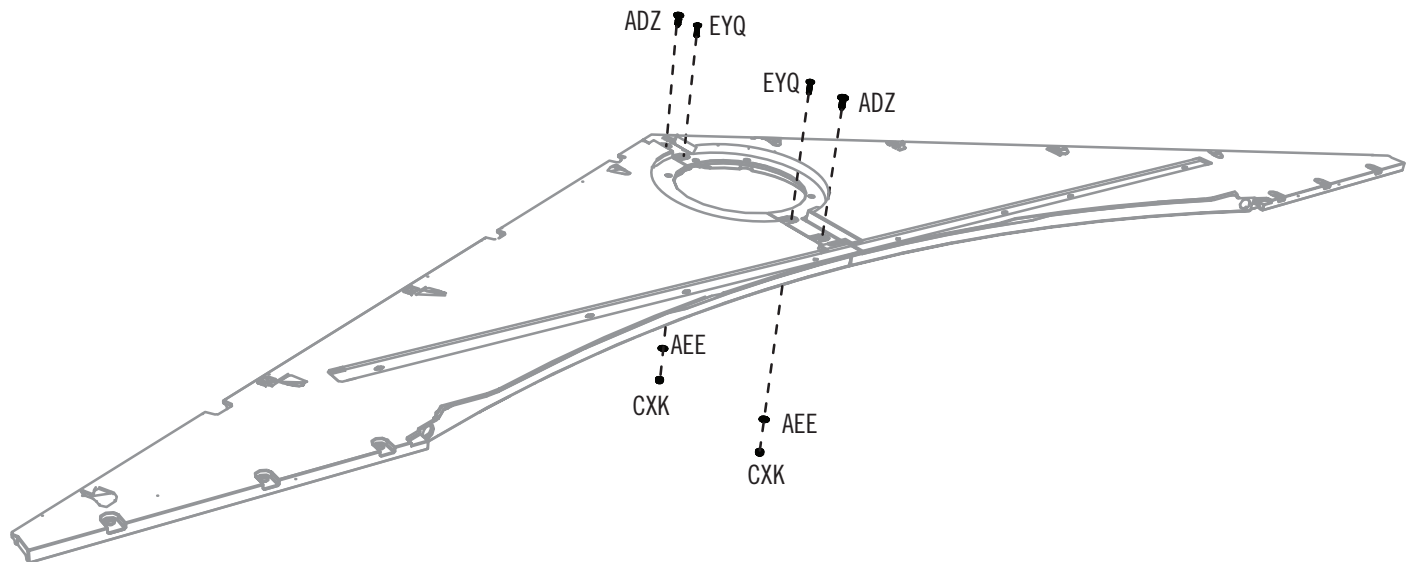

### ► SECTION 3 (CONTINUED) / SECTION 3 (SUITE) / SECCIÓN 3 (CONTINUACIÓN)

TOOLS AND HARDWARE REQUIRED / OUTILS ET QUINCAILLERIE REQUIS / INSTRUMENTAL Y HERRAJE REQUERIDOS

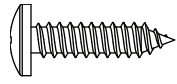

ADW (x5)

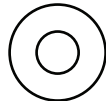

AEE (x5)

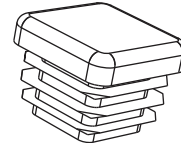

AHS (x2)

## 3.7

- Repeat steps 3.3–3.4 for the entry gable.
- Répéter les étapes 3.3 – 3.4 pour le pignon d'entrée.
- Repetir los pasos 3.3–3.4 para la fachada de entrada.

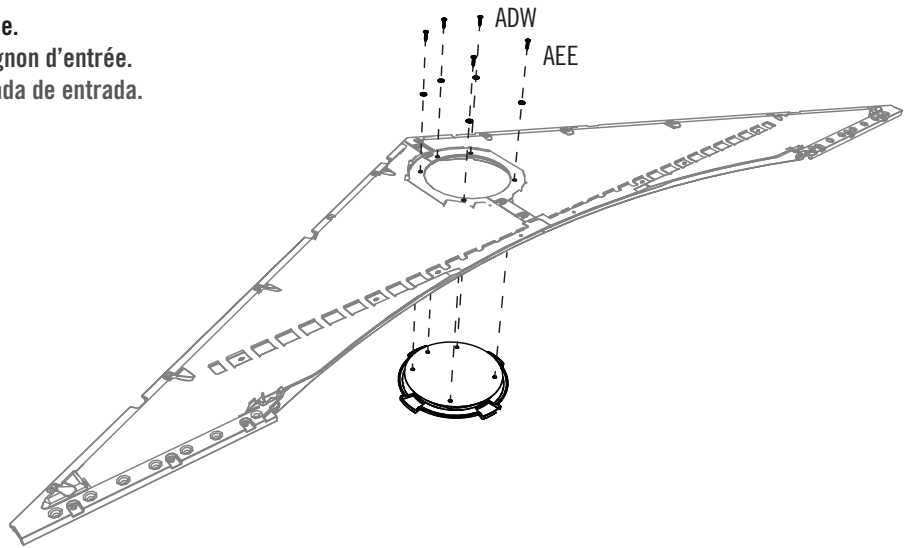
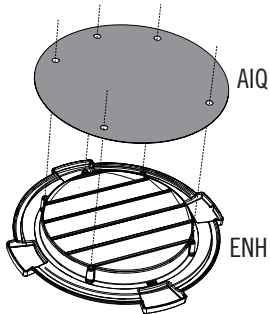

## 3.8

- Insert an **end cap (AHS)** into each end of the **header (EYS)**.
- Insérer un **capuchon (AHS)** dans chaque extrémité du **linteau (EYS)**.
- Insertar un **tapón (AHS)** en cada extremo del **dintel (EYS)**.

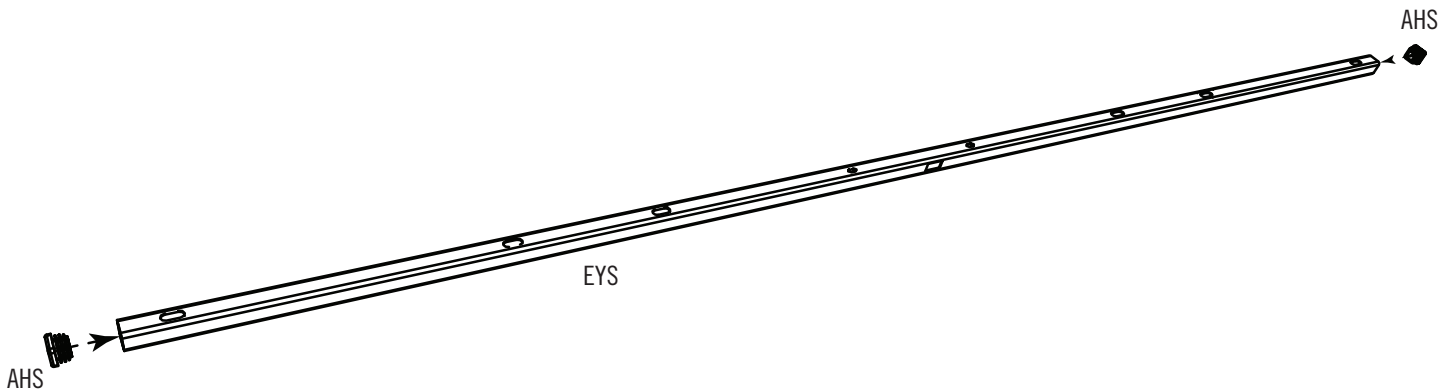



## ► SECTION 3 (CONTINUED) / SECTION 3 (SUITE) / SECCIÓN 3 (CONTINUACIÓN)

TOOLS AND HARDWARE REQUIRED / OUTILS ET QUINCAILLERIE REQUIS / INSTRUMENTAL Y HERRAJE REQUERIDOS



3/8"  
(≈10 mm)

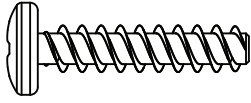

ADV (x6)

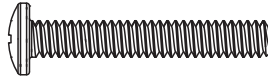

EYR (x2)

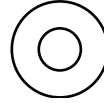

AEE (x2)



ADK (x2)

### 3.9

- Align the holes in the header with those in the gable.
- Aligner les trous dans le linteau avec ceux dans le pignon.
- Alinear los agujeros en el dintel con los de la fachada.



*Note: the flat holes face away from the gable.*  
*Remarque : Les trous plats font face de l'autre côté du pignon.*  
*Nota: Los agujeros lisos miran en contra de la fachada.*

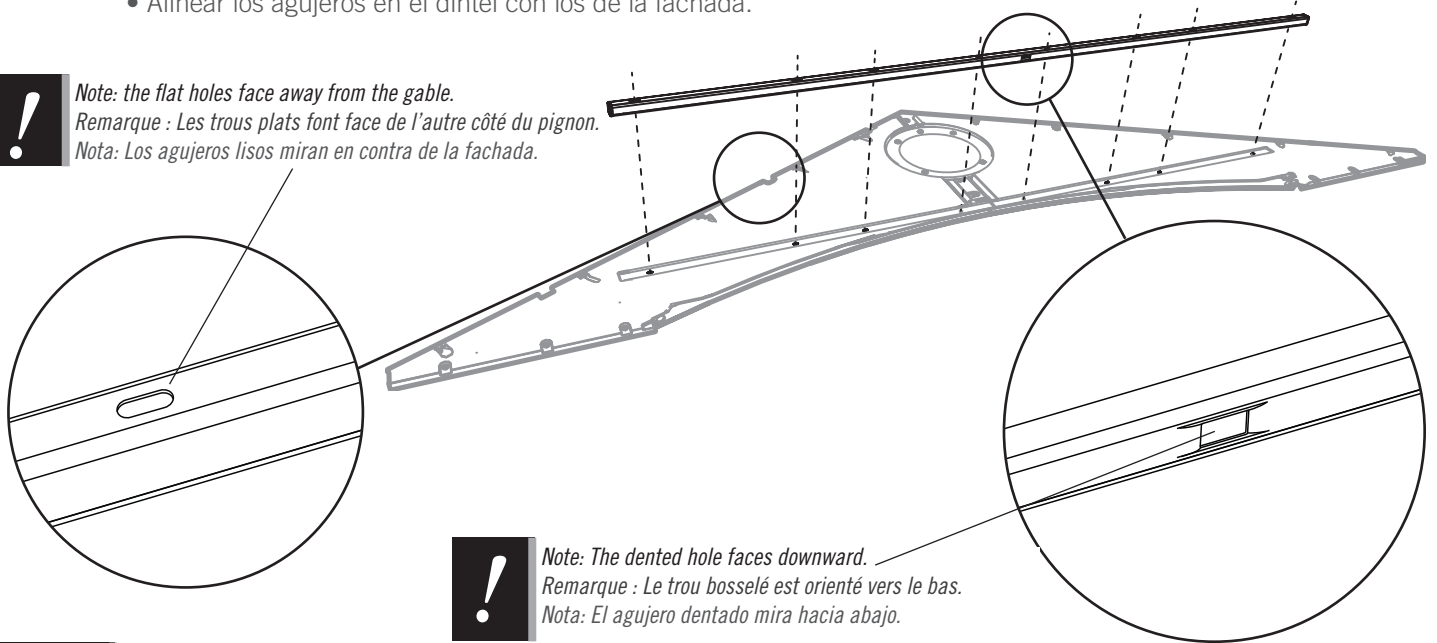

*Note: The dented hole faces downward.*  
*Remarque : Le trou bosselé est orienté vers le bas.*  
*Nota: El agujero dentado mira hacia abajo.*

### 3.10

- Secure with two (2) screws (EYR), two (2) washers (AEE), and two (2) nuts (ADK). **Do not overtighten.**
- Le fixer à l'aide de deux (2) vis (EYR), deux (2) rondelles (AEE), et deux écrous (ADK). **Ne pas trop serrer.**
- Sujetarlo con dos (2) tornillos (EYR), dos (2) rondanas (AEE), y dos tuercas (ADK). **No apretar demasiado.**

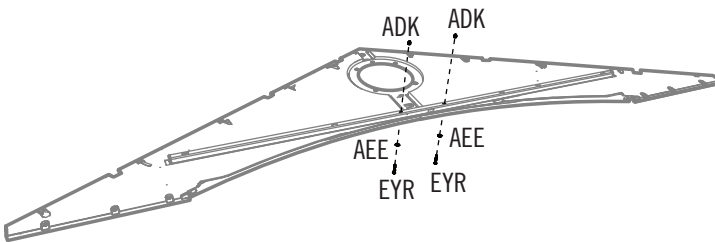

### 3.11

- Secure with six (6) more screws (ADV).
- Le fixer à l'aide de six (6) vis (ADV) de plus.
- Sujetarlo con seis (6) más tornillos (ADV).

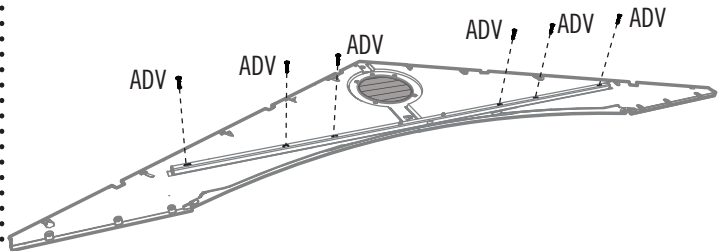

# 4

## LEFT DOOR ASSEMBLY / ASSEMBLAGE DE LA PORTE GAUCHE / ENSAMBLE DE LA PUERTA IZQUIERDA



### HARDWARE REQUIRED / QUINCAILLERIE REQUISE / HERRAJE REQUERIDO

Hardware Bag / Sac de quincaillerie / Bolsa de herraje

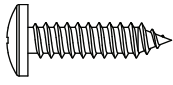

ADW (x1)

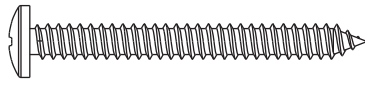

BYZ (x2)

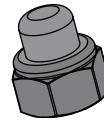

ADJ (x2)

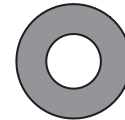

AEB (x2)

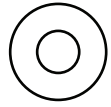

AEE (x3)

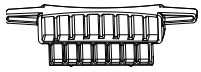

AHM (x2)

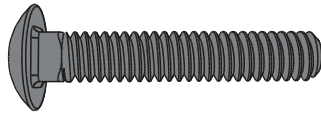

ACH (x2)

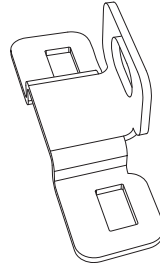

ECY (x1)

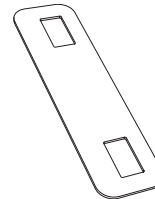

ECX (x1)

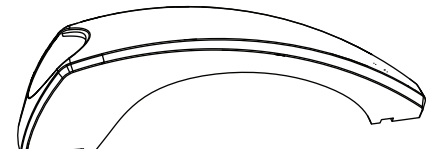

BYS (x1)



BYR (x1)



### PARTS REQUIRED / PIÈCES REQUISES / PIEZAS REQUERIDAS

Metal Parts / Pièces en métal / Piezas de metal

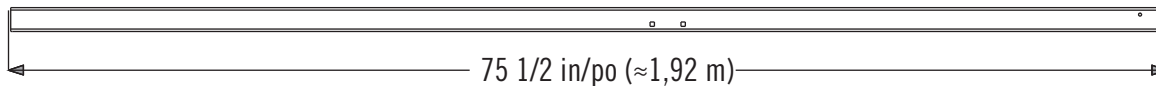

BLH (x1)

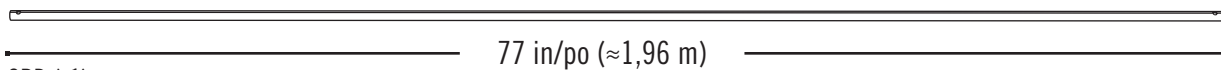
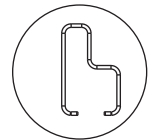

CRD (x1)



Plastic Parts / Pièces en plastique / Piezas de plástico

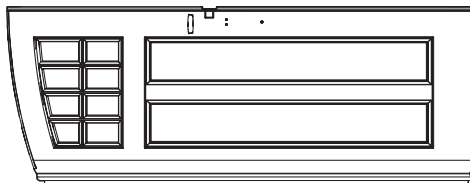

BDJ (x1)

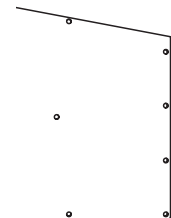

### TOOLS REQUIRED / OUTILS REQUIS / INSTRUMENTAL REQUERIDO



7/16 in/po  
(11 mm)

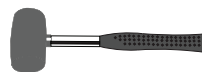

## ► SECTION 4 (CONTINUED) / SECTION 4 (SUITE) / SECCIÓN 4 (CONTINUACIÓN)

TOOLS AND PARTS REQUIRED / OUTILS ET QUINCAILLERIE REQUIS / INSTRUMENTAL Y HERRAJE REQUERIDOS

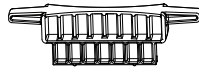

AHM (x2)

### 4.1

- Slide a **Hinge Tube (CRD)** down into the hole at the top of the **Left Door (BDJ)**.
- Faire glisser le **tube d'articulation (CRD)** dans le trou au bord supérieur de la **porte gauche (BDJ)**.
- Deslizar el **tubo de articulación (CRD)** en el agujero a la parte superior de la **puerta izquierda (BDJ)**.

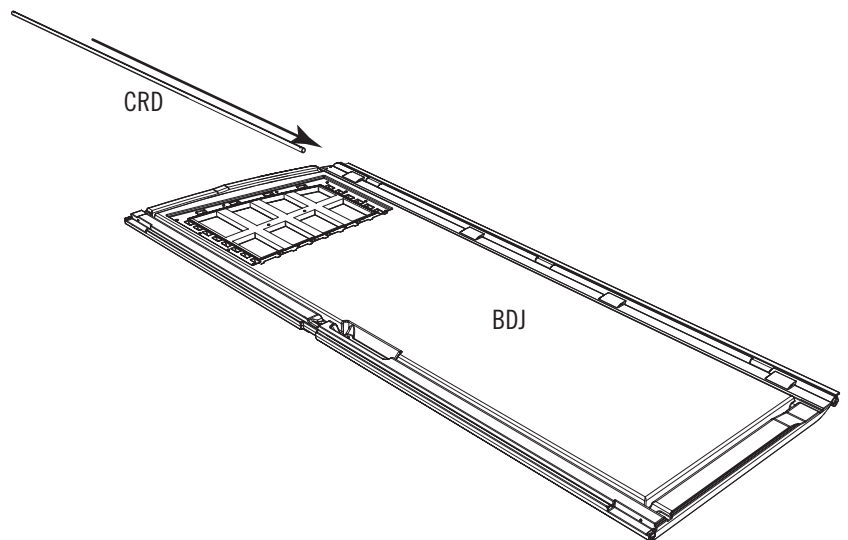

• **Door Channels (BLH)** are specifically designed to bow. This ensures a tight fit when they are closed and latched, making your shed more secure. These channels are formed with a slight bend to the adjoining door edge—like parentheses facing each other: ( ). When the door handle is gently closed and latched, there should be a slight pressure sealing the doors and eliminating any gaps. Be sure to read the step-by-step instructions carefully to successfully install the door channels.

• **Les canaux pour le bord des portes (BLH)** sont conçus spécifiquement avec une courbe. Cette courbe s'assure un ajustage lorsque les portes se ferment, en faisant votre abri plus sûr. Ces canaux sont fabriqués avec une légère courbe au bord de la porte adjacente — comme les parenthèses qui font face l'une l'autre : ( ). Lorsque la poignée se ferme, il devrait un légère pression en rebouchant les portes et en éliminant des ouvertures. Assurez-vous de lire avec soin les instructions étape par étape pour pouvoir installer avec succès les canaux pour le bord des portes.

• **Los canales para el borde de las puertas (BLH)** son diseñados específicamente con una curva. Esta curva asegure un ajuste fijo cuando las puertas estén cerrados con pestillo, haciendo su caseta más segura. Estos canales están formados con una curva ligera al borde de la puerta adyacente, como los paréntesis uno enfrente al otro: ( ). Cuando el picaporte esté ligeramente cerrado con pestillo, debería tener una presión ligera sellando las puertas y eliminando los espacios. Asegúrese de leer detenidamente las instrucciones paso a paso para poder instalar exitosamente los canales para el borde de las puertas.



BLH

## ► SECTION 4 (CONTINUED) / SECTION 4 (SUITE) / SECCIÓN 4 (CONTINUACIÓN)

TOOLS AND PARTS REQUIRED / OUTILS ET QUINCAILLERIE REQUIS / INSTRUMENTAL Y HERRAJE REQUERIDOS

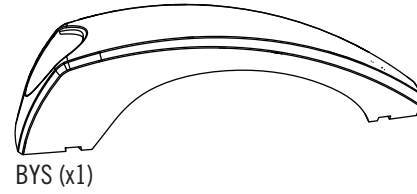
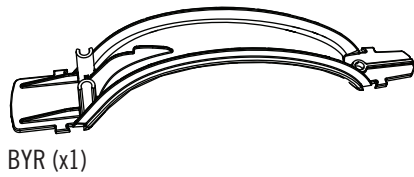

### 4.2

- Set the **Deadbolts (AHM)** down into the recesses at the top and bottom of the Door. Then, slide the **Door End Channel (BLH)** over the edge of the Door and the bottom of the Deadbolts as shown.
- Mettre les **loquets à pêne dormant (AHM)** dans les espaces vides aux parties supérieure et inférieure de la porte. Ensuite, faire glisser le **canal de la porte (BLH)** sur le bord de la porte et les parties inférieures des loquets à pêne dormant comme illustré.
- Meter los **cerrojos (AHM)** en los huecos a las partes superior e inferior de la puerta. Entonces, deslizar el **canal para el borde de la puerta (BLH)** sobre el borde de la puerta y las partes inferiores de los cerrojos como se muestra.

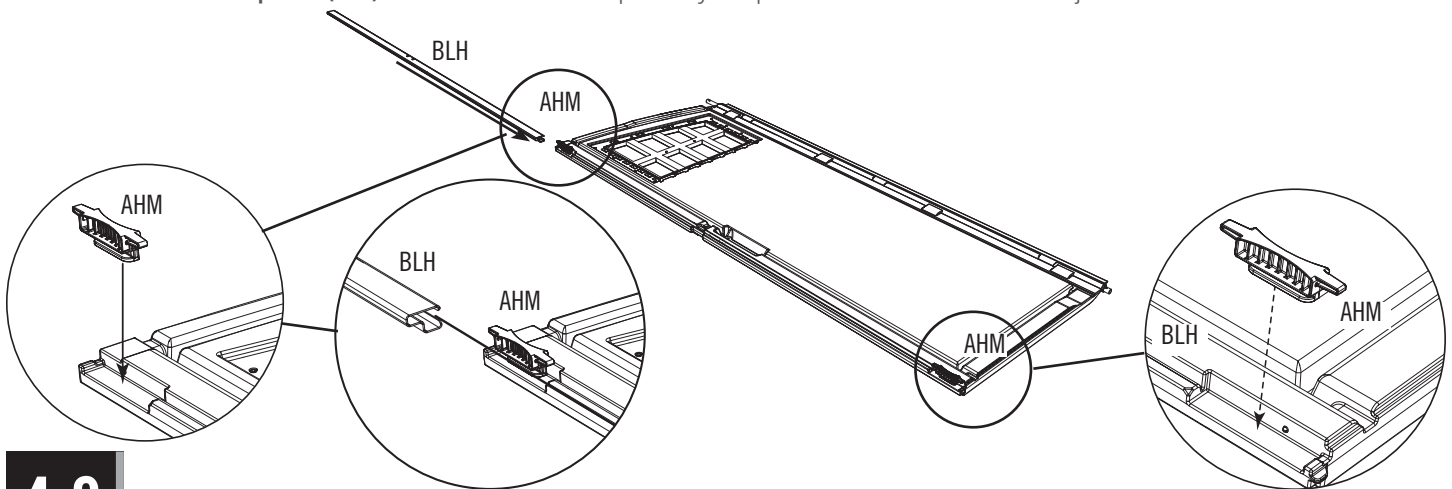

### 4.3

- Attach the two **Handle Pieces (BYR & BYS)** together as shown.
- Joindre les deux pièces de la **poignée (BYR et BYS)** comme illustré.
- Conectar las dos piezas del **picaporte (BYR y BYS)** como se muestra.

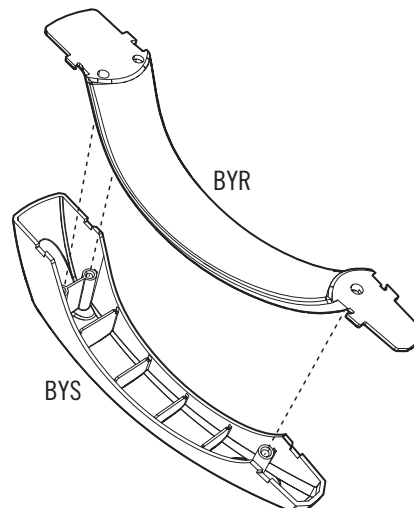

## ► SECTION 4 (CONTINUED) / SECTION 4 (SUITE) / SECCIÓN 4 (CONTINUACIÓN)

TOOLS AND PARTS REQUIRED / OUTILS ET QUINCAILLERIE REQUIS / INSTRUMENTAL Y HERRAJE REQUERIDOS

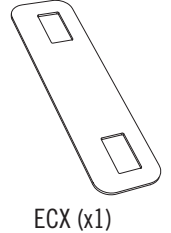
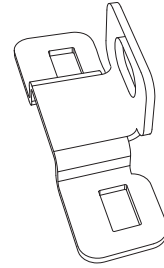
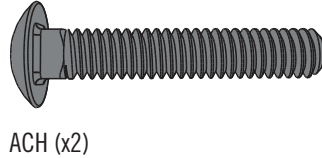
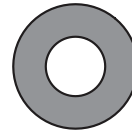
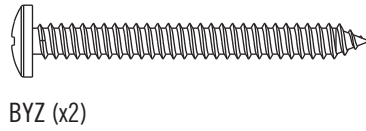
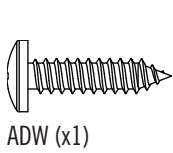
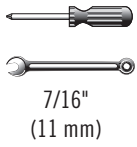

### 4.4

- Secure the Handle to the Door using the hardware provided. **Do not overtighten.**
- Fixer la poignée à la porte à l'aide de la quincaillerie incluse. **Ne pas trop serrer.**
- Fijar el picaporte a la puerta usando el herraje incluido. **No apretar demasiado.**

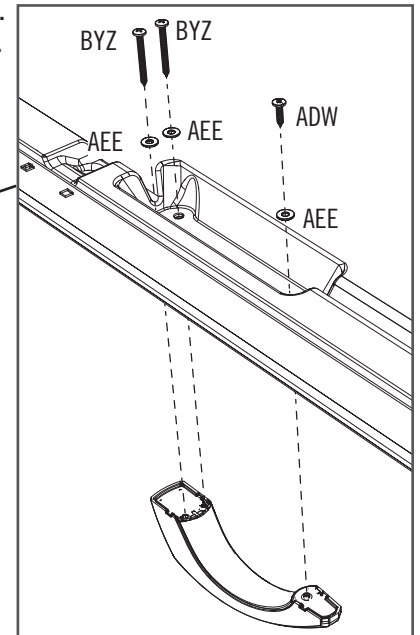
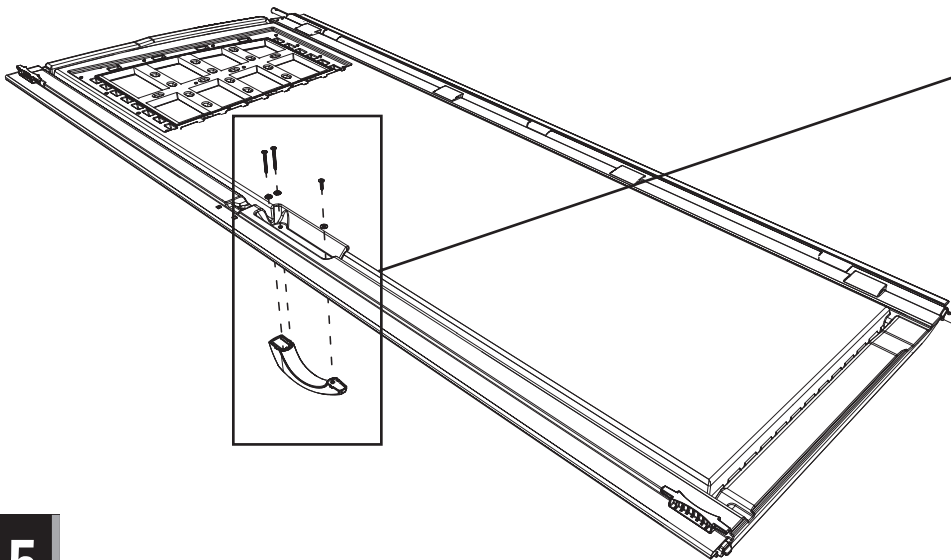

### 4.5

- Secure the **Strike Plate (ECX)** and **Lock Bracket (ECY)** to the Channel as shown. **Only hand-tighten the hardware for now.**
- Fixer la **gâche (ECX)** et le **plaque de verrouillage (ECY)** au canal comme illustré. **Serrer la quincaillerie à la main seulement en ce moment.**
- Fijar la **placa de impacto (ECX)** y el **placa de cierre (ECY)** al canal como se muestra. **Apretar el herraje sólo a mano en este momento.**

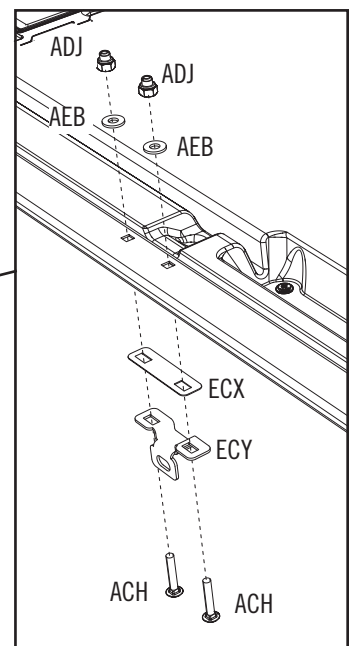
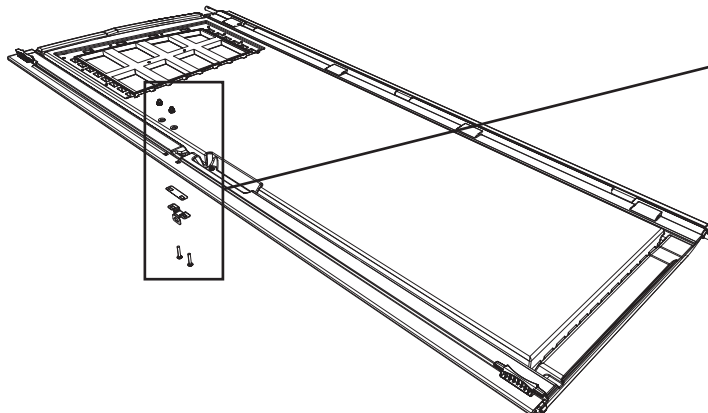



# 5

## RIGHT DOOR ASSEMBLY / ASSEMBLAGE DE LA PORTE DROITE / ENSAMBLE DE LA PUERTA DERECHA



### HARDWARE REQUIRED / QUINCAILLERIE REQUISE / HERRAJE REQUERIDO

Hardware Bag / Sac de quincaillerie / Bolsa de herraje

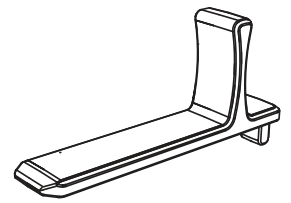
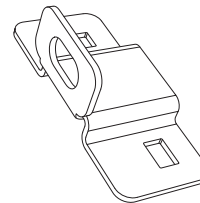
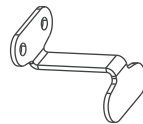
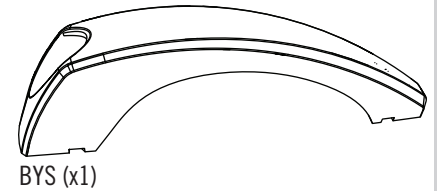
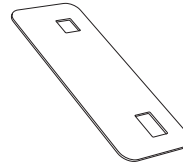
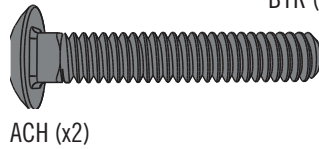
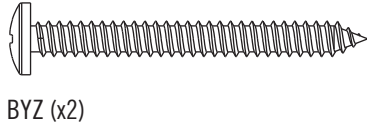
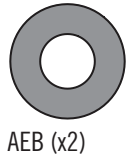
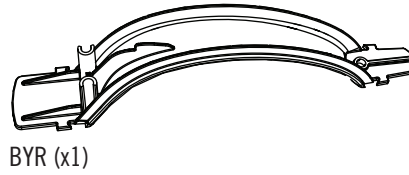
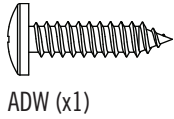

### PARTS REQUIRED / PIÈCES REQUISES / PIEZAS REQUERIDAS

Metal Parts / Pièces en métal / Piezas de metal

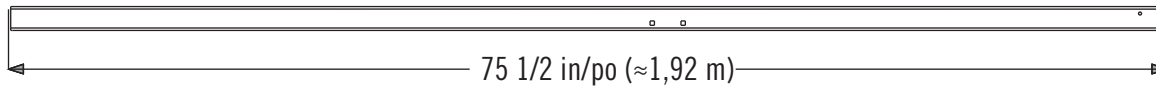

BLH (x1)

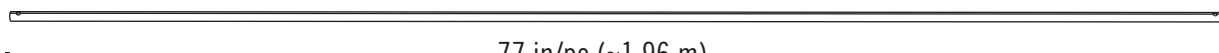
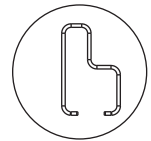

CRD (x1)

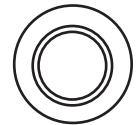

Plastic Parts / Pièces en plastique / Piezas de plástico

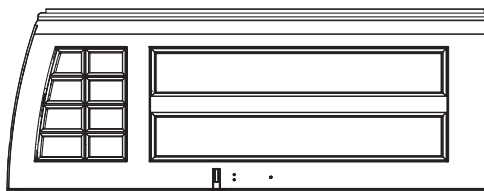

BDK (x1)

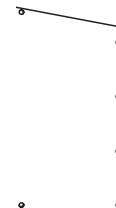

### TOOLS REQUIRED / OUTILS REQUIS / INSTRUMENTAL REQUERIDO



7/16 in/po (11 mm)

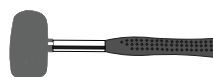

## ► SECTION 5 (CONTINUED) / SECTION 5 (SUITE) / SECCIÓN 5 (CONTINUACIÓN)

TOOLS AND PARTS REQUIRED / OUTILS ET QUINCAILLERIE REQUIS / INSTRUMENTAL Y HERRAJE REQUERIDOS



### 5.1

- Slide a **Hinge Tube (CRD)** down into the hole at the top of the **Right Door (BDK)**.
- Faire glisser le **tube d'articulation (CRD)** dans le trou au bord supérieur de la **porte droite (BDK)**.
- Deslizar el **tubo de articulación (CRD)** en el agujero a la parte superior de la **puerta derecha (BDK)**.

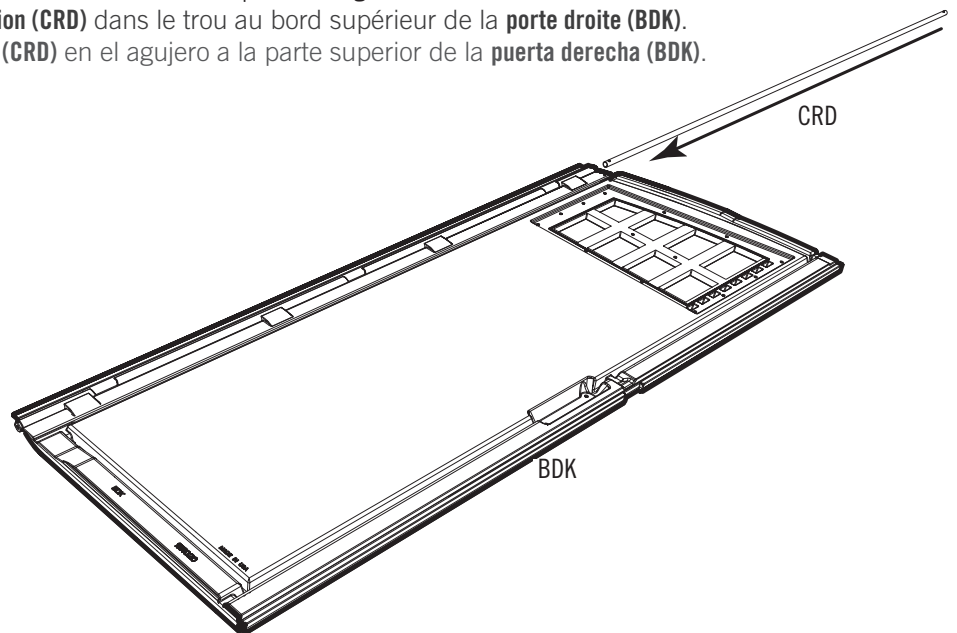

• **Door Channels (BLH)** are bowed by design, ensuring a tight fit when they are closed and latched, making your shed more secure. These channels are formed with a slight bend to the adjoining door edge—like parentheses facing each other: ( ). When the door handle is gently closed and latched, there should be a slight pressure sealing the doors and eliminating any gaps. Be sure to read the step-by-step instructions carefully to successfully install the door channels.

• **Les canaux pour le bord des portes (BLH)** sont courbés par design, en s'assurant un ajustage lorsque les portes se ferment, en faisant votre abri plus sûr. Ces canaux sont fabriqués avec une légère courbe au bord de la porte adjacent — comme les parenthèses qui font face l'une l'autre : ( ). Lorsque la poignée se ferme, il devrait un légère pression en rebouchant les portes et en éliminant des ouvertures. Assurez-vous de lire avec soin les instructions étape par étape pour pouvoir installer avec succès les canaux pour le bord des portes.

• **Los canales para el borde de las puertas (BLH)** son curvados por diseño, asegurando un ajuste fijo cuando las puertas estén cerrados con pestillo, haciendo su caseta más segura. Estos canales están formados con una curva ligera al borde de la puerta adyacente, como los paréntesis uno enfrente al otro: ( ). Cuando el picaporte esté ligeramente cerrado con pestillo, debería tener una presión ligera sellando las puertas y eliminando los espacios. Asegúrese de leer detenidamente las instrucciones paso a paso para poder instalar exitosamente los canales para el borde de las puertas.



BLH

## SECTION 5 (CONTINUED) / SECTION 5 (SUITE) / SECCIÓN 5 (CONTINUACIÓN)

TOOLS AND PARTS REQUIRED / Outils et quincaillerie requis / Instrumental y herraje requeridos

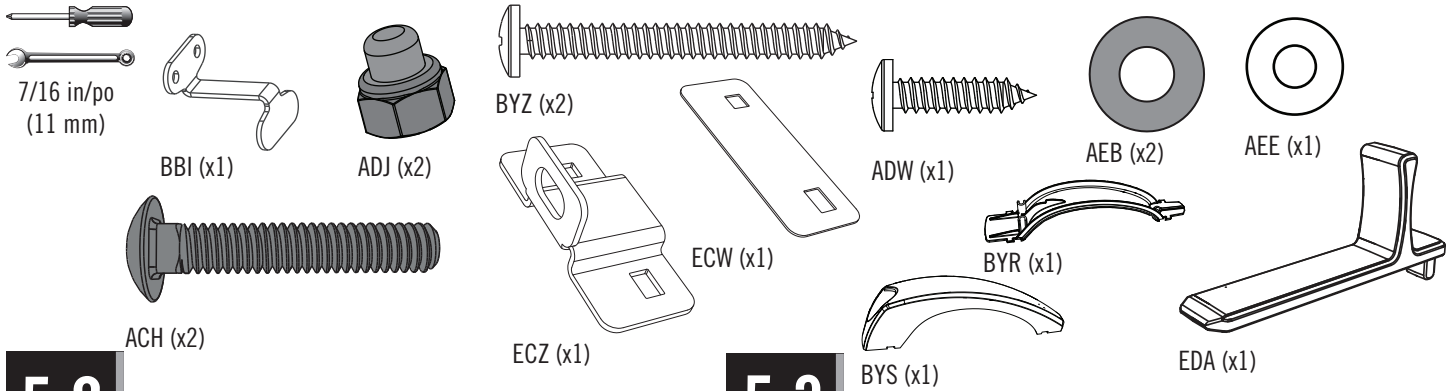

### 5.2

- Slide the **Door End Channel (BLH)** over the edge of the Door as shown.
- Faire glisser le **canal de la porte (BLH)** sur le bord de la porte comme illustré.
- Deslizar el **canal para el borde de la puerta (BLH)** sobre el borde de la puerta como se muestra.

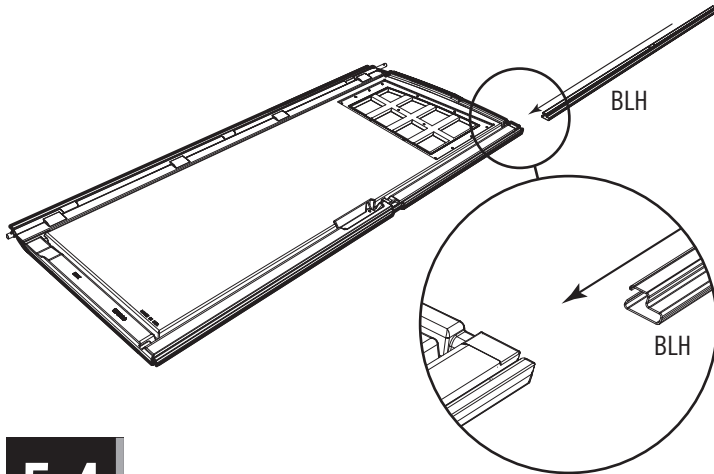

### 5.3

- Attach the two **Handle Pieces (BYR & BYS)** together as shown.
- Joindre les deux pièces de la **poignée (BYR et BYS)** comme illustré.
- Conectar las dos piezas del **picaporte (BYR y BYS)** como se muestra.

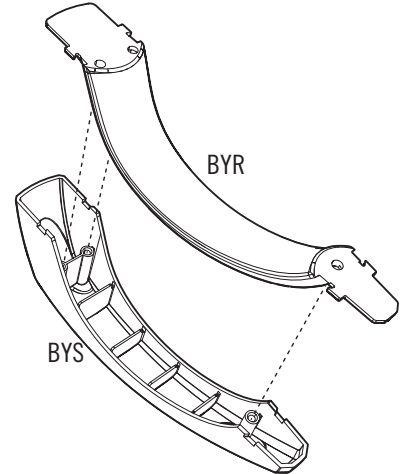

### 5.4

- Secure the Handle using the hardware included.
- Fixer la poignée à l'aide de la quincaillerie incluse.
- Fijar el picaporte usando el herraje incluido.

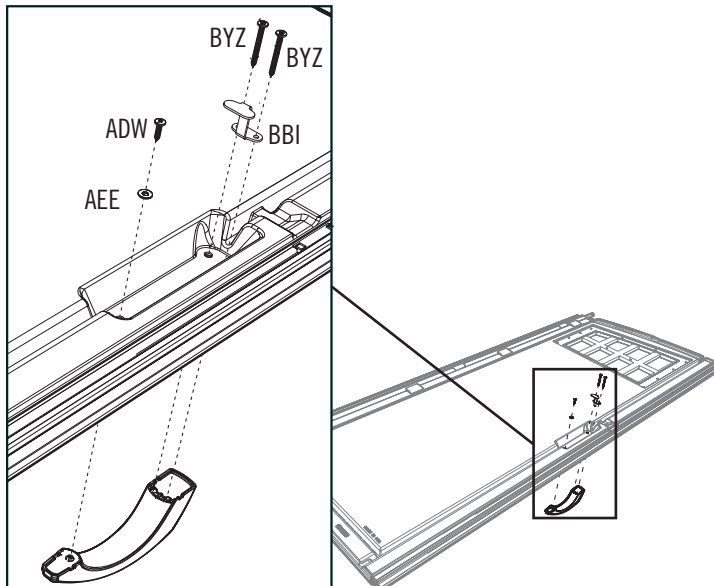

### 5.5

- Secure the Locking Hardware by hand only.
- Ne fixer qu'à la main seulement la quincaillerie de verrouillage.
- Fijar el herraje de cierre sólo a mano.

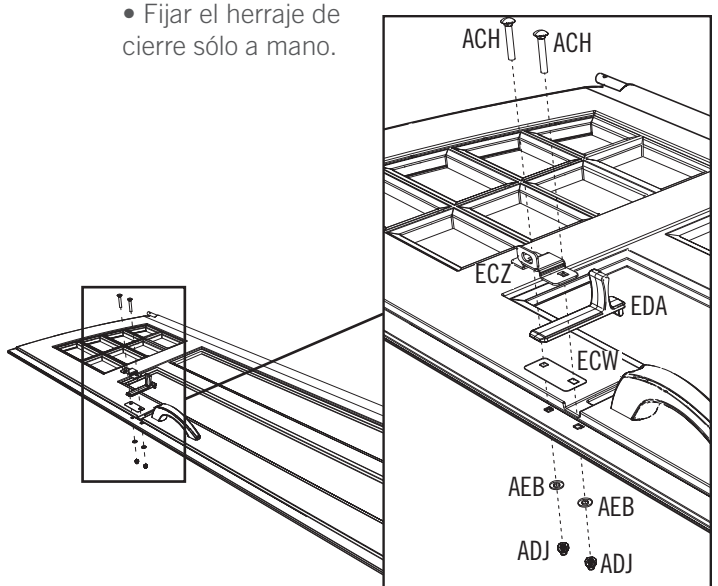

# 6

## FLOOR ASSEMBLY / ASSEMBLAGE DU PLANCHER / ENSAMBLE DEL PISO



### HARDWARE REQUIRED / QUINCAILLERIE REQUISE / HERRAJE REQUERIDO

Hardware Bag / Sac de quincaillerie / Bolsa de herraje

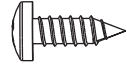

BQC (x20)



ADC (x1)

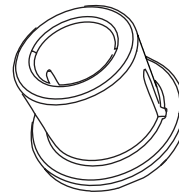

AHO (x2)



*Note: These Screws do not anchor the Floor; they only hold the Panels together.*

*Note : Ces vis n'ancrent pas le plancher ; ils ne servent que pour attacher les panneaux les uns aux autres.*

*Nota: Estos tornillos no anclan el piso; sirven sólo para sujetar los paneles los unos a los otros.*



### PARTS REQUIRED / PIÈCES REQUISES / PIEZAS REQUERIDAS

Plastic Parts / Pièces en plastique / Piezas de plástico

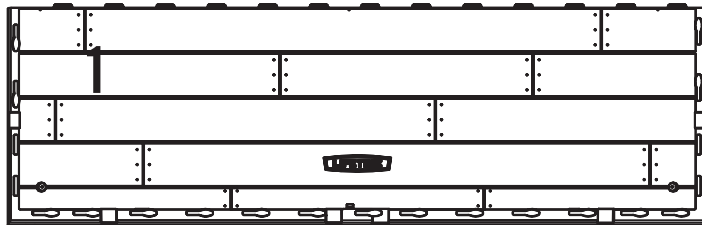

CUW (x2)

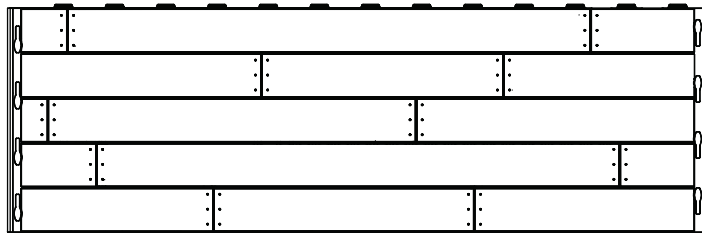

CUD (x2)



### TOOLS REQUIRED / OUTILS REQUIS / INSTRUMENTAL REQUERIDO



## ► SECTION 6 (CONTINUED) / SECTION 6 (SUITE) / SECCIÓN 6 (CONTINUACIÓN)

TOOLS AND HARDWARE REQUIRED / OUTILS ET QUINCAILLERIE REQUIS / INSTRUMENTAL Y HERRAJE REQUERIDOS

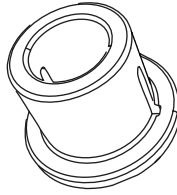

AHO (x2)



- If you have trouble with this section, follow the code below to view a video on the assembly in this section.
- En cas d'avoir des problèmes avec l'assemblage, suivre le code en bas pour voir un vidéo sur l'assemblage dans cette section.
- En caso de tener problemas con el ensamble, seguir el código debajo para ver un video sobre el ensamble en esta sección.



<http://go.lifetime.com/8x10floor>

### 6.1

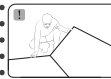

- Hold an **Inner Floor Panel (CUD)** at a 45° angle and slide the tabs along the edge underneath an **Outer Floor Panel (CUW)**. The tabs interlock. Lay Panel flat.
- Mettre un **panneau de plancher intérieur (CUD)** à un angle de 45° et faire glisser les languettes le long du bord au-dessus du **panneau de plancher extérieur (CUW)**. Les languettes s'enclenchent les uns les autres. L'étendre par terre.
- Meter un **panel de piso interior (CUD)** a un ángulo de 45° y deslice las lengüetas a lo largo del borde debajo el **panel de piso exterior (CUW)**. Las lengüetas se entrelazan las unas con las otras. Aplanar el panel.

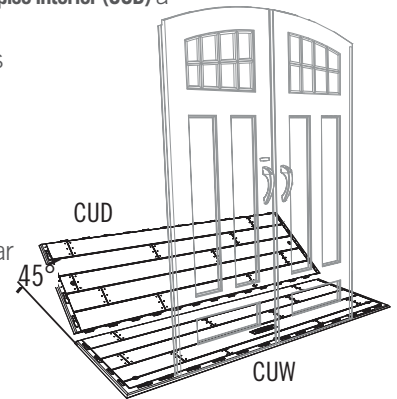

### 6.2

- Attach the second **Inner Floor Panel (CUD)** to the first Inner Floor Panel.
- Joindre le deuxième **panneau de plancher intérieur (CUD)** au premier panneau de plancher intérieur.
- Conectar el segundo **panel de piso interior (CUD)** al primer panel de piso interior.

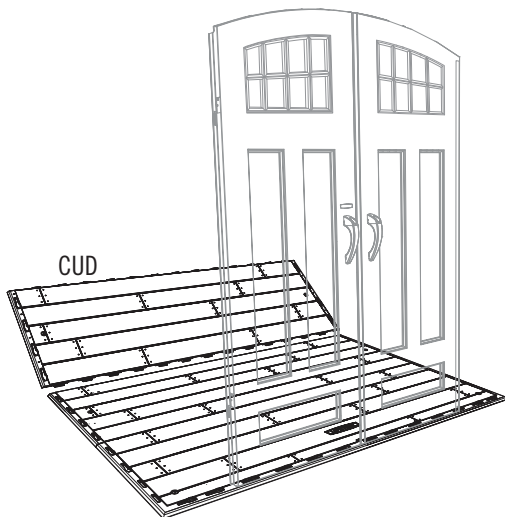

### 6.3

- Then, attach the last **Outer Floor Panel (CUW)** to the Inner Floor Panel. Insert the **Bushings (AHO)**.
- Ensuite, attacher un autre **panneau de plancher intérieur (CUW)** au panneau de plancher intérieur. Insérer les **bagues (AHO)**.
- Entonces, conectar otro **panel de piso exterior (CUW)** al panel de piso interior. Insertar los **casquillos (AHO)**.

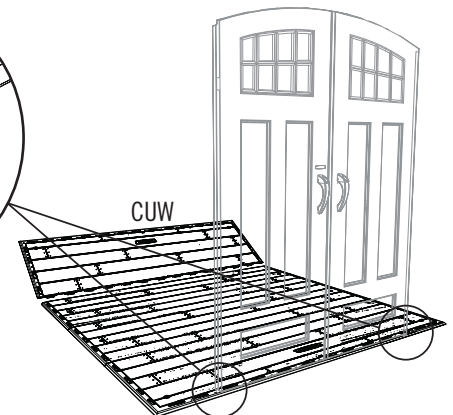
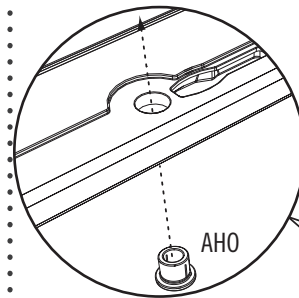

## ► SECTION 6 (CONTINUED) / SECTION 6 (SUITE) / SECCIÓN 6 (CONTINUACIÓN)

TOOLS AND HARDWARE REQUIRED / OUTILS ET QUINCAILLERIE REQUIS / INSTRUMENTAL Y HERRAJE REQUERIDOS

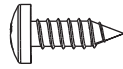

BQC (x18)

### 6.4

- Finally, insert the **Screws (BQC)** through the divots in the Floor Panels and into the tabs of the adjacent Floor Panels. (The divots are near the seams of the Floor Panels.)
- Enfin, insérer les **vis (BQC)** à travers les marques dans les panneaux de plancher et dans les languettes du panneaux de plancher contigu. (Les marques se trouvent près des jonctions des panneaux de plancher.)
- Por último, insertar los **tornillos (BQC)** a través de las marcas en los paneles de piso y dentro de las lengüetas de los paneles de piso adyacentes. (Se encuentran las marcas cerca de las juntas de los paneles de piso.)



*Note: These Screws do not anchor the Floor; they only hold the Panels together.*

*Note : Ces vis n'ancrent pas le plancher ; ils ne servent que pour attacher les panneaux les uns aux autres.*

*Nota: Estos tornillos no anclan el piso; sirven sólo para sujetar los paneles los unos a los otros.*

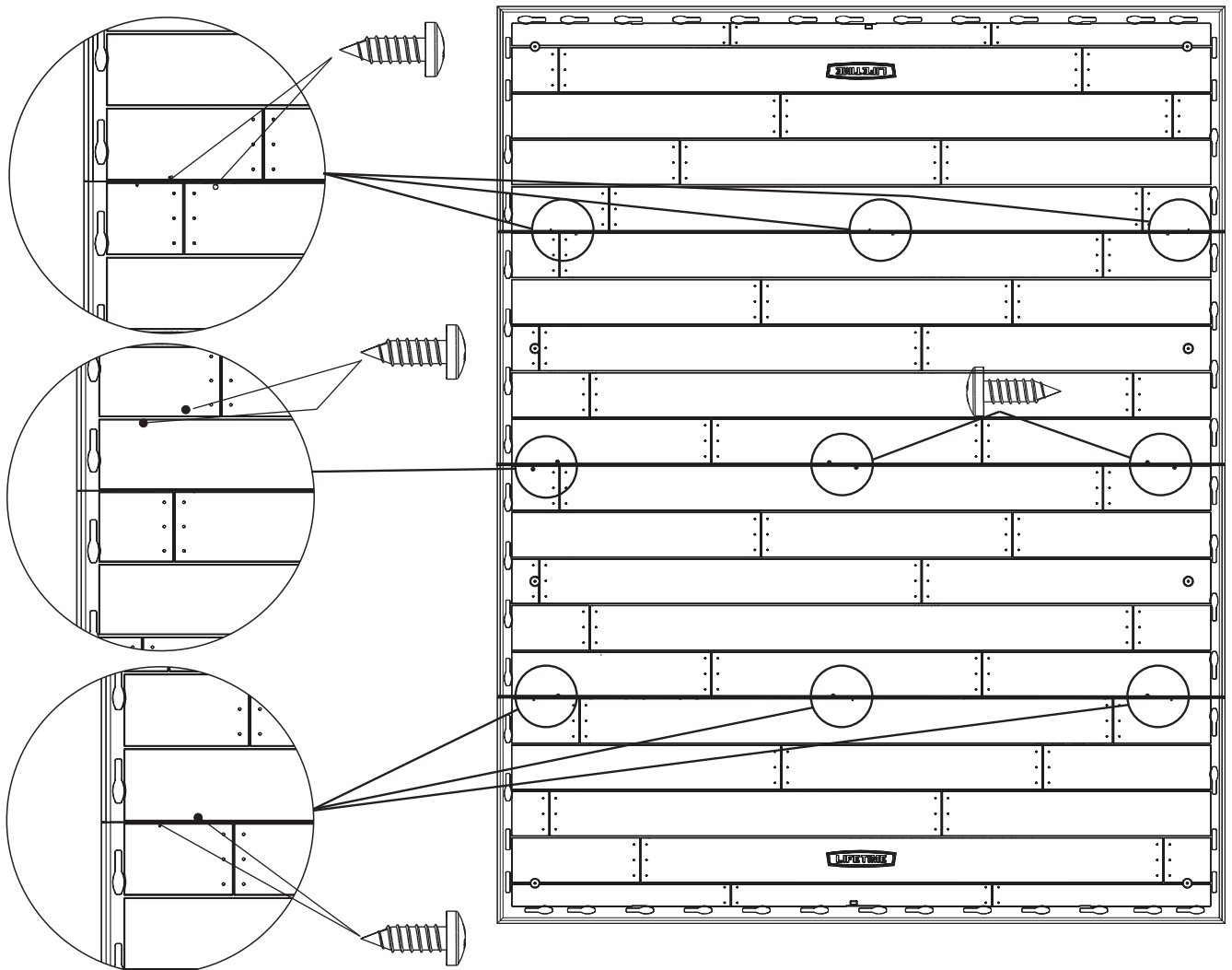



# 7

## WALL ASSEMBLY / ASSEMBLAGE DES MURS / ENSAMBLE DE LOS MUROS



### HARDWARE REQUIRED / QUINCAILLERIE REQUISE / HERRAJE REQUERIDO

Hardware Bag / Sac de quincaillerie / Bolsa de herraje

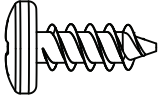

ADZ (x100)\*

- \* Not all hardware will be used in the section.
- \* La quincaillerie n'est pas utilisée au complet dans la section.
- \* No se utilizará todo el herraje en la sección.



### PARTS REQUIRED / PIÈCES REQUISES / PIEZAS REQUERIDAS

Metal Parts / Pièces en métal / Piezas de metal

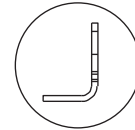
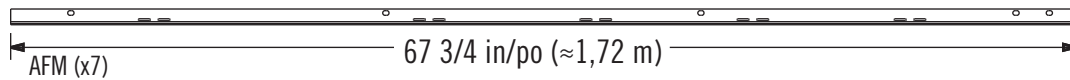

Plastic Parts / Pièces en plastique / Piezas de plástico

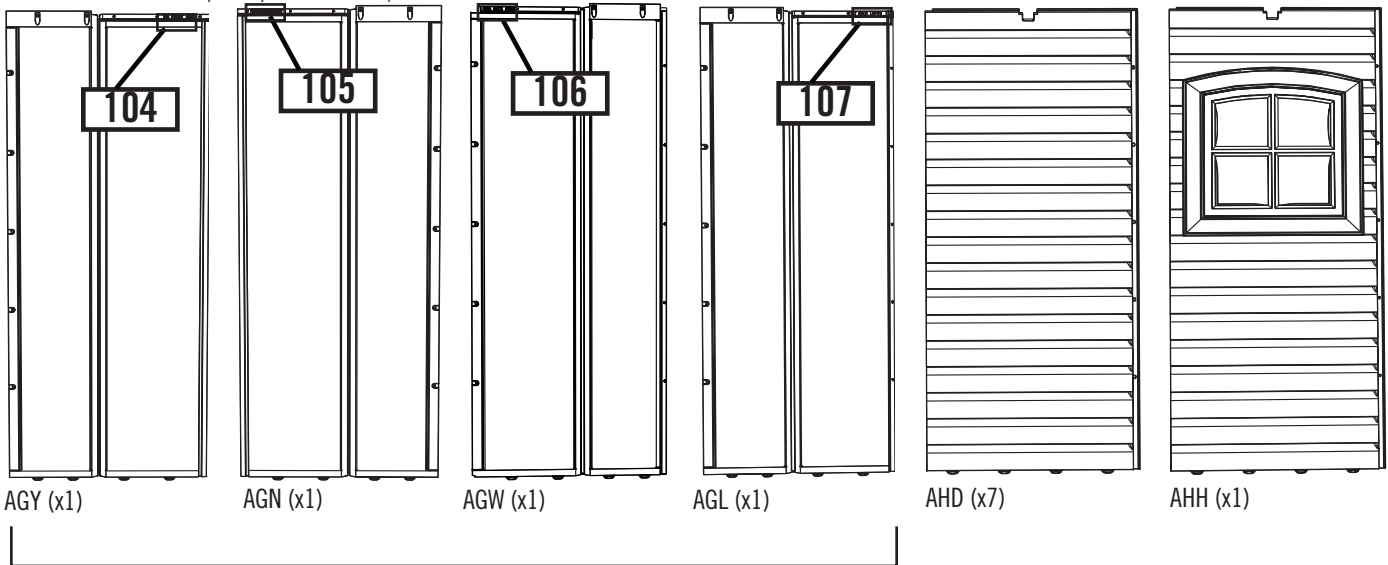

Back Surface of Panels / Surface arrière des panneaux / Superficie trasera de los paneles



### TOOLS REQUIRED / OUTILS REQUIS / INSTRUMENTAL REQUERIDO



AIW (x1)

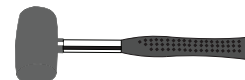

## ► SECTION 7 (CONTINUED) / SECTION 7 (SUITE) / SECCIÓN 7 (CONTINUACIÓN)

TOOLS AND HARDWARE REQUIRED / OUTILS ET QUINCAILLERIE REQUIS / INSTRUMENTAL Y HERRAJE REQUERIDOS

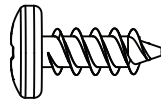

ADZ (x28)

### 7.1

- Top end
- Extremo superior
- Extrémité supérieure



- No screw in top hole.
- Aucune vis dans le trou supérieur.
- Ningún tornillo en el agujero superior.

- Secure two **wall support channels (AFM)** at the outer edges on the one (1) **window panels (AHH)** using eight (8) **screws (ADZ)** for each.
- Fixez deux (2) **renforts de soutien mural (AFM)** sur les bords extérieurs de chacun des deux (2) **volets de fenêtre (AHH)** à l'aide de huit (8) **vis (ADZ)**.
- Asegure dos (2) **canales de soporte de pared (AFM)** en los bordes exteriores de los dos (2) **paneles de ventana (AHH)** utilizando ocho (8) **tornillos (ADZ)** para cada uno.

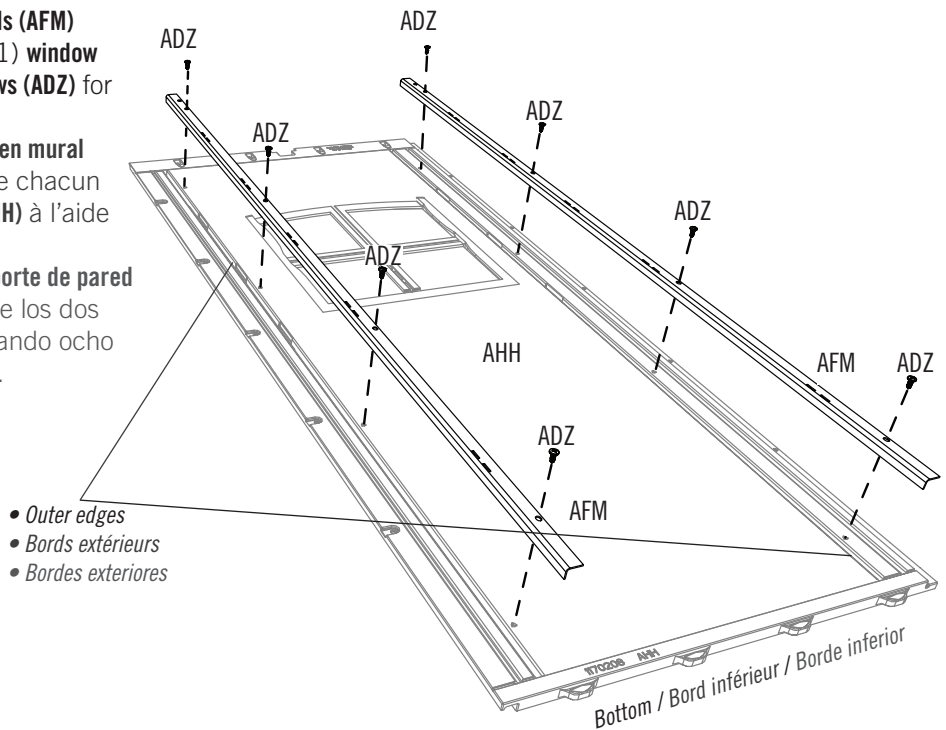

- Outer edges
- Bords extérieurs
- Bordes exteriores

### 7.2

- Top end
- Extremo superior
- Extrémité supérieure



- No screw in top hole.
- Aucune vis dans le trou supérieur.
- Ningún tornillo en el agujero superior.

- Secure a **wall support channel (AFM)** at the middle of the notch on five (5) **wall panels (AHD)** using four (4) **screws (ADZ)** for each. The remaining two (2) wall panels will have the wall support channels installed in the next section.
- Fixez un **renfort de soutien mural (AFM)** au centre de l'encoche de chacun cinq (5) **panneaux muraux (AHD)** à l'aide de quatre (4) **vis (ADZ)**. Les deux (2) panneaux muraux restants auront les chenaux de support muraux installés dans la section suivante.
- Asegure un **canal de soporte de pared (AFM)** en el centro de la muesca en cinco (5) **paneles de pared (AHD)** utilizando cuatro (4) **tornillos (ADZ)** para cada uno. Los canales de apoyo para la pared de los dos (2) paneles restantes se instalarán en la siguiente sección.

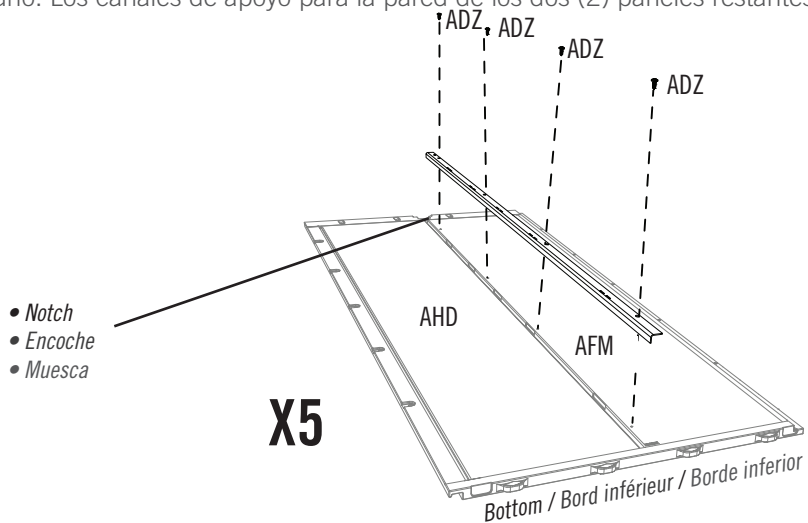

- Notch
- Encoche
- Muesca

## ► SECTION 7 (CONTINUED) / SECTION 7 (SUITE) / SECCIÓN 7 (CONTINUACIÓN)

TOOLS AND HARDWARE REQUIRED / OUTILS ET QUINCAILLERIE REQUIS / INSTRUMENTAL Y HERRAJE REQUERIDOS



- If you have trouble with this section, follow the code below to view a video on how to assemble the Walls.
- En cas d'avoir des problèmes avec cette section, suivre le code en bas pour voir un vidéo sur l'assemblage de cette section.
- En caso de tener problemas con esta sección, seguir el código debajo para ver un video sobre el ensamble de esta sección.

 YouTube



<http://go.lifetime.com/8x10horsidingwall>

### 7.3

- Insert the two left-most tabs at the bottom of the **Corner Panel (AGY)** into the two right-most slots along the front edge of the Floor.
- Insérer les deux languettes gauches au fond du **panneau angulaire (AGY)** dans les deux rainures droites le long du bord du plancher.
- Insertar las lengüetas al borde inferior del **panel angular (AGY)** en las ranuras a lo largo del borde del piso.

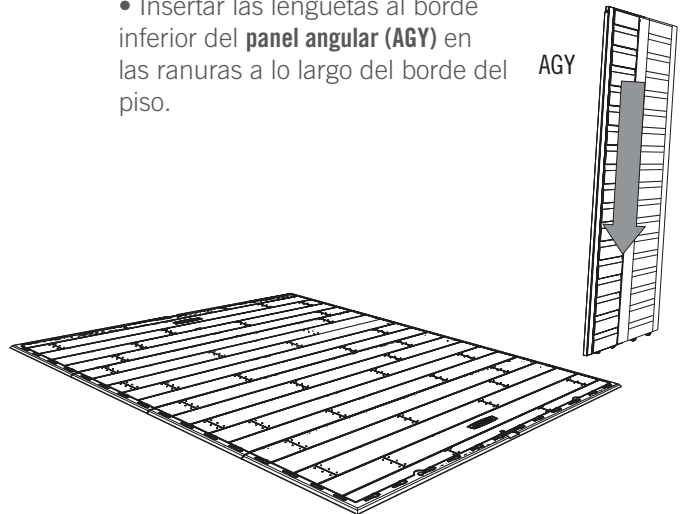

### 7.4

- Slide the Panel to the left.
- Faire glisser le panneau à gauche.
- Deslizar el panel a la izquierda.

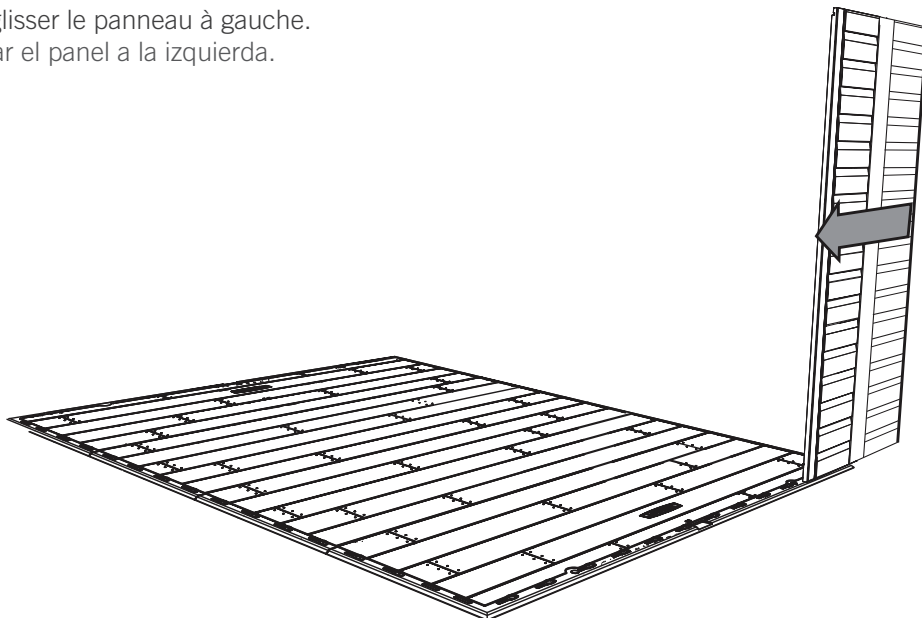

## ► SECTION 7 (CONTINUED) / SECTION 7 (SUITE) / SECCIÓN 7 (CONTINUACIÓN)

TOOLS AND HARDWARE REQUIRED / OUTILS ET QUINCAILLERIE REQUIS / INSTRUMENTAL Y HERRAJE REQUERIDOS



AIW (x1)

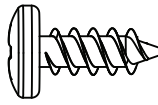

ADZ (x15)

### 7.5

• Bend Corner Panel, and pull down on the Panel to snap the remaining tabs in place. To help with insertion, place the **Wood Block (AIW)** under the Floor Panel directly under the tab being inserted. You should hear a “click” when the tab pops into place. **Repeat this step for the second tab.**

• Plier le panneau angulaire, et insérer les autres languettes. Pour aider avec le montage, mettre le **bloque en bois (AIW)** sous le panneau de plancher directement sous la languette à insérer. **Répéter ce processus pour la deuxième languette.**

**Répéter ce processus pour la deuxième languette.**

• Doblar el panel angular e introduzca las lengüetas restantes. Para ayudar con el armado, deslizar el **bloque de madera (AIW)** debajo el panel de piso directamente debajo la lengüeta a insertar. Se escucha un «clic» cuando la lengüeta se sienta en su lugar. **Repetir este proceso para la segunda lengüeta.**

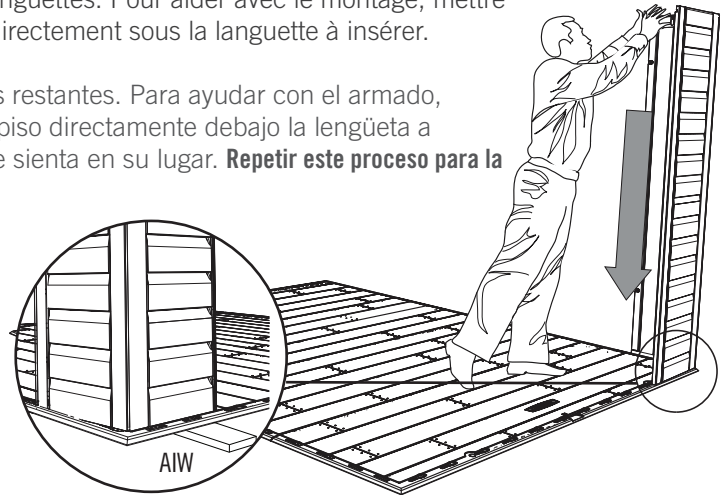

### 7.6

• One at a time, insert the four tabs at the bottom of the **Wall Panels (AHD)** or **Window Wall Panel (AHH)** into the next four slots along the edge of the Floor, and slide the Panels forward. **Insert the Window Wall Panel on either side of the Shed. You may need to use a rubber mallet and the block of wood to gently tap the Panel forward.** Attach the Panels together with five (5) **Screws (ADZ).**

• Un par un, insérer les quatre languettes au fond du **panneau mural (AHD)** ou du **panneau mural pour la fenêtre (AHH)**

dans les quatre rainures suivantes le long du bord du plancher, et faire glisser les panneaux vers le bord avant. **Insérer le panneau mural pour la fenêtre soit le côté droit soit le côté gauche de l'abri. Si besoin, utiliser un maillet en caoutchouc et le bloc en bois pour mettre en place les panneaux.** Attacher les panneaux l'un à l'autre à l'aide de cinq (5) **vis (ADZ).**

• Uno por uno, insertar las cuatro lengüetas al borde inferior del **panel mural (AHD)** o **panel mural para la ventana (AHH)** en las cuatro ranuras siguientes a lo largo del borde del piso, y deslizar los paneles hacia el borde delantero. **Insertar el panel mural para la ventana en cualquiera de los dos lados de la caseta. Si es necesario, usar un mazo de goma y el bloque de madera para dar un golpecito al panel para ubicar cuidadosamente el panel en su lugar.**

Sujetar los paneles los unos a los otros usando cinco (5) **tornillos (ADZ).**

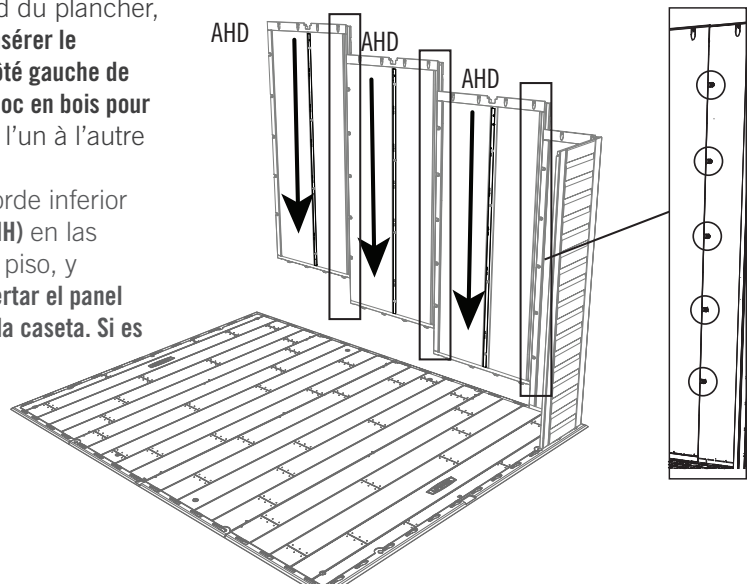

## ► SECTION 7 (CONTINUED) / SECTION 7 (SUITE) / SECCIÓN 7 (CONTINUACIÓN)

TOOLS AND HARDWARE REQUIRED / OUTILS ET QUINCAILLERIE REQUIS / INSTRUMENTAL Y HERRAJE REQUERIDOS



AIW (x1)

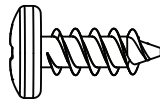

ADZ (x35)

### 7.7

- Insert this **Corner Wall Panel (AGW)** in the same way as the first one.
- Insérer le **panneau angulaire (AGW)** de la même manière que le premier panneau angulaire.
- Insertar este **panel angular (AGW)** en la misma manera que el primer panel angular.

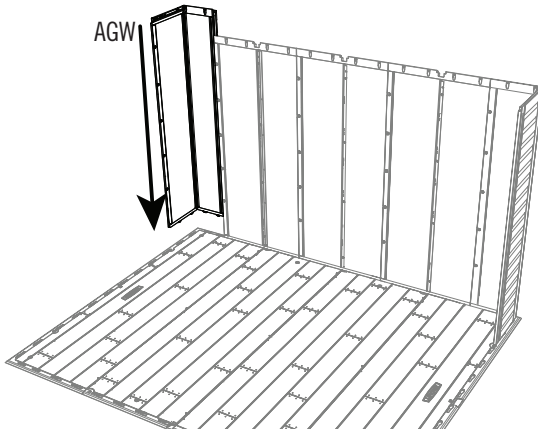

### 7.8

- Insert these **Wall Panels (AHD)** in the same way as the previous ones. **Do not place Window Wall Panels along the rear of the the Shed.**
- Insérer ces **panneaux muraux (AHD)** de la même manière que les panneaux précédents. **Ne pas insérer les deux panneaux muraux pour la fenêtre le long de bord arrière de l'abri.**
- Insertar estos **paneles murales (AHD)** en la misma manera que los paneles anteriores. **No insertar los paneles murales para la ventana a lo largo del borde trasero de la caseta.**

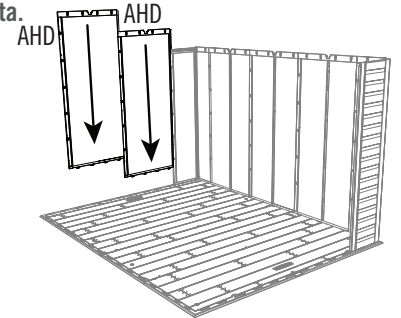

### 7.9

- Insert this **Corner Wall Panel (AGL)** in the same way as the first one.
- Insérer le **panneau angulaire (AGL)** de la même manière que le premier panneau angulaire.
- Insertar este **panel angular (AGL)** en la misma manera que el primer panel angular.

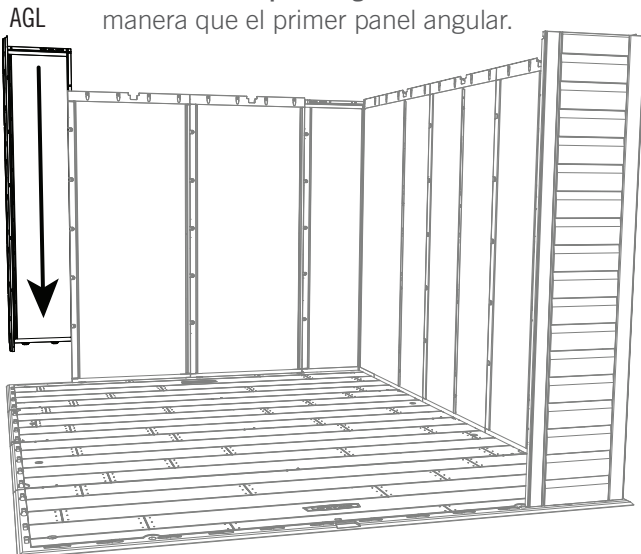

### 7.10

- Insert these Wall Panels in the same way as the other side. **The Window Wall Panel may be inserted on either side of the Shed.**
- Insérer ces panneaux muraux de la même manière que ceux de l'autre côté. **Le panneau mural pour la fenêtre s'insère soit le côté droit soit le côté gauche de l'abri.**
- Insertar estos paneles murales en la misma manera que los del otro lado. **Se puede insertar el panel mural para la ventana en cualquiera de los dos lados de la caseta.**

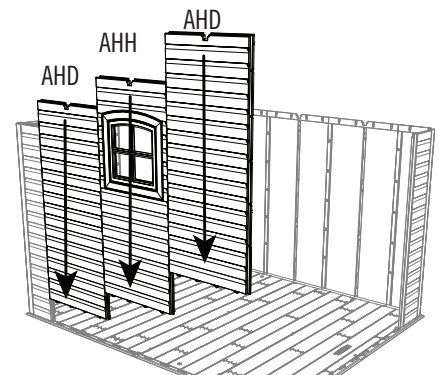

## ► SECTION 7 (CONTINUED) / SECTION 7 (SUITE) / SECCIÓN 7 (CONTINUACIÓN)

TOOLS AND HARDWARE REQUIRED / OUTILS ET QUINCAILLERIE REQUIS / INSTRUMENTAL Y HERRAJE REQUERIDOS



AIW (x1)

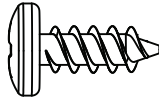

ADZ (x5)

### 7.11

- Insert this **Corner Wall Panel (AGN)** in the same way as the first one.
- Insérer le **panneau angulaire (AGN)** dans la même manière que le premier panneau angulaire.
- Insertar este **panel angular (AGN)** en la misma manera que el primer panel angular.

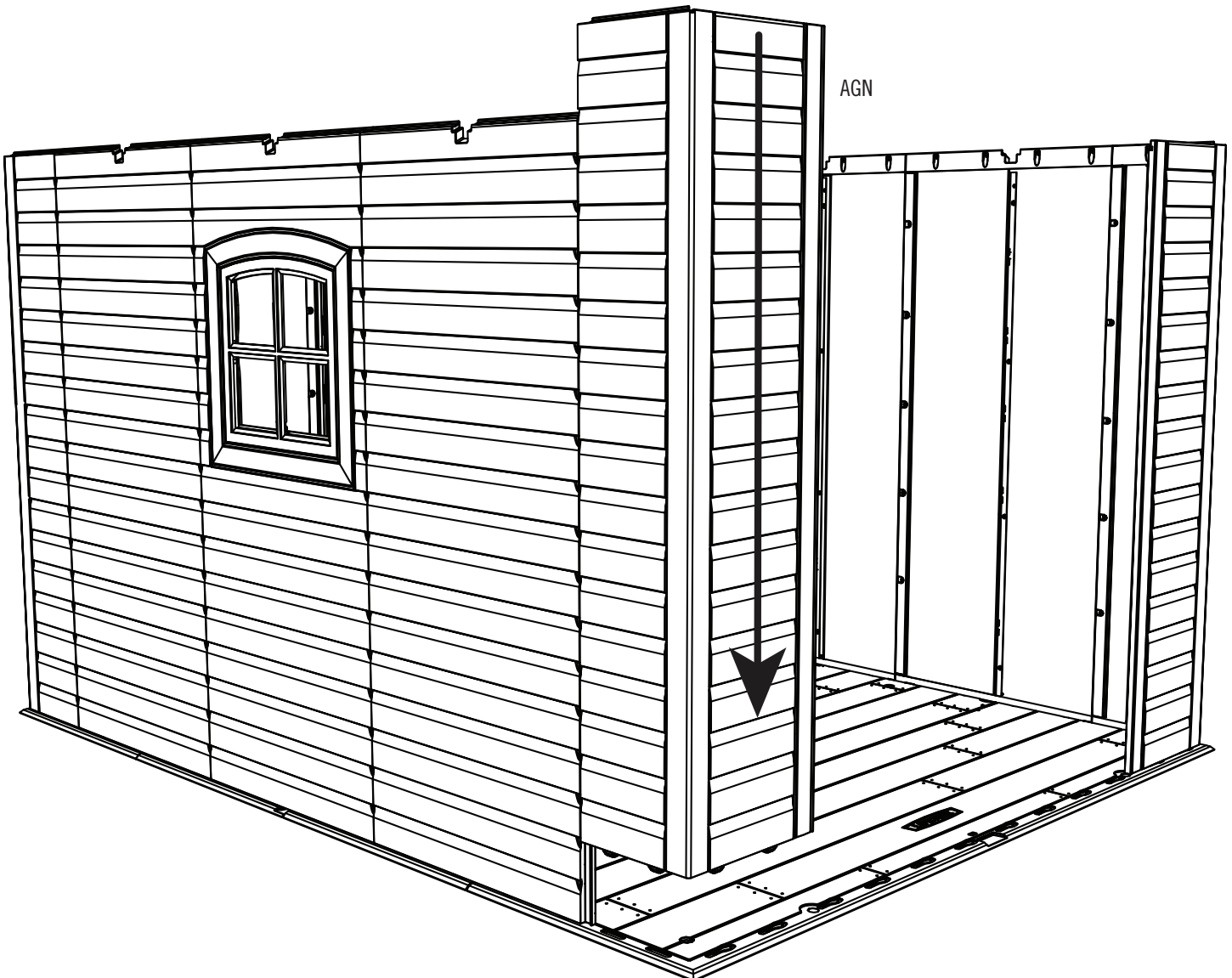



# 8

## SHELVING INSTALLATION / INSTALLATION DU RAYONNAGE / INSTALACIÓN DE LA ESTANTERÍA



### HARDWARE REQUIRED / QUINCAILLERIE REQUISE / HERRAJE REQUERIDO

Hardware Bag / Sac de quincaillerie / Bolsa de herraje

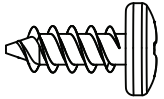

ADZ (x14)



AIY (x2)



### PARTS REQUIRED / PIÈCES REQUISES / PIEZAS REQUERIDAS

Metal Parts / Pièces en métal / Piezas de metal

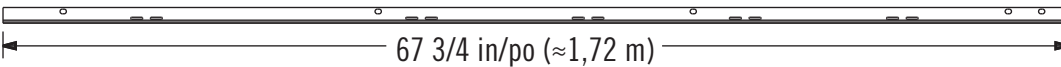

AFM (x2)

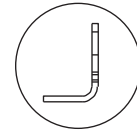

Plastic Parts / Pièces en plastique / Piezas de plástico



AFV (x1)



### TOOLS REQUIRED / OUTILS REQUIS / INSTRUMENTAL REQUERIDO



## ► SECTION 8 (CONTINUED) / SECTION 8 (SUITE) / SECCIÓN 8 (CONTINUACIÓN)

TOOLS AND PARTS REQUIRED / Outils et quincaillerie requis / Instrumental y herraje requeridos

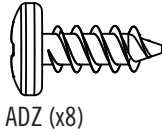

- If you have trouble with this section, follow the code below to view a how-to video on this section.
- En cas d'avoir problèmes avec l'assemblage dans cette section, suivre le code en bas pour voir un vidéo sur l'assemblage dans cette section.
- En caso de problemas con el ensamble en esta sección, seguir el código debajo para ver un video sobre el ensamble en esta sección.



<http://go.lifetime.com/90shelf>

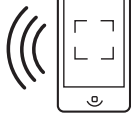

### 8.1

- The right **Wall/Shelf Support Channel (AFM)** goes in the slot directly under the notch in the Wall Panel. The left Wall Support Channel goes in the slot to the right of the notch in the Wall Panel.
- Le **canal de support du mur/étagère (AFM)** droit s'attache dans la rainure directement sous l'encoche dans le panneau mural. Le canal de support du mur/étagère gauche s'attache dans la rainure à la droite de l'encoche du panneau mural.
- El **canal de soporte para la pared/estante (AFM)** derecho se sujeta dentro de la ranura directamente debajo la muesca en el panel de pared. El canal de soporte para la pared izquierdo se sujeta dentro de la ranura a la derecha de la muesca en el panel de pared.

Notches / Encoches / Muecas

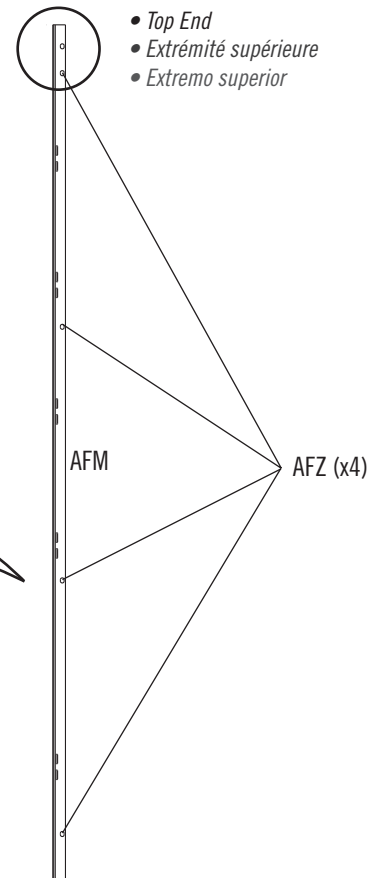
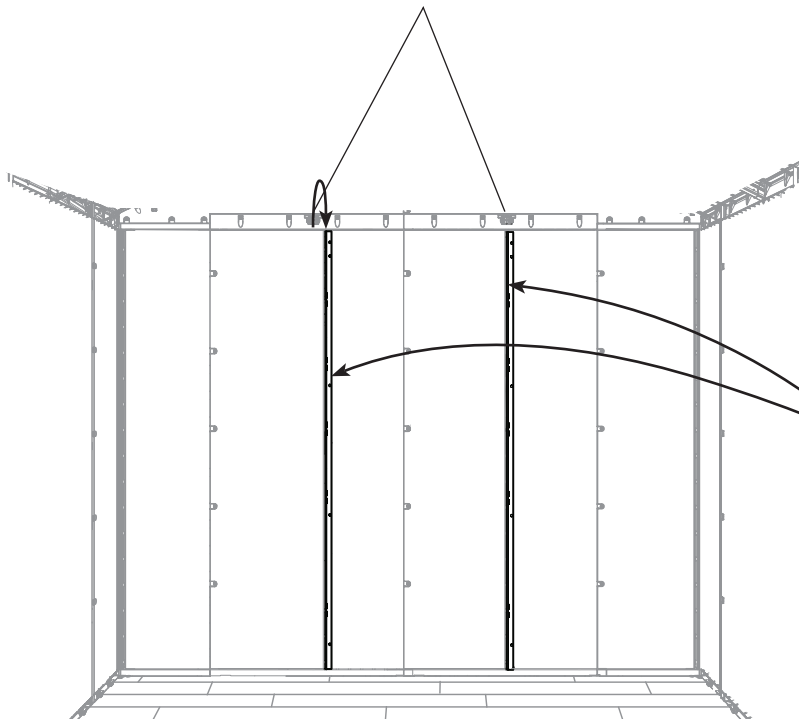



# PARTS IDENTIFIER / IDENTIFICATEUR DE PIÈCES / IDENTIFICADOR DE PIEZAS

CONTENTS OF BOX 1 / CONTENU DE LA BOÎTE 1 / CONTENIDO DE LA CAJA 1

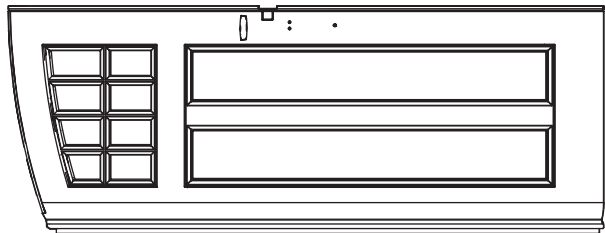

BDJ (x1)

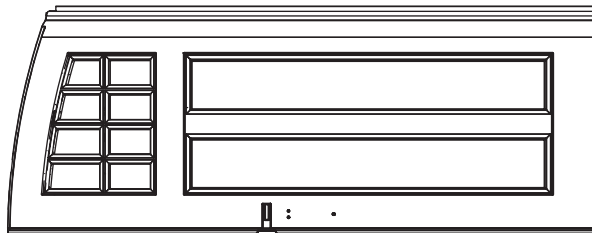

BDK (x1)

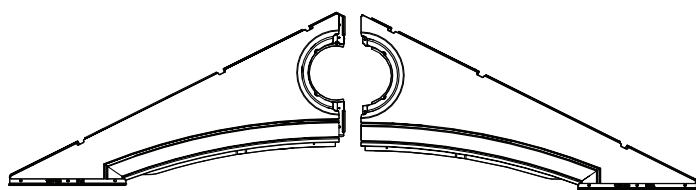

EVZ (x1)

EWA (x1)

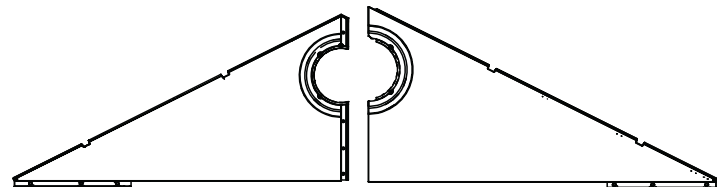

AGH (x1)

AGI (x1)

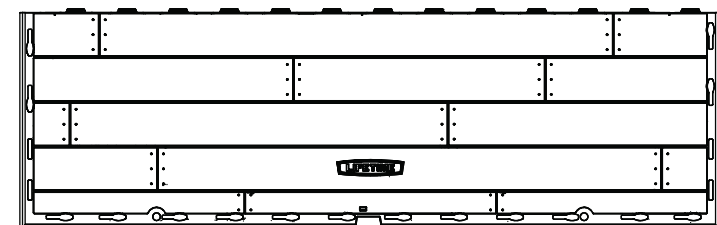

CUW (x2)

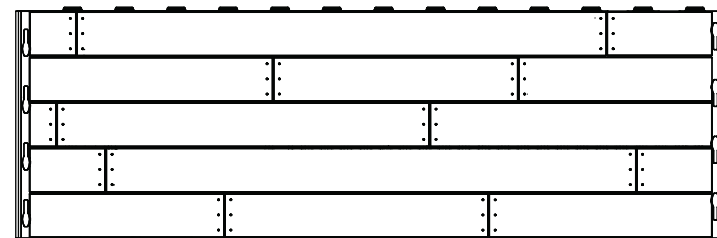

CUD (x2)



CVG (x4)

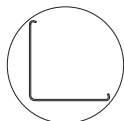

AFV (x1)

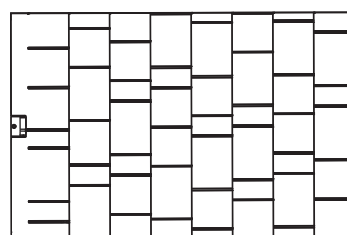

AGQ (x8)

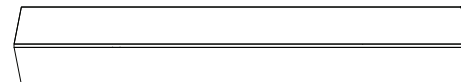

CVA (x2)



45 1/2 in/po (1,16 m)  
CVC (x2)



45 1/2 in/po (1,16 m)  
CVE (x2)

Remove this section for quick reference / Enlever cette section pour référence rapide / Retirar esta sección para referencia rápida



# PARTS IDENTIFIER / IDENTIFICATEUR DE PIÈCES / IDENTIFICADOR DE PIEZAS

CONTENTS METAL KIT / CONTENU DU KIT DE PIÈCES EN MÉTAL / CONTENIDO DEL KIT DE PIEZAS DE METAL

Remove this section for quick reference / Enlever cette section pour référence rapide / Retirar esta sección para referencia rápida

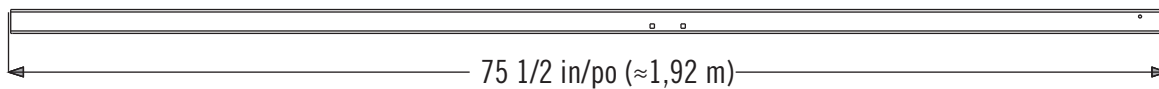

BLH (x2)

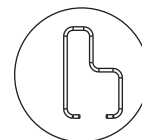

EYS (x1)

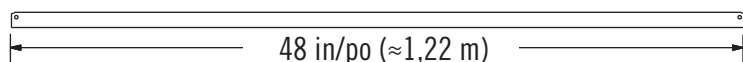

AFG (x3)

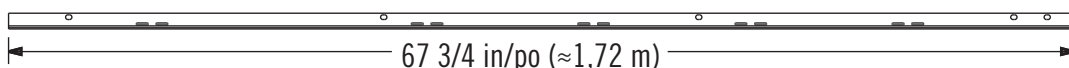
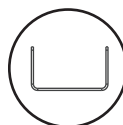

AFM (x9)

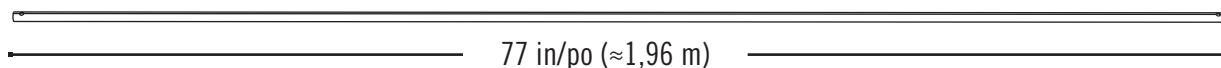
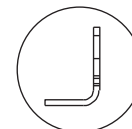

CRD (x2)

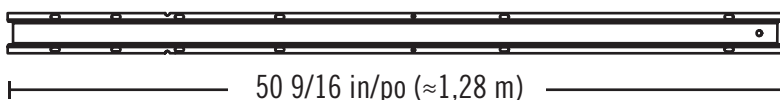

DSR (x6)





# PARTS IDENTIFIER / IDENTIFICATEUR DE PIÈCES / IDENTIFICADOR DE PIEZAS

CONTENTS OF BOX 1 / CONTENU DE LA BOÎTE 1 / CONTENIDO DE LA CAJA 1

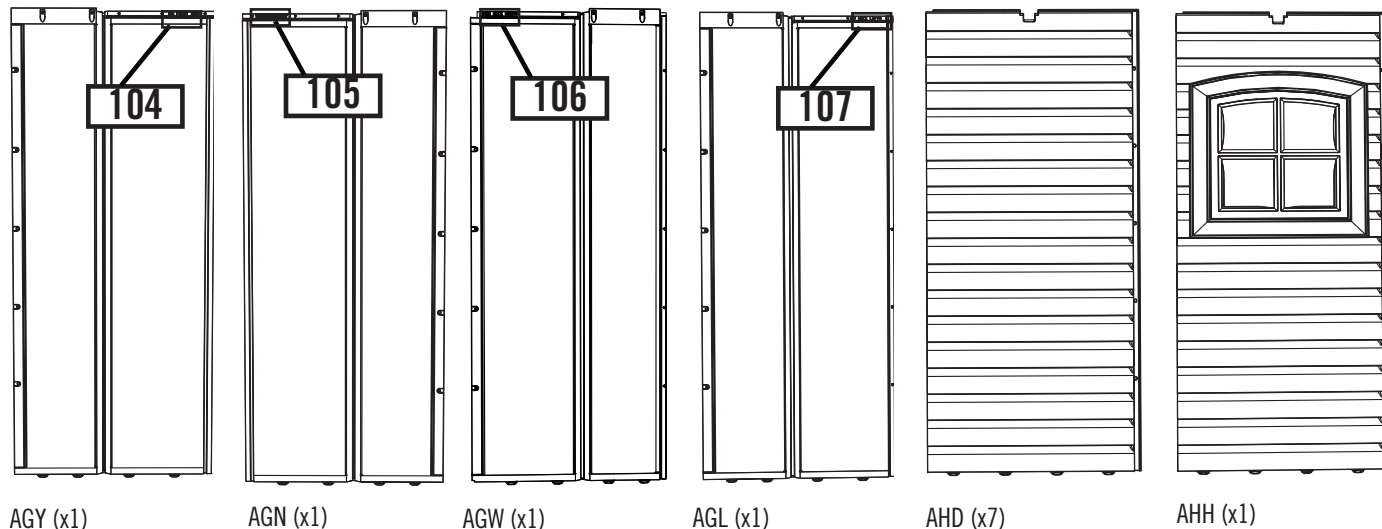

CONTENTS SMALL PARTS BOX / CONTENU DE LA BOÎTE DE PIÈCES EN MÉTAL / CONTENIDO DE LA CAJA DE PIEZAS PEQUEÑAS

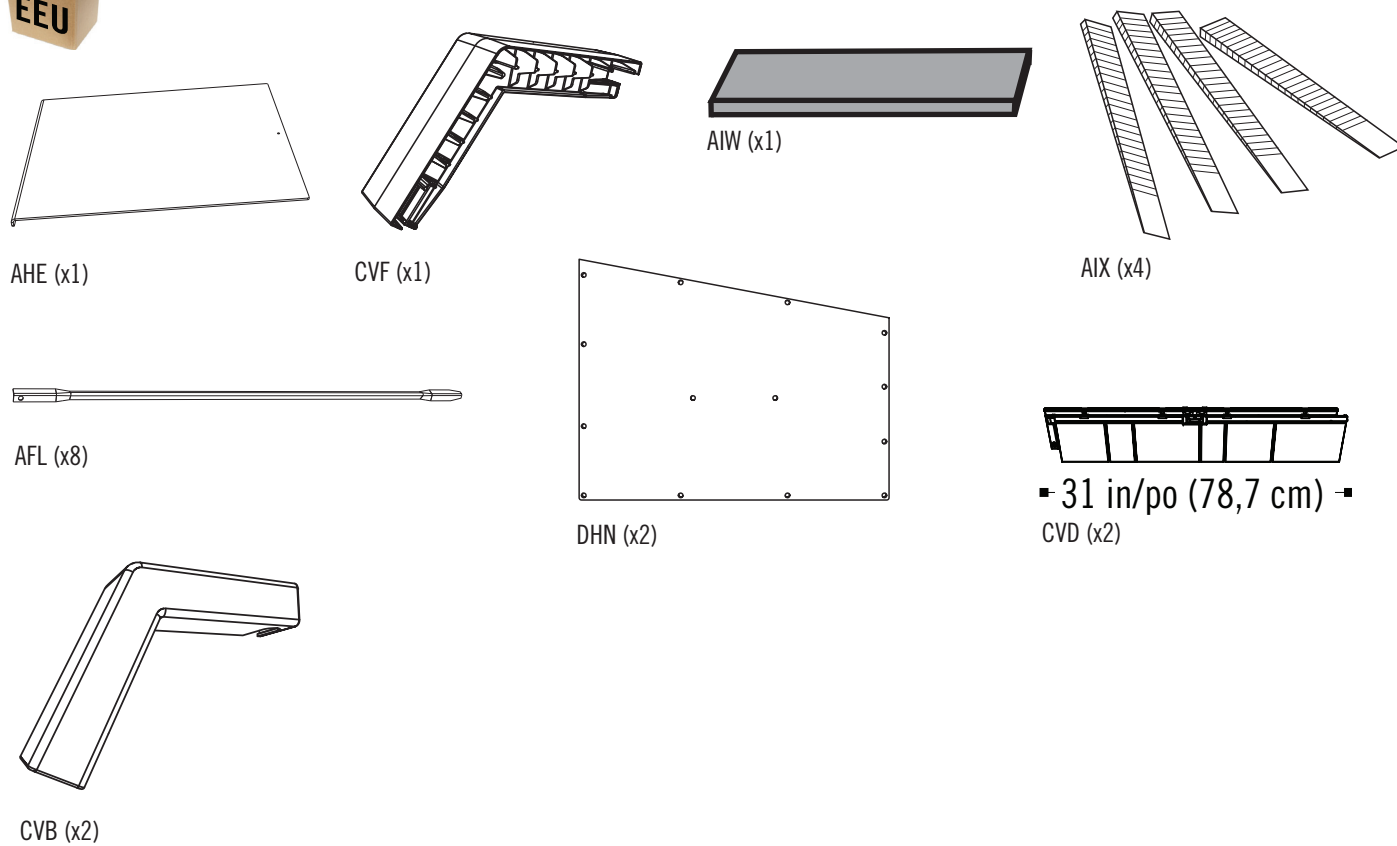

Remove this section for quick reference / Enlever cette section pour référence rapide / Retirar esta sección para referencia rápida



# PARTS IDENTIFIER / IDENTIFICATEUR DE PIÈCES / IDENTIFICADOR DE PIEZAS

HARDWARE BAGS / SACS DE QUINCAILLERIE / BOLSAS DE ELEMENTOS DE FIJACIÓN

*Remove this section for quick reference / Enlever cette section pour référence rapide / Retirar esta sección para referencia rápida*





## ► SECTION 8 (CONTINUED) / SECTION 8 (SUITE) / SECCIÓN 8 (CONTINUACIÓN)

TOOLS AND PARTS REQUIRED / OUTILS ET QUINCAILLERIE REQUIS / INSTRUMENTAL Y HERRAJE REQUERIDOS

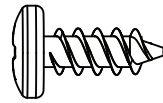

ADZ (x6)

### 8.2

- Insert the **Shelf Brackets (AIY)** into the slots in the Wall/Shelf Support Channels. **The Brackets must be at the same height.**
- Insérer les **équerres (AIY)** dans les fentes dans les canaux de support pour les murs/étagères. **Les équerres doivent être à la même hauteur.**
- Insertar las **escuadras (AIY)** en las ranuras en los canales de soporte para las paredes/estantes. **Las escuadras deben estar a la misma altura.**

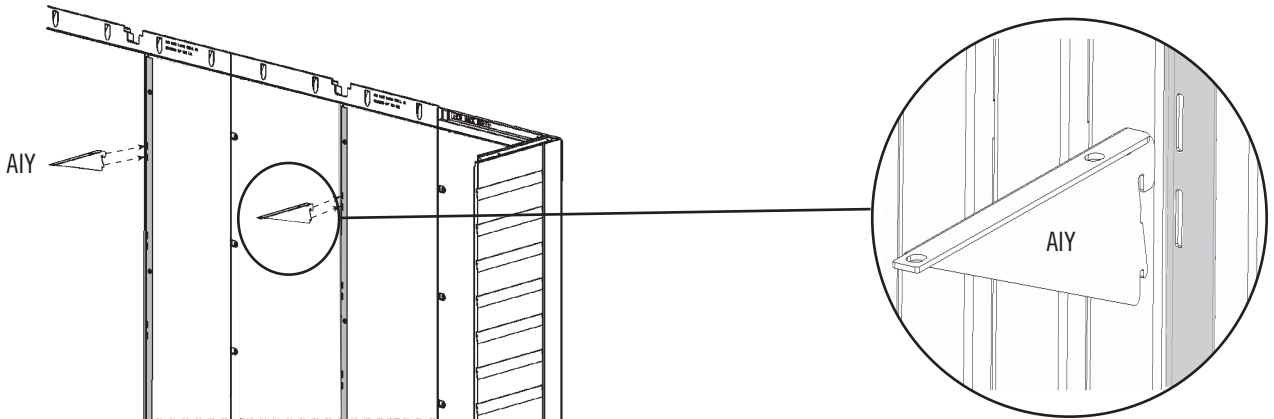

### 8.3

- Attach the **Shelf (AFV)** to the Corner Wall Panels and Shelf Brackets using six (6) **Screws (ADZ)**.
- Attacher l'**étagère (AFV)** aux panneaux angulaires et aux équerres à l'aide de six (6) **vis (ADZ)**.
- Sujete el **estante (AFV)** a los paneles angulares y las escuadras usando seis (6) **tornillos (ADZ)**.

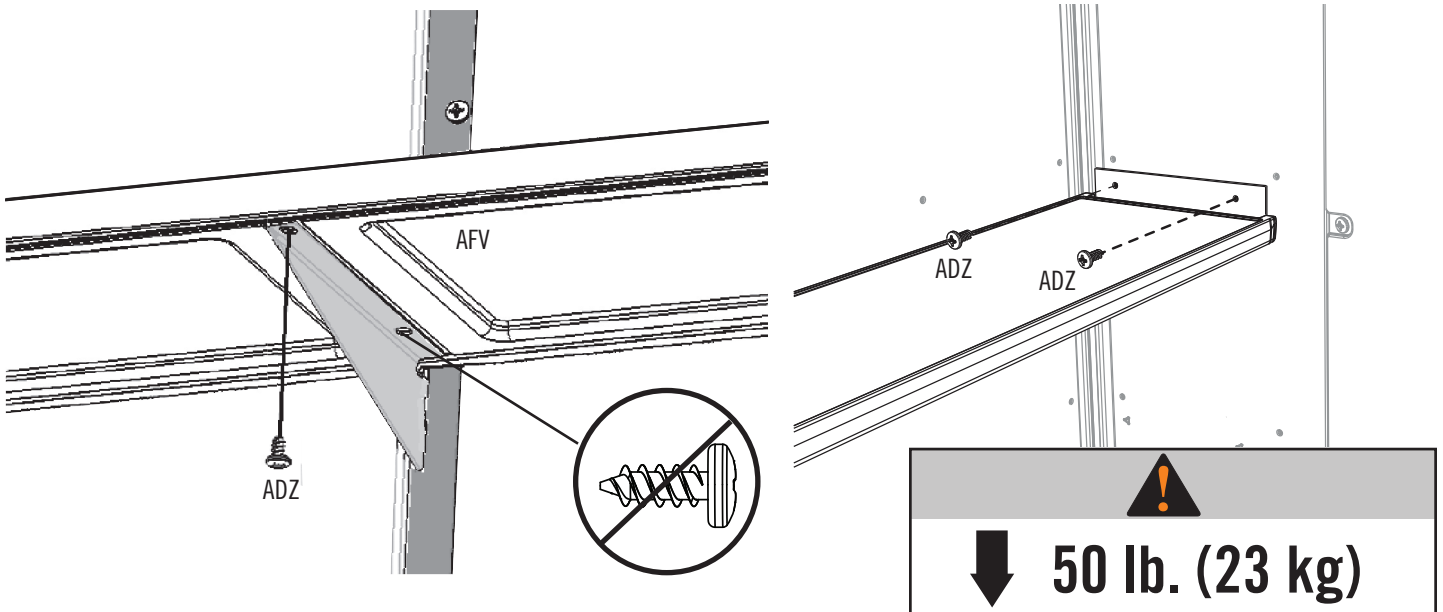

# 9

## DOOR & ENTRY GABLE INSTALLATION / INSTALLATION DU TOIT À PIGNON ET LES PORTES / INSTALACIÓN DE LA FACHADA DE ENTRADA Y LAS PUERTAS



### HARDWARE REQUIRED / QUINCAILLERIE REQUISE / HERRAJE REQUERIDO

Hardware Bag / Sac de quincaillerie / Bolsa de herraje

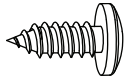

ADX (x4)



AHP (x2)

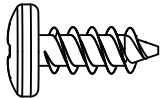

ADZ (x6)

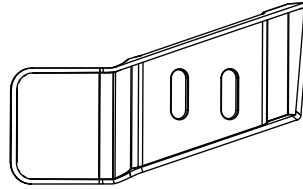

AIM (x1)

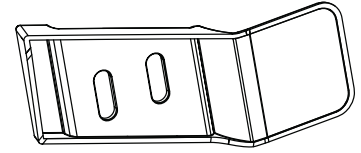

AIC (x1)



### PARTS REQUIRED / PIÈCES REQUISES / PIEZAS REQUERIDAS

Plastic Part / Pièce en plastique / Pieza de plástico

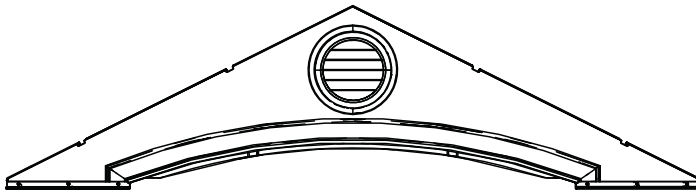

(x1)

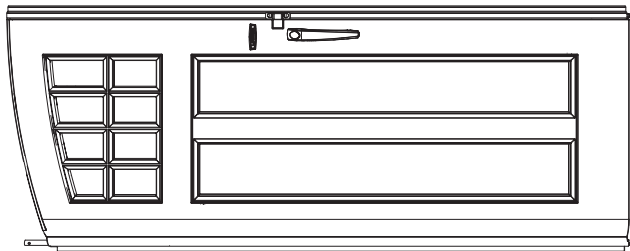

(x1)

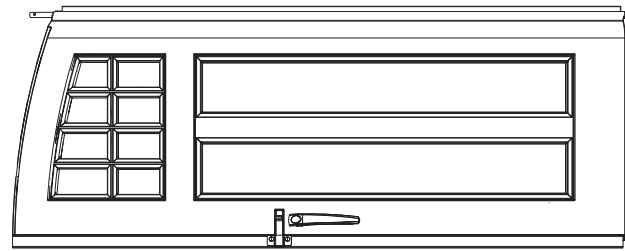

(x1)



### TOOLS REQUIRED / OUTILS REQUIS / INSTRUMENTAL REQUERIDO

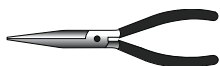

## ► SECTION 9 (CONTINUED) / SECTION 9 (SUITE) / SECCIÓN 9 (CONTINUACIÓN)

TOOLS AND HARDWARE REQUIRED / OUTILS ET QUINCAILLERIE REQUIS / INSTRUMENTAL Y HERRAJE REQUERIDOS



AHP (x1)



- If you have trouble with this section, follow the code below to view a how-to video on this section.
- En cas d'avoir problèmes avec l'assemblage dans cette section, suivre le code en bas pour voir un vidéo sur l'assemblage dans cette section.
- En caso de problemas con el ensamble en esta sección, seguir el código debajo para ver un video sobre el ensamble en esta sección.



<http://go.lifetime.com/8dginstall>

### 9.1



- Pull the Hinge Tube down out of the Door about six inches. Align the hole at the bottom of the Hinge Tube with the slit in the Bushing, and insert the Tube. Insert a **Cotter Pin (AHP)** and bend the ends.
- Étendre le tube d'articulation à peu près quinze centimètres du bord inférieur de la porte. Aligner le trou dans la partie inférieure du tube avec la fente dans la bague, et insérer le tube. Insérer une **clavette (AHP)**, et plier les extrémités.
- Extender el tubo de articulación unos quince centímetros del borde inferior de la puerta. Alinear el agujero en la parte inferior del tubo con la rendija en el casquillo, e insertar el tubo. Insertar una **clavija (AHP)** y doble los extremos.

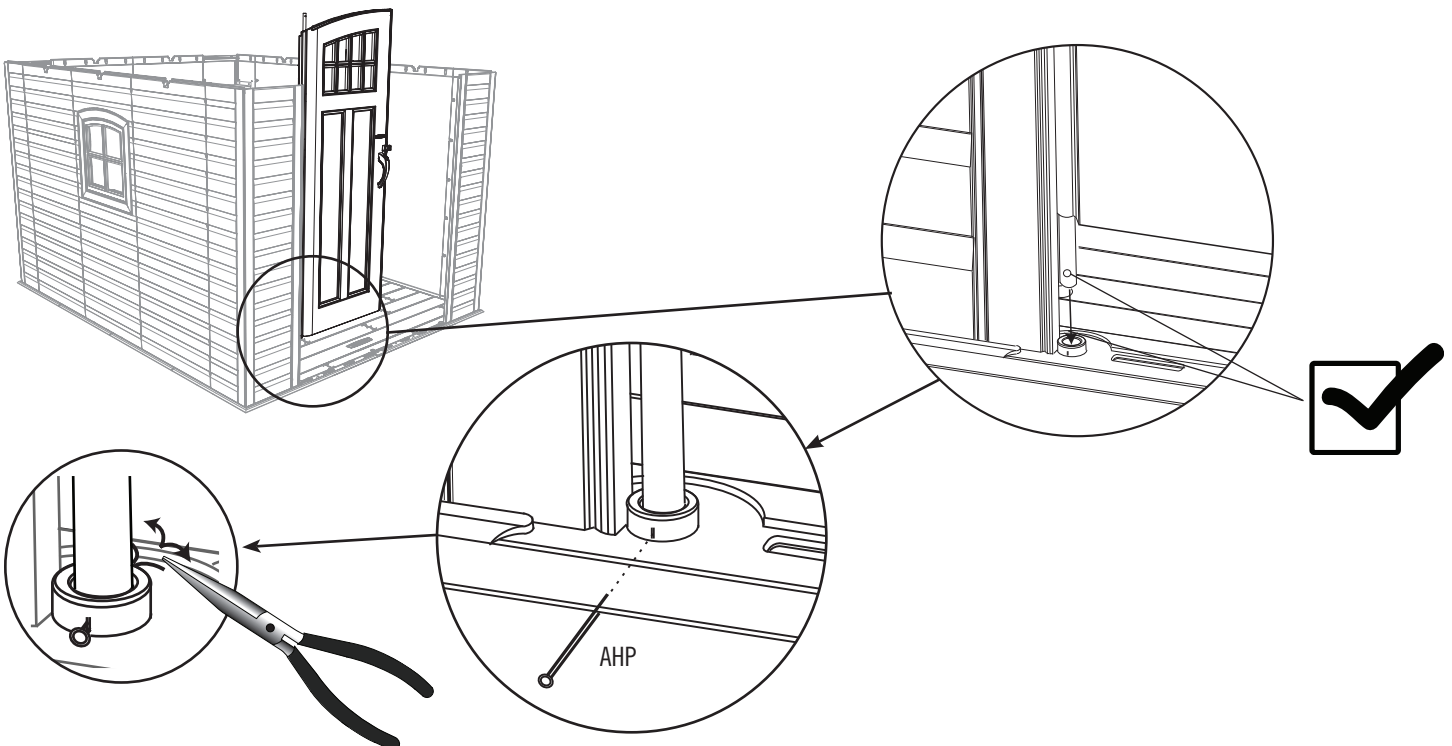

## ► SECTION 9 (CONTINUED) / SECTION 9 (SUITE) / SECCIÓN 9 (CONTINUACIÓN)

TOOLS AND HARDWARE REQUIRED / OUTILS ET QUINCAILLERIE REQUIS / INSTRUMENTAL Y HERRAJE REQUERIDOS

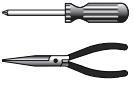

AHP (x1)

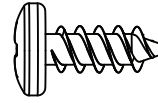

ADZ (x6)

### 9.2

- Repeat this step for the Right Door.
- Répéter cette étape pour la porte droite.
- Repetir este paso para la puerta derecha.

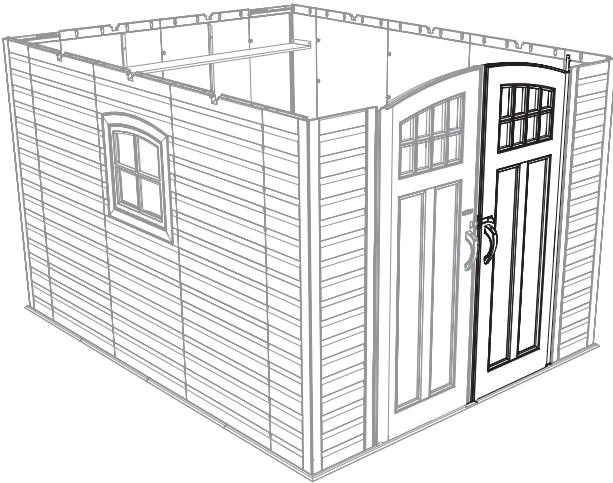

### 9.3

- Slide the holes in the Entry Gable down over the two Hinge Tubes.
- Faire glisser les trous dans le pignon d'entrée sur les deux tubes.
- Deslizar los agujeros en la fachada de entrada sobre los dos tubos.

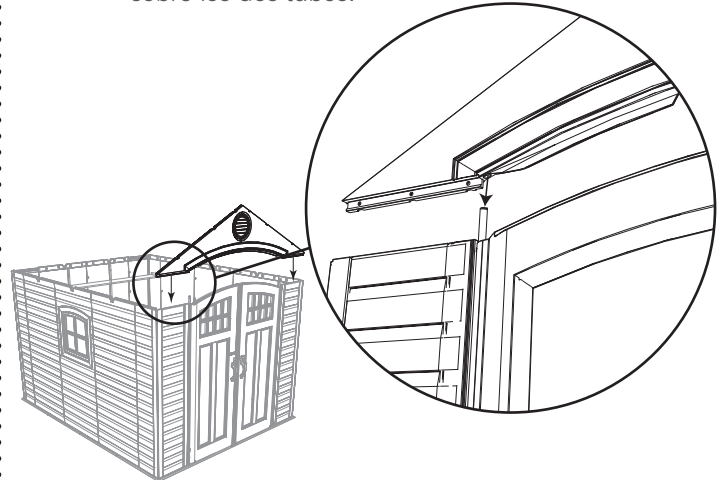

### 9.4

- Secure the Entry Gable to the Shed using six (6) Screws (ADZ).
- Fixer le pignon d'entrée à l'abri à l'aide de six (6) vis (ADZ).
- Fijar la fachada de entrada a la caseta usando seis (6) tornillos (ADZ).

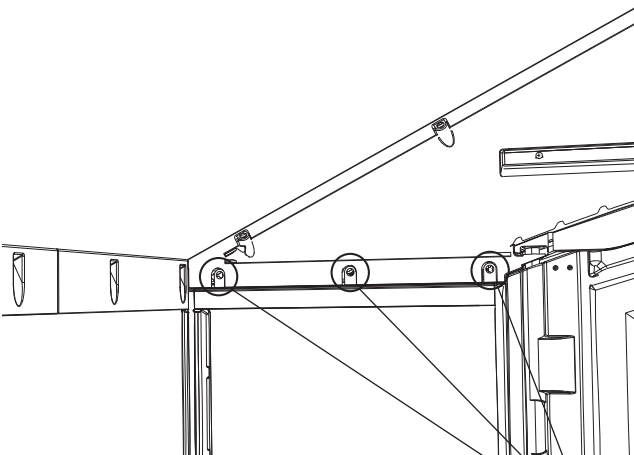

ADZ

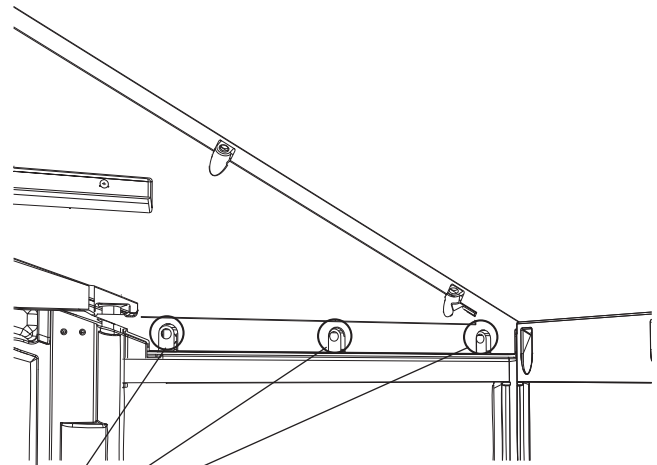

ADZ

## ► SECTION 9 (CONTINUED) / SECTION 9 (SUITE) / SECCIÓN 9 (CONTINUACIÓN)

TOOLS AND HARDWARE REQUIRED / OUTILS ET QUINCAILLERIE REQUIS / INSTRUMENTAL Y HERRAJE REQUERIDOS

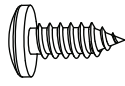

ADX (x4)

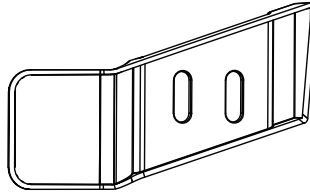

AIM (x1)

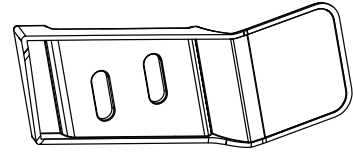

AIC (x1)

### 9.5

- Attach the **Left (AIC)** and **Right (AIM)** Gap Flaps to the corners of the Doors using the hardware provided. **These Flaps simply serve to block out light.**
- Fixer les **rabats gauche (AIC)** et **droit (AIM)** aux portes à l'aide de la quincaillerie incluse. **Ces rabats ne servent qu'à empêcher la lumière d'entrer.**
- Fijar las **tapas de las puertas izquierda (AIC)** y **derecha (AIM)** a las puertas usando el herraje incluido. **Estas tapas sirven sólo para tapar la luz.**

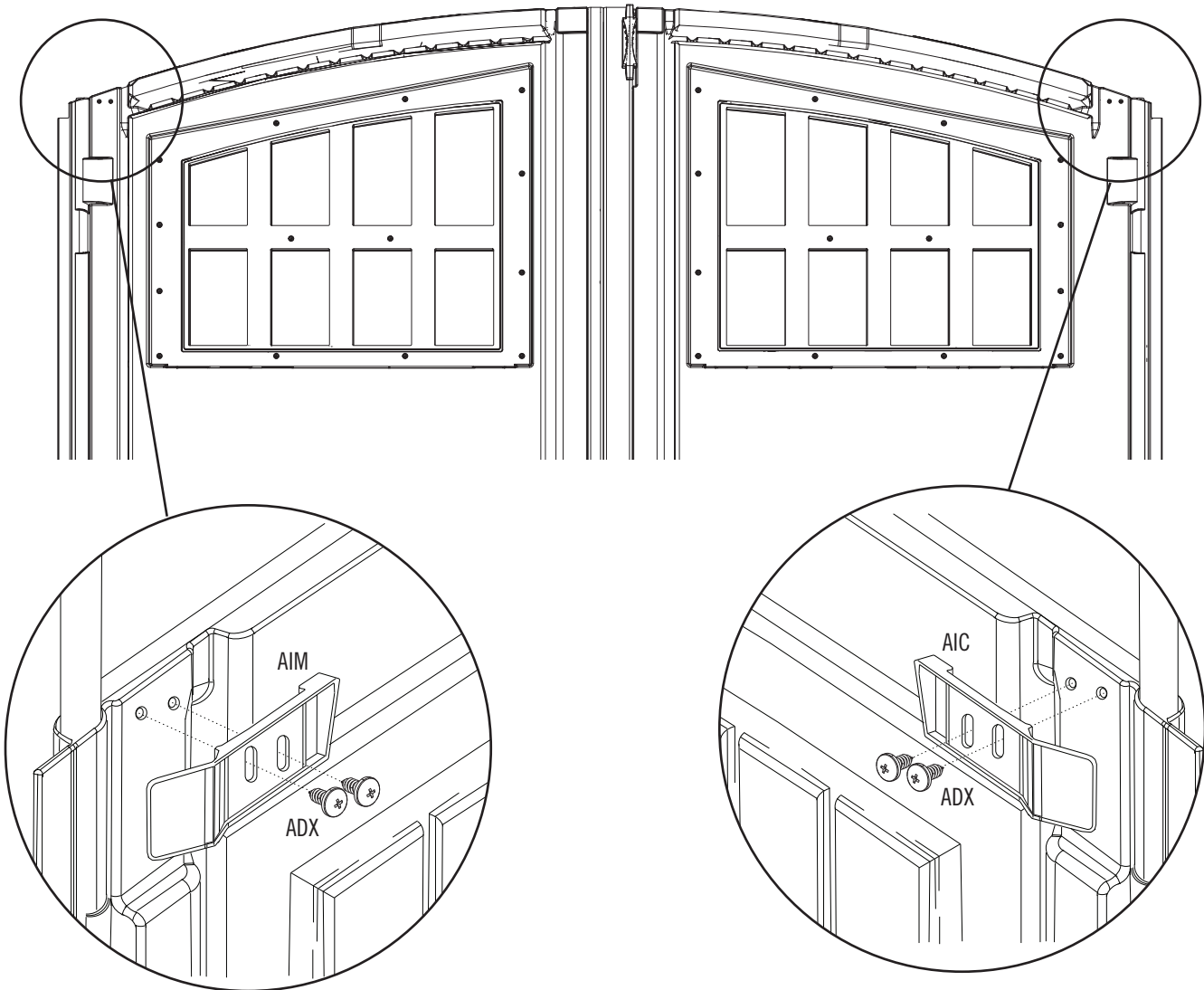



### HARDWARE REQUIRED / QUINCAILLERIE REQUISE / HERRAJE REQUERIDO

Hardware Bag / Sac de quincaillerie / Bolsa de herraje

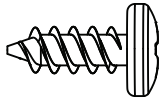

ADZ (x155)

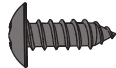

CWU (x24)

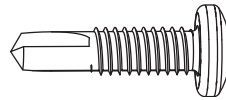

CUZ (x4)

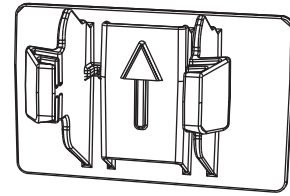

AXX (x2)



### PARTS REQUIRED / PIÈCES REQUISES / PIEZAS REQUERIDAS

Metal Parts / Pièces en métal / Piezas de metal



AFL (x8)

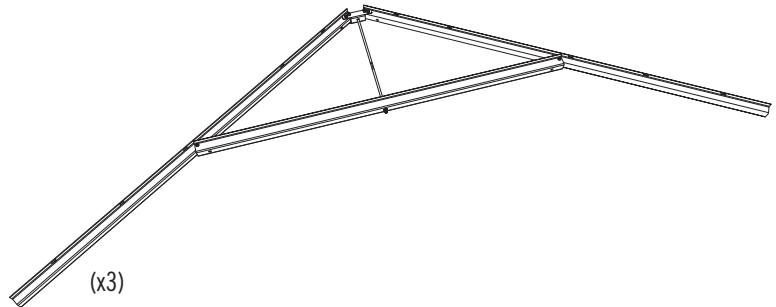

Plastic Parts / Pièces en plastique / Piezas de plástico

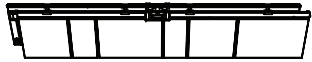

■ 31 in/po (78,7 cm) ■

CVD (x2)



— 45 1/2 in/po (1,16 m) —

CVE (x2)

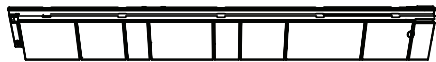

— 45 1/2 in/po (1,16 m) —

CVC (x2)



CVF (x1)

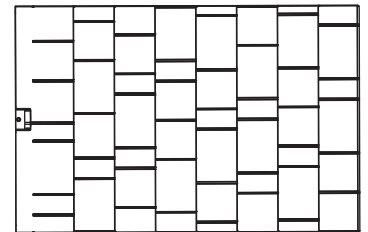

AGQ (x8)



CVG (x4)

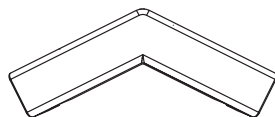
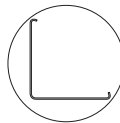

CVB (x2)

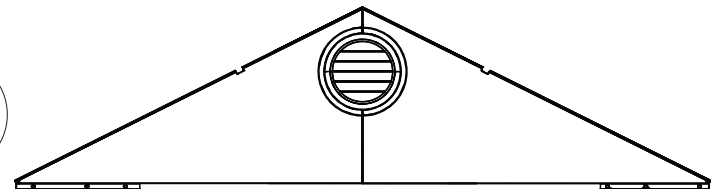

(x1)

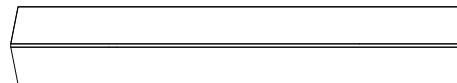

CVA (x2)



### TOOLS REQUIRED / OUTILS REQUIS / INSTRUMENTAL REQUERIDO

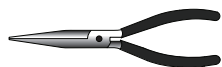



## ► SECTION 10 (CONTINUED) / SECTION 10 (SUITE) / SECCIÓN 10 (CONTINUACIÓN)

TOOLS AND HARDWARE REQUIRED / OUTILS ET QUINCAILLERIE REQUIS / INSTRUMENTAL Y HERRAJE REQUERIDOS

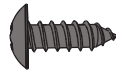

CWU (x24)

### 10.1



- You can make it easier to install the **Corner Trim (CVG)** pieces by flattening the spine along the length of the Trim before installation.
- C'est plus facile installer les **moules (CVG)** par aplanir le dos le long des pièces avant de l'installation.
- Se puede facilitar la instalación de las **molduras (CVG)** por aplanar el espino a lo largo de las piezas de ribete antes de instalarlas.

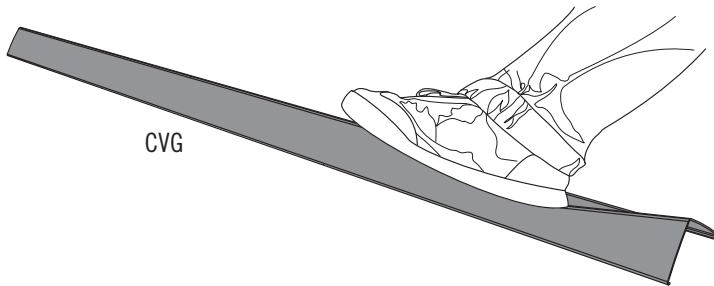

CVG

### 10.2

- Attach a **Corner Trim (CVG)** to each corner with six (6) **Screws (CWU)**—two at the top, two in the middle, and two at the bottom. **Repeat for the other corners.**
- Attacher une **moulure (CVG)** à chaque coin à l'aide des six (6) **vis (CWU)** — deux à la partie supérieure, deux dans le centre, et deux à la partie inférieure. **Répéter pour les autres coins.**
- Sujetar una **moldura (CVG)** a cada esquina usando seis (6) **tornillos (CWU)**, dos en la parte superior, dos en el centro, y dos a la parte inferior. **Repetir para las otras esquinas.**

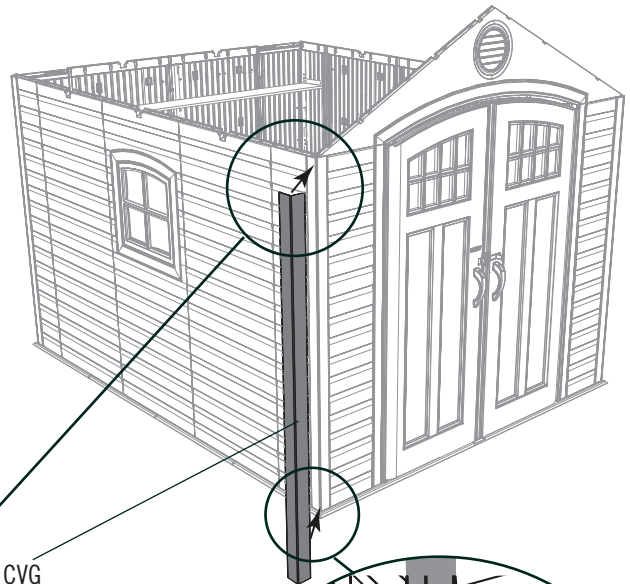

CVG

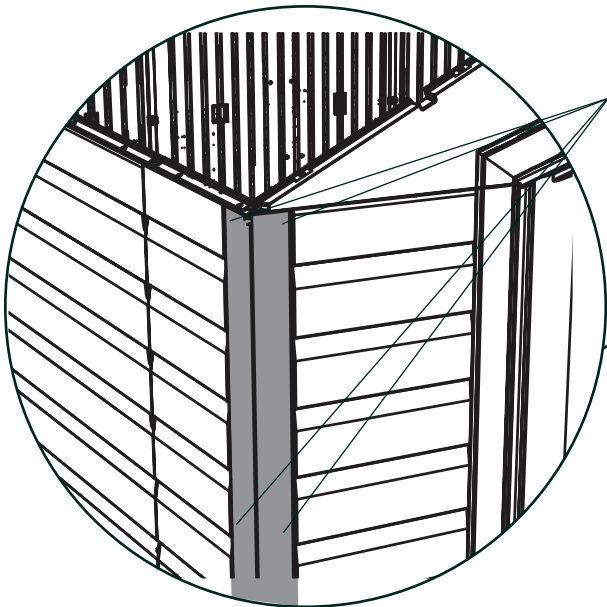

CWU (x4)

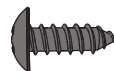

CWU (x2)

## ► SECTION 10 (CONTINUED) / SECTION 10 (SUITE) / SECCIÓN 10 (CONTINUACIÓN)

TOOLS AND HARDWARE REQUIRED / OUTILS ET QUINCAILLERIE REQUIS / INSTRUMENTAL Y HERRAJE REQUERIDOS



### 10.3

- Set a Truss Assembly into the notches on the first two opposite Wall Panels. Set a **Roof Panel (AGQ)** onto the Gable, Wall Panel, and Truss Assembly.
- Mettre une Ferme dans les encoches des premiers deux panneaux muraux opposés. Mettre un **panneaux de toit (AGQ)** sur le pignon, panneau mural, et la ferme.
- Colocar una cercha dentro de las muescas de los primeros dos paneles de pared opuestos. Colocar un **panel de tejado (AGQ)** sobre la fachada de entrada, panel mural, y la cercha.

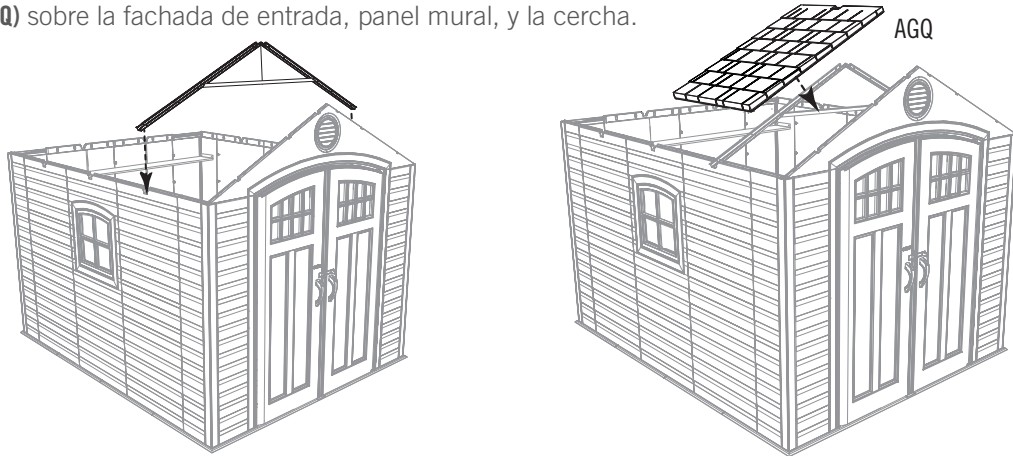

### 10.4

- The groove at the bottom of the Roof Panel sets over the top of the Wall Panel. Ensure the alignment nub fits into the notch in the Truss.
- Mettre la rainure au bord inférieur du panneau de toit sur la partie supérieure du panneau mural. Mettre la petite bosse d'alignement dans l'encoche de la ferme.
- Colocar la ranura a lo largo del borde inferior del panel de tejado sobre la parte superior del panel de pared. Encajar el bulbo de alineamiento en la muesca en la cercha.

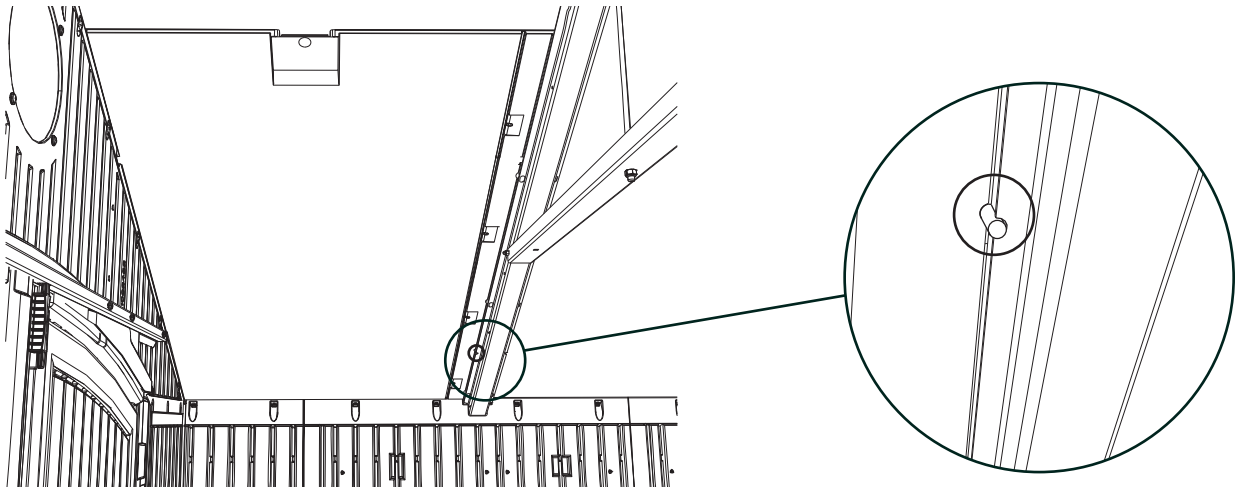

## ► SECTION 10 (CONTINUED) / SECTION 10 (SUITE) / SECCIÓN 10 (CONTINUACIÓN)

TOOLS AND HARDWARE REQUIRED / OUTILS ET QUINCAILLERIE REQUIS / INSTRUMENTAL Y HERRAJE REQUERIDOS

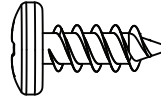

ADZ (x4)

### 10.5

- Align the four holes in the Wall Panel with those at the bottom of the Roof Panel, and insert four (4) **Screws (ADZ)** to secure the Panel in place.
- Aligner les quatre trous dans le panneau mural avec ceux au bord inférieur du panneau de toit, et insérer quatre (4) **vis (ADZ)** pour attacher le panneau en place.
- Alinear los cuatro agujeros en el panel de pared con los al borde inferior del panel de tejado, e insertar cuatro (4) **tornillos (ADZ)** para sujetarlo en su lugar.

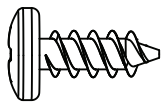
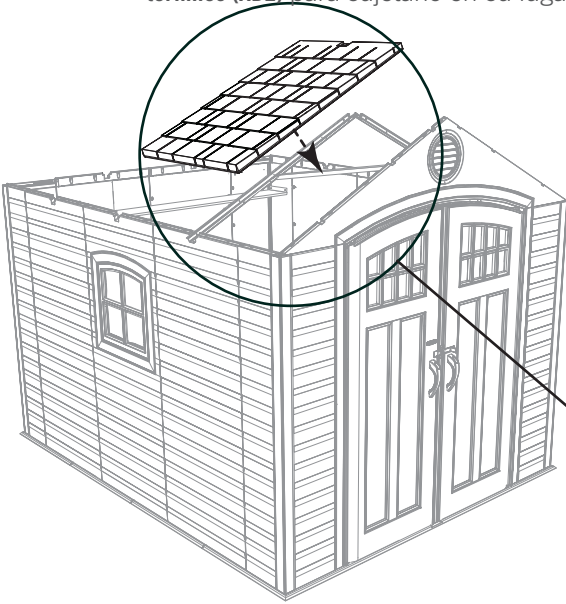

ADZ (x4)

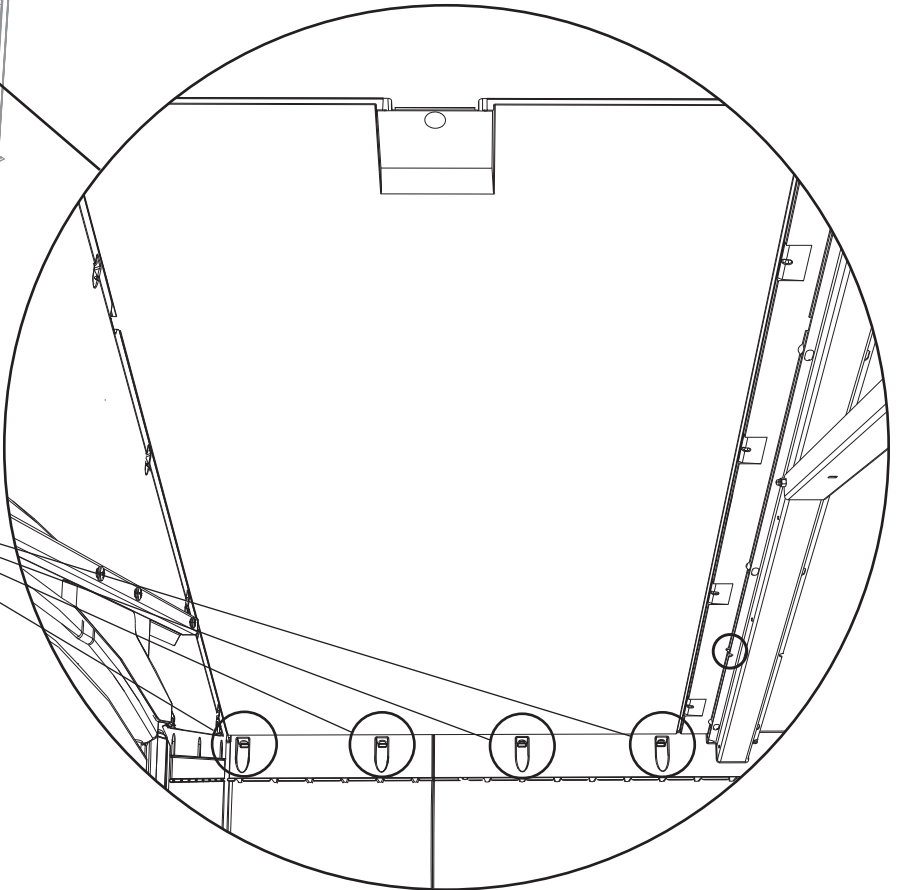

## ► SECTION 10 (CONTINUED) / SECTION 10 (SUITE) / SECCIÓN 10 (CONTINUACIÓN)

TOOLS AND HARDWARE REQUIRED / OUTILS ET QUINCAILLERIE REQUIS / INSTRUMENTAL Y HERRAJE REQUERIDOS

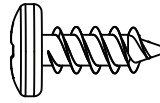

ADZ (x4)

### 10.6

- Insert the first two **Screws (ADZ)** through the Gable and into the Roof Panel and the first two **Screws (ADZ)** through the Truss and the Roof Panel at the locations indicated.
- Insérer les premières deux **vis (ADZ)** à travers le pignon et dans le panneau de toit et les premières deux **vis (ADZ)** à travers la ferme et dans le panneau de toit aux emplacements indiqués.
- Insertar los primeros dos **tornillos (ADZ)** por la fachada y dentro del panel de tejado y los primeros dos tornillos (ADZ) por la cercha y dentro del panel de tejado a las ubicaciones indicadas.

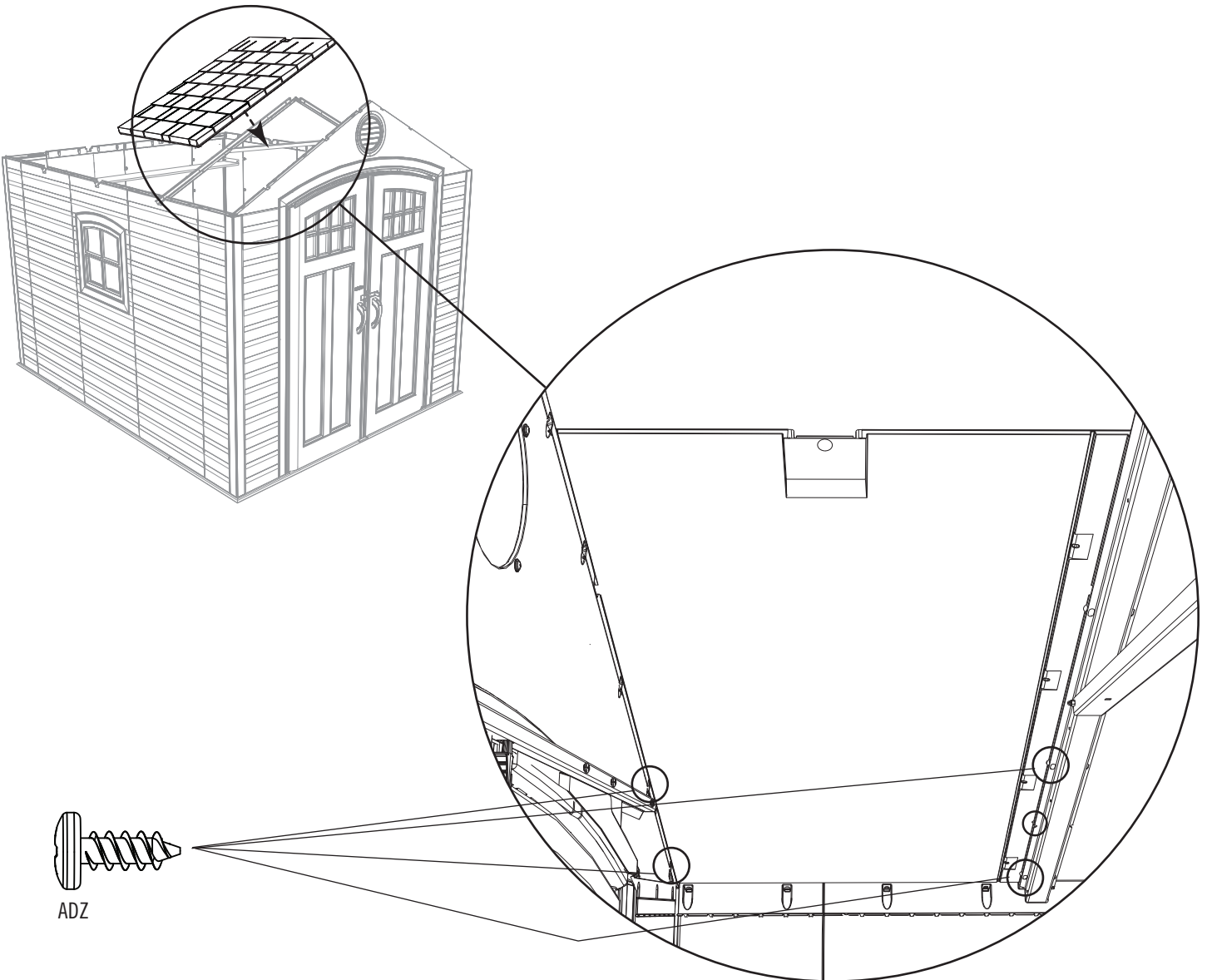

## ► SECTION 10 (CONTINUED) / SECTION 10 (SUITE) / SECCIÓN 10 (CONTINUACIÓN)

TOOLS AND HARDWARE REQUIRED / OUTILS ET QUINCAILLERIE REQUIS / INSTRUMENTAL Y HERRAJE REQUERIDOS

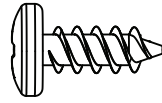

ADZ (x14)

### 10.7

- Insert the **Roof Support (AFL)** into the notches in the Gable and between the Truss and the Roof Panel. Insert three (3) more **Screws (ADZ)** to secure the Panel in place.
- Mettre le **support de toit (AFL)** dans les encoches dans le pignon et entre le panneau de toit et la ferme. Insérer trois (3) autres **vis (ADZ)** pour attacher le panneau en place.
- Insertar el **soporte de tejado (AFL)** en las muescas en la fachada y entre la cercha y el panel de tejado. Insertar tres (3) **tornillos (ADZ)** más para sujetar el panel en su lugar.

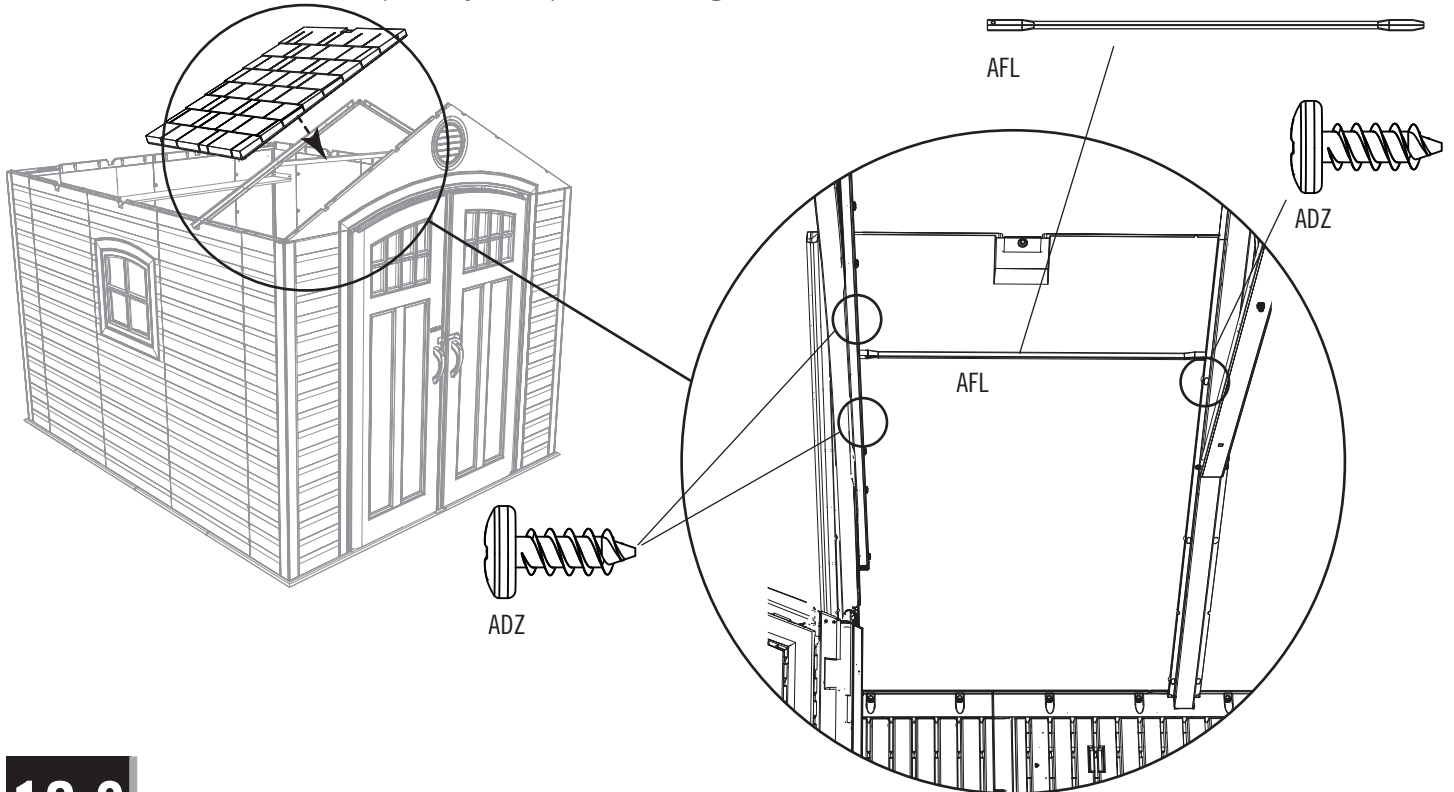

### 10.8

- Repeat steps 10.4–10.7 for the second front Roof Panel.
- Répéter les étapes 10.4 – 10.7 pour le deuxième panneau de toit avant.
- Repetir los pasos 10.4–10.7 para el segundo panel de tejado delantero.

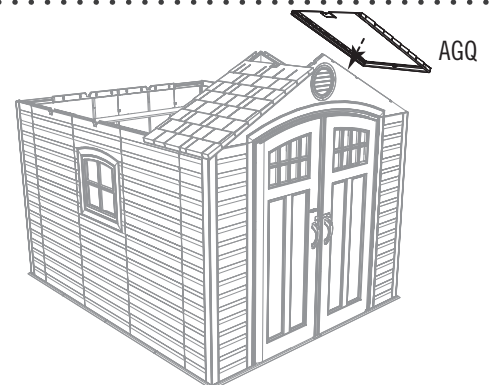



## ► SECTION 10 (CONTINUED) / SECTION 10 (SUITE) / SECCIÓN 10 (CONTINUACIÓN)

TOOLS AND HARDWARE REQUIRED / OUTILS ET QUINCAILLERIE REQUIS / INSTRUMENTAL Y HERRAJE REQUERIDOS

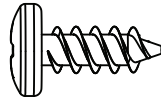

ADZ (x40)

**10.9**

- Repeat the previous steps for the center Roof Panels.
- Répéter les étapes précédentes pour les panneaux de toit centraux.
- Repetir los pasos anteriores para los paneles de tejado centrales.



AFL (x4)

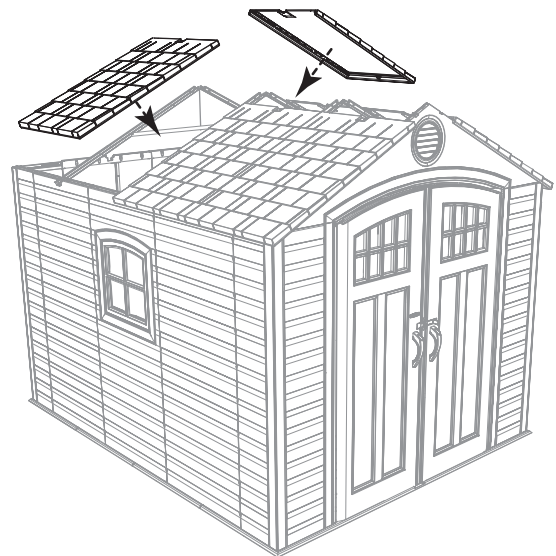
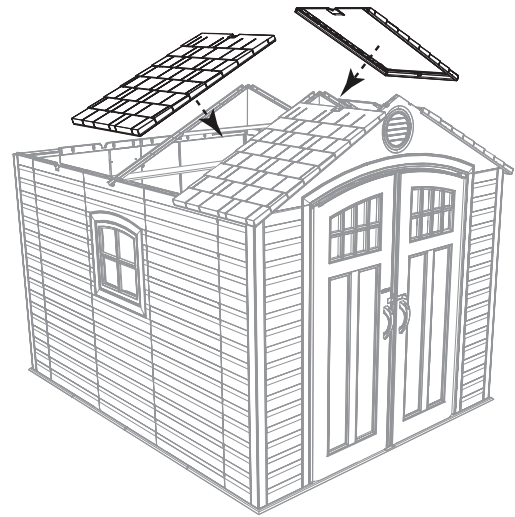
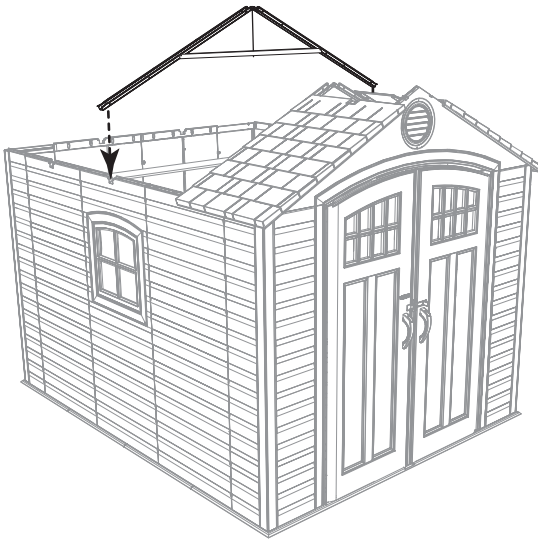

## ► SECTION 10 (CONTINUED) / SECTION 10 (SUITE) / SECCIÓN 10 (CONTINUACIÓN)

TOOLS AND HARDWARE REQUIRED / OUTILS ET QUINCAILLERIE REQUIS / INSTRUMENTAL Y HERRAJE REQUERIDOS

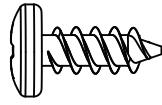

ADZ (x36)

### 10.10

- Attach the Rear Gable to the Shed using fourteen (14) **Screws (ADZ)**.
- Attacher le pignon arrière à l'abri à l'aide de quatorze (14) **vis (ADZ)**.
- Sujetar la fachada trasera a la caseta usando catorce (14) **tornillos (ADZ)**.

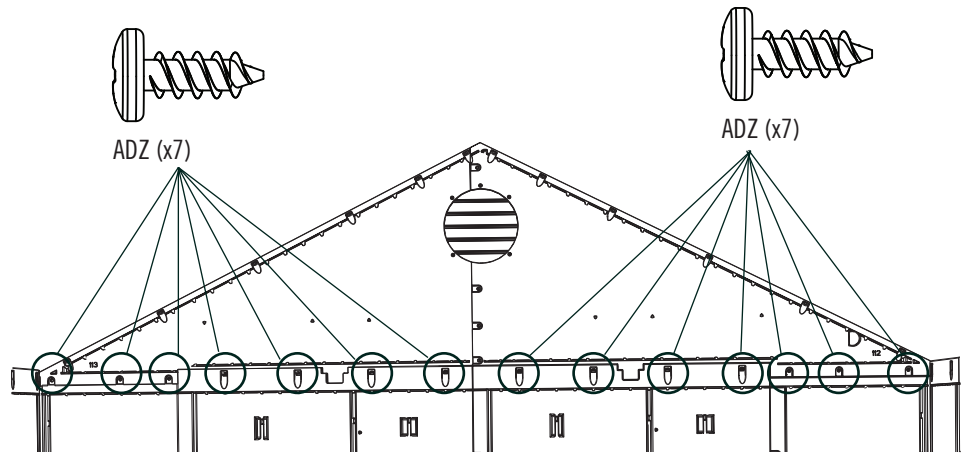
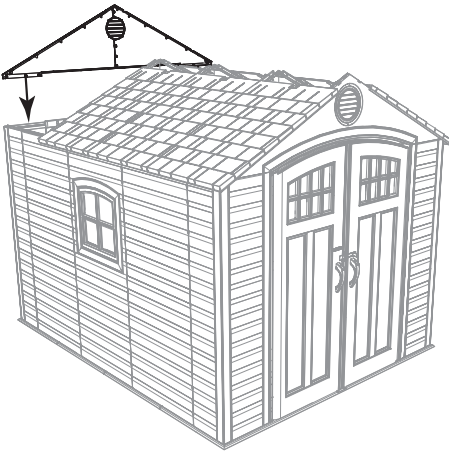

### 10.11

- Attach the last two Roof Panels to the Shed in the same way you did the first two.
- Attacher les derniers deux panneaux de toit à l'abri dans la même façon que les premiers deux.
- Sujetar los últimos dos paneles de tejado a la caseta en la misma manera que los primeros dos.

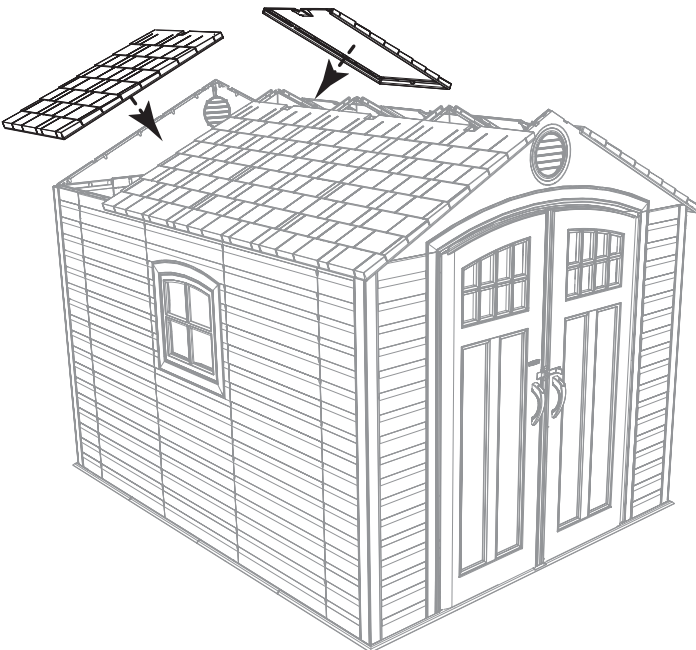

AFL (x2)



## ► SECTION 10 (CONTINUED) / SECTION 10 (SUITE) / SECCIÓN 10 (CONTINUACIÓN)

TOOLS AND HARDWARE REQUIRED / OUTILS ET QUINCAILLERIE REQUIS / INSTRUMENTAL Y HERRAJE REQUERIDOS



### 10.12

- Insert the two **Center Roof Extension Panels (CVD)** into the **Connector (CVF)** as shown.
- Insérer les deux **panneaux supplémentaires centraux de toit (CVD)** dans le **connecteur (CVF)** comme indiqué.
- Insertar los dos **extensiones centrales de los paneles de tejado (CVD)** en el **conector (CVF)** como se muestra.

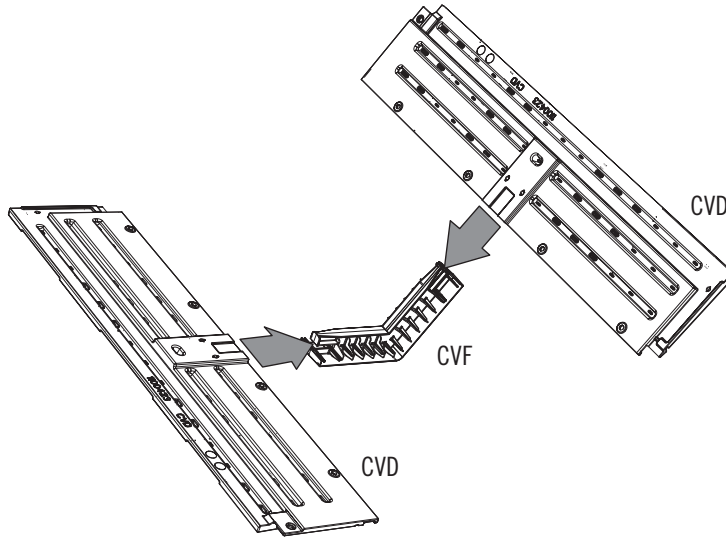

### 10.13

- Insert the ends of the two **Skylights (CVA)** into the **Connector (CVF)** as shown.
- Insérer les extrémités des deux **lucarnes (CVA)** dans le **connecteur (CVF)** comme indiqué.
- Insertar los extremos de los dos **tragaluces (CVA)** en el **conector (CVF)** como se muestra.

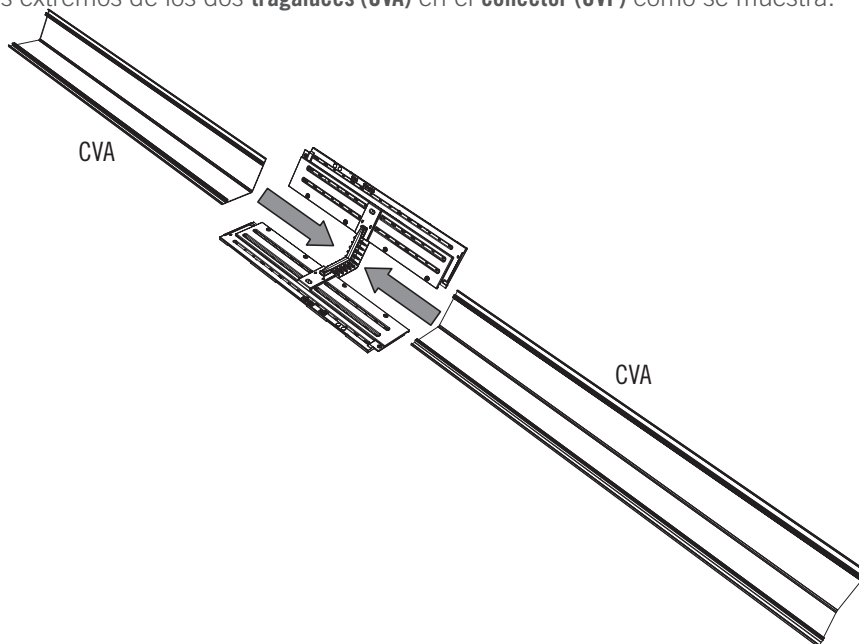

## ► SECTION 10 (CONTINUED) / SECTION 10 (SUITE) / SECCIÓN 10 (CONTINUACIÓN)

TOOLS AND HARDWARE REQUIRED / OUTILS ET QUINCAILLERIE REQUIS / INSTRUMENTAL Y HERRAJE REQUERIDOS

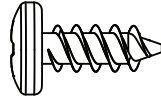

ADZ (x4)

### 10.14

- Secure the Skylights to the Extensions only at the points shown.
- Attacher les lucarnes aux panneaux supplémentaires aux points indiqués.
- Sujetar los tragaluces a las extensiones sólo a los puntos indicados.

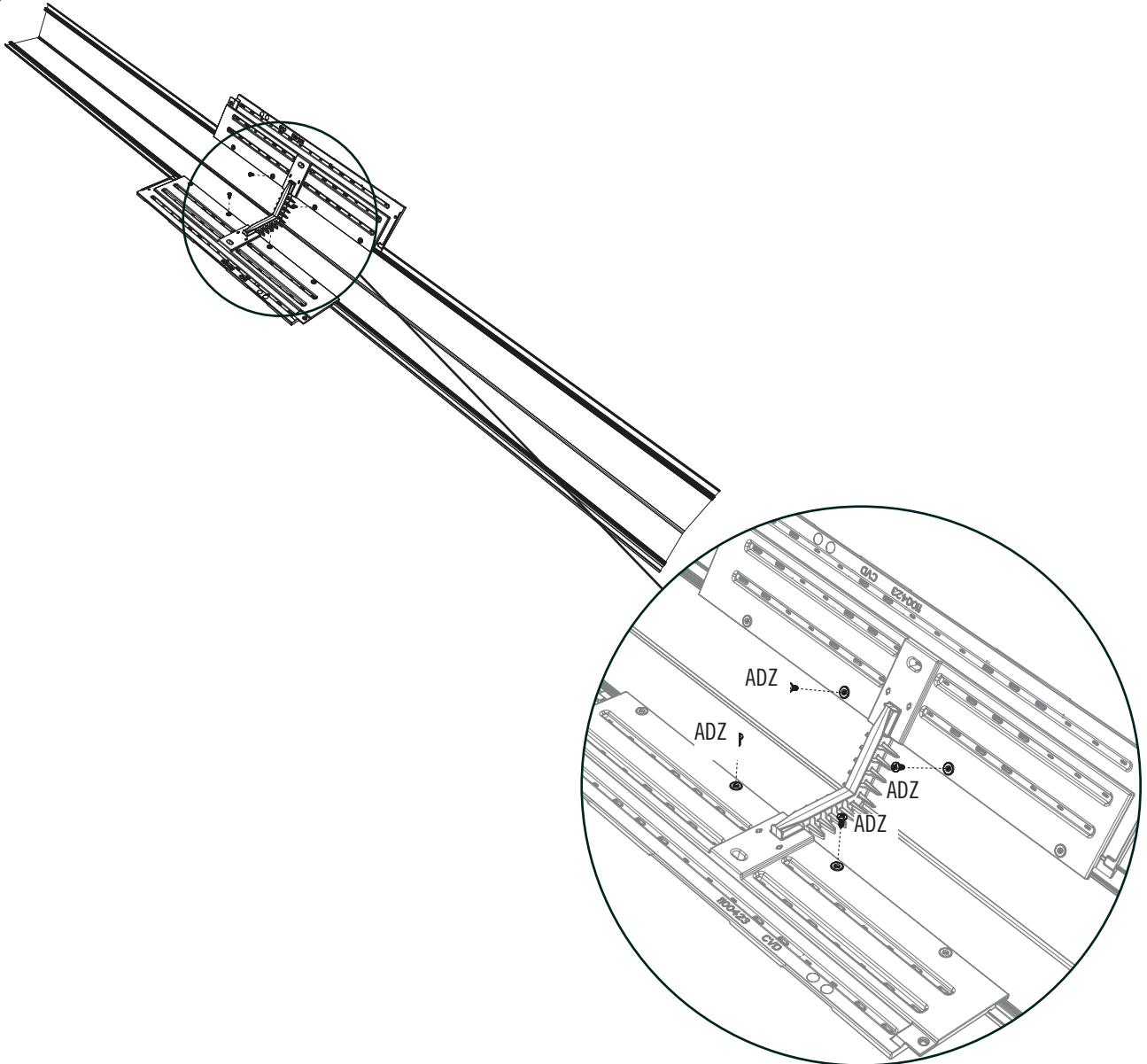

## ► SECTION 10 (CONTINUED) / SECTION 10 (SUITE) / SECCIÓN 10 (CONTINUACIÓN)

TOOLS AND HARDWARE REQUIRED / OUTILS ET QUINCAILLERIE REQUIS / INSTRUMENTAL Y HERRAJE REQUERIDOS

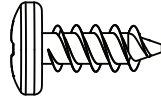

ADZ (x8)

### 10.15



- Set the Connector down inside the Center Truss. Secure the Skylights to the Extensions only at the eight points shown.
- Mettre le connecteur dedans la ferme centrale. Attacher les lucarnes aux panneaux supplémentaires aux huit points indiqués.
- Colocar el conector dentro de la cercha central. Sujetar los tragaluces a las extensiones sólo a los ocho puntos indicados.

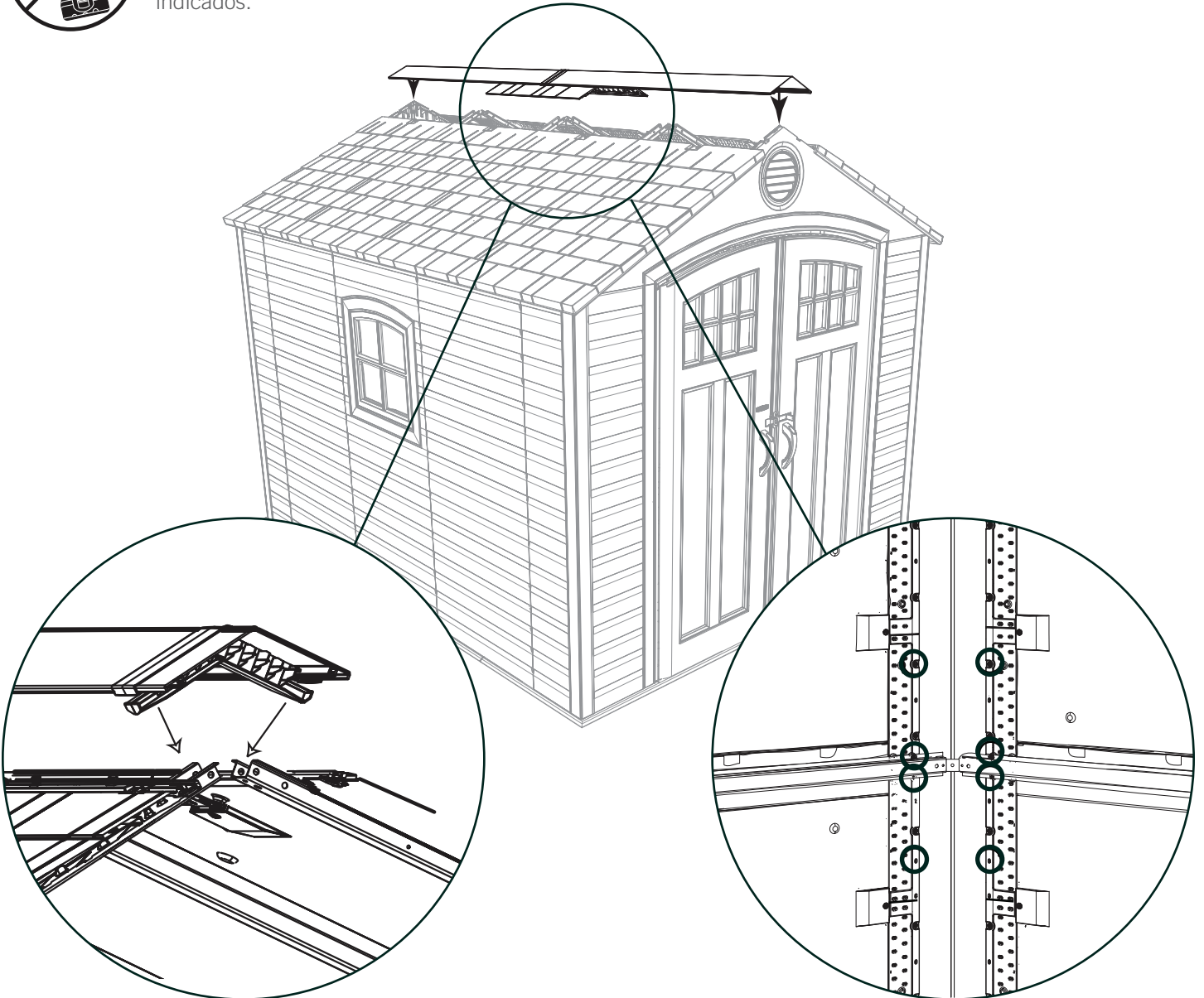

## ► SECTION 10 (CONTINUED) / SECTION 10 (SUITE) / SECCIÓN 10 (CONTINUACIÓN)

TOOLS AND HARDWARE REQUIRED / OUTILS ET QUINCAILLERIE REQUIS / INSTRUMENTAL Y HERRAJE REQUERIDOS

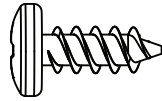

ADZ (x18)

### 10.16



- Slide the **Roof Panel Extensions (CVC & CVE)** underneath the Skylights. Connect them to the Skylights and other Roof Panels at the locations shown. The ends of the Panels overlap one another.
- Faire glisser les **panneaux supplémentaires latéraux (CVC et CVE)** sous les lucarnes. Les attacher aux lucarnes et les autres panneaux de toit aux emplacements indiqués. Les extrémités des panneaux se chevauchent.
- Deslizar las **extensiones de los paneles de pared (CVC y CVE)** debajo los tragaluces. Sujetarlos a los tragaluces y los otros paneles de tejado a las ubicaciones indicados. **Los extremos de los paneles se solapan.**

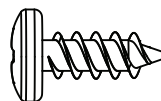
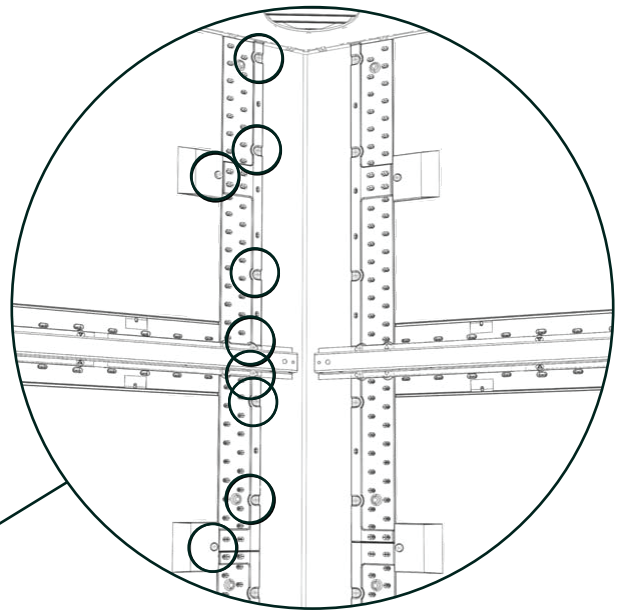
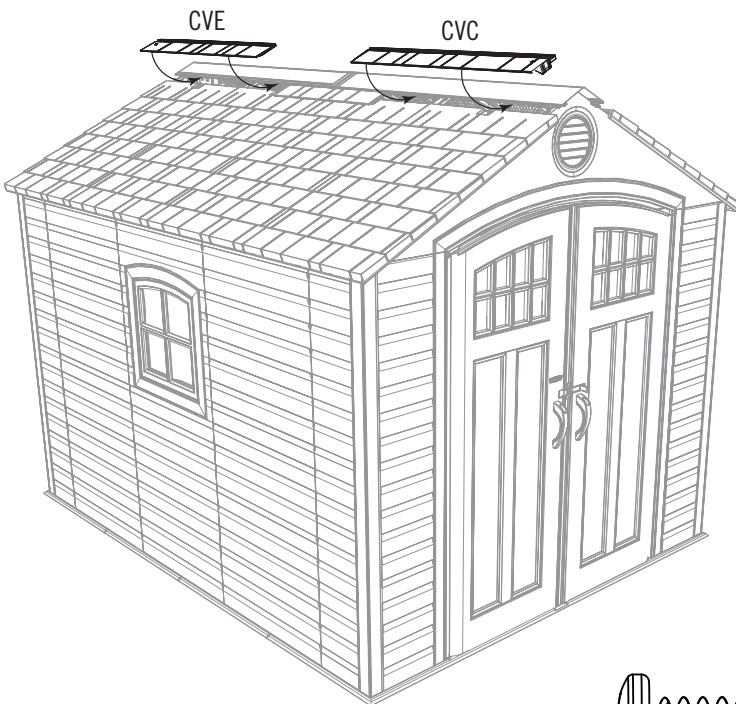

ADZ (x9)

## ► SECTION 10 (CONTINUED) / SECTION 10 (SUITE) / SECCIÓN 10 (CONTINUACIÓN)

TOOLS AND HARDWARE REQUIRED / OUTILS ET QUINCAILLERIE REQUIS / INSTRUMENTAL Y HERRAJE REQUERIDOS

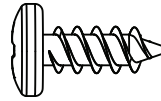

ADZ (x18)

### 10.17

- Repeat the previous steps for the other side of the shed.
- Répéter les étapes précédentes pour l'autre côté de l'abri.
- Repetir los pasos anteriores para el otro lado de la caseta.

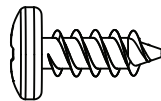
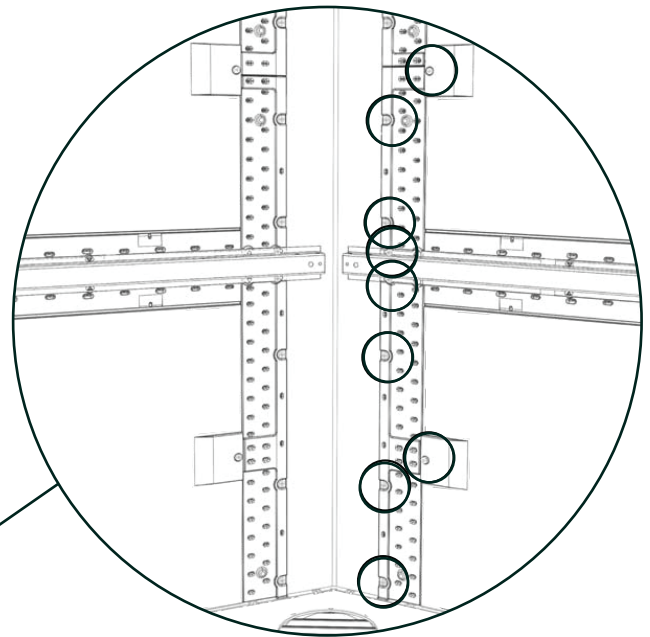
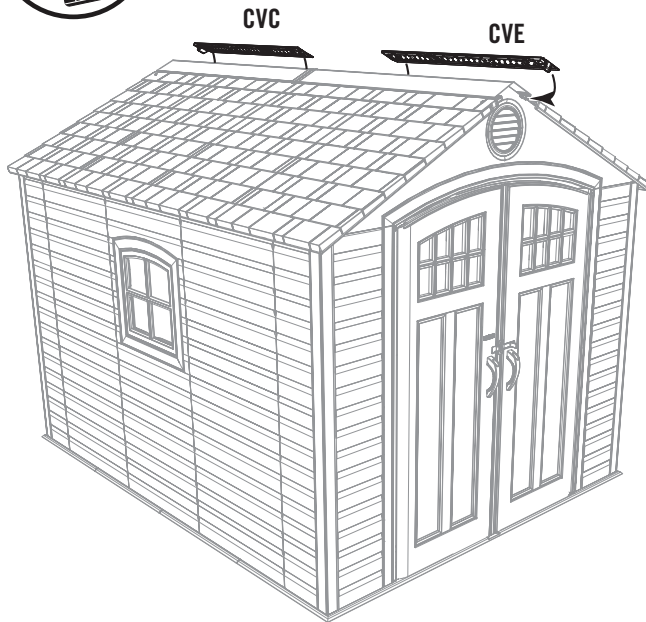

ADZ (x9)

## ► SECTION 10 (CONTINUED) / SECTION 10 (SUITE) / SECCIÓN 10 (CONTINUACIÓN)

TOOLS AND HARDWARE REQUIRED / OUTILS ET QUINCAILLERIE REQUIS / INSTRUMENTAL Y HERRAJE REQUERIDOS

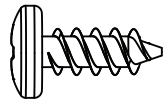

ADZ (x4)

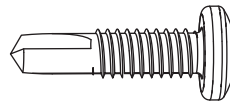

CUZ (x4)

### 10.18

- Attach an **End Cap (CVB)** at each end, and secure at the locations shown.
- Mettre un **Capuchon (CVB)** a chaque côté, et les attacher aux emplacements indiqués.
- Colocar un **tapón (CVB)** a cada extremo, y sujetarlos a las ubicaciones indicadas.

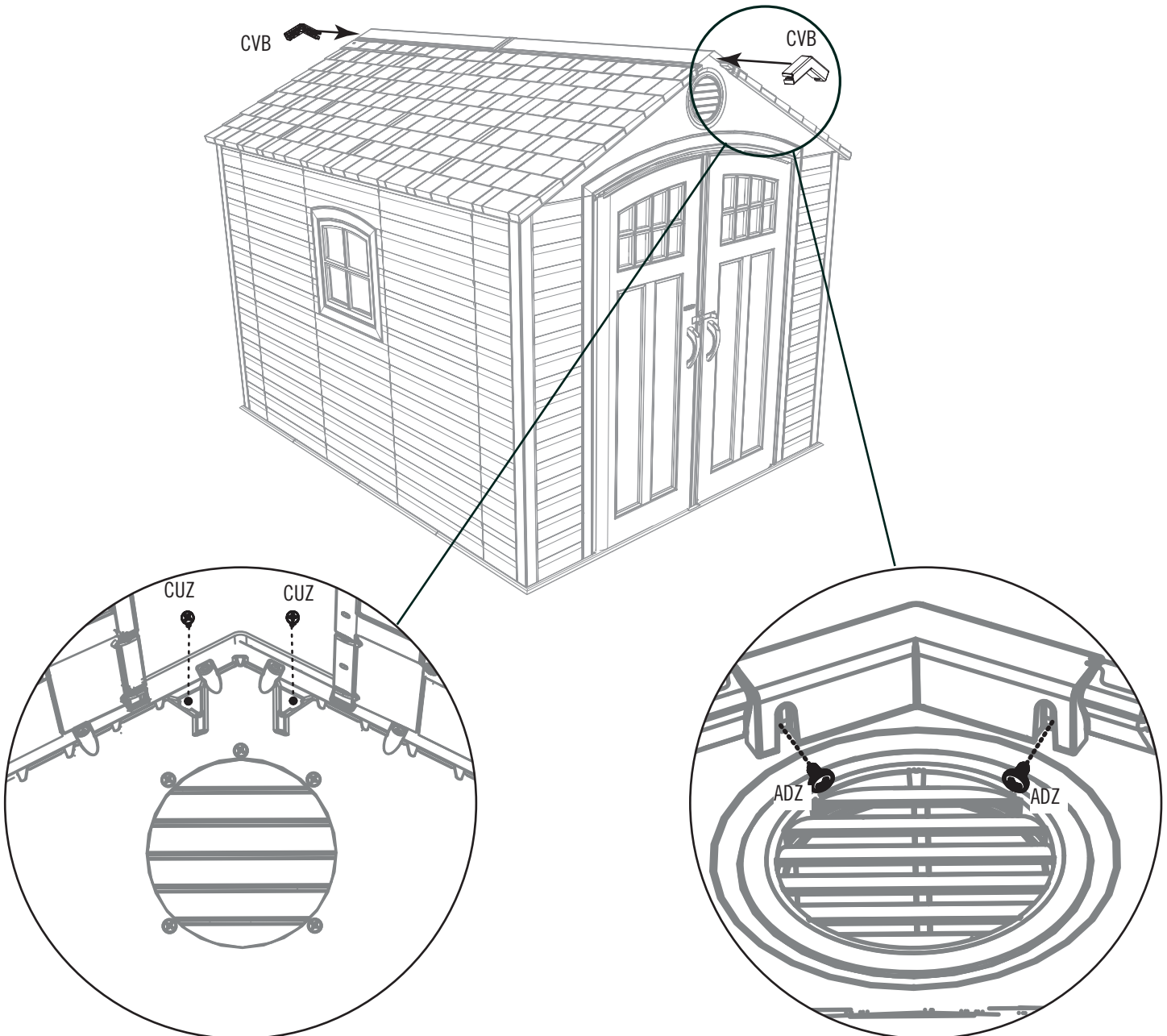



## ► SECTION 10 (CONTINUED) / SECTION 10 (SUITE) / SECCIÓN 10 (CONTINUACIÓN)

TOOLS AND HARDWARE REQUIRED / OUTILS ET QUINCAILLERIE REQUIS / INSTRUMENTAL Y HERRAJE REQUERIDOS

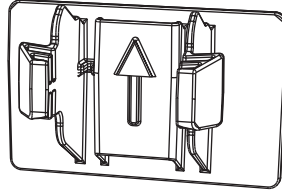

AXX (x2)

### 10.19

- Insert the **Clips (AXX)** with the “arrow” facing up.
- Insérer les **clips (AXX)** avec la « flèche » vers le haut.
- Insertar los **clips (AXX)** con la « flecha » hacia arriba.

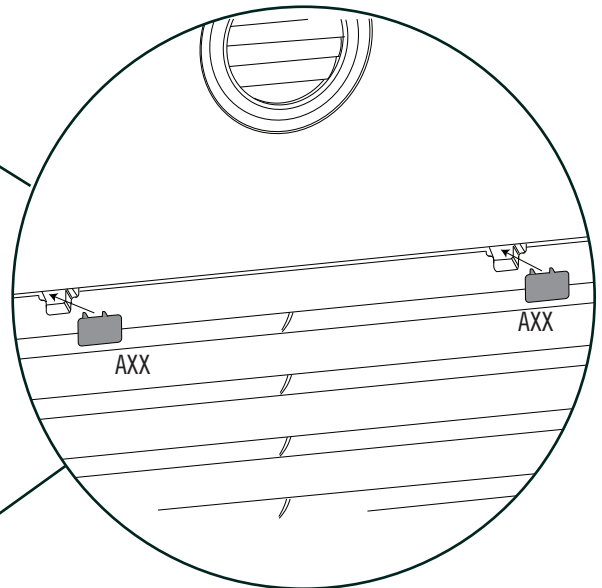
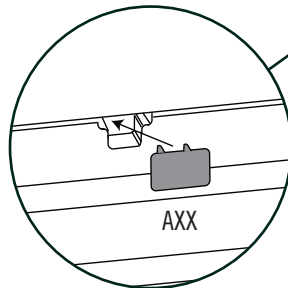
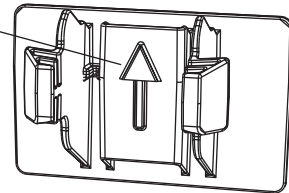
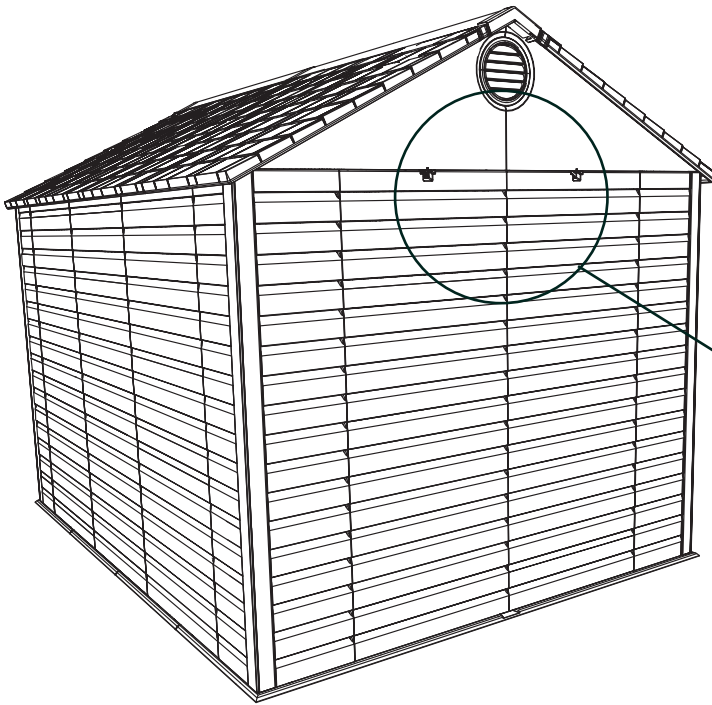





### HARDWARE REQUIRED / QUINCAILLERIE REQUISE / HERRAJE REQUERIDO

Hardware Bag / Sac de quincaillerie / Bolsa de herraje

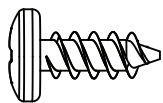

ADZ (x4)

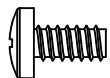

ADY (x1)

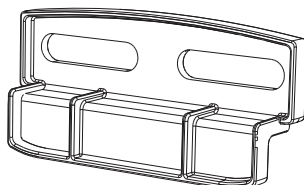

AIS (x2)

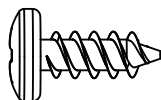

ADZ (x28)



### PARTS REQUIRED / PIÈCES REQUISES / PIEZAS REQUERIDAS

Plastic Parts / Pièces en plastique / Piezas de plástico

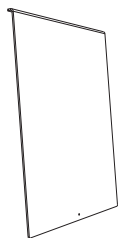

AHE (x1)

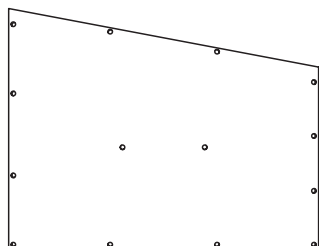

DHN (x2)



### TOOLS REQUIRED / OUTILS REQUIS / INSTRUMENTAL REQUERIDO



## ► SECTION 11 (CONTINUED) / SECTION 11 (SUITE) / SECCIÓN 11 (CONTINUACIÓN)

TOOLS AND HARDWARE REQUIRED / OUTILS ET QUINCAILLERIE REQUIS / INSTRUMENTAL Y HERRAJE REQUERIDOS

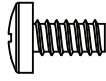

ADY (x1)

### 11.1

- If you have trouble with this section, follow the code below to view a video on how to install the Window Panes.
- En cas d'avoir des problèmes avec cette section, suivre le code en bas pour voir un vidéo sur l'installation dans cette section.
- En caso de tener problemas con esta sección, seguir el código debajo para ver un video sobre la instalación en esta sección.

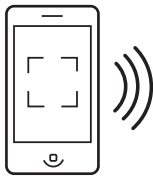

<http://go.lifetime.com/8wininstall>

### 11.2

- Peel off the protective plastic from both sides of the **Window Pane (AHE)**. With the curved edge at the top and facing toward you, slide the Window Pane down into the opening.
- Enlever la pellicule protectrice des deux côtés du **carreau (AHE)**. Avec le bord courbé vers le haut et faisant face à l'intérieur, faire glisser le carreau en place.
- Retirar la película protectora de las dos caras de la **hoja (AHE)**. Con el borde curvado hacia arriba y el interior, deslizar la hoja en su lugar.

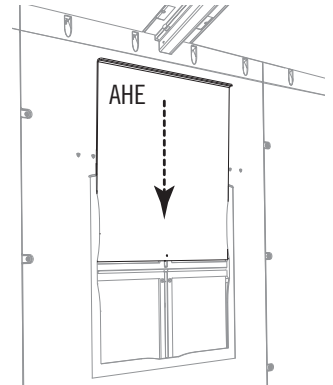
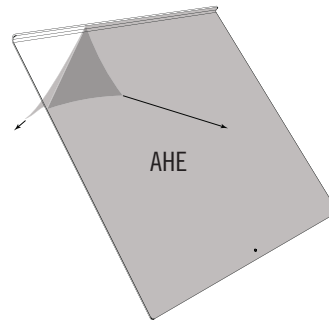

### 11.3

- Insert a **Screw (ADY)** into the hole at the bottom of the Window Pane. **This helps keep the Window Pane up when open.**
- Insérer une **vis (ADY)** dans le trou au bord inférieur du carreau. **Cela aide à maintenir en haut le carreau lorsqu'il est ouvert.**
- Introduzca un **tornillo (ADY)** en el agujero al borde inferior de la hoja. **Esto ayuda a prevenir la cierre de la hoja.**

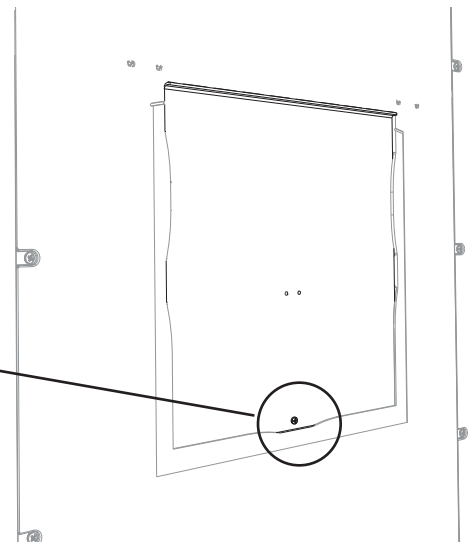
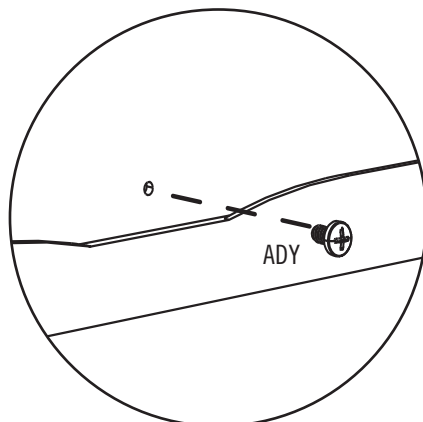

## ► SECTION 11 (CONTINUED) / SECTION 11 (SUITE) / SECCIÓN 11 (CONTINUACIÓN)

TOOLS AND HARDWARE REQUIRED / OUTILS ET QUINCAILLERIE REQUIS / INSTRUMENTAL Y HERRAJE REQUERIDOS

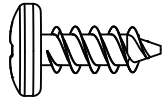

ADZ (x4)

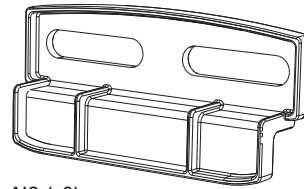

AIS (x2)

### 11.4

- Attach the two (2) **Window Latches (ADY)** at the top corners of the Panel opening. **The Latch should move freely.**
- Attacher les deux (2) **loquets (ADY)** aux angles supérieurs de l'ouverture du panneau. **Le loquet doit se déplacer librement.**
- Sujetar los dos (2) **cerrojos (ADY)** a las esquinas superiores de la abertura del Panel. **El cerrojo debe mover libremente.**

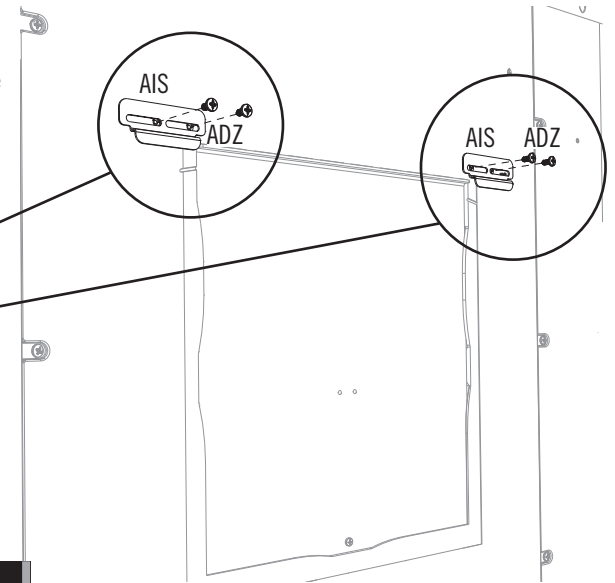
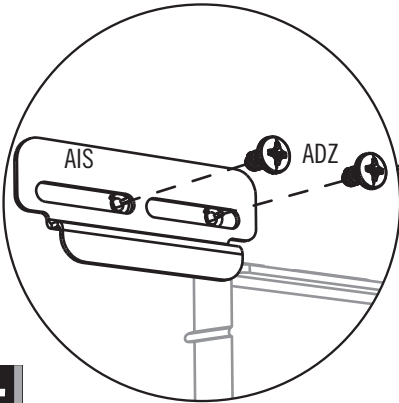

### 11.5

- If you have trouble with this section, follow the code below to view a video on how to install the Window Panes.
- En cas d'avoir des problèmes avec cette section, suivre le code en bas pour voir un vidéo sur l'installation dans cette section.
- En caso de tener problemas con esta sección, seguir el código debajo para ver un video sobre la instalación en esta sección.

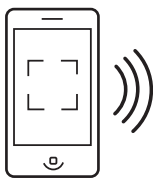

<http://go.lifetime.com/8-panewindowinstall>

### 11.6

- Peel off the protective plastic from both sides of the **Window Pane (DHN)**.
- Enlever la pellicule protectrice des deux côtés du **carreau (DHN)**.
- Retirar la película protectora de las dos caras de la **hoja (DHN)**.

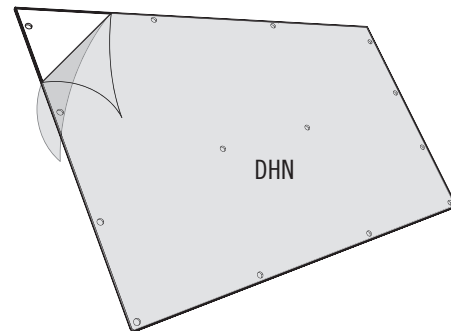

## ► SECTION 11 (CONTINUED) / SECTION 11 (SUITE) / SECCIÓN 11 (CONTINUACIÓN)

TOOLS AND HARDWARE REQUIRED / OUTILS ET QUINCAILLERIE REQUIS / INSTRUMENTAL Y HERRAJE REQUERIDOS

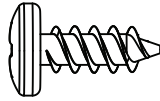

ADZ (x28)

### 11.7

- Align the holes in the Window Pane with those in the Door. Secure the Pane to the Door using fourteen (14) **Screws (ADZ)**.
- Aligner les trous dans le carreau avec ceux dans la porte. Attacher le carreau à la porte à l'aide de quatorze (14) **vis (ADZ)**.
- Alinear los agujeros en la hoja con ellos en la puerta. Sujete la hoja a la puerta usando catorce (14) **tornillos (ADZ)**.

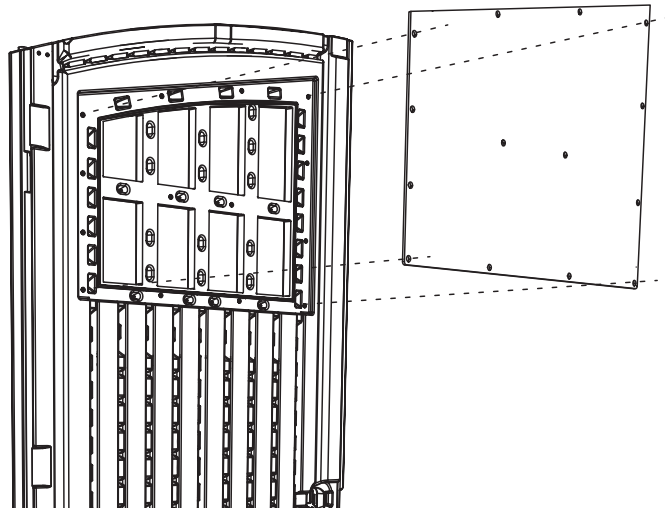

### 11.8

- *Repeat these steps for the second Door.*
- *Répéter ces étapes pour la deuxième porte.*
- *Repetir estos pasos para la segunda puerta.*

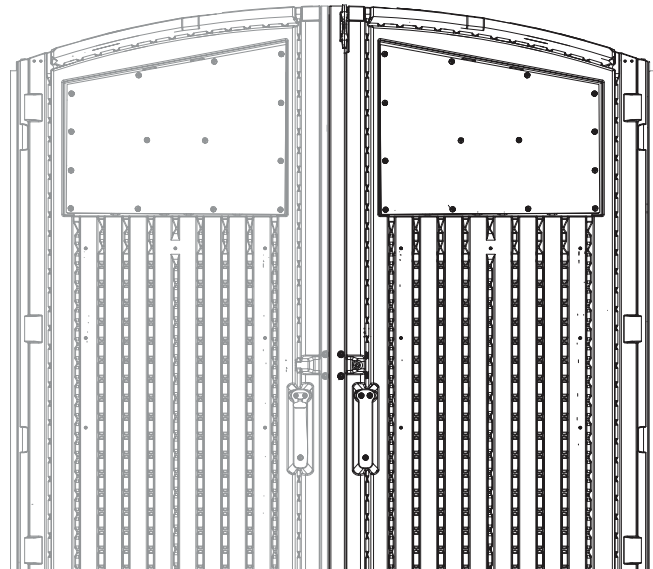



## HARDWARE REQUIRED / QUINCAILLERIE REQUISE / HERRAJE REQUERIDO

*NO HARDWARE INCLUDED FOR THIS SECTION  
AUCUNE QUINCAILLERIE INCLUSE POUR CETTE SECTION  
NINGÚN HERRAJE INCLUIDO PARA ESTA SECCIÓN*



## PARTS REQUIRED / PIÈCES REQUISES / PIEZAS REQUERIDAS

*Plastic Parts / Pièces en plastique / Piezas de plástico*

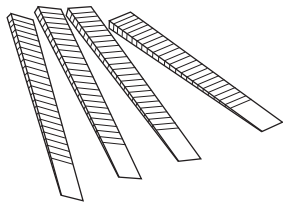

AIX (x4)



## TOOLS REQUIRED / OUTILS REQUIS / INSTRUMENTAL REQUERIDO

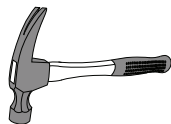

## ► SECTION 12 (CONTINUED) / SECTION 12 (SUITE) / SECCIÓN 12 (CONTINUACIÓN)

TOOLS AND HARDWARE REQUIRED / OUTILS ET QUINCAILLERIE REQUIS / INSTRUMENTAL Y HERRAJE REQUERIDOS



AIX (x4)



### 12.1

- If the Doors are not level, follow the steps on this page or the next to even them out.
- Si les portes ne sont pas niveau l'une avec l'autre, suivre les étapes dans cette page ou la suivante pour les niveler.
- Si las puertas no están niveladas, seguir los pasos en esta página o la siguiente para nivelarlas.



### 12.2

- If the Right Door scrapes the Floor or is lower than the Left Door, insert a **Shim (AIX)** under the Floor directly under the bottom corner of the Right Door and/or the left rear corner of the shed. If necessary, repeat for the Left Door until both Doors are level and do not scrape. **Break off any excess Shim.**
- Si la porte droite frotte en se ferme ou est plus bas que la porte gauche, insérer une **cale (AIX)** sous le plancher directement sous le coin droit inférieur de la porte droite et/ou l'encoignure arrière gauche de l'abri. S'il est nécessaire, répéter cette étape pour la porte gauche jusqu'à ce que les deux portes soient nivelées et ne frottent pas. **Détacher de l'excès des cales.**
- Si la puerta derecha se roza con el piso o es más bajo que la izquierda, insertar una **cuña (AIX)** debajo el piso directamente debajo la esquina inferior derecha de la puerta derecha y/o la esquina izquierda trasera de la caseta. Si es necesario, repetir este paso para la puerta izquierda o hasta que las dos puertas estén niveladas y no se rocen. **Quebrantar cualquier exceso de las cuñas.**

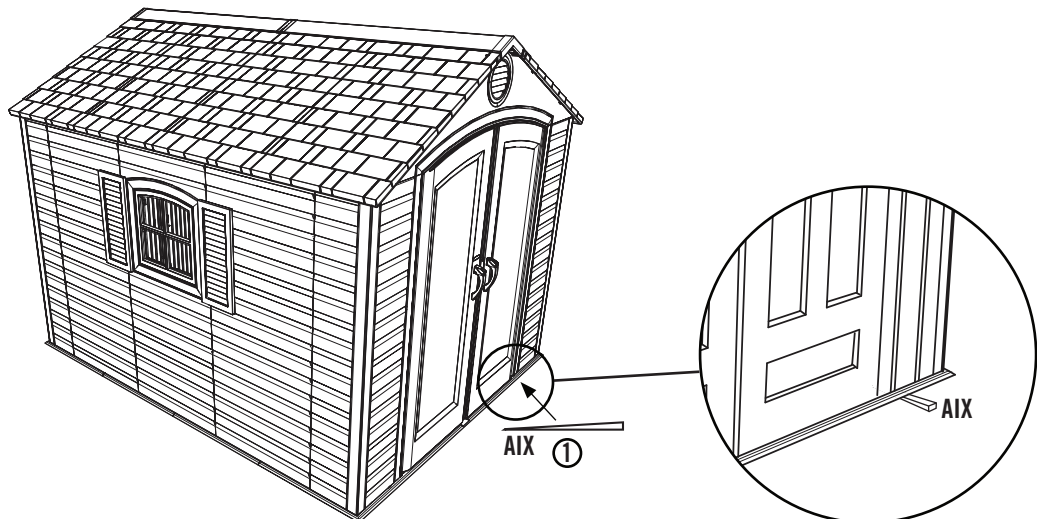

# 13

## SHED ANCHORING / ANCRAGE DE L'ABRI / ANCLAJE DE LA CASETA



### HARDWARE REQUIRED / QUINCAILLERIE REQUISE / HERRAJE REQUERIDO





### PARTS REQUIRED / PIÈCES REQUISES / PIEZAS REQUERIDAS

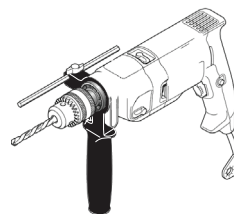
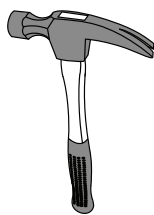

### TOOLS REQUIRED / OUTILS REQUIS / INSTRUMENTAL REQUERIDO



  
5/16" (8 mm) Wood Drill Bit  
5/16" (8 mm) Broca para madera  
5/16" (8 mm) Foret à bois

  
5/16" (8 mm) Masonry Drill Bit  
5/16" (8 mm) Broca para albañilería  
5/16" (8 mm) Foret à maçonnerie



## ▶ SECTION 13 (CONTINUED) / SECTION 13 (SUITE) / SECCIÓN 13 (CONTINUACIÓN)

TOOLS AND PARTS REQUIRED / OUTILS ET PIÈCES REQUIS / INSTRUMENTAL Y HERRAJE REQUERIDOS

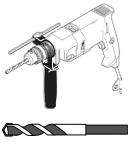

5/16 in/po  
(8 mm)



# 13.1



• To anchor your shed, you must purchase the correct anchoring hardware. **For a concrete platform**, we recommend using a hammer drill, 5/16" (8 mm) masonry bit, eight (8) 3/8" x 2" (10 mm x 5 cm) Concrete Screws and eight (8) 3/8" x 1" (10 mm x 2,5 cm) Fender Washers. **Do not exceed a 3/8" diameter screw. Refer to your local hardware store for this hardware.**

• Pour ancrer l'abri, il faut acheter la quincaillerie d'ancrage correcte. **Pour une plate-forme en béton**, nous recommandons que vous utilisiez une perceuse de percussion, un foret à maçonnerie de 8 mm, huit (8) vis d'ancrage à béton de 10 mm x 5 cm (3/8 po x 2 po) et huit (8) rondelles de protection de 10 mm x 2,5 cm (3/8 po x 1 po). **Ne dépassez pas un diamètre de 10mm (3/8 po). Votre quincaillerie du coin aura ces accessoires.**

• Para anclar la caseta, es necesario comprar el herraje de anclaje correcto. **Para una plataforma de concreto**, recomendamos que use un martillo perforador, broca de albañilería de 8 mm, ocho (8) tornillos de anclaje para concreto de 10 mm x 5 cm (3/8 in x 2 in) y ocho (8) rondanas de protección de 10 mm x 2,5 cm (3/8 in x 1 in). **No exceda un diámetro de 10 mm (3/8 in). Refiérase a su ferretería local para obtener este herraje.**

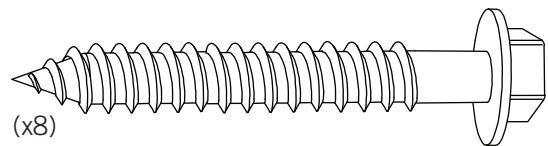
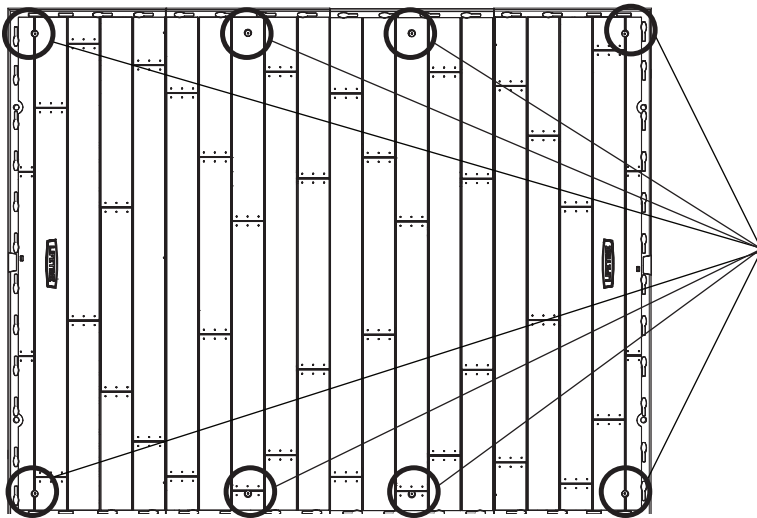

(x8)

(Not included) (Pas incluses) (No incluidos)

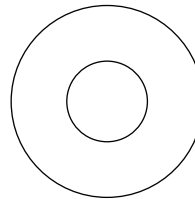

(x8)

(Not included) (Pas incluses) (No incluidas)



### WARNING / AVERTISSEMENT / ADVERTENCIA



- Failure to anchor the shed may result in property damage and/or personal injury.
- Si vous n'ancrez pas votre abri, des dommages à la propriété et/ou des blessures peuvent en résulter.
- No anclar la caseta puede resultar en daños a la propiedad y/o en lesiones personales.

## ► SECTION 13 (CONTINUED) / SECTION 13 (SUITE) / SECCIÓN 13 (CONTINUACIÓN)

TOOLS AND PARTS REQUIRED / OUTILS ET PIÈCES REQUIS / INSTRUMENTAL Y HERRAJE REQUERIDOS



5/16 in/po  
(8 mm)



### 13.1



• To anchor your shed, you must purchase the correct anchoring hardware. **For a wood-framed platform**, we recommend using a drill, 5/16" (8 mm) drill bit, eight (8) 3/8" x 1 1/2" (10 mm x 4 cm) Lag Screws and eight (8) 3/8" x 1" (10 mm x 2,5 cm) Fender Washers. **Do not exceed a 3/8" diameter screw. Refer to your local hardware store for this hardware.**

• Pour ancrer l'abri, il faut acheter la quincaillerie d'ancrage correcte. **Pour une plate-forme en bois**, nous recommandons que vous utilisiez une perceuse électrique, un foret de 8 mm, huit (8) vis de retard de 10 mm x 4 cm (3/8 po x 1 1/2 po), et huit (8) rondelles de protection de 10 mm x 2,5 cm (3/8 po x 1 po). **Ne dépassez pas un diamètre de 10 mm (3/8"). Votre quincaillerie du coin aura ces accessoires.**

• Para anclar la caseta, es necesario comprar el herraje de anclaje correcto. **Para una plataforma hecho de madera**, recomendamos que use un taladro eléctrico, una broca de 8 mm, ocho (8) Tornillos para madera de 10 mm x 4 cm (3/8 in x 1 1/2 in) y ocho (8) Rondanas de protección de 10 mm x 2,5 cm (3/8 in x 1 in). **No exceda un diámetro de 10 mm (3/8 in). Refiérase a su ferretería local para obtener este herraje.**

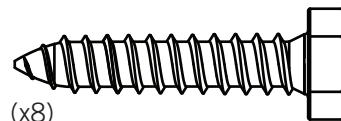
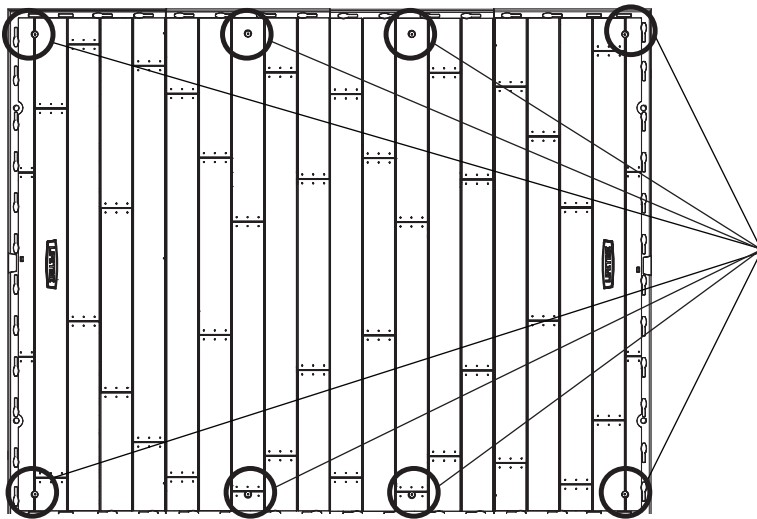

(x8)

(Not included) (Pas incluses) (No incluidos)

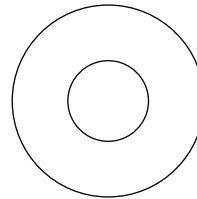

(x8)

(Not included) (Pas incluses) (No incluidas)

### ⚠ WARNING / AVERTISSEMENT / ADVERTENCIA ⚠

- Failure to anchor the shed may result in property damage and/or personal injury.
- Si vous n'ancrez pas votre abri, des dommages à la propriété et/ou des blessures peuvent en résulter.
- No anclar la caseta puede resultar en daños a la propiedad y/o en lesiones personales.

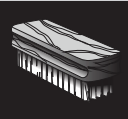

## CLEANING & CARE

**Congratulations on your Lifetime® product purchase. By following the instructions below, your new Lifetime product should provide you with years of service and enjoyment.**

The polyethylene panels are stain and solvent resistant. Most stains can be removed using a mild soap and a soft-bristled brush. Abrasive cleaning materials may scratch the plastic and are not recommended. Repair scratches or rust spots on the metal by sanding the affected area lightly; using a rust preventative spray primer; and finally, spraying with a high-gloss spray enamel paint. Avoid placing a direct heat source on or near surfaces unless using a heat barrier.



## NETTOYAGE ET ENTRETIEN

**Nous vous félicitons d'avoir acheté ce produit Lifetime®. En suivant les instructions ci-dessous, votre nouveau produit Lifetime devrait vous fournir des années de service et de plaisir.**

Les murs et les étagères en polyéthylène sont résistants aux taches et solvants de nettoyage. Pour les nettoyer, se servir d'un savon doux et d'une brosse douce. Les produits abrasifs de nettoyage risquent d'égratigner le plastique et ne sont pas recommandés. Pour réparer les égratignures ou taches de rouille sur le métal, frotter légèrement l'endroit affecté au papier de verre, puis passer une couche de produit vaporisant préventif, et, enfin, vaporiser une peinture émail ultrabrillante. Éviter de placer une source de chaleur directe sur ou près des surfaces, ou les protéger à l'aide d'une protection contre la chaleur.



## LIMPIEZA Y CUIDADO

**Felicidades por la compra de su producto Lifetime®. Al seguir las siguientes instrucciones, su nuevo producto Lifetime le brindará años de servicio y satisfacción.**

Los paneles de polietileno son resistentes a las manchas y solventes. La mayoría de las manchas puede removerse usando un jabón suave y un cepillo de cerdas suaves. Los materiales abrasivos para limpieza pueden rayar el plástico y no se recomiendan. Reparar rayones o manchas de óxido en el metal, lijando suavemente la parte afectada; usando un aerosol preventivo de óxido y finalmente, rociando con una pintura de esmalte brillante. Evitar poner una fuente de calor directa en o cerca de las superficies sin usar una barrera de calor.



## REGISTER YOUR PRODUCT ONLINE AT WWW.LIFETIME.COM

At Lifetime®, we are committed to providing innovative and quality products. While registering, you will have the opportunity to give us your feedback. Your input is valuable to us.

- You can also opt in to receive new product notifications or promotions.
- In the unlikely event of a product recall or safety modification, your registration provides the information we need to notify you directly.
- Registration is fast, easy, and completely voluntary.

### LIFETIME'S PROMISE TO YOU:

*Maintaining your privacy is our long-standing policy at Lifetime®. And you can rest assured that Lifetime® will not sell or provide your personal data to other third parties, or allow them to use your personal data for their own purposes.*

We invite you to read our privacy policy at [www.lifetime.com](http://www.lifetime.com)

**REGISTER today!**



## ENREGISTRER CE PRODUIT EN LIGNE À WWW.LIFETIME.COM

Chez Lifetime®, nous nous engageons à fournir des produits innovateurs de qualité. Lors de votre inscription, vous aurez l'occasion de nous faire parvenir vos commentaires. Votre opinion est importante pour nous.

- On peut également choisir de recevoir des avis ou des promotions dans le cadre de nouveaux produits.
- Dans l'éventualité improbable d'un rappel ou d'un avis de sécurité, l'inscription fournit les renseignements nécessaires nous permettant de communiquer avec vous.
- L'inscription est rapide, facile et complètement volontaire.

### LA PROMESSE DE LIFETIME :

*Conserver votre confidentialité est notre politique de longue date chez Lifetime®. Vous pouvez donc être rassuré par le fait que Lifetime® ne vendra pas ou ne fournira pas vos données personnelles à des tiers, et ne leur permettra pas d'utiliser vos données personnelles à leurs propres fins.*

Nous vous invitons à lire notre politique de confidentialité à [www.lifetime.com](http://www.lifetime.com) (en anglais seulement)

**ENREGISTRER CE PRODUIT aujourd'hui!**



## REGISTRAR EL PRODUCTO EN LÍNEA EN WWW.LIFETIME.COM

En Lifetime®, estamos comprometidos a ofrecer productos innovadores y de calidad. Al registrarse, usted tendrá la oportunidad de darnos su retroalimentación. Su información es valiosa para nosotros.

- También puede optar por recibir nuestras notificaciones o promociones.
- En el caso improbable de que el producto deba ser retirado del mercado o que sufra alguna modificación, su registro provee la información que necesitamos para notificarle directamente.
- El registro es rápido, fácil y completamente voluntario.

### LA PROMESA DE LIFETIME® PARA USTED:

*Mantener privacidad es nuestra política permanente en Lifetime®. Y puede estar seguro que Lifetime® no venderá ni dará datos personales a terceros, ni les permitirá usar datos personales para sus propios fines.*

Lo invitamos a leer nuestra política de privacidad en [www.lifetime.com](http://www.lifetime.com) (sólo en inglés)

**¡REGISTRARSE hoy mismo!**



**NOTES / REMARQUES / NOTAS**





A large, empty white rectangular area intended for writing notes or remarks.





## 10-YEAR LIMITED FACTORY WARRANTY

**THE MANUFACTURER RESERVES THE RIGHT TO MAKE SUBSTITUTIONS TO WARRANTY CLAIMS IF PARTS ARE UNAVAILABLE OR OBSOLETE.**

1. Lifetime outdoor sheds are warranted to the original purchaser to be free from defects in material or workmanship for a period of ten years from the date of original retail purchase. The word “defects” is defined as imperfections that impair the use of the product. Defects resulting from misuse, abuse or negligence will void this warranty. This warranty does not cover defects due to improper installation, alteration or accident. This warranty does not cover damage caused by vandalism, rusting, “acts of nature” or any other event beyond the control of the manufacturer.
2. This warranty is nontransferable and is expressly limited to the repair or replacement of defective product. If the product is defective within the terms of this warranty, Lifetime Products, Inc. will repair or replace defective parts at no cost to the purchaser. Shipping charges to and from the factory or distribution center are not covered and are the responsibility of the purchaser. Labor charges and related expenses for removal, installation or replacement of the shed or its components are not covered under this warranty.
3. This warranty does not cover scratching or scuffing of the product that may result from normal usage. In addition, defects resulting from intentional damage, negligence, unreasonable use or hanging from the truss will void this warranty.
4. Liability for incidental or consequential damages is excluded to the extent permitted by law. While every attempt is made to embody the highest degree of safety in all equipment, freedom from injury cannot be guaranteed. The user assumes all risk of injury resulting from the use of this product. All merchandise is sold on this condition, and no representative of the company may waive or change this policy.
5. This product is not intended for institutional or commercial use; Lifetime Products, Inc. does not assume any liability for such use. Institutional or commercial use will void the warranty.
6. Our goods come with guarantees that cannot be excluded under the Australian Consumer Law. You are entitled to a replacement or refund for a major failure and for compensation for any other reasonably foreseeable loss or damage. You are also entitled to have the goods repaired or replaced if the goods fail to be of acceptable quality and the failure does not amount to a major failure.
7. This warranty is expressly in lieu of all other warranties, expressed or implied, including warranties of merchantability or fitness for use to extent permitted by Federal and state law. Neither Lifetime Products, Inc., nor any representative assumes any other liability in connection with this product. This warranty gives you specific legal rights, and you may also have other rights which vary from state to state (or province to province, as applicable in Canada).

**PLEASE INCLUDE YOUR DATED SALES RECEIPT AND PHOTOGRAPHS OF DAMAGED PARTS.**

REPORT PRODUCT DEFECTS IN WRITING TO:

Lifetime Products, Inc., PO Box 160010 Clearfield, UT 84016-0010  
or call 1-800-225-3865 M-F 7 a.m. to 5 p.m. MST.

**REGISTER YOUR PRODUCT FOR QUICKER CUSTOMER SERVICE.**

Visit [www.lifetime.com](http://www.lifetime.com) or call 1-800-225-3865 to register your product today.

**FOR INTERNATIONAL WARRANTY CLAIMS:**

All warranty claims must be accompanied by a sales receipt. Report all warranty claims in writing to your regional sales support representative. Please include your dated sales receipt and photographs of damaged parts. To identify the representative for your region, please visit: [www.lifetime.com/international](http://www.lifetime.com/international)



[www.lifetime.com](http://www.lifetime.com)



## GARANTIE DE FABRICATION LIMITÉE DE 10 ANS

### LE FABRICANT SE RÉSERVE LE DROIT DE FAIRE DES SUBSTITUTIONS EN CAS DE RECOURS EN GARANTIE SI LES PIÈCES NE SONT PAS DISPONIBLES OU SONT OBSOLÈTES.

1. Les abris extérieurs Lifetime® sont garantis à l'acheteur d'origine contre tous défauts de matériau ou de fabrication pendant une durée de dix (10) ans à partir de la date d'achat d'origine. Le mot « défauts » signifie des défauts qui empêchent l'utilisation du produit. Les défauts résultant de mauvais usage, d'abus ou de négligence annulent cette garantie. Cette garantie ne couvre pas les dommages causés par le vandalisme, la rouille, « les catastrophes naturelles » ou tout autre événement en dehors du contrôle du fabricant.
2. Cette garantie n'est pas transférable et est expressément limitée à la réparation ou au remplacement du produit défectueux. Si le produit est déclaré défectueux selon les termes de cette garantie, Lifetime® Products, Inc. réparera ou remplacera les parties défectueuses gratuitement pour l'acheteur. Les frais d'expédition aller et retour de l'usine ne sont pas couverts et sont à la charge de l'acheteur. Les frais de main-d'œuvre et frais associés à l'enlèvement, au montage ou au remplacement de l'abri ou de ses composants ne sont pas couverts par cette garantie.
3. Cette garantie ne couvre pas les égratignures ou éraflures du produit résultant d'une utilisation normale. Par ailleurs, les défauts résultant de dommages intentionnels, négligence, utilisation abusive ou suspension à partir de l'entretoise annulent cette garantie.
4. Toute responsabilité pour dommages incidents ou consécutifs est exclue dans la mesure permise par la loi. Bien que toutes les mesures aient été prises pour intégrer le plus haut degré de sécurité dans l'ensemble du matériel, l'impossibilité de blessure ne peut pas être garantie. L'utilisateur assume tous les risques de blessure résultant de l'utilisation de ce produit. L'ensemble de la marchandise est vendu en vertu de cette condition et aucune personne représentant la société ne peut déroger à cette politique, ni la modifier.
5. Ce produit n'est pas prévu pour l'usage institutionnel ou commercial; Lifetime® Products, Inc. n'assume aucune responsabilité pour un tel usage. L'utilisation institutionnelle ou commerciale annulera cette garantie.
6. Nos articles sont offerts avec des garanties qui ne peuvent connaître d'exclusions en vertu de la loi australienne sur la protection des consommateurs. Vous avez droit au remplacement ou au remboursement en cas de défaillance majeure de votre article ainsi qu'à une compensation en cas de perte ou de dommage prévisible. Vous avez aussi droit à la réparation ou au remplacement de l'article s'il n'est pas d'une qualité acceptable et que la défaillance n'est pas majeure.
7. Cette garantie remplace expressément toutes les autres garanties, expresses ou tacites, y compris les garanties de commercialisation ou d'adaptation à un but particulier dans la mesure permise par les lois fédérales et des états. Ni Lifetime® Products, Inc. ni aucun de ses représentants n'assume d'autre responsabilité concernant ce produit. Cette garantie vous accorde des droits particuliers, et vous aurez peut-être d'autres droits qui varient d'un état à l'autre (ou d'une province à l'autre, selon le cas au Canada).

### TOUS LES RECOURS EN GARANTIE DOIVENT ÊTRE ACCOMPAGNÉS DU REÇU DE VENTE.

FAIRE PARVENIR PAR ÉCRIT UN RAPPORT PAR ÉCRIT DE DÉFECTUOSITÉ DU PRODUIT À :

Lifetime Products, Inc., PO Box 160010 Clearfield, UT 84016-0010

ou composer 1-800-225-3865 lundi à vendredi 7 h – 17 h (HNR)

### ENREGISTRER VOTRE ARTICLE À :

[www.lifetime.com](http://www.lifetime.com), ou composer 1-800-225-3865 pour enregistrer votre article aujourd'hui.

### POUR RECOURS EN GARANTIE INTERNATIONAUX :

Tous les recours en garantie doivent être accompagnés du reçu de vente. Faire parvenir par écrit un rapport par écrit de défaut du produit au représentant régional de ventes. Veiller inclure votre reçu de vente daté et les photographies des pièces endommagées. Pour identifier le représentant régional, visiter [www.lifetime.com/international](http://www.lifetime.com/international)



[www.lifetime.com](http://www.lifetime.com)



## GARANTÍA DE FÁBRICA LIMITADA POR 10 AÑOS

### EL FABRICANTE SE RESERVA EL DERECHO DE HACER SUSTITUCIONES EN LOS ELEMENTOS REEMPLAZADOS BAJO GARANTÍA SI LAS PIEZAS NO ESTÁN DISPONIBLES O SON OBSOLETAS.

1. El comprador original recibe la garantía de que las casetas Lifetime estarán libres de defectos de material o de mano de obra por un período de 10 años a contar desde la fecha de la compra original. La palabra “defectos” se define como imperfecciones que perjudican el uso del producto. Los defectos emergentes de un mal uso, abuso o negligencia invalidarán esta garantía. Esta garantía no cubre defectos debidos a una instalación o alteración incorrecta o a un accidente. Esta garantía no cubre daños causados por vandalismo, oxidación, “actos de la naturaleza” u otros eventos que estén más allá del control del fabricante.
2. Esta garantía es intransferible, y queda expresamente limitada a la reparación o reemplazo de los productos defectuosos. Si el producto se encuentra defectuoso dentro de los términos de esta garantía, Lifetime Products, Inc. reparará o reemplazará las piezas defectuosas sin costo alguno para el comprador. Los gastos de envío hacia y desde la fábrica no están cubiertos, y quedan bajo la responsabilidad del comprador.
3. Esta garantía no cubre raspaduras ni marcas en el producto que pueden resultar de su uso normal. Además, los defectos causados por daños intencionales, negligencia, uso irrazonable o por colgarse de las cabriadas invalidarán esta garantía.
4. La responsabilidad por daños incidentales o consecuentes queda excluida hasta el punto en que lo permita la ley. Si bien se hace el mayor esfuerzo posible para lograr el más alto grado de seguridad en todos nuestros equipos, no puede garantizarse la libertad de cualquier tipo de lesión. El usuario asume todos los riesgos de lesiones emergentes del uso de este producto. Toda nuestra mercadería se vende bajo esta condición, y ningún representante de la compañía puede anular ni cambiar esta política.
5. Este producto no está pensado para el uso institucional ni comercial; Lifetime Products, Inc. no asume ninguna otra responsabilidad en conexión con este producto. El uso institucional o comercial invalidará la garantía.
6. Nuestros productos vienen con garantías que no se pueden excluir bajo la Ley del consumidor de Australia. Ustedes están autorizados para reemplazarlos u otorgar una devolución o reembolso en caso de falla mayor y en compensación por cualquier otra falla o daño previsible. También, están autorizados para hacer reparar los productos o reemplazarlos si éstos no cumplen con una calidad aceptable y si la falla no es motivo de una deficiencia mayor.
7. Esta garantía se otorga en reemplazo expreso de toda otra garantía, expresa o implícita, incluidas las garantías de comercialización o adaptación para el uso en la medida permitida por las leyes federales y estatales. Ni Lifetime Products, Inc., ni ninguno de sus representantes asume ninguna otra responsabilidad en conexión con este producto. Esta garantía le otorga derechos legales específicos, y usted puede tener otros derechos que varían de estado a estado (o de una provincia a otra, según corresponda en Canadá).

### NINGUNA GARANTÍA OFRECIDA POR EL FABRICANTE ES VÁLIDA EN MÉXICO

### TODOS LOS RECLAMOS DE GARANTÍA DEBEN ESTAR ACOMPAÑADOS POR UN RECIBO DE COMPRA

INFORME POR ESCRITO LOS DEFECTOS EN EL PRODUCTO A:

Por favor, incluir el recibo de compra fechado y fotografías de las piezas dañadas.

Lifetime Products, Inc., PO Box 160010 Clearfield, UT 84016-0010,

o marcar al 1.800.225.3865 de lunes a viernes de 7:00 h hasta 17:00 h (Hora de las Montañas)

### REGISTRAR SU PRODUCTO

Visitar nuestra página en Internet [www.lifetime.com](http://www.lifetime.com), o marcar al 1.800.225.3865 para registrar el producto hoy.

### PARA RECLAMOS DE GARANTÍA INTERNACIONALES:

Todos los reclamos de garantía deben estar acompañados por un recibo de compra. Informar por escrito todos los reclamos de garantía a su representante regional de ventas. Favor de incluir el recibo de compra fechado y fotografías de las piezas dañadas.

Para identificar el representante regional, visitar [www.lifetime.com/international](http://www.lifetime.com/international)



[www.lifetime.com](http://www.lifetime.com)

**ENHANCE YOUR LIFETIME® PURCHASE BY ADDING ACCESSORIES OR OTHER GREAT PRODUCTS**

*To purchase accessories or other Lifetime® products, visit us at:*

***www.lifetime.com***

*Or call: 1-800-424-3865*

*7:00 am–5:00 pm (M–F) MST and 9:00 am–1:00 pm Saturday MST*

**AMÉLIORER VOTRE ACHAT LIFETIME® EN AJOUTANT DES ACCESSOIRES OU DES AUTRES PRODUITS**

*Pour acheter des accessoires ou d'autres produits Lifetime®, nous rendre visite à :*

***www.lifetime.com***

*Ou composer le 1-800-424-3865*

*Du lundi au vendredi 7 h – 17 h (HNR) et samedi 9 h – 13 h (HNR)*

**MEJORAR SU COMPRA LIFETIME® Y AÑADIR ACCESORIOS U OTROS PRODUCTOS EXCELENTES**

*Para comprar accesorios u otros productos Lifetime® EUA, visítenos en:*

***www.lifetime.com***

*O marcar al: 1.800.424.3865*

*De lunes hasta viernes 7:00 h–17:00 h (HNR) y sábado 9:00 h–13:00 h (HNR)*



**www.lifetime.com**

