

**NEVER LEAVE THE HEATER UNATTENDED WHILE BURNING!**

*If you have questions or comments, contact us.*

*Pour toute question ou tout commentaire, nous contacter.*

*Llámenos si tiene alguna pregunta o comentario.*

**855-805-5745 • [www.DEWALT.com](http://www.DEWALT.com)**

**INSTRUCTION MANUAL  
GUIDE DE UTILISATION  
MANUAL DE INSTRUCCIONES**

# DEWALT®

**Cordless Kerosene Forced-Air Heater DXH90CFAK, DXH90CFAKM  
Radiateur au Kérosène à Ventilation Forcée DXH90CFAK, DXH90CFAKM  
Calefactor de Aire Forzado a Kerosene DXH90CFAK, DXH90CFAKM**

**SAVE THESE INSTRUCTIONS  
CONSERVEZ CES INSTRUCTIONS  
GUARDE ESTAS INSTRUCCIONES**

**⚠WARNING: READ INSTRUCTIONS CAREFULLY:** Read and follow all instructions. Place instructions in a safe place for future reference. Do not allow anyone who has not read these instructions to assemble, adjust or operate the heater.

**⚠AVERTISSEMENT: VEUILLEZ LIRE ATTENTIVEMENT LES INSTRUCTIONS :** Lisez et observez toutes les instructions. Conservez ces instructions dans un endroit sécuritaire pour vous y référer ultérieurement. Interdisez à quiconque n'ayant pas lu les présentes directives d'assembler, de régler ou de faire fonctionner cette fournaise.

**⚠ADVERTENCIA: LEA CUIDADOSAMENTE LAS INSTRUCCIONES:** Lea y siga todas las instrucciones. Conserve estas instrucciones en un lugar seguro para futura referencia. No permita que nadie que no haya leído estas instrucciones arme, ajuste o use el calefactor.

# NEVER LEAVE THE HEATER UNATTENDED WHILE BURNING!

## Definitions: Safety Guidelines

The definitions below describe the level of severity for each signal word. Please read the manual and pay attention to these symbols.

- ⚠ **DANGER:** Indicates an imminently hazardous situation which, if not avoided, **will** result in **death or serious injury**.
- ⚠ **WARNING:** Indicates a potentially hazardous situation which, if not avoided, **could** result in **death or serious injury**.
- ⚠ **CAUTION:** Indicates a potentially hazardous situation which, if not avoided, **may** result in **minor or moderate injury**.
- NOTICE:** Indicates a practice not related to personal injury which, if not avoided, **may** result in **property damage**.

⚠ **WARNING:** FIRE BURN, INHALATION, AND EXPLOSION HAZARD. KEEP SOLID COMBUSTIBLES, SUCH AS BUILDING MATERIALS, PAPER, OR CARDBOARD, A SAFE DISTANCE AWAY FROM THE HEATER AS RECOMMENDED BY THE INSTRUCTIONS. NEVER USE THE HEATER IN SPACES WHICH DO OR MAY CONTAIN VOLATILE OR AIRBORNE COMBUSTIBLES, OR PRODUCTS SUCH AS GASOLINE, SOLVENTS, PAINT THINNER, DUST PARTICLES OR UNKNOWN CHEMICALS.

### ⚠ **WARNING: GENERAL HAZARDS**

FAILURE TO COMPLY WITH THE PRECAUTIONS AND INSTRUCTIONS PROVIDED WITH THIS HEATER, CAN RESULT IN DEATH, SERIOUS BODILY INJURY AND PROPERTY LOSS OR DAMAGE FROM HAZARDS OF FIRE, EXPLOSION, BURN, ASPHYXIATION, CARBON MONOXIDE POISONING, AND/OR ELECTRICAL SHOCK.

ONLY PERSONS WHO CAN UNDERSTAND AND FOLLOW THE INSTRUCTIONS SHOULD USE OR SERVICE THIS HEATER.

IF YOU NEED ASSISTANCE OR HEATER INFORMATION SUCH AS AN INSTRUCTIONS MANUAL, LABELS, ETC. CONTACT THE MANUFACTURER. SAVE THESE INSTRUCTIONS FOR FUTURE REFERENCE.

⚠ **WARNING:** This product can expose you to chemicals including lead and lead compounds, which are known to the State of California to cause cancer and birth defects or other reproductive harm. Wash your hands after handling this product. For more information go to [www.P65Warnings.ca.gov](http://www.P65Warnings.ca.gov).

⚠ **WARNING:** DO NOT MOVE, HANDLE, OR RELOCATE WHILE HEATER IS POWERED ON.

⚠ **WARNING: CARBON MONOXIDE CAN KILL YOU**  
USING A PORTABLE HEATER IN AN ENCLOSED AREA CAN PRODUCE DEADLY CARBON MONOXIDE.

⚠ **WARNING:** NOT FOR HOME OR RECREATIONAL VEHICLE USE.

This is an unvented oil-fired portable heater. It uses air (oxygen) from the area in which it is used. Adequate combustion and ventilation air must be provided. Refer to Safety Precautions on page 4.

### ⚠ **WARNING:**

- DO NOT USE GASOLINE, NAPHTHA OR VOLATILE FUELS.
- STOP HEATER AND ALLOW TO COOL BEFORE ADDING FUELS.
- ALWAYS FILL OUTDOORS AWAY FROM OPEN FLAME.
- DO NOT USE EXTERNAL FUEL SOURCE.
- DO NOT OPERATE HEATER WHERE FLAMMABLE LIQUIDS OR VAPORS MAY BE PRESENT.
- DO NOT START HEATER WHEN CHAMBER IS HOT.
- DO NOT START HEATER WHEN EXCESS FUEL HAS ACCUMULATED IN THE CHAMBER.
- DO NOT PLACE COOKING UTENSILS ON TOP OF THE HEATER.
- DO NOT PLACE CLOTHING OR OTHER COMBUSTIBLE ARTICLES ON TOP OF HEATER
- PLUG ELECTRICAL CORD INTO A PROPERLY GROUNDED THREE-PRONG RECEPTACLE.

# NEVER LEAVE THE HEATER UNATTENDED WHILE BURNING!

## Heater Specifications

CSA certified for use with only No. 1-K kerosene fuel. Factory Tested:  
Kerosene, Diesel #1 and #2, Fuel Oil #1 and #2, JP8 (Jet A Fuel)

MODEL NO.: ..... DXH90CFAK, DXH90CFAKM  
 BTU/hr: ..... HIGH (MAX) 90,000 BTU/hr  
 (26.3 kW)  
 BTU/hr: ..... LOW (ECO) 75,000 BTU/hr  
 (22 kW)  
 CONSUMPTION RATE: ..... MAX 0.67 GAL/hr  
 (2.5 L/hr)  
 CONSUMPTION RATE: ..... ECO 0.56 GAL/hr  
 (2.1 L/hr)  
 TANK CAPACITY: ..... 4 GALLONS  
 (15.14 L)  
 FUEL RUN TIME: ..... ECO: 6.3 hours  
 MAX: 5.25 hours  
 ELECTRICAL INPUT: ..... 115 V, 60 HZ, 1.8 A  
 ASSEMBLED DIMENSIONS: ..... 13.25" X 25" X 22.25"  
 (33.6 cm X 63.5 cm X 56.5 cm)  
 DRY WEIGHT: ..... 30 lbs. (13.61 kg)  
 FULL WEIGHT: ..... 56 lbs. (25.4 kg)  
 APPROXIMATE HEATING AREA: ..... 2250 SQ. FT (209 SQ. m)  
 THERMOSTAT RANGE: ..... 23°F to 99°F (-5 °C to 37.2 °C)

**⚠WARNING: CERTIFIED FOR USE WITH DeWALT RECHARGEABLE BATTERY PACKS REFER TO CHART BELOW A LIST OF APPROVED BATTERIES.**

**⚠WARNING: If the information in this manual is not followed exactly, a fire or explosion may result causing injury or loss of life.**

- Do not store or use gasoline or other flammable vapors and liquids in the vicinity of this or any other appliance.
- Service must be performed by a qualified service agency.

## Approved Battery Packs

20V MAX*				12AH FLEXVOLT®			
# of Packs	Battery Capacity	Run Time Hr.**	Run Time Min.**	# of Packs	Battery Capacity	Run Time Hr.**	Run Time Min.**
1	1.3Ah	0.65	39	1	6.0Ah	3	180
1	1.5Ah	0.75	45	1	9.0Ah	4.5	270
1	2.0Ah	1	60	1	12.0Ah	6	360
1	3.0Ah	1.5	90	2	6.0Ah	6	360
1	4.0Ah	2	120	2	9.0Ah	9	540
1	5.0Ah	2.5	150	2	12.0Ah	12	720
1	6.0Ah	3	180	All run times are approximate. Actual run times may vary. State of charge, battery temperature and battery age will all affect actual runtime * Maximum initial battery voltage (measured without a workload) is 20 volts. Nominal voltage is 18. **Calculation assuming 73°F (23°C) ambient temp battery pack			
1	9.0Ah	4.5	270				
2	1.3Ah	1.3	78				
2	1.5Ah	1.5	90				
2	2.0Ah	2	120				
2	3.0Ah	3	180				
2	4.0Ah	4	240				
2	5.0Ah	5	300				
2	6.0Ah	6	360				
2	9.0Ah	9	540				

## Clearance To Combustibles

From Outlet	From Sides	From Top	From Rear
8 ft (2.4m)	3ft (1 m)	3ft (1 m)	3ft (1 m)

# NEVER LEAVE THE HEATER UNATTENDED WHILE BURNING!

## **⚠ WARNING**

Not suitable for use on wood floors or other combustible materials. When used the heater should rest on a suitable insulating material at least 1 inch thick and extending 3 feet or more beyond the heater in all directions.

## **CONTENTS**

WARNINGS	2
HEATER SPECIFICATIONS	3
OPERATING & SAFETY PRECAUTIONS	4
OPERATING INSTRUCTIONS	5
MAINTENANCE	6
ELECTRICAL PRECAUTIONS	7
CHARGING PRECAUTIONS	9
BATTERY PRECAUTIONS	9
CHARGER OPERATION	12
WARRANTY BATTERY /CHARGERS	13
TROUBLESHOOTING	15
EXPLODED VIEW AND PARTS LIST	17
WIRING DIAGRAM	19
WARRANTY	20

## **⚠ WARNING: Operating Precautions**

This is a kerosene, direct-fired, radiant heater. It's intended use is primarily temporary heating of buildings under construction, alteration or repair.

Direct-Fired means that all of the combustion products enter the heated space. Even though this heater operates very close to 100 percent combustion efficiency, it still produces small amounts of carbon monoxide. Carbon monoxide (called CO) is toxic. CO can build up in a heated space and failure to provide adequate ventilation could result in death. The symptoms of inadequate ventilation are:

- Headache
- Dizziness
- Burning eyes and nose
- Nausea
- Dry mouth or sore throat

Be sure to follow advice about ventilation in the Safety Precautions section.

Forced Air means that a blower or fan pushes the air through the heater. Proper combustion depends upon this air flow; therefore, the heater must not be revised, modified or operated with parts removed or missing. Likewise, safety systems must not be circumvented or modified in order to operate the heater.

When the heater is to be operated in the presence of other people the user is responsible for properly acquainting those present with the safety precautions and instructions, and of the hazards involved.

## **⚠ WARNING: Safety Precautions**

**THIS IS A HEATING APPLIANCE. DO NOT ATTEMPT TO WARM OR COOK FOOD ON THIS HEATER.**

1. Recommended for use with No. 1-K kerosene fuel. Factory tested for use with No.2-K kerosene, No.1 or No.2 Diesel, No.1 or No.2 fuel oil or JP8 Jet A fuel and these fuels may be used as well. Never use gasoline, biodiesel, oil drained from crank cases, naphtha, paint thinners, alcohol or any other highly flammable fuels.
2. Check the heater thoroughly for damage. DO NOT operate a damaged heater.
3. DO NOT modify the heater or operate a heater which has been modified from its original condition.
4. Suitable for either outdoor or indoor use where adequate ventilation is provided. Never use in areas normally for habitation. Not for use where exposed to weather.
5. Use in well ventilated areas, provide at least 2 sq. ft. (0.2 sq. m.) of opening near the floor and 2 sq. ft. (0.2 sq. m.) near the ceiling directly to outdoors. Increase air openings as marked for each additional heater.
6. **Caution:** Due to the high surface and exhaust temperatures, adults and children must observe clearances to avoid burns or clothing ignition. Do Not Touch. Keep children, clothing, and combustible away.
7. Install the heater such that it is not directly exposed to water spray, rain and /or water.
8. Never use in areas normally for habitation and /or where children may be present.
9. Always operate only on a stable, level surface.

# NEVER LEAVE THE HEATER UNATTENDED WHILE BURNING!

10. Do not use with duct work. Do not restrict inlet or exit.
11. Use only with electrical power specified. The electrical connection and grounding must comply with National Electrical Code – ANSI/NFPA 70 (USA) and CSA C22.1 Canadian Electrical Code, Part 1 (Canada).
12. Do not move, handle, or service while hot or in operation.
13. Only move heater by picking it up by the handle.
14. Use only in accordance with local, state (provincial) or national requirements, ordinances and codes.

## Operating Instructions

### UNPACKING

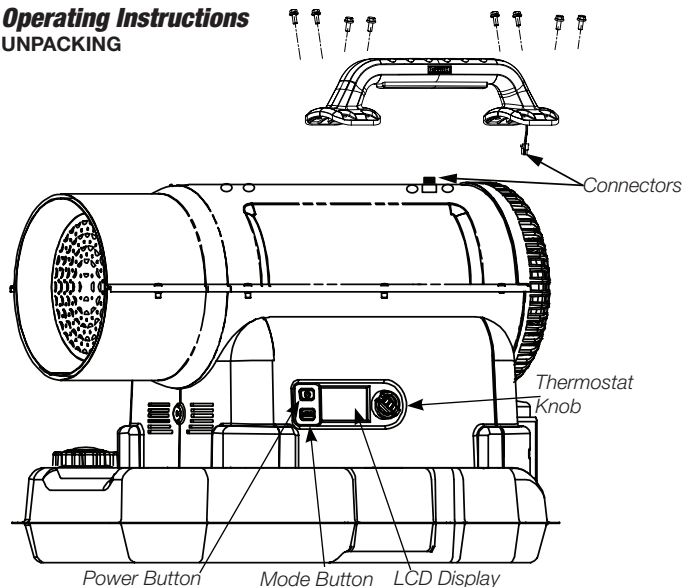

Fig. 1

1. Remove heater from carton.
2. Remove all protective material which may have been applied to the heater for shipment.
3. Check the heater for possible shipping damage. If any damage is found immediately contact the manufacturer at 855-805-5745.

### ASSEMBLY

1. In the hardware package you will find the handle and eight fasteners for attaching it to the top of the heater.
  - a. Plug the electrical connector attached to the handle into the mating connector mounted in the top of the heater.
  - b. Carefully guide the excess wire up into the handle as you center it on the 8 mounting points to attach the handle. See Fig. 1. Make sure to not pinch the wiring between the handle and heater when fastening down.

### PREPARATION FOR OPERATION

1. Ensure that heater does not appear to be damaged. If any is found, immediately contact the manufacturer at 855-805-5745.
2. Charge (Refer to Battery Charging Procedure Section) and insert battery in the rear of the heater or connect heater to 115V AC on the back of heater using an extension cord. Refer to Figure 3 for battery/cord insertion.
3. Follow all WARNINGS and Precautions found in this manual.
4. At extreme temperatures the use of de-icer is recommended.

**IMPORTANT: Before filling fuel tank the first time or after extended storage periods, drain the fuel tank of any moisture or condensation.**

5. **⚠ WARNING:** Locate heater at a safe distance from combustible materials. Not suitable for use on wood floors or other combustible materials. When used, the heater should rest on suitable insulating material at least 1 inch thick and extending 3 ft. or more beyond the heater in all directions.

### HEATER START UP

1. Ensure the heater is plugged in or at least one battery is inserted. While not required, the unit will operate properly if plugged in while battery or batteries are inserted.
2. Press the power button until the LCD screen illuminates. Refer to Fig. 1.
3. Choose the desired MODE by pressing the MODE button. (Unit will default to ECO if no mode is selected - See **MODES** below for more information)
4. Rotate the knob to desired temperature.
5. The heater will continue to run until the set temperature is reached. The thermostat is compensated to avoid constant cycling.

**⚠ WARNING: DO NOT MOVE, HANDLE, OR RELOCATE WHILE HEATER IS ON OR WHEN THERMOSTAT IS IN STANDBY MODE.**

# NEVER LEAVE THE HEATER UNATTENDED WHILE BURNING!

6. Once the heater has reached set temperature the burner will turn off and the cooling cycle will start. The air circulation fan will run for 90-seconds and then the unit will remain idle until there is a call for heat or the thermostat is adjusted.

**NOTE:** If any error codes are encountered, please refer to Page 14.

## MODES: ECO/MAX/ COLD START

1. The Mode button is used to change heating modes. The heater starts up in ECO mode automatically and can be toggled between ECO and MAX using the Mode button.
- ECO mode slightly lowers the heat output to save fuel and provide longer times between fill ups.
- MAX mode increases the heat output to maximum and consumes fuel slightly faster.

## HEATER SHUT DOWN

1. Press the power button
2. The 90 second cooling cycle will begin. Upon completion the heater will turn off.

⚠ **CAUTION:** NEW POWER SOURCES CANNOT BE INSERTED OR REMOVED WHILE HEATER IS RUNNING FOR SAFETY.

**IMPORTANT:** ALWAYS ALLOW THE HEATER TO COMPLETE THE COOLING CYCLE BEFORE REMOVING POWER.

## CONTINUOUS HEAT (CH) FEATURE

The unit runs until out of battery, fuel, or manually turned off.

## COLD START (CS) MODE FEATURE

The heater is equipped with a cold start feature. During extremely cold ambient temperatures, the cold start feature will help the cold fuel to ignite by recirculating cold fuel to warm it and prime the fuel pump. Use under 32°F.

## Empty Fuel Tank Restart

In the event the fuel tank has been emptied while running, use the COLD START (CS) mode to aid in starting the heater.

1. Press the start button and release.
2. Press and hold in the MODE button for 5 seconds to enter the COLD START mode. The fan and fuel pump will run recirculating fuel to prime the fuel pump and warm fuel for 60 seconds and then enter heating mode.

## Li-ion Backup Battery

The system is equipped with an internal Li-ion backup battery cell. The battery is to ensure the heater will complete a cool down cycle after the heater has shut off due to abnormal use. This includes if batteries or the 115V power source is removed while heater is operating.

⚠ **WARNING:** Danger of explosion if battery is incorrectly replaced. When replacing battery, replace it with the same type LG chem. INR 18650 M29 2850mAh cell. Observe correct polarity (+ and -) when replacing battery. Do not store or carry batteries so that metal objects can contact exposed battery terminals.

## Maintenance and Storage

⚠ **WARNING:** Unplug unit and remove DEWALT batteries before performing any maintenance on the heater.

## Daily Maintenance Schedule

1. **GENERAL.** Make general visual inspection of heater for loose or damaged parts. Check nuts and bolts to insure against looseness caused by vibration or rough handling. Damaged parts should be repaired or replaced before using heater again. Check heater operation to be sure it is operating normally (See "Servicing" section for description of normal operation).
2. **FILTERS.** Dirty fuel filters will cause an imbalance in the air-fuel mixture. The best indication that this condition exists is an increase in odors or difficulty getting your heater to ignite. This heater should never be operated without the filter in place. Contact 855-805-5745 for replacement parts.

## Maintenance and Cleaning

1. **REMOVE DUST.** Clean heater twice a season (more often under dusty conditions). Remove accumulated dust from the burner and fan blades with compressed air. Safety glasses should be worn when using compressed air. Wipe area clean with a clean dry cloth. Inspect area to insure all foreign materials are removed, especially around the burner and combustion area.
2. **PHOTO CELL.** Clean the glass portion of the Photo cell with a soft dry cloth.
3. **NOZZLE ADAPTER.** Accumulation of dirt and carbon from the combustion process can eventually fill up the passages in the nozzle adapter, resulting in reduction of fuel and air flow. If this occurs, clean nozzle adapter.

# NEVER LEAVE THE HEATER UNATTENDED WHILE BURNING!

4. **FUEL TANK.** Clean twice a season (during frequently used periods, clean twice a month). Drain and flush the fuel tank with clean fuel oil. Make sure to dispose of waste fuel properly.

## ANNUAL MAINTENANCE SCHEDULE

1. **FUEL FILTER.** Remove the fuel filter from fuel line and direct compressed air through the filter in the opposite direction of fuel flow. Safety glasses should be worn when using compressed air.
2. **FUEL LINES.** If the fuel lines are removed during cleaning, be sure all connections are tight before operating unit. If any dry rotting or cracking in the lines is observed contact 855-805-5745 for service parts.

## STORAGE

- Store the heater in a dry location free from fumes or dust.
- At the end of each heating season, clean the heater as described in the MAINTENANCE section. Drain and flush the fuel tank with clean fuel. The manufacturer recommends completely filling the tank with fuel for extended storage to minimize condensation inside the tank.  
**NOTE:** It is recommended to only store kerosene in containers that are marked "KEROSENE".
- When the heater is stored for long periods of time, it is recommended to leave the heater plugged into a 120V outlet. This will charge and maintain the internal backup battery ensuring optimal performance after storage.

## SERVICING

**⚠WARNING:** A hazardous condition may result if a heater is used that has been modified or is not functioning properly. When the heater is working properly:

- \* The flame is contained within the heater.
- \* The flame is essentially blue with perhaps some yellow tipping.
- \* There is no strong disagreeable odor, eye burning or other physical discomfort.
- \* There is no smoke or soot internal or external to the heater.
- \* There are no unplanned or unexplained shut downs of the heater.

**⚠WARNING:** The parts lists and exploded view show the heater as it was constructed. Do not use a heater which is different from that shown.

When servicing or replacing batteries, please note:

- Do not service the heater with battery connected
- Do not operate a damaged heater.
- Use only DEWALT original battery type.
- Do not dispose of the batteries in a fire. The cell may explode. See "Battery Recycling Information" below.
- Do not open or mutilate the batteries. Released electrolyte is corrosive and may cause damage to the eyes or skin. It may be toxic if swallowed.
- Exercise care in handling batteries in order not to short the battery with conducting materials such as rings, bracelets and/ or keys. The battery and/ or conductor may overheat and cause burns.

## ELECTRICAL PRECAUTIONS

### GROUNDING INSTRUCTIONS

In the event of malfunction or insulation breakdown, grounding provides a path of least resistance for electric current to reduce the risk of electric shock. The heater must be connected to a cord having an equipment-grounding conductor and a grounding plug. The plug must be plugged into an appropriate outlet that is properly installed and grounded in accordance with all local codes and ordinances.

**⚠DANGER:** Improper connection of the equipment grounding conductor can result in a risk of electric shock. The conductor with insulation having an outer surface that is green with or without yellow stripes is the equipment grounding conductor. If repair or replacement of the cord or plug is necessary, do not connect the equipment-grounding conductor to a live terminal. Check with a qualified electrician or service person if the grounding instructions are not completely understood, or if in doubt as to whether the heater is properly grounded. Do not modify the plug connected to the heater – if it will not fit the outlet, have a proper outlet installed by a qualified electrician.



# NEVER LEAVE THE HEATER UNATTENDED WHILE BURNING!

The heater is for use on a nominal 120V circuit, and should be connected to a grounding outlet that looks like that illustrated in Figure 2a. A temporary adaptor, which looks like the adaptor illustrated in Figure 2b, may be used to connect this plug to a 2-pole receptacle as shown in Figure 2b if a properly grounded outlet is not available. The temporary adaptor should be used only until a properly grounded outlet can be installed by a qualified electrician. The green colored rigid ear, lug, and the like, extending from the adaptor must be connected to a permanent ground such as a properly grounded outlet box cover. Whenever the adaptor is used, it must be held in place by the metal screw.

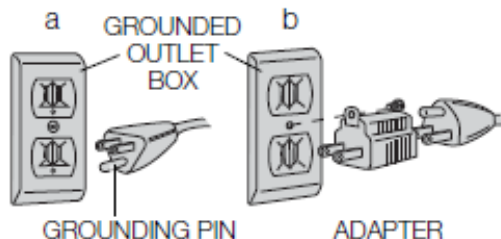

Fig. 2

**NOTE:** IN CANADA, THE USE OF A TEMPORARY ADAPTOR IS NOT PERMITTED BY THE CANADIAN ELECTRICAL CODE. Ensure that the heater is connected to an outlet having the same configuration as the plug.

### ELECTRICAL CONNECTION

This product should be connected to a power supply that is 120 volts, AC only (normal household current), 60 Hz. Do not operate this product on direct current (DC) through the power cord. A substantial voltage drop will cause a loss of power and the motor will overheat. If the product does not operate when plugged into an outlet, double-check the power supply.

### EXTENSION CORDS

When using a product at a considerable distance from a power source, be sure to use an extension cord that has the capacity to handle the current the product will draw. An undersized cord will cause a drop in line voltage, resulting in overheating and loss of power. Use the chart to determine the minimum wire size required in an extension cord. Only round jacketed cords listed by Underwriter's Laboratories (UL) should be used.

\*\*Ampere rating (on product data plate)

Amperes (A)	0-2.0	2.1-3.4	3.5-5.0	5.1-7.0	7.1-12.0	12.1-16.0
Cord Length	Size Wire: American Wire Gauge (AWG)					
25 ft	16	16	16	16	14	14
50 ft	16	16	16	14	14	12
100 ft	16	16	14	12	10	---

\*\*Used on 12 gauge - 20 amp circuit

When using this product outdoors, use an extension cord that is designed for outside use. This type of cord is designated with "WA" or "W" on the cord's jacket.

Before using any extension cord, inspect it for loose or exposed wires and cut or worn insulation.

**⚠WARNING:** Keep the extension cord clear of the working area. Position the cord so that it will not get caught on lumber, tools, or other obstructions while you are working with this product. Failure to do so can result in serious personal injury.

**⚠WARNING:** Check extension cords before each use. If damaged replace immediately. Never use a product with a damaged cord since touching the damaged area could cause electrical shock resulting in serious injury.



# NEVER LEAVE THE HEATER UNATTENDED WHILE BURNING!

**⚠WARNING:** To reduce the risk of electric shock, use only with an extension cord intended for outdoor use, such as an extension cord of cord type SW-A, SOW-A, STW-A, STOW-A, SJW-A, SJOW-A, SJTW-A. or SJTOW-A.

## IMPORTANT SAFETY INSTRUCTIONS FOR ALL BATTERY CHARGERS

**SAVE THESE INSTRUCTIONS:** This manual contains important safety and operating instructions for battery chargers.

**NOTICE:** The heater does not serve as a battery charger.

- Before using the charger, read all instructions and cautionary markings on the charger, battery pack and product using the battery pack.

**⚠WARNING:** Shock hazard. Do not allow any liquid to get inside the charger. Electric shock may result.

**⚠WARNING:** Burn hazard. To reduce the risk of injury, charge only DeWALT rechargeable battery packs.

**⚠CAUTION:** Other types of batteries may overheat and burst resulting in personal injury and property damage.

**NOTICE:** Under certain conditions, with the charger plugged into the power supply, the charger can be shorted by foreign material. Foreign materials of a conductive nature, such as, but not limited to, grinding dust, metal chips, steel wool, aluminum foil or any buildup of metallic particles should be kept away from the charger cavities. Always un-plug the charger from the power supply when there is no battery pack in the cavity. Unplug the charger before attempting to clean it.

**⚠WARNING:**

- **DO NOT attempt to charge the battery pack with any chargers other than the ones in this manual.** The charger and battery pack are specifically designed to work together.
- **These chargers are not intended for any uses other than charging DeWALT rechargeable batteries.** Any other uses may result in risk of fire, electric shock or electrocution.
- **Do not expose the charger to rain or snow.**
- **Pull by the plug rather than the cord when disconnecting the charger.** This will reduce the risk of damage to the electric plug and cord.

- **Make sure that the cord is located so that it will not be stepped on, tripped over or otherwise subjected to damage or stress.**
- **Do not use an extension cord unless it is absolutely necessary.** Use of improper extension cord could result in risk of fire, electric shock or electrocution.
- **When operating a charger outdoors, always provide a dry location and use an extension cord suitable for outdoor use.** Use of a cord suitable for outdoor use reduces the risk of electric shock.
- **An extension cord must have adequate wire size (AWG or American Wire Gauge) for safety.** The smaller the gauge number of the wire, the greater the capacity of the cable, that is, 16 gauge has more capacity than 18 gauge. An undersized cord will cause a drop in line voltage resulting in loss of power and overheating. When using more than one extension to make up the total length, be sure each individual extension contains at least the minimum wire size. The following table shows the correct size to use depending on cord length and nameplate ampere rating. If in doubt, use the next heavier gauge. The lower the gauge number, the heavier the cord.
- **Do not place any object on top of the charger or place the charger on a soft surface that might block the ventilation slots and result in excessive internal heat.** Place the charger in a position away from any heat source. The charger is ventilated through slots in the top and the bottom of the housing.
- **Do not operate the charger with a damaged cord or plug.**
- **Do not operate the charger if it has received a sharp blow, been dropped or otherwise damaged in any way.** Take it to an authorized service center.
- **Do not disassemble the charger; take it to an authorized service center when service or repair is required.** Incorrect reassembly may result in a risk of electric shock, electrocution or fire.
- **Disconnect the charger from the outlet before attempting any cleaning. This will reduce the risk of electric shock.** Removing the battery pack will not reduce this risk.
- **NEVER attempt to connect 2 chargers together.**
- **The charger is designed to operate on standard 115V household electrical power. Do not attempt to use it on any other voltage.** This does not apply to the vehicular charger.

# NEVER LEAVE THE HEATER UNATTENDED WHILE BURNING!

## Regulatory Notices

- This Class B digital apparatus complies with Canadian ICES-003.
- This device complies with Part 15 of the FCC Rules and Industry Canada License-exempt RSS standard(s). Operation is subject to the following two conditions:

- 1) This device may not cause harmful interference, and
- 2) This device must accept any interference received, including interference that may cause undesired operation.

- Changes or modifications not expressly approved by the party responsible for compliance could void the user's authority to operate the equipment.

**NOTE:** This equipment has been tested and found to comply with the limits for a Class B digital device, pursuant to Part 15 of the FCC Rules. These limits are designed to provide reasonable protection against harmful interference in a residential installation. This equipment generates, uses and can radiate radio frequency energy and, if not installed and used in accordance with the instructions, may cause harmful interference to radio communications. However, there is no guarantee that interference will not occur in a particular installation. If this equipment does cause harmful interference to radio or television reception, which can be determined by turning the equipment off and on, the user is encouraged to try to correct the interference by one or more of the following measures:

- Reorient or relocate the receiving antenna.
- Increase the separation between the equipment and receiver.
- Connect the equipment into an outlet on a circuit different from that to which the receiver is connected.
- Consult the dealer or an experienced radio/TV technician for help.

## Introduction

The DCB107, DCB115 battery charger is designed to charge DeWALT 12–20V Max\* lithium ion battery packs. This charger requires no adjustment and is designed to be as easy as possible to operate. Simply place your battery pack into a receptacle of a plugged in charger and it will automatically charge the pack. Consult the chart at the end of this manual for compatibility of chargers and battery packs.

## IMPORTANT SAFETY INSTRUCTIONS FOR ALL BATTERY PACKS

When ordering replacement battery packs, be sure to include the catalog number and voltage. Consult the chart at the end of this manual for compatibility of chargers and battery packs.

The battery pack is not fully charged out of the carton. Before using the battery pack and charger, read the safety instructions below and then follow charging procedures outlined.

## READ ALL INSTRUCTIONS

### ⚠WARNING:

- **Do not charge or use the battery pack in explosive atmospheres, such as in the presence of flammable liquids, gases or dust.** Inserting or removing the battery pack from the charger may ignite the dust or fumes.
- **NEVER force the battery pack into the charger. DO NOT modify the battery pack in any way to fit into a non-compatible charger as battery pack may rupture causing serious personal injury.** Consult the chart at the end of this manual for compatibility of batteries and chargers.
- Charge the battery packs only in designated DeWALT chargers.
- **DO NOT** splash or immerse in water or other liquids.
- **Do not store or use the tool and battery pack in locations where the temperature may reach or exceed 104 °F (40 °C) (such as outside sheds or metal buildings in summer).** For best life store battery packs in a cool, dry location. **NOTE: Do not store the battery pack in a tool with the trigger switch locked on. Never tape the trigger switch in the ON position.**

⚠WARNING: Fire hazard. Never attempt to open the battery pack for any reason. If the battery pack case is cracked or damaged, do not insert into the charger. Do not crush, drop or damage the battery pack. Do not use a battery pack or charger that has received a sharp blow, been dropped, run over or damaged in any way (e.g., pierced with a nail, hit with a hammer, stepped on). Damaged battery packs should be returned to the service center for recycling.

# NEVER LEAVE THE HEATER UNATTENDED WHILE BURNING!

**△WARNING: Fire hazard. Do not store or carry the battery pack so that metal objects can contact exposed battery terminals.** For example, do not place the battery pack in aprons, pockets, tool boxes, product kit boxes, drawers, etc., with loose nails, screws, keys, etc. **Transporting batteries can possibly cause fires if the battery terminals inadvertently come in contact with conductive materials such as keys, coins, hand tools and the like.** The US Department of Transportation Hazardous Material Regulations (HMR) actually prohibit transporting batteries in commerce or on airplanes (e.g., packed in suitcases and carry-on luggage) UNLESS they are properly protected from short circuits. So when transporting individual battery packs, make sure that the battery terminals are protected and well insulated from materials that could contact them and cause a short circuit.

## SPECIFIC SAFETY INSTRUCTIONS FOR LITHIUM ION (Li-Ion)

- **Do not incinerate the battery pack even if it is severely damaged or is completely worn out.** The battery pack can explode in a fire. Toxic fumes and materials are created when lithium ion battery packs are burned.
- **If battery contents come into contact with the skin, immediately wash area with mild soap and water.** If battery liquid gets into the eye, rinse water over the open eye for 15 minutes or until irritation ceases. If medical attention is needed, the battery electrolyte is composed of a mixture of liquid organic carbonates and lithium salts.
- **Contents of opened battery cells may cause respiratory irritation.** Provide fresh air. If symptoms persist, seek medical attention.

**△WARNING: Burn hazard. Battery liquid may be flammable if exposed to spark or flame.**



## The RBRC® Seal

The RBRC® (Rechargeable Battery Recycling Corporation) Seal on the nickel cadmium, nickel metal hydride or lithium-ion batteries (or battery packs) indicates that the costs to recycle these batteries (or battery packs) at the end of their useful life have already been paid by DeWALT. In some areas, it is illegal to place spent nickel cadmium, nickel metal hydride or lithium-ion batteries in the trash or municipal solid waste stream and the Call 2 Recycle® program provides an environmentally conscious alternative.

Call 2 Recycle, Inc., in cooperation with DeWALT and other battery users, has established the program in the United States and Canada to facilitate the collection of spent nickel cadmium, nickel metal hydride or lithium-ion batteries. Help protect our environment and conserve natural resources by returning the spent nickel cadmium, nickel metal hydride or lithium-ion batteries to an authorized DeWALT service center or to your local retailer for recycling. You may also contact your local recycling center for information on where to drop off the spent battery. RBRC® is a registered trademark of Call 2 Recycle, Inc.

## Charger

Be sure to read all safety instructions before using your charger. Consult the chart at the end of this manual for compatibility of chargers and battery packs.

## Charging a Battery (Fig. 3)

1. Plug the charger into a FIG. 3 appropriate outlet before inserting battery pack.
2. Insert the battery pack into the charger, making sure the battery pack is fully seated in the charger. The red (charging) light will blink continuously indicating that the charging process has started.
3. The completion of charge will be indicated by the red light remaining ON continuously. The battery pack is fully charged and may be used at this time or left in the charger.

**NOTE:** To ensure maximum performance and life of lithium-ion battery packs, charge the battery pack fully before first use.

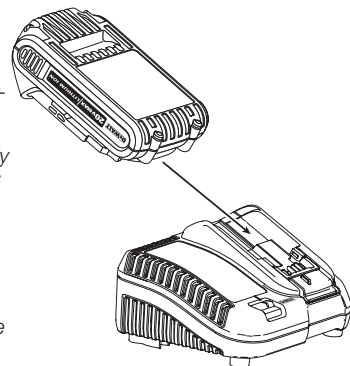



Fig. 3

# NEVER LEAVE THE HEATER UNATTENDED WHILE BURNING!

## Charger Operation

Refer to the indicators below for the charge status of the battery pack.

CHARGE INDICATORS			
	CHARGING	--- ---	
	FULLY CHARGED	————	
	HOT/COLD PACK DELAY	--- ---	

\* The red light will continue to blink, but a yellow indicator light will be illuminated during this operation. Once the battery pack has reached an appropriate temperature, the yellow light will turn off and the charger will resume the charging procedure.

The charger will not charge a faulty battery pack. The charger will indicate faulty battery pack by refusing to light.

**NOTE:** This could also mean a problem with a charger.

If the charger indicates a problem, take the charger and battery pack to be tested at an authorized service center.

## HOT/COLD PACK DELAY

When the charger detects a battery pack that is too hot or too cold, it automatically starts a Hot/Cold Pack Delay, suspending charging until the battery pack has reached an appropriate temperature. The charger then automatically switches to the pack charging mode. This feature ensures maximum battery pack life.

A cold battery pack will charge at a slower rate than a warm battery pack. The battery pack will charge at that slower rate throughout the entire charging cycle and will not return to maximum charge rate even if the battery pack warms.

## LITHIUM-ION BATTERY PACKS ONLY

Li-Ion tools are designed with an Electronic Protection System that will protect the battery pack against overloading, overheating or deep discharge.

The tool will automatically turn off if the Electronic Protection System engages. If this occurs, place the lithium-ion battery pack on the charger until it is fully charged.

## Important Charging Notes

1. Longest life and best performance can be obtained if the battery pack is charged when the air temperature is between 65 °F and 75 °F (18° – 24 °C). DO NOT charge the battery pack in an air temperature below +40 °F (+4.5 °C), or above +104 °F (+40 °C). This is important and will prevent serious damage to the battery pack.
2. The charger and battery pack may become warm to the touch while charging. This is a normal condition, and does not indicate a problem. To facilitate the cooling of the battery pack after use, avoid placing the charger or battery pack in a warm environment such as in a metal shed or an uninsulated trailer.
3. If the battery pack does not charge properly:
  - Check operation of the receptacle by plugging in a lamp or other appliance;
  - Check to see if the receptacle is connected to a light switch which turns the power off when you turn out the lights;
  - Move the charger and battery pack to a location where the surrounding air temperature is approximately 65 °F – 75 °F (18° – 24 °C);
  - If charging problems persist, take the tool, battery pack and charger to your local service center.
4. The battery pack should be recharged when it fails to produce sufficient power on jobs which were easily done previously. DO NOT CONTINUE to use it under these conditions. Follow the charging procedure. You may also charge a partially used pack whenever you desire with no adverse effect on the battery pack.
5. Foreign materials of a conductive nature such as, but not limited to, grinding dust, metal chips, steel wool, aluminum foil, or any buildup of metallic particles should be kept away from charger cavities. Always unplug the charger from the power supply when there is no battery pack in the cavity. Unplug the charger before attempting to clean it.
6. Do not freeze or immerse the charger in water or any other liquid.  
**⚠WARNING:** Shock hazard. Don't allow any liquid to get inside the charger. Electric shock may result.  
**⚠WARNING:** Burn hazard. Do not submerge the battery pack in any liquid or allow any liquid to enter the battery pack. Never attempt to open the battery pack for any reason. If the plastic housing of the battery pack breaks or cracks, return it to a service center for recycling.

# NEVER LEAVE THE HEATER UNATTENDED WHILE BURNING!

## Wall Mounting

These chargers are designed to be wall mountable or to sit upright on a table or work surface. If wall mounting, locate the charger within reach of an electrical outlet, and away from a corner or other obstructions which may impede air flow. Use the back of the charger as a template for the location of the mounting screws on the wall. Mount the charger securely using drywall screws (purchased separately) at least 1" (25.4 mm) long, with a screw head diameter of 0.28–0.35" (7–9 mm), screwed into wood to an optimal depth leaving approximately 7/32" (5.5 mm) of the screw exposed. Align the slots on the back of the charger with the exposed screws and fully engage them in the slots.

## Charger Cleaning Instructions

**⚠WARNING:** Shock hazard. Disconnect the charger from the AC outlet before cleaning. Dirt and grease may be removed from the exterior of the charger using a cloth or soft non-metallic brush. Do not use water or any cleaning solutions.

## Storage Recommendations

1. The best storage place is one that is cool and dry, away from direct sunlight and excess heat or cold.
2. For long storage, it is recommended to store a fully charged battery pack in a cool dry place out of the charger for optimal results.

**NOTE:** Battery packs should not be stored completely depleted of charge. The battery pack will need to be recharged before use.

## SAVE THESE INSTRUCTIONS FOR FUTURE USE

## Repairs

The charger and battery pack are not serviceable. There are no serviceable parts inside the charger or battery pack.

## READ ALL OF THE INSTRUCTIONS IN THE BATTERY CHARGER SECTION OF THIS MANUAL BEFORE ATTEMPTING TO CHARGE THE BATTERY PACK FOR YOUR TOOL.

If you have any questions, call 855-805-5745.

Register Online

Thank you for your purchase. Register your product now for:

- **WARRANTY SERVICE:** Registering your product will help you obtain more efficient warranty service in case there is a problem with your product.
- **CONFIRMATION OF OWNERSHIP:** In case of an insurance loss, such as fire, flood or theft, your registration of ownership will serve as your proof of purchase.

- **FOR YOUR SAFETY:** Registering your product will allow us to contact you in the unlikely event a safety notification is required under the Federal Consumer Safety Act. Register Online at [www.DEWALT.com/register](http://www.DEWALT.com/register).

## Battery and Charger Three Year Limited Warranty

DEWALT will repair, without charge, any defects due to faulty materials or workmanship for three years from the date of purchase. This warranty does not cover part failure due to normal wear or tool abuse. For further detail of warranty coverage and warranty repair information, visit [www.DEWALT.com](http://www.DEWALT.com) or call 855-805-5745. This warranty does not apply to accessories or damage caused where repairs have been made or attempted by others. This warranty gives you specific legal rights and you may have other rights which vary in certain states or provinces.

In addition to the warranty, DEWALT tools are covered by our:

### 1 YEAR FREE SERVICE

DEWALT will maintain the tool and replace worn parts caused by normal use, for free, any time during the first year after purchase.

### 2 YEARS FREE SERVICE ON DEWALT BATTERY PACKS

DC9071, DC9091, DC9096, DC9182, DC9280, DC9360,  
DCB120, DCB127, DCB201, DCB203, DCB203BT, DCB207, DCB361

### 3 YEARS FREE SERVICE ON DEWALT BATTERY PACKS

DCB200, DCB204, DCB204BT, DCB205, DCB606

DEWALT BATTERY PACKS

Product warranty voided if the battery pack is tampered with in any way. DEWALT is not responsible for any injury caused by tampering and may prosecute warranty fraud to the fullest extent permitted by law.

90 DAY MONEY BACK GUARANTEE

If you are not completely satisfied with the performance of your DEWALT Power Tool, Laser, or Nailer for any reason, you can return it within 90 days from the date of purchase with a receipt for a full refund – no questions asked.

**LATIN AMERICA:** This warranty does not apply to products sold in Latin America. For products sold in Latin America, see country specific warranty information contained in the packaging, call the local company or see website for warranty information.

**FREE WARNING LABEL REPLACEMENT:** If your warning labels become illegible or are missing, call 855-805-5745 for a free replacement.

# NEVER LEAVE THE HEATER UNATTENDED WHILE BURNING!

## Display Screen

Room/Set Temp

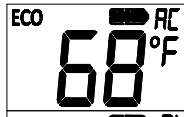
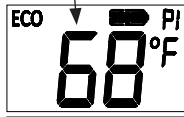

Mode

Mode

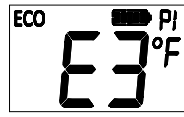

System Communication Failure

\* E1 - E9 Refer to Chart on Next Page

Battery Gauge Pack 1 (or Pack 2)

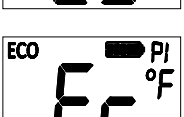
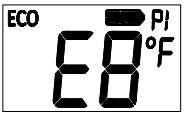

Fuel Pump Failure

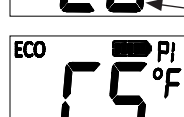
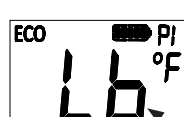

Cold Start Mode

Continuous Heat

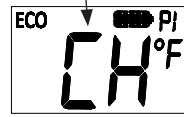

Low Battery Shutdown

Low Fuel Shutdown

Ambient Temp below 23°F

Relocation Detection Switch Error



Li Ion Temperature Sensor Error



1. Battery Pack Position 1 (P1)
2. Battery Pack Position 2 (P2)
3. AC 115v Plug (AC)

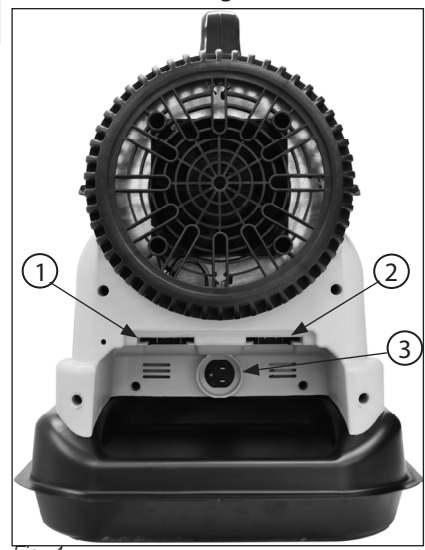

Fig. 4

English



# NEVER LEAVE THE HEATER UNATTENDED WHILE BURNING!

## **Diagnostic Safety Shutdown and Trouble Shooting**

<b>ERROR CODE</b>	<b>DESCRIPTION</b>	<b>REASON</b>	<b>RESOLUTION</b>
E0	Relocation Detection Switch Error (Unit may go through 90 second cooldown)	1. Heater moved while in operation or stand-by mode.	1. Restart unit. 2. If problem persists, contact customer service.
E1	Photo cell error	3. The Photo cell is defective. 4. Flame present before ignition. 5. Extreme ambient light.	1. Have service center clean Photo cell/ replace. 2. Remove any liquid fuel buildup from combustion chamber that may burn. 3. Rotate heater away from direct bright light.
E2	Ambient temperature sensor error	1. Ambient temperature sensor loose. 2. Ambient temperature sensor defective.	1. Have service center check sensor connection. 2. Have service center replace sensor.
E3	HLS (High limit switch) Error	1. High limit switch has activated. 2. HLS defective.	1. Allow unit to cool down for 15 minutes and retry. 2. Have service center replace HLS.
E4	Ignition failure	1. No fuel burning after ignition attempt. 2. Weak or no spark 3. Fuel Issue	1. Fill fuel tank. 2. Contact customer service. 3. Replace fuel or contact customer service.
E5	Fan failure	1. Fan blocked. 2. Contaminated. 3. Defective.	1. Remove blockage. 2. Clean dust/debris. 3. Have service center replace fan.
E6	Power Supply failure.	1. Main board failure.	1. Have service center replace Main pcba.
E7	Backup battery boost converter failure.	1. BMS (Battery Management System) board failure.	1. Have service center replace BMS pcba.
E8	14-21V failure	1. BMS board failure.	1. Restart unit. 2. Have service center replace BMS pcba.



# NEVER LEAVE THE HEATER UNATTENDED WHILE BURNING!

English

ERROR CODE	DESCRIPTION	REASON	RESOLUTION
E9	Backup battery failure	1. Li-ion backup battery disconnected or defective.	1. Check Li-ion battery connection. 2. Replace with OEM battery only (use of any other battery other than the OEM battery may damage heater). <b>⚠WARNING:</b> Danger of explosion if battery is incorrectly replaced. When replacing battery, replace it with the same type LG chem. INR 18650 M29 2850mAh cell. Observe correct polarity (+ and -) when replacing battery. Do not store or carry batteries so that metal objects can contact exposed battery terminals.
EP	Fuel pump failure	1. Fuel pump defective.	1. Have service center replace fuel pump.
EC	System communication failure	1. Wire harness issue. 2. BMS board failure.	1. Have service center check wire harness connection from LCD display board to BMS board. 2. Have service center replace BMS board.
Lb	Low battery shutdown	1. Heater has shut down due to low battery energy.	1. Insert battery with sufficient energy.
LF	Low Fuel Shutdown	1. Insufficient fuel.	1. Fill fuel tank.
CS	Cold Start Mode	1. The cold start sequence is running.	1. Wait for heater to start.
SE	Li Ion Temperature Sensor Error	1. Temperature sensor malfunction.	1. Restart unit. 2. If problem persists, contact customer service.
Flashing Battery Outline	1 bar	Solid bars indicate how much energy is left in a battery pack. This is dependent on the battery pack rated Ah capacity.	
	2 bar		
	3 bar		
	4 bar		
	5 bar		
	Low battery indicator flash	Battery energy is very low.	

**NEVER LEAVE THE HEATER UNATTENDED WHILE BURNING!**

***DXH90CFAK/ DXH90CFAM***

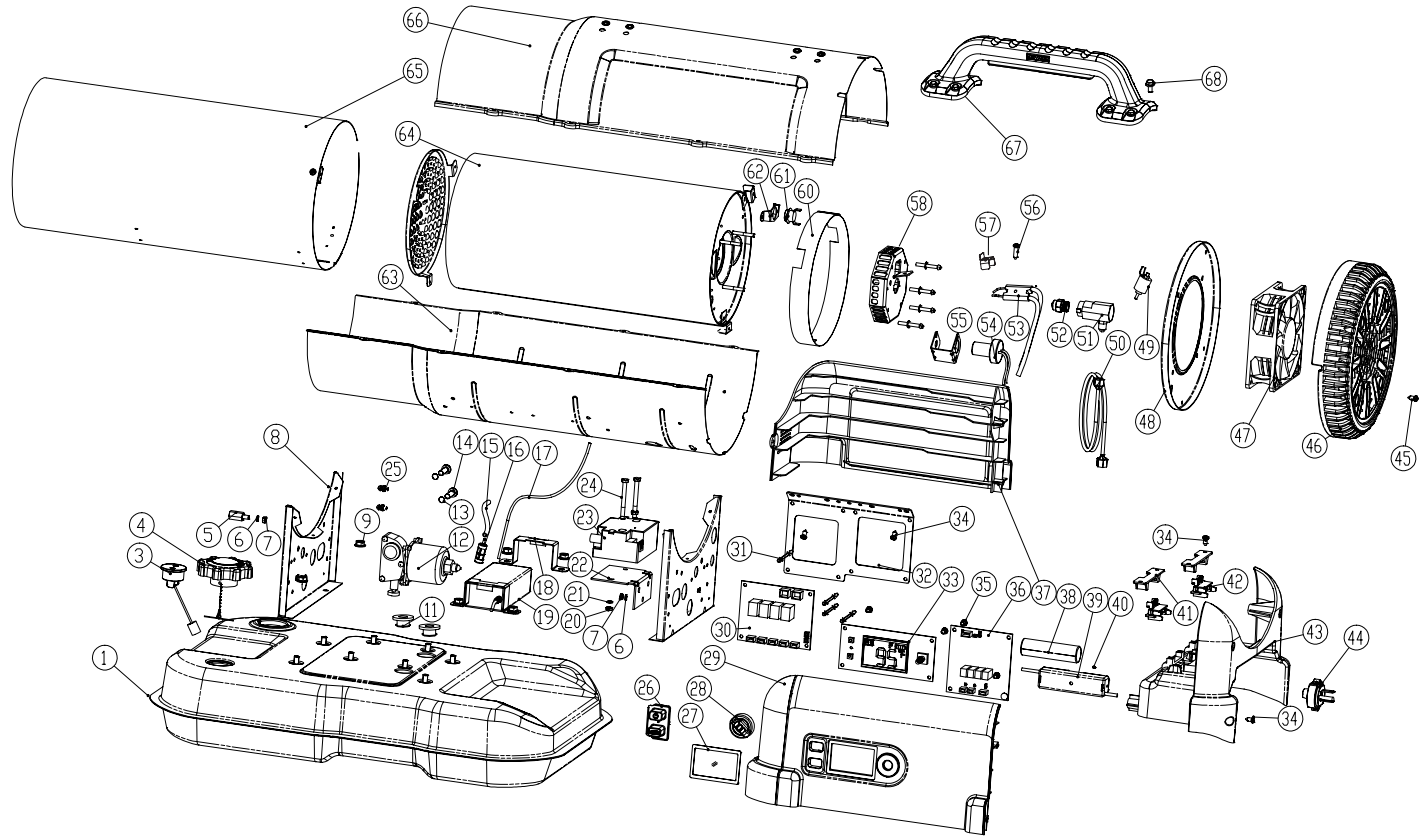

**English**

# NEVER LEAVE THE HEATER UNATTENDED WHILE BURNING!

## REPLACEMENT PARTS LIST

#	P/N	DESC.	QTY
1	27301	Fuel Tank	1
3	27177	Fuel Gauge	1
4	26959	Fuel Tank Cap	1
5	N/A	Bolt	1
6	N/A	Spring Washer	20
7	N/A	Nut	20
8	N/A	Saddle	2
9	N/A	Hex Flange Nut	8
11	N/A	Rubber Seat	2
12	27302	Electromagnetic Pump	1
13	N/A	Spring Washer	2
14	N/A	Pan Head Screw	2
15	27303	Input Fuel Pipe	1
16	27304	Fuel Filter	1
17	27305	Back Pipe	1
18	N/A	Adapter Bracket	2
19	27306	Power Adapter, 115V	1
20	N/A	Nut	2
21	N/A	Spring Washer	2
22	N/A	Ignition Transformer Bracket	1
23	27307	Ignition Transformer	1
24	N/A	Pan Head Bolt	2

#	P/N	DESC.	QTY
26	27308	Rubber Key	1
27	27309	LCD Window	1
28	27310	Temp. Adjustment Knob	1
29	27311	Left Saddle Panel	1
30	27312	Main Control Board	1
31	N/A	PCBA Fit	8
32	N/A	PCBA Bracket	1
33	27313	LCD Display	1
34	N/A	Pan Head Self-Tapp. Screw	20
35	N/A	Pan Head Screw	16
36	27314	BMS	1
37	27315	Right Saddle Panel	1
38	27316	Backup Battery †	1
39	N/A	Backup Battery Holder	1
40	N/A	Pan Head Self-Tap Screw	1
41	27317	Connector Holder	2
42	27318	Connector	2
43	27319	Rear Saddle Panel	1
44	27320	AC Plug	1
45	N/A	Pan Head Self-Tap Screw	8
46	27321	Rear Guard	1
47	27322	Fan	1

#	P/N	DESC.	QTY
48	27323	Fan Bracket	1
49	27324	Solenoid Valve	1
50	27325	Fuel Pipe	1
51	27326	Nozzle Holder	1
52	27327	Nozzle	1
53	27328	Electrode	1
54	27329	Photo Cell Assy.	1
55	27330	Photo Cell Assy. Bracket	1
56	N/A	Pan Head Bolt	1
57	N/A	Electrode Bracket	1
58	27332	Nozzle Bracket Assembly	1
60	27334	Rear Air Guide Ring	1
61	27335	High Limit Switch	1
62	27342	High Limit Switch Bracket	1
63	27337	Bottom Barrel Shell	1
64	27338	Inner Barrel Assy.	1
65	27343	Raditional Shield	1
66	27340	Top Barrel Shell	1
67	27351	Handle Assembly	1
68	N/A	Hex Flange Bolt	8

† Use OEM Part Only

# NEVER LEAVE THE HEATER UNATTENDED WHILE BURNING!

## WIRING DIAGRAM

**⚠WARNING:** The parts lists and wiring diagram show the heater as it was constructed. Do not use a heater which is different from that shown. A heater which is not working right must be repaired, but only by a trained, experienced service person.

English

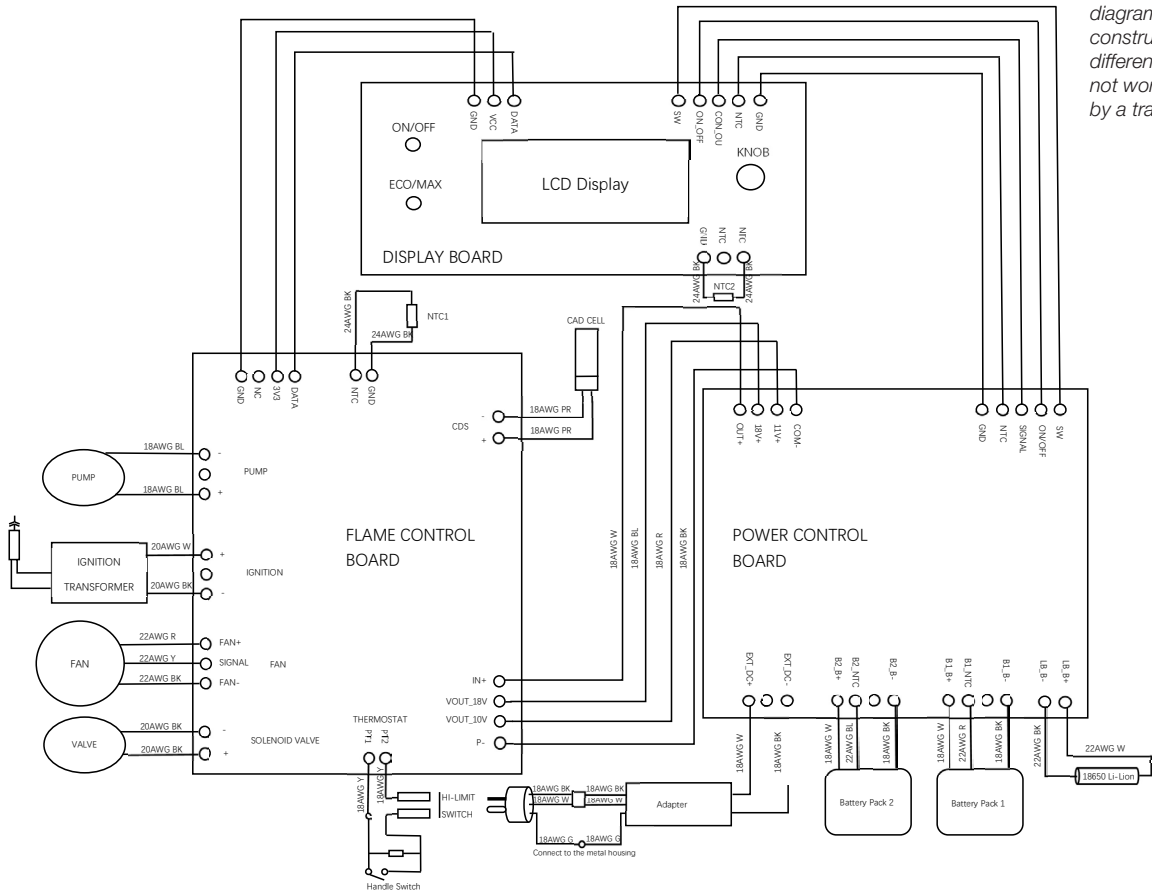

**NEVER LEAVE THE HEATER UNATTENDED WHILE BURNING!**

English

# DEWALT®

## INSTRUCTION MANUAL

**Cordless Kerosene Forced Air Heater**  
DXH90CFAK, DXH90CFAKM

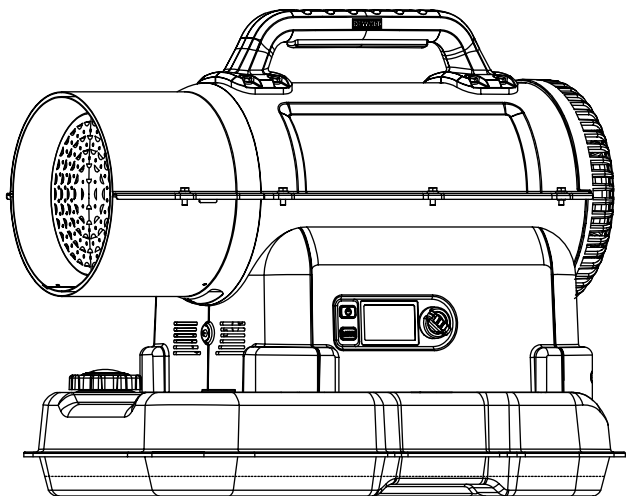

### **▲Warning**

USE ONLY MANUFACTURER'S REPLACEMENT PARTS. USE OF ANY OTHER PARTS COULD CAUSE INJURY OR DEATH. REPLACEMENT PARTS ARE ONLY AVAILABLE DIRECT FROM THE FACTORY AND MUST BE INSTALLED BY A QUALIFIED SERVICE AGENCY.

### **PARTS ORDERING INFORMATION:**

*PURCHASING:* Accessories may be purchased at any DEWALT® local dealer or direct from the factory

### **FOR INFORMATION REGARDING SERVICE:**

Please call Toll-Free 855-805-5745  
[www.DEWALT.com](http://www.DEWALT.com)

Our office hours are 8:00 AM – 5:00 PM, EST, Monday through Friday.

Please include the model number, date of purchase, and description of problem in all communication.

### **LIMITED WARRANTY**

*The manufacturer warrants its heaters and accessories to be free from defects in material and workmanship for a period of 3 years from date of purchase. The manufacturer will repair or replace this product free of charge if it has been prove to be defective within the 3 year period, and is returned at customer expense with proof of purchase to manufacturer within the warranty period.*

DEWALT®, GUARANTEED TOUGH® and the yellow and black color scheme are trademarks of the DEWALT Industrial Tool Co., used under license. ©2023 DEWALT. EGI/Enerco Group Inc. Under license from DEWALT Industrial Tool Co.



UL 733 Fifth Edition, Dated May2, 2019  
CSA B140.8-1967 (R2020)  
CSA B140.0-03 (R2018)