



GOLF CART CARGO BASKET ASSEMBLY

Compatible with PDG 4 Seat Electric Golf Cart # WH2020ASZ-MB

Part # GCB01

ITEM	PART NUMBER	DESCRIPTION	QUANTITY
1	—	Cargo Basket	1
2	Q40106	Cargo Basket Support Brackets	2
3	Q40108	M8 Flat Washers	16
4	Q2724840	M8 x 40 Pan-Head Machine Screws	8
5	Q40308	Lock Washers	8
6	Q340B08	M8 x 1.25 Hex Domed Nut Caps	8

This Cargo Basket accessory installs under the windscreen on the front of the wind screen support frame. Use the pre-drilled holes on the front wind screen support frame to attached the Cargo Basket Support Brackets.

NOTE: A Phillips Screwdriver and a 13mm wrench will be a required to tighten the Screws and Hex Nuts.

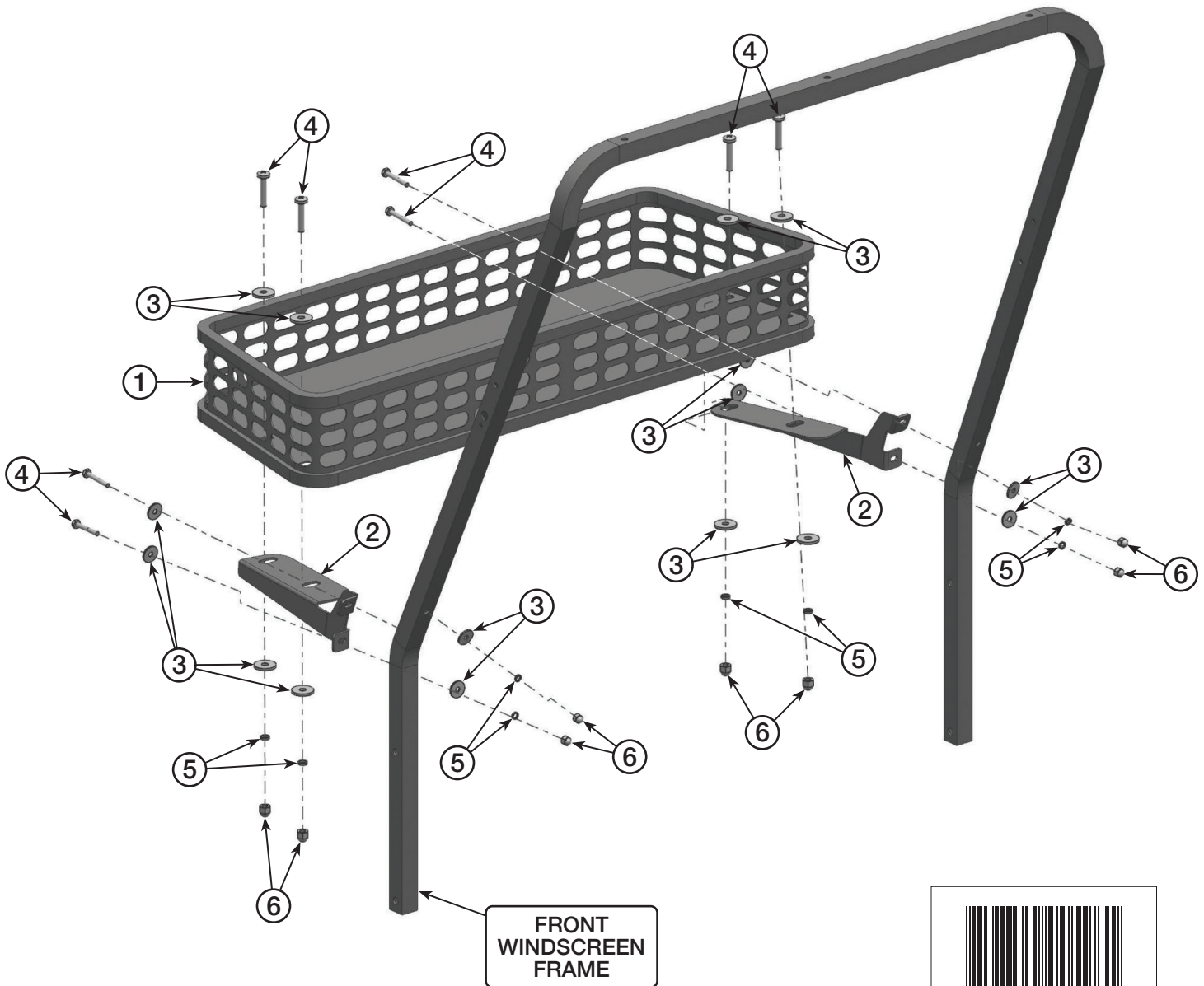

CUSTOMER SERVICE

Plastic Development Group, LLC 24445 Northwestern Hwy, Suite 101 Southfield, MI 48075

833-953-1758

Sales@PDGmail.com



GOLF CART CARGO BASKET ASSEMBLY

Compatible with PDG 4 Seat Electric Golf Cart # WH2020ASZ-MB

Part # GCB01

GCB01 CARGO BASKET ASSEMBLY INSTRUCTIONS

STEP 1: ATTACH SUPPORT BRACKETS TO FRAME

- **NOTE:** Holes to attach Support Brackets to Front Windscreen Frame are pre-drilled below the windscreen.
- With Support Brackets (2) orientated as shown in the illustration on the previous page, align holes in the Support Brackets with holes pre-drilled in the Front Windscreen Frame.
- For each Support Bracket (2), thread 2 M8 x 40 Pan-Head Machine Screws (4) through M8 Flat Washers (3) and insert from front to back through holes in the Support Bracket and Front Windscreen Frame.
- On the back side of the Front Windscreen Frame, secure each M8 x 40 Pan-Head Machine Screw (4) with an M8 Flat Washer (3), M8 Lock Washer (5) and M8 x 1.25 Hex Domed Nut Cap (6).

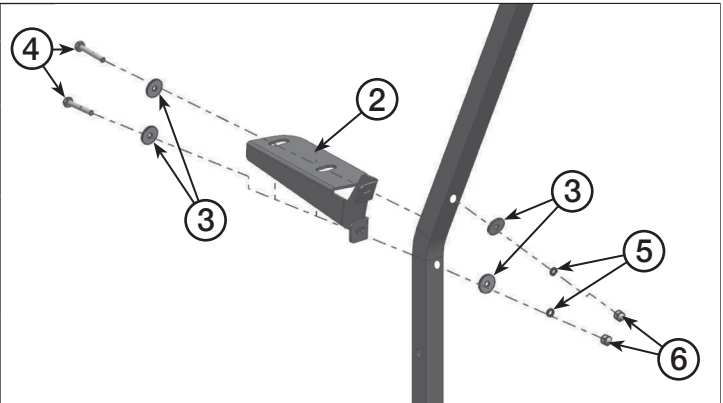

Repeat the above process to install both Brackets securely to the windscreen frame.

STEP 2: ATTACH STORAGE BASKET TO SUPPORT BRACKETS

- Align holes on bottom of Storage Basket (1) with Holes on Support Brackets (2).
- For each Support Bracket (2), thread 2 M8 x 40 Pan-Head Machine Screws (4) through M8 Flat Washers (3) and insert from top to bottom through holes in the Storage Basket (1) and Support Brackets (2).
- On the Storage Basket (1), secure each M8 x 40 Pan-Head Machine Screw (4) with an M8 Flat Washer (3), M8 Lock Washer (5) and M8 x 1.25 Hex Domed Nut Cap (6).

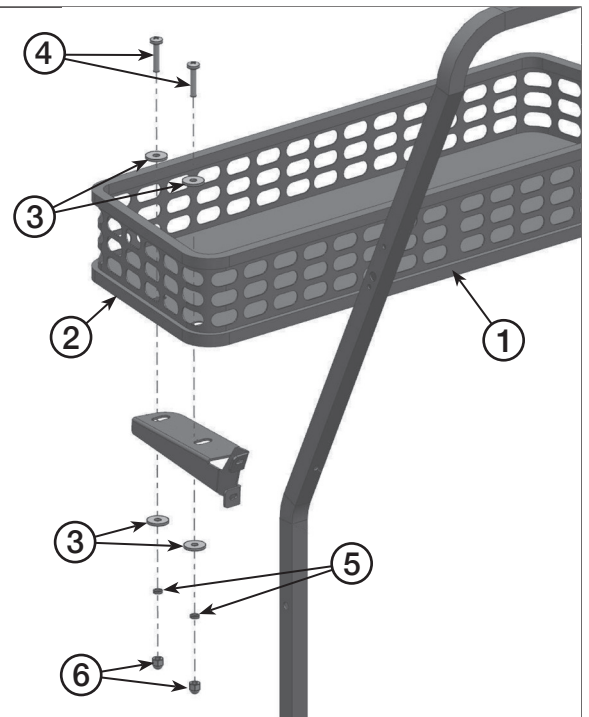

NOTE: A Phillips Screwdriver and a 13mm wrench will be a required to tighten the Screws and Hex Nuts.

CUSTOMER SERVICE

Plastic Development Group, LLC 24445 Northwestern Hwy, Suite 101 Southfield, MI 48075



833-953-1758



Sales@PDGmail.com