

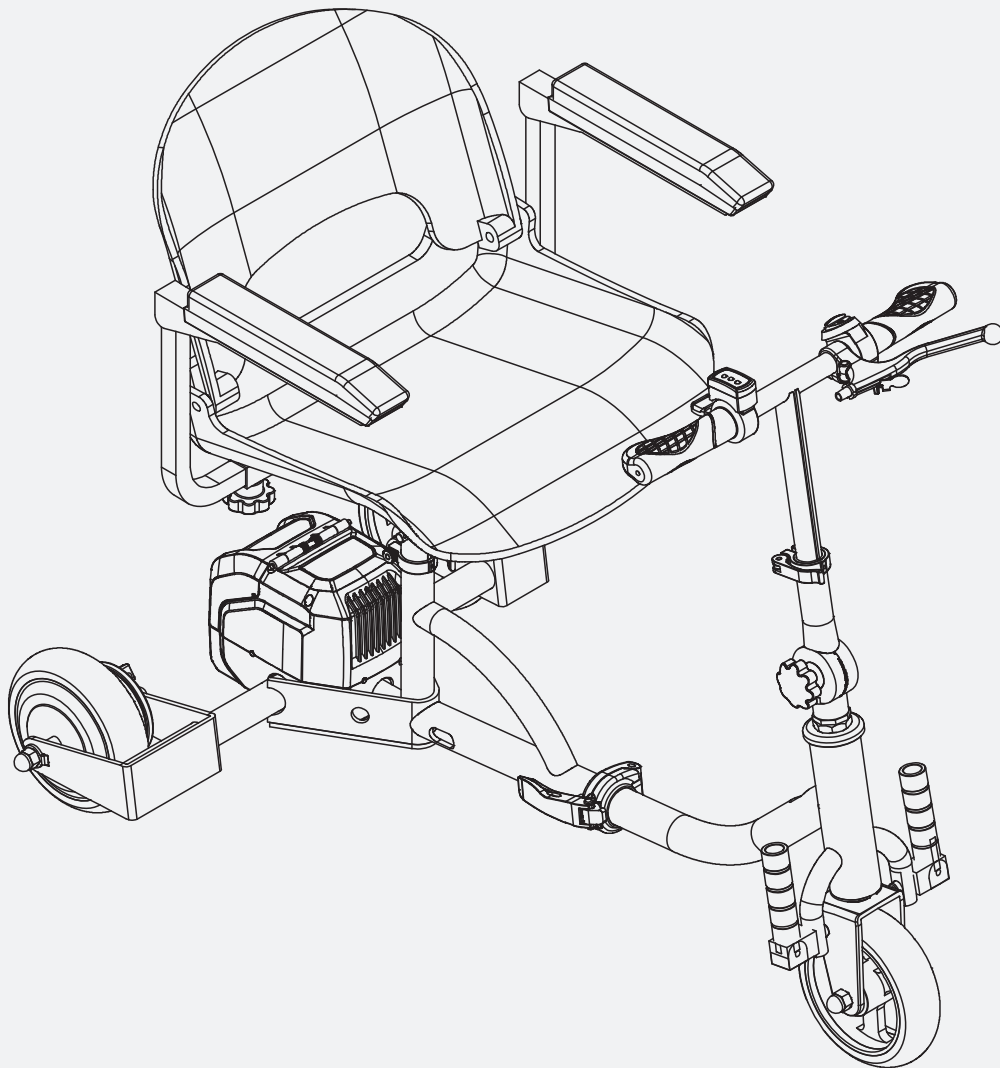

Mobility Scooter | GUT140

Operator's Manual



Warning: Please read and thoroughly understand all instructions before operating. Failure to follow safety rules and other basic safety precautions may result in serious personal injury. Keep these instructions in a safe and easily accessible place so that they can be referred to when needed. Retain these instructions to assist in future servicing.

WARNING	1
SAFETY INTRODUCTION	2-3
TECHNICAL DETAILS	4
CONTROLS AND FEATURES	5
ASSEMBLY	6-9
OPERATION	10-13
CLEANING, STORING AND SERVICING	13
WARRANTY	13
TROUBLE SHOOTING	14

WARNING

A mobility scooter is not a toy. It is an electrically powered scooter and failure to follow safe operating procedures and safety warnings at all times could result in serious personal injury or death in addition to the injury or death of others.

The symbols below are used throughout this owner's manual and on the scooter to identify warnings and important information. It is very important for you to read them and understand them completely.



WARNING! Indicates a potentially hazardous condition/situation. Failure to follow designated procedures can cause either personal injury, component damage, or malfunction.



MANDATORY! These actions should be performed as specified. Failure to perform mandatory actions can cause personal injury and/or equipment damage.



PROHIBITED! These actions are prohibited. These actions should not be performed at any time or in any circumstances. Performing a prohibited action can cause personal injury and/or equipment damage.



CALIFORNIA PROPOSITION 65 WARNING! This product may contain substances which are known to the state of California to cause cancer and birth defects or other reproductive harm. For more information, go to www.P65Warnings.ca.gov.

The scooter has been designed and engineered to be very safe during normal operation. As with all cordless products, certain safety precautions should be taken.

Driving a mobility scooter requires a combination of healthy traits and abilities, including but not limited to: good vision; strength; coordination; balance and concentration. If you have these traits and abilities, you are on the right track.

UNDERSTAND THESE SAFETY PRECAUTIONS BEFORE OPERATING MACHINE. FAILURE TO PROPERLY FOLLOW THESE PRECAUTIONS MAY LEAD TO A FIRE, EXPLOSION, OR ELECTRICAL SHOCK HAZARD.

INTENDED USE

The intended use of this Battery Powered Scooter is to provide mobility to persons with full use of their upper and lower extremities and who are able to support themselves in an upright position. This product is primarily for indoor use and the outdoor capabilities are limited to hard, flat, and even surfaces such as concrete, black top, and other similar surfaces. While we understand that the scooter's outdoor capabilities are limited, when driving near uneven obstacles, follow the safety guidelines outlined within the safety section of this manual.

* Non-Medical Device

This product is not a medical device and is not intended to assist, treat, diagnose or alleviate any medical condition or disability.

SAFETY INTRODUCTION

1. SAFETY INSTRUCTIONS. The below instructions and tips will help you to operate your Scooter safely.

PLEASE NOTE - The Scooter is designed to be used by one person at a time and is not recommended for any person younger than 16 years old.

- Read this Manual and all safety and training instructions and all warning labels before operating the Scooter.
- Do not carry passengers or exceed the maximum weight capacity.
- Do not mount or dismount the Scooter unless it is resting at a complete stop, on a level surface, parking brake engaged and is turned off.
- Comply with all local laws and regulations while operating the Scooter.
- Check that all folding levers and clamps are securely locked before use.
- Always slow down before changing directions and turning.
- Always use both hands on the handlebar.
- Always keep your feet on the foot rests when driving the Scooter.
- Always approach small obstacles straight on and at slow speeds. Do not attempt to drive over curbs, potholes, puddles or any other road hazards. Use common sense when operating the Scooter. Reckless driving can result in an accident!

2. SAFE OPERATING CONDITIONS:

- Do not operate this scooter in traffic.
- Be very careful with inclines. Read below sections for details
- Do not operate this scooter on surfaces that are wet, frozen, oily, or unpaved.
- Never carry passengers or objects that can hinder your ability to safely operate this scooter.
- Never use headphones or a cell phone to talk or text while riding.
- Do not exceed the maximum weight capacity.

3. PREGNANT OPERATORS: Pregnant women should not operate this scooter.

4. DRIVING IMPAIRED: Never use alcohol or drugs before or while operating this scooter. The use of such hinders your ability to safely operate the scooter.

5. STUNTS: This scooter is not designed for stunts or tricks and should not be used as such. High speeds, jumps, wheelies, and other trick maneuvers are dangerous and can result in loss of control, accidents, and injury/death to self or others.

6. INCLINES: Never operate this scooter on steep inclines (inclines that have slopes steeper than a standard handicap ramp). Always climb and descend inclines straight on and at slow speeds. When climbing inclines, you may need to allow more power to the motor and maintain your speed depending on the steepness of the hill and rider weight so that the scooter does not lose momentum.

If the scooter loses momentum and comes to a stop on an uphill, quickly apply the hand brake and put both feet on the ground. Get off the Scooter and walk the product either up or down the incline.

The scooter has a short wheel base and a high center of gravity. It may become unsteady at excessive speeds. Avoid excessive speeds that can be associated with downhill rides. When going downhill, always actuate the brakes to control the speed. The scooter has a mechanical brake. Always check the brake BEFORE beginning to go downhill.

Never go downhill without brake being enabled.

WARNING

Failure to control your speed or attempting a sharp turn when descending a hill can result in serious injury or death.

7. GUEST USE: Never permit a guest to use this scooter unless the guest has read the user manual and all the warnings. Never allow more than one person at a time to ride the scooter. Never exceed the maximum weight capacity.

WARNING

This product should not be used by persons unwilling or unable to take responsibility for their own actions.

8. INSURANCE: YOUR INSURANCE POLICIES MAY NOT PROVIDE COVERAGE FOR ACCIDENTS INVOLVING THE USE OF THIS SCOOTER. TO DETERMINE IF COVERAGE IS PROVIDED, CONTACT YOUR INSURANCE COMPANY OR AGENT BEFORE USING THE SCOOTER.

9. OPERATOR AGE: Do not allow anyone under the age of 16 to operate this scooter. This scooter is designed for operation by and the transport of only one person age 16 or older.

- 10. SURROUNDINGS:** Ride your scooter in a controlled environment away from vehicles, obstacles, and other hazards. Never operate the scooter near steps or swimming pools. Do not drive the scooter on grass, gravel, or any other textured or bumpy surface.
- 11. INTENDED USE:** This scooter is not designed or intended for stunt tricks, including but not limited to jumps, back wheel wheelies, front wheel wheelies, or operating while standing on the scooter. Always stay seated, keep both hands on the handlebar, both feet on the foot pedal and all three wheels touching the ground while operating the scooter.
- 12. SPEED:** The scooter's maximum speed gives the scooter the most torque or power for climbing inclines. For your safety, be careful to control your speed when descending hills or turning. The scooter has a short wheel base and can become unsteady at excessive downhill speeds or sharp turns. Do not use maximum speed while making turns.
- 13. VISIBILITY:** Do not ride your scooter at night or in conditions of poor visibility. Riding at dawn, dusk, or at times of poor visibility without a lighting system that meets state and local laws, and without approved reflectors, is illegal, dangerous, and can result in serious injury or death.
- 14. TEMPERATURE:** Do not use the scooter when the temperature is below 0°C (32°F).
- 15. WEATHER CONDITIONS:** Avoid riding in wet or icy conditions. Stop the scooter and walk it across rough or slippery road conditions.

 WARNING

Wet or icy weather impairs traction, braking, and visibility for riders and other vehicles and pedestrians sharing the roads. The risk of accident is dramatically increased in wet or icy conditions.

- 16. SURFACE CONDITIONS:** The scooter is intended for use on hard, flat, dry paved surfaces without loose debris such as sand, leaves, rocks or gravel. Wet, slick, bumps, uneven or rough surfaces may impair traction and contribute to possible accidents. Do not ride your scooter in mud, grass, gravel, sand, ice, or water. Watch out for potential obstacles that could catch your wheel or force you to swerve suddenly or lose control. Avoid sharp bumps, drainage grates and sudden surface changes. Stop the scooter and carefully walk it across rough or slippery road conditions.
- 17. WATER RESISTANCE:** Although some water resistance measures have been made, riding the scooter through standing water, rain, wet or muddy conditions runs the risk of severely damaging it. Do not immerse the scooter in water or directly spray the scooter when cleaning. When parked outside where rain is possible, cover the handlebar controls with water resistant materials to protect the electric controls.
- 18. SAFETY WHEN NOT RIDING:** When the scooter is not being used for riding, place it in a safe stable and secured environment, keep it away from fire, water and other hazards. When the scooter is in its upright vertical self standing mode, especially in moving public transportation or other crowded space, pay attention to its stability as accidental tipping-over could cause personal injury as well as damage to the scooter. Always hold the handlebar to prevent it from tipping over and falling to the ground. To save the battery life, SWITCH OFF the power, or REMOVE the battery from scooter, when reset.

TECHNICAL DETAILS

SKU#	GUT140	
Performance	Load capacity	330LBS (150kgs)
	Forward speed	4.6mph* (7.5km/h)
	Reverse speed	1.8mph (2.9km/h)
	Range per charge	5.5miles* (8.8km)
	Tuning Radius	43"
	Rated Slope	9° (15.8%)
Size & Weight	Unfolded dimension	41.7" x 24" x 37" (1060x610x940mm)
	Folded dimension	27.5"x24"x16.9" (700x610x430mm)
	Handlebar-to-Ground height range	32.2" ~ 36.2" (820-920mm)
	Seat-to-Ground height range	20.5" ~ 22.8" (520 ~ 580mm)
	Frame weight	32LBS (14.5kgs)
	Detachable battery weight	2.0LBS (0.9kgs)
	Seat weight	15LBS (6.8kgs)
	Product Weight	49Lbs (22.3kgs)
	Seat size	17.7" x 19" (450x480mm)
	Ground clearance	3.3" (85mm) at midframe
Tires	Size	8" solid
	Brake	Dual drum brake, manual
	Brake distance	< 39" (1.0m)
	Input voltage	48V
Motor	Type	Brushless hub motor
	Voltage	48V
Detachable Battery	Capacity	2.0Ah
	Type	Li-ion battery
	Continue working time per charge	Up to 1h45min
Charger	Input voltage	100-240V
	Charging time	1.5h

* Top speed and range per charge depends on rider weight, wind speed, temperature, riding style, riding surface, battery condition, and other factors. Actual top speed and range per charge may vary.

CONTROLS AND FEATURES

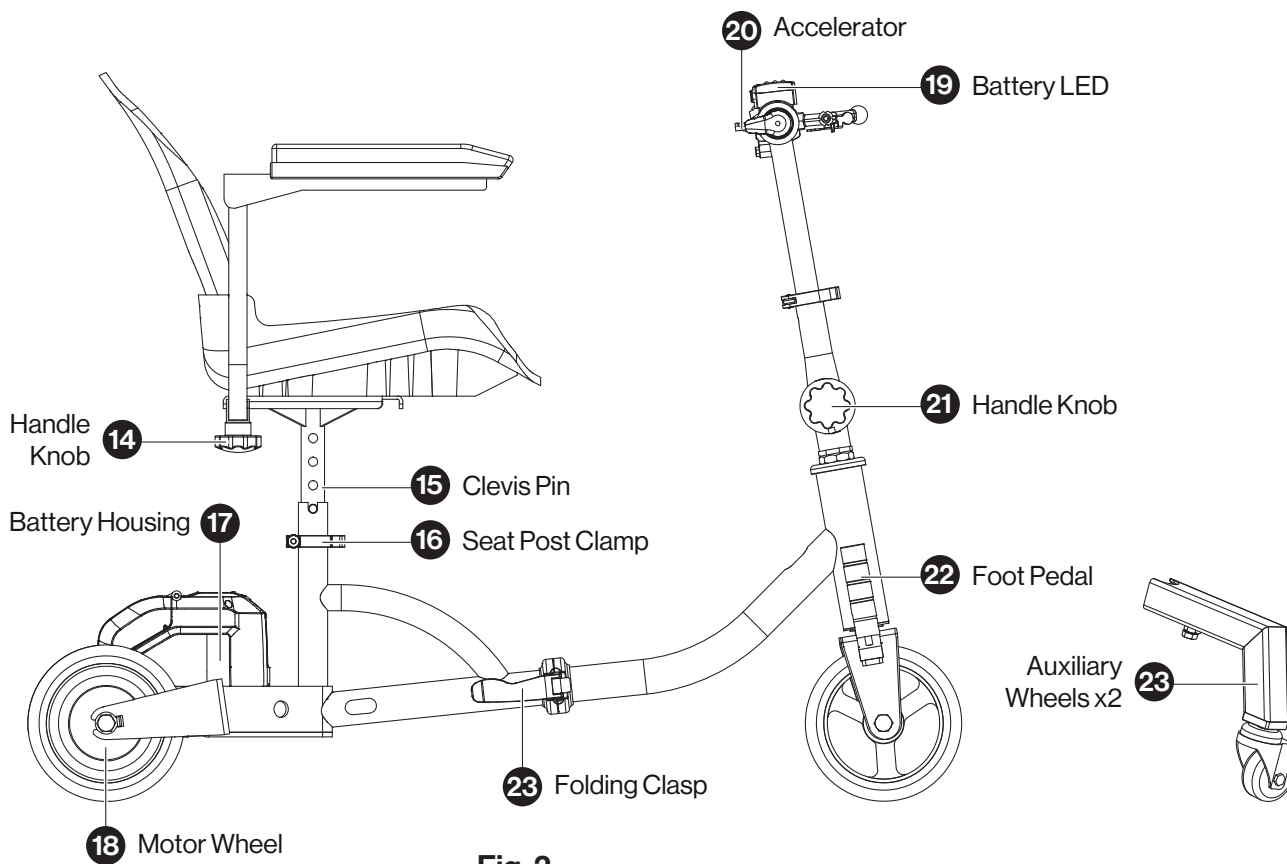
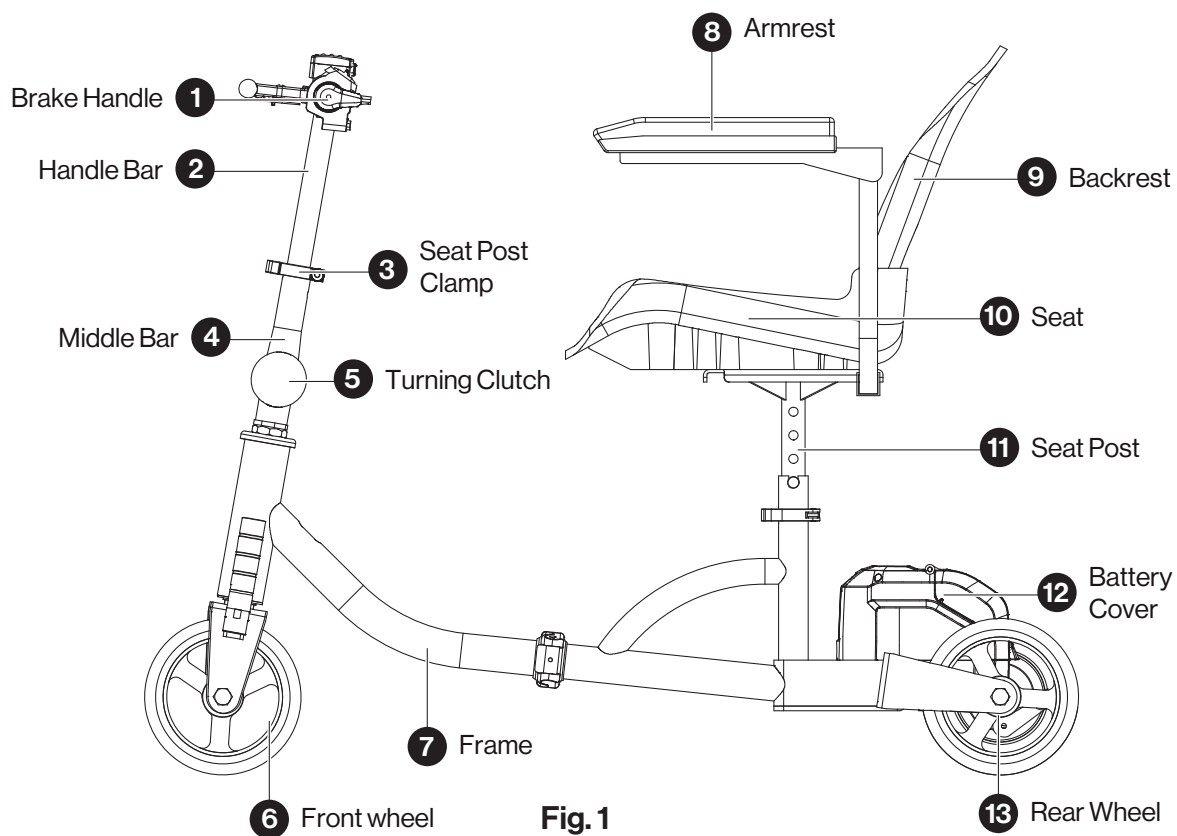

ASSEMBLY

For video instructions, please visit our website at www.greatcircleus.com. We encourage you to view the video instructions prior to unfolding/folding operation to avoid damage to your scooter.

1. Unfolding Scooter (See Fig. 3)

Take scooter out of box. Loosed belt between foot pedal and handle bar which fixed scooter when transportation. Slowly turn the front wheel to forward till the folding clasp closed. Be careful and make sure the wires moving smoothly wires inside frame tube, don't clamp wires.

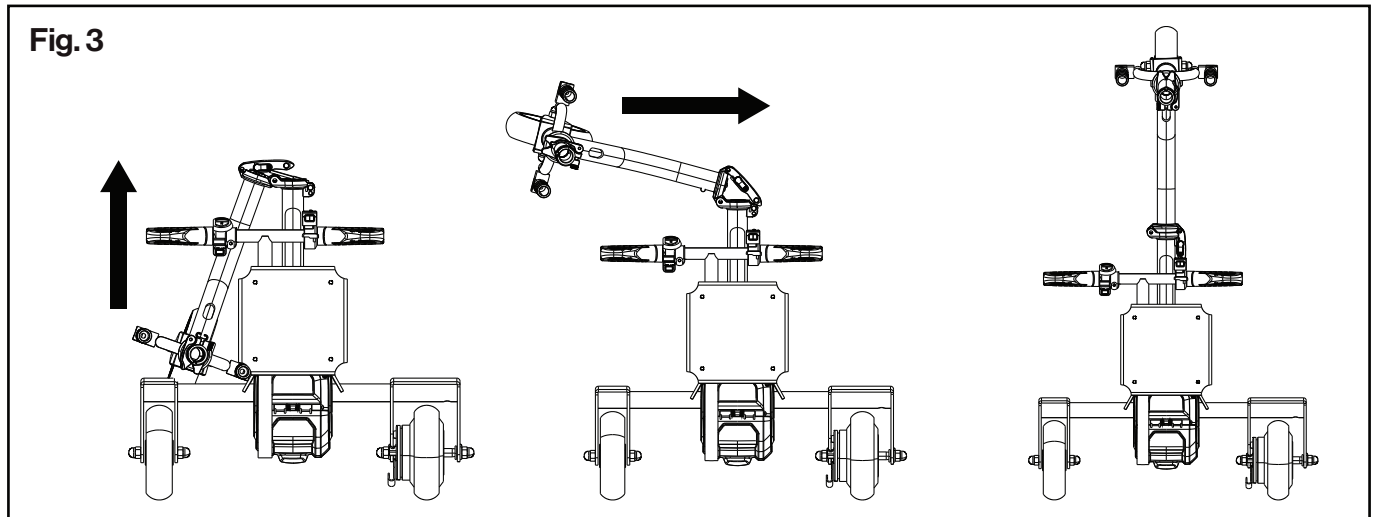

2. Assemble Handbar (See Fig. 4)

- 2.1 Insert handle bar to the frame.
- 2.2 Use a M6 bolt that go through the holes of handle bar and frame, and fix it with nut.
- 2.3 Tighten the nut at the clamp, until completely close the handle bar.

HANDLE-BAR ANGLE ADJUSTMENT

- 2.4. Loosen the hand knob.
- 2.5. Lift the handle-bar up to a proper angle for yourself.
- 2.6. Tighten the hand knob to fix the handle bar.

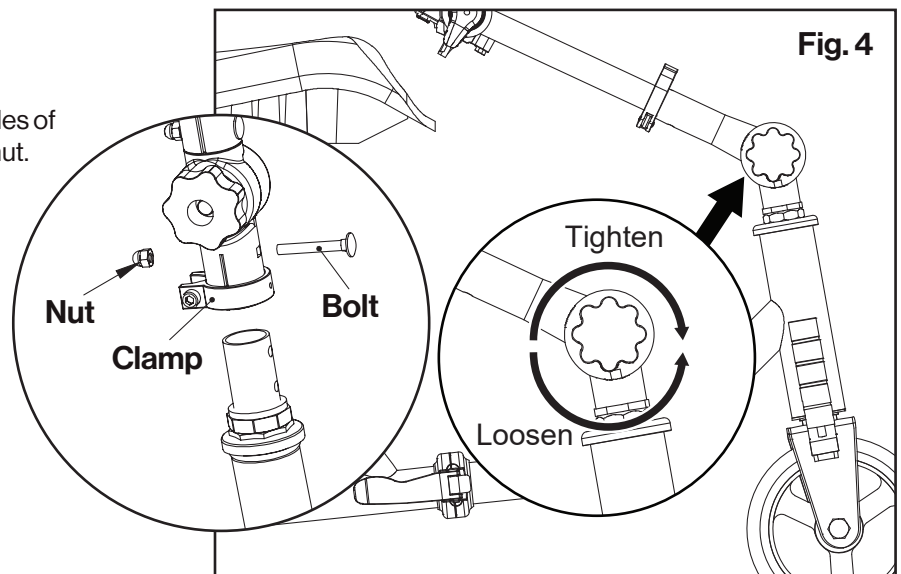

3. Assemble Seat (See Fig. 5)

Insert Clevis pin to hole of seat post which control the height of seat, insert seat post to frame, make pin fully inside notch, and then closed seat post clamp. Adjust the screw if necessary to make more tighten.

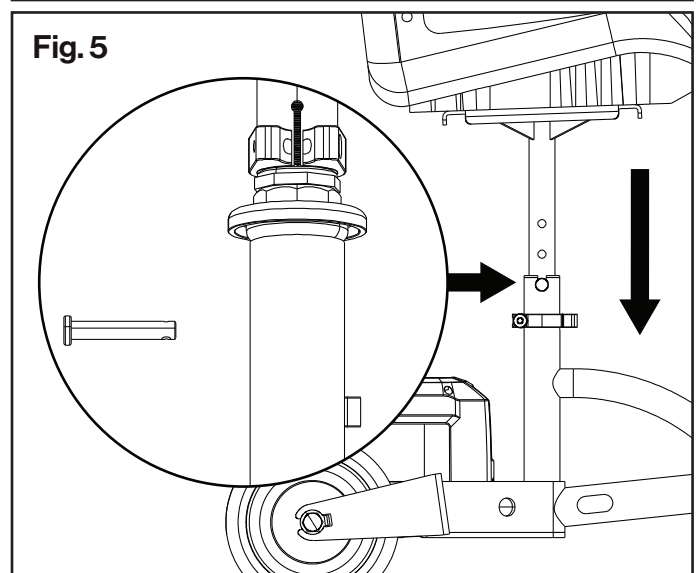

4. Assemble Armrest (See Fig. 6)

Insert armrest to the fixing tube of seat post, and screw it by handle knob.

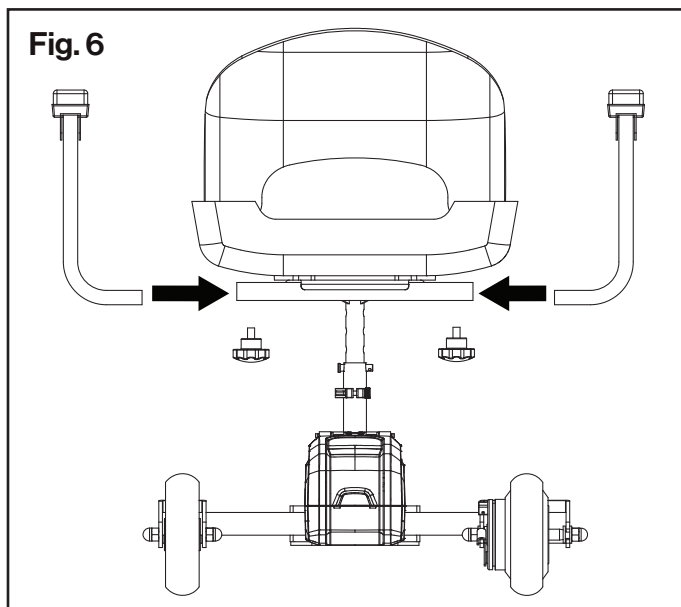

5. If necessary, turning the brake handle forward, and close the screw with Hex key. (See Fig. 7)

VERY IMPORTANT: Always make sure the components are fixed very well before drive.

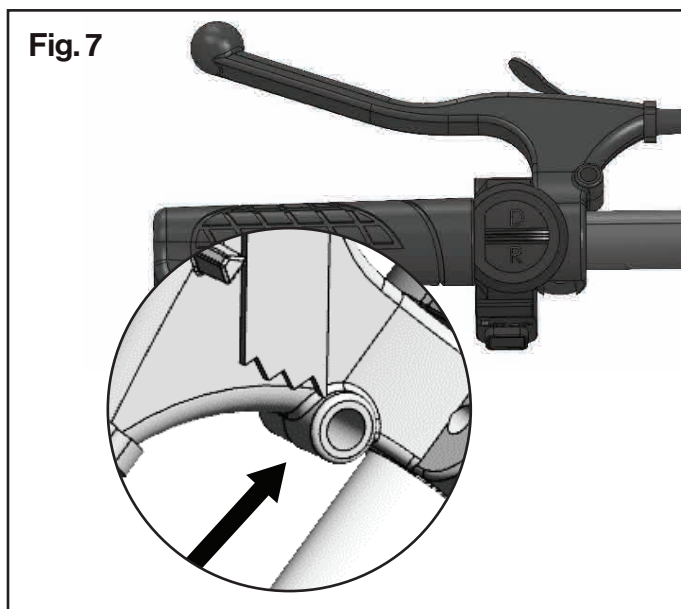

6. Assemble auxiliary wheels (See Fig.8)

1. Insert the auxiliary wheel into the foot pedal to the end.
2. Tighten the screws to fix it securely. It's better to use the wrench to fix.

The auxiliary wheel would reduce the risk of the tip over in some conditions.

You could assemble it according the real application conditions.

▲WARNING

Do not make turns at high speeds or on steep inclines. Your scooter may tip over.

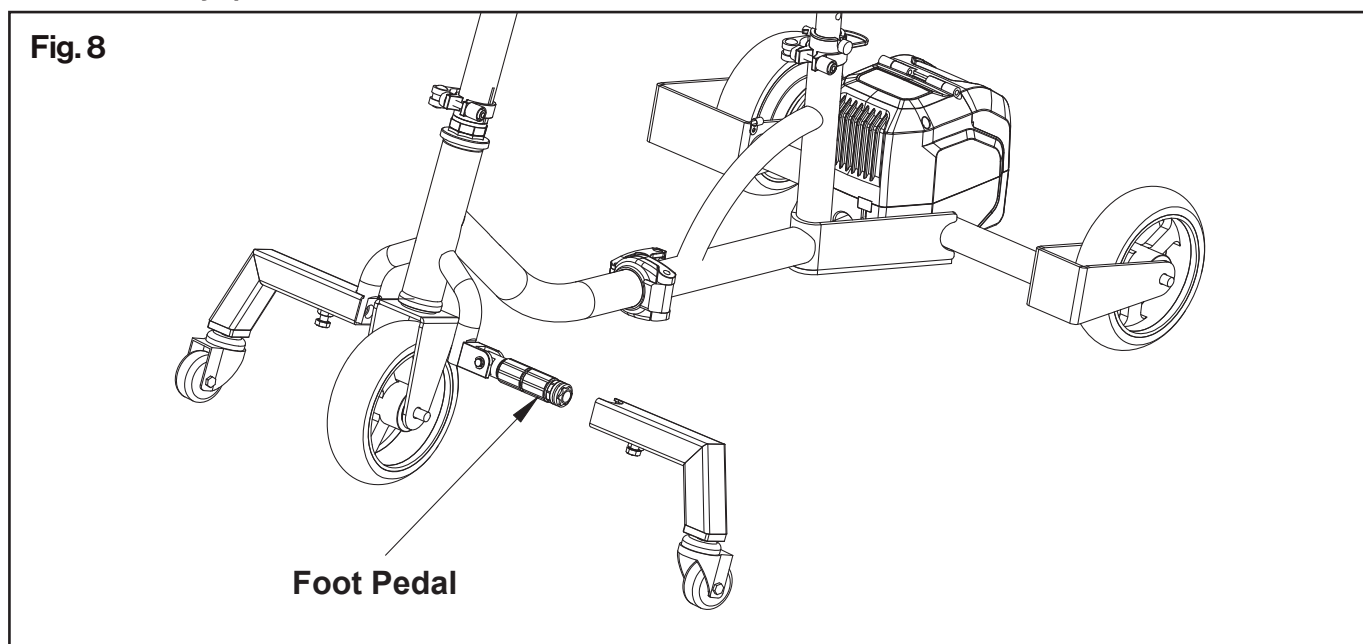

FOLDING SCOOTER (See Fig. 9)

1. Make sure power is off.
2. Release seat post clamp under seat, and remove seat. Close foot pedal.
3. Push the button in folding clasp (1), and open the clasp (2), slowly turn front wheel backward. Close it in back frame.
4. Release upper seat post clamp in handlebar, go down lowest position, and close seat post clamp. Loosen the hand knob, lay down the handle bar, and tighten the hand knob to fix handle bar.
5. The scooter can be kept in smallest size.

SEAT HEIGHT ADJUSTMENT

The seat can be repositioned to different heights.

1. Loosen the seat post clamp.
2. Remove seat and its attached seat post by twisting seat left/right, and remove from seat frame.
3. Remove clevis pin from the seat post.
4. Raise or lower the seat and its attached seat post to the desired seat height.
5. While holding the seat at the desired height, align the adjustment holes of the seat post with notch of seat frame.
6. Fully insert clevis pin.
7. Tighten the seat post clamp.

HANDLE-BAR HEIGHT ADJUSTMENT

The handle-bar can be repositioned to different heights.

1. Loosen the upper seat post clamp.
2. Move up/down handle-bar to desired height.
3. Hold the handle-bar at the desired height, tighten the seat post clamp. (See Fig. 10)

HANDLE-BAR ANGLE ADJUSTMENT

1. Loosen the hand knob.
2. Lift the handle-bar front or back to a proper angle for yourself.
3. Tighten the hand knob to fix the handle bar.

BASKET INSTALLATION

Your scooter has an optional basket. To install the basket, hooks across the handle-bar, and hold in middle of handle-bar. Then carefully rotate the hooks and rest the hooks on the handle-bar naturally. And close the Velcro band around the handle bar tube.

OVERVIEW SCOOTER

Power On/Off (See Fig. 11)

The red knob in left hand side is the power switch. Push on it, power is On. Push on again, power is off.

Forward/Reverse (See Fig. 12)

Control knob also in left hand side. Push upward, scooter driving direction is forward. Push downward, driving direction is reverse. It is normal that you engage the scooter after one second when switch between forward/reverse. This second is the protection of electrical system.

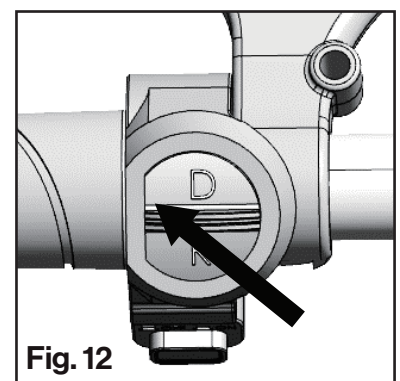
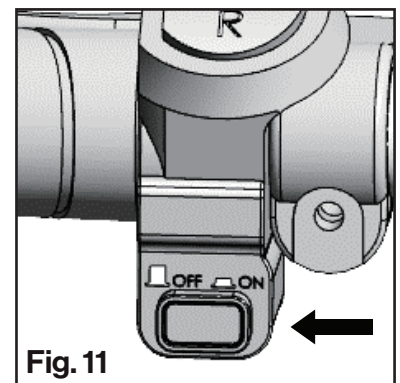
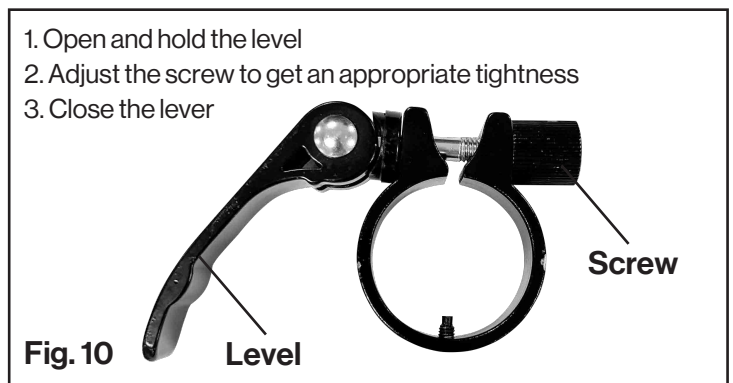
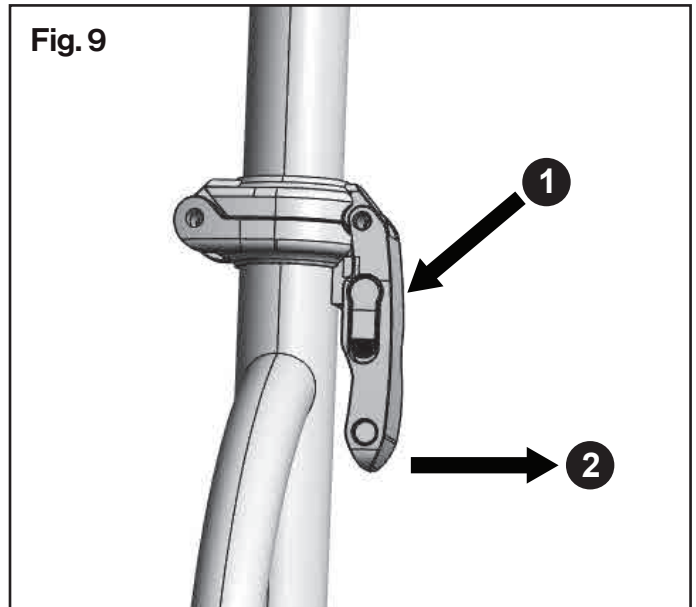

Brake (See Fig. 13)

The left brake handle is controlled mechanical brake which lock the drum brake in the right rear wheel. When actuated brake handle, it will stop scooter and cut power supply to the motor. Release brake handle and accelerator, power will connect motor again. Also, there is parking brake at front of handle. While actuated brake handle, press the parking brake, the right rear wheel is locked, and scooter is in parking situation.

In a safe, controlled environment, please familiarize yourself with the braking distance of the scooter at different speeds before operating near intersections, pedestrians and other obstacles.

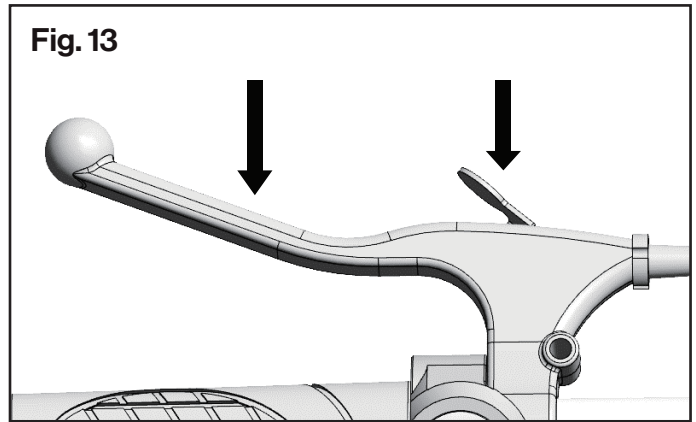

Accelerator (See Fig. 14)

The right thumb control is the accelerator. The further you press the accelerator down, the more energy you will release to the motor, the speed will be faster.

CAUTION – Do not make turns at high speeds or on steep inclines. Your scooter may tip over.

Battery LED display (See Fig. 15)

LED display on handle-bar can show battery capacity easily.

Push the button, 3 LEDs will show the left capacity of battery.

3 LEDs on, capacity is 100%-70%; 2 LEDs on, capacity is 70%-30%; 1 LED on, capacity is less than 30%, it's better to charge battery if necessary.

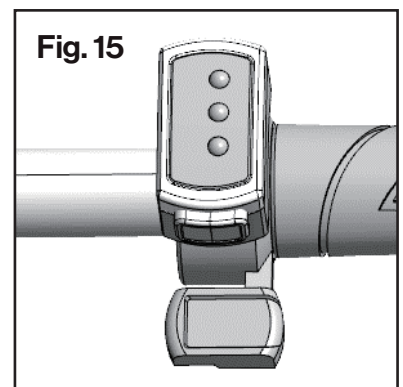
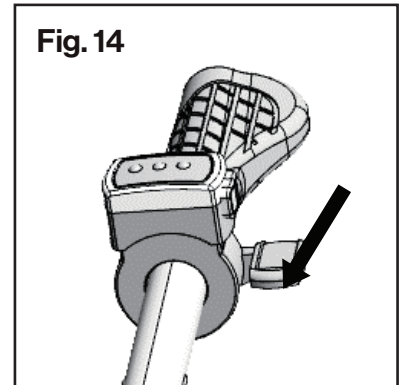

Battery Cover (See Fig. 16)

The battery cover prevent battery from impact. As the magnet slide at edge, it can close with housing.

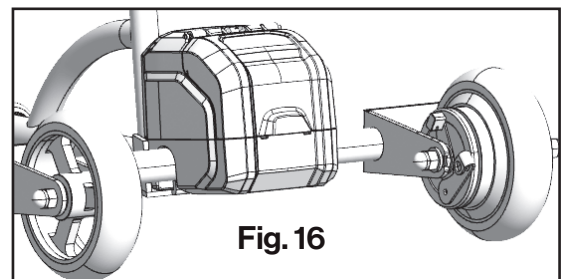

Drum Brake (See Fig. 17)

The brake is controlled by brake handle. While actuated brake handle, the rear wheels are not braked completely, you can adjust the screw to tighten. Or if brake handle is hard to actuate, loose the screw a little.

The scooter has two brakes, Fig.15 is shown the right brake. DO the same process for left brake that make brake tighten or loosen.

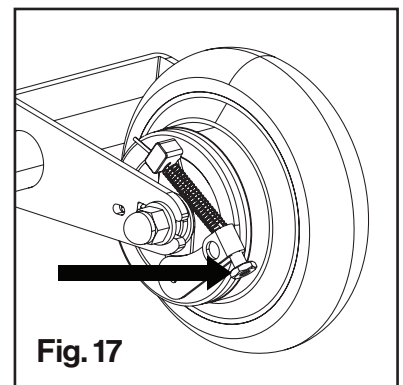

OPERATION

Just like learning to drive a car or ride a bicycle, operating any personal transportation device inherently includes risk and takes practice. Therefore, use caution as you practice operating the scooter in various situations. Keep the speed at a reduced level until you're comfortable controlling the scooter. The below instructions and practice steps will teach you to maneuver through doorways, on and off lifts, and up and down ramps. When preparing for your first ride, select an area that is flat, spacious, and away from traffic and other obstacles. Bring a friend along to help you follow the instructions while you practice. Start driving with the lowest speed.

Please refer to the Overview section of this Manual for instructions.

PRE-RIDE SAFETY CHECK

Get to know the feel of your scooter and its capabilities. We recommend that you perform a safety check before each use to make sure your scooter operates smoothly and safely.

Perform the following inspections prior to using your scooter:

- Check the condition of the tires. Make sure they are not damaged or excessively worn.
- Check the folding clasp. Make sure it's locked properly.
- Check all electrical connections. Make sure they are tight and not corroded.
- Check handle-bar and seat connections. Make sure they are secured properly.
- Check the brakes to ensure they operate properly.
- Check the battery LED display to ensure the battery is fully charged.
- Ensure the parking brake is engaged before sitting on the scooter.

BEFORE GETTING ONTO YOUR SCOOTER

- Have you fully charged the battery?
- Ensure the folding clasp is in the locked position.
- Ensure the parking brake is engaged.
- Ensure the power switch is in the "OFF" position.
- Ensure the air temperature is between 32°F/0°C to 120°F/49°C.

GETTING ONTO YOUR SCOOTER

1. Stand at the side of your scooter.

WARNING

Never attempt to get onto or off your scooter with the scooter "ON". Ensure parking brake is engaged prior to sitting on the scooter.

2. Make certain that the seat is secured into position.
3. Position yourself comfortably and securely in the seat.
4. Make certain your feet are safely on the foot pedal.

OPERATING SCOOTER

The following can adversely affect steering and stability while operating your Scooter:

- Holding onto or attaching a leash to walk your pet.
- Carrying passengers (including pets).
- Hanging any article from the handle-bar.
- Towing or being pushed by another motorized vehicle.

WARNING

Keep both hands on the handle-bar and your feet on the foot pedal at all times while operating your Scooter. This driving position gives you the most control over your vehicle.

1. Push power button on.
2. Release parking brake lever
3. Pull the appropriate side of the handle bar grips. Right if you want to go right, left if you want to go left.
4. Always start in the lower speed. Lightly press accelerator, make scooter move forward slowly, to be customized to speed of scooter before use maximum speed.
5. To go straight, move to the center position.
6. To go left, turn handle-bar left. To go right, turn handle-bar right.
7. To stop, release the accelerator and engage the brake handle.

GETTING OFF OF YOUR SCOOTER

1. Bring your Scooter to a complete stop.

⚠️WARNING

Never attempt to get onto or off of your scooter with it still on. This will prevent the Scooter from moving if accidental press accelerator.

2. Press power button to "OFF".
3. Set the parking brake by engaging the handbrake lever and then engaging the parking brake lever.
4. Carefully and safely get out of the seat and stand to the side of your Scooter.

URNS

It is essential to slow down to a reasonably slow speed before initiating a turn. Use extreme caution when turning on slanted or uneven surfaces. Occasionally you may find yourself negotiating a curve or corner too fast and the inner rear wheel starts to lift off the ground. If this happens, immediately reduce your speed, lessen the steering angle and shift your upper body toward the wheel that is lifting off the ground.

INCLINES AND DECLINES

Incline conditions require special attention to avoid mishaps. The scooter is not designed to go up steep or long inclines. Be aware that not all ramps are constructed according to government standards. The government standard for wheelchair ramps is 1 inch (2.5cm) rise per foot (30cm) (5° incline).

⚠️WARNING

An incline that is too steep or long can create a dangerous situation. The scooter can lose momentum causing it to slide backwards down the incline or tip over backwards. It is not recommended to drive the scooter on any ramp, incline or hill that doesn't meet government wheelchair ramp standards.

Tips for driving the scooter on inclines and declines:

- Never travel up or down on an incline that is potentially hazardous such as one that is wet, icy, slippery, has loose gravel, etc.
- Always start an incline at the base of the hill and not at an angle.
- Shift your upper body towards the handle-bar to shift weight to the front wheel.
- Slowly press accelerator, to move the scooter forward.
- Never stop the scooter on an incline. Do not zigzag, but travel in a straight line to the top.
- If the scooter loses momentum, quickly apply the hand brake and put both feet on the ground. Get off the scooter and control scooter either up or down the incline.
- Go very slowly while driving down a ramp. Do not go down the ramp or hill at a side angle. Try to avoid turns while descending. Keep your hand on the brake handle and slowly apply pressure if the scooter picks up too much speed.

CURBS

The scooter should not be driven over any curb. Apply the brake, turn off the scooter and get off the scooter. Lift or walk the scooter around the curb prior to getting back on.

⚠️WARNING

Attempting to drive over a curb can cause the product to tip over backwards resulting in possible injury and will cause damage to the scooter. Also use caution when driving on sidewalks near curbs to avoid one wheel falling off the curb. This will cause the scooter to tip over and can result in serious injury or death.

SPEEDBUMPS AND UNEVEN SURFACES

Generally, the scooter can handle slightly uneven surfaces. You should approach each at a reduced speed and in a direct frontal position.

Please keep in mind that the small wheels cannot roll over objects higher than 2 inches (5cm) and you may fall if you attempt to do so.

⚠️WARNING

Attempting to drive over speed bumps or uneven surfaces can cause the product to tip over backwards and can result in serious injury or death.

POTHoles AND PUDDLES

Avoid all potholes and deep puddles.



Attempting to drive over potholes or deep puddles can cause the product to tip over backwards and can result in serious injury or death.

INDOOR USE

Similar to an electric wheelchair, you are generally permitted to use the scooter inside of buildings, airports, shopping malls, stores, theaters, etc. Doors can be a challenge when using the scooter. Approach each door slowly making sure that the rear wheels will make it through the door opening. The scooter cannot go into door narrower than 24 inches (62cm).

OUTDOOR USE

The scooter should only be ridden on smooth hard and flat surfaces. It is not designed for off-road conditions. Do not use the scooter in rain or snow nor drive it through puddles of water.

Slightly uneven surfaces should be approached at a reduced speed and in a direct frontal position and may require lifting or walking the scooter around the surface.

Please keep in mind that the small wheels cannot roll over objects higher than 2 inches (5cm) and you may fall if you attempt to do so. You should not tow anything behind the scooter.

BATTERY AND CHARGER

BATTERY

Your scooter requires one 48 Volt Lithium-Ion battery that is easy detachable.

1. Fully charge the battery before first time operation or after a long period of non-usage.
2. For safety reasons, the battery is about 50% charged when shipped from the factory.
3. Before remove battery, make sure power is Off, and scooter stand at flat surface. Open battery cover, press the grey button of battery, and then you can remove out battery.
4. Insert charger pin to the hole at middle of battery. In charging, the LED light on the charger is solid red. When fully charged, LED turns solid green.
5. Always charge the battery in a clean, dry location, free of debris.
6. Charge the battery frequently. The battery can be recharged at any time. Do not think that you need to fully deplete the battery before recharging it. In fact, frequent partial discharge/charge cycles will prolong the battery life vs. fully discharge/charge cycles.
7. Fully charge the battery before storing the scooter for extended periods.
8. When not in use for long time, remove battery from scooter, and periodically recharge the battery once every 8 months.
9. Battery damage due to water, collision, improper storage and other non-normal factors is not covered by the limited manufacturer warranty.

BATTERY LEVEL INDICATOR

LED on battery also shows battery capacity. It's a little different from LED indicator at handle-bar.

1. One LED (one red): 0-30% battery capacity;
2. Two LEDs (one red, one green): 30%-60% battery capacity;
3. Three LEDs (one red, two green): 60%-80% battery capacity;
4. Four LEDs (one red, three green): 80%-100% battery capacity.

Soft Riding Condition. When the battery is nearly depleted, a "soft" riding condition can occur.

A "soft" riding condition means the scooter can move forward at lower speed compared with fully charged battery. When this happens, turn the scooter back on and drive the scooter under low speed until you can recharge the battery, or exchange a new battery.

CHARGER

1. The battery is charging when the LED light on the charger is red. When the battery is 100% charged, the light on the charger will turn solid green.
2. The provided charger has a built-in overcharge protection to prevent the battery from being overcharged.
3. Charging time is approximately 1.5 hours for a fully discharged battery.
4. Regularly inspect the charger for damage to the cord, plug, enclosure and other parts. In the event of such damage, the charger must not be used until it has been repaired or replaced.
5. Unplug the charger from the wall outlet when not in use. **As a safety mechanism, when the charger stops charging because the battery is full, the charger must be reset by unplugging it from the wall outlet before it will resume charging.**
6. **Use only the charger supplied with this scooter or a recommended replacement specified by GreatCircle.**

⚠️ WARNING

Failure to confirm compatibility, properly install, operate and maintain any charger, component or accessory can result in serious injury or death.

INSTRUCTIONS FOR CHARGING

1. Turn the scooter power off. Open the battery cover and get out battery.
2. Securely plug the charger into the charge port, and plug to power supply.
3. Insert charger pin to the hole at middle of battery.
4. A solid red light on the charger indicates the battery is charging. A solid green light indicates the battery is fully charged.
5. Remove the plug from the power supply, then remove the battery from charger.
6. You will not damage the battery by riding the scooter until the battery is fully discharged and the scooter motor shuts down.

BATTERY USE AND CARE WARNINGS

⚠️ WARNING

1. Battery must be fully charged before first use.
2. Plug the charger into a 110-240 AC outlet, a red light should appear on the charger. Charge the battery until the light on the charger turns solid green.
3. Always charge the battery at room temperature. If the battery is used in a cold environment, allow it to warm up for at least an hour before charging. Cold batteries will not be charged completely and battery components may be damaged.
4. Only charge battery in well ventilated area away from flammable materials such as cloth or carpeting.
5. To disconnect charger, remove the plug from outlet, then disconnect the charger from the battery.
6. **DO NOT** leave the charger being connected to the battery for more than 24 hours.
7. The battery status indicator is mounted on the top of the battery to allow you to observe the level of the battery power while in use. To check the charge level, simply press the indicator button. The lights on the status indicator show the charge level of the battery.
8. If battery becomes warm or hot during charging procedure, disconnect it from charger. Allow battery to return to room temperature, and attempt to charge again. If this persists a second time, disconnect battery from charger and contact customer service.
9. Battery Maintenance Responsibility: **Fully charge and discharge the battery at least once every 8 months** to maintain battery's health.
10. **Store the battery on a full charge.**
11. When battery pack is not in use, keep it away from other metal objects like paper clips, coins, keys, nails, screws, or other small metal objects that can make a connection from one terminal to another. Shorting the battery terminals together may cause burns or fire.
12. To save the battery life, **SWITCH OFF** the power of scooter, or **REMOVE** the battery from scooter, when reset.

CLEANING, STORING AND SERVICING

1. **KEEP YOUR SCOOTER DRY:** Do not ride your scooter in wet conditions unless unavoidable. Dry off your scooter immediately.
2. **KEEP YOUR SCOOTER CLEAN:** Remove dust and dirt from your scooter with a wrung-out, damp rag. Dry immediately. Never use solvents. Do not spray your scooter down with water or submerge it.
3. **STORAGE:** Battery performance is susceptible to temperature. Do not store your scooter in direct sunlight or in a high temperature environment like inside of your car. Store your scooter indoors, out of the elements. Room temperature is ideal for storage. Avoid storing the scooter in wet environments. Recharge the battery in full after it has been completely discharged and before storing the scooter for longer periods. Even in storage, please monitor the battery level and recharge the battery fully at least once every 8 months.
4. **SERVICE:** Should your scooter require service, please contact customer service through our website (www.greatcircle-us.com) or support line: 1-866-493-0524. Your satisfaction is our greatest priority!

WARRANTY

Twelve (12) months for workmanship of the product, except for wearing parts. Warranty period starts from the product purchase date. Warranty covers material quality and workmanship only. Warranty does not cover product for issues caused by improper usage or any operation not in accordance with the specifications of this manual. Any modification or tampering with the product in any way voids the warranty.

TROUBLE SHOOTING

Problem	Possible Cause	Solution
The scooter does not operate.	The scooter is not turned on.	Turn on scooter by pressing power button.
	The battery is not charged.	Charge Battery.
	The hand brake and parking brake are inadvertently engaged.	Make sure hand brake and parking brake are not engaged.
	The battery is not locked and secured.	Secure battery by locking it in the housing.
	Main circuit was broken.	Contact customer service at our website (www.greatcircleus.com) or support line: 1-866-493-0524
The Scooter Operates Intermittently.	The battery capacity is low and cause soft riding condition.	Recharge Battery.
	The battery is not locked and secured into its base.	Secure battery by locking it in the housing.
Short ride time or runs slow.	Rider weight.	Do not exceed maximum weight limit.
	Carry dolly or heavy luggage.	Do not carry any dolly and luggage.
	Riding conditions.	Use only on flat, dry surfaces. Avoid inclines and areas with debris on surface.
	Battery not fully charged.	Charge battery until full.
	Old/Damaged Battery.	Replace Battery.
	Main circuit was not connecting securely.	Contact customer service at our website (www.greatcircleus.com) or support line: 1-866-493-0524
Scooter is not stopped after actuate brake handle, or, it is hard to actuate brake handle.	Drum brake is too loosed, or too tighten.	Adjust the screw at drum brake at both sides.



Thank you for your most recent purchase.

superhandyus.com



Great Circle USA
Support Line: 1-866-493-0524
help@greatcircleus.com
www.superhandyus.com



Follow us on social media
@SuperHandy