

HEVX[®]

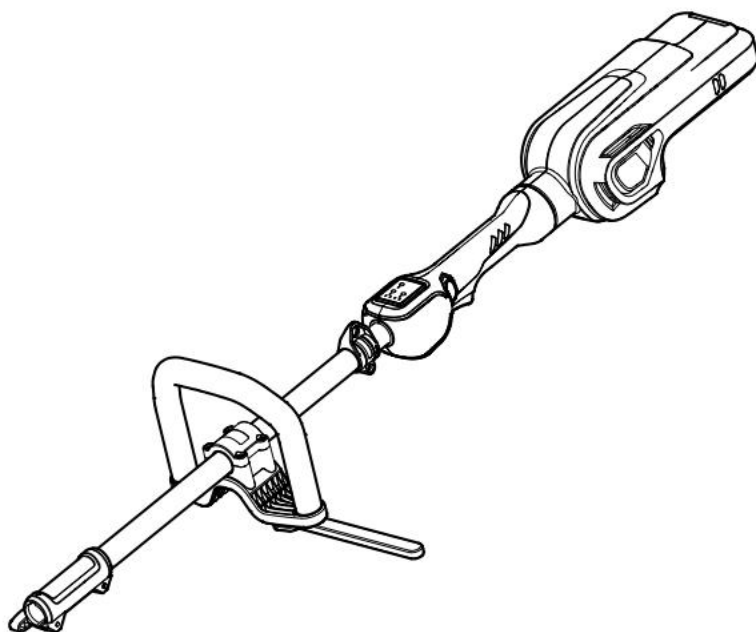

ORIGINAL INSTRUCTION
**40-VOLT LITHIUM-ION
CORDLESS POWER HEAD**
MODEL NUMBER A40DG65B01

WARNING: To reduce the risk of injury, the user must read and understand the Operator's Manual before using this product. Save these instructions for future reference.

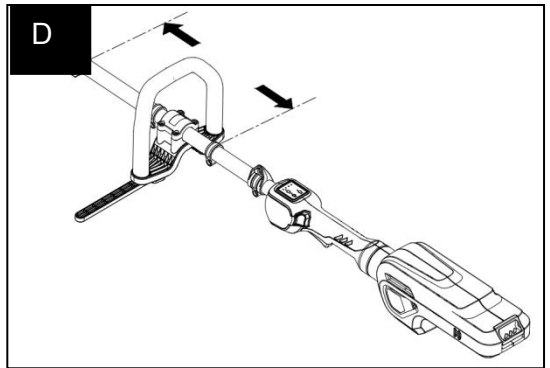
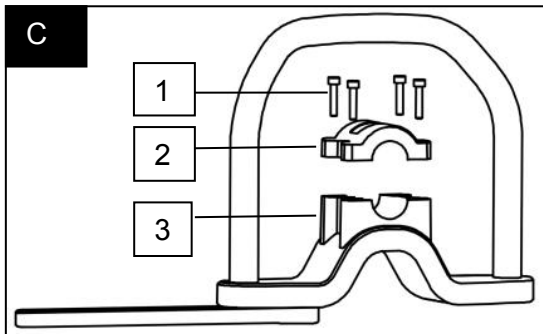
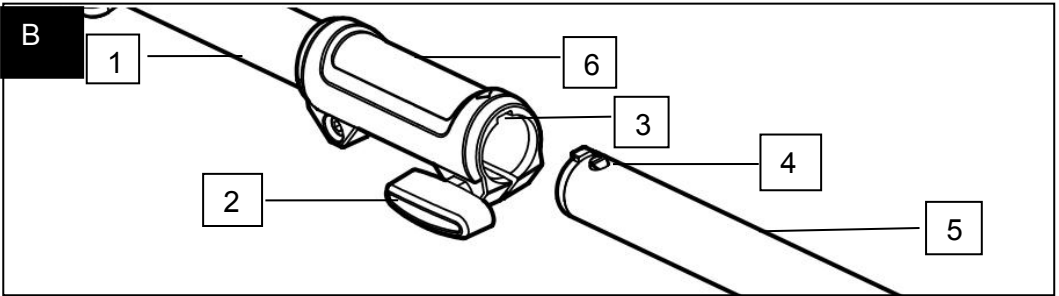
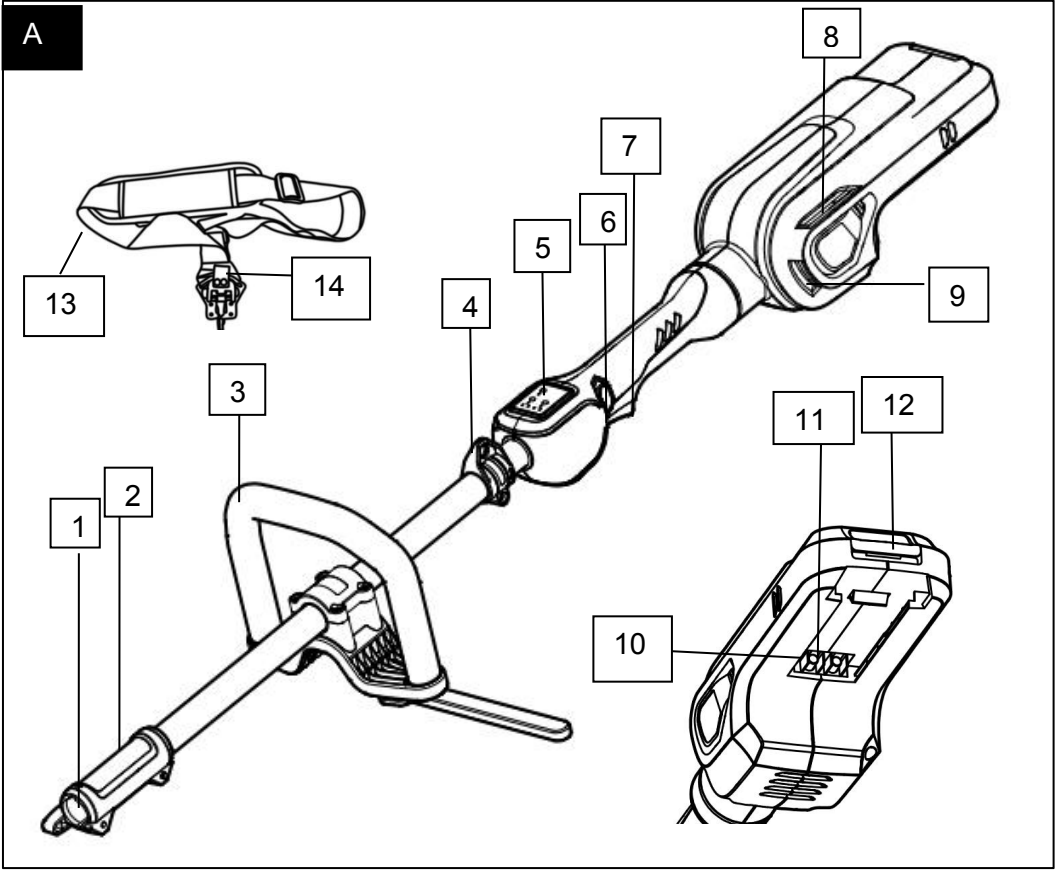

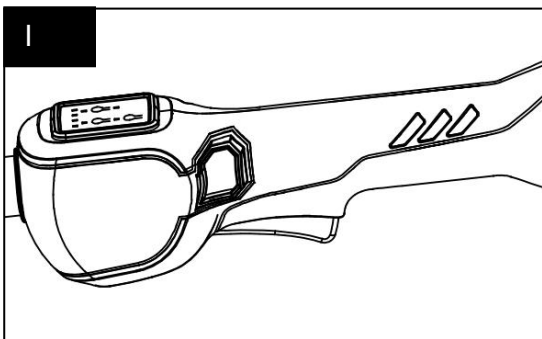
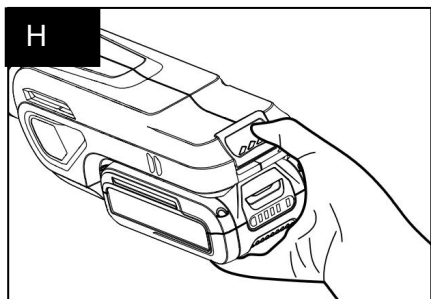
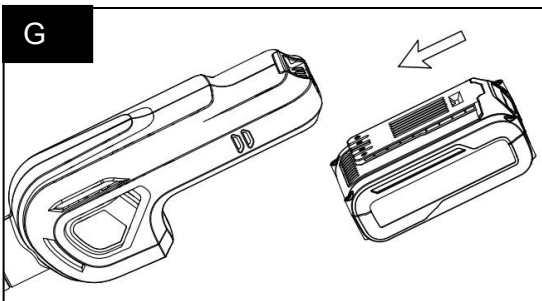
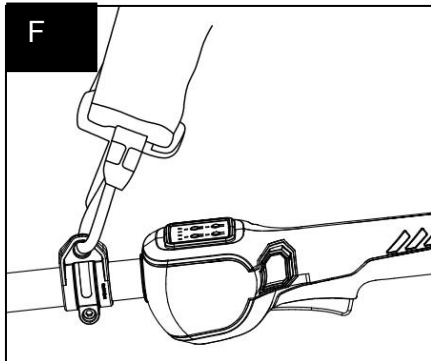
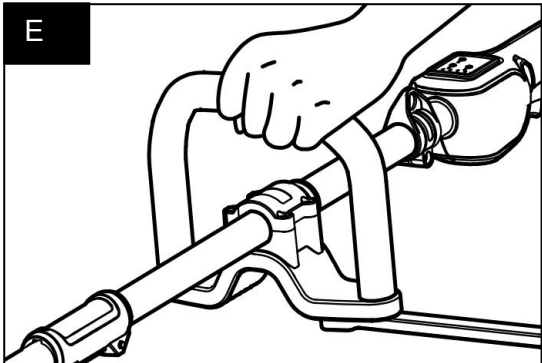

GENERAL POWER TOOL SAFETY WARNINGS

WARNING Read all safety warnings, instructions, illustrations and specifications provided with this power tool. *Failure to follow all instructions listed below may result in electric shock, fire and/or serious injury.*

Save all warnings and instructions for future reference.

The term "power tool" in the warnings refers to your mains-operated (corded) power tool or battery-operated (cordless) power tool.

1) Work area safety

- a) **Keep work area clean and well lit.** *Cluttered or dark areas invite accidents.*
- b) **Do not operate power tools in explosive atmospheres, such as in the presence of flammable liquids, gases or dust.** *Power tools create sparks which may ignite the dust or fumes.*
- c) **Keep children and bystanders away while operating a power tool.** *Distractions can cause you to lose control.*

2) Electrical safety

- a) **Power tool plugs must match the outlet. Never modify the plug in any way. Do not use any adapter plugs with earthed (grounded) power tools.** *Unmodified plugs and matching outlets will reduce risk of electric shock.*
- b) **Avoid body contact with earthed or grounded surfaces, such as pipes, radiators, ranges and refrigerators.** *There is an increased risk of electric shock if your body is earthed or grounded.*
- c) **Do not expose power tools to rain or wet conditions.** *Water entering a power tool will increase the risk of electric shock.*
- d) **Do not abuse the cord. Never use the cord for carrying, pulling or unplugging the power tool. Keep cord away from heat, oil, sharp edges or moving parts.** *Damaged or entangled cords increase the risk of electric shock.*
- e) **When operating a power tool outdoors, use an extension cord suitable for outdoor use.** *Use of a cord suitable for outdoor use reduces the risk of electric shock.*
- f) **If operating a power tool in a damp location is unavoidable, use a residual current device (RCD) protected supply.** *Use of an RCD reduces the risk of electric shock.*

3) Personal safety

a) **Stay alert, watch what you are doing and use common sense when operating a power tool. Do not use a power tool while you are tired or under the influence of drugs, alcohol or medication.** *A moment of inattention while operating power tools may result in serious personal injury.*

b) **Use personal protective equipment. Always wear eye protection.** *Protective equipment such as a dust mask, non-skid safety shoes, hard hat or hearing protection used for appropriate conditions will reduce personal injuries.*

c) **Prevent unintentional starting. Ensure the switch is in the off-position before connecting to power source and/or battery pack, picking up or carrying the tool.** *Carrying power tools with your finger on the switch or energising power tools that have the switch on invites accidents.*

d) **Remove any adjusting key or wrench before turning the power tool on.** *A wrench or a key left attached to a rotating part of the power tool may result in personal injury.*

e) **Do not overreach. Keep proper footing and balance at all times.** *This enables better control of the power tool in unexpected situations.*

f) **Dress properly. Do not wear loose clothing or jewellery. Keep your hair and clothing away from moving parts.** *Loose clothes, jewellery or long hair can be caught in moving parts.*

g) **If devices are provided for the connection of dust extraction and collection facilities, ensure these are connected and properly used.** *Use of dust collection can reduce dust-related hazards.*

h) **Do not let familiarity gained from frequent use of tools allow you to become complacent and ignore tool safety principles.** *A careless action can cause severe injury within a fraction of a second.*

4) Power tool use and care

a) **Do not force the power tool. Use the correct power tool for your application.** *The correct power tool will do the job better and safer at the rate for which it was designed.*

b) **Do not use the power tool if the switch does not turn it on and off.** *Any power tool that cannot be controlled with the switch is dangerous and must be repaired.*

c) **Disconnect the plug from the power source and/or remove the battery pack, if detachable, from the power tool before making any adjustments, changing**

accessories, or storing power tools. *Such preventive safety measures reduce the risk of starting the power tool accidentally.*

d) Store idle power tools out of the reach of children and do not allow persons unfamiliar with the power tool or these instructions to operate the power tool. *Power tools are dangerous in the hands of untrained users.*

e) Maintain power tools and accessories. Check for misalignment or binding of moving parts, breakage of parts and any other condition that may affect the power tool's operation. If damaged, have the power tool repaired before use. *Many accidents are caused by poorly maintained power tools.*

f) Keep cutting tools sharp and clean. *Properly maintained cutting tools with sharp cutting edges are less likely to bind and are easier to control.*

g) Use the power tool, accessories and tool bits etc. in accordance with these instructions, taking into account the working conditions and the work to be performed. *Use of the power tool for operations different from those intended could result in a hazardous situation.*

h) Keep handles and grasping surfaces dry, clean and free from oil and grease. *Slippery handles and grasping surfaces do not allow for safe handling and control of the tool in unexpected situations.*

5) Battery tool use and care

a) Recharge only with the charger specified by the manufacturer. *A charger that is suitable for one type of battery pack may create a risk of fire when used with another battery pack.*

b) Use power tools only with specifically designated battery packs. *Use of any other battery packs may create a risk of injury and fire.*

c) When battery pack is not in use, keep it away from other metal objects, like paper clips, coins, keys, nails, screws or other small metal objects, that can make a connection from one terminal to another. *Shorting the battery terminals together may cause burns or a fire.*

d) Under abusive conditions, liquid may be ejected from the battery; avoid contact. If contact accidentally occurs, flush with water. If liquid contacts eyes, additionally seek medical help. *Liquid ejected from the battery may cause irritation or burns.*

e) Do not use a battery pack or tool that is damaged or modified. *Damaged or modified batteries may exhibit unpredictable behaviour resulting in fire, explosion or*

risk of injury.

f) **Do not expose a battery pack or tool to fire or excessive temperature.** *Exposure to fire or temperature above 130 °C may cause explosion.*

g) **Follow all charging instructions and do not charge the battery pack or tool outside the temperature range specified in the instructions.** *Charging improperly or at temperatures outside the specified range may damage the battery and increase the risk of fire.*

6) Service

a) **Have your power tool serviced by a qualified repair person using only identical replacement parts.** *This will ensure that the safety of the power tool is maintained.*

b) **Never service damaged battery packs.** *Service of battery packs should only be performed by the manufacturer or authorized service providers.*

Additional safety instructions for extended-reach hedge trimmers

a) **To reduce the risk of electrocution, never use the extended-reach hedge trimmer near any electrical power lines.** Contact with or use near power lines may cause serious injury or electric shock resulting in death.

b) **Always use two hands when operating the extended-reach hedge trimmer.** Hold the extended-reach hedge trimmer with both hands to avoid loss of control.

c) **Always use head protection when operating the extended-reach hedge trimmer overhead.** Falling debris can result in serious personal injury.

Specific safety instructions for extended-reach hedge trimmer

a) If any parts are damaged or missing, do not operate this product until the parts are replaced. Use of this product with damaged or missing parts could result in serious personal injury.

b) Do not attempt to modify this product or create accessories not recommended for use with this product. Any such alteration or modification is misuse and

could result in a hazardous condition leading to possibly serious personal injury.

- c) Never attach or adjust any attachment while the power head is running or with the battery installed. Failure to stop the motor and remove the battery pack may cause serious personal injury.
- d) Clear the foreign objects e.g. wire fences, hidden wiring, nails, weeds or rubbish within the hedges and bushes before operating the extended-reach hedge trimmer.
- e) Always use two hands when operating the extended-reach hedge trimmer. Hold the extended-reach hedge trimmer with both hands to avoid loss of control.
- f) Do not use on a ladder, roof top, tree, or other unstable support. Stable footing on a solid surface enables better control of the hedge trimmer in unexpected situations.
- g) The user should make sure that the locking devices of any moving elements (e.g. the extended shaft and pivoting element), if any, are in the locked position before operating the extended-reach hedge trimmer.

Specific safety instructions for extended-reach hedge trimmer

Cleaning and Maintenance

- a) When servicing, use only identical replacement parts. Use of any other parts may create a hazard or cause product damage. To ensure safety and reliability, all repairs should be performed by a qualified service technician.
- b) To prevent serious personal injury, remove the battery pack from the power head before inspecting, cleaning, performing maintenance or changing add-on attachments. A battery operated tool with the battery pack inserted is always on and can start accidentally.
- c) Avoid using solvents when cleaning plastic parts. Most plastics are susceptible to damage from various types of commercial solvents and may be damaged by their use. Use a clean cloth to remove dirt, dust, oil, grease, etc.
- d) When cleaning the hedge trimmer attachment, DO NOT immerse it in water or other liquids.

Additional safety instructions for pole saw

Assembly

- a) If any parts are damaged or missing, do not operate this product until the parts are replaced. Use of this product with damaged or missing parts could result in serious personal injury.
- b) Do not attempt to modify this product or create accessories not recommended for use with this pole saw. Any such alteration or modification is misuse and could result in a hazardous condition leading to possibly serious personal injury.

Operation

- a) **Keep all parts of the body away from the saw chain.** Do not remove cut material or hold material to be cut when blades are moving. Make sure the switch is off when clearing jammed material. Saw chain continues to move after the switch is turned off. A moment of inattention while operating the pole saw may result in serious personal injury.
- b) **Carry the pole saw by the handle with the saw chain stopped. When transporting or storing the pole saw, always fit the saw chain device cover.** Proper handling of the pole saw will reduce possible personal injury from the saw chain.
- c) **Hold the pole saw by insulated gripping surfaces only, because the saw chain may contact hidden wiring. A saw chain contacting a “live” wire may make exposed metal parts of the pole saw “live” and could give the operator an electric shock.**
- d) **Do not use the pole saw in bad weather conditions, especially when there is a risk of lightning. This decreases the risk of being struck by lightning.**
- e) **To reduce the risk of electrocution, never use near any electrical power lines. Contact with or use near power lines may cause serious injury or electric shock resulting in death.**
- f) **Always use two hands when operating the pole saw. Hold the pole saw with both hands to avoid loss of control.**
- g) **Always use head protection when operating the pole saw overhead. Falling debris can result in serious personal injury.**
- h) **Never attach or adjust any attachment while the power head is running or with the battery installed. Failure to stop the motor and remove the battery may cause serious personal injury.**
- i) **Once assembled correctly, the pole saw attachment, extension pole and the power head should not separate when pulled. Always test the connection by pulling on them. Repeat the steps above if the pieces can be separated.**
- j) **Never cut near power lines, electric cords, or other electric sources. If the bar and chain jams on any electrical cord or line, DO NOT TOUCH THE BAR, CHAIN**

OR THE ALUMINUM POLE! THEY CAN BECOME ELECTRICALLY LIVE AND MAY BE VERY DANGEROUS. Continue to hold the pole saw by the insulated rear handle or lay it down and away from you in a safe manner. Disconnect the electrical service to the damaged line or cord before attempting to free the bar and chain from the line or cord. Contact with the bar, chain, other conductive parts of the pole saw, or live electric cords or lines will result in death by electrocution or serious injury.

- k) Do not allow familiarity with this product to make you careless. Remember that a careless fraction of a second is sufficient to inflict serious injury.
- l) Always wear safety goggles or safety glasses with side shield marked to comply with ANSI Z87.1. Failure to do so could result in objects being thrown into your eyes and other possible serious injuries.
- m) Do not use any attachments or accessories not recommended by the manufacturer of this product. The use of attachments or accessories not recommended can result in serious personal injury.

Maintenance

- a) When servicing, use only identical replacement parts. Use of any other parts may create a hazard or cause product damage. To ensure safety and reliability, all repairs should be performed by a qualified service technician.
- b) Battery tools do not have to be plugged into an electrical outlet; therefore, they are always in operating condition. To prevent serious personal injury, take extra precautions and care when performing maintenance, service or for changing the cutting attachment or other attachments.
- c) To prevent serious personal injury, remove the battery pack from the power head before servicing, cleaning, changing add-on attachments or when the product is not in use.
- d) Before performing any maintenance, make sure that the battery pack is removed. Failure to heed this warning could result in serious personal injury.
- e) Always wear gloves when handling the bar and chain; these components are sharp and may contain burrs.
- f) Never touch or adjust the chain while the motor is running. The saw chain is very sharp; always wear protective gloves when performing maintenance to the chain.
- g) Store Idle Appliances Indoors - When not in use, appliances should be stored indoors in a dry and high or locked-up place with the battery pack removed- out of reach of children.
- h) Maintain Appliance with Care - Keep cutting edge sharp and clean for best performance and to reduce the risk of injury. Follow instructions for lubricating and changing accessories. Keep handles dry, clean, and free from oil and grease.

- i) **Check Damaged Parts** - Before further use of the product, a guard or other part that is damaged should be carefully checked to determine that it will operate properly and perform its intended function. Check for alignment of moving parts, binding of moving parts, breakage of parts, mounting, and any other condition that may affect its operation. A guard or other part that is damaged should be properly repaired or replaced by an authorized service center unless indicated elsewhere in this manual.
- j) Do not charge the battery pack in rain, or in wet locations.

Additional safety instructions for lawn trimmer

IMPORTANT

READ CAREFULLY BEFORE USE

KEEP FOR FUTURE REFERENCE

Safe operating practices

Training

- a) Read the instructions carefully. Be familiar with the controls and the correct use of the machine.
- b) Never allow children or people unfamiliar with these instructions to use the machine. Local regulations can restrict the age of the operator.
- c) Keep in mind that the operator or user is responsible for accidents or hazards occurring to other people or their property.

Preparation

- a) Before use, always visually inspect the machine for damaged, missing or misplaced guards or shields.
- b) Never operate the machine while people, especially children, or pets are nearby.

Operation

- a) Wear eye protection and stout shoes at all times while operating the machine.
- b) Avoid using the machine in bad weather conditions especially when there is a risk of lightning.
- c) Use the machine only in daylight or good artificial light.
- d) Never operate the machine with damaged guards or shields or without guards or shields in place.

- e) Switch on the motor only when the hands and feet are away from the cutting means.
- f) Always disconnect the machine from the power supply
 - 1) whenever the machine is left unattended;
 - 2) before clearing a blockage;
 - 3) before checking, cleaning or working on the machine;
 - 4) after striking a foreign object;
 - 5) whenever the machine starts vibrating abnormally.
- g) Take care against injury to feet and hands from the cutting means.
- h) Always ensure that the ventilation openings are kept clear of debris.

Maintenance and storage

- a) Disconnect the machine from the power supply before carrying out maintenance or cleaning work.
- b) Use only the manufacturer's recommended replacement parts and accessories.
- c) Inspect and maintain the machine regularly. Have the machine repaired only by an authorized repairer.
- d) When not in use, store the machine out of the reach of children.

Additional safety instructions for brush cutter

Training

- a) Read the instructions carefully. Be familiar with the controls and the proper use of the machine.
- b) Never allow people unfamiliar with these instructions or children to use the machine. Local regulations can restrict the age of the operator.
- c) Keep in mind that the operator or user is responsible for accidents or hazards occurring to other people or their property.

Preparation

- a) Never operate this product while people, especially children or pets are nearby.
- b) Wear eye protection and stout shoes at all times while operating this product.
- c) The distance between the machine and bystanders shall be at least 15m.
- d) The 3-teeth blades of brush cutters shall be well packed during transport to prevent personal injury or damage.

Operation

- a) Do not operate the brush cutter when the operator is tired, ill or under the influence of alcohol or drugs.
- b) Keep bystanders, children and pets at least 15m away from the machine while it is in operation.
- c) Never operate the brush cutter with damaged guards or shields or without guards or shields in place.
- d) Wear eye protection, hearing protection and stout shoes at all times while operating the machine.
- e) Take care against injury to feet and hands from the cutting means.

Noise and Vibration Declaration

The declared vibration total value and the declared noise emission values have been measured in accordance with a standard test method and may be used for comparing one tool with another. The declared vibration total value may also be used in a preliminary assessment of exposure.

Warning!

The vibration and noise emission during actual use of the power tool can differ from the declared total value depending on the ways in which the tool is used, in particular, what kind of work piece is machined.

It is necessary to identify safety measures to protect the operator that are based on an estimation of exposure in the actual conditions of use (taking account of all parts of the operating cycle such as the times when the tool is switched off and when it is running idle in addition to the trigger time)

Try to minimize the impact of vibration and noise. Exemplary measures to reduce vibration exposure include wearing gloves while using the tool, limiting working time, and using accessories in good condition.

Special Safety Instructions for Battery packet and Charger

If under extreme conditions any electrolyte should escape from the battery, it's essential to avoid contact with skin. If electrolyte does come into contact with your skin, rinse it off with water. In the event of electrolyte contact with your eyes, it's essential to consult a doctor.

- a) This appliance is not intended for use by persons (including children) with reduced

physical, sensory or mental capabilities, or lack of experience and knowledge, unless they have been given supervision or instruction concerning use of the appliance by a person responsible for their safety.

- b) Children should be supervised to ensure that they do not play with the appliance.
- c) Before the use of the charger, read the instruction manual for it carefully.
- d) During the charge process, the current used should correspond to the current of the battery charger.
- e) Never let moisture, rain or splashed water reaches the charging location.
- f) The ambient temperature must not exceed 40oC. Never expose the device to direct insulation.
- g) If the electrical cable is damaged, the wire may only be replaced by the supplier or by his repair workshop. Have repairs carried out only by an authorized specialist only.
- h) Always keep the surface of the charger free from dust and dirt.
- i) Do not throw batteries into water or fire, risk of explosion!
- j) Never discharge the battery completely and recharge occasionally if not used for a prolonged period.

This 40V power head A40DG 65B01 may be used with only the following HENX attachments or subsequently introduced by HENX for use with this power head:

ATTACHMENT TYPE	MODEL NUMBER
Brush cutter	AS-DCG350
Line trimmer	
Pole saw	AS-GZJ10
Pole hedge trimmer	AS-GZX20

BATTERY	CHARGER
A40B25B01	A40KC250B01
A40B50B01	A40MC75B01
A40B75B01	

Residual risks







Even when the tool is used as prescribed it is not possible to eliminate all residual risk factors. The following hazards may arise in connection with the tool's construction and design:









1. Damage to lungs if an effective dust mask is not worn.
2. Damage to hearing if effective hearing protection is not worn.
3. Health defects resulting from vibration emission if the power tool is being used over longer period of time or not adequately managed and properly maintained.

WARNING! This machine produces an electromagnetic field during operation. This field may under some circumstances interfere with active or passive medical implants. To reduce the risk of serious or fatal injury, we recommend persons with medical implants to consult their physician and the medical implant manufacturer before operating this machine.

SAFETY SYMBOLS

The purpose of safety symbols is to attract your attention to possible dangers. The safety symbols and the explanations with them deserve your careful attention and understanding. The symbol warnings do not, by themselves, eliminate any danger. The instructions and warnings they give are no substitutes for proper accident prevention measures. Read, understand, and follow all safety symbols on the machine before trying to assemble and operate it.

	Safety Alert	Indicates a potential personal injury hazard.
	Read Operator's Manual	To reduce the risk of injury, user must read and understand the operator's manual before using this product.
	Wear Protection Eye	Always wear safety goggles or safety glasses with side shields and a full face shield when operating this product.
	Wear Protection Ear	Always wear sound barriers (ear plugs or ear muffers) to protect your hearing.
	Wear Protection Head	Wear an approved safety Standard hat to protect your head.
	Wear Protective Gloves	Protect your hands with gloves when handling blade or blade guard. Heavy-duty, nonslip gloves improve your grip and protect your hands.
	Wear Safety Footwear	Wear non-slip safety footwear when using this equipment.

	Danger- Keep hands Away from Blades	Contact with blade will result in serious personal injury.
	Keep sufficient distance away from electrical power lines	To prevent electrocution, do not operate within 33 ft. (10m) of overhead electrical lines. Contact with or use near power lines may cause serious injury or electric shock resulting in death.
	Falling objects	Be aware of falling objects during the operation of pole saw and extended-reach hedge trimmer.
	Noise label	A noise label marked with the declared noise emission value shall be shown on the machine.
	Do not expose to rain	Do not expose the machine to rain.
	DANGER — Keep Bystanders Away	Do not operate the machine when children or others are nearby.
	Blade thrust	Be aware of blade thrust during operation
	Keep bystanders away	Ensure that other people and pets remain at least 15m away from the liner trimmer when it is in use.
	Max. speed for output spindle	Max. speed for output spindle of grass trimmer and brush cutter shall be marked on the machine.

Power Head A40DG65B01

SPECIFICATIONS

Voltage	40 V 
Weight (Without battery pack)	3.12 kg

PACKING LIST

40V A40DG65B01 power head	1
Brush Cutter attachment	1
Liner trimmer attachment	1
Extended Reach Hedge Trimmer attachment	1
Pole saw attachment	1
Front-assist handle	1
Single shoulder strap	1
Operator's manual	1
Hex wrench	1

DESCRIPTION

Refer to Fig. A for different parts of power head as follows.

1. Locking knob
2. Pipe joint
3. Front-assist handle
4. Shoulder-strap Mount Hanger
5. Control panel
6. Lock-off button
7. Trigger
8. Air outlet
9. Air inlet
10. Electric Contacts

- 11. Ejection mechanism
- 12. Battery-release button
- 13. Single Shoulder Strap (special accessory)
- 14. Tongue

ASSEMBLY

⚠ WARNING: If any parts are damaged or missing, do not operate this product until the parts are replaced. Use of this product with damaged or missing parts could result in serious personal injury.

⚠ WARNING: Always remove the battery pack from the product when you are assembling parts, making adjustments, cleaning, or when the product is not in use.

Installing An Attachment to the Power Head

⚠ WARNING: Read and understand entire Operator’s Manual for each optional attachment used on this power head and follow all warnings and instructions. Failure to follow all instructions could result in electric shock, fire and/or serious personal injury.

⚠ WARNING: This 40V power head A40DG65B01 is designed to be used only with the HENX attachment models that are specified in this Operator’s Manual or subsequently introduced by HENX for use with this power head. Use of other, unauthorized attachments could cause serious personal injuries or property damage.

⚠ WARNING: Never install, remove, or adjust any attachment while the power head is running or with the battery installed. Failure to stop the motor and remove the battery can cause serious personal injury. NEVER OPERATE THE POWER HEAD WITHOUT AN ATTACHMENT.

The attachment connects to the power head by means of a coupler device.

1. Stop the motor and remove the battery pack.
2. Loosen the wing knob.
3. Remove the end cap from the attachment shaft. Align the bulge on the attachment shaft with the slot on the coupler and push the attachment shaft into the coupler until you hear a clear “click” sound, which indicates that the attachment shaft is mounted into place.

Fig. B parts description see below:

1	Power head shaft	4	Bulge
2	Wing knob	5	Attachment shaft
3	Slot	6	Coupler

4. Pull the attachment shaft to verify whether it is securely locked into the coupler. If not, rotate the attachment shaft from side to side in the coupler until it snaps into place.
5. Tighten the wing knob securely.

Removing the Attachment From the Power Head

1. Stop the motor and remove the battery pack.
2. Loosen the wing knob.
3. Pull or twist the attachment shaft out of the coupler.

Mounting and Adjusting the Front-assist Handle

1. Stop the motor and remove the battery pack, if installed.
2. Loosen 4 screws on front-assist handle upper cover to separate the upper cover from adjustable front-assist handle (Fig. C).

Fig. C parts description see below:

1	Hex screw	3	Front-assist handle lower cover
2	Front-assist handle upper cover		

3. Adjust the front-assist handle lower cover until it locates in a proper position within threshold ring (Fig. D).
4. Lock the front-assist handle upper cover by tightening the hex screws (Fig. E).

⚠ WARNING: Never operate the tool without the front-assist handle firmly in place.

⚠ WARNING: Only fix the front-assist handle between the threshold ring and the coupler.

Mounting the Shoulder Strap

Depress the strap hook to open it and attach it onto shoulder-strap mount hanger on the power head (Fig. F).

Note: quick-release mechanism: pull the tongue by your fingers, the shoulder strap will be taken off from the operator's body under the weight of the machine.

OPERATION

Installing/Removing the Battery Pack

To Install

Align the battery ribs with the mounting slots and press the battery pack down until you hear a “click” (Fig. G).

To Remove

Depress the battery-release button and pull the battery pack out (Fig. H).

Starting/Stopping the Power Head (Fig. I)

To Start

Press down the on-off button on control panel and hold it in that position and then press down the lock-off button and the trigger simultaneously to turn on the power head. Different forces on the trigger results in different rotating speed of the power head. The larger the force, the higher the speed.

To Stop

Release the trigger.

NOTICE: The motor runs only when the lock-off button and trigger are both pressed.

Speed Adjustment Function (Fig. J)

There are 3 buttons on the power head control panel . “No. 1” is power indicator button, “No. 2” is on/off button and “No 3” is the high/low speed button . The machine starts at high speed by default, press the No.3 button to switch to low speed and press it again to switch to high speed.

Parts description see the Figure J:



MAINTENANCE

⚠ WARNING: Before inspecting, cleaning or servicing the unit, stop the motor, wait for all moving parts to stop, and remove the battery pack. Failure to follow these instructions can result in serious personal injury or property damage.

⚠ WARNING: When servicing, use only identical replacement parts. Use of any other parts can create a hazard or cause product damage. To ensure safety and reliability, all repairs, other than the items listed in these maintenance instructions, should be performed by a qualified service technician.

NOTICE: Before each use, inspect the entire product for damaged, missing, or loose parts such as screws, nuts, bolts, caps, etc. Tighten securely all fasteners and caps and do not operate this product until all missing or damaged parts are replaced. Please contact customer service or a qualified service technician.

General Maintenance

Avoid using solvents when cleaning plastic parts. Most plastics are susceptible to damage from various types of commercial solvents and may be damaged by their use. Use clean cloths to remove dirt, dust, oil, grease, etc.

Cleaning the Power Head

1. Stop the motor and remove the battery pack.
2. Clean dirt and debris from the power head using a damp cloth with a mild detergent.

NOTICE: Do not use any strong detergents on the plastic housing or the handle. They can be damaged by certain aromatic oils such as pine and lemon.

Storing the Power Head

1. Remove the battery pack from the power head before storing.
2. Clean all foreign material from the power head.
3. Store it in a place that is inaccessible to children.
4. Keep away from corrosive agents such as garden chemicals and deicing salts.

HEDGE TRIMMER ATTACHMENT

SPECIFICATIONS

Blade Length	20"(510mm)
Cutting Capacity	1" (26mm)
Weight (including blade guard)	5.40lbs (2.45kg)

DESCRIPTION

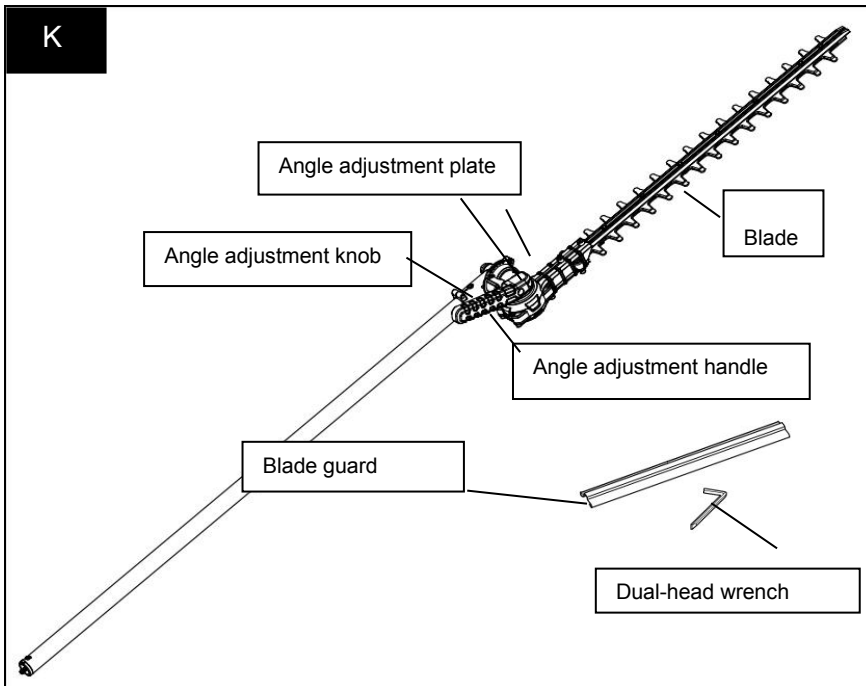

Connection Shaft

Connecting extended-reach hedge trimmer with A40DG65B01 power head.

Angle Adjustment Knob/Plate/Handle

Adjust the blade of extended-reach hedge trimmer to its ideal working position.

Blade

Hardened steel blades for cutting hedges and shrubs.

Blade Guard

Safeguards against contact with the sharp blades when the tool is not in use. Protects the blades from damage when the tool is in transportation and storage.

Dual-head Wrench

Lock/unlocks the hex head lubrication bolt.

ASSEMBLY

Unpacking

This product requires assembly.

Carefully remove the product and any accessories from the box. Make sure that all items listed in the packing list are included.

Inspect the tool carefully to make sure that no breakage or damage occurred during shipping.

Do not discard the packing material until you have carefully inspected and satisfactorily operated the tool.

If any parts are damaged or missing, please return the product to the place of purchase.

Adjusting the Blade

- When the hedge trimmer is removed from the package, it is folded in its storage position with the blade against the shaft (Fig. L). Adjust the blade to a suitable working position before attaching it to the power head.

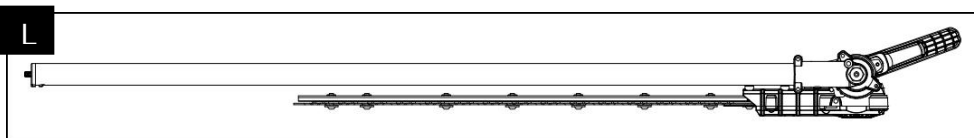

- There are 12 possible working positions (Fig. C). The angle of the blade can be adjusted upwards to any of 5 positions, from 0 (straight) to 45, and downwards to any of 7 positions, from 0 to 90 (right angle facing down).

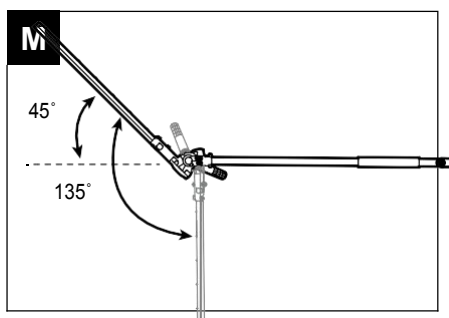

- While pressing the release trigger, rotate the adjusting lever to adjust the blade to the desired cutting position.

Once the desired position has been reached, release the release-trigger. An audible click indicates that the locking in is engaged in the locking plate (Fig.N).

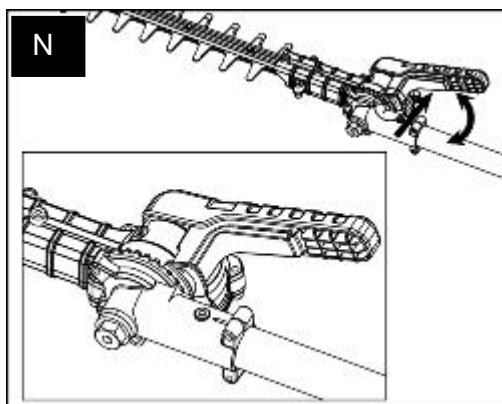

⚠ WARNING! To reduce the risk of injury, remove the battery before making adjustments and make adjustments only when the blades are at a standstill. Never touch the blades while making adjustments.

⚠ WARNING! To reduce the risk of injury, always stop the tool, remove the battery, and cover the blade with the blade guard before moving the blade to the storage position or from the storage position to the normal working position.

Connecting the Hedge Trimmer Attachment to the Power Head

This extended-reach hedge trimmer attachment is designed for use with HENX Power Head A40DG65B01. The extended-reach hedge trimmer attachment connects to the power head by means of a coupling device.

1. Stop the motor and remove the battery pack.
2. Loosen the wing knob 
3. Align the bulge on the extended-reach hedge trimmer shaft with the arrow on the coupler (Fig. O) and push the extended-reach hedge trimmer shaft into the coupling until you hear a clear “click” sound.
4. Pull the shaft of the hedge trimmer to verify that it is securely locked into the coupling. If not, rotate the hedge trimmer shaft from side to side in the coupling until it snaps into place.
5. Tighten the wing knob securely.

⚠ WARNING! Be certain the wing knob is fully tightened before operating the tool and check it periodically for tightness during use to avoid serious personal injury.

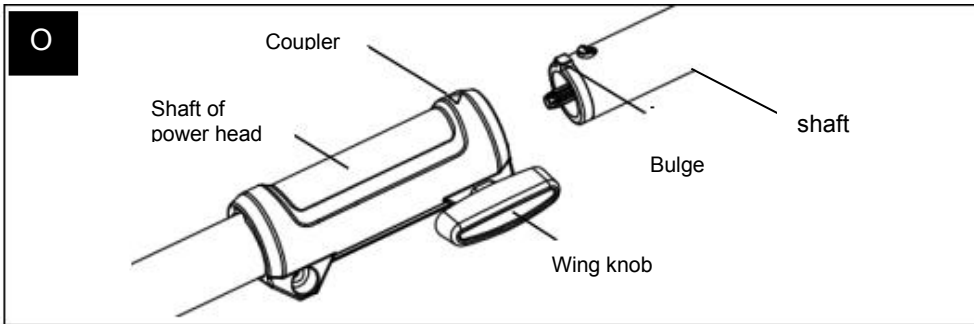

OPERATION

Before each use, inspect the whole product for damaged, missing or loose parts such as screws, nuts, bolts, caps etc. Tighten securely all fasteners and caps and do not operate this product until all missing or damaged parts are replaced.

Applications

You may use this product for trimming hedges, shrubs, scrub, bushes and similar material with a branch diameter of less than 1 inch.

Using the Extended-reach Hedge Trimmer with Power Head

⚠WARNING: Dress properly to reduce the risk of injury when operating this tool. Do not wear loose clothing or jewelry. Wear eye and ear/hearing protection. Wear heavy, long pants, boots, and gloves. Do not wear short pants or sandals or go barefoot.

Preparation for Cutting

Refer to “SAFETY INSTRUCTIONS” earlier in this manual for appropriate safety equipment.

1. Adjust the cutting blade to the desired working position.
2. Remove the blade guard from the blade.

Working Techniques

Horizontal Cutting (with blade at an angle)

Cut close to the ground from a standing position, e.g. for trimming low shrubs.

Swing the blade right and left as you move

along the hedge – use both sides of the blades and do not rest the cutter blade on the

ground (Fig.P).

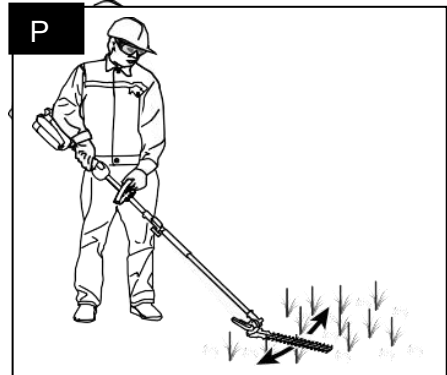

Horizontal Cutting(with straight blade)

Hold the blade at an angle of 0° to 10° as you slowly swing the hedge trimmer horizontally. Swing the blade in an arc towards the outsides of the hedge so that the cuttings are swept to the ground (Fig. Q).

Recommendation: Cut hedges that are no more than chest height in this working position.

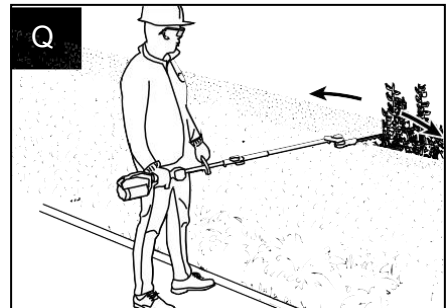

Vertical Cutting(with blade at an angle)

This is useful when cutting without standing directly next to the hedge, e.g. , there is a flowerbed between operator and hedge.

In this situation, it is best to connect the hedge trimmer to the power head in the side-cutting position (see Fig. R).

Vertical Cutting (with straight blade)

Slowly swing the blade up and down in an arc as you move along the hedge—use both sides of the blade(Fig. S).

Overhead Cutting (with blade at an angle)

Hold the hedge trimmer vertically and slowly swing it in an arc to make maximum use of its reach (Fig. T).

⚠ WARNING: any overhead working position is tiring.

To minimize the risk of accidents, work in such positions for short periods only.

Set the angle of the blade to maximum so that the tool can be held in a lower, less tiring position while still providing adequate reach.

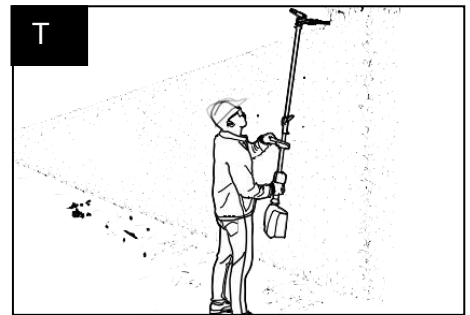
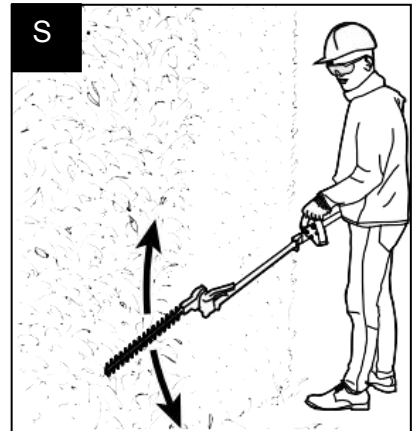
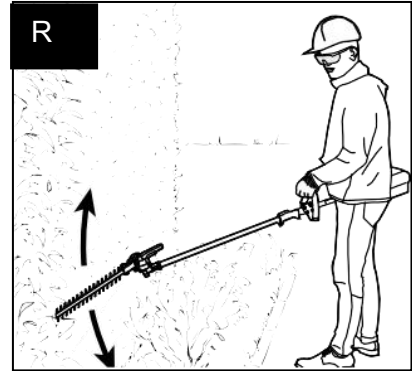

To Start/Stop the Tool

See "STARTING/STOPPING THE POWER HEAD" section in the power head A40DG65B01operator's manual.

MAINTENANCE

Cleaning

- Use a soft brush to remove debris from all air intakes and cutting blades.
- To remove pitch and other sticky residue, spray the blades with resin solvent. Run the motor briefly so that the solvent is evenly distributed.
- Do not use any strong detergents on the plastic housing or the handle. They can be damaged by certain aromatic oils, such as pine and lemon, and by solvents such as kerosene. Moisture can also cause a shock hazard. Wipe off any moisture with a soft dry cloth. NEVER use water for cleaning the tool.

All hedge trimmer service, other than the items listed in these maintenance instructions, should be performed by competent hedge trimmer service personnel.

Replacing the Blade(Fig. U)

⚠WARNING: Always wear gloves when handling the blade; these components are very sharp and may contain burrs.

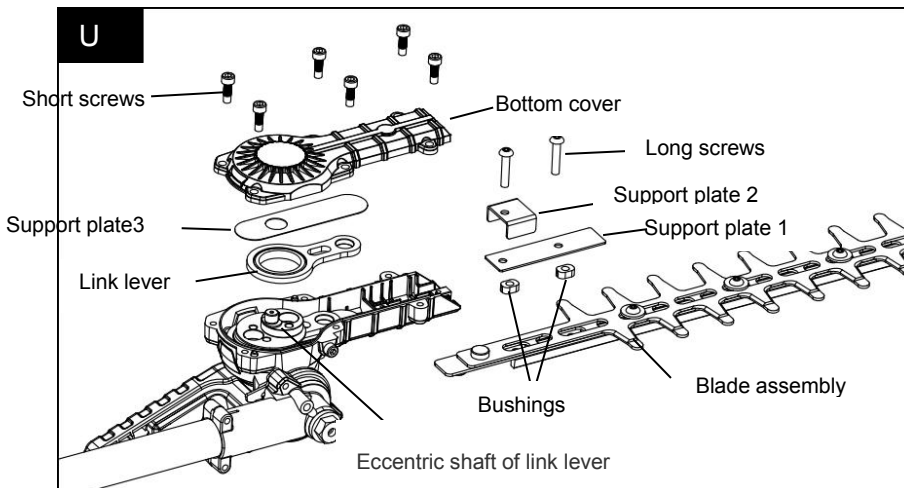

1. Stop the motor and remove the battery pack.
2. Adjust the blade to the horizontal position, ensuring that the blade assembly is in line with the hedge trimmer shaft for easy mounting (Fig. U).
3. Use a 4mm hex wrench (not included) to loosen the 6 screws (short screws) in the bottom cover and remove them.
4. Continue loosening the 2 screws (long screws) to remove the support plate 1 & 2, as well as the 2 bushings. The 2 bushings are separately located inside the two rounded rectangle slots in the blade assembly.
5. Remove the support plate 3.
6. Carefully remove the link lever from the bushings.
7. Remove the blade assembly from the tool and replace it with a new one.
8. Align the inward bulge on the screw holes assembly with the hole inside the eccentric block assembly to install the new blade assembly into place.
9. Insert the two bushings into the two rounded rectangle slots separately.
10. Mount the support plate 1 and then mount the support plate 2.
11. Keep the inside holes in the blade, the bushings, and the holes in the support plates in line with the screw holes in the gear case. Install the 2 long screws into the aligned holes and tighten them securely (Fig. V).

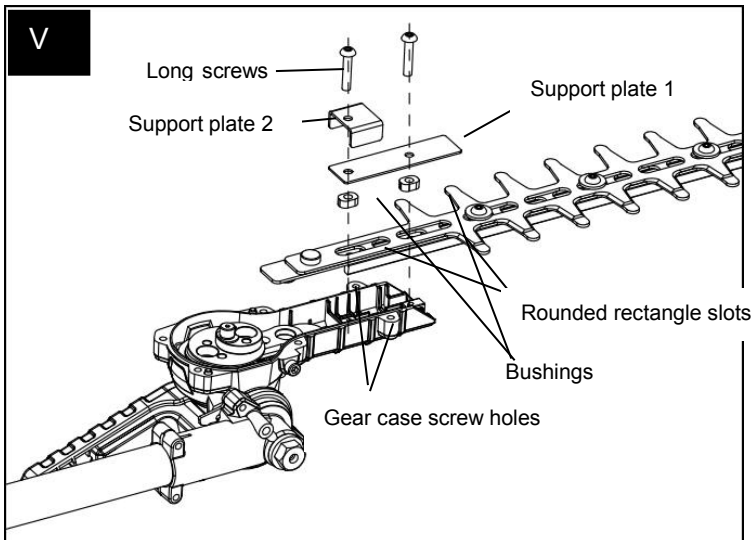

12. Slightly move the blade forward and backward to check whether the blade can move freely. If not, reassemble the blade until the upper blade can move freely.

13. Install the link lever with its bulge facing the blade(Fig. W).

14. Align the hole of support plate3 with the bulge on the eccentric block assembly to install the support plate into place, ensuring that the Plate is exactly located in the center, parallel to both edges.

15. Mount the bottom cover onto the gear case

and secure it with 6 short screws(Fig X).

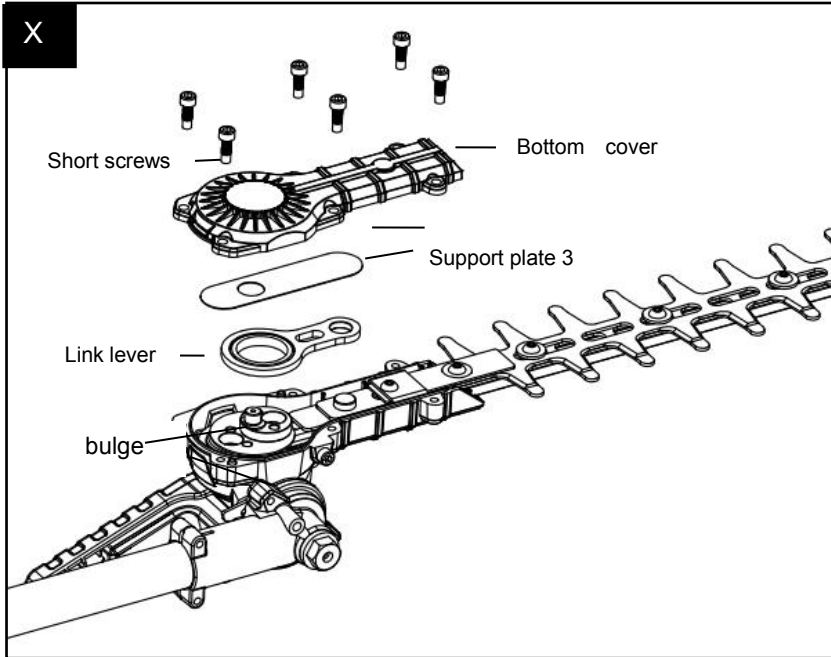
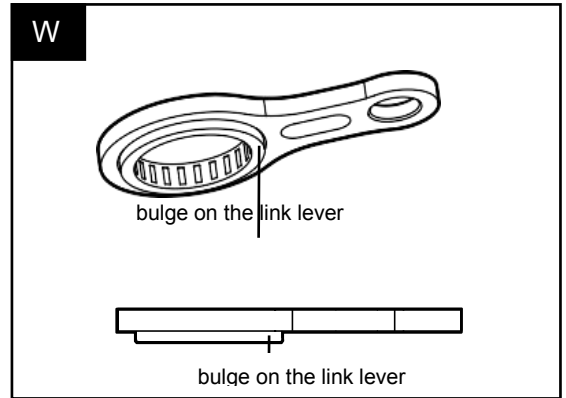

16. Start the extended-reach hedge trimmer to check whether the extended reach hedge trimmer can work normally. If it does not, reassemble following the above steps.

Sharpening the Blade

When cutting performance and behavior begin to deteriorate, re-sharpen the blades. It is recommended to have the blades re-sharpened by a qualified service technician.

NOTICE: Do not operate your extended reach hedge trimmer with dull or damaged blades. This may cause overload and will give unsatisfactory cutting results.

Lubricating the Blade

To prevent rust, it is recommended to lubricate the blades with anti-rusting oil when it is stored for long time.

If the upper blades are aligned completely with the lower ones, start the hedge trimmer and then stop it to offset the blades before lubrication (Fig.Y).

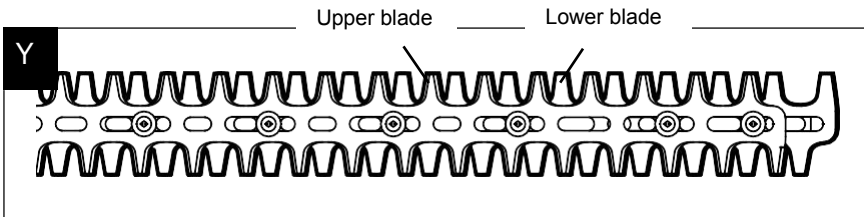

⚠ WARNING: Blades are sharp. When handling the blade assembly, wear non-slip, heavy-duty protective gloves. Do not place your hand or fingers between blades or in any position where they could get pinched or cut. NEVER touch blades or service the unit with battery pack installed.

Transmission Gears Lubrication

The transmission gears in the gear case need to be lubricated periodically with gear grease. Check the gear case grease lever approximately every 50 hours of operation by removing the sealing screw on the gear case. There are three sealing screws: one on the side and two on the top.

If no grease can be seen on the flanks of the gear, follow the steps below to fill with gear grease to 3/4 capacity.

Do not completely fill the transmission gears.

1. Depending on which screw you are removing, lay the extended-reach hedge trimmer on its back or hold it on its side so that the sealing screw to be removed is facing upwards(Fig. Z & 1).

3. Use the dual-head wrench to loosen and remove the sealing screw.
4. Use a grease gun(not included)to inject some grease into the screw hole; do not exceed3/4capacity.
5. Tighten the sealing screw after injection.

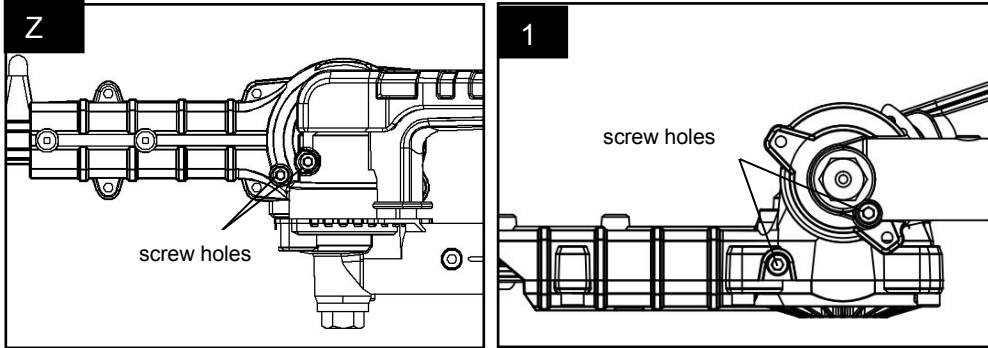

Transporting and Storing

- Remove the battery pack from the tool.
- Clean the tool thoroughly before storing it.
- Put on the blade guard onto the cutting blade before storing or transporting. Use caution to avoid the sharp teeth of the blades. For saving space, fold the hedge trimmer to its storage position (see Fig. B).
- If the hedge trimmer is removed from the power head and stored separately,
 - fit the end cap onto the hedge trimmer shaft to avoid getting dirt into the coupling.
- Store the unit in a dry, well-ventilated area, locked-up or up high, out of the reach of children. Do not store the unit on or adjacent to fertilizers, gasoline, or other chemicals.

TROUBLESHOOTING

PROBLEM	CAUSE	SOLUTION
<p>Hedge trimmer doesn't work.</p>	<ul style="list-style-type: none"> ▪ The battery pack is not attached to the power head. ▪ No electrical contact between the trimmer and battery. ▪ The battery pack is depleted. ▪ The lock-off button is not pressed before pressing the trigger switch. ▪ The battery pack or power head is too hot. ▪ The blade is jammed. ▪ The hedge trimmer is not well connected with the power head. 	<ul style="list-style-type: none"> ▪ Attach the battery pack to the power head. ▪ Remove battery, check contacts and re-install the battery pack. ▪ Charge the battery pack. ▪ Press down the lock-off lever and hold it, then press the trigger to turn on the hedge trimmer. ▪ Allow the battery pack or power head to cool until the temperature drops below 152°F (67°C). ▪ Remove the battery pack from the tool. Remove the obstruction carefully and then reinsert the battery and restart the tool. ▪ Disconnect the hedge trimmer from the power head. Reconnect them following the section " CONNECTING THE HEDGE TRIMMER ATTACHMENT TO THE POWER HEAD" in this manual.
<p>Excessive vibration or noise.</p>	<p>Dry or corroded blades. Blades or blade support is bent.</p> <p>Bent or damaged teeth.</p> <p>Loose blade bolts.</p>	<p>Lubricate the blades.</p> <p>Replace with a new blade or support following the section " REPLACING THE BLADE" in this manual or contact HENX service center for replacement.</p> <p>Replace with a new blade following the section " REPLACING THE BLADE" in this manual or contact HENX service center for replacement.</p> <p>Tighten the blade bolts. Using a 3mm hex wrench (not included), turn the bolt clockwise to tighten.</p>

POLE SAW ATTACHMENT

SPECIFICATIONS

Guide Bar Length	10" (250mm)
Chain Pitch	3/8" (9.5mm)
Chain Gauge	0.051" (1.3mm)
Chain Oil Tank Capacity	260ml
Weight	1.72 kg

PACKING LIST

PART NAME	QUAN TITY
Pole Saw Attachment	1
Chain Sheath	1
Dual-head Wrench	1
Operator's Manual	1
Guide bar 100SDEA041	1
Chain 91PX040E	1

Recommended Bar and Chain for this Pole Saw

PART NAME	MODEL NUMBER
Guide Bar	104MLEA041
Saw Chain	90PX040X

DESCRIPTION

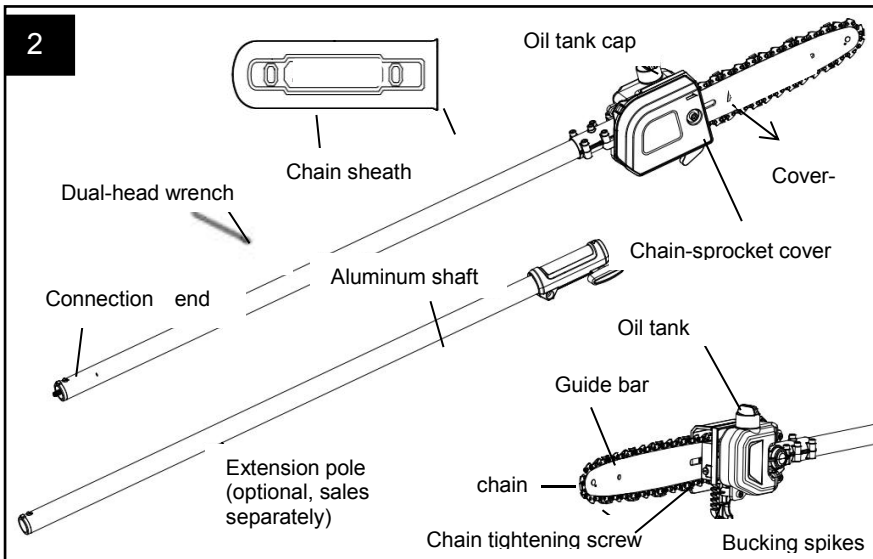

Chain Sheath

The chain sheath keeps the operator from coming in contact with the sharp chain blades when the tool is not in use. It also helps keep the chain blades from being nicked or damaged when the tool is in transportation and storage.

Dual-Head Wrench

Lock/unlocks the hex head bolt and the flat screw.

Connection End

Connect with power head A40DG65B01.

Cover-Screw

Locks/unlocks the chain-sprocket cover.

Chain-Sprocket Cover

Covers the chain-sprocket and secures the guide bar.

Oil Tank

Stores the lubricant for the saw chain and allows user to see when to add lubricant by means of the semi-transparent tank housing.

Oil-Tank Cap

Seals the oil tank.

Guide Bar

Supports and guides the saw chain.

Saw Chain

A loop of chain having cutting teeth that cuts the wood when it is driven by the power head and supported by the guide bar.

Chain-Tightening Screw

For tension or release the saw chain.

Bucking Spikes

The pointed tooth or teeth for use when felling or bucking to pivot the saw and maintain position while sawing.

ASSEMBLY

Unpacking

This product requires assembly.

Carefully remove the product and any accessories from the box. Make sure that all items listed in the packing list are included.

Inspect the tool carefully to make sure that no breakage or damage occurred during shipping.

Do not discard the packing material until you have carefully inspected and satisfactorily operated the tool.

If any parts are damaged or missing, please return the product to the place of purchase.

Connecting the Pole Saw Attachment to the Power Head

⚠WARNING: Never attach or adjust any attachment while the power head is running or with the battery installed. Failure to stop the motor and remove the battery may cause serious personal injury.

This pole saw attachment is designed for use with HENX Power Head A40DG65B01.

The pole saw attachment connects to the power head by means of a coupling device.

- Stop the motor and remove the battery pack.
- Loosen the wing knob.
- Remove the end cap from the pole saw attachment. Align the arrow on the pole saw shaft with the arrow on the coupler and push the pole saw shaft into the coupler until you hear a clear “click” sound which indicates the pole-saw shaft is mounted into place.
- Pull the shaft of the attachment to verify it is securely locked into the coupling. If not, rotate the pole-saw shaft from side to side in the coupling until it snaps into place.
- Tighten the wing knob securely.

⚠WARNING: Be certain that the wing knob is fully tightened before operating the equipment; check it periodically for tightness during use to avoid serious personal injury.

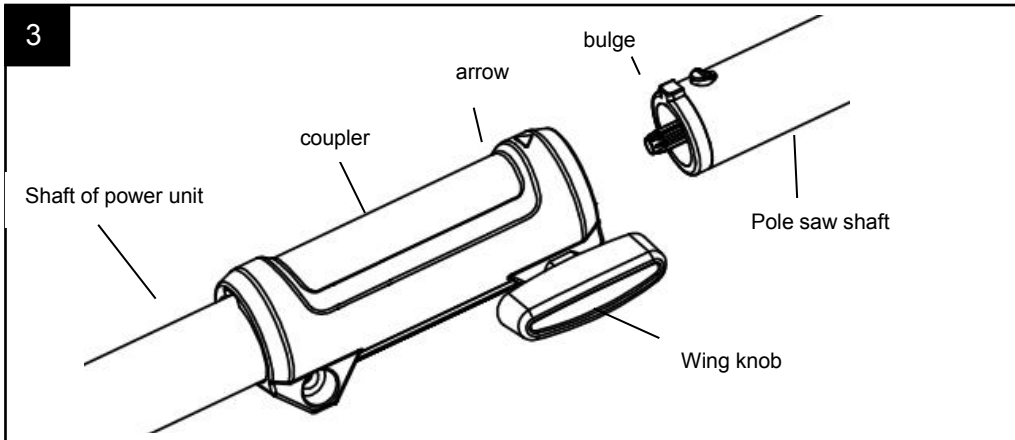

Connecting the Extension Pole between the Power Head and the Pole Saw Attachment (Available Separately)

⚠ WARNING: Never attach or adjust any attachment while the power head is running or with the battery installed. Failure to stop the motor and remove the battery may cause serious personal injury.

This extension pole is designed for exclusive use with HENX Power Head

A40DG65B01 and Pole Saw Attachment AS-GZJ10. Never use it with other HENX attachments.

The extension pole extends the cutting range. It should to be connected between the pole saw attachment and the power head.

Follow the process in section “CONNECTING THE POLE SAW ATTACHMENT TO POWER HEAD” to install the extension pole between the pole saw attachment and power head(Figure 4).

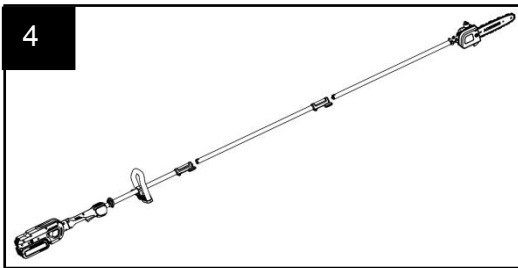

NOTICE: Once assembled correctly, the pole saw attachment, extension pole and the power head should not separate when pulled. Always test the connection by pulling on them. Repeat the steps above if the pieces can be separated.

⚠ WARNING: Failure to secure the attachment and power head/extension pole as instructed above could result in serious injury or death.

Removing the Attachment from the Power Head

1. Stop the motor and remove the battery pack.
2. Loosen the wing knob.
3. Press the shaft-release button and, with the button depressed, pull or twist the pole-saw shaft out of the coupling to separate it from the power head or the extension pole (if used).
4. Repeat the process to separate the extension pole from the power head (if extension pole is used).

OPERATION

Before each use, inspect the entire product for damaged, missing, or loose parts such as screws, nuts, bolts, caps, etc. Tighten securely all fasteners and caps and do not operate this product until all missing or damaged parts are replaced.

Applications

You may use this product for the purpose listed below:

1. Limbing
2. Pruning

Filling Oil Tank With Bar and Chain Lubricant

⚠️ WARNING: To prevent accidental starting that could cause serious personal injury; always remove the battery pack from the tool before filling the tank with oil.

⚠️ WARNING: Do not smoke or bring any fire or flame near the oil or the pole saw. Oil may spill and cause a fire.

NOTICE: The pole saw is not filled with oil at the time of purchase. It is essential to fill the tank with chain oil before use. Operating the pole saw without chain oil or when the oil level is below a certain amount will result in damage to the pole saw. Chain life and cutting capacity depend on optimum lubrication. The chain is automatically lubricated with chain oil during operation, if there is sufficient oil in the reservoir. Oil level should also be checked after every 20 minutes of use and refilled as needed.

1. Remove the battery pack from the power head.
2. Clean the oil-tank cap and the area around it to ensure that no dirt falls into the oil tank.
3. Place the pole saw attachment upright to ensure that the tank cap is facing upwards. Rotate the oil-tank cap counterclockwise to remove it.
4. Carefully pour the bar and chain oil into the tank until it fills to the tank neck. Be careful not to let the oil spill from the opening. Wipe off any excess oil.

NOTICE:

- Use bar and chain oil for best results. It is specially designed to provide low friction and faster cuts.
- Never use oil or other lubricants not specifically designed for use on the bar and chain. This can lead to a clogged oil system, which may cause premature wear of the bar and chain.
- Check the oil level frequently and refill as needed.

- Do not use dirty, used or otherwise contaminated oil. Damage may occur to the bar or chain.
- It is normal for oil to seep from the saw when it is not in use. To prevent seepage, empty the oil tank after each use, and then run the saw for one minute. When storing the tool for a long period of time, be sure the chain is lightly lubricated; this will prevent rust on the chain and bar sprocket.
- To preserve natural resources, please recycle or dispose of oil properly. Consult your local waste authority for information regarding available recycling and disposal options.

To Start/Stop the Tool

See " **STARTING/STOPPING THE POWER HEAD**" section in the power head A40DG65B01 operator's manual.

Preparation for Cutting (Fig. 5)

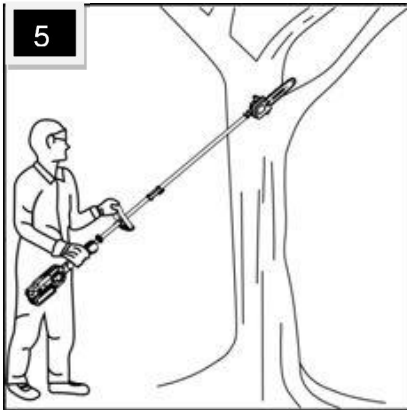

Refer to "Important Safety Instructions" earlier in this manual for appropriate safety equipment.

Make sure that the chain is properly mounted and correctly tightened.

Lift the tip of the guide bar to check for any sagging in the chain. The

chain is correctly tightened when there is no sag on the underside of the guide bar and the chain is snug, but it can be turned by hand without binding. If the tension requires adjustment, refer to the “REPLACING THE BAR AND CHAIN” section in the Maintenance section of this manual for adjustment instructions.

- Check the tension of the cover screw before use. If it is loose, securely tighten the cover screw by turning it clockwise.
- Check the tension of the cover screw before use. If it is loose, securely tighten the cover screw by turning it clockwise.
- Check the oil level and fill the tank as needed.
- Check the sharpness of the cutting teeth on the saw chain.
- Make sure the chain is well lubricated.
- Wear non-slip gloves for maximum grip and protection.
- Maintain a proper grip on the unit whenever the motor is running. Hold the unit firmly with both hands.

- Never stand directly under
- the limb you are cutting.
- Make sure that you have a secure and balanced footing. Watch out for obstacles such as tree stumps, roots and ditches, which could cause you to trip or stumble.

Basic Cutting Procedure

(Fig. 6&7)

Follow the steps below to prevent damage to tree or shrub bark. Do not use a back-and-forth sawing motion.

1. Make a shallow first cut (1/4 of the limb diameter) on the underside of the limb close to the main limb or trunk.
2. Make a second cut from the topside of the limb, outboard from the first cut. Continue the cut through the limb until the limb separates from the tree. Be prepared to balance the weight of the tool when the limb falls.
3. Make a final cut close to trunk.

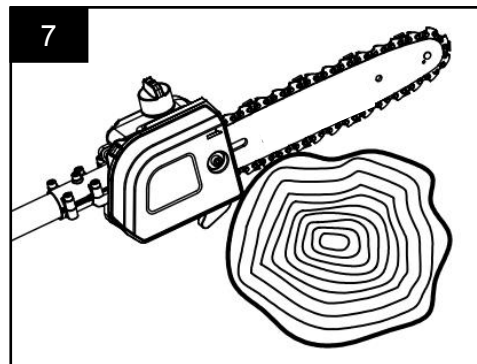
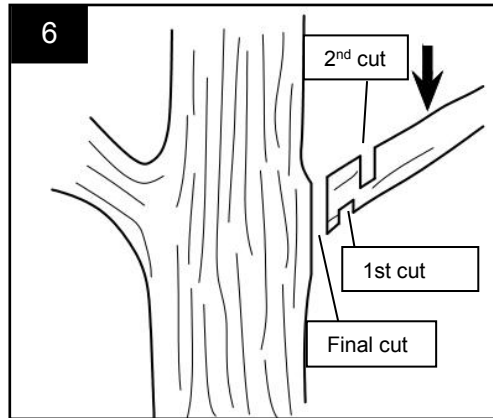

NOTICE: For second and

final cuts(from the top of the limb or branch),hold the bucking spikes against the limb being cut (Fig. F).This will help to steady the limb and make it easier to cut. Allow the chain to cut for you; exert only light downward pressure. If you force the cut, damage to the bar, chain, or motor can result.

4. Release the trigger on the power head as soon as the cut is completed.

NOTICE: Failure to follow proper cutting procedures will result in the bar and chain binding and becoming pinched or trapped in the limb. If this should happen:

- Stop the motor and remove the battery pack.
- If the limb can be reached from the ground, lift the limb while holding the saw. This should release the “pinch” and free the saw.
- If the saw is still trapped, call a professional for assistance.

Limbing and Pruning

This pole saw attachment is designed for trimming small branches and limbs up to 8" in diameter. For best results, observe the following precautions.

1. Plan the cut carefully. Be aware of the direction in which the branch will fall.

⚠ WARNING: Branches may fall in unexpected directions. Do not stand directly under the branch being cut.

2. The most typical cutting application is to position the unit at an angle of 60° or less, depending on the specific situation, as shown in Fig. 8. As the angle of the pole-saw shaft to the ground increases, the difficulty of making the first cut (from the underside of limb) increases.
3. Remove long branches in several stages.
4. Cut lower branches first to allow the top branches more room to fall.
5. Work slowly, keeping both hands on the saw with a firm grip. Maintain secure footing and balance.
6. Keep the tree between you and the chain while limbing. Cut from the side of the tree opposite the branch you are cutting.
7. Do not cut from a ladder; this is extremely dangerous. Leave such operations for professionals.
8. Do not make the flush cut next to the main limb or trunk until you have cut off much of limb to reduce the weight. Following proper cutting procedures will prevent stripping the bark from the main member.
9. Do not use the pole saw for felling or bucking.
10. To prevent electrocution, do not operate within 50ft.(15m)of overhead electrical lines(Fig. 8).
11. Keep bystanders at least 50ft.(15m) away (Fig. 8).

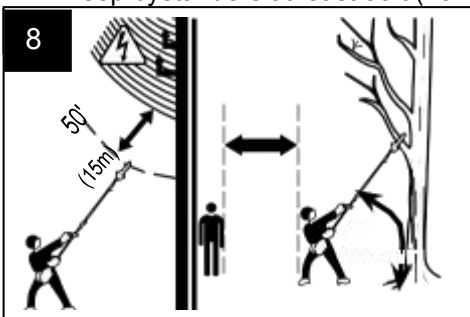

MAINTENANCE

General Maintenance

Avoid using solvents when cleaning plastic parts. Most plastics are susceptible to damage from various types of commercial solvents and may be damaged by their use. Use clean cloth to remove dirt, dust, oil, grease, etc.

Cleaning

- After each use, remove the battery and clean debris from the chain and guide bar with a soft brush. Wipe the pole saw surface with a clean cloth moistened with a mild soap solution.
- Remove the chain-sprocket cover, and then use a soft brush to remove debris from the guide bar, saw chain, sprocket and chain-sprocket cover.
- Always clean out wood chips, saw dust, and dirt from the guide bar groove when replacing the saw chain.

All pole saw service, other than the items listed in these maintenance instructions, should be performed by competent pole saw service personnel.

Replacing the Bar and Chain

⚠ WARNING: Before performing any maintenance, make sure that the battery pack is removed. Failure to heed this warning could result in serious personal injury.

⚠ WARNING: Always wear gloves when handling the bar and chain; these components are sharp and may contain burrs.

⚠ WARNING: Never touch or adjust the chain while the motor is running. The saw chain is very sharp; always wear protective gloves when performing maintenance to the chain.

NOTICE: When replacing the guide bar and chain, always use the specified bar and chain combination listed in the “**Recommended Bar and Chain for this Pole Saw**” section.

Disassembling the Worn Bar and Chain

1. Remove the battery, allow the pole saw to cool and tighten the oil-tank cap.

2. Position the pole saw attachment on its side on a firm, flat surface, so that the chain-sprocket cover is facing upwards (Fig. 9).

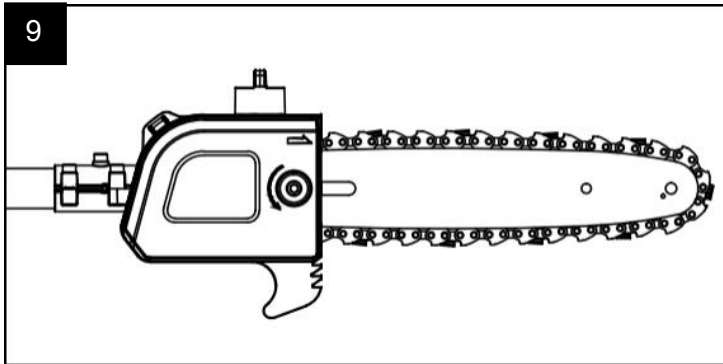

3. Wear gloves. Using the dual-head wrench provided, loosen the cover- screw assembly and remove it from the chain-sprocket cover.
4. Remove the chain-sprocket cover from the pole saw attachment. Clean the chain-sprocket cover with a dry cloth.
5. Remove the bar and chain from the mounting surface. Remove the worn chain from the bar.
6. NOTICE: If there is difficulty in removing the bar and chain from the mounting surface, place the pole saw upright, with one hand supporting the bar, and loosen the chain-tightening screw counterclockwise with the other hand. Then remove the bar with the chain.

Assembling the New Bar and Chain

1. Lay the new saw chain in a loop on a flat surface and straighten any kinks (Fig. 10).
2. Place the chain drive links into the guide-bar groove. Position the chain so there is a loop at the back of the guide bar (Fig. 11).
3. Hold the chain in position on the guide bar and place the loop around the sprocket of the pole saw

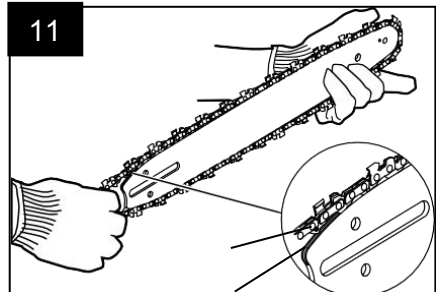
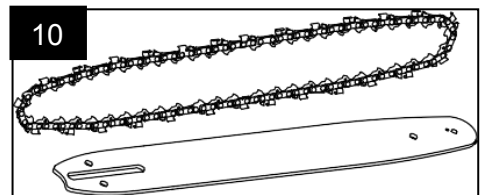

NOTICE: Small directional arrows are engraved in the saw chain. Another directional arrow is molded into the tool body(Fig.12). When looping the saw chain onto the sprocket, make sure that the direction of the arrows on the saw chain will correspond to the direction of the arrow on the tool body. If they face in opposite directions, turn over the saw chain and guide bar assembly(Fig. 13).

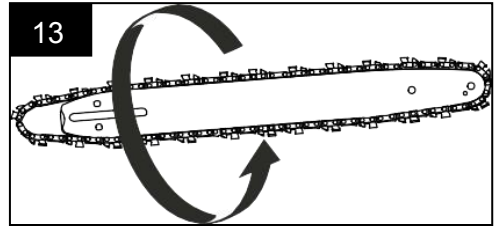
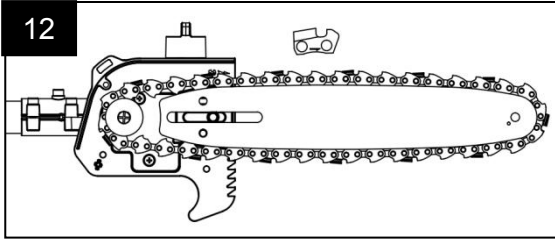

4. Place the guide bar on the mounting surface by sliding the guide-bar slot over the alignment bulges, making sure that the tension-adjusting pin is inserted in the lower hole in the tail of the bar(Fig.12).

NOTICE: If it is difficult in inserting the tension-adjusting pin into the hole, adjust the chain-tightening screw properly until the tension-adjusting pin is located exactly in the hole.

5. Replace the chain-sprocket cover, insert the cover-screw assembly through its mounting hole, and then lightly tighten the chain-sprocket cover-screw by turning it clockwise. The bar must be free to move for tension adjustment.

CAUTION: The saw chain must be properly tightened before using.

NOTICE: To extend the guide bar life, invert the bar occasionally.

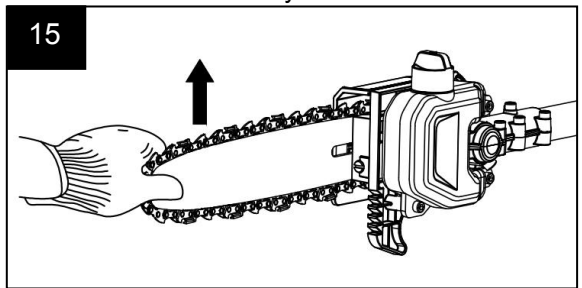
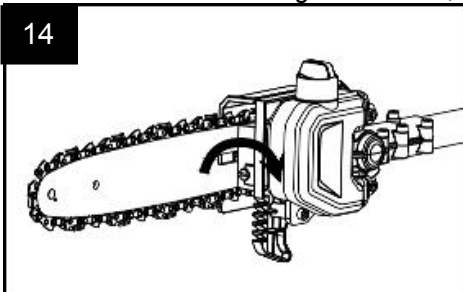

6. Remove all the slack from the chain by turning the chain-tightening screw clockwise until the chain seats snugly against the guide bar with the drive links in the guide-bar

groove (Fig. 14).

7. Lift the tip of the guide bar to check for sag (Fig. 15). Release the tip of the guide bar and turn the chain-tightening screw once clockwise. Repeat this process until the sag is eliminated.
8. Hold the tip of the guide bar up and tighten the chain-sprocket-cover screw securely. The chain is correctly tightened when there is no sag on the underside of the guide bar and the chain is snug, but it can be turned by hand without binding.

NOTICE: If the chain is too tight, it will not rotate. Loosen the chain-sprocket-cover screws lightly and turn the tightening screw 1/4 turn counter clockwise. Lift the tip of the guide bar and re-tighten the chain-sprocket-cover screw securely. Assure that the chain will rotate without binding.

Adjusting the Chain Tension

1. Stop the motor and remove the battery pack before adjusting the chain tension.
 2. Loosen the cover-screw to the point where it is finger tight.
 3. Turn the chain-tightening screw clockwise to tension the chain. See the **“REPLACING THE BAR AND CHAIN”** section in this manual for additional information.
- A cold chain is correctly tightened when there is no slack on the underside of the guide bar and the chain is snug, but it can be turned by hand without binding. The chain must be re-tightened whenever the flats on the drive links do not sit in the bar groove as Fig. 16 shown.

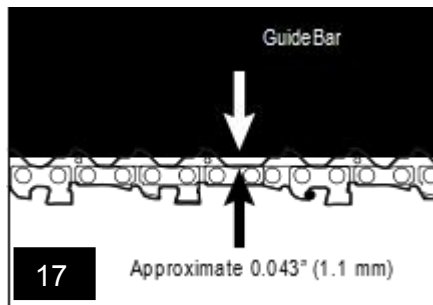
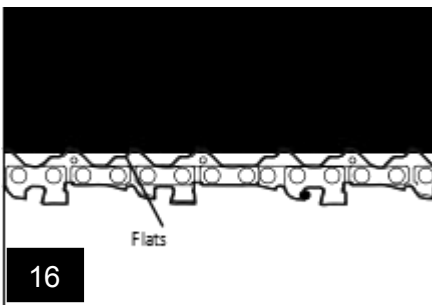

- During normal saw operation, the temperature of the chain will increase. The drive links of a correctly tightened warm chain will hang approximately 0.043in.(1.1mm)out of the bar groove(Fig. 17).

NOTICE: New chains tend to stretch; check chain tension frequently and tension as required.

NOTICE: A chain tightened while it is warm may be too tight upon cooling. Check the cold tension before next use.

Chain Maintenance

⚠ WARNING: Remove the battery pack before performing any maintenance; failure to heed this warning could result in serious personal injury.

⚠ WARNING: Always wear gloves when handling the saw chain; these components are sharp and may contain burrs.

Use only low-kickback chains on this saw. This fast cutting chain will provide kickback reduction when properly maintained.

A properly sharpened saw chain cuts through wood effortlessly, even with very little pressure.

Never use a dull or damaged saw chain. A dull saw chain cutter leads to increased physical strain, increased vibration load, unsatisfactory cutting results and increased wear.

For smooth and fast cutting, the chain needs to be maintained properly. The chain requires sharpening when the wood chips that result from cutting are small and powdery, the chain must be forced through the wood during cutting, or the chain cuts to one side. During maintenance of your chain, consider the following:

- Improper filing angle of the side plate can increase the risk of a severe kickback.
- Raker (depth gauge) clearance. Too low increases the potential for kickback. Not low enough decreases cutting ability.
- If cutter teeth have hit hard objects, such as nails and stones, or have been abraded by mud or sand on the wood, have the chain sharpened by a qualified service technician.

NOTICE:Inspectthedrivesprocketforwearordamagewhenreplacingthechain.If signs of wear or damage are present in the areas indicated, have the drive sprocket replaced by qualified service technician.

How to Sharpen the Cutters

Be careful to file all cutters(Fig. 18) to the specified angles and to the same length, as fast cutting can be obtained only when all cutters are uniform.

1. Remove the battery pack. Wear gloves for protection.
2. Properly tension the chain prior to sharpening. Refer to the “ADJUSTING THECHAIN TENSION” section earlier in this manual.

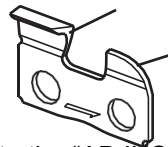

18

3. Use a 0.177" (4.5mm) diameter round file and holder (available separately). Do all of your filing at the middle position of the guide bar. (Fig. 19)

4. Keep the file level with the top plate of the tooth. Do not let the file dip or rock.

5. Keep a correct sharpening angle of 30° between the file and the saw chain; see Fig. 19 & 20. Always use a file holder (available separately) when sharpening saw chains by hand. File holder shave markings for the sharpening angle.

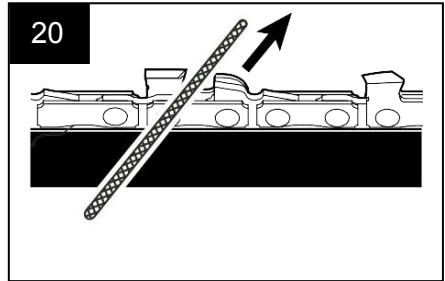
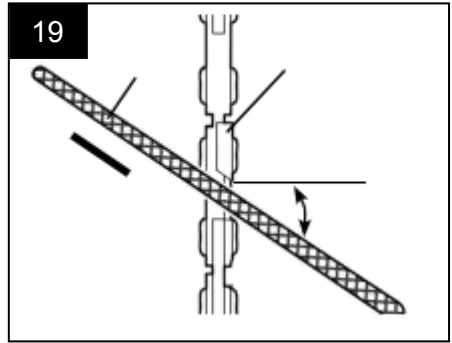

1. Using light but firm pressure,
2. stroke towards the front corner of the tooth. Lift the file away from the steel on each return stroke.
3. Make a few firm strokes on every tooth. File all left hand cutters in one direction. Then move to the other side and file the right hand cutters in the opposite direction. Occasionally remove filings from the file with a wire brush (Fig. 21).

⚠ WARNING: A dull or an improperly sharpened chain can cause excessive motor speed during cutting, which may result in severe motor damage

⚠ WARNING: Improper chain sharpening increases the potential of kickback.

⚠ WARNING: Failure to replace or repair a damaged chain can cause serious injury.

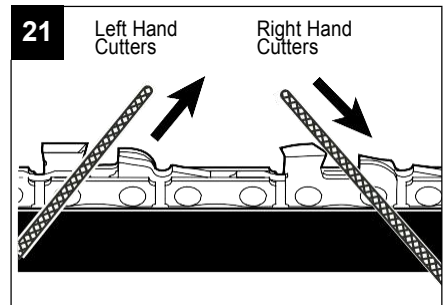

Top Plate Sharpening Angles (Fig. 22)

- **CORRECT 30°**-This optimal angle can be obtained only when the specified files and proper setting are used. File holders are marked with guide marks to align the file properly to produce the correct top plate angle.
- **LESSTHAN30°**-The tool is too dull for cutting.
- **MORETHAN30°**-The edge of the cutting tooth is feathered and dulls quickly.

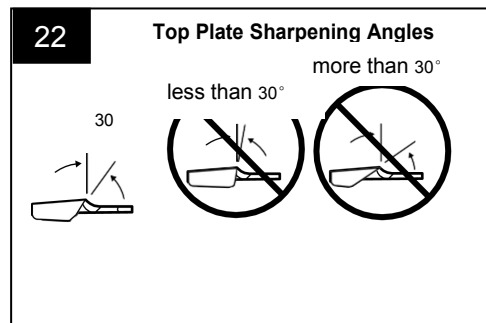

Side Plate Sharpening Angle (Fig. 23)

- **CORRECT55°**-The optimal angle can be produced automatically if the correct diameter file is used in the file holder.
- **HOOK**-“Grabs” and dulls quickly. Increases potential of KICKBACK. Results from using a file with a diameter that is too small, or a file held low.

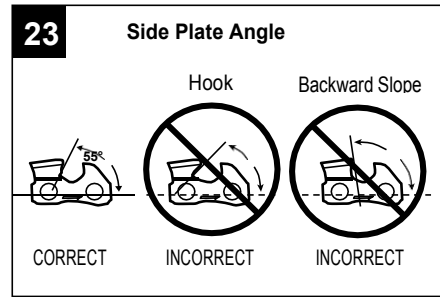

too

- **BACKWARD SLOPE**-Needs too much feed pressure, causes excessive wear to bar and chain. Results from using a file with a diameter too large, or a file held too high.

Depth Gauge Clearance

1. The depth gauge should be maintained at a clearance of 0.025 in.(0.6mm), as shown in Fig. 24. Use a depth-gauge tool (available separately)to check the depth-gauge clearances.
2. Check the depth-gauge clearance every time the chain is filed.

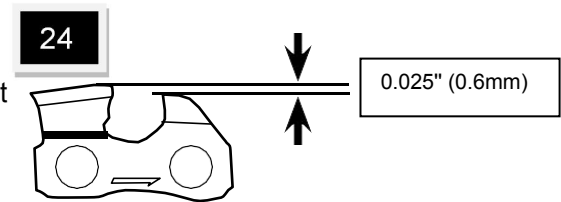

Use a flat file and a depth-gauge jointer (both available separately)to lower all gauges uniformly(Fig. 25).Depth-gauge jointers are available from 0.020in.to 0.035 in. (0.5 mm to 0.9 mm). Use a 0.25 in.(0.6 mm) depth-gauge jointer.

Depth gauges must be adjusted with the flat file in the same direction the adjoining cutter was filed with the round file. Use care not to contact the cutter face with the flat file when adjusting depth gauges.

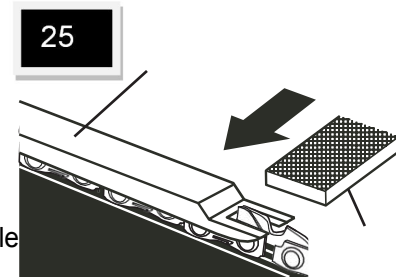

Guide Bar Maintenance

When the guide bar shows signs of wear, reverse it on the saw to distribute the wear for maximum bar life. The bar should be cleaned everyday of use and checked for wear and damage. Feathering or burring of the bar rails is a normal process of bar wear. Such faults should be smoothed with a file as soon as they occur. A bar with any of the following faults should be replaced.

- Wear inside the bar rails which permits the chain to lay over sideways.
- Bent guide bar.
- Cracked or broken rails.

- Spread rails.

In addition, the guide bar has a sprocket at its tip. The sprocket must be lubricated weekly with a grease syringe to extend the guide bar life. Use a grease syringe to lubricate weekly with chain oil by means of the lubricating hole(Fig.26).Turn the guide bar and check that the lubrication holes and chain groove are free from impurities.

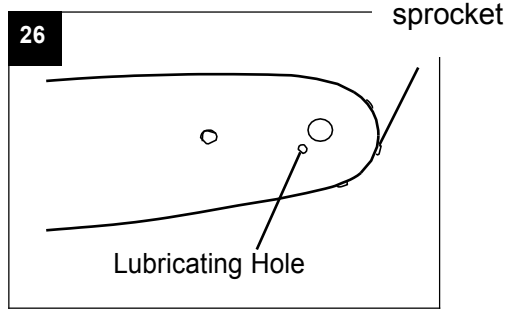

Reversing the Guide Bar

1. Remove the guide bar and chain from the pole saw, following the “REPLACING THE BAR AND CHAIN” section.
2. Remove the chain from the guide bar and turn the guide bar over (Fig. 27).The bottom of the bar will be on the top.
3. Replace the chain on the bar.
4. Reassemble the guide bar and chain on the pole saw and adjust the chain tension, following the“ REPLACING THE BAR AND CHAIN” and “ADJUSTING THE CHAIN TENSION” sections.

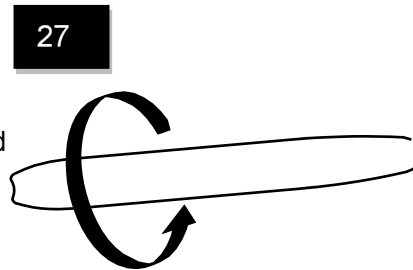

Transmission Gears Lubrication

The transmission gears in the gear case need be lubricated periodically with gear grease. Check the gear case grease level about every 50hours of operation by removing the sealing screw on the side of the case.

If no grease can be seen on the sides of the gear, follow the steps below to fill with gear grease up to3/4 capacity.

Do not completely fill the transmission gear case.

1. Position the pole saw attachment on its chain-sprocket cover side on a firm, flat surface, so that the sealing screw is facing upwards(Fig. 28).
2. Use the dual-head wrench provided to loosen and remove the injection screw.

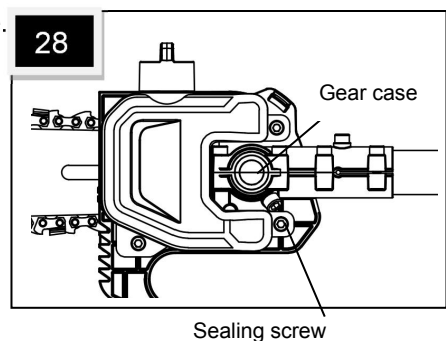

3. Use a grease syringe(not included) to inject some grease into the screw hole, taking care not to exceed 3/4 capacity.
4. Tighten the sealing screw after injection.

TROUBLESHOOTING

PROBLEM	CAUSE	SOLUTION
<p>Motor does not run.</p>	<ul style="list-style-type: none"> ▪ The battery pack is not attached to the pole saw. ▪ No electrical contact between the saw and battery. ▪ The battery pack is depleted. ▪ The lock-off button is not depressed before pressing the trigger. ▪ The battery pack or power head is too hot. ▪ Saw chain is bound in the wood. ▪ Debris in bar groove. ▪ Debris in chain-sprocket cover. 	<ul style="list-style-type: none"> ▪ Attach the battery pack to the pole saw. ▪ Remove battery, check contacts and re-install the battery pack. ▪ Charge the battery pack. ▪ Press down the lock-off lever and hold it, then depress the trigger to turn on the pole saw. ▪ Allow the battery pack or power head to cool until the temperature drops below 152°F (67°C). ▪ Release the trigger; remove the saw chain and guide bar from the wood, then restart the pole saw. ▪ Press the saw chain against the wood, move the pole saw back and forth to discharge the debris. ▪ Remove battery pack, then remove chain-sprocket cover and clean out debris.
<p>Motor runs, but chain does not rotate.</p>	<ul style="list-style-type: none"> ▪ Chain does not engage drive sprocket. 	<ul style="list-style-type: none"> ▪ Remove the battery pack and re-install the chain, making sure that the drive links on the chain are fully seated on the sprocket.

<p>Pole saw does not cut properly.</p>	<ul style="list-style-type: none"> ▪ Insufficient chain tension. ▪ Dull chain. ▪ Chain installed backwards. ▪ Worn chain. ▪ Dry or excessively stretched chain. ▪ Chain not in bar groove. 	<ul style="list-style-type: none"> ▪ Remove the battery pack and readjust the chain tension, following the section “ADJUSTING THE CHAIN TENSION”. ▪ Sharpen the chain cutters, following the section “How to Sharpen the Cutters”. ▪ Remove the battery pack and re-install the saw chain, following the section “REPLACING THE BAR ANDCHAIN”. ▪ Remove the battery pack and replace the chain following the section “REPLACING THE BAR ANDCHAIN”. ▪ Check the oil level. Refill the oil tank if necessary. ▪ Remove the battery pack and re-install the saw chain, following the section “REPLACING THE BAR ANDCHAIN”.
<p>Bar and chain running hot and smoking.</p>	<ul style="list-style-type: none"> ▪ Check chain tension for over-tightened condition. ▪ Chain oil tank is empty. ▪ Debris in guide bar groove. 	<ul style="list-style-type: none"> ▪ Remove the battery pack and re-tension the saw chain; see the section “ADJUSTING THE CHAIN TENSION”. ▪ Filling bar and chain lubricant. ▪ Clear the debris in the groove.

LINE TRIMMER/BRUSH CUTTER ATTACHMENT

SPECIFICATION

Cutting Mechanism	Bump Head
Line Diameter	3-teeth blade
Cutting Width of trimmer	35 cm
Cutting width of brush cutter	25.4cm
Weight (Without battery pack)	1.42kg

- The declared vibration total value has been measured in accordance with a standard test method and may be used for comparing one tool with another;
- The declared vibration total value may also be used in a preliminary assessment of exposure.

PACKING LIST

About recommended cutting line, please refer to the HEXN Product Catalogue

PART NAME	QUANTITY
Line Trimmer Attachment	1
Guard	1
Hex Wrench	1
Multifunctional Wrench	1
Operator's Manual	1

DESCRIPTION

Refer to Fig. 29 for different parts of line trimmer/brush cutter as follows.

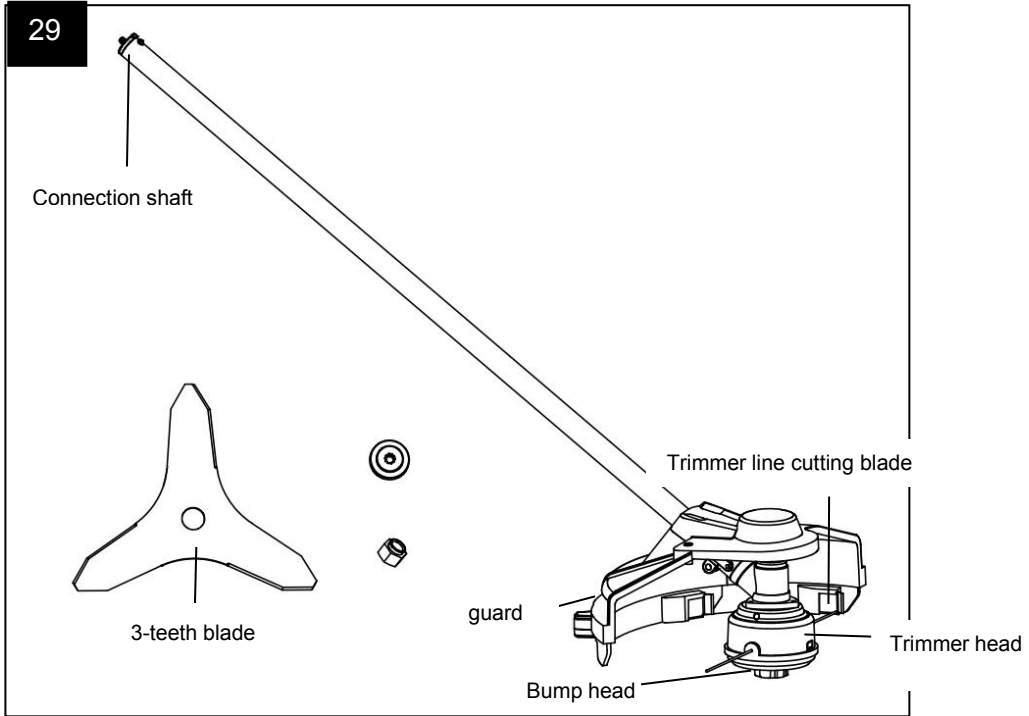

WARNING: If any parts are damaged or missing, do not operate this product until the parts are replaced. Use of this product with damaged or missing parts could result in serious personal injury.

⚠ WARNING: Do not attempt to modify this product or create accessories not recommended for use with this line trimmer/brush cutter. Any such alteration or modification is misuse and could result in a hazardous condition leading to possibly serious personal injury.

⚠ WARNING: Do not connect to power head until assembly is complete. Failure to comply could result in accidental starting and possible serious personal injury.

Mounting the Guard

⚠ WARNING: Always wear gloves when mounting or replacing the guard. Be careful of the blade on the guard and protect your hands from being injured by the blade.

1. Place the guard under the aluminum shaft while place the guard upper housing above the aluminum shaft. Keep 2 holes on the guard, 2 holes on the guard upper housing and 2 holes on locking clamp the same line, insert hex screws on 2 holes and tighten them. After that, tighten 3 tapping screws.

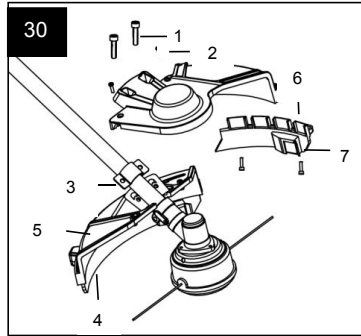

1. hex screw 2. tapping screw 3. locking clamp 4. guard 5. guard upper housing 6. upper housing decoration strip 7. cutting blade 8. tapping screw

2. Insert upper housing decoration strip into the guard upper housing and then tighten it with hex screw (Fig. 31).

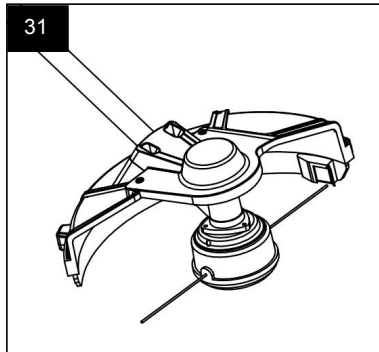

Connecting the Line Trimmer Attachment to the Power Head

This line trimmer attachment is designed for use with HENX Power Head A40DG65B01.

See “INSTALLING AN ATTACHMENT TO THE POWER HEAD” section in the power head A40DG65B01 operator’s manual.

Adjusting Cutting Line Length (Fig. 32).

The trimmer head allows the operator to release more cutting line without stopping the motor. As line becomes frayed or worn, additional line can be released by lightly tapping the trimmer head on the ground while operating the trimmer (Fig. 32).

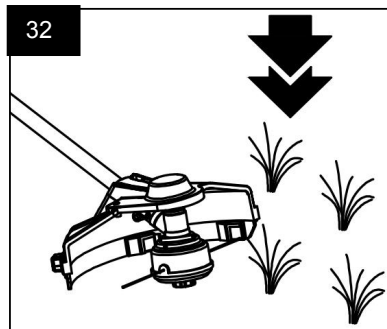

⚠ WARNING: Do not remove or alter the line-cutting blade assembly. Excessive line length will cause the motor to overheat and may result in serious personal injury.

For the best performance, knock the trimmer head on naked ground or hard soil. The motor will become overheated if you release trimmer line on ground with long grass. Always keep the trimmer line at the full length. Line release will become more difficult as the cutting line becomes shorter.

Reload the trimmer line if necessary (Fig 33, Fig 34 & Fig 35)

Note: When the cutting line breaks from the line outlet or the cutting line is not released when tapping the trimmer head, you should remove the remain cutting line from the spool retainer and install the cutting line by following the steps below:

1. Remove the battery pack.
2. Rotate the bump head on the trimmer head until the arrow on the bump head aligns with the arrow on trimmer head housing.
3. Insert the line into the mounting hole inside the eyelet. Push and pull the line from the other side until equal amounts of line appear on both sides of the spool.
4. Rotate the bump head clockwise after line insertion until all trimmer line are well winded (only 350mm trimmer line will be left as cutting diameter.)

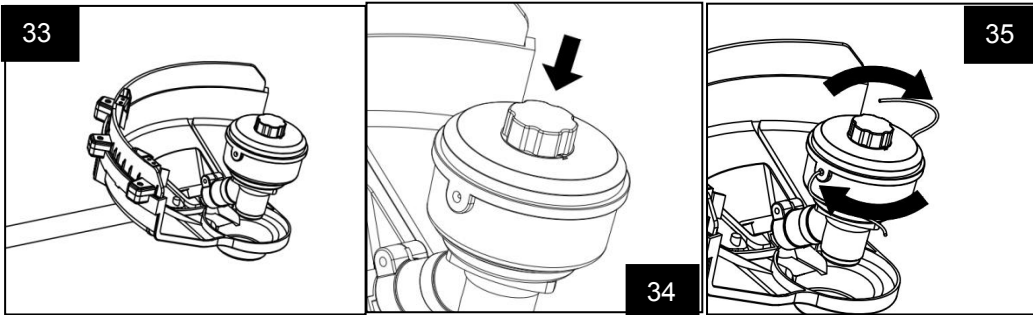

3-teeth Blade Replacement (Fig. 36 and Fig. 37)

When using this machine in bushes or reeds, the trimmer head shall be replaced with 3-teeth blade by following the steps below.

Insert steel rod into bump head/blade mounting hole so that motor will stop run. Hold and rotate the trimmer head in clockwise and take it out. Pre-install the manufacturer recommended 3-teeth blade on blade cover plate, align the hole on 3-teeth blade with bulge on blade cover plate and then install the blade cover plate, tighten the square head nut with slotted screw drive.

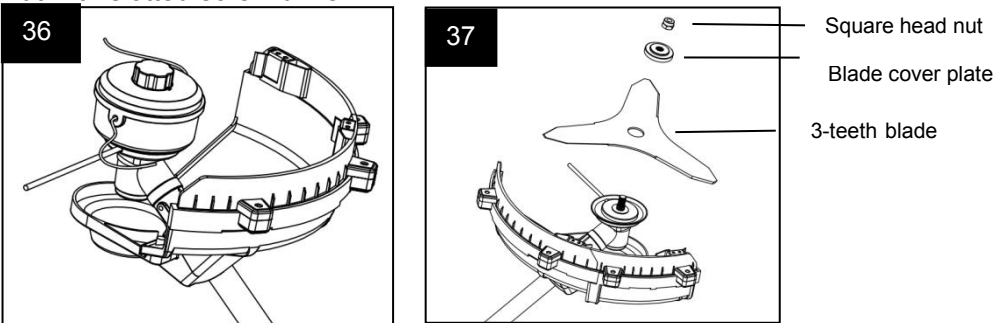

Sharpen the Line-cutting Blade

⚠️ WARNING: Always protect your hands by wearing heavy gloves when performing any maintenance on the line-cutting blade.

1. Remove the line-cutting blade from the guard.
2. Secure the blade in a vise.
3. Wear proper eye protection and gloves and be careful not to cut yourself.
4. Carefully file the cutting edges of the blade with a fine-tooth file or sharpening stone, maintaining the original cutting edge angle.
5. Replace the blade on the guard and secure it in place with the two screws.

OPERATION

⚠️ WARNING: Do not allow familiarity with this product to make you careless. Remember that a careless fraction of a second is sufficient to inflict serious injury.

⚠️ WARNING: Always wear eye protection with side shields marked to comply with ANSI Z87.1, along with hearing protection. Failure to do so could result in objects being thrown into your eyes and other possible serious injuries.

Application

You may use this product for the purpose listed below:

Trimming grass and weeds from around porches, fences, and decks.

NOTICE: The tool is to be used only for its prescribed purpose. Any other use is deemed to be a case of misuse.

Check for Damaged/Worn Parts before Each Use

Check the trimmer head, guard and front-assist handle and replace any parts that are cracked, warped, bent, or damaged in any way.

The line-cutting blade on the edge of the guard can dull over time. It is recommended that you periodically sharp- en it with a file or replace it with a new blade.

⚠️ WARNING: Always wear gloves when mounting or replacing the guard. Be careful of the blade on the guard and protect your hands from being injured by the blade.

⚠️ WARNING: To prevent serious personal injury, remove the battery pack from the power head before servicing, cleaning, changing attachments or removing material from the unit.

⚠️ WARNING: Dress properly to reduce the risk of injury when operating this tool. Do not wear loose clothing or jewelry. Wear eye and ear/hearing protection. Wear heavy,

long pants, boots and gloves. Do not wear short pants or sandals or go barefoot.

▲ WARNING: Clear the area to be cut before each use. Remove all objects, such as rocks, broken glass, nails, wire, or string that can be thrown or become entangled in the cutting attachment. Clear the area of children, bystanders, and pets. At a minimum, keep all children, bystanders and pets at least 15m away; there still may be risk to bystanders from thrown objects. Bystanders should be encouraged to wear eye protection. If you are approached, stop the motor and cutting attachment immediately.

For safe and better operation, put on the shoulder strap across the shoulder. Adjust the shoulder strap in a comfortable operating position. Hold the line trimmer with your one hand on the rear handle and your other hand on the front-assist handle. Keep a firm grip with both hands while in operation. The line trimmer should be held at a comfortable position with the rear handle about hip height. The trimmer head should be parallel to the ground such that it easily contacts the material to be cut without the operator having to bend over.

▲ WARNING: The shoulder strap is also a quick release mechanism in hazardous situation. When emergency occurs, take it off from your shoulder immediately, no matter what way the strap is in.

MAINTENANCE

▲ WARNING: Before inspecting, cleaning or servicing the unit, stop the motor, wait for all moving parts to stop, and remove the battery pack. Failure to follow these instructions can result in serious personal injury or property damage.

▲ WARNING: When servicing, use only identical replacement parts. Use of any other parts can create a hazard or cause product damage. To ensure safety and reliability, all repairs, other than the items listed in these maintenance instructions, should be performed by a qualified service technician.

General Maintenance

Avoid using solvents when cleaning plastic parts. Most plastics are susceptible to damage from various types of commercial solvents and may be damaged by their use. Use clean cloth to remove dirt, dust, oil, grease, etc.

CLEAN THE UNIT

- Clear any grass that may have wrapped itself around the motor shaft or trimmer head.
- Use a small brush or a small vacuum cleaner to clean the air vents on the rear housing.
- Keep the vent free from block.
- Clean the unit using a damp cloth with a mild detergent.
- Do not use any strong detergents on the plastic housing or the handle. They can be damaged by certain aromatic oils, such as pine and lemon, and by solvents such as kerosene. Moisture can also cause a shock hazard. Wipe off any moisture with a soft dry cloth.

Transmission Gears Lubrication

The transmission gears in the gear case need be lubricated periodically with gear grease. Check the gear case grease level about every 50 hours of operation by removing the sealing screw on the side of the case.

If no grease can be seen on the flanks of the gear, follow the steps below to fill with gear grease up to 3/4 capacity.

Do not completely fill the transmission gears.

Hold the line trimmer on its side so that the sealing screw is facing upwards (Fig. M).

Use the multifunctional wrench provided to loosen and remove the sealing screw.

Use a grease syringe (not included) to inject some grease into the screw hole; do not exceed 3/4 capacity.

Tighten the sealing screw after injection.

Storing the Unit

- Remove the battery pack from the trimmer.
- Clean the tool thoroughly before storing it.
- If the line trimmer attachment is removed from the power head and stored separately: Fit the end cap on the attachment shaft to avoid dirt getting into the coupling.
- Store the unit in a dry, well-ventilated area, locked-up or up high, out of the reach of children. Do not store the unit on or adjacent to fertilizers, gasoline, or other chemicals.

WARRANTY

HENX WARRANTY

2 year warranty on HENX outdoor power equipment and 2 year warranty on HENX battery packs and chargers.

Please contact HENX Customer Service Toll-Free at (866)678-8989 any time you have questions or warranty claims.

LIMITED SERVICE WARRANTY

FOR 2YEARS from the date of original retail purchase, this HENX product is warranted against defects in material or workmanship. Defective product will receive free repair.

FOR TWO YEARS from the date of original retail purchase, the HENX battery packs and charger are warranted against defects in material or workmanship.

Defective product will receive free repair.

This warranty does not cover routine maintenance parts and consumables that can wear out from normal use within the warranty period.

This warranty applies only to the original purchaser at retail and may not be transferred.

The warranty period for any HENX product or part used for industrial, professional or commercial purpose is one year.

This warranty is void if the product has been used for rental purpose.

This warranty does not cover the damage resulting from modification, alteration or unauthorized repair.

This warranty only covers defects arising under normal usage and does not cover any malfun

ction, failure or defect resulting from misuse, abuse(including overloading of the product beyond capacity and exposure to water or rain), accidents, neglect or lack of proper installation, and improper maintenance or storage.

This warranty does not cover normal deterioration of the exterior finish, including but not limited to scratches, dents,paint chips, or to any corrosion or discoloring by heat, abrasive and chemical cleaners.

HOW TO OBTAIN SERVICE

For warranty service, please contact HENX customer service at (866)678-8989. When requesting warranty service, you must present the original dated sales receipt. An authorized service center will be selected to repair the product according to the stated warranty terms.

ADDITIONAL LIMITATIONS

To the extent permitted by applicable law, all implied warranties, including warranties of MERCHANTABILITY or FITNESS FOR A PARTICULAR PURPOSE, are disclaimed. Any implied warranties, including warranties of merchantability or fitness for a particular purpose, that cannot be disclaimed under state law are limited to three years from the date of purchase for outdoor power equipment and two years from date of purchase for battery pack and charger. Some states do not allow limitations on how long an implied warranty lasts and/or do not allow the exclusion or limitation of incidental or consequential damages, so the above limitations may not apply to you.

This warranty gives you specific legal rights, and you may also have other rights which vary from state to state.

For customer service contact us at: (866)-678-8989 or www.henxpower.com HENX customer service.



Bring Power to Your Garden.

www.henxpower.com