

# INSTRUCTION MANUAL

AIR06-A

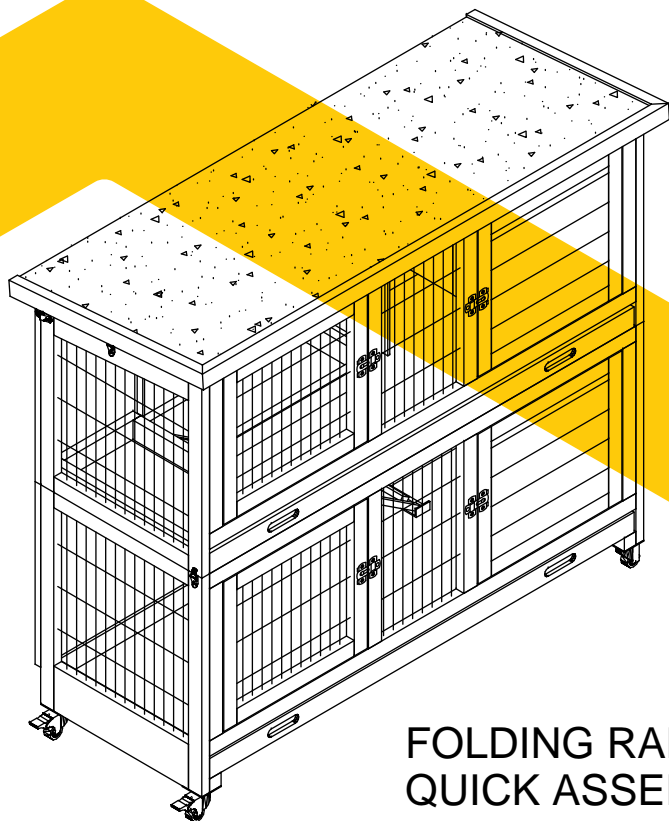

FOLDING RABBIT HUTCH  
QUICK ASSEMBLY





## NOTICE

Please retain these instructions for future reference.

- Firmly secure all bolts,screws and knobs before use.
- Reconfirm that all bolts,screws,and knobs are secure every 90 days.
- Fasten screws loosely during initial assembly. Do not fully tighten screws until the item is completely assembled.
- Do not use or store this item in the proximity of open flame or flammable/combustible chemicals.
- Be aware that some parts are heavy and have sharp edges.
- Be aware that moving parts can injure,crush and cut.
- If any parts are missing,broken,damaged,or worn,stop using this product until repairs are made and/or factory replacement parts are installed.
- Do not use this item in a way inconsistent with the manufacturer's instructions as this could void the product warranty.

## TOOLS REQUIRED //



PHILLIPS  
SCREWDRIVER

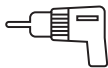

DRILL  
(RECOMMENDED)



2PERSON  
ASSEMBLY



APPROXIMATELY  
15MIN. ASSEMBLY

## HARDWARE //

M3.0x25mm SCREW  
16PCS+1 spare



P1

M3.0x14mm SCREW  
4PCS+1 spare



P2

Screw Gasket  
16PCS+1 spare



P3

# PARTS

Foldable Front Panel -  
Down  
1PC

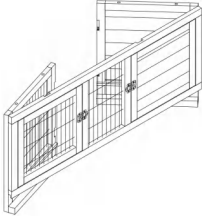

**A**

Brake Casters  
2PCS

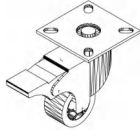

**B**

Casters Without Brake  
2PCS

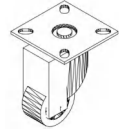

**C**

Foldable Back Panel  
1PC

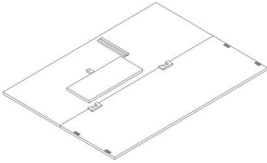

**D**

Metal Ramp Supporting  
1PC

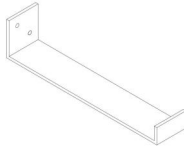

**E**

Foldable Front Panel -  
Upper  
1PC

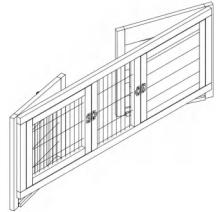

**F**

Tray Supporting Bars  
2PCS

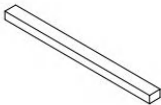

**G**

Ramp  
1PC

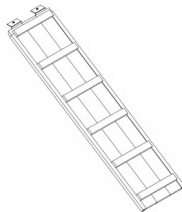

**H**

Divider  
1PC

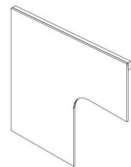

**I**

# PARTS

Bottom Tray  
1PC

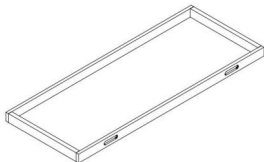

J

Middle Tray  
1PC

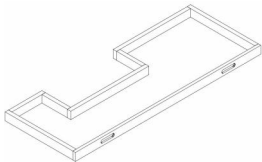

K

Roof  
1PC

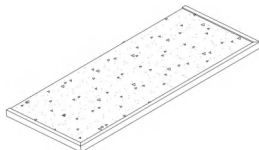

L

# PRODUCT ASSEMBLY //

## 01

Expand the Part A .

Screw two brake casters Part B to the left of hutch legs from bottom by P1x4 screws with P3x4 screw gasket.(notice the casters position is 15mm from edge).  
Screw two casters without brake Part C to the right of hutch legs from bottom by P1x4 screws with P3x4 screw gasket.(notice: the casters position is 15mm from edge).

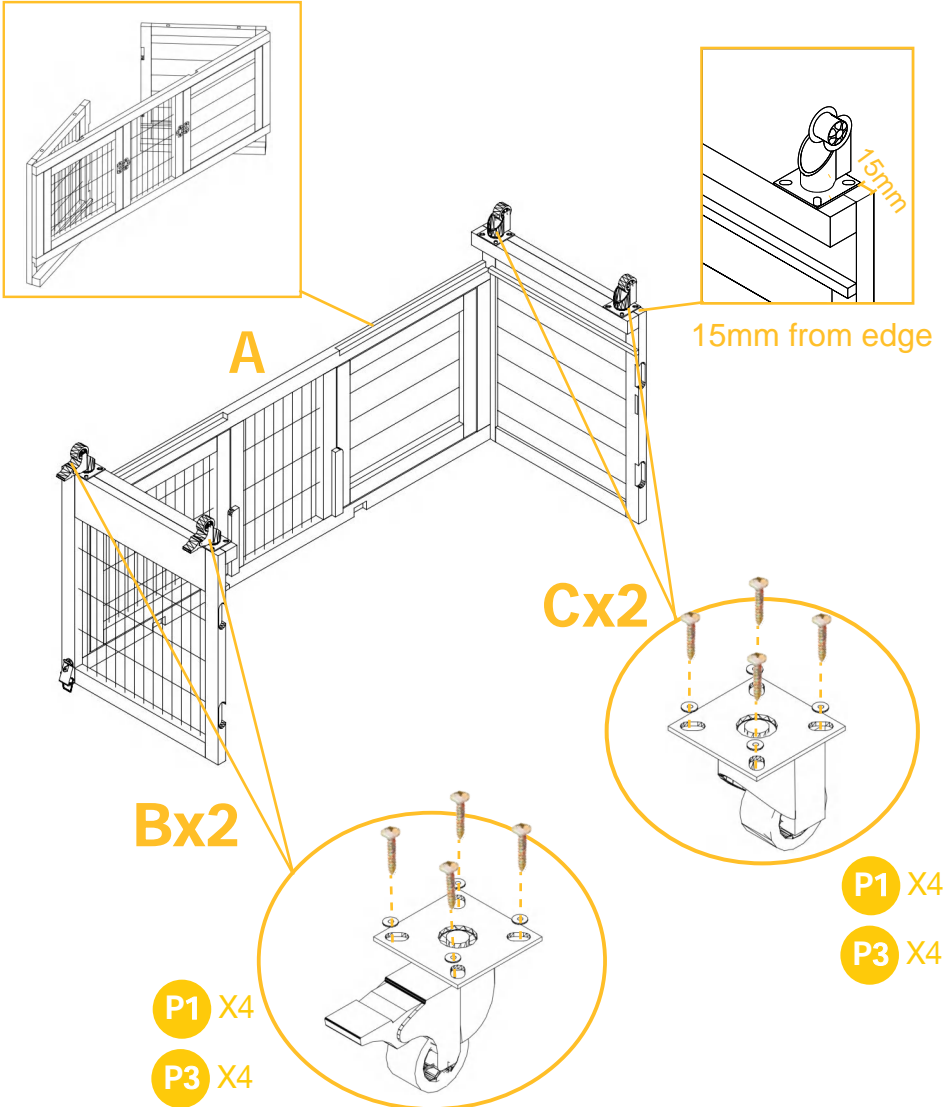

## PRODUCT ASSEMBLY //

**02** Screw the metal ramp support Part E to the back panel Part D by P2x2 screws according to the predrill holes.

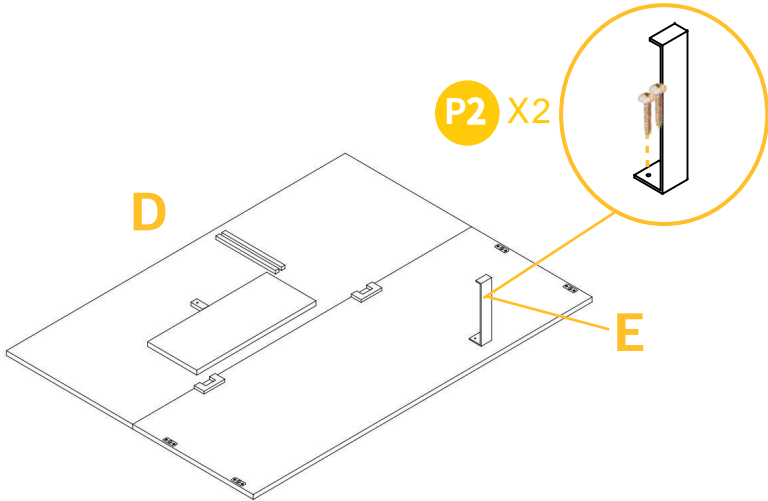

**03** Attach the foldable Back Panel Part D to the Part A by 2 buckles on each side.

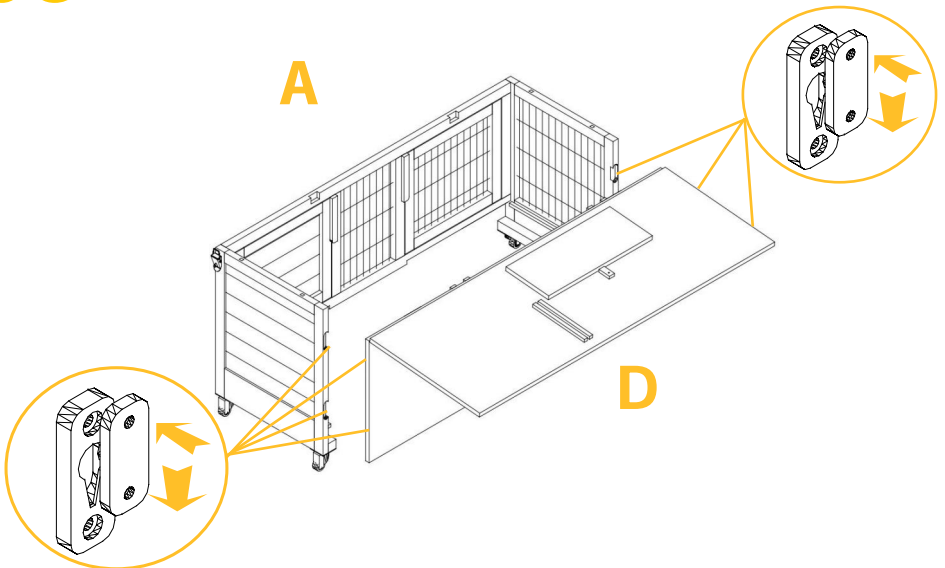



## PRODUCT ASSEMBLY //

**04** Put down tray supporting bars 2pcs of Part G.

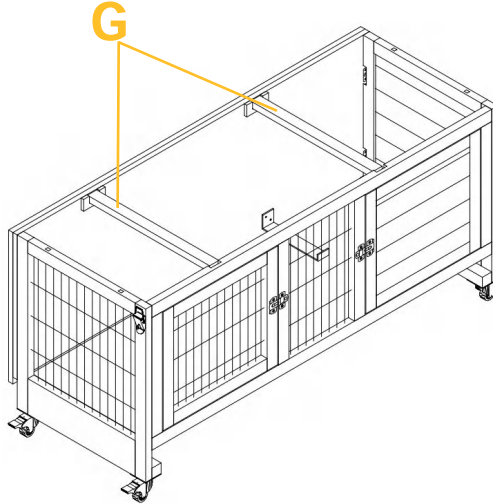

**05** Screw the ramp Part H to the supporting bars by P2x2.

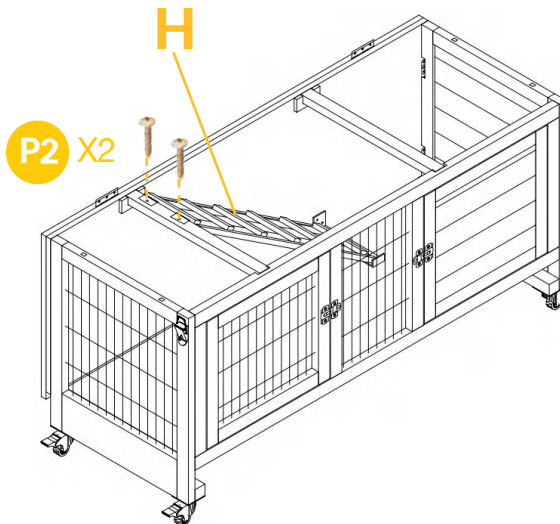

## PRODUCT ASSEMBLY //

**06** Attach the upper & down front panel Part F & Part A with Wooden cork and one buckles each side.

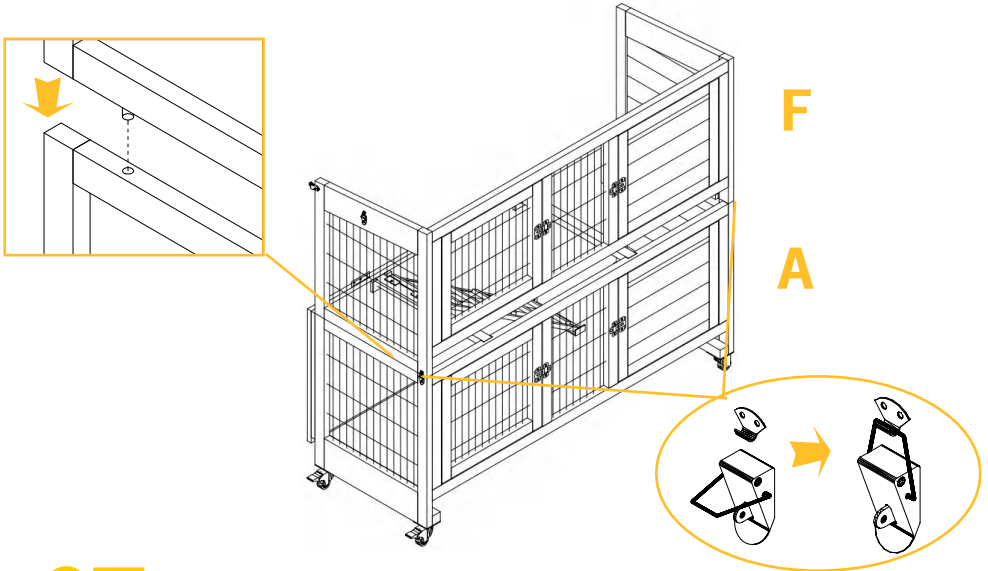

**07** Attach the upper front panel Part F and back panel Part D by one buckles each side.

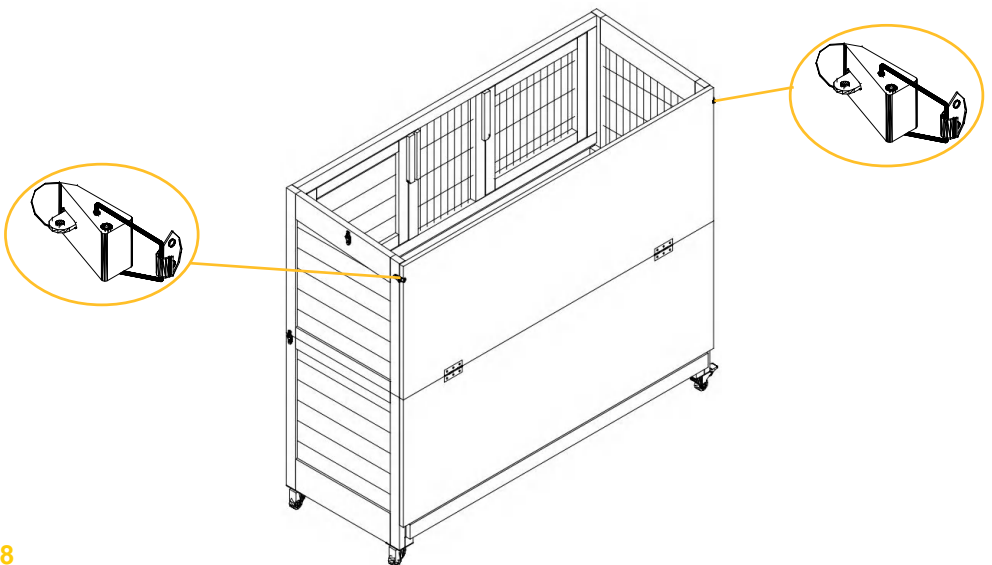

## PRODUCT ASSEMBLY //

08

Put in the divider Part I as show on picture.  
Slide in the bottom tray Part J and middle tray Part K.

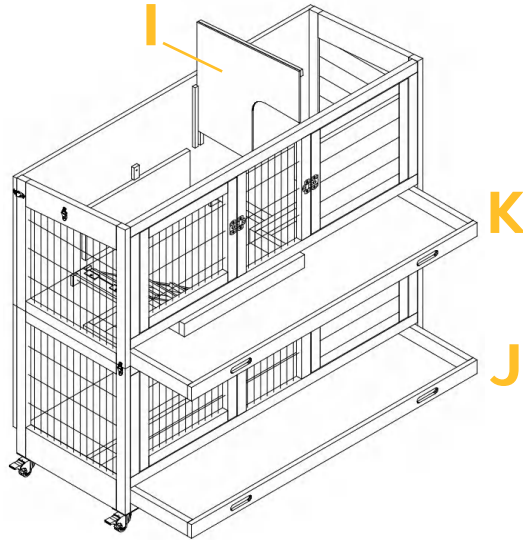

09

Attach the roof Part L by one buckles each side.

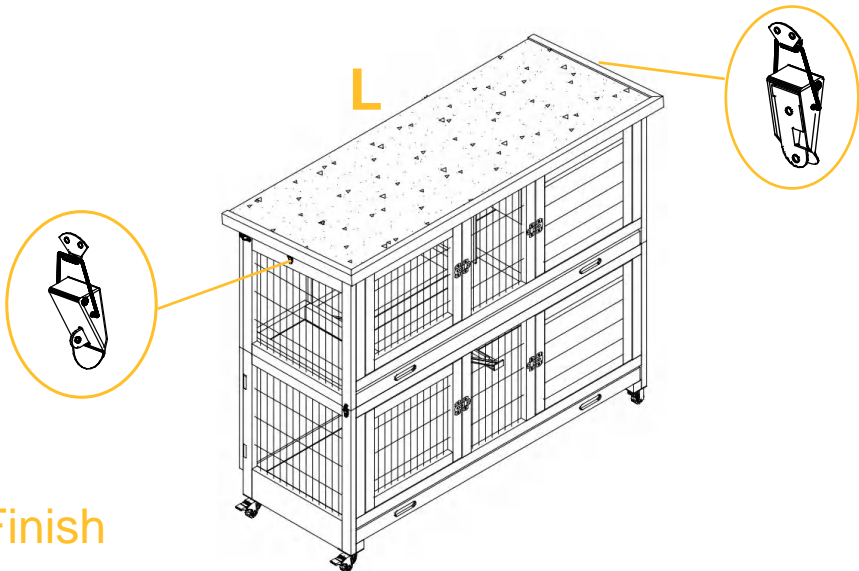

Finish



**WARNING**

Manufacturer and seller expressly disclaim any and all liability for personal injury, property damage or loss, whether direct, indirect, or incidental, resulting from the incorrect attachment, improper use, inadequate maintenance, or neglect of this product.