

PRORUN[®]

60V /// *Lithium-Ion*

Operator's Manual

CORDLESS CHAINSAW

MODEL: PCS160H

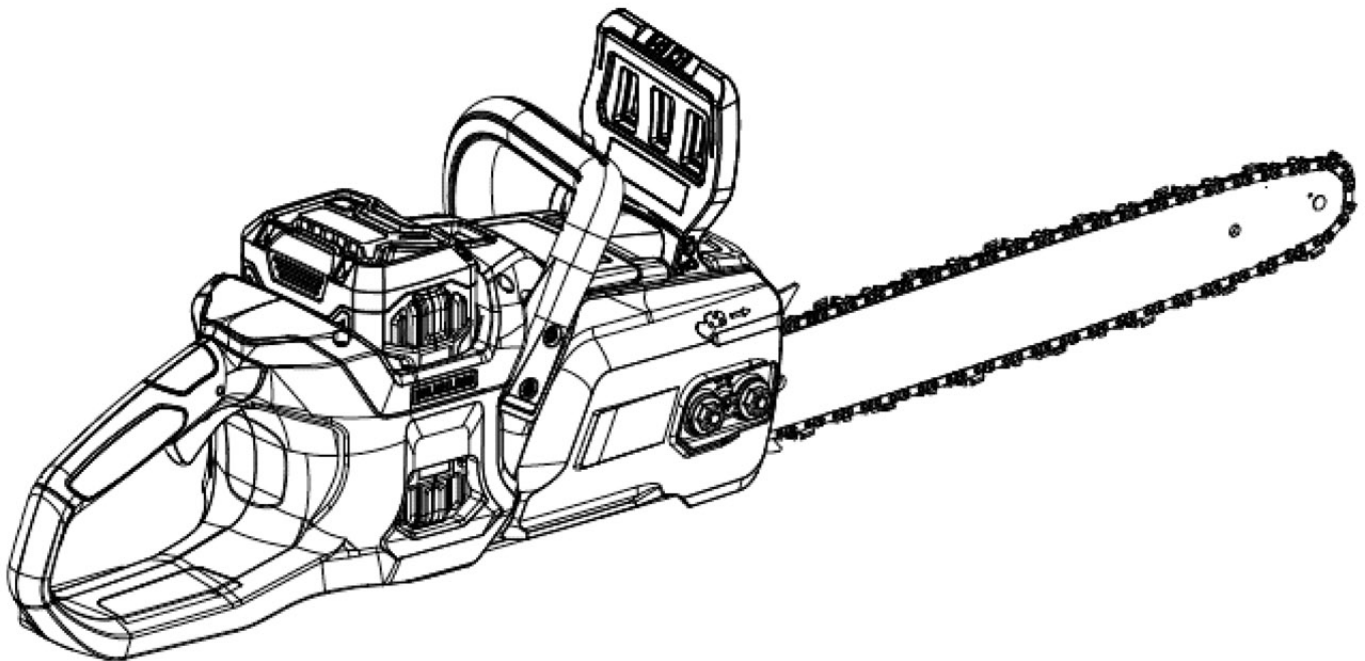

Before charging, read the instructions.

⚠ IMPORTANT - READ CAREFULLY BEFORE USE

⚠ IMPORTANT SAFETY INSTRUCTIONS - SAVE THESE INSTRUCTIONS



WARNING: To reduce the risk of injury, the user must read and understand the Operator's Manual before using this product. Save these instructions for future reference.

Please let us know what you think.
To leave a review and see our full line of products, visit:

proruntech.com ★ ★ ★ ★ ★
1-844-905-0882, info@proruntech.com

Table of Contents

1. GENERAL MACHINE SAFETY WARNINGS	1
2. SAFETY INSTRUCTIONS FOR CHAINSAW	3
3. TRANSPORTATION AND STORAGE	5
4. BATTERY AND BATTERY CHARGER	6
5. SYMBOLS	8
6. SPECIFICATIONS	10
7. KNOW YOUR CHAINSAW	11
8. BATTERY AND CHARGER OPERATION	12
9. ASSEMBLY INSTRUCTIONS	15
10. OPERATION	17
11. MAINTENANCE AND REPAIR	23
12. TRANSPORTING, CLEANING, AND STORING	25
13. TROUBLESHOOTING	26
14. DISPOSAL	27
15. EXPLODED VIEW	28
16. EC DECLARATION	31

1. GENERAL MACHINE SAFETY WARNINGS

⚠ WARNING! Read all safety warnings, instructions, illustrations, and specifications provided with this machine. *Failure to follow the warnings and instructions may result in electric shock, fire, and/or serious injuries.*

Save all warnings and instructions for future reference.

The term “machine” in all of the warnings listed below refers to your battery operated (cordless) machine.

● Work area safety

a) Keep work area clean and well lit. *Cluttered or dark areas invite accidents.*

b) Do not operate machines in explosive atmospheres, such as in the presence of flammable liquids, gases, or dust. *Machines create sparks which may ignite the dust or fumes.*

c) Keep children and bystanders away while operating a machine. *Distractions can cause you to lose control.*

● Electrical safety

a) Avoid body contact with earthed or grounded surfaces such as pipes, radiators, ranges, and refrigerators. *There is an increased risk of electric shock if your body is earthed or grounded.*

b) Do not expose machines to rain or wet conditions. *Water entering a machine will increase the risk of electric shock.*

c) Do not abuse the battery charger cord. Never use the cord for carrying.

Keep cord away from heat, oil, sharp edges, or moving parts. Damaged or entangled cords increase the risk of electric shock.

● Personal safety

a) Stay alert, watch what you are doing, and use common sense when operating a machine. Do not use a machine while you are tired or under the influence of drugs, alcohol, or medication. *A moment of inattention while operating machines may result in serious personal injury.*

b) Use personal protective equipment. Always wear eye protection. *Protective equipment such as dust mask, non-skid safety shoes, hard hat, or hearing protection used for appropriate conditions will reduce personal injuries.*

c) Prevent unintentional starting. Ensure the switch is in the off position before connecting battery pack and/or to power source, picking up or carrying the machine. *Carrying machines with your finger on the switch or energizing machines that have the switch on invites accidents.*

d) Remove any adjusting key or wrench before turning the machine on. *A wrench or a key left attached to a moving part of*

machine may result in personal injury.

e) Do not overreach. Keep proper footing and balance at all times. *This enables better control of the machine in unexpected situations.*

f) Dress properly. Do not wear loose clothing or jewelry. Keep your hair, clothing, and gloves away from moving parts. *Loose clothes, jewelry, or long hair can be caught in moving parts.*

g) If devices are provided for the connection of dust extraction and collection facilities, ensure these are connected and properly used. *Use of these devices can reduce dust-related hazards.*

h) Do not let familiarity gained from frequent use of tools allow you to become complacent and ignore tool safety principles. *A careless action can cause severe injury within a fraction of a second.*

● **Machine use and care**

a) Do not force the machine. Use the correct machine for your application. *The correct machine will do the job better and safer at the rate for which it was designed.*

b) Do not use the machine if the switch does not turn it on and off. *Any machine that cannot be controlled with the switch is dangerous and must be repaired.*

c) Remove the battery pack from the machine before making any adjustments, changing accessories, or storing machines. *Such preventive safety measures reduce the risk of starting the power tool accidentally.*

d) Store idle machines out of the reach of children and do not allow persons unfamiliar with the machine or these instructions to operate the machine. *Machines are dangerous in the hands of untrained users.*

e) Maintain machines and accessories. Check for misalignment or binding of moving parts, breakage of parts, and any other condition that may affect the machine's operation. If damaged, have the machine repaired before use. *Many accidents are caused by poorly maintained machines.*

f) Keep cutting tools sharp and clean. *Properly maintained cutting tools with sharp cutting edges are less likely to bind and are easier to control.*

g) Use the machine, accessories, and tool bits etc. in accordance with these instructions, taking into account the working conditions and the work to be performed. *Use of the machine for operations different from those intended could result in a hazardous situation.*

h) Keep handles and grasping surfaces dry, clean, and free

from oil and grease. Slippery handles and grasping surfaces do not allow for safe handling and control of the tool in unexpected situations.

● **Battery tool use and care**

a) **Recharge only with the charger specified by the manufacturer.** A charger that is suitable for one type of battery pack may create a risk of fire when used with another battery pack.

b) **Use machines only with specifically designated battery packs.** Use of any other battery packs may create a risk of injury and fire.

c) **When battery pack is not in use, keep it away from other metal objects, like paper clips, coins, keys, nails, screws, or other small metal objects, which can make a connection from one terminal to another.** Shorting the battery terminals together may cause burns or a fire.

d) **Under abusive conditions, liquid may be ejected from the battery; avoid contact. If contact accidentally occurs, flush with water. If liquid contacts eyes, additionally seek medical help.** Liquid ejected from the battery may cause irritation or burns.

e) **Do not use a battery pack or tool that is damaged or modified.** Damaged or modified batteries may exhibit unpredictable behavior resulting in fire, explosion, or risk of injury.

f) **Do not expose a battery pack or tool to fire or excessive temperature.** Exposure to fire or temperature above 212°F(100 °C) may cause explosion.

g) **Follow all charging instructions and do not charge the battery pack or tool outside the temperature range specified in the instructions.** Charging improperly or at temperatures outside the specified range may damage the battery and increase the risk of fire.

● **Service**

a) **Contact PRORUN Customer Service with questions or issues with this machine.** This will ensure that the safety of the power tool is maintained.

b) **Never service damaged battery packs.** Service of battery packs should only be performed by the manufacturer or authorized service providers.

⚠ WARNING: Read all instructions before using this appliance.

⚠ WARNING: When using electric gardening appliances, basic safety precautions should always be followed to reduce the risk of fire, electric shock, and personal injury, including the following:

- **Training**

- a) **Read the instructions carefully.** *Be familiar with the controls and the correct use of the machine.*

- b) **Keep in mind, that the operator or user is responsible for accidents or hazards occurring to other people or their property.**

- **Preparation**

- a) **This machine is designed for maintaining lawns and gardens in the manner and in the conditions described in this manual.**

- Use of the machine for operations different than intended could result in serious injury or death.*

- Do not use it for any other purposes. Misuse may result in personal injury or property damage, including damage to the machine.*

- Use the machine, battery, and charger only as described in this manual.*

2. SAFETY INSTRUCTIONS FOR CHAINSAW

- **General chainsaw safety warnings:**

- a) **Keep all parts of the body away from the saw chain when the chainsaw is operating. Before you start the chainsaw, make sure the saw chain is not contacting anything. A moment of inattention while operating chainsaws may cause entanglement of your clothing or body with the saw chain.**

- b) **Always hold the chainsaw with your right hand on the rear handle and your left hand on the front handle. Holding the chainsaw with a reversed hand configuration increases the risk of personal injury and should never be done.**

- c) **Hold the chainsaw by insulated gripping surfaces only, because the saw chain may contact hidden wiring. Saw chains contacting a "live" wire may make exposed metal parts of the chainsaw "live" and could give the operator an electric shock.**

- d) **Wear eye protection. Further protective equipment for hearing, head, hands, legs, and feet is recommended. Adequate protective equipment will reduce personal injury from flying debris or accidental contact with the saw chain.**

- e) Do not operate a chainsaw in a tree, on a ladder, from a rooftop, or any unstable support.** *Operation of a chainsaw in this manner could result in serious personal injury.*
- f) Always keep proper footing and operate the chainsaw only when standing on fixed, secure, and level surface.** *Slippery or unstable surfaces may cause a loss of balance or control of the chainsaw.*
- g) When cutting a limb that is under tension, be alert for spring back.** *When the tension in the wood fibers is released, the spring-loaded limb may strike the operator and/or throw the chainsaw out of control.*
- h) Use extreme caution when cutting brush and saplings.** *The slender material may catch the saw chain and be whipped toward you or pull you off balance.*
- i) Carry the chainsaw by the front handle with the chainsaw switched off and away from your body. When transporting or storing the chainsaw, always fit the guide bar cover.** *Proper handling of the chainsaw will reduce the likelihood of accidental contact with the moving saw chain.*
- j) Follow instructions for lubricating, chain tensioning and changing the bar and chain.** *Improperly tensioned or lubricated chain may either break or increase the chance for kickback.*
- k) Cut wood only. Do not use chainsaw for purposes not intended. For example: do not use chainsaw for cutting metal, plastic, masonry, or non-wood building materials.** *Use of the chainsaw for operations different than intended could result in a hazardous situation.*
- l) Do not attempt to fell a tree until you have an understanding of the risks and how to avoid them.** *Serious injury could occur to the operator or bystanders while felling a tree.*
- m) Follow all instructions when clearing jammed material, storing, or servicing the chainsaw. Make sure the switch is off and the battery pack is removed.** *Unexpected actuation of the chainsaw while clearing jammed material or servicing may result in serious personal injury.*

● **Causes and operator prevention of kickback:**

Kickback may occur when the nose or tip of the guide bar touches an object, or when the wood closes in and pinches the saw chain in the cut.

Tip contact in some cases may cause a sudden reverse reaction, kicking the guide bar up and back towards the operator.

Pinching the saw chain along the top of the guide bar may push the guide bar rapidly back towards the operator.

Either of these reactions may cause you to lose control of the saw which could result in serious personal injury. Do not rely exclusively upon the safety devices built into your saw. As a chainsaw user, you should take several steps to keep your cutting jobs free from accident or injury.

Kickback is the result of chainsaw misuse and/or incorrect operating procedures or conditions and can be avoided by taking proper precautions as given below:

a) Maintain a firm grip, with thumbs and fingers encircling the chainsaw handles, with both hands on the saw and position your body and arm to allow you to resist kickback forces.

Kickback forces can be controlled by the operator if proper precautions are taken. Do not let go of the chainsaw.

b) Do not overreach and do not cut above shoulder height.

This helps prevent unintended tip contact and enables better control of the chainsaw in unexpected situations.

c) Only use replacement guide bars and saw chains specified by the manufacturer. *Incorrect replacement guide bars and saw chains may cause chain breakage and/or kickback.*

d) Follow the manufacturer's sharpening and maintenance instructions for the saw chain. *Decreasing the depth gauge height can lead to increased kickback.*

3. TRANSPORTING AND STORAGE

a) When transporting or storing the chainsaw always fit the guide bar cover. *Proper handling of the chainsaw will decrease the risk of personal injury from the blades.*

b) Unintentional starting may result in personal injury or property damage. *Remove the battery before inspecting the chainsaw or carrying out any cleaning, maintenance, or repair work, before storing, and any other time the chainsaw is not in use.*

c) **Improper storage can result in unauthorized use, damage to the machine, battery and charger and an increased risk of fire, electric shock, and other personal injury or property damage.**

– *Before storing, always unplug the charger from the wall outlet and remove the battery.*

– *Store the machine, battery, and charger indoors in a dry, secure place out of the reach of children and other unauthorized users.*

4. BATTERY AND BATTERY CHARGER

This section describes the battery and battery charger safety for your battery product.

Only use original batteries for products and only charge them in an original battery charger.

● Battery charger

The battery chargers, are only used for charging of PRORUN® 60V replacement batteries.

– This manual contains important safety and operating instructions for battery charger.

– Before using battery charger, read all instructions and cautionary markings on battery charger, and product using battery.

⚠ CAUTION! Charge only Li-ion batteries recommended by the manufacturer.

– Other types of batteries may burst causing personal injury and damage.

– If the shape of the plug does not fit the power outlet, use an attachment plug adapter of the proper configuration for the power outlet.

⚠ WARNING! Minimize the risk of electric shock or short circuit as follows:

– Never insert any object into the charger's cooling slots. Do not try to dismantle the battery charger.

– Never connect the charger terminals to metal objects as this can short circuit the battery charger.

– Use approved and intact wall sockets.

⚠ WARNING! This machine produces an electromagnetic field during operation. This field may under some circumstances interfere with active or passive medical implants. To reduce the risk of serious or fatal injury, we recommend persons with medical implants consult their physician and the medical implant manufacturer before operating this machine. Do not use product when a thunderstorm is approaching.

– Unplug the charger from the wall outlet before inspecting or cleaning the charger.

– Regularly check that the battery charger connection wire is intact and that there are no cracks in it. Replace the charger if the power supply cord becomes worn or damaged. The power supply cord cannot be repaired or replaced.

– Never carry the battery charger using the cord and never pull out the plug by pulling the cord.

– Keep all cords and extension cords away from water, oil, and sharp edges. Make sure the cord is not pinched in doors, fences, or the like. Otherwise, it can cause the object to become live.

– Never clean the battery or the battery charger with water.

– Never allow the children to use the battery charger.

When charging, the charger must be placed in a well-ventilated area and under a roof to keep out moisture.

⚠ WARNING! Do not charge non-rechargeable batteries in the battery charger or use them in the machine.

⚠ WARNING! Do not use the battery charger close to corrosive or flammable materials. Do not cover the battery charger. Pull out the plug to the battery charger in the event of smoke or fire. Risk of fire.

– Use the battery charger only when the surrounding temperature is between 41 °F(5 °C) and 113 °F (45 °C). Use the charger in an environment which is well ventilated, dry, and free from dust.

Do not use:

- A faulty or damaged battery charger
- The battery in the battery charger outdoors.

Do not charge:

- Or never use a faulty, damaged, or deformed battery.
- The battery in the rain or in wet conditions.
- The battery in direct sunlight.
- The battery in the battery charger outdoors.

● **Battery**

– Do not dismantle, open or shred secondary batteries.

– Keep batteries out of the reach of children.

– Do not expose batteries to heat or fire. Avoid storage in direct sunlight.

– Do not short-circuit a battery. Do not store batteries haphazardly in a box or drawer where they may short-circuit each other or be short-circuited by other metal objects.

– Do not remove a battery from its original packaging until required for use.

– Do not subject batteries to mechanical shock.







– In the event of a cell leaking, do not allow the liquid to come in contact with the skin or eyes. If contact has been made, wash the affected area with copious amounts of water and seek medical



















advice.

- Do not use any charger other than that specifically provided for use with the equipment.
 - Do not use any battery which is not designed for use with the equipment.
 - Always purchase the battery recommended by the device manufacturer for the equipment.
 - Keep batteries clean and dry.
 - Wipe the battery terminals with a clean dry cloth if they become dirty.
 - Secondary batteries need to be charged before each use. Always use the correct charger and refer to the manufacturer’s instructions or equipment manual for proper charging instructions.
 - Do not leave a battery on prolonged charge when not in use.
 - After extended periods of storage, it may be necessary to charge and discharge the batteries several times to obtain maximum performance.
 - Retain the original product literature for future reference.
 - Use the battery only in the application for which it was intended.
- When possible, remove the battery from the equipment when not in use.
- Dispose of properly.

5. SYMBOLS

This page depicts and describes safety symbols that may appear on this product. Read, understand, and follow all instructions on the machine before attempting to assemble and operate it.

	Safety Alert	Because a chainsaw is a high-speed cutting tool, special safety precautions must be observed to reduce the risk of personal injury.
	Read the Operation's Manual	It is important that you read, fully understand, and observe the following safety precautions and warnings. Read the instruction manual and the safety precautions periodically.
	Do not expose to rain	Protect the tool, battery, and charger from rain, water, liquids, and damp conditions. Keep the tool, battery, and charger dry.
	Do not use chainsaw one-handed	To reduce the risk of serious or fatal injury to the operator or bystanders from loss of control, never use the chain saw with one hand.
	Always use chainsaw two-handed	Always hold the chainsaw firmly with both hands when you are working. Place your left hand on the front handle and your right hand on the rear handle.
	Kickback warning	Beware of chainsaw kickback and avoid contact with bar tip.

	Wear eye, ear, and head protection	To reduce the risk of injury to you, always wear safety goggles or safety glasses, sound barriers and safety hard hat when operating this product.
	Wear protective gloves	Always wear heavy duty nonslip gloves when handling the machine.
	Wear safety footwear	Wear sturdy boots with nonslip soles. Never wear sandals, flip-flops or go barefoot.
	Remove the battery	Remove the battery from chainsaw before cleaning or maintenance.
	Chain brake marking	Shows the directions that the chain brake is released (white arrow) and activated (black arrow).
	Chain direction marking	Shows the direction of the saw chain installation.
	Chain oil marking	The port to replenish the chain oil.
	Never expose to fire	Risk of fire, explosion and/or burns, including chemical burns. Never incinerate or place the battery on or near fires, stoves, or other high-temperature locations.
	Never heat the battery	Do not disassemble, crush, heat above 212°F (100°C). Never expose the battery to high pressures.
	Never immerse in water	To reduce the risk of personal injury or property damage from a short circuit, fire, or explosion. Never immerse the battery in water or other liquids.
	Recycling	Take the chainsaw, charger, accessories, and packaging to an approved disposal site for environmentally friendly recycling.
	Waste	Symbols on the product or its packaging indicate that this product cannot be handled as domestic waste. This product must be deposited at an appropriate recycling facility.
	Indoor use only	Use and store charger only indoors in dry rooms.
	Class II tool	Battery charger belongs to Class II tools. It is intended for charging Li-ion batteries and having an output at safe extra-low voltage.
	Fuse	T3.15A time-lag miniature fuse-link
	Alternating Current	Type of current
	Lithium-ion battery	Type of battery
	Direct Current	Type of current

Below units may be used in manual:

V	Volts	Voltage
A	Amperes	Current
Hz	Hertz	Frequency(cycles per second)
W	Watts	Power
min	Minutes	Time

mm	Millimeter	Length or size
in.	Inch	Length or size
Kg	Kilogram	Weight
Lbs.	Pound	Weight
RPM	Revolutions per minute	Rotational speed

⚠ DANGER! People with electronic devices, such as pacemakers, should consult their physician(s) before using this product. Operation of electrical equipment in close proximity to a heart pacemaker could cause interference or failure of the pacemaker.

6. SPECIFICATIONS

Machine model	PCS160H
Voltage	DC 60V
Motor type	Permanent Magnet DC
Maximum speed of saw chain	21.9 m/s (48.9 MPH)
Guide bar length	16 in. (370 / 375 mm), 18 in. (425 mm)
Weight (without saw chain, guide bar, guide bar cover, oil, and battery)	7.38 Lbs. (3.35 Kg)
Chain pitch	3/8 in. (9.525 mm)
Chain gauge	0.50 in. (1.27 mm) or 0.43 in. (1.09 mm)
Drive sprocket	6T×9.525 mm (3/8")
Volume of chain oil tank	8.5 oz (250 cm ³)
Recommended guide bar and saw chain combinations	1. Oregon 164MLEA041+90PX056X 2. Oregon 160SDEA041+91P057X 3. Oregon 180SDEA041+91P062X
Vibration according to IEC 62841-4-1*	Front handle: 4.34 m/s ² Rear handle: 4.92 m/s ²
The vibration uncertainties value	K=1.5 m/s ²
Battery charger	PC16026
Charger input	AC 100-240 V, 50/60 Hz, 170 W
Charger output	DC 62.4 V, 2.6 A
Batteries	PB 16050 or PB 16025
Battery rated parameter	DC 54 V, 5.0 Ah or 2.5Ah

*The declared vibration total value has been measured in accordance with a standard test method and may be used for comparing one tool with another. The declared vibration total value may also be used in a preliminary assessment of exposure. The vibration emission during actual use of the power tool can differ from the declared total value depending on the ways in which the tool is used.

7. KNOW YOUR CHAINSAW

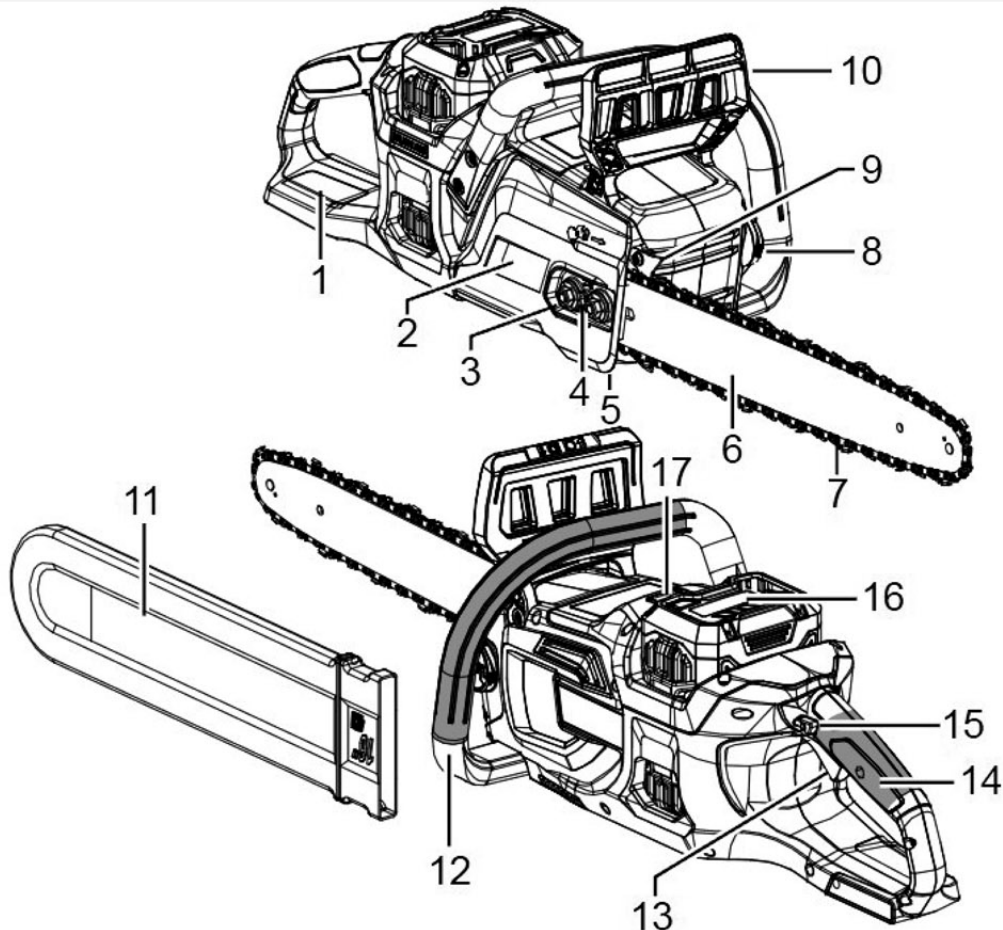

1. Rear hand guard

Extension on the lower part of the rear handle for protecting the hand from the saw chain if it breaks or derails.

2. Chain sprocket cover

Covers the saw chain drive sprocket.

3. Locking nuts

Locks or releases the chain sprocket cover.

4. Chain tension screw

Tightens or releases the saw chain.

5. Chain catcher

Protects the operator from injury if saw chain breakage occur.

6. Guide bar

Attachment that supports and guides

the saw chain.

7. Saw chain

Attachment, serving as a cutting tool, consisting of drive links and cutters.

8. Chain oil tank cap

Closes the chain oil tank.

9. Bumper spikes

Device, fitted in front of the guide bar mounting point, acts as a pivot when in contact with a tree or log.

10. Chain kickback brake guard

Serves as the lever for chain brake activation (forward/brake position, backwards/operating position). Guard provides protection against projecting branches and helps prevent the left

hand from touching the saw chain if it slips off the front handle.

11. Chain scabbard

Protects the operator from injuries and the chain blades from damaged during transportation and storage.

12. Front handle

Support handle and grasping surface (designated in gray) located at or towards the front of the machine.

13. Variable-speed trigger

Turns the saw chain On and Off and adjusts the chain speed.

14. Rear handle

Support handle and grasping surface (designated in gray) located towards the rear of the machine.

15. Lock-off button

Helps to prevent accidental or unauthorized activating of the trigger switch. It must be depressed before the variable-speed trigger can be activated.

16. Battery

Supplies electrical power to the motor.

17. Release button

Secures the battery in the machine and release it from the machine.

IMPORTANT! The safe use of this product requires an understanding of the information located on the product and in this operator's manual, as well as a knowledge of the projects you are attempting. Before use of this product, familiarize yourself with all operating features and safety rules.

This machine is intended to cut trees, limbs, or similar vegetation. This machine must not be used for cutting other materials, such as plastic, stone, metal, or materials that are harmful to health.

8. BATTERY AND CHARGER OPERATION

This section describes the battery and battery charger safety for your battery product.

Only use PRORUN® original batteries for PRORUN products and only charge them in an original battery charger from PRORUN. The batteries are software encrypted.

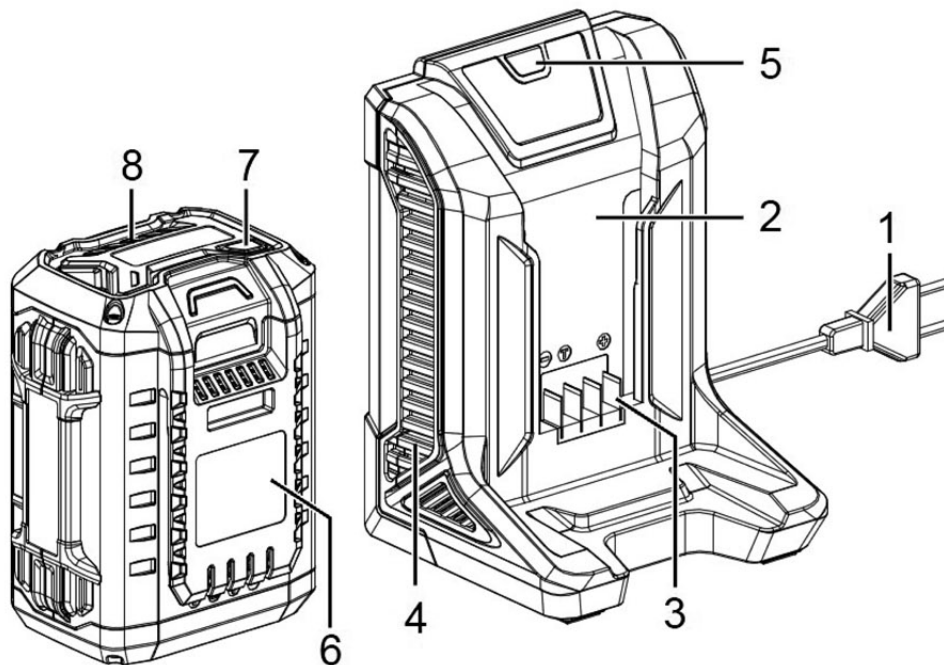

1. Electric plug

2. Battery charger

3. Electrical terminal

4. Cooling slots

5. Charger LED light

6. Battery

7. Electric charge status button

8. 5 LED charge status indicator

NOTE! The specifications of the plugs can be different by country, the picture is only for reference. If the shape of the plug does not fit the power outlet, use an attachment plug adapter of the proper configuration for the power outlet.

 **WARNING!** Risk of electric shock and short circuiting. Use approved and intact wall sockets. Make sure that the power cord is not damaged. Replace power cord if it appears to be damaged in any way.

● **Connect the battery charger**

Connect the battery charger (2) to the voltage and frequency specified on the rating plate.

- Put the electric plug (1) in an earthed or grounded socket-outlet.
- The charging indication LED (5) will shine green indicating that the charger is working correctly.
- After 5 second, the light will turn off if no battery in the charger.

● **Connect the battery to the battery charger**

The battery (6) must be charged before using it the first time. The battery is only 30% charged when delivered.

NOTE! Monitor the charging process while charging a battery. It is recommended to remove the battery from the battery charger when the battery is fully charged, or the charger is disconnected from the power supply.

- Align the raised ribs of the battery pack with the mounting slots in the charger; slide the battery pack down onto the charger and engage the battery with the charger's electrical terminals.
- The charger will communicate with the battery pack to evaluate the condition of the battery pack.
- While the battery pack is charging, the charger LED light (5) will shine as follows to indicate the charging process and levels:



The charger's LED light flashes green when the battery is charging.



The charger's LED light shines consistently green if the battery is fully charged.



The battery will not be charged if the battery temperature is in deviation from normal. In that case the fault LED light flashes red until the battery cools or heats to normal temperature.



NOTE! The battery will never be charged if the battery is damaged. In that case the charger LED light shine consistently red.

- The five LEDs on the battery pack indicate the current charged power level. Press the battery's electric energy button to check the power level of the battery.
- When the battery is full charged, the battery charger will stop charging (switch to stand by).
- It is recommended to remove the battery from the battery charger when the battery is fully charged, or the charger is disconnected from the power supply.
- Pull out the plug. Never use the power supply cable to disconnect the charger from the wall socket.

● **Maintenance**

- Make sure the battery and battery charger are clean and that the terminals on the battery and the battery charger are always clean and dry before the battery is placed in the battery charger.
- Keep the battery guide tracks clean. Clean plastic parts with a clean and dry cloth.

● **Transport and storage**

- Store the equipment in a lockable area so that it is out of reach of children and unauthorized persons.
- Store the battery and the battery charger in a dry, moisture-free, and frost-free space.
- Store the battery where the temperature is between 41 °F (5 °C) and 77 °F (25 °C) and never in direct sunlight.
- Store the battery charger only in an enclosed and dry space.
- Be sure to store the battery separate from the battery charger.

● Fault codes

Troubleshooting the battery and the battery charger during charging.

LED display	Possible faults	Possible action
Charger LED flashing red.	The battery is okay but may be experiencing temperature deviation.	Charge the battery in surroundings where temperatures are between 41 °F (5 °C) and 104 °F (40 °C). Wait for the battery to cool down.
Charger LED shines consistently red.	Battery is damaged. Charger is damaged.	Contact PRORUN Customer Service.

9. ASSEMBLY INSTRUCTIONS

● Unpacking.

This machine requires assembly of the guide bar and saw chain.

Carefully remove the product and any accessories from the box. Make sure that all items listed in the packing list are included.

- Inspect the product carefully to make sure that no breakage or damage occurred during shipping.
- Do not discard the packing material until you have carefully inspected and satisfactorily operated the product.

● Packing list

- | | | |
|--------------------|--------------------|-------------------------|
| 1. Chainsaw | 4. Saw chain | 7. Scrench (multi-tool) |
| 2. Guide bar cover | 5. Battery charger | 8. Operator's manual |
| 3. Guide bar | 6. Battery | |

● Install the guide bar and saw chain

NOTE: Small direction arrows are engraved on the saw chain and molded onto the chainsaw housing. When looping the saw chain onto the guide bar, make sure that, before and after mounting the guide bar onto the power head, the direction of the arrows on the saw chain must correspond to the rotation direction arrow on the chainsaw housing.

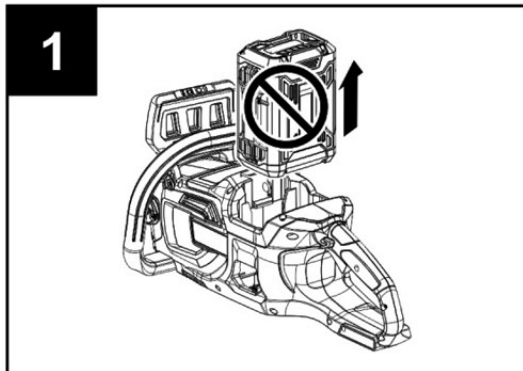

1. Remove battery before accessing the guide bar and saw chain. (See Fig 1)

Position the chainsaw on a firm, flat surface so that the chain sprocket cover is facing you.

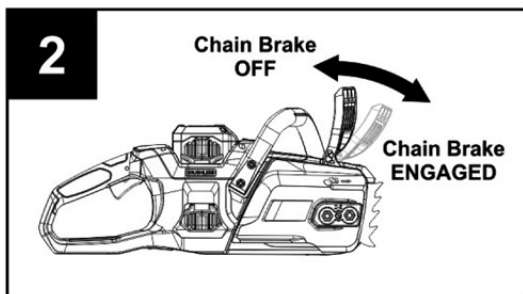

2. Pull the chain kickback brake guard (10) back towards the rear to make sure the chain brake is not engaged. (See Fig 2)

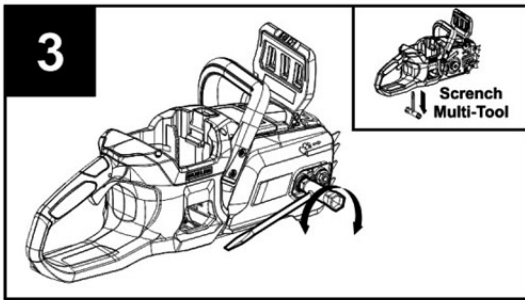

3. Use the scrench multi-tool found underneath the rear handle (14) to disengage the two locking nuts (3) and remove the chain sprocket cover (2). (See Fig 3)

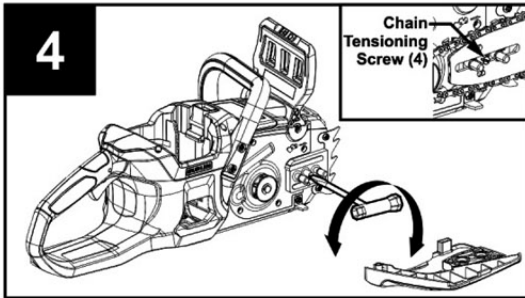

4. Use the scrench multi-tool to rotate the chain tension screw (4) counterclockwise as far as it will turn to allow for maximum clearance for installing saw chain. (See Fig 4)

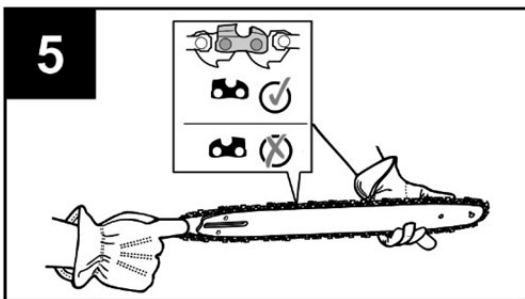

5. Lay the new saw chain in a loop on a flat surface and straighten any kinks. Seat the saw chain around the guide bar and align the chain drive links into the guide bar's groove. Position the chain so there is a loop at the back of the guide bar. (See Fig 5)

NOTE: Small direction arrows are engraved on the saw chain and molded onto the chainsaw housing. When looping the saw chain onto the guide bar, make sure that the direction of the arrows on the saw chain correspond to the rotation direction arrow on the chainsaw housing. (See Fig 5)

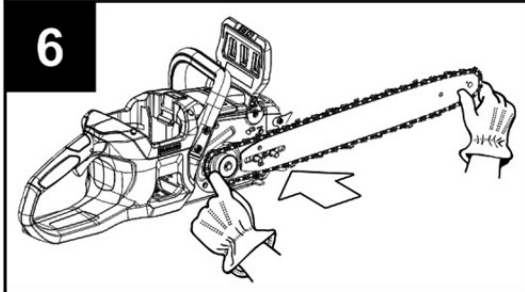

6. Hold the chain in position on the guide bar and place the loop around the drive sprocket of the power head. (See Fig 6)

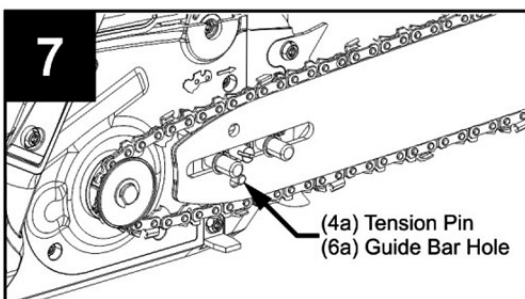

7. Mount the guide bar (6) to the chainsaw by aligning the guide bar hole (6a) to the tension pin on the chainsaw (4a). (See Fig 7)

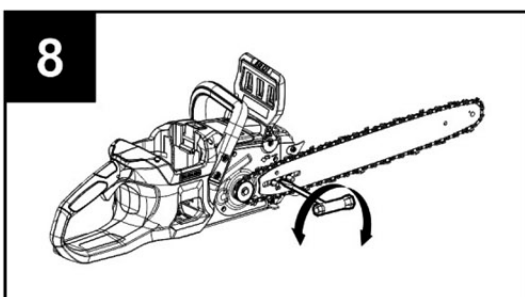

8. Use the scrench multi-tool to rotate the chain tension screw (4) clockwise to preliminarily tighten the saw chain and guide bar assembly. (See Fig 8)

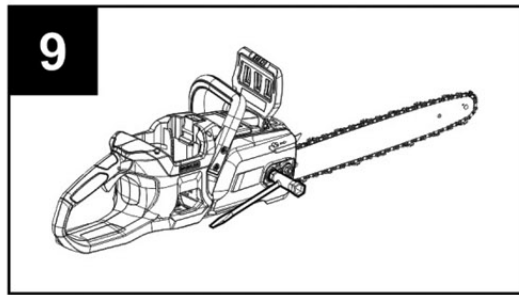

9. Install the drive sprocket cover and rotate the two locking nuts clockwise just enough to hold the chain sprocket cover in position. (See Fig 9)

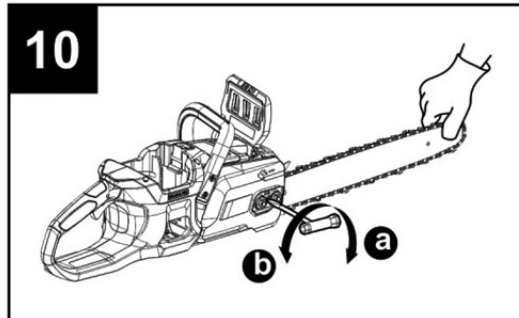

10. Hold up the tip of the guide bar and use the scrench multi-tool to adjust the saw chain tension. Turn the chain tension screw clockwise (b to a) until the tie straps just touch the bottom side of the bar rail. (See Fig 10)

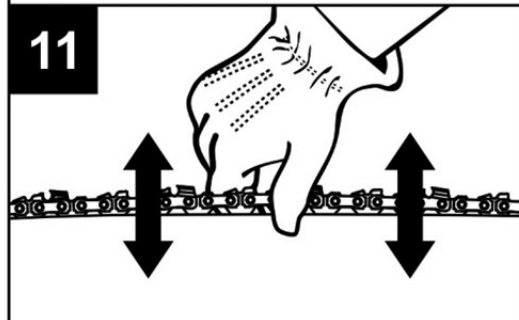

11. Check the chain for smooth rotation and proper tension while moving it by hand. If necessary, readjust with the drive sprocket cover loose. If the saw chain does not move, check the chain kickback brake guard (10) to make sure the chain brake is not engaged. (See Fig 2)

Tighten the chain by rotating the chain tension screw clockwise (b to a). Loosen the chain by turning the chain tension knob counterclockwise (a to b). Chain should "give" approximately a 1/4 inch from the bar without much effort. (See Fig 11)

Use the scrench multi-tool to rotate the locknuts clockwise (b to a) with the bar tip held up and fix the guide bar and drive sprocket cover securely. (See Fig 9)

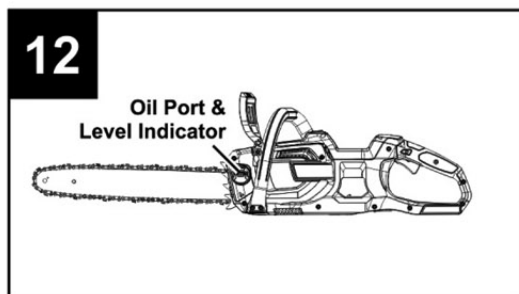

12. Be sure that chain oil has been installed and at the correct level before operation. (See Fig 12)

NOTE: The chainsaw is not filled with chain oil at the time of purchase. It is essential to fill the reservoir with the specified amount of oil prior to all uses. Operating the chainsaw without the specified level of chain oil with result in damage to the chain, as well as reduce the life cycle of the saw.

10. OPERATION

● Replenish the chain oil (See Fig 13)

BAR & CHAIN OIL IS REQUIRED. Chainsaws requires all-season formula bar & chain oil (sold separately). Be sure the oil reservoir is filled before operation. This oil allows the chain to move smoothly around the bar reducing stress on the motor, extends the life of the bar & chain, helps resist build-up of resins, sap, and gum and prevents wear, corrosion and rust.

Check oil level before starting work, while sawing, and each time the battery is charged.

- The service life of the chain and guide bar depends on the quality of the lubricant. It is therefore essential to use on a specialty chain lubricant.

- Do not operate the chainsaw without lubricant. Replenish chain lubricant before the container is empty.

⚠ Do not use waste oil. Renewed contact with waste oil can cause skin cancer. Moreover, waste oil is environmentally harmful.

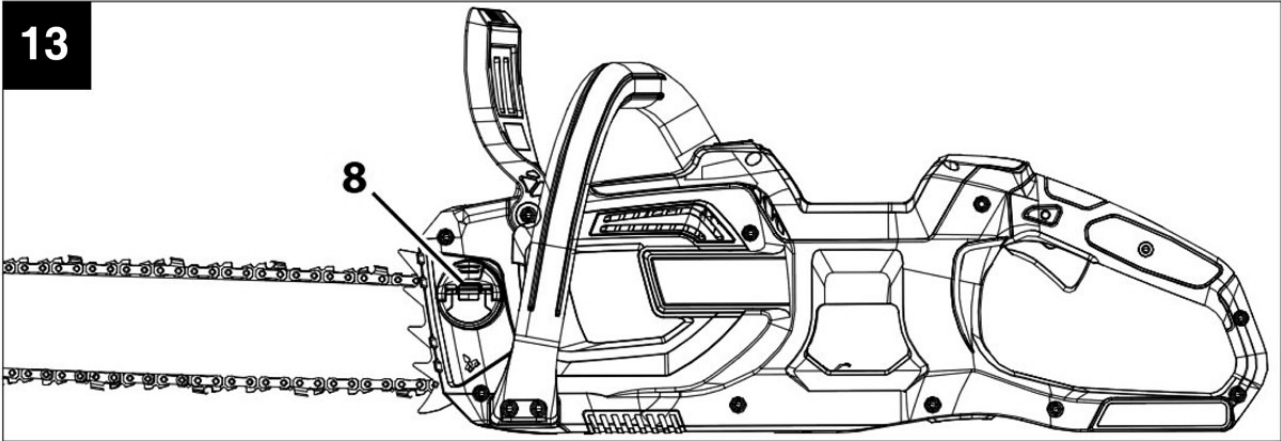
13

● **Install the battery pack** (See Fig. 14)

Align the raised ribs of the battery pack with the mounting slots in the chainsaw battery port; slide the battery pack down into the machine until you hear an audible click.

● **Remove the battery pack** (See Fig. 14)

Depress the release button (17) to release battery pack (16) and pull out the battery simultaneously.

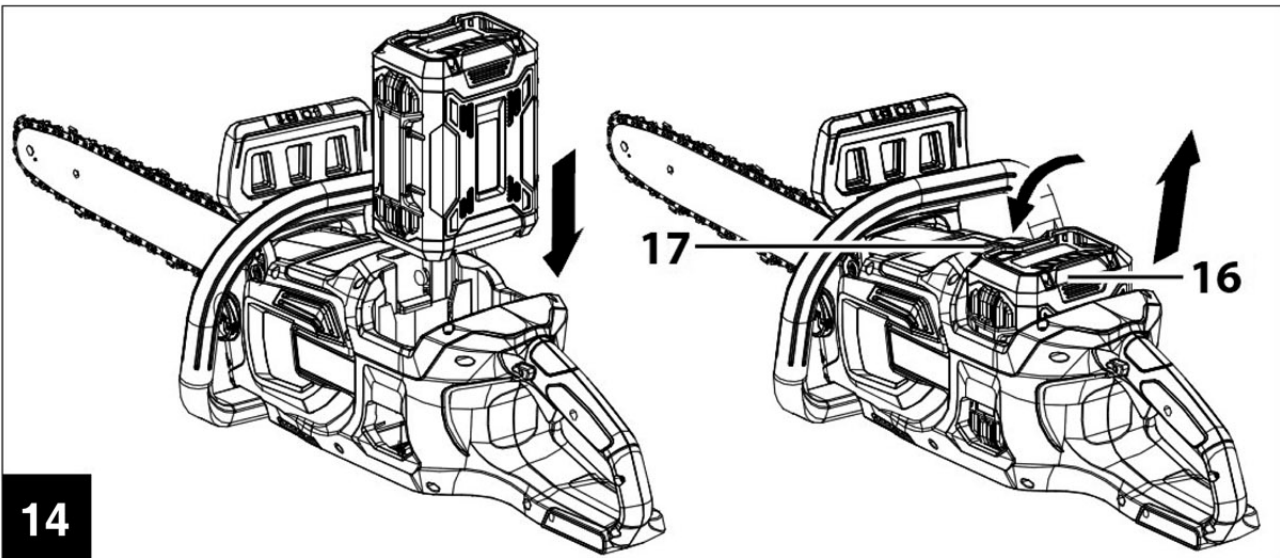
**14**

● **Switching on the machine** (See Fig. 15)

- Remove the chain scabbard (11).
- Hold the machine with both hands; right hand on Rear Handle (14) and left hand on Front Handle (12). Wrap hands tightly around both handles.
- Make certain that the saw chain has not yet been positioned for cutting and is not touching any other objects.
- Pull chain kickback brake guard (10) towards the front handle until it engages audibly, and the front hand guard is in the operating position. (See fig.17)
- Press lock-off button (15) with thumb, depress variable-speed switch (13) with index finger at the same time.
- It shall not be necessary to sustain the

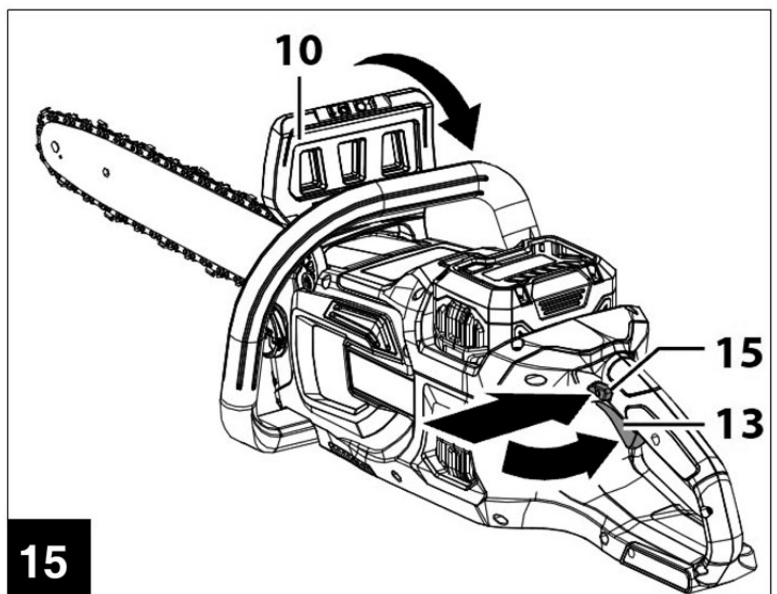
**15**

18

actuation of the lock-off button after the variable-speed switch is activated.

- The motor will not run unless the chain kickback brake guard (10) is in the operation position. (See Fig. 10)
- The lock-off button shall return to the original locked state when the variable-speed switch is released. To re-engage, press the lock-off button to release variable-speed switch before switching on the machine.

● Checking the oil delivery (See Fig. 16)

IMPORTANT! Never use the machine without lubrication!

- Always check chain lubrication and the oil level in the tank before starting work.
- Switch on the machine, keep it running at low speed and check if the chain oil is being delivered as shown in the accompanying illustration.



● Checking the chain brake (See Fig. 17)

This machine is equipped with a safety brake system.

Normally, the chain brake is activated automatically by inertial force. It can also be activated manually by pushing the chain kickback brake guard (10) down toward the front.

To check that the chain brake works efficiently, proceed as follows:

- Make sure you are holding the machine firmly with both hands when you are operating the machine.
- Place the chainsaw on a horizontal surface with plenty of clearance for the saw to be safely activated.
- Turn the chainsaw on. While the chain is moving, push the chain kickback brake guard (10) forward (a to b) using the back of your left hand and making sure you do not expose your fingers to the moving saw chain. The chain must stop immediately.
- Release the variable-speed trigger (13). Pull the chain kickback brake guard (10) back toward the front handle (12) until it engages audibly to release the chain brake. The chainsaw should start normally in this position.

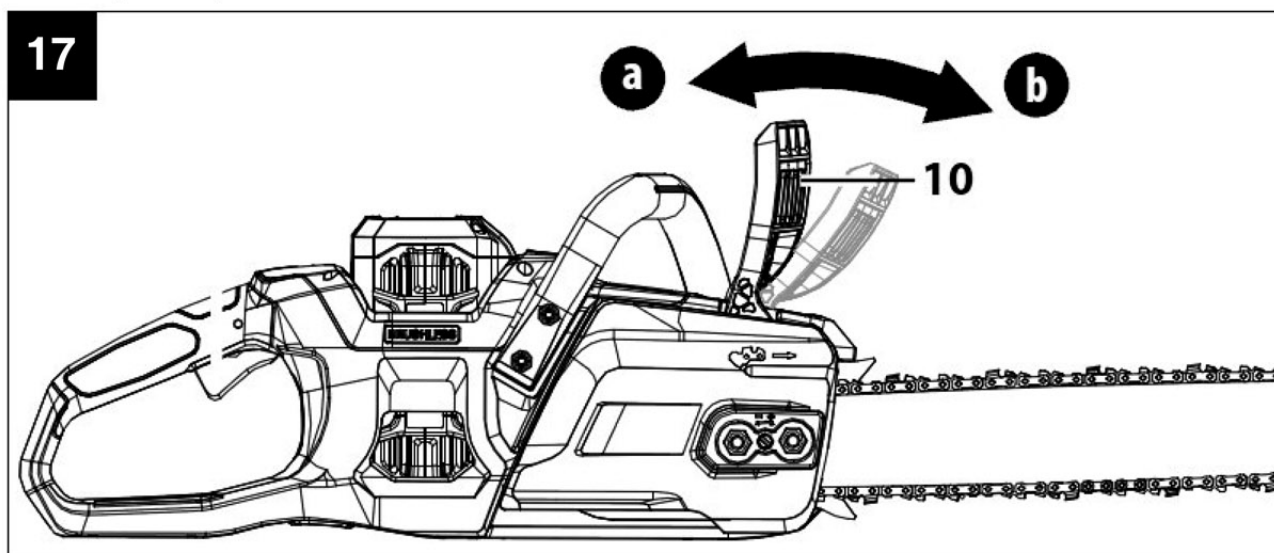

● Checking the machine

Before starting work please:

- Daily inspection before use and after dropping or other impacts to identify significant damage or defects.
- Check that all the screws on the machine and the bar are tightly fastened.
- Check that the chain is sharp and there are no signs of any damage.

- Check that handgrips and protection devices are clean and dry, correctly mounted, and well fastened to the machine.
- Check that the chain brake is working efficiently.
- Check the chain tension.
- Always follow all the safety regulations which can restrict the use of the machine.
- The chainsaw must only be used for cutting wood. It is forbidden to cut other types of material.
- Vibrations and kickback vary with different (non-wood) materials and would violate the requirements of the safety regulations.
- Do not use the chainsaw as a lever for lifting, moving, or splitting objects.
- Comply with local regulations and provisions for the disposal of waste materials after sawing.
- Before felling or delimiting for the first time, practice cutting logs on a sawhorse or cradle, to become familiar with the machine and the most suitable sawing techniques.

● Guard against kickback

⚠ Warning! Kickback occurs when the tip of the chain comes in contact with an object or when the wood contracts and jams the chain during sawing. This contact with the tip of the chain can cause a rapid backward motion, pushing the guide bar up and towards the operator. This also happens when the chain is jammed along the upper part of the bar. In both cases, kickback can cause the operator to lose control of the chainsaw, leading to serious consequences. (See Fig. 18)

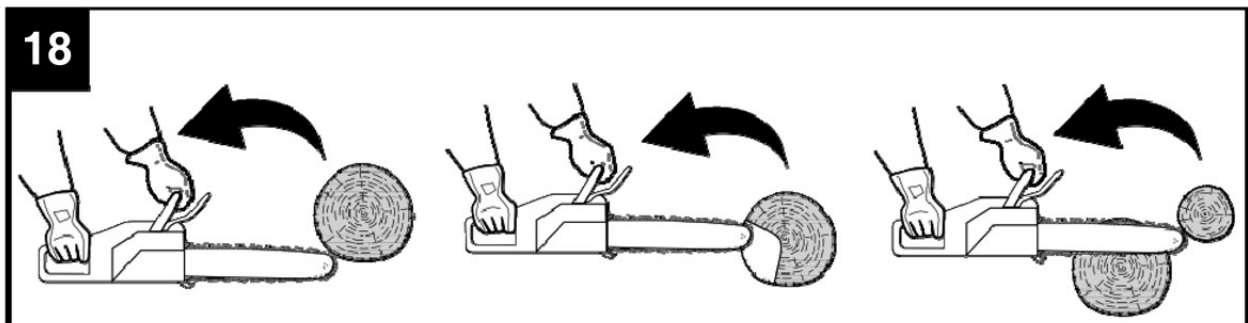

Linear Kickback can happen when the wood on either side of a cut closes in and pinches the moving saw chain along the top of the guide bar. Pull-In can happen when the moving chain on the top or bottom of the guide bar hits the wood. (See Fig. 19)

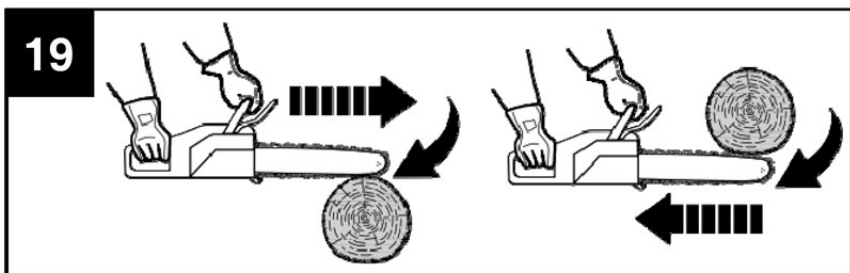

Follow the chapter **SAFETY INSTRUCTIONS FOR CHAINSAWS** and take the following additional steps to reduce the chance of accident or injury:

- Check the chain brake for proper operation before each use and that the chain is sharp.
- Always keep proper footing and balance. Take extra care when working on steep slopes or inclines.
- Make sure the area of operation is free from obstructions. Do not let the tip of the guide bar contact any object, such as a log, branch, the ground or other obstruction.
- Always inspect the wood before cutting. Foreign objects could damage the unit or cause serious personal injury.
- Stand slightly to the left of the unit to avoid being in the direct line of the saw chain.
- Never start the chainsaw when the guide bar is inside an existing cut.
- Do not cut more than one log or branch at a time.
- Do not install a bow bar/clearing guide on this unit. Bow bar/clearing guides have larger kickback zones, which increase the chance of kickback and significant injury.

● Using the bumper spikes (See Fig 20)

- Dig the spiked bumper into the log and use it as a pivot. Cut with an arched motion to make the bar penetrate the wood.
- Repeat several times if necessary, changing the point where you plant the bumper spikes.

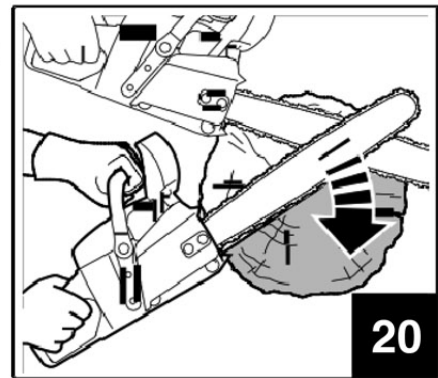

● Instructions concerning the proper techniques for basic felling, limbing, and cross-cutting

Felling a tree

When cross-cutting/bucking and felling operations are being performed by two or more persons at the same time, the felling operations should be separated from the cross-cutting/bucking operation by a distance of at least twice the height of the tree being felled. Trees should not be felled in a manner that would endanger any person, strike any utility line, or cause any property damage. If the tree does make contact with any utility line, the company should be notified immediately.

The chainsaw operator should keep on the uphill side of the terrain as the tree is likely to roll or slide downhill after it is felled.

An escape path should be planned and cleared as necessary before cuts are started. The escape path should extend back and diagonally to the rear of the expected line of fall as illustrated in Figure 21.

- Before felling is started, consider the natural lean of the tree, the location of larger branches and the wind direction to judge which way the tree will fall.
- Remove dirt, stones, loose bark, nails, staples, and wire from the tree.

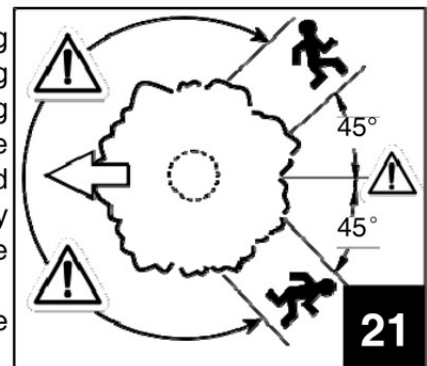

Notching undercut

Make the notch (B) 1/3 the diameter of the tree, perpendicular to the direction of falls as illustrated in Figure 22. Make the lower horizontal notching cut first. This will help to avoid pinching either the saw chain or the guide bar when the second notch is being made.

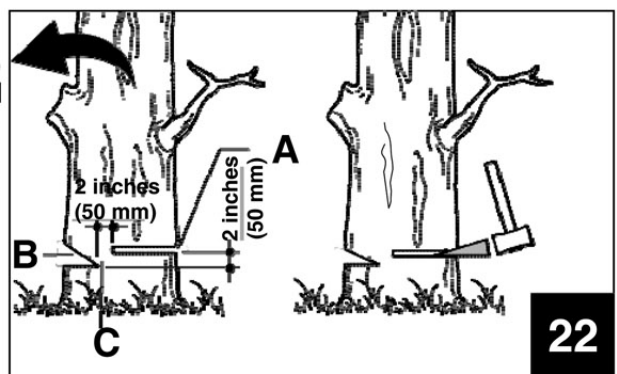

Felling back cut

Make the felling back cut (A) at least two inches (50mm) higher than the horizontal notching cut as illustrated in Figure 15. Keep the felling back cut parallel to the horizontal notching cut. When making the felling back cut, stop approximately two inches (50mm) from the notch so enough wood is left to function as a hinge. The hinge wood keeps the tree from twisting and falling in the wrong direction. Do not cut through the hinge (C).

As the felling cut gets close to the hinge, the tree should begin to fall. If there is any chance that the tree may not fall in desired direction or that it may rock back and bind the saw chain, stop cutting before the felling back cut is complete. Next, use wedges of wood, plastic, or aluminum to open the cut and drop the tree along the desired line of fall.

and drop the tree along the desired line of fall.

- When the tree begins to fall, remove the chainsaw from the cut, stop the motor, put the chainsaw down, then use the retreat path planned.
- Be alert for overhead limbs falling and watch your footing.

Limbing a tree

Limbing is removing the branches from a fallen tree. When limbing, leave the larger lower limbs to support the main log off the ground. Remove the small limbs in one cut as illustrated in Figure 23. Branches under tension should be cut from the bottom up to avoid binding the chainsaw.

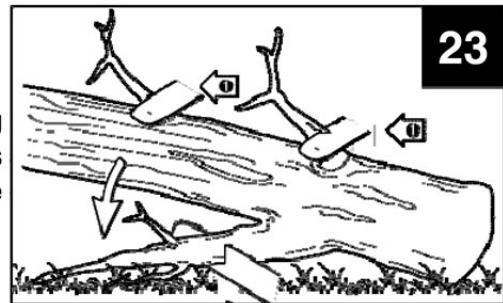

Cross-cutting/bucking a log

Cross-cutting/bucking is cutting a log into lengths. It is important to make sure your footing is firm, and your weight is evenly distributed on both feet. When possible, the log should be raised and supported by the use of limbs, logs, or chocks. Follow the simple directions for easy cutting.

- When the log is supported along its entire length as illustrated in Figure 24, limbs should be cut from the top. (overbuck).
- When the log is supported on one end, as illustrated in Figure 25, cut 1/3 the diameter from the underside (underbuck).
- Then make the finished cut by overbucking to meet the first cut.
- When the log is supported on both ends, as illustrated in Figure 26, cut 1/3 the diameter from the top (overbuck).
- Then make the finished cut by underbucking the lower 2/3 to meet the first cut.
- When cross-cutting/bucking on a slope always stand on the uphill side of the log, as illustrated in Figure 27.
- To maintain complete control when “cutting through” the main log, release the cutting pressure near the end of the cut without relaxing your grip on the chainsaw handles.
- Do not let the saw chain come in contact with the ground.
- After completing the cut, wait for the saw chain to stop before you move the chainsaw.
- Always stop the motor before moving from tree to tree.
- If there is a barrier between the cutting material and chainsaw, turn off the machine and wait until it stops completely. Wear safety gloves and remove the barrier.
- If the saw chain must be removed, please follow the relevant installation instructions within this manual. A trial run must be conducted after any cleaning or new installation of a saw chain.
- If vibration or mechanical noise is discovered, please stop using the machine and contact your dealer.

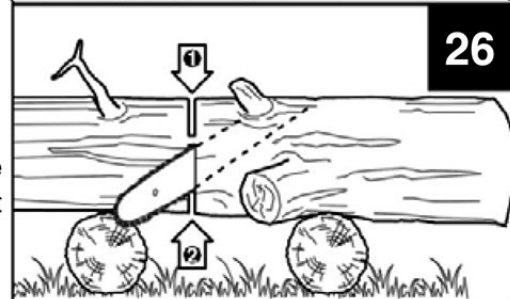
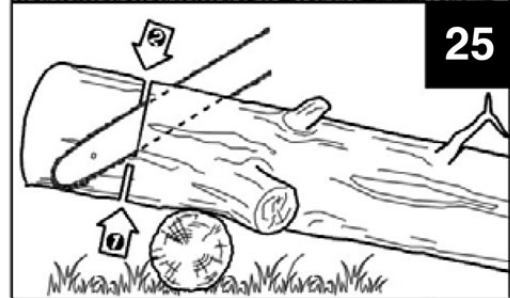
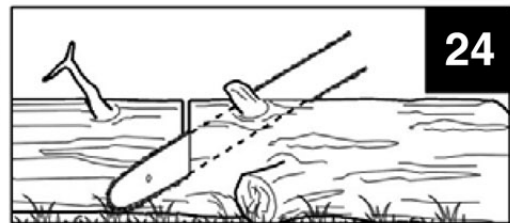

End of operations

Switch off the motor. Remove any traces of saw dust or oil deposits from the chain. Replace chain scabbard (11) over the bar and saw chain.

11. MAINTENANCE AND REPAIR

Servicing and repairing the machine

There are no user-authorized repairs.

– If your hedge trimmer has a malfunction, or is damaged, or requires servicing: Contact PRORUN Customer Service.

• **Servicing and repairing the battery. The battery requires no servicing and cannot be repaired.**

– If the battery has a malfunction or is damaged: Replace the battery.

• **Servicing and repairing the charger**

The charger requires no servicing and cannot be repaired.

– If the charger has a malfunction or is damaged: Replace the charger.

– If the connecting cable has a malfunction or is damaged: Do NOT use the charger and contact PRORUN Customer service.

⚠ WARNING! If the battery pack cracks or breaks, with or without leaks, do not recharge it and do not use. Dispose of it and replace with a new battery pack.

– Correct maintenance is essential to maintain the original efficiency and safety of the machine over time.

– Keep all nuts, bolts, and screws tight to be sure that the machine is in safe working condition.

– Never use the machine with worn or damaged parts. Damaged parts must be replaced and never repaired.

– Only use original spare parts. Parts that are not of the same quality can seriously damage the equipment and compromise safety.

– If your machine has a malfunction or is damaged or requires servicing: Contact PRORUN Customer Service.

● **Sharpening the saw chain (Fig. 28)**

It is very important for smooth and safe operation to always keep the cutters sharp.

The saw chain needs to be sharpened when:

– Sawdust becomes powder-like.

– You need extra force to saw in.

– The cut way does not go straight.

– Vibration increases.

The specifications of the chain and the bar authorized for this machine are shown in the **SPECIFICATIONS** chart within this manual. Do not use other types of chains or bars for safety reasons.

The below Figure 28 gives the sharpening data for saw chain, but this does not mean you can use different chains than the authorized one.

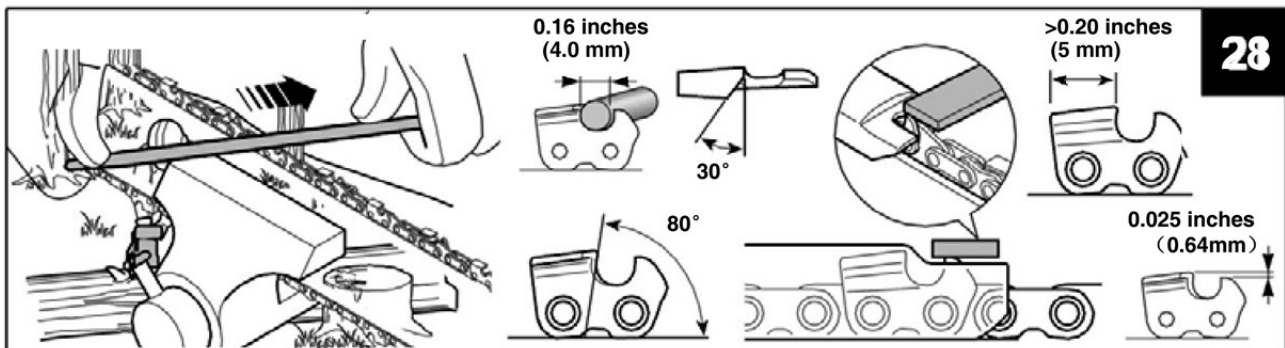

● Bar maintenance (Fig. 29)

To avoid asymmetrical wear on the bar, make sure it is turned over periodically.

To keep the bar in perfect working order, proceed as follows:

- Grease the bearings on the nose sprocket (if present) with the syringe. Clean the bar groove with the scraper.
- Clean the lubrication holes.
- Remove burrs from the edges and level off the guides with a flat file.
- Replace the bar whenever the groove is not as deep as the height of the drive links (which must never touch the bottom).
- Replace the bar when the inside of the guide is worn enough to make the chain lean to one side.

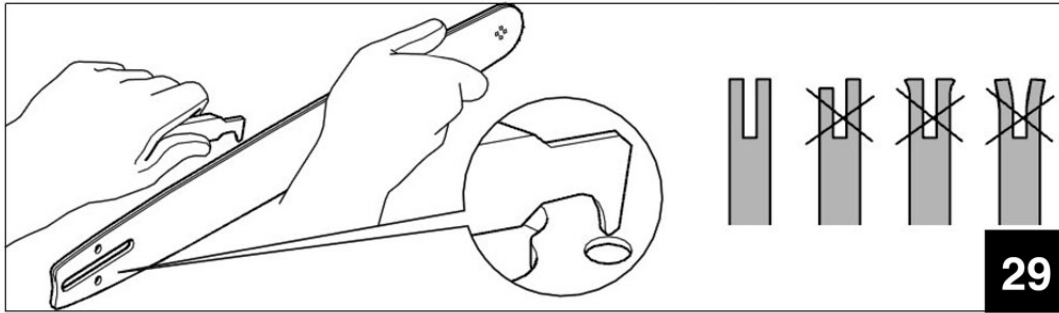

● Servicing and Repairing the Battery.

The battery requires no servicing and cannot be repaired.

- If the battery has a malfunction or is damaged: Replace the battery.

● Servicing and repairing the charger

The charger requires no servicing and cannot be repaired.

- If the charger has a malfunction or is damaged: Replace the charger.
- If the connecting cable has a malfunction or is damaged: DO NOT use the charger and contact PRORUN Customer Service.

⚠ WARNING! If the battery pack cracks or breaks, with or without leaks, do not recharge it and do not use. Dispose of it and replace with a new battery pack.

● Inspections of the chainsaw, battery, and charger

To reduce the risk of personal injury from unintended activation, remove the battery before conducting an inspection, or performing any maintenance on the chainsaw:

- Sharpen the saw chain per instructions in this user's manual.
- Use only recommended guide bar and saw chain as specified in this user's manual.
- Contact PRORUN Customer Service with questions or issues with this machine.

DO NOT ATTEMPT TO REPAIR THE BATTERY!

To avoid injury and risk of fire, explosion, or electric shock, and to avoid damage to the environment:

- Cover the battery's terminals with heavy-duty adhesive tape.
- DO NOT attempt to remove or destroy any of the battery pack components.
- DO NOT attempt to open the battery pack.
- If a leak develops, the released electrolytes are corrosive and toxic. DO NOT get the solution in the eyes or on skin, and do not swallow it.
- DO NOT place these batteries in your regular household trash.
- DO NOT incinerate.
- DO NOT place them where they will become part of any waste landfill or municipal solid waste stream.
- Take them to a certified recycling or disposal center.

● Limitations

The manufacturer disclaims any responsibility if the device has not been used for its intended

purpose or if the user has not followed the safety instructions for use.

- Read the instructions carefully before each use of the machine.
- Keep your receipt, this is necessary for a guarantee.

12. TRANSPORTING, CLEANING, AND STORING

a) When transporting or storing the chainsaw always fit the guide bar cover. Proper handling of the chainsaw will decrease the risk of personal injury from the blades.

b) Unintentional starting may result in personal injury or property damage. Remove the battery before inspecting the chainsaw or carrying out any cleaning, maintenance, or repair work, before storing, and any other time the chainsaw is not in use.

c) Improper storage can result in unauthorized use, damage to the machine, battery and charger and an increased risk of fire, electric shock, and other personal injury or property damage.

- Before storing, always unplug the charger from the wall outlet and remove the battery.
- Store the machine, battery, and charger indoors in a dry, secure place out of the reach of children and other unauthorized users.

● Transporting the chainsaw

When transporting the chainsaw:

- Switch off the chainsaw and remove the battery pack.
- Slide a guide bar cover over the guide bar so that it covers the entire saw chain.
- When transporting the chainsaw by hand, hold it by the front handle with the guide bar pointing backwards, opposite the direction in which you are walking.
- When transporting the chainsaw in a vehicle, always fit the guide bar cover. Secure and position

the chainsaw to prevent turnover, leakage, impact, and damage.

● Transporting the battery

Switch off the machine and remove the battery.

- Make sure the battery is in a safe condition.

Observe the following points when packing the battery:

- The packaging must be non-conductive.
- Make sure the battery cannot shift inside the packaging.
- Secure the packaging so that it cannot move.

● Cleaning the chainsaw

To reduce the risk of personal injury from unintended activation, remove the battery before conducting cleaning on the chainsaw:

- Clean the chainsaw's plastic components with a slightly dampened cloth. Do not use detergents or solvents.
- Do not use a pressure washer to clean the housing or spray them with water or other liquids.
- Keep the battery housing and guides free from foreign matter and clean as necessary with a soft brush or soft, dry cloth.
- Always unplug the charger before cleaning.
- Keep the charger housing and electrical contacts free from foreign matter.

● Cleaning the battery

- Clean the battery with a damp cloth.

● Cleaning the charger

- Disconnect the plug from the wall outlet.
- Clean the charger with a damp cloth.
- Clean the charger's electrical contacts with a soft brush.

● Storing the chainsaw

When storing the chainsaw:

- Switch off the chainsaw and remove the battery pack.
- Clean the chainsaw.

- Always fit the guide bar cover or remove the saw chain and guide bar.
- Store the chainsaw indoors in a dry and secure location, out of the reach of children.
- Protect the chainsaw against dampness and corrosive agents such as garden chemicals and de-icing salts.
- Keep the machine clean and dry.

● **Storing the battery**

We recommend that you store the battery with a charge between 40% and 60%.

Observe the following points when storing the battery:

- Battery is out of the reach of children.
- Battery is clean and dry.
- Battery is in an enclosed space.
- Battery is stored separately, away from the machine and charger.
- Battery is in non-conductive packaging.
- Battery is in a temperature range between 41 °F (5 °C) and 113 °F (45 °C).
- Remove foreign matter from the battery compartment and clean the battery compartment with a damp cloth.
- Clean electrical contacts in the battery compartment with a soft brush.

● **Storing the charger**

- Disconnect the charger from the wall outlet. Remove the battery from the charger.
- Store the charger indoors in a dry and secure location.
- Keep it out of the reach of children.

13. TROUBLESHOOTING

Problem	Possible cause	Solution
Motor fails to start when power switches are depressed.	Battery is not secure. Battery is not charged. Chain brake is engaged.	To secure the battery pack, make sure the latches on the top of the battery pack snap into place. Charge the battery pack according to the instructions included with your model. Pull the front handle guard towards front handle to release the chain brake.
Motor runs but saw chain does not move.	Debris or other materials may be jamming the sprocket. Sprocket worn or damage.	Remove battery, clear debris blockage from sprocket. Contact PRORUN Customer Service.
Chainsaw cuts out during operation.	Battery pack too hot. Electrical malfunction.	Allow the battery to cool down gradually at ambient temperatures. Contact PRORUN Customer Service.
Machine runtime is too short.	Battery not fully charged. Useful life of battery has been reached or exceeded.	Fully charge the battery. Contact PRORUN Customer Service for replacement.

14. DISPOSAL

 All toxic materials must be disposed of in a specified manner to prevent contamination of the environment. Before disposing of damaged or worn-out Lithium-Ion battery packs, contact your local waste disposal agency, or the local Environmental Protection Agency for information and specific instructions. Take the batteries to a local recycling and/or disposal center, certified for lithium-ion disposal .

15. EXPLODED VIEW

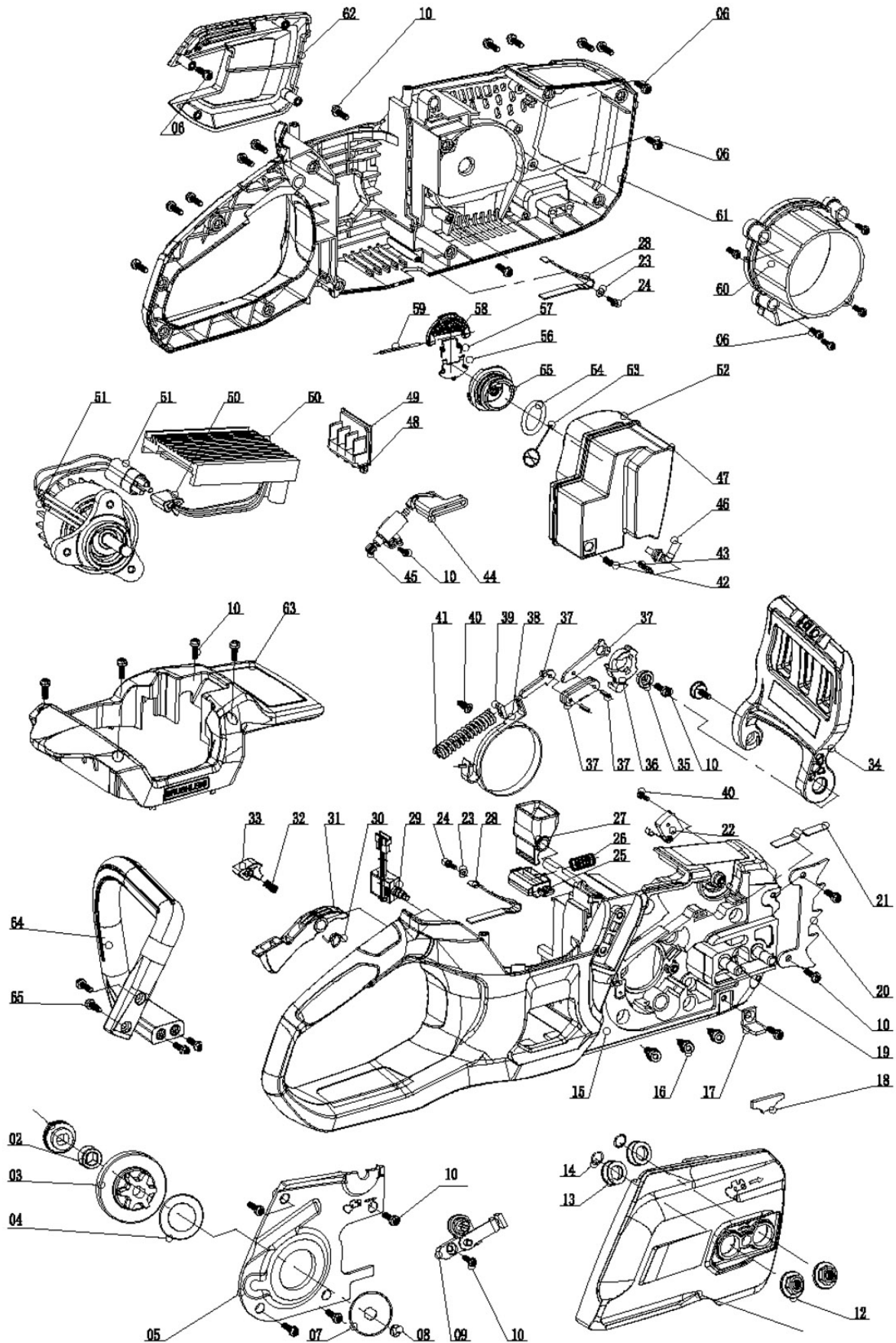

15. EXPLODED VIEW

NO.	DESCRIPTION	QTY	NO.	DESCRIPTION	QTY
1	Worm	1	27	Battery release button	1
2	Motor bush	1	28	Battery release belt spring	1
3	Drive sprocket	1	29	Power signal switch	1
4	Felt sealing	1	30	Return torsion spring	1
5	Oil pump cover	1	31	Power switch trigger	1
6	Tapping screw ST4×10	8	32	Lock-off button spring	1
7	Sprocket washer	1	33	Lock-off button	1
8	E type circlip	1	34	Chain kickback brake guard	1
9	Chain tensioner assembly	1	35	Guard bush	2
10	Tapping screw ST4×16	24	36	Chain brake ratchet	1
11	Chain sprocket cover	1	37	Chain brake gemel	4
12	Locking nuts	2	38	Chain brake strap	1
13	Bush	2	39	Chain spring base	1
14	Circle circlip	2	40	Tapping screw ST4.2×16	2
15	Right housing	1	41	Chain brake spring	1
16	Screw M5×18	3	42	Chain oil filter spring	1
17	Chain catcher	1	43	Chain oil filter	1
18	Sealing	1	44	Oil outlet tube	1
19	Bolt	1	45	Oil pump	1
20	Bumper spikes	1	46	Oil inlet tube	1
21	Guard belt spring	1	47	Oil tank bottom shell	1
22	Chain brake signal switch	1	48	Connecting terminal	4
23	Plate washer 3×7.5×0.8	2	49	Terminal base	1
24	Tapping screw ST2.9×12	2	50	Controller	1
25	Lock latch	1	51	BLDC motor	1
26	Battery release spring	2	52	Oil tank top shell	1

15. EXPLODED VIEW

NO.	DESCRIPTION	QTY	NO.	DESCRIPTION	QTY
53	Oil tank cap retainer	1			
54	O ring 24.7×3.55	1			
55	Oil tank cap	1			
56	Knob	1			
57	Torsion spring	1			
58	Panel	1			
59	Pin	1			
60	Motor housing	1			
61	Left housing	1			
62	Side cover	1			
63	Top cover	1			
64	Front handle	1			
65	Tapping screw ST5×16	4			

16. EC DECLARATION

1) Herewith we, Zhejiang Zhongjian Technology Co., Ltd.
No.155 Mingyuan North AVE, Economic Development Zone, Yongkang, Zhejiang, 321300, P.R.
China

declare that the following appliance complies with the appropriate basic safety and health requirements of the EC Directives based on its design and type, as brought into circulation by us.

This declaration relates exclusively to the machinery in the state in which it was placed on the market and excludes components which are added and/or operations carried out subsequently by the final user.

2) Designation/ function: Battery chain saw for forest work, e.g., felling, delimiting, bucking.

3) Type: PCS160H

4) Serial number: MM/YY-XXXXX

5) Applicable EC Directives: Machinery Directive 2006/42/EC

6) Used harmonized Standards: EN 62841-1:2015, EN 62841-4-1:2020

7) Additional used EC Directives: EMC Directive 2014/30/EU on electromagnetic compatibility
Noise Directive 2000/14/EC as amended by Directive 2005/88/EC on the noise emission in the environment by equipment for use outdoors
2011/65/EU as amended Directive (EU) 2015/863 Restriction of the use of certain hazardous substances in electrical and electronic equipment

8) Used other technical standards/ specifications: EN 55014-1:2017+A11:2020, EN 55014-2:2015

9) Responsible for documentation:

10) EC type approval: XXXXXXXXXX-01 Intertek Deutschland GmbH (NB 905) Stangenstraße 1, 70771 Leinfelden-Echterdingen

Measured sound power level	94.3 dB(A)
Guaranteed sound power level	97 dB(A)
Conformity assessment method to Annex V/ Directive 2000/14/EC and 2005/88/EC	

11) Date /Place/Name/ Authorized Signature:
2022-02-12/ Yongkang/ Yang Haiyue

12) Title of Signatory:
Chief Engineer

PRORUN regularly improves our products, and you may find slight differences between your machine and descriptions contained within this operator's manual. Modifications can be made to the machine without notice and without the obligation to update the manual, providing that the essential safety and functional characteristics remain unaltered. Contact PRORUN Customer Service with any questions and for current specifications.

PRORUN / TOPSUN USA
200 Overhill Drive, Suite A
Mooresville, NC 28117
Proruntech.com
info@proruntech.com
Phone: 1-844-905-0882



Zhejiang Zhongjian Technology Co., Ltd
Web: www.topsunpower.cc
E-mail: sales@topsunpower.cc
ADD: No.155 Mingyuan North AVE, Economic Development Zone,
Yongkang, Zhejiang, 321300, P.R.China
Made In China