



Through-The-Wall Air Conditioners

TTW Wall Sleeve (Optional)

Wall sleeves simplify installing an air conditioner in your wall so that you don't have to balance the heavy window unit during installation.

Wall Sleeve Model: KSTSLV1

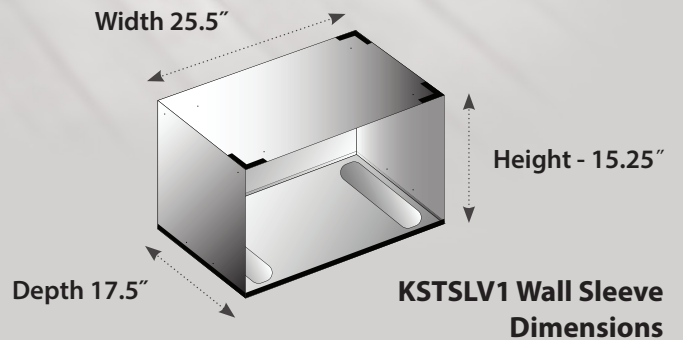

Standard Features



Sleep Mode



Auto Restart Function



Timer



Healthy Filters



Self Evaporative System



Follow Me Remote

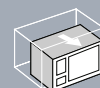

Sliding Chasis

Optional Feature



Auxiliary Electric Heater

Through-The-Wall Air Conditioners (Cool Only)

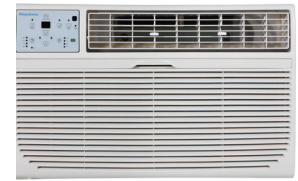

Model No.	KSTAT08-1D	KSTAT10-1D	KSTAT10-2D	KSTAT12-1D	KSTAT12-2D	KSTAT14-2D
Power Supply	115V / 60Hz	115V / 60Hz	230V / 60Hz	115V / 60Hz	230V / 60Hz	230V / 60Hz
Cooling Capacity	8,000 BTU/h	10,000 BTU/h	10,000 BTU/h	12,000 BTU/h	12,000 BTU/h	14,000 BTU/h
Heating Pump	-	-	-	-	-	-
Power Input - Cooling	754 W	943 W	943 W	1142 W	1142 W	1515 W
Power Input - Heating	-	-	-	-	-	-
Cooling Amps	7.0 A	8.3 A	4.5 A	10.0 A	5.2 A	6.9 A
EER	10.6	10.6	10.6	10.5	10.5	9.3
Energy Star	Yes	Yes	Yes	Yes	Yes	No
Indoor Noise Level dBA	56.8 / 51.8	57.4 / 53.1	58.4 / 54.1	60.5 / 56.5	60.5 / 56.5	61.3
Air Flow Volume - CFM	270	269	275	286	286	296
Cooling Area	350 sq. ft.	450 sq. ft.	450 sq. ft.	550 sq. ft.	550 sq. ft.	700 sq. ft.
Cooling Speeds	3	3	3	3	3	3
Fan Speeds	3	3	3	3	3	3
Net Dimensions (in.) W x D x H	24.2" x 20.3" x 14.5"	24.2" x 20.3" x 14.5"	24.2" x 20.3" x 14.5"	24.2" x 20.3" x 14.5"	24.2" x 20.3" x 14.5"	24.2" x 20.3" x 14.5"
Net Weight	65 lbs.	68 lbs.	69 lbs.	76 lbs.	78 lbs.	79 lbs.
Included Accessories	remote control, 2 AAA batteries, mesh filter	remote control, 2 AAA batteries, mesh filter	remote control, 2 AAA batteries, mesh filter	remote control, 2 AAA batteries, mesh filter	remote control, 2 AAA batteries, mesh filter	remote control, 2 AAA batteries, mesh filter

Through-The-Wall Air Conditioners (with Heat)

Model No.	KSTAT08-1HD	KSTAT10-2HD	KSTAT12-2HD	KSTAT14-2HD
Power Supply	115V / 60Hz	230V / 60Hz	230V / 60Hz	230V / 60Hz
Cooling Capacity	8,000 BTU/h	10,000 BTU/h	12,000 BTU/h	14,000 BTU/h
Heating Pump	4,200 BTU/h	10,600 BTU/h	10,600 BTU/h	10,600 BTU/h
Power Input - Cooling	825 W	1020 W	1220 W	1515 W
Power Input - Heating	1380 W	3450 W	3450 W	3450 W
Cooling Amps	7.8 A	4.6 A	5.5 A	6.9 A
Heating Amps	12 A	15 A	15 A	15 A
EER	9.6	9.6	9.5	9.3
Energy Star	No	No	No	No
Indoor Noise Level dBA	57	58	61.5	61.5
Air Flow Volume - CFM	288	287	300	300
Cooling Area	350 sq. ft.	450 sq. ft.	550 sq. ft.	700 sq. ft.
Cooling Speeds	3	3	3	3
Fan Speeds	3	3	3	3
Net Dimensions (in.) W x D x H	24.2" x 20.3" x 14.5"	24.2" x 20.3" x 14.5"	24.2" x 20.3" x 14.5"	24.2" x 20.3" x 14.5"
Net Weight	65 lbs.	74 lbs.	78 lbs.	80 lbs.
Included Accessories	remote control, 2 AAA batteries, mesh filter	remote control, 2 AAA batteries, mesh filter	remote control, 2 AAA batteries, mesh filter	remote control, 2 AAA batteries, mesh filter

Keystone Accessories



Follow Me Remote Control
(included)



KSTSLV1: Optional Wall Sleeve
(Sold Separately)