

READ THIS FIRST

Model W1756/W1757
*****IMPORTANT UPDATE*****
Applies to Models Mfd. Since 02/22
and Owner's Manual Printed 08/07



Phone #: (360) 734-3482 • Tech Support: techsupport@woodstockint.com • Web: www.woodstockint.com

We made the following change to this machine since the manual was printed:

- The upper frame cover now has 5" dust ports welded to it.

Aside from the information contained in this update, all other content in the owner's manual is applicable and **MUST** be read and understood for your own safety.

IMPORTANT: Keep this update with the owner's manual for future reference. If you have any further questions, contact our Technical Support.

W1756 Revised Specifications

Product Dimensions

Height 65 in.

Shipping Dimensions

Height 77 in.

Main Specifications

Other Related Information

Number of Dust Ports..... 4
Dust Port Size5 in.

W1757 Revised Specifications

Product Dimensions

Height 68 in.

Shipping Dimensions

Height 79 in.

Main Specifications

Other Related Information

Number of Dust Ports..... 8
Dust Port Size5 in.



COPYRIGHT © JANUARY, 2022 BY WOODSTOCK INTERNATIONAL, INC., REVISED MARCH, 2022 (CS)

WARNING: NO PORTION OF THIS MANUAL MAY BE REPRODUCED IN ANY SHAPE OR FORM WITHOUT

THE WRITTEN APPROVAL OF WOODSTOCK INTERNATIONAL, INC.

#22221CS Printed in Taiwan

W1756 New Frame Cover & Dust Ports

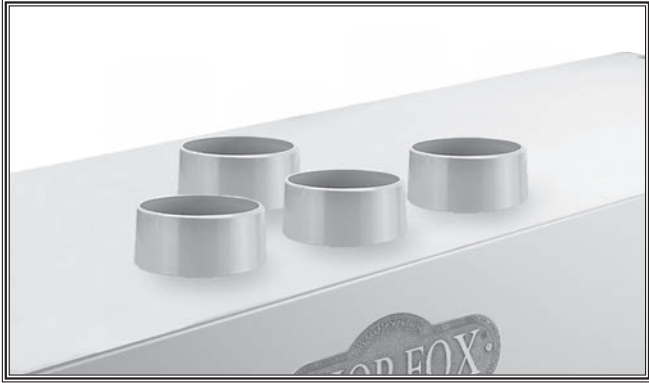

W1757 New Frame Cover & Dust Ports

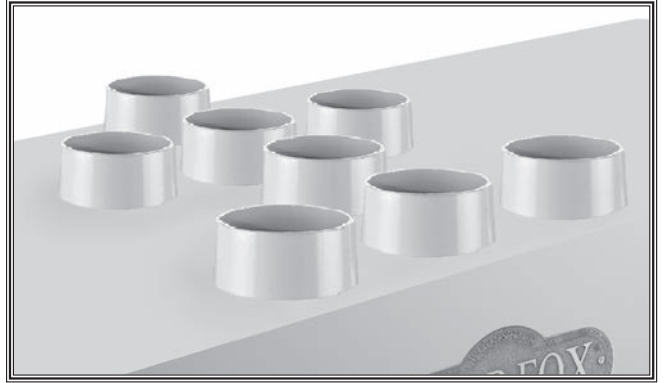

W1756 Old Frame Cover & Dust Ports

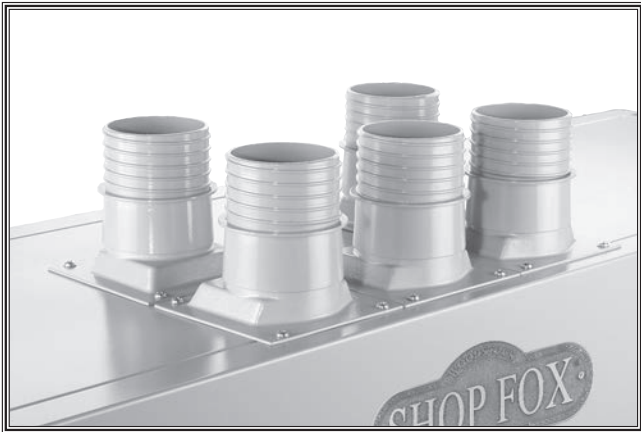

W1757 Old Frame Cover & Dust Ports

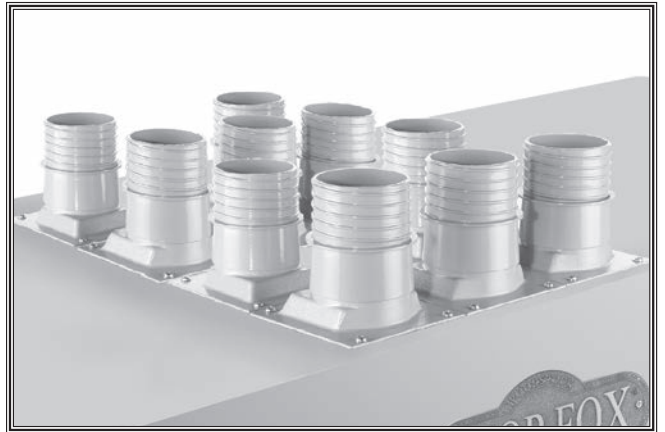

W1756 Revised Parts

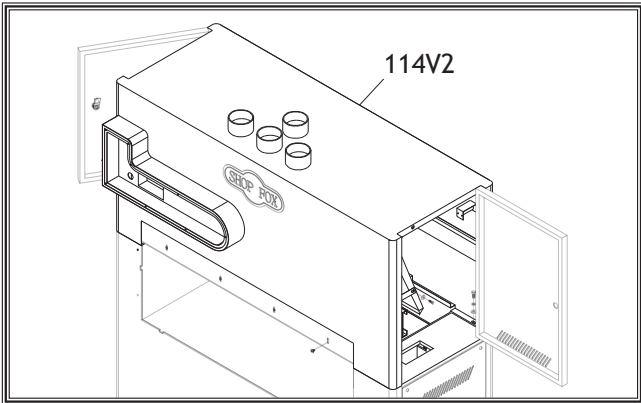

W1757 Revised Parts

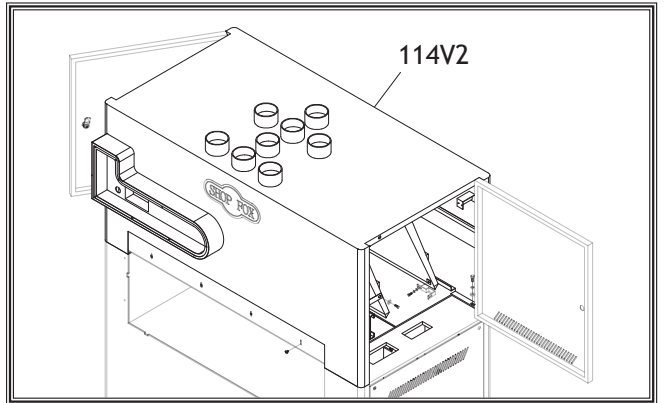

REF	PART #	DESCRIPTION
114V2	X1756114V2	UPPER FRAME COVER V2.02.22

REF	PART #	DESCRIPTION
114V2	X1757114V2	UPPER FRAME COVER V2.02.22

SETUP

Unpacking

This machine has been carefully packaged for safe transportation. If you notice the machine has been damaged during shipping, please contact your authorized Shop Fox dealer immediately.

Inventory

The following is a list of items shipped with your machine. Before beginning setup, lay these items out and inventory them.

Note: *If you cannot find an item on this list, carefully check around/inside the machine and packaging materials. Often, these items get lost in packaging materials while unpacking or they are pre-installed at the factory.*

Inventory (Figure 7)	Qty
A. Sanding Belts 100-Grit, 180-Grit	1 Ea.
B. Platen Graphite Flaps.....	2
C. Spare Fuses 4A (Inside Electrical Box)	2
D. Tool Box	1
– Phillips Head Screwdriver #2.....	1
– Flat Head Screwdriver 1/4"	1
– Open-End Wrenches 8/10, 12/14, 17/19mm ..	1 Ea.
– Metric Hex Wrench Set 1.5-10mm (10-Pc).....	1
– Door Keys	2
– Ceramic Limit Switch Rub Rods	2
– Flexible Grease Gun Extension	1
– Platen Removal Tool.....	1
E. Platen Felt.....	1



⚠ WARNING

This machine presents serious injury hazards to untrained users. Read through this entire manual to become familiar with the controls and operations before starting the machine!



⚠ WARNING

Wear safety glasses during entire setup process!

⚠ WARNING



HEAVY LIFT!

Straining or crushing injury may occur from improperly lifting machine or some of its parts. To reduce this risk, get help from other people and use a forklift (or other lifting equipment) rated for weight of this machine.

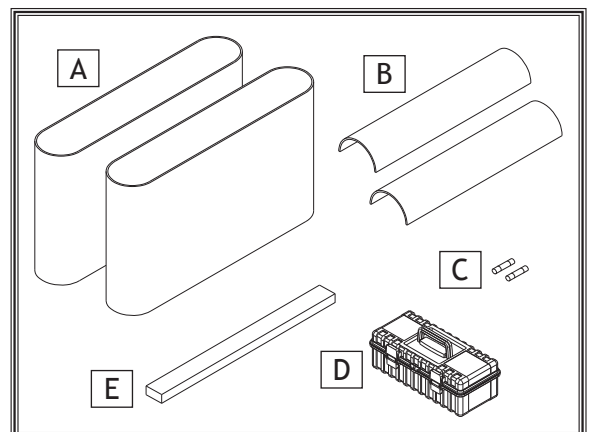

Figure 7. Inventory.

Air Hose

To install air line, do these steps:

1. Connect air inlet on regulator (**Figure 8**) to compressed air line.
2. Make sure ON/OFF handle on regulator is in open position.
3. Lift regulator knob (**Figures 8-9**) and rotate it until gauge reads 75 PSI.

Note: Rotate knob clockwise to increase air pressure and counterclockwise to lower air pressure.

4. Push knob down until it snaps to lock it.

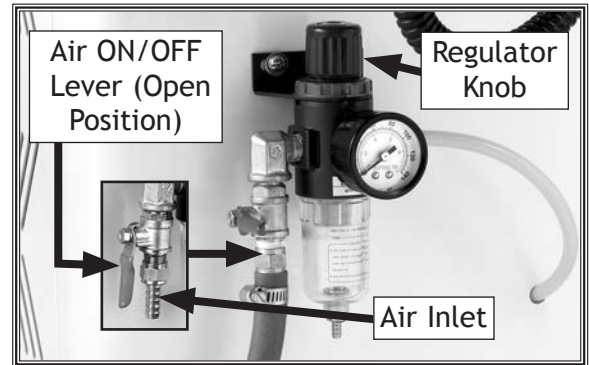

Figure 8. Air hose attached to regulator.

Dust Collection

W1756 Recommended CFM at Dust Ports: ... 2400 CFM

W1757 Recommended CFM at Dust Ports: ... 4800 CFM

Do not confuse this CFM recommendation with the rating of the dust collector. To determine the CFM at the dust port, you must consider these variables: (1) CFM rating of the dust collector, (2) hose type and length between the dust collector and the machine, (3) number of branches or wyes, and (4) amount of other open lines throughout the system. Explaining how to calculate these variables is beyond the scope of this manual. Consult an expert or purchase a good dust collection “how-to” book.

Items Needed	Qty
Dust Collection System	1
Dust Hoses 5"	4 for W1756, 8 for W1757
Hose Clamps 5"	4 for W1756, 8 for W1757

To connect dust collection hoses, do these steps:

1. Fit dust hoses over dust ports, as shown in **Figure 10**, and secure them in place with hose clamps.
2. Tug hoses to make sure they do not come off.

Note: A tight fit is necessary for proper performance.

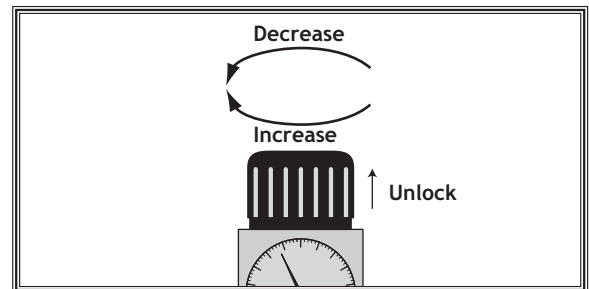

Figure 9. Regulator knob.

⚠ CAUTION

This machine creates substantial amounts of dust during operation. Breathing airborne dust on a regular basis can result in permanent respiratory illness. Reduce your risk by wearing a respirator and capturing the dust with a dust collection system.

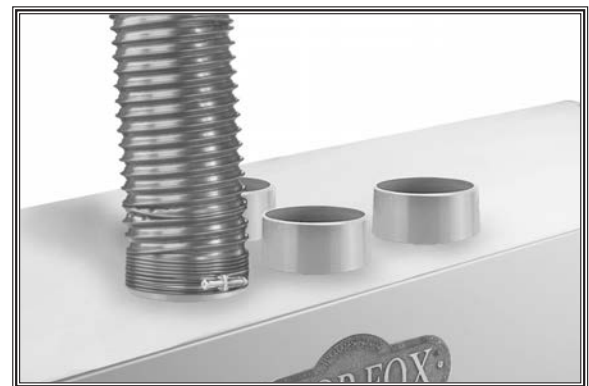

Figure 10. Example of hose attached to port (W1756 shown).

READ THIS FIRST

Model W1756/W1757 ***IMPORTANT UPDATE***

Applies to Models Mfd. Since 1/14
and Owner's Manual Printed 8/07

Phone #: (360) 734-3482 • Tech Support: tech-support@shopfox.biz • Web: www.shopfox.biz



We made the following changes to this machine since the manual was printed:

- Obtained CSA certification meeting CSA C22.2 #105-1953 and UL 987-7th standards.
- Changed electrical cabinet transformer, terminal bar/plate, fuses, and sanding motor contactor.
- Changed descriptions of electrical cabinet overload relays.
- Updated safety and electrical information.
- Changed machine wiring.
- Replaced oscillation diaphragm assembly (P/N 567) with an air cylinder (P/N 567V2).

Note: At the top of each page is a note that indicates which page it replaces or adds to in the original manual. On the parts list, the new parts are designated with a "V2".

Aside from the information contained in this update, all other content in the owner's manual **MUST** be read and understood for your own safety. **IMPORTANT:** Keep this update with the owner's manual for future reference. If you have any further questions, contact our Technical Support.

Changed Electrical Cabinet Components (Changes to Page 57)

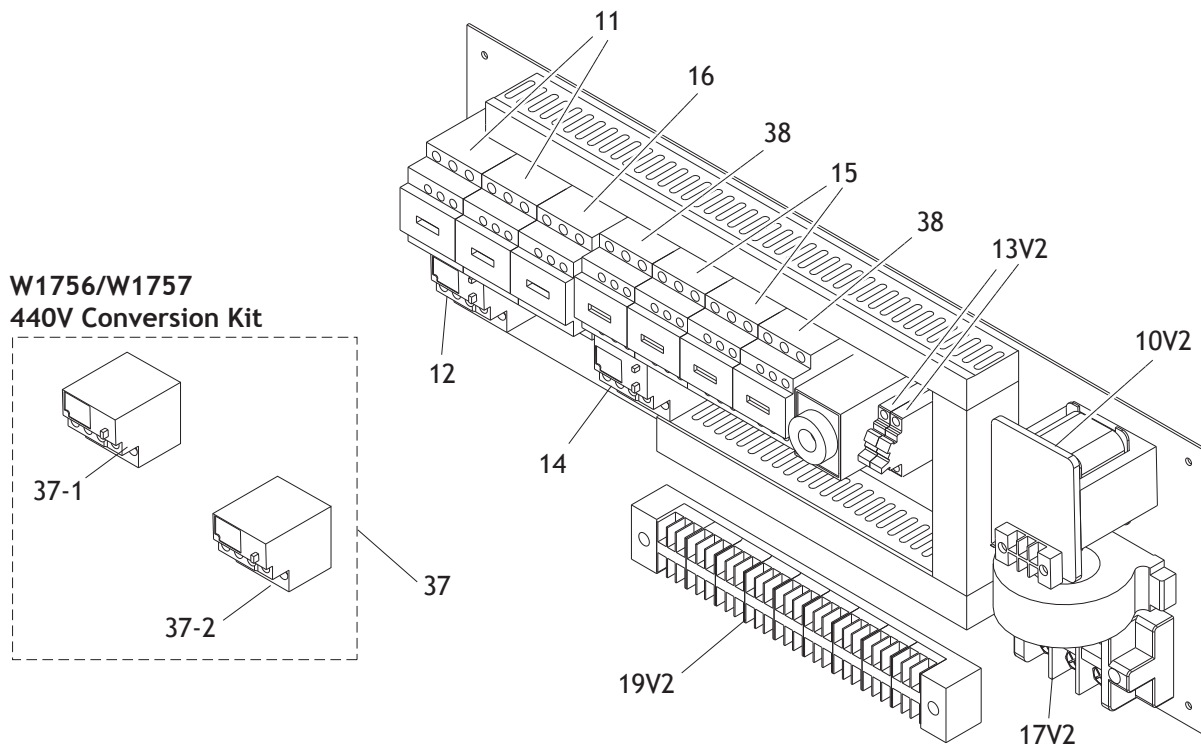

COPYRIGHT © JANUARY, 2016 BY WOODSTOCK INTERNATIONAL, INC.

WARNING: NO PORTION OF THIS MANUAL MAY BE REPRODUCED IN ANY SHAPE OR FORM WITHOUT

THE WRITTEN APPROVAL OF WOODSTOCK INTERNATIONAL, INC #16610TS Printed in Taiwan

Changed Electrical Cabinet Component Parts List (Changes to Page 58)

REF	PART #	DESCRIPTION
10V2	X1756010V2	TRANSFORMER SUENLIANG SPTBS20250 V2.10.12
11	X1756011	CONTACTOR SCHN LC1D38 220V
12	X1756012	OL RELAY SCHN LR3D35 30-38A
13V2	X1756013V2	FUSE 4A 10.3 X 38 W/HOLDER V2.10.12
14	X1756014	OL RELAY SCHN LR3D12 5.5-8A
15	X1756015	CONTACTOR SCHN LC1D09 220V W/LOCK
16	X1756016	CONTACTOR SCHN LC1D25 220V
17V2	X1756017V2	TERMINAL PLATE V2.10.12
19V2	X1756019V2	TERMINAL BAR V2.10.12
38	X1756038	CONTACTOR SCHN LC1D09 220V

W1756/W1757 440V Conversion Kit

37	X1756037	440V CONVERSION KIT
37-1	X1756037-1	OL RELAY SCHN LR3D21 12-18A
37-2	X1756037-2	OL RELAY SCHN LR3D08 2.5-4A

SAFETY

For Your Own Safety, Read Manual Before Operating Machine

The purpose of safety symbols is to attract your attention to possible hazardous conditions. This manual uses a series of symbols and signal words intended to convey the level of importance of the safety messages. The progression of symbols is described below. Remember that safety messages by themselves do not eliminate danger and are not a substitute for proper accident prevention measures—this responsibility is ultimately up to the operator!



Indicates an imminently hazardous situation which, if not avoided, **WILL** result in death or serious injury.



Indicates a potentially hazardous situation which, if not avoided, **COULD** result in death or serious injury.



Indicates a potentially hazardous situation which, if not avoided, **MAY** result in minor or moderate injury.

NOTICE

This symbol is used to alert the user to useful information about proper operation of the equipment or a situation that may cause damage to the machinery.

Standard Machinery Safety Instructions

OWNER'S MANUAL. Read and understand this owner's manual **BEFORE** using machine.

TRAINED OPERATORS ONLY. Untrained operators have a higher risk of being hurt or killed. Only allow trained/supervised people to use this machine. When machine is not being used, disconnect power, remove switch keys, or lock-out machine to prevent unauthorized use—especially around children. Make workshop kid proof!

DANGEROUS ENVIRONMENTS. Do not use machinery in areas that are wet, cluttered, or have poor lighting. Operating machinery in these areas greatly increases the risk of accidents and injury.

MENTAL ALERTNESS REQUIRED. Full mental alertness is required for safe operation of machinery. Never operate under the influence of drugs or alcohol, when tired, or when distracted.

ELECTRICAL EQUIPMENT INJURY RISKS. You can be shocked, burned, or killed by touching live electrical components or improperly grounded machinery. To reduce this risk, only allow an electrician or qualified service personnel to do electrical installation or repair work, and always disconnect power before accessing or exposing electrical equipment.

DISCONNECT POWER FIRST. Always disconnect machine from power supply **BEFORE** making adjustments, changing tooling, or servicing machine. This eliminates the risk of injury from unintended startup or contact with live electrical components.

EYE PROTECTION. Always wear ANSI-approved safety glasses or a face shield when operating or observing machinery to reduce the risk of eye injury or blindness from flying particles. Everyday eyeglasses are not approved safety glasses.

WEARING PROPER APPAREL. Do not wear clothing, apparel, or jewelry that can become entangled in moving parts. Always tie back or cover long hair. Wear non-slip footwear to avoid accidental slips, which could cause loss of workpiece control.

HAZARDOUS DUST. Dust created while using machinery may cause cancer, birth defects, or long-term respiratory damage. Be aware of dust hazards associated with each workpiece material, and always wear a NIOSH-approved respirator to reduce your risk.

HEARING PROTECTION. Always wear hearing protection when operating or observing loud machinery. Extended exposure to this noise without hearing protection can cause permanent hearing loss.

REMOVE ADJUSTING TOOLS. Tools left on machinery can become dangerous projectiles upon startup. Never leave chuck keys, wrenches, or any other tools on machine. Always verify removal before starting!

INTENDED USAGE. Only use machine for its intended purpose—never make modifications without prior approval from Woodstock International. Modifying machine or using it differently than intended will void the warranty and may result in malfunction or mechanical failure that leads to serious personal injury or death!

AWKWARD POSITIONS. Keep proper footing and balance at all times when operating machine. Do not overreach! Avoid awkward hand positions that make workpiece control difficult or increase the risk of accidental injury.

CHILDREN & BYSTANDERS. Keep children and bystanders at a safe distance from the work area. Stop using machine if they become a distraction.

GUARDS & COVERS. Guards and covers reduce accidental contact with moving parts or flying debris—make sure they are properly installed, undamaged, and working correctly.

FORCING MACHINERY. Do not force machine. It will do the job safer and better at the rate for which it was designed.

NEVER STAND ON MACHINE. Serious injury may occur if machine is tipped or if the cutting tool is unintentionally contacted.

STABLE MACHINE. Unexpected movement during operation greatly increases risk of injury or loss of control. Before starting, verify machine is stable and mobile base (if used) is locked.

USE RECOMMENDED ACCESSORIES. Consult this owner's manual or the manufacturer for recommended accessories. Using improper accessories will increase risk of serious injury.

UNATTENDED OPERATION. To reduce the risk of accidental injury, turn machine **OFF** and ensure all moving parts completely stop before walking away. Never leave machine running while unattended.

MAINTAIN WITH CARE. Follow all maintenance instructions and lubrication schedules to keep machine in good working condition. A machine that is improperly maintained could malfunction, leading to serious personal injury or death.

CHECK DAMAGED PARTS. Regularly inspect machine for any condition that may affect safe operation. Immediately repair or replace damaged or mis-adjusted parts before operating machine.

MAINTAIN POWER CORDS. When disconnecting cord-connected machines from power, grab and pull the plug—NOT the cord. Pulling the cord may damage the wires inside, resulting in a short. Do not handle cord/plug with wet hands. Avoid cord damage by keeping it away from heated surfaces, high traffic areas, harsh chemicals, and wet/damp locations.

EXPERIENCING DIFFICULTIES. If at any time you experience difficulties performing the intended operation, stop using the machine! Contact Technical Support at (360) 734-3482.

Additional Safety for Wide Belt Sanders

WARNING

Serious injury or death can occur from hands getting trapped between workpiece and conveyor table, getting entangled in rotating parts inside machine, or lacerated by sanding drum. Workpieces thrown by sander can strike nearby operators. Long-term respiratory damage can occur from using sander without proper use of a respirator and an adequate dust collection system. To minimize risk of getting hurt or killed, anyone operating machine **MUST** completely heed hazards and warnings below.

FEEDING WORKPIECE. DO NOT place fingers under bottom of workpiece while feeding it into sander. Fingers can become pinched between workpiece and conveyor.

ENTANGLEMENT HAZARDS. DO NOT wear loose clothing, gloves, or jewelry, and tie back long hair. Never reach inside operating machine or try clearing jammed workpiece. Keep all guards in place and secure, and all doors closed.

SANDING DRUM CONTACT. Rotating sandpaper can remove a large amount of flesh in a few seconds. Keep hands away from rotating sanding drum(s) during operation. Never touch moving sandpaper on purpose.

WORKPIECE KICKBACK. A workpiece can be ejected out the front of sander at high rate of speed, and hit operator or bystanders. Never stand in-line with workpiece, never feed more than one workpiece at a time, and always adjust pressure rollers below sanding roller.

MINIMUM STOCK DIMENSION. To avoid kickback, never sand workpieces below minimum specifications listed in **Data Sheet**.

ADJUSTMENTS/MAINTENANCE. Make sure machine is turned **OFF**, disconnected from power and air, and all moving parts are completely stopped before doing adjustments or maintenance.

SANDING DUST. Sanding creates large amounts of dust and flying chips that can lead to eye injury or respiratory illness. Reduce risk of these hazards by wearing approved eye and respiratory protection when using sander.

DUST COLLECTION. Never operate without adequate dust collection system in place and running. Proper dust collection reduces dust in work area, which decreases risk of long-term respiratory damage, but it is not a substitute for using a respirator.

ELECTRICAL

Availability

Before installing the machine, consider the availability and proximity of the required power supply circuit. If an existing circuit does not meet the requirements for this machine, a new circuit must be installed. To minimize the risk of electrocution, fire, or equipment damage, installation work and electrical wiring must be done by a qualified electrician in accordance with all applicable codes and standards.

Full-Load Current Rating

The full-load current rating is the amperage a machine draws at 100% of the rated output power. On machines with multiple motors, this is the amperage drawn by the largest motor or sum of all motors and electrical devices that might operate at one time during normal operations.

W1756 Full-Load Current Rating at 230V 54 Amps

W1756 Full-Load Current Rating at 460V 27 Amps

W1757 Full-Load Current Rating at 230V 66 Amps

W1757 Full-Load Current Rating at 460V 33 Amps

The full-load current is not the maximum amount of amps that the machine will draw. If the machine is overloaded, it will draw additional amps beyond the full-load rating.

If the machine is overloaded for a sufficient length of time, damage, overheating, or fire may result—especially if connected to an undersized circuit. To reduce the risk of these hazards, avoid overloading the machine during operation and make sure it is connected to a power supply circuit that meets the requirements in the following section.

Circuit Information

A power supply circuit includes all electrical equipment between the breaker box or fuse panel in the building and the machine. The power supply circuit used for this machine must be sized to safely handle the full-load current drawn from the machine for an extended period of time. (If this machine is connected to a circuit protected by fuses, use a time delay fuse marked D.)





W1756 Circuit Requirements for 230V

This machine is prewired to operate on a power supply circuit that has a verified ground and meets the following requirements:

Nominal Voltage..... 220V, 230V, 240V
 Cycle.....60 Hz
 Phase 3-Phase
 Circuit Rating 70 Amps

W1756 Circuit Requirements for 460V

This machine can be converted to operate on a power supply circuit that has a verified ground and meets the requirements listed below. (Refer to Voltage Conversion instructions for details.)

Nominal Voltage..... 440V, 460V, 480V
 Cycle.....60 Hz
 Phase 3-Phase
 Minimum Circuit Size 40 Amps

W1757 Circuit Requirements for 230V

This machine is prewired to operate on a power supply circuit that has a verified ground and meets the following requirements:

Nominal Voltage..... 220V, 230V, 240V
 Cycle.....60 Hz
 Phase 3-Phase
 Minimum Circuit Size 90 Amps

W1757 Circuit Requirements for 460V

This machine can be converted to operate on a power supply circuit that has a verified ground and meets the requirements listed below. (Refer to Voltage Conversion instructions for details.)

Nominal Voltage..... 440V, 460V, 480V
 Cycle.....60 Hz
 Phase 3-Phase
 Minimum Circuit Size 50 Amps

This machine must be permanently connected to the power supply for 460V operation. A disconnecting means, such as a locking switch (see the figure to the right), must be provided to allow the machine to be disconnected (isolated) from the power supply when required. This installation must be performed by a qualified electrician in accordance with all applicable electrical codes and ordinances.

Grounding Instructions

This machine must be grounded! In the event of a malfunction or breakdown, grounding provides a path of least resistance for electrical current to reduce the risk of electric shock. A permanently connect machine must be connected to a grounded metal permanent wiring system; or to a system having an equipment-grounding conductor. All grounds must be verified and rated for the electrical requirements of the machine. Improper grounding can increase the risk of electric shock!

Note: The circuit requirements listed in this manual apply to a dedicated circuit—where only one machine will be running at a time. If this machine will be connected to a shared circuit where multiple machines will be running at the same time, consult a qualified electrician to ensure that the circuit is properly sized for safe operation.

⚠ WARNING

Serious injury could occur if you connect the machine to power before completing the setup process. **DO NOT** connect to power until instructed later in this manual.

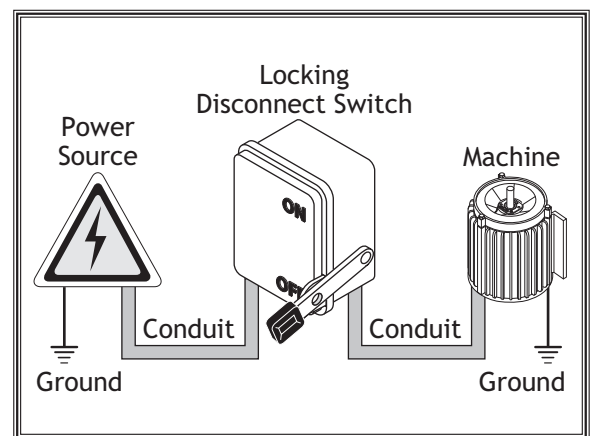

Figure 1. Typical setup of a permanently connected machine.

Extension Cords

Since this machine must be permanently connected to the power supply, an extension cord cannot be used.

460V Conversion

This machine is prewired for 230V 3-phase power but has the capability of operating on 460V power with a minor conversion. The conversion consists of replacing two overload relays and rewiring each of the three motors.

All wiring changes must be inspected by a qualified electrician or service personnel before the machine is connected to the power source.

Contact your local Shop Fox dealer to purchase the 440V conversion kit (P/N X1756037) that includes the necessary two overload relays.

To convert machine to 460V operation, do these steps:

1. DISCONNECT SANDER FROM POWER!
2. Open electrical box located on back of machine.
3. On transformer, remove wire connected to 220V terminal, and connect it to 440V terminal, as shown in **Figure 5** and in the illustrations on **Page 54**.
4. Refer to **Figure 6** and open main wiring box on your machine.
5. Swap out the applicable overload relays at the locations shown in **Figure 6** or in the photo on **Page 54**, and set them to 16A and 3A.
6. Wire sanding belt, feed belt, and table elevation motors as shown in **Motor and Transformer Connections** diagrams on **Page 54** in the owner's manual.

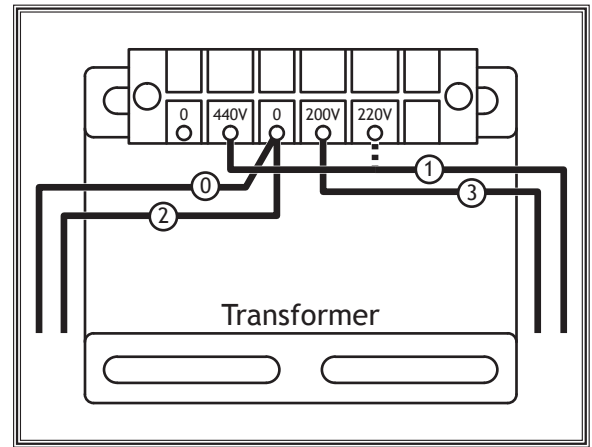

Figure 5. Rewiring transformer from 220V to 440V.

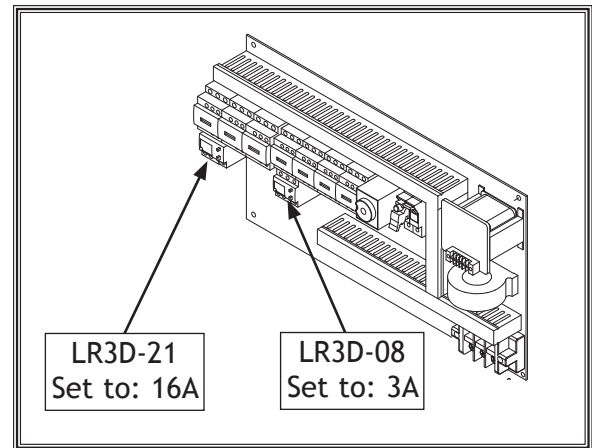
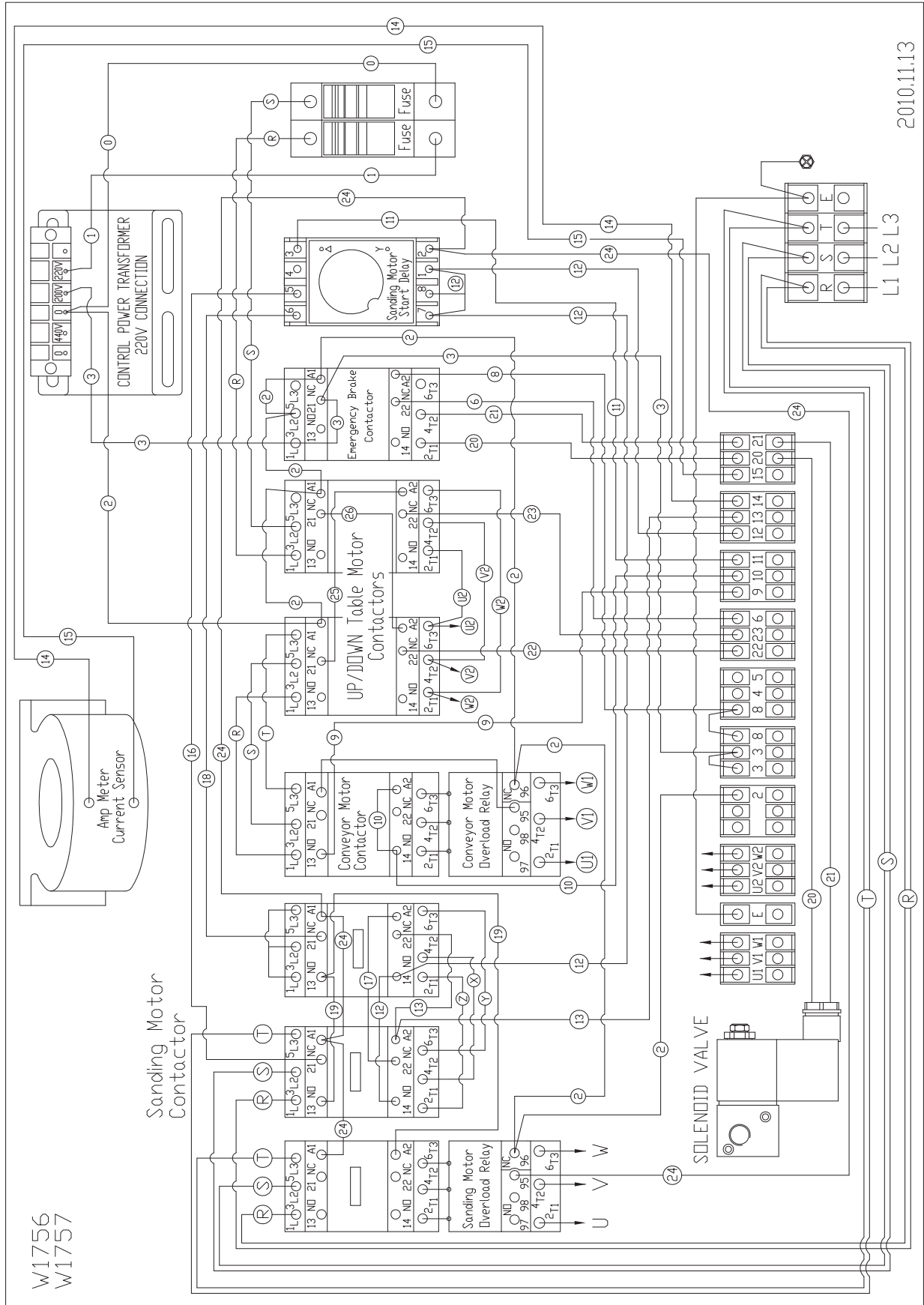
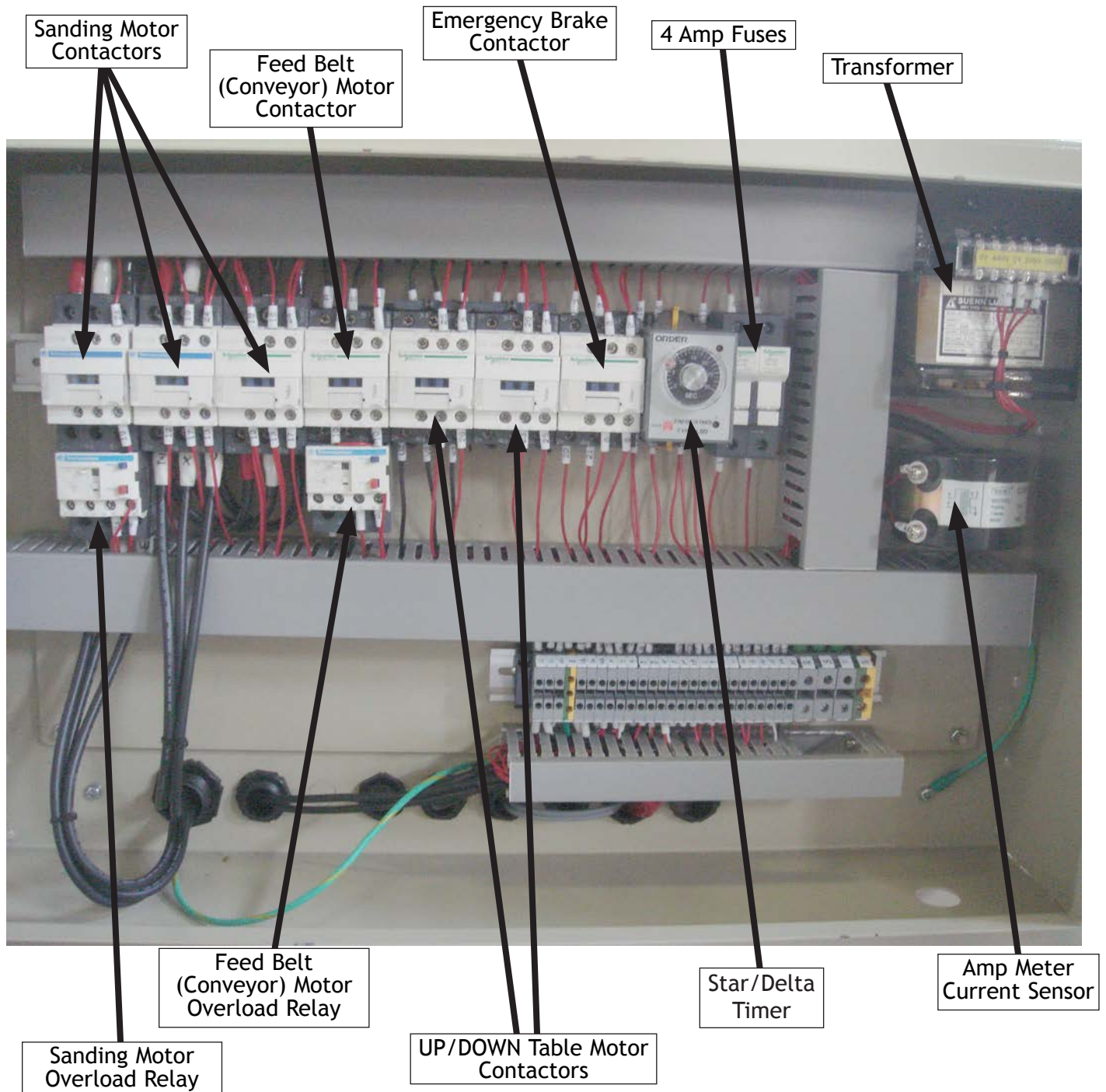

Figure 6. Overload relays.

Electrical Cabinet Wiring



Electrical Cabinet Components



Electrical Wiring Overview (W1756)

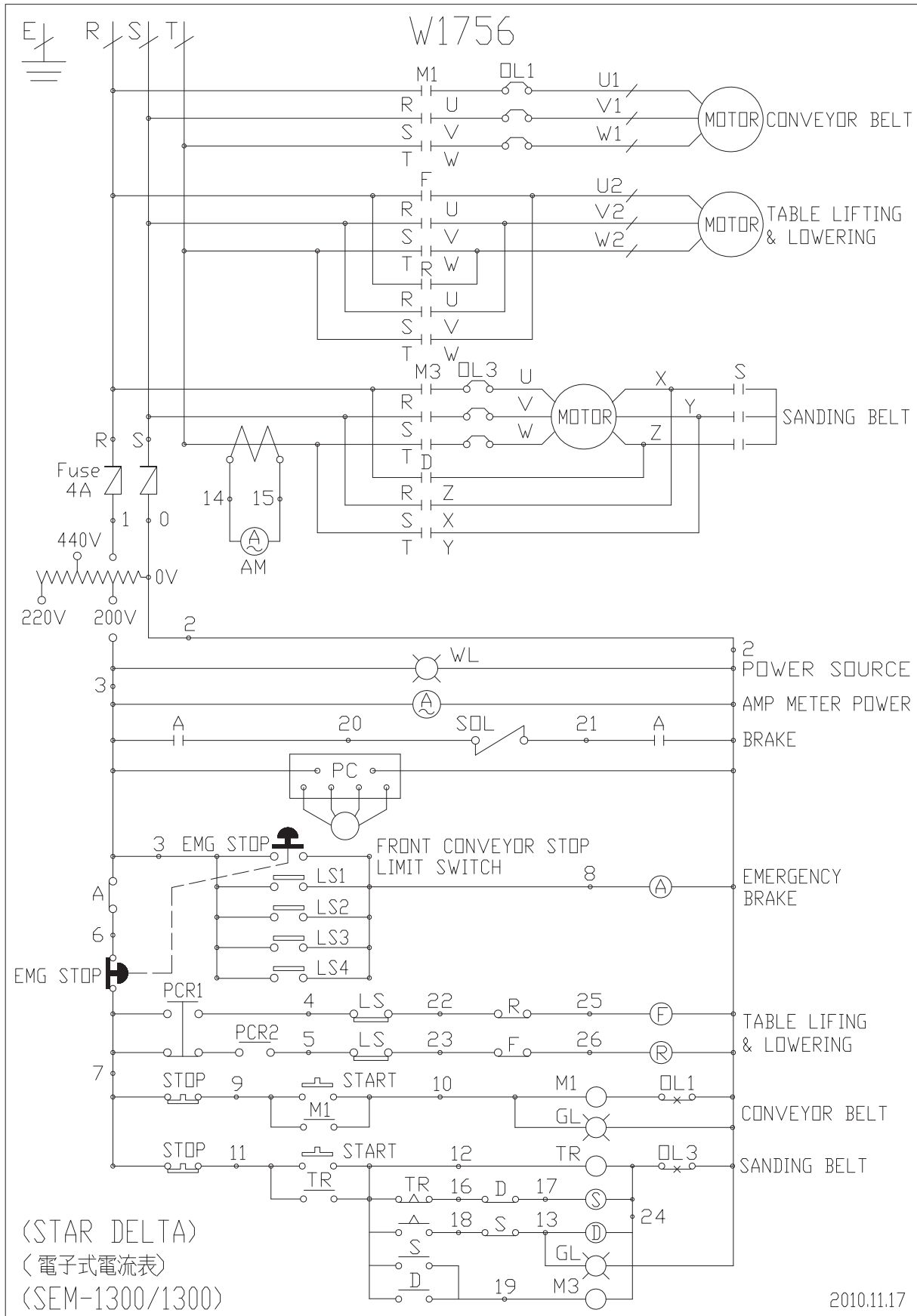

Electrical Wiring Overview (W1757)

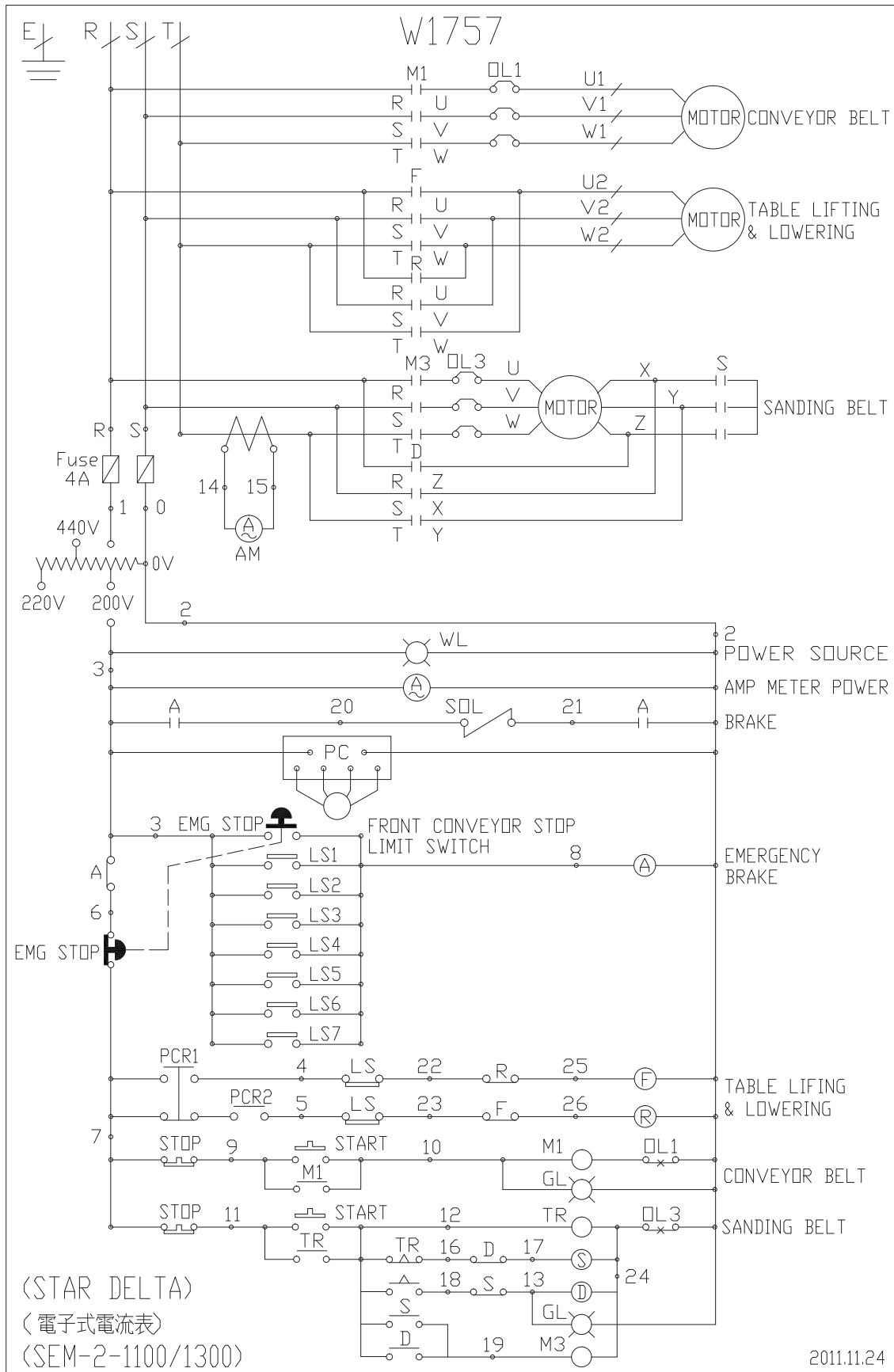

Motor and Transformer Connection

W1756/W1757 220V Three-Phase Motor/Transformer Connection †

† Power Supply Phase Converter Installation May Be Required—Consult Your Electrician.

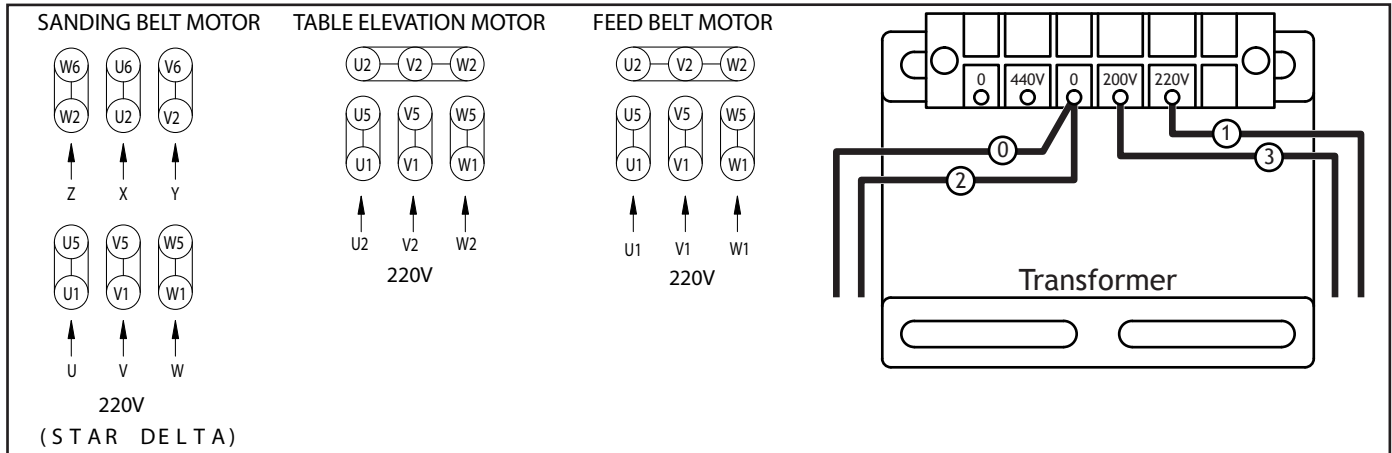

W1756/W1757 440V Three-Phase Motor/Transformer Connection ††

†† Thermal Overload Relay Replacement Required—Consult Your Electrician.

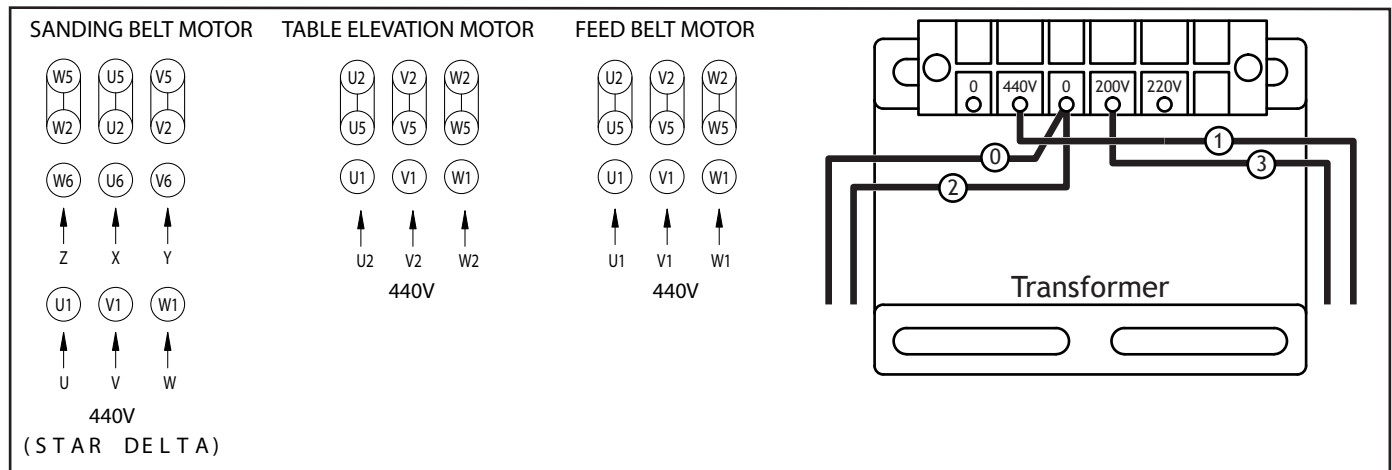

Rewiring W1756 and W1757 for 440V:

1. DISCONNECT POWER, remove the LR3D35 overload relay, and replace it with an LR3D21 type (Model W1756/W1757 Part #X1756037-1), and set the dial to 16A.
2. Remove the LR3D12 overload relay, and replace it with an LR3D08 type (Model W1756/W1757, Part # X1756037-2), and set the dial to 3A.

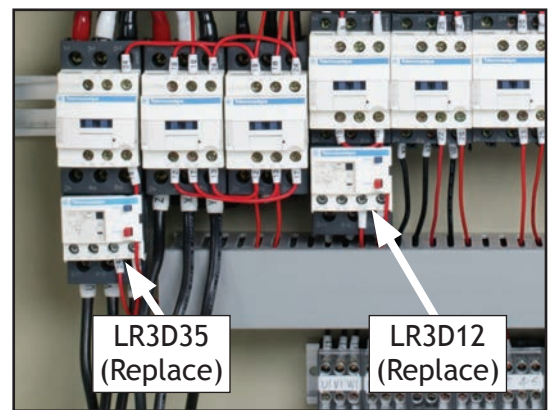

New Upper Roller Air Cylinder

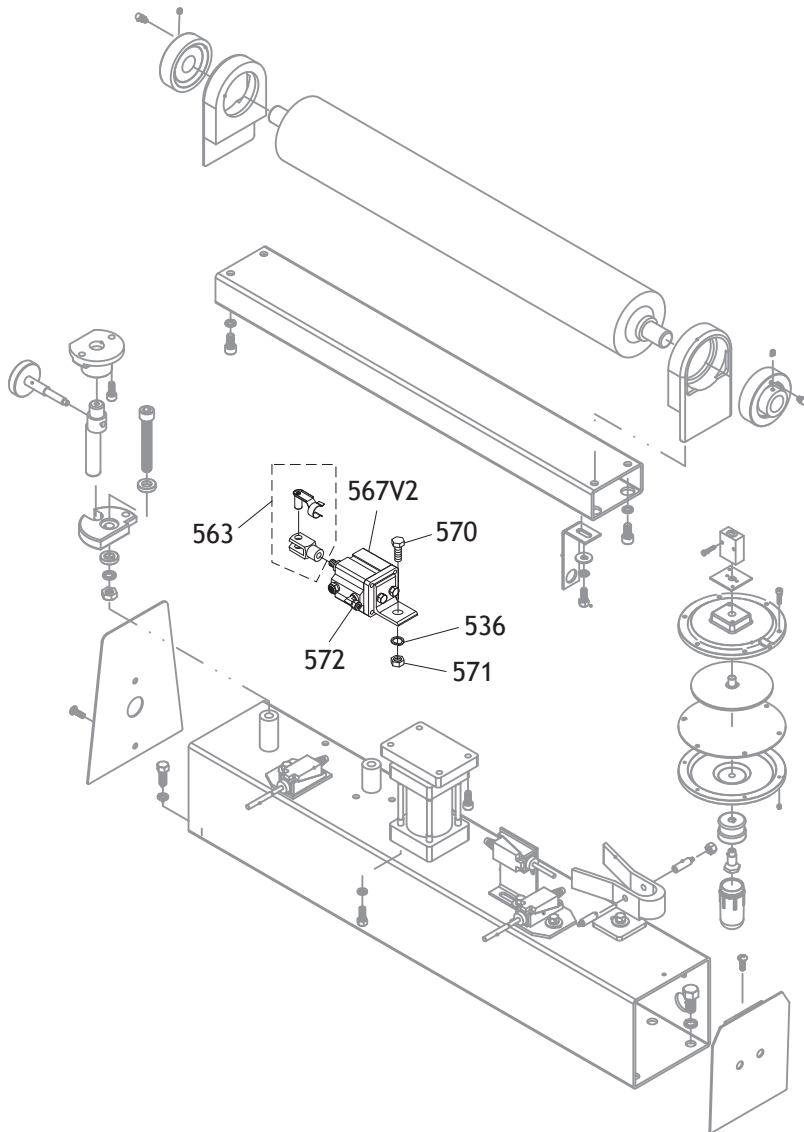

Previous Version Oscillation Diaphragm Assembly (P/N 567)

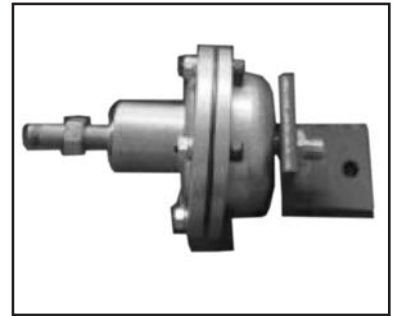

New Version Air Cylinder (P/N 567V2)



REF	PART #	DESCRIPTION
536	X1756536	LOCK WASHER 5/16
563	X1756563	CLEVIS ASSEMBLY
567V2	X1756567V2	OSCILLATION AIR CYLINDER 50 X 4 V2.01.14

REF	PART #	DESCRIPTION
570	X1756570	HEX BOLT 5/16-18 X 1-1/2
571	X1756571	HEX NUT 5/16-18
572	X1756572	CONNECTOR 1/4N X 1/4T X 90-DEG

Belt Oscillation (W1756)

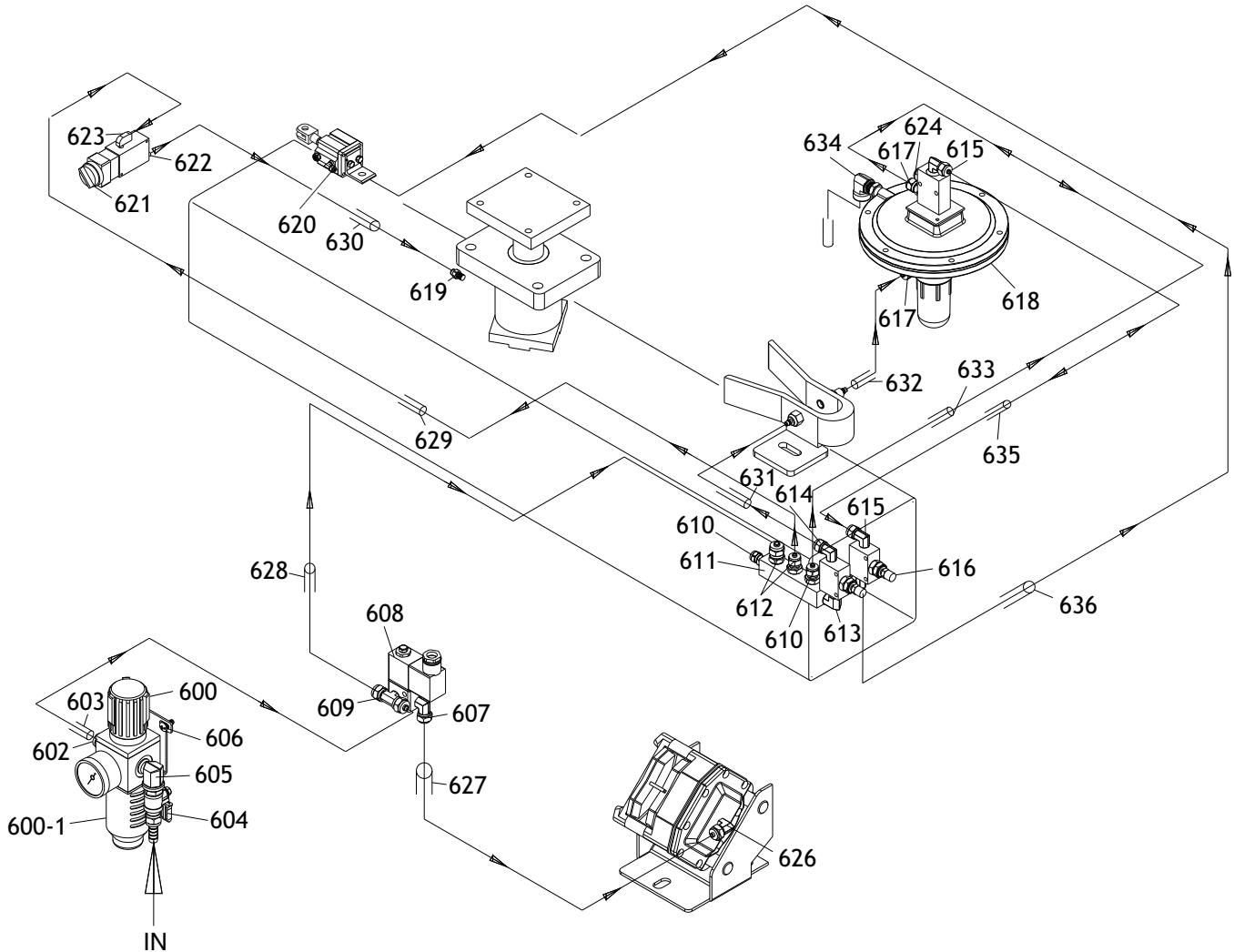

Belt Oscillation (W1757)

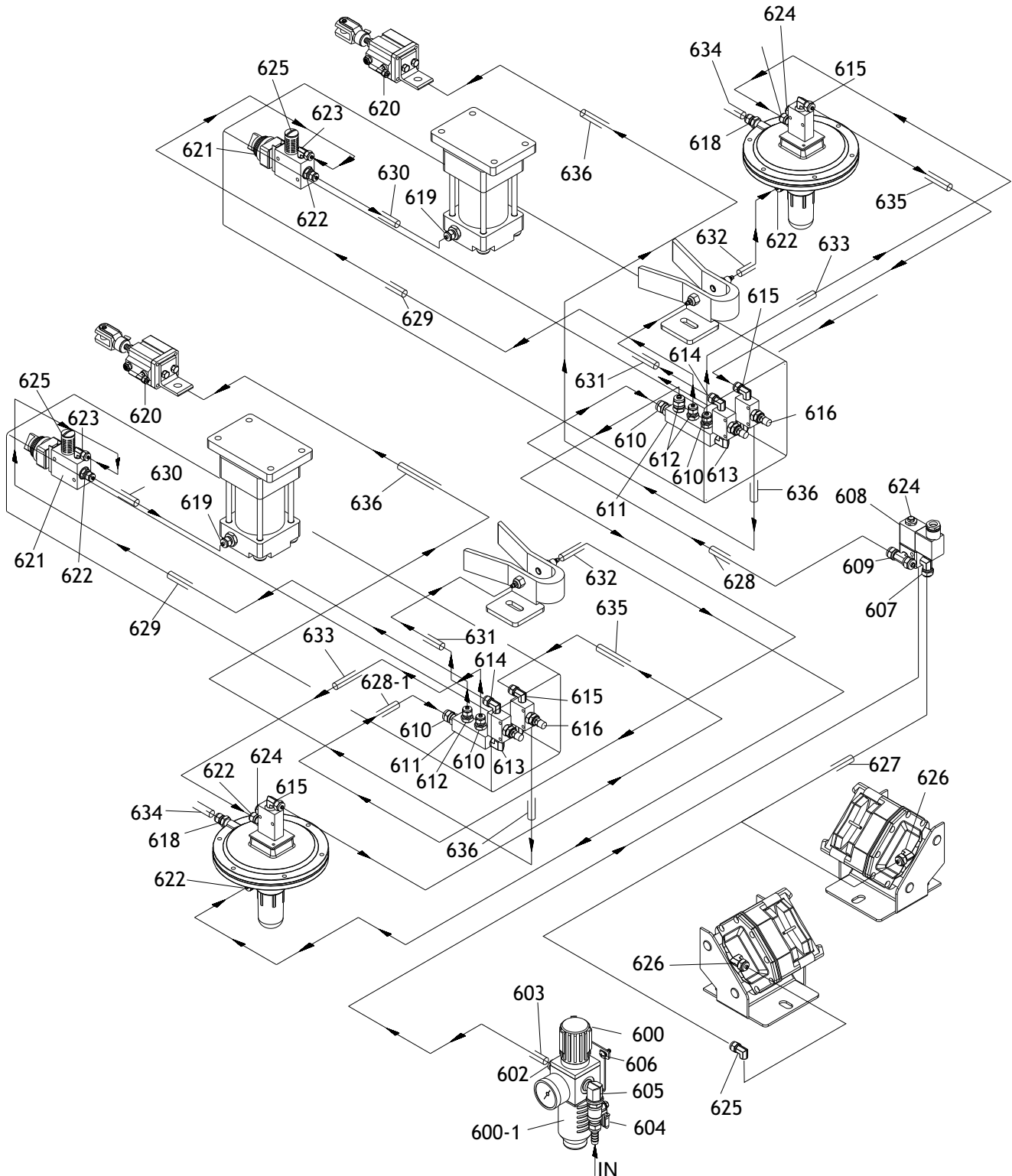



Belt Oscillation Parts List

REF	PART #	DESCRIPTION
600	X1756600	PRESSURE REGULATOR
600-1	X1756600-1	FILTER CUP
602	X1756602	BRONZE CONNECTOR 5/16N X 1/4T
603	X1756603	FLEXIBLE HOSE 8X900MM
604	X1756604	AIR SWITCH 1/4"
605	X1756605	ELBOW 1/4T X 1/4T 90° (W1756)
605	X1757605	ELBOW 1/4T X 1/4T 90° (W1757)
606	X1756606	PHLP HD SCR 10-24 X 5/8
607	X1756607	ELBOW 5/16N X 1/8T 90°
608	X1756608	SOLENOID VALVE
609	X1756609	T-FITTING 5/16N X 5/16N X 1/8T
610	X1756610	CONNECTOR 1/4N X 1/4T
611	X1756611	MANIFOLD 1/4N
612	X1756612	CONNECTOR 5/16N X 1/4T
613	X1756613	ELBOW 1/4T X 1/8T X 90° (W1756)
613	X1757613	ELBOW 1/4T X 1/8T X 90° (W1757)
614	X1757614	CONNECTOR 1/4N X 1/8T 90°
615	X1757615	CONNECTOR 1/4N X 1/8T 90°
616	X1756616	THROTTLE VALVE 1/8"
617	X1756617	CONNECTOR 1/4N X 1/8T (W1756)
618	X1756618	CONNECTOR 1/4N 90°
619	X1756619	CONNECTOR 1/4N X 3/8T
620	X1756620	CONNECTOR 1/4N X 1/4T x 90°

REF	PART #	DESCRIPTION
621	X1756621	AIR SWITCH 1/8"
622	X1756622	CONNECTOR 1/4N X 1/8T
623	X1756623	CONNECTOR 1/4N X 1/8T 90°
624	X1756624	BUFFER 1/8"
625	X1757625	BUFFER (PLASTIC) 1/8" (W1757)
626	X1756626	CONNECTOR 5/16N X 1/8T 90°
627	X1756627	FLEXIBLE HOSE 8 X 700MM (W1756)
627	X1757627	FLEXIBLE HOSE 8 X 900MM (W1757)
628	X1756628	FLEXIBLE HOSE 8 X 1400MM
629	X1756629	FLEX HOSE 6 X 1600/1800MM (W1756)
629	X1757629	FLEX HOSE 6 X 1100/1420MM (W1757)
630	X1756630	FLEXIBLE HOSE 6 X 750/950MM (W1756)
630	X1757630	FLEX HOSE 6 X 500/620MM (W1757)
631	X1756631	FLEXIBLE HOSE 6 X 600MM (W1756)
631	X1757631	FLEXIBLE HOSE 6 X 560MM (W1757)
632	X1756632	FLEXIBLE HOSE 6 X 250MM (W1756)
632	X1757632	FLEXIBLE HOSE 6 X 650MM (W1757)
633	X1756633	FLEXIBLE HOSE 6 X 650MM
634	X1756634	FLEXIBLE HOSE 6 X 300MM
635	X1756635	FLEXIBLE HOSE 6 X 650MM
636	X1756636	FLEX HOSE 6 X 1500/1700MM (W1756)
636	X1757636	FLEX HOSE 6 X 860/1350MM (W1757)



MODEL W1756/W1757 43" WIDE-BELT SANDER



OWNER'S MANUAL

Phone: (360) 734-3482 • Online Technical Support: tech-support@shopfox.biz

COPYRIGHT © AUGUST, 2007 BY WOODSTOCK INTERNATIONAL, INC.

WARNING: NO PORTION OF THIS MANUAL MAY BE REPRODUCED IN ANY SHAPE OR FORM WITHOUT
THE WRITTEN APPROVAL OF WOODSTOCK INTERNATIONAL, INC.



WARNING!

This manual provides critical safety instructions on the proper setup, operation, maintenance and service of this machine/equipment.

Failure to read, understand and follow the instructions given in this manual may result in serious personal injury, including amputation, electrocution or death.

The owner of this machine/equipment is solely responsible for its safe use. This responsibility includes but is not limited to proper installation in a safe environment, personnel training and usage authorization, proper inspection and maintenance, manual availability and comprehension, application of safety devices, blade/cutter integrity, and the usage of personal protective equipment.

The manufacturer will not be held liable for injury or property damage from negligence, improper training, machine modifications or misuse.



WARNING!

Some dust created by power sanding, sawing, grinding, drilling, and other construction activities contains chemicals known to the State of California to cause cancer, birth defects or other reproductive harm. Some examples of these chemicals are:

- Lead from lead-based paints.
- Crystalline silica from bricks, cement and other masonry products.
- Arsenic and chromium from chemically-treated lumber.

Your risk from these exposures varies, depending on how often you do this type of work. To reduce your exposure to these chemicals: Work in a well ventilated area, and work with approved safety equipment, such as those dust masks that are specially designed to filter out microscopic particles.

Contents

INTRODUCTION	2	SERVICE	32
Woodstock Technical Support.....	2	General	32
W1756 Machine Specifications	3	Table Calibration.....	32
W1757 Machine Specifications	6	Platen Service	33
Controls and Features	9	Table Limit Switches	34
SAFETY	11	Brake Service	35
Standard Safety Instructions	11	Oscillation Timing.....	36
Additional Safety for Wide-Belt Sanders	13	Oscillation Speed.....	37
ELECTRICAL	14	Table Parallelism.....	38
220V/440V 3-Phase Operation	14	Pressure Rollers	39
Phase Converter	14	V-Belt Tension	41
Electrical Specifications	14	Changing V-Belts	42
Converting to 440V	15	Feed Belt Replacement	43
SETUP	16	Feed Belt Tension.....	45
Unpacking	16	Sanding Belt Replacement.....	45
Inventory	16	Feed Belt Tracking.....	46
Machine Placement	17	Sanding Belt Tracking Limit Switches	46
Cleaning Machine.....	17	Sanding Belt Tension Safety Switch	47
Air Hose.....	18	Air System Diagram	48
Dust Collection	18	General Control Panel Wiring	49
Sanding Belt.....	19	Wiring Box Electrical Diagram 220V.....	50
Pressure Roller Height.....	20	Wiring Box Components 220V	51
Breather Pin.....	20	General Electric Diagram (W1756) 220V ...	52
Test Run	21	General Electric Diagram (W1757) 220V ...	53
Recommended Adjustments	22	Motor and Transformer Connection	54
OPERATIONS	23	Troubleshooting	55
Control Panel	23	PARTS	57
General	24	Electrical & Controls	57
Setting Feed Speed	24	Tools & Cabinet	59
Choosing Sandpaper	25	Sanding Motor & Frame (W1756)	61
Amp Draw Meter	25	Sanding Motor & Frame (W1757)	62
Emergency Stop Plate	26	Table Lift	64
Keypad and Display	26	Feed & Conveyor	66
Sanding Workpiece.....	27	Upper Roller	68
Platen Adjustment	28	Belt Oscillation (W1756)	70
MAINTENANCE	29	Belt Oscillation (W1757)	71
General	29	Sanding Drum & Pressure Roller (W1756) ...	73
Lubrication	29	Sanding Drum & Pressure Roller (W1757) ...	74
Cleaning Sanding Belts	30	Label Placement	76
Cleaning Feed Belt.....	30		
Air System	31		
Dust and Water Traps	31		





INTRODUCTION

Woodstock Technical Support

This machine has been specially designed to provide many years of trouble-free service. Close attention to detail, ruggedly built parts and a rigid quality control program assure safe and reliable operation.

Woodstock International, Inc. is committed to customer satisfaction. Our intent with this manual is to include the basic information for safety, setup, operation, maintenance, and service of this product.

We stand behind our machines! In the event that questions arise about your machine, please contact Woodstock International Technical Support at (360) 734-3482 or send e-mail to: tech-support@shopfox.biz. Our knowledgeable staff will help you troubleshoot problems and process warranty claims.

If you need the latest edition of this manual, you can download it from <http://www.shopfox.biz>.
If you have comments about this manual, please contact us at:

Woodstock International, Inc.
Attn: Technical Documentation Manager
P.O. Box 2309
Bellingham, WA 98227
Email: manuals@woodstockint.com



MACHINE SPECIFICATIONS



Phone #: (360) 734-3482 • Online Tech Support: tech-support@shopfox.biz • Web: www.shopfox.biz

MODEL W1756 WIDE-BELT SANDER

Motors

Sanding Drum

Type	TEFC Induction
Horsepower	25 HP
Voltage.....	220/440V
Prewired	220V
Phase	Three-Phase
Amps	64/32A
Speed.....	1725 RPM
Cycle	60 Hz
Number Of Speeds	1
Power Transfer	Triple V-Belt Drive
Bearings.....	Sealed and Lubricated

Conveyor Feed

Type	TEFC Induction
Horsepower	2 HP
Voltage.....	220/440V
Prewired	220V
Phase	Three-Phase
Amps	6/3A
Speed.....	1725 RPM
Cycle	60 Hz
Number Of Speeds	Adjustable
Power Transfer	V-Belt Drive
Bearings.....	Sealed and Lubricated

Table Elevation Feed

Type	TEFC Induction
Horsepower	1/4 HP
Voltage.....	220/440V
Prewired	220V
Phase	Three-Phase
Amps	1.2/0.6A
Speed.....	1725 RPM
Cycle	60 Hz
Number Of Speeds	1
Power Transfer	V-Belt Drive
Bearings.....	Sealed and Lubricated



Product Dimensions

Weight 2303 lbs.
 Length/Width/Height 50 x 62 x 70 in.
 Foot Print (Length/Width) 60 x 20-1/2 in.

Shipping Dimensions

Type Wood Slat Crate
 Content..... Machine
 Weight 2490 lbs.
 Length/Width/Height 53 x 65 x 72 in.

Electrical

Switch ON/OFF Emergency Stop
 Switch Voltage 200V
 Recommended Circuit Size..... 90/60 amp

Main Specifications

Operation Information

No. of Sanding Drums..... 1
 Maximum Board Width 43 in.
 Minimum Board Width 2 in.
 Maximum Board Thickness 6 in.
 Minimum Board Thickness 3/16 in.
 Minimum Board Length 14 in.
 Sanding Drum Speed 2200 FPM
 Sanding Drum Diameter 4"
 Conveyor Feed Rate 14 - 60 FPM
 Sanding Belt Length 60 in.
 Sanding Belt Width..... 43 in.

Drum Specifications

Infeed Sanding Drum Type..... Spiral Grooved Rubber
 Infeed Sanding Drum Size..... 4 in.
 Infeed Sanding Drum Durometer (Shore Type A) 65
 Outfeed Sanding Drum Type Steel
 Outfeed Sanding Drum Size..... 3-1/2 in.

Platen Specifications

Platen Type Felt
 Platen Length 44-1/2 in.
 Platen Width 3-1/2 in.

Construction

Conveyor Belt Construction Rubber
 Body Construction..... Steel
 Base Construction Steel
 Paint..... Epoxy



Other Related Information

Floor To Belt Height	34 in.
Belt Tracking.....	Pneumatic
Sanding Belt Tension	Pneumatic
No Of Pressure Rollers.....	2
Pressure Roller Type.....	Rubber
Pressure Roller Size.....	2 in.
Conveyor Belt Length.....	78-3/4 in.
Conveyor Belt Width.....	43 in.
Belt Roller Size	4 in.
No Of Dust Ports.....	5
Dust Port Size.....	4 in.
Air Requirement.....	75 PSI

Other

ISO Factory	ISO 9001
Country Of Origin	Taiwan
Warranty.....	1 Year
Customer Assembly Time	20 Minutes

Features

- Variable Feed Speeds
- Independent Motor Control
- Disc Brake Emergency Stop
- Pneumatic Belt Tracking
- Digital Amp/Load Meter
- Digital Keypad Controlled Table Elevation



MACHINE SPECIFICATIONS



Phone #: (360) 734-3482 • Online Tech Support: tech-support@shopfox.biz • Web: www.shopfox.biz

MODEL W1757 WIDE-BELT SANDER

Motors

Sanding Drum

Type	TEFC Induction
Horsepower	25 HP
Voltage	220/440V
Prewired	220V
Phase	Three Phase
Amps	64/32A
Speed.....	1725 RPM
Cycle	60 Hz
Number Of Speeds	1
Power Transfer	Triple V-Belt Drive
Bearings.....	Sealed and Lubricated

Conveyor Feed

Type	TEFC Induction
Horsepower	2 HP
Voltage.....	220/440V
Prewired	220V
Phase	Three
Amps	6/3A
Speed.....	1725 RPM
Cycle	60 Hz
Number Of Speeds	Adjustable
Power Transfer	V-Belt Drive
Bearings.....	Sealed and Lubricated

Table Elevation Feed

Type	TEFC Induction
Horsepower	1/4 HP
Voltage.....	220/440V
Prewired	220V
Phase	Three
Amps	1.2/0.6A
Speed.....	1725 RPM
Cycle	60 Hz
Number Of Speeds	1
Power Transfer	V-Belt Drive
Bearings.....	Sealed and Lubricated

W1756/W1757 43" Wide-Belt Sander

Product Dimensions

Weight	3186 lbs.
Length/Width/Height	60-1/2 x 63-1/2 x 66-1/2 in.
Foot Print (Length/Width)	61 x 31-1/2 in.

Shipping Dimensions

Type	Wood Slat Crate
Content.....	Machine
Weight	3384 lbs.
Length/Width/Height	68 x 64 x 78-5/8 in.

Electrical

Switch	ON/OFF Emergency Stop
Switch Voltage	200V
Recommended Circuit Size.....	90/60 amp

Main Specifications

Operation Information

No. of Sanding Drums.....	2
Maximum Board Width	43 in.
Minimum Board Width.....	2 in.
Maximum Board Thickness.....	6 in.
Minimum Board Thickness	1/4 in.
Minimum Board Length.....	14 in.
Front Drum Speed.....	3543 FPM
Rear Drum Speed.....	2565 FPM
Front Drum Diameter	7-7/8"
Rear Drum Diameter	4"
Conveyor Feed Rate	14 - 60 FPM
Sanding Belt Length	60 in.
Sanding Belt Width.....	43 in.

Drum Specifications

Infeed Sanding Drum Type.....	Spiral Grooved Rubber
Infeed Sanding Drum Size.....	4 in.
Outfeed Sanding Drum Type	Steel
Outfeed Sanding Drum Size.....	3-1/2 in.
Front Sanding Drum Durometer (Shore Type A).....	65
Rear Sanding Drum Durometer (Shore Type A).....	65-70

Platen Specifications

Platen Type	Felt
Platen Length.....	44-1/2 in.
Platen Width	3-1/2 in.

Construction

Conveyor Belt Construction	Rubber
Body Construction.....	Steel
Base Construction	Steel
Paint.....	Epoxy

Other Related Information

Floor To Belt Height	34 in.
Belt Tracking.....	Pneumatic
Sanding Belt Tension	Pneumatic
No Of Pressure Rollers.....	3
Pressure Roller Type.....	Rubber



Pressure Roller Size.....	2 in.
Conveyor Belt Length.....	102-23/64 in.
Conveyor Belt Width.....	43 in.
Belt Roller Size	4 in.
No Of Dust Ports.....	10
Dust Port Size.....	4 in.
Air Requirement.....	75 PSI

Other

ISO Factory.....	ISO 9001
Country Of Origin	Taiwan
Warranty.....	1 Year
Customer Assembly Time	20 Minutes

Features

- Variable Feed Speeds
- Independent Motor Control
- Disc Brake Emergency Stop
- Pneumatic Belt Tracking
- Digital Amp/Load Meter
- Digital Keypad Controlled Table Elevation

Controls and Features

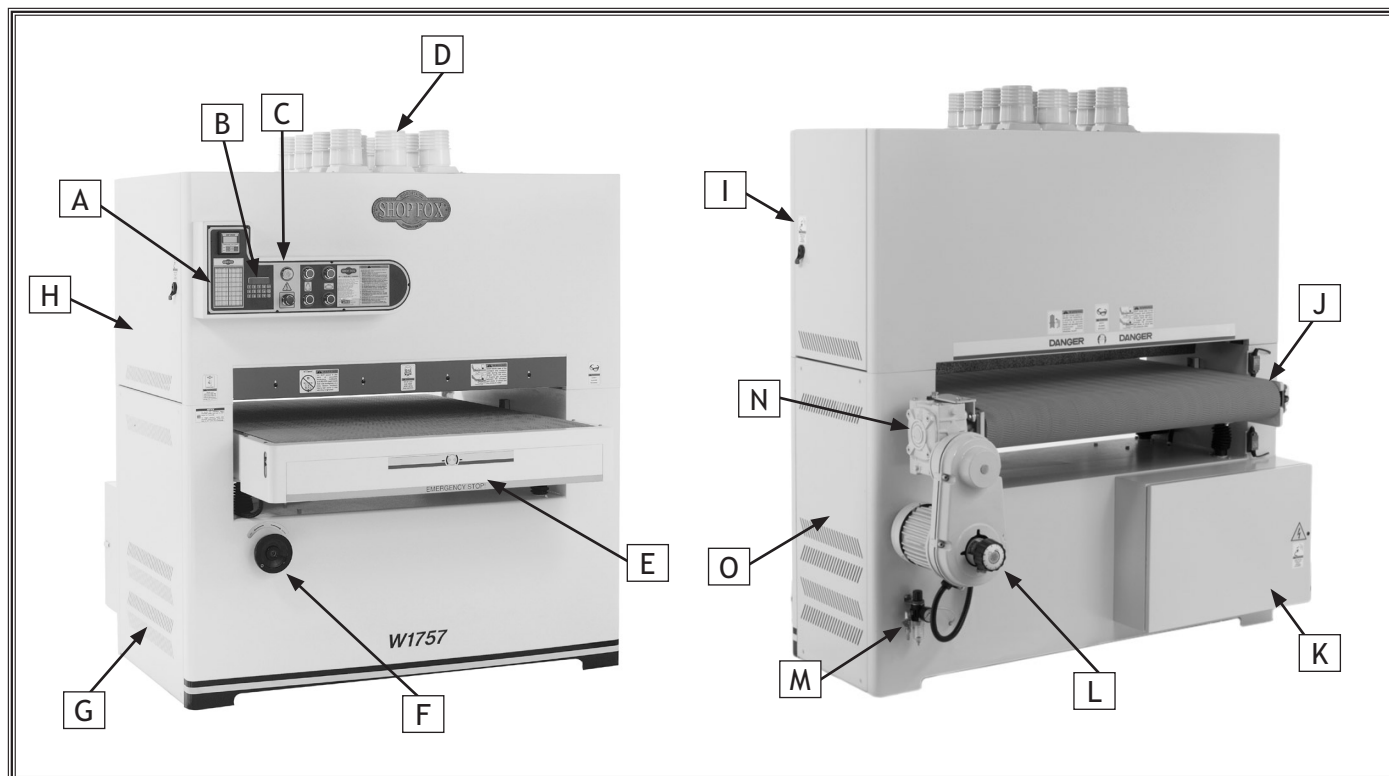

Figure 1. Front and rear views.

- | | |
|---|--|
| <ul style="list-style-type: none"> A. Amperage Load Chart B. Digital Table Height Key Pad C. Control Panel D. 4" Dust Collection Ports E. Emergency Stop Plate F. Table Height Handwheel G. Table Lift Motor Access Panel H. Upper Left Access Door | <ul style="list-style-type: none"> I. Upper Right Access Door J. Non-Slip Feed Belt K. Main Wiring Box L. Feed Belt Speed Control M. Air Pressure Regulator N. Feed Belt Gear Box O. Sanding Motor Access Panel |
|---|--|

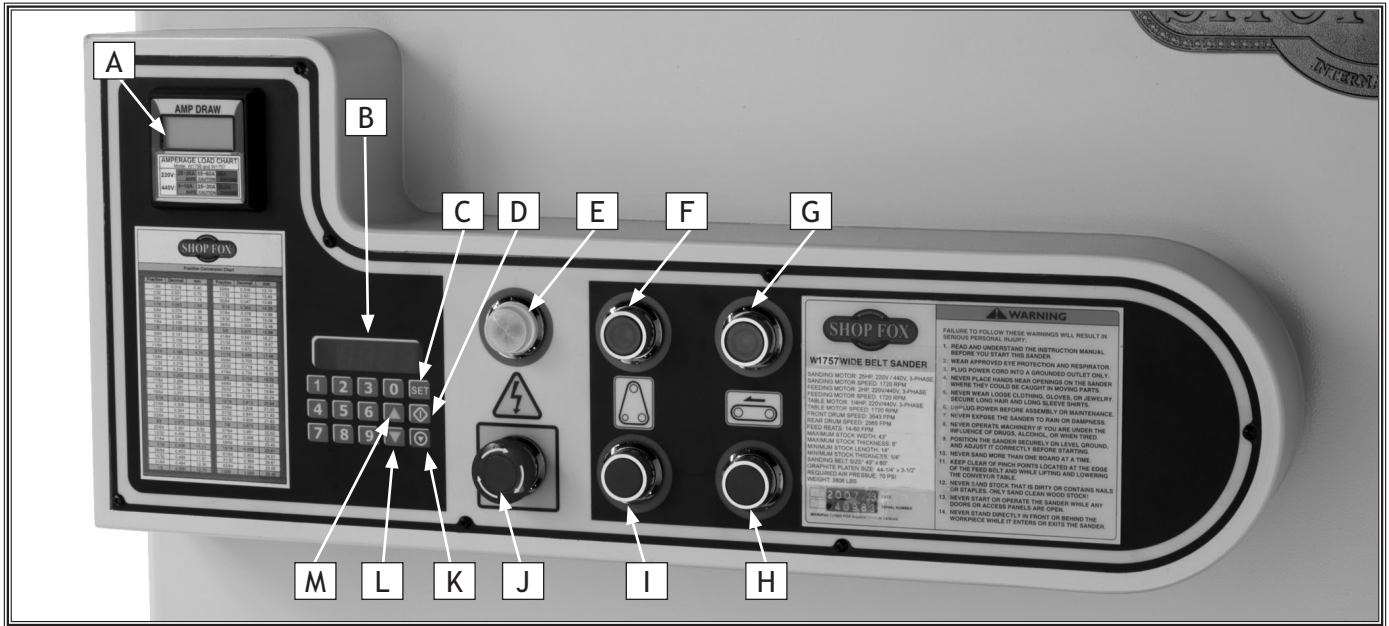

Figure 2. Control panel.

- | | |
|---------------------------------|-----------------------------|
| A. Digital Amp Draw Meter | H. Feed Belt Stop Button |
| B. Table-Height Digital Readout | I. Sanding Belt Stop Button |
| C. Table Set (Enter) Key | J. Emergency Stop Button |
| D. Table Start Key | K. Table Stop Key |
| E. Power Light | L. Table Down Key |
| F. Sanding Belt Start Button | M. Table Up Key |
| G. Feed Belt Start Button | |

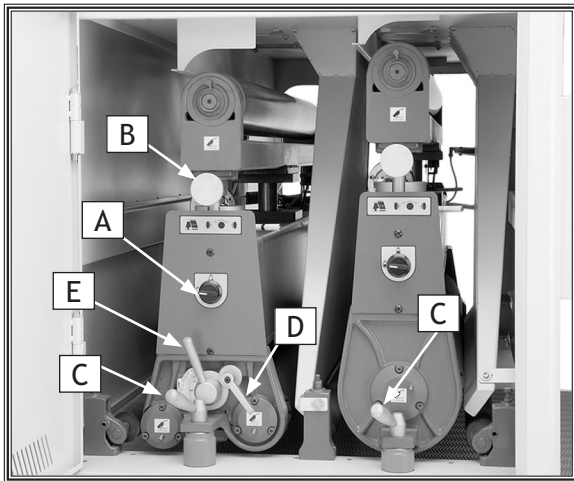

Figure 3. Inside left access door (Model W1757 shown).

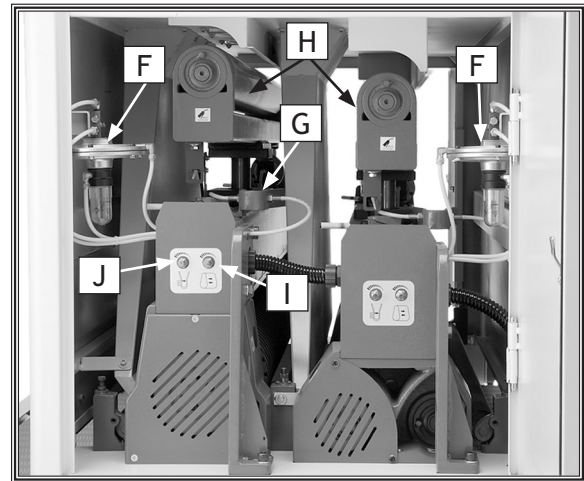

Figure 4. Inside right access door (Model W1757 shown).

- | | |
|---------------------------------|----------------------------------|
| A. Belt Tension Knob | F. Diaphragm Valve Assembly |
| B. Tracking Adjustment Knob | G. Air Fork and Air Jet |
| C. Lock Post Release Lever | H. Upper Rollers |
| D. Platen Adjustment Lock Lever | I. Speed Control Adjustment Knob |
| E. Platen Adjustment Lever | J. Airflow Adjustment Knob |

SAFETY

**READ MANUAL BEFORE OPERATING MACHINE.
FAILURE TO FOLLOW INSTRUCTIONS BELOW WILL
RESULT IN PERSONAL INJURY.**

DANGER

Indicates an imminently hazardous situation which, if not avoided, WILL result in death or serious injury.

WARNING

Indicates a potentially hazardous situation which, if not avoided, COULD result in death or serious injury.

CAUTION

Indicates a potentially hazardous situation which, if not avoided, MAY result in minor or moderate injury.

NOTICE

This symbol is used to alert the user to useful information about proper operation of the equipment, and/or a situation that may cause damage to the machinery.

Standard Safety Instructions

1. **READ THROUGH THE ENTIRE MANUAL BEFORE STARTING MACHINERY.** Machinery presents serious injury hazards to untrained users.
2. **ALWAYS USE ANSI APPROVED SAFETY GLASSES WHEN OPERATING MACHINERY.** Everyday eye-glasses only have impact resistant lenses—they are NOT safety glasses.
3. **ALWAYS WEAR AN NIOSH APPROVED RESPIRATOR WHEN OPERATING MACHINERY THAT PRODUCES DUST.** Wood dust is a carcinogen and can cause cancer and severe respiratory illnesses.
4. **ALWAYS USE HEARING PROTECTION WHEN OPERATING MACHINERY.** Machinery noise can cause permanent hearing damage.
5. **WEAR PROPER APPAREL.** DO NOT wear loose clothing, gloves, neckties, rings, or jewelry which may get caught in moving parts. Wear protective hair covering to contain long hair and wear non-slip footwear.
6. **NEVER OPERATE MACHINERY WHEN TIRED, OR UNDER THE INFLUENCE OF DRUGS OR ALCOHOL.** Be mentally alert at all times when running machinery.
7. **ONLY ALLOW TRAINED AND PROPERLY SUPERVISED PERSONNEL TO OPERATE MACHINERY.** Make sure operation instructions are safe and clearly understood.
8. **KEEP CHILDREN AND VISITORS AWAY.** Keep all children and visitors a safe distance from the work area.
9. **MAKE WORKSHOP CHILD PROOF.** Use padlocks, master switches, and remove start switch keys.

10. **NEVER LEAVE WHEN MACHINE IS RUNNING.** Turn power off and allow all moving parts to come to a complete stop before leaving machine unattended.
11. **DO NOT USE IN DANGEROUS ENVIRONMENTS.** DO NOT use machinery in damp, wet locations, or where any flammable or noxious fumes may exist.
12. **KEEP WORK AREA CLEAN AND WELL LIT.** Clutter and dark shadows may cause accidents.
13. **USE A GROUNDED EXTENSION CORD RATED FOR THE MACHINE AMPERAGE.** Undersized cords over-heat and lose power. Replace extension cords if they become damaged. DO NOT use extension cords for 220V machinery.
14. **ALWAYS DISCONNECT FROM POWER SOURCE BEFORE SERVICING MACHINERY.** Make sure switch is in OFF position before reconnecting.
15. **MAINTAIN MACHINERY WITH CARE.** Keep blades sharp and clean for best and safest performance. Follow instructions for lubricating and changing accessories.
16. **MAKE SURE GUARDS ARE IN PLACE AND WORK CORRECTLY BEFORE USING MACHINERY.**
17. **REMOVE ADJUSTING KEYS AND WRENCHES.** Make a habit of checking for keys and adjusting wrenches before turning machinery *ON*.
18. **CHECK FOR DAMAGED PARTS BEFORE USING MACHINERY.** Check for binding and alignment of parts, broken parts, part mounting, loose bolts, and any other conditions that may affect machine operation. Repair or replace damaged parts.
19. **USE RECOMMENDED ACCESSORIES.** Refer to the instruction manual for recommended accessories. The use of improper accessories may cause risk of injury.
20. **DO NOT FORCE MACHINERY.** Work at the speed for which the machine or accessory was designed.
21. **SECURE WORKPIECE.** Use clamps or a vise to hold the workpiece when practical. A secured workpiece protects your hands and frees both hands to operate the machine.
22. **DO NOT OVERREACH.** Keep proper footing and balance at all times.
23. **MANY MACHINES WILL EJECT THE WORKPIECE TOWARD THE OPERATOR.** Know and avoid conditions that cause the workpiece to "kickback."
24. **ALWAYS LOCK MOBILE BASES (IF USED) BEFORE OPERATING MACHINERY.**
25. **BE AWARE THAT CERTAIN DUST MAY BE HAZARDOUS** to the respiratory systems of people and animals, especially fine dust. Make sure you know the hazards associated with the type of dust you will be exposed to and always wear a respirator approved for that type of dust.

Additional Safety for Wide-Belt Sanders

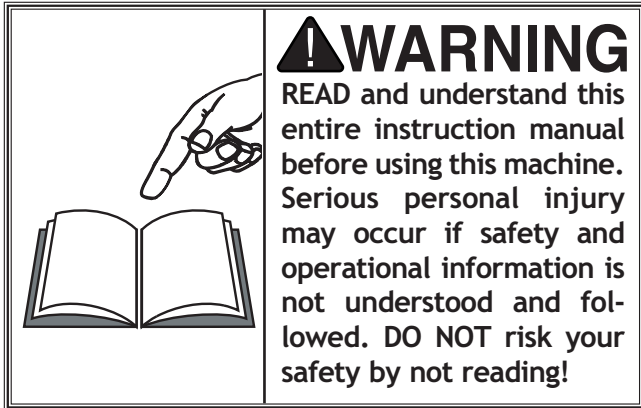

SAFETY

1. **INFEED/OUTFEED AREA.** When feeding workpiece into the machine, keep clear of kickback path by standing to the side of the feed belt. Kickback is when the workpiece is thrown off the sander by the force of the sanding drums.
2. **WORKPIECE FEEDING.** Never force workpiece into sander, and feed only one workpiece at a time.
3. **CLOTHING.** Roll up or button sleeves, tie all loose clothing or hair so it will keep clear of entanglement hazards.
4. **WORKPIECE LIMITS.** Never sand workpieces narrower than 2", thinner than $\frac{3}{16}$ " (Model W1756) or $\frac{1}{4}$ " (Model W1757), or shorter than 14".
5. **HANDS.** Never place hands near, or in contact with, sanding drums or feed belt during operation.
6. **MAINTENANCE.** Perform machine inspections/maintenance service at the appropriate intervals.
7. **POWER AND AIR DISCONNECT.** Unless specifically stated in the manual, always disconnect the power source and air from the machine when performing maintenance, adjustments, or assembly.
8. **UNATTENDED MACHINE.** Never leave the machine running unattended.
9. **SANDPAPER.** Replace sanding belt when it becomes worn or damaged.
10. **FOREIGN MATERIAL.** Always inspect workpiece for nails, staples, knots, and other imperfections that could be dislodged and thrown from the machine during sanding operations.
11. **DUST COLLECTION.** Never operate the sander without an adequate dust collection system in place and running.
12. **INTENDED USE.** Sand wood and wood products only, not plastics or metals.
13. **ALLERGIES.** Certain woods may cause an allergic reaction in people and animals, especially when exposed to fine dust. Make sure you know what type of wood dust you will be exposed to and always wear an approved respirator.
14. **ACCESS DOORS.** Never perform sanding operations when the side access doors are open.
15. **UNDERSTAND INSTRUCTIONS.** Never allow unsupervised or untrained personnel to operate the machine. Make sure instructions regarding machine operation are approved, correct, safe, and clearly understood.

ELECTRICAL

!WARNING

The machine must be properly set up before it is safe to operate. **DO NOT** connect this machine to the power source until instructed to do so in the "Test Run" portion of this manual.

220V/440V 3-Phase Operation

The Model W1756/W1757 is prewired for 220V 3-phase operation, but may be rewired for 440V 3-phase operation (see Pages 15 & 54).

This machine must be hardwired to a locking shutoff switch by a qualified electrician. Hardwiring involves a permanent installation with conduit runs that can only be accomplished safely by a qualified electrician. As always, observe all applicable electrical codes when connecting this machine to power.

This machine must be grounded! Verify the ground before connecting this machine to the power source.

Phase Converter

The power from the manufactured power leg (wild wire) of a phase converter fluctuates, which may damage electrical components if connected to the wrong incoming power terminal. If you must use a phase converter for 3-phase power, only connect the L2 "wild wire" to the S terminal (See Page 50).

The wire from the S terminal can handle some fluctuation because it goes directly to the motor. The power going to the R and T terminals goes to the transformer and must be consistent to prevent damage.

Electrical Specifications

Model	Voltage	Amp Draw	Min. Circuit Size	Connection	Cord	Extension Cord
W1756/W1757	220V	71.2	90A	Hardwire	Conduit Setup	N/A (Hardwire Only)
W1756/W1757	440V	35.6	60A	Hardwire	Conduit Setup	N/A (Hardwire Only)

!WARNING



TURN OFF and LOCK your master power switch so no power is available to the sander before connecting electrical wires! If you ignore this warning serious electrical shock may occur causing injury or death!

!WARNING



Attempting to connect this machine to the power source without a qualified electrician greatly increases the risk of electrocution, fire, or machine damage.

!WARNING



This machine must be grounded! If you have any questions about correct electrical installation, contact a qualified electrician for assistance to make sure all connections are safe and adhere to your local electrical codes.

Converting to 440V

To convert this machine for 440V three-phase operation, you must purchase two thermal overload relays, Part X1756037-1 and X1756037-2, or purchase the 440V Conversion Kit, Part X1756037 (refer to **Pages 57 & 58**).

If you do not have three-phase power available for your wide-belt sander, you must install a phase converter (Refer to Phase Converter sub-section, **Page 14** for requirements and setup).

To convert the sander for 440V, do these steps:

1. DISCONNECT THE SANDER FROM THE POWER SOURCE!
2. Open the electrical box located on the back of the machine.
3. On the transformer, remove the wire connected to the 220V terminal for your model of sander, and connect it to the 440V terminal, as shown in **Figure 5** and in the illustrations on **Page 54**.
4. Refer to **Figure 6** and open the main wiring box on your machine.
5. Swap out the applicable thermal relays at the locations shown in **Figure 6** or in the photo on **Page 54**, and set them to 16A and 3A.
 - For the Model W1756 and W1757, use 440V Conversion Kit #X1756037 or purchase Part X1756037-1 and X1756037-2, and change out the two relays.
6. Wire the sanding belt, feed belt, and table elevation motors as shown on the diagrams on the inside of each motor wire cover, or refer to the diagrams shown on **Page 54, Motor and Transformer Connections**.

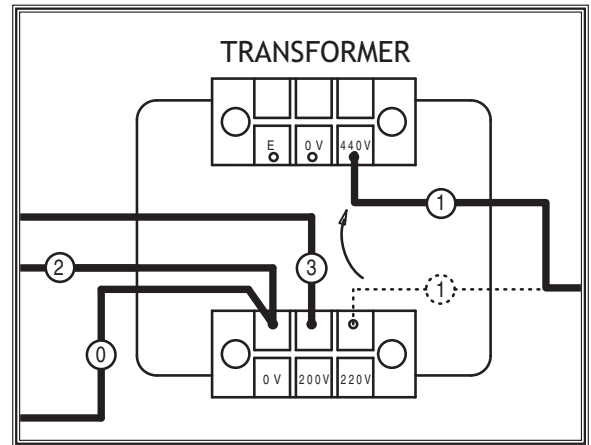

Figure 5. Rewiring transformer from 220V to 440V.

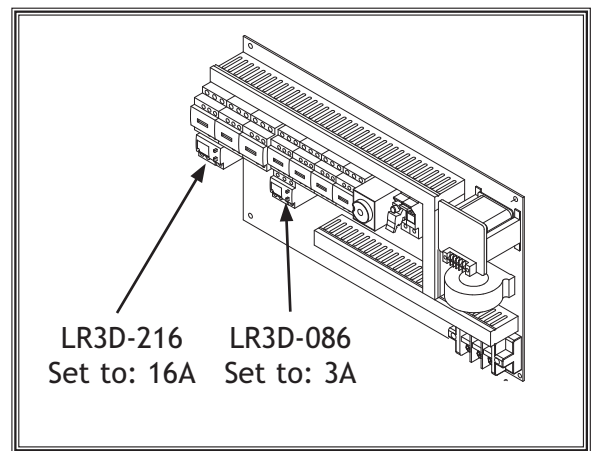

Figure 6. Thermal overload relays.

SETUP

Unpacking

This machine has been carefully packaged for safe transportation. If you notice the machine has been damaged during shipping, please contact your authorized Shop Fox dealer immediately.

Inventory

The following is a description of the main components shipped with the Model W1756/W1757. Lay the components out to inventory them.

Note: *If you can't find an item on this list, check the mounting location on the machine or examine the packaging materials carefully. Occasionally we pre-install certain components for safer shipping.*

Box Inventory (Figure 7)	Qty
A. Sanding Belt 100 Grit	1
B. Sanding Belt 180 Grit	1
C. Dust Ports 4" (Model W1756)	5
Dust Ports 4" (Model W1757)	10
D. Platen Felt.....	1
E. Platen Graphite Flaps.....	2
F. Tool Box.....	1
– Phillips Head Screwdriver #2	1
– Standard Screwdriver #2	1
– Open-End Wrench 8/10mm	1
– Open-End Wrench 12/14mm	1
– Open-End Wrench 17/19mm	1
– Metric Hex Wrench Set 10 Pcs.....	1
– Door Keys	2
– Ceramic Limit Switch Rub Rods	2
– Flexible Grease Gun Extension	1
– Platen Removal Tool	1

⚠ WARNING

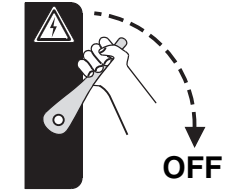

Keep machine disconnected from power until instructed otherwise.



⚠ WARNING

SUFFOCATION HAZARD!

Immediately discard all plastic bags and packing materials to eliminate choking/suffocation hazards for children and animals.

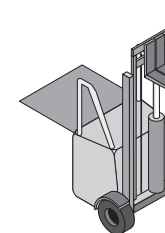

⚠ WARNING

The Model W1756/W1757 is a heavy machine weighing over 2400 lbs. Use power or hydraulic equipment to avoid serious personal injury or death.

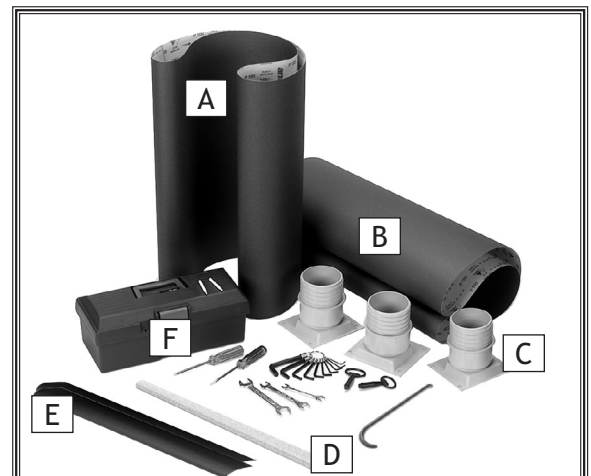

Figure 7. Parts and tool inventory.

SETUP

Machine Placement

- **Floor Load:** This machine distributes a heavy load in a small footprint. Some shop floors may require additional bracing to support both machine and operator.
- **Working Clearances:** Consider existing and anticipated needs, size of material to be processed through the machine, and space for auxiliary stands, work tables or other machinery when establishing a location for your wide-belt sander.
- **Lighting:** Lighting should be bright enough to eliminate shadow and prevent eye strain.
- **Electrical:** Electrical circuits must be dedicated or large enough to handle amperage requirements. Outlets must be located near each machine, so power or extension cords are clear of high-traffic areas. Follow local electrical codes for proper installation of new lighting, outlets, or circuits.
- **Dust Collection:** Place this machine as close to your dust collector as possible to eliminate long runs of large ducting and improve dust collection from the machine.

Cleaning Machine

The upper sanding drum on this machine is coated with a waxy grease that protects it from corrosion during shipment. Clean this grease off with a solvent cleaner or citrus-based degreaser. DO NOT use chlorine-based solvents such as brake parts cleaner or acetone—if you happen to splash some onto a painted surface, you will ruin the finish.

	<p>! WARNING NEVER clean with gasoline or other petroleum-based solvents. Most have low flash points, which make them extremely flammable. A risk of explosion and burning exists if these products are used. Serious personal injury may occur if this warning is ignored!</p>
--	---

	<p>! CAUTION ALWAYS work in well-ventilated areas far from possible ignition sources when using solvents to clean machinery. Many solvents are toxic when inhaled or ingested. Use care when disposing of waste rags and towels to be sure they DO NOT create fire or environmental hazards.</p>

	<p>! WARNING USE helpers or power lifting equipment to lift this wide-belt sander. Otherwise, serious personal injury may occur.</p>
--	--

	<p>! CAUTION MAKE your shop "child safe." Ensure that your workplace is inaccessible to kids by closing and locking all entrances when you are away. NEVER allow untrained visitors in your shop when assembling, adjusting or operating equipment.</p>
--	---

SETUP

Air Hose

To install the air line, do these steps:

1. Connect the air inlet (**Figure 8**) on the regulator to a compressed air line.
2. Make sure the red ON/OFF handle on the regulator is in the open position.
3. Lift the regulator knob (**Figures 8 & 9**) and rotate it until the gauge reads 75 PSI.

Note: Rotate the knob clockwise to increase the air pressure and counterclockwise to lower the air pressure.

4. Push the knob down until it snaps to lock it.

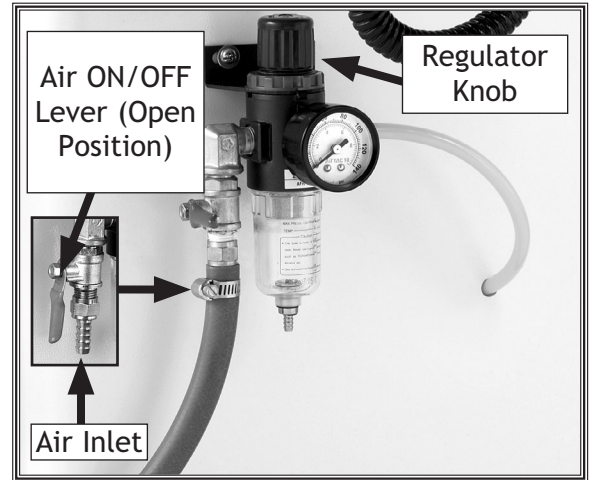

Figure 8. Air hose attached to regulator.

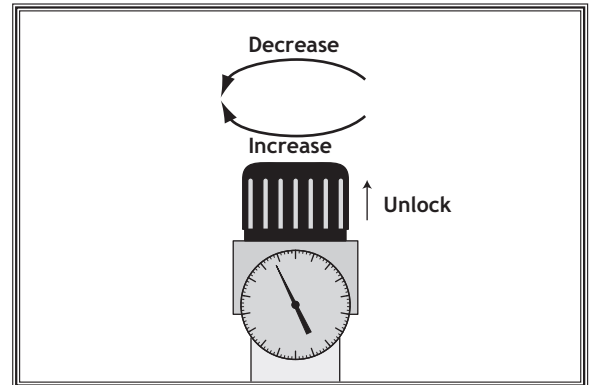

Figure 9. Regulator knob.

Dust Collection

An efficient and clean dust collection system is essential to the proper function of the sander. Ensuring a healthy work environment is also dependent upon cleaning and maintaining your dust collection system. We recommend connecting this wide-belt sander to a cyclone dust collector rather than a bag type dust collector, since a cyclone will handle fine dust particles better and experience fewer clogging problems.

Recommended CFM at Machine (W1756): 1500 CFM Min.
Recommended CFM at Machine (W1757): 2000 CFM Min.
 Do not confuse this CFM recommendation with the rating of the dust collector. To determine the CFM at the machine, you must take into account many variables, including the CFM rating of the dust collector, the length of hose between the dust collector and the machine, the amount of branches or Y's, and the amount of other open lines throughout the system. Explaining this calculation is beyond the scope of this manual. If you are unsure of your system, consult an expert or purchase a good dust collection "how-to" book.

To hook up a dust collection system, do these steps:

1. Install the dust ports (**Figure 10**) to the mounting locations on the top of the sanding unit with the supplied M6-1 x 10 Phillips head screws, or install a wide-belt sander dust hood.
2. Using 4" hose clamps, secure the hoses from your dust collection system to the dust ports (**Figure 10**).

⚠ CAUTION

DO NOT operate this machine without an adequate dust collection system. This machine creates substantial amounts of wood dust while operating. Failure to use a dust collection system can result in short and long-term respiratory illness.

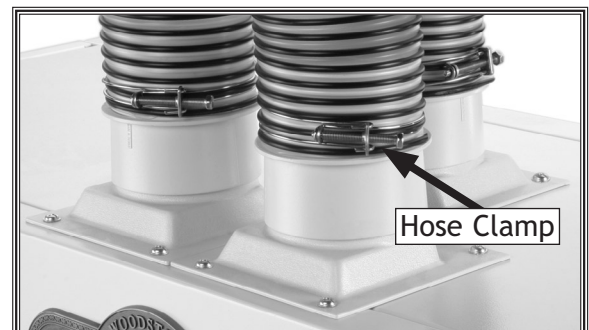

Figure 10. Dust collection hose attached to dust port.

SETUP

Sanding Belt

To install the sanding belt, do these steps:

1. REMOVE AIR PRESSURE COMPLETELY!
2. Remove the lock post release lever (Figure 11) by turning it counterclockwise $\frac{1}{2}$ turn and pulling it up and out of the mounting hole.
3. Remove the spacer block (Figure 11).
4. Making sure the rotation arrows on the sanding belt point the same direction as those shown in Figure 11, install the sanding belt by starting first on the upper roller and then the lower roller.

Note: The sanding belt must be centered between the limit switches, and the edge of the sanding belt must be between tongs of the belt oscillation controller fork, as shown in Figure 12. Damage to the sanding belt will occur if the sander is turned ON before the sanding belt is correctly positioned.

NOTICE

The directional arrow on the back of the sanding belt must be pointing in a counterclockwise direction during installation. Failure to install the sanding belt correctly could result in damage to the sanding belt or the sander itself.

5. Replace the spacer block and tighten down the lock post release lever.
6. Reconnect the sander to air pressure.
7. With your hands clear of all moving parts, check to make sure the belt tension knob is turned to the 12:00 position, to tension the belt.
 - If it is turned to the 9:00 position, the belt will have no tension.

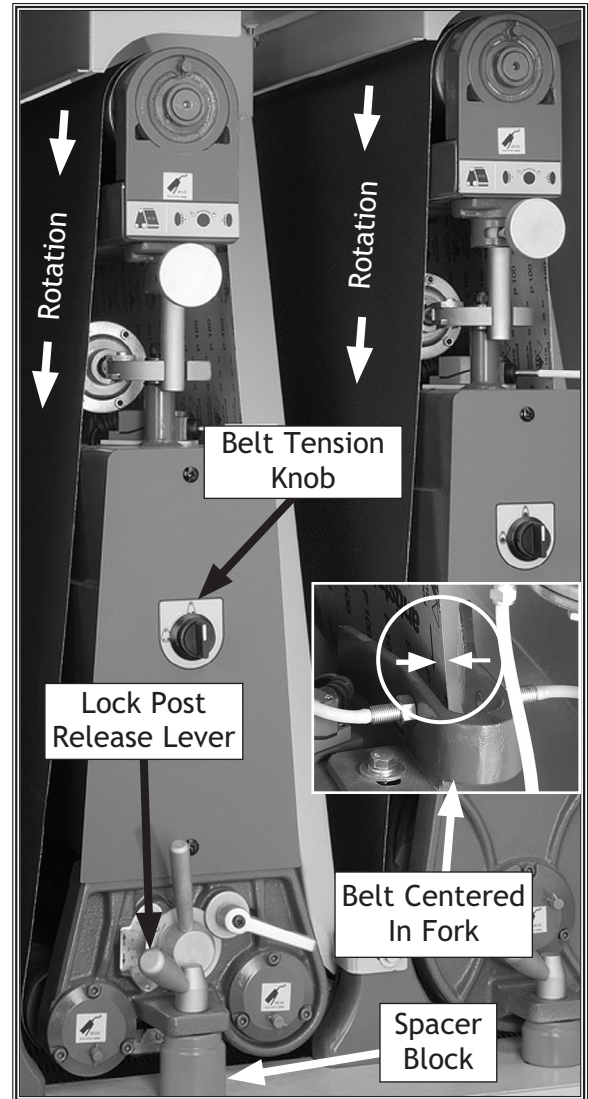

Figure 11. Components used when changing a sanding belt.

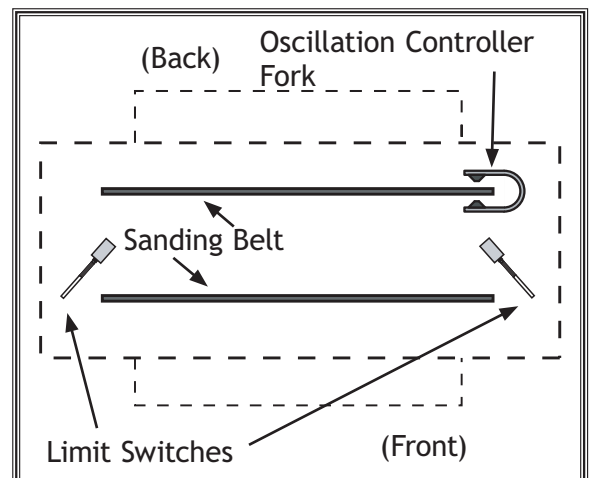

Figure 12. Sander Outline (Top View). Proper position of belt between the limit switches.

SETUP

Pressure Roller Height

The pressure rollers have been set at the factory, but to ensure safety, you should verify that they are set below the level of the sanding roller.

To check the pressure roller height, do these steps:

1. DISCONNECT THE SANDER FROM THE POWER SOURCE!
2. Place a piece of scrap wood of uniform thickness across the table so it spans both the front and the rear pressure rollers at the same time.
3. With the air pressure connected and the sanding belt installed and tensioned, manually raise the table and verify that the board touches both pressure rollers before it touches the sanding belt.

Note: *If the board does not touch both pressure rollers before it touches the sanding belt, then the pressure rollers must be adjusted before operation. See Pressure Rollers on Page 39 for step-by-step instructions.*

⚠ WARNING

It is absolutely essential to keep the pressure rollers set below the level of the sanding roller. If the pressure rollers are even with or higher than the sanding roller, the wood may be propelled from the sander at a high rate of speed. This situation could cause serious kick-back injury.

SETUP

Breather Pin

The Model W1756/W1757 has a breather sealing pin installed in the fill plug for the feed belt gear reducer.

Remove this pin before using your sander (see **Figure 13**); otherwise, the gear oil will expand with heat and the seals in the gear reducer may leak due to the pressure build up.

You may want to retain this pin if you plan on storing your sander for a long period of time.

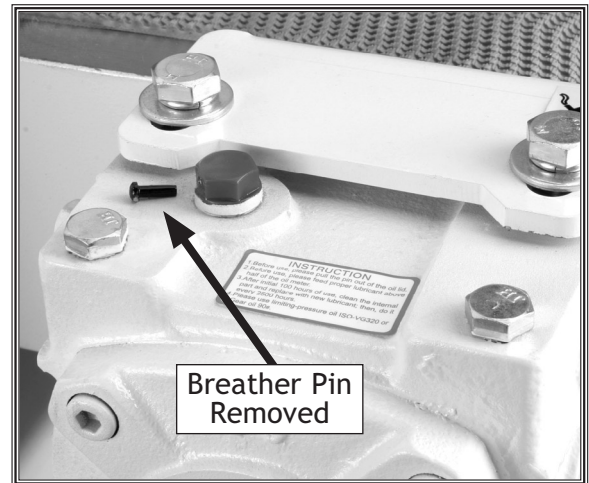

Figure 13. Breather sealing pin removed.

Test Run

Once the assembly is complete, test run your machine to make sure it runs properly and is ready for regular operation.

The test run consists of verifying the following: 1) The motor powers up and runs correctly, 2) the stop button safety feature works correctly, and 3) the feed belt motor turns the correct direction.

If, during the test run, you cannot easily locate the source of an unusual noise or vibration, stop using the machine immediately, then review **Troubleshooting** on **Page 55**.

If you still cannot remedy a problem, contact our Tech Support at (360) 734-3482 for assistance.

To test run the machine, do these steps:

1. Make sure you understand the safety instructions at the beginning of the manual, and verify that the machine is setup properly.
2. Ensure all tools and objects used during setup are cleared away from the machine, and close all panels or access doors.
3. Make sure the machine is connected to an air compressor and the pressure gauge reads 75 PSI.
4. Make sure all wiring is correct.
5. Put on your safety glasses and respirator.
6. Connect the machine to the power source.
7. Push the EMERGENCY STOP button in, then twist it clockwise so it pops out. When the STOP button pops out, the switch is reset and ready for operation (see **Figure 14**).
8. Verify that the power is not connected out of phase by pressing the TABLE UP and TABLE DOWN keys, using the criteria below:
 - If the table moves in the same direction as the button description, it is moving in the correct direction.
 - If the table moves in the opposite direction to the arrow on the button, it is moving in the wrong direction.

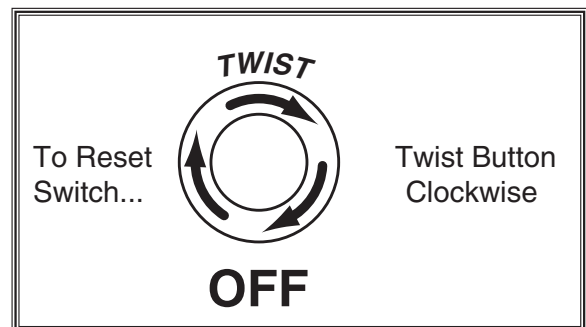
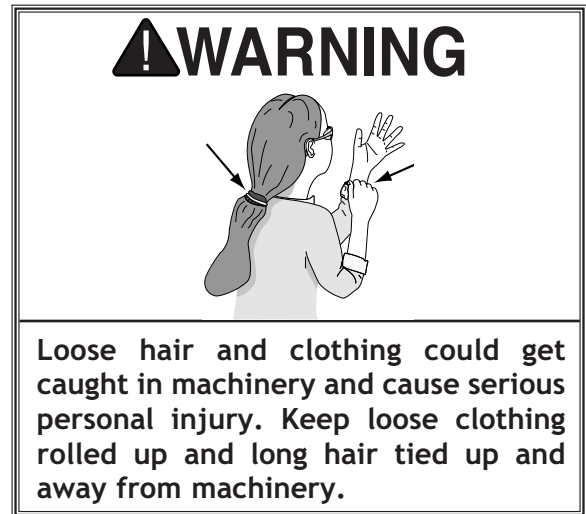

Figure 14. Resetting the switch.

Stop the machine, shut **OFF** the power source, then swap any two wires (U2, V2, or W2) at the "Table Up/Down" motor connection as shown in **Figure 15**.

9. Press the FEED BELT START and FEED BELT STOP buttons. The feed belt should start, run, and stop smoothly.
10. Press the SANDING BELT START and SANDING BELT STOP buttons. The sanding belt should start, run, and stop smoothly.
 - When operating correctly, the machine runs smoothly with little or no vibration or rubbing noises.

However, you will hear an air leaking sound from the oscillation controller fork jet (**Figure 12**).

- Investigate and correct strange or unusual noises or vibrations before operating the machine further. Always stop the machine and disconnect it from power before investigating or correcting potential problems.

11. Press the EMERGENCY STOP button to stop the machine.
12. WITHOUT resetting the switch, press the FEED BELT START button. The machine should not start.
 - If the machine does not start, the EMERGENCY STOP button safety feature is working correctly.
 - If the machine does start (with the EMERGENCY STOP button pushed in), immediately disconnect power to the machine.

The STOP button safety feature is not working correctly. This safety feature must work properly before proceeding with regular operations. Call Tech Support for help.

13. Reset the EMERGENCY STOP button.
14. Press the FEED BELT START button, then press the emergency stop plate. The sander will come to a complete stop. The stop plate should only be used during emergencies. Sanding belts will wear quicker if this feature is used for daily shut down.
 - If the feed belt does not come to a complete stop, the emergency stop plate is not working correctly. Call Tech Support for help.

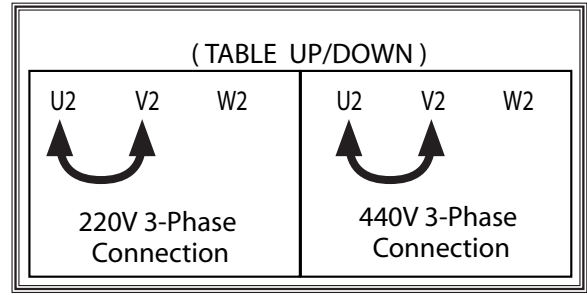

Figure 15. Example of switching Table Up/Down Motor connection wires.

NOTICE

Using the emergency stop system for daily machine shutdown will wear out the sanding belts and the brake pads. When shutting down the machine under non-emergency conditions, use the red OFF push buttons.

Recommended Adjustments

For your convenience, the adjustments listed below have been performed at the factory and require no further adjustment. However, we recommend that you verify that the adjustments are correct and to your satisfaction.

Recommended adjustment checklist:

1. Pressure Rollers (**Page 20**).
2. Air System (Air Regulator to 75 PSI; **Page 31**).
3. Table Calibration (**Page 32**).
4. Oscillation Timing (**Page 36**).
5. Oscillation Speed (**Page 37**).
6. Table Parallelism (**Page 38**).
7. V-Belt Tension (**Page 41**).
8. Feed Belt Tension (**Page 45**).
9. Feed Belt Tracking (**Page 46**).

OPERATIONS

Control Panel

Below is a summary of your sander control panel and the components that it controls. Use the list with **Figure 16** to become familiar with your sander.

- **Sanding Load Amp Meter:** Indicates the current amp load on the sanding motor when a sanding operation is in progress.
 - **Input LED:** Indicates the sander is waiting for new numerical dimension values.
 - **Run LED:** Indicates the feed belt lift motor is operating.
 - **Digital Readout:** Shows final table sanding depth.
 - **Table Up and Down Keys:** Manually cycles the table lift motor to raise and lower the table. Press the UP or DOWN key once for motorized table positioning in 0.005" (0.125mm) increments.
- For manual table positioning, turn the handwheel located under the front of the infeed table.
- **SET Key:** Press and hold the SET key for 3 seconds to calibrate display at the current board thickness; or press and hold key for 10 seconds to toggle the display between metric and standard measurement.
 - **Power Lamp:** Indicates when machine has power to the control panel.
 - **Sanding Belt Start and Stop Buttons:** Turns the sanding motor **ON** and **OFF** if the sander has air pressure and the belt is tensioned.
 - **Feed Belt Start and Stop Buttons:** Cycles the feed belt motor **ON** and **OFF** for feeding wood into the sander.
 - **Emergency Stop Button:** Stops all electrical power to motors in event of emergency, and stops sanding drums with an air-disc brake.
 - **Table Start and Stop Keys:** Moves table to a preset sanding depth; stops table movement immediately.
 - **Key Pad:** Enters the position of sanding depth.

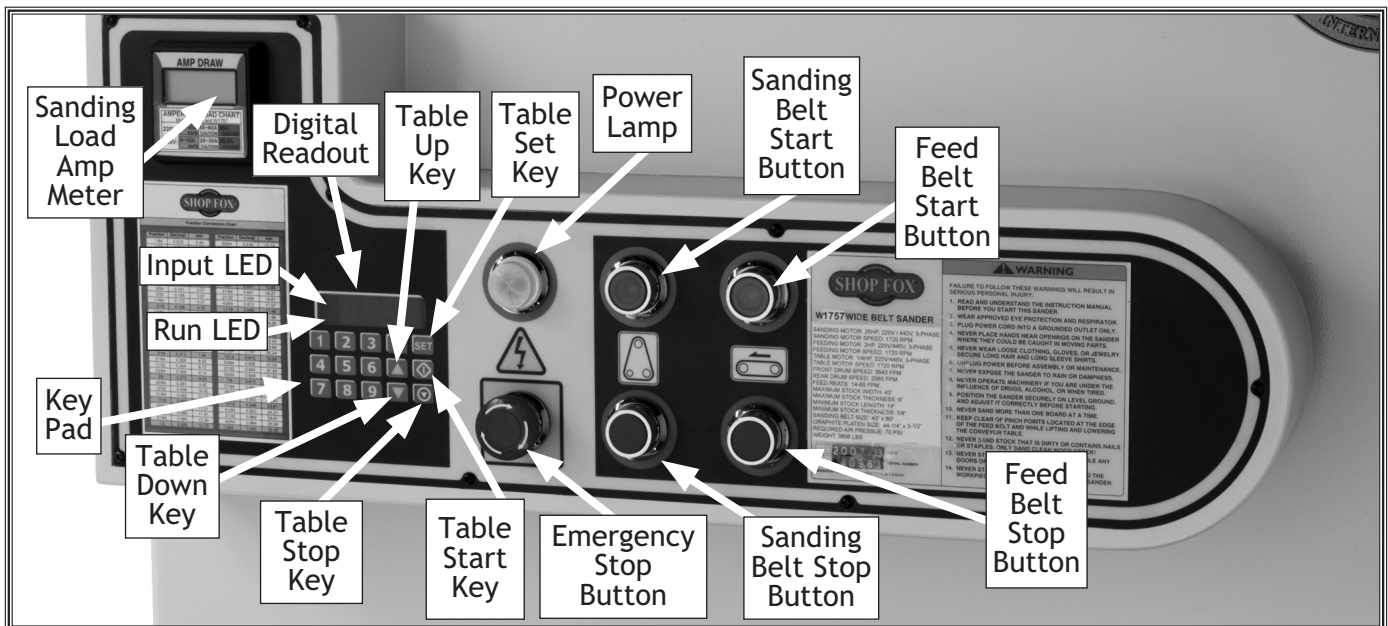

Figure 16. Control panel interface.

OPERATIONS

General

This sander will perform many types of operations that are beyond the scope of this manual. Many of these operations can be dangerous or deadly if performed incorrectly. This sander is only designed to sand wood—not metal, fiberglass, or plastics.

The instructions in this section are written with the understanding that the operator has the necessary knowledge and skills to operate this machine. **If at any time you are experiencing difficulties performing any operation, stop using the machine!**

If you are an inexperienced operator, we strongly recommend that you read books, trade articles, or seek training from an experienced *wide-belt sander* operator before performing any unfamiliar operations. **Above all, your safety should come first!**

Setting Feed Speed

The dial attached to the side of the feed belt motor cover (**Figure 17**) adjusts the feed rate of the sander.

To change the feed belt speed, do these steps:

1. Start the feed belt.
2. Turn the dial clockwise to decrease the feed rate and counterclockwise to increase it.

Note: *Never adjust the feed rate dial unless the feed belt is running, otherwise you can damage the control.*

Determining Ideal Feed Rates

Softwoods typically require a faster feed rate than hardwoods; however, there is no definitive rule to follow when determining the best feed rate. As a general rule, always start with the slowest feed rate and work your way up. We always recommend testing the feed rate using scrap wood similar to your workpiece. Be sure to monitor the amperage meter (see Page 25) when adjusting the feed rate. Decrease the feed rate if the load begins to slow the motor RPM.

! WARNING



DO NOT investigate problems or adjust the machine while it is running. Wait until the machine is turned OFF, unplugged and all working parts have come to a complete stop before proceeding!

! WARNING



Always wear safety glasses and a respirator when operating this machine. Failure to comply may result in serious personal injury, allergic reactions, or respiratory problems.



Figure 17. Variable feed rate dial.

Choosing Sandpaper

When selecting sandpaper, keep in mind that the Model W1756/W1757 accepts only 43" wide by 60" long belts.

The grit you choose will depend on the type of work, the species of wood and the stage of finishing. When choosing which sandpaper to use, use these grit numbers as a general guide to sandpaper type:

Grit	Type
60 or less	Coarse
80-100	Medium
120-150	Fine

We recommend using aluminum oxide sanding belts for the best results. The general rule of thumb is to sand a workpiece with progressively higher grit numbers, with no one grit increase of more than 50; however, the type of wood and desired finish will determine the best grit to use.

Note: When used on wide-belt sanders, sandpaper finer than 150 grit will often be problematic and load up or burn workpieces.

Amp Draw Meter

The amperage draw meter (Figure 18) is used to keep the machine from being overloaded during sanding operations.

As a general rule, always start with a small load and work your way up. DO NOT work your machine to its maximum load, or where you can hear the motor lose RPM; instead, make multiple passes or install a coarser grit sandpaper.

Amp load will be directly affected by many factors such as feed rate, depth of cut, wood type, sandpaper grit, and workpiece width. If the amp load is in the red load range, the machine is overloaded and motor damage may soon occur. Use the amp load chart on the meter to keep the amp load in the green range during operation.



Figure 18. Amp draw meter.

NOTICE

DO NOT VOID MACHINE WARRANTY! Keep the amp draw within the GREEN zone shown on the AMP LOAD CHART. If you operate the sander in the RED zone, motor damage may occur and will not be covered under warranty.

Emergency Stop Plate

When pushed, the emergency stop plate, shown in **Figure 19**, stops the electricity to the motors and also applies an air-disc brake to stop the sander immediately.

To use the emergency stop plate, push and hold it until the sander has come to a complete stop.

⚠ CAUTION

KEEP the sanding drum V-belts correctly tensioned (refer to Page 41). Otherwise, the sanding drum pulley will slip when the emergency brake is applied and not immediately stop the machine in the event of an emergency!

NOTICE

Using the emergency stop system for daily machine shutdown will wear out the sanding belts and the brake pads. Inspect for any grease or oil on the brake rotor, as oil reduces emergency braking ability.



Figure 19. Emergency stop plate.

Keypad and Display

You can push the **UP** or **DOWN** arrow keys to lift or lower the table, or you can use the automated function of auto height adjustment (**Page 27**) for your next sanding pass. All functions are controlled through the key pad and are presented on the digital display (see **Figure 20**).

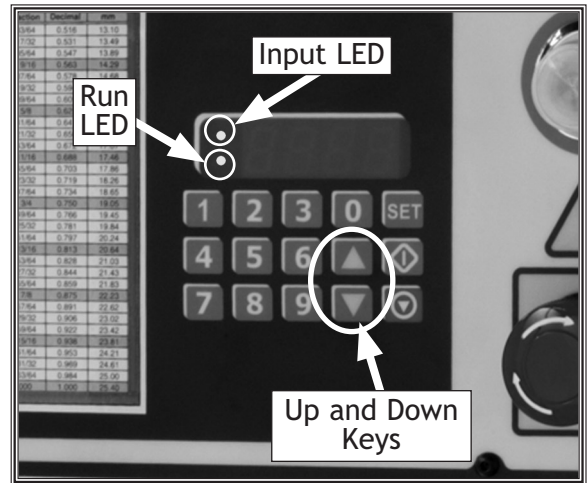

Figure 20. Digital display and keypad.

OPERATIONS

Sanding Workpiece

To achieve the best sanding results experiment with conveyor feed rate, sanding depth, various grits of sandpaper, and oscillation speed. Also, make sure the workpiece has been jointed and planed before sanding.

Typically, no more than 0.5mm (approx. $\frac{1}{64}$ ") of material is removed during each pass. Attempts to remove too much material can cause jamming, wood burning, rapid sandpaper wear or tearing, poor finish, short motor life, and belt slippage.

To sand a workpiece, do these steps:

1. Measure the workpiece and record the thickest spot.
2. Put on safety glasses, a dust mask, and hearing protection!
3. Make sure the sander is connected to power and compressed air and turn **ON** the dust collector and the sander.
4. Raise the table to the thickness of the workpiece and make an initial pass to eliminate any high spots.
5. Continue to raise the table 0.0625" between each successive pass until the sander begins to sand the entire workpiece.
6. Type in the thickness of your workpiece using the numeric key pad (Example: for a 2" thick workpiece type 2.000"), and press the table start key. **Note:** *The upper left corner Input LED will illuminate (See Figure 20), and the display numbers will flash when entering measurements.*
7. Measure the sanding depth needed. Example: let's say you need $\frac{1}{64}$ ".
8. Convert $\frac{1}{64}$ " fraction to a 0.016" decimal measurement using the conversion table on the sander.
9. Calculate the resulting workpiece thickness (2.000" – 0.016" = 1.984"), and type that thickness (1.984") on the key pad.
10. Press the table start key: The table will raise to the new setting. **Note:** *The computer rounds the sanding thickness measurements in increments of 0.005", and if you want to move the table up in 0.005" increments, just tap the up arrow. The same holds true for the down button.*

Tip

For best results when finish sanding, feed each piece through the sander two or three times without adjusting the depth of cut. Turn the workpiece 180° and feed it through two or three more times at this same depth. As always, use your best judgement. If you no longer hear the sanding belt making contact with the workpiece on successive cuts, then no further passes are needed at that depth.

Note: The lower left corner Run LED will illuminate and the display numbers will glow steadily when measurements have been accepted and the table is auto-adjusting. When the correct sanding depth is achieved, the lower left corner Run LED will turn off and the final resulting workpiece thickness is displayed.

11. Start the feed belt, stand to the side as shown in **Figure 21**, and feed the workpiece into the sander.
12. Observe the amp draw meter, and press the table down arrow key on the key pad to reduce the sanding depth if the amp load meter indicates motor overload, or reduce the feed rate.
13. Remove the workpiece from the outfeed side, which is now sanded down $\frac{1}{64}$ ". Re-sand the workpiece a couple of times more at this depth to ensure a consistent sanding depth.
14. Add a new sanding depth the same way as in **Steps 9** and **10**, and sand again.



Figure 21. Operator feeding workpiece at correct body position and out of the way of potential kickback.

Platen Adjustment

Your sander is equipped with an adjustable felt platen and graphite slip for those extra sensitive sanding operations. The platen position allows for three basic types of sanding. These different positions can be adjusted by rotating the height lever shown in **Figure 22**.

The three basic platen positions:

Platen Up: The platen is raised above the level of the sanding rollers. This position allows the front roller to remove large amounts of material quickly, but leaves a rough finish. The best belt grit for this position is #100 or coarser.

Platen Even: The platen is set even with the sanding rollers. The rollers work together with the platen to produce intermediate/final finishing. The best belt grit for this position is #100-#150.

Platen Down: The platen is lowered below the sanding rollers. The majority of the work is accomplished by the platen pressure on the workpiece. The result is a smooth, flat finish. The best belt grit for this position is #150. Avoid lowering the platen more than 0.2 mm below the sanding belt rollers, or you will prematurely wear the platen.

Note: The platen scale is in millimeter increments.

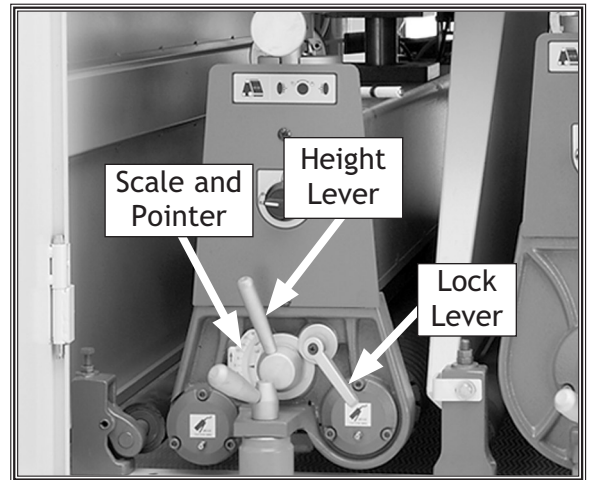

Figure 22. Platen controls.

MAINTENANCE

General

Regular periodic maintenance on your machine will ensure its optimum performance. Make a habit of inspecting your machine each time you use it.

Check for the following conditions and repair or replace when necessary:

- Loose mounting bolts.
- Damaged sanding belt.
- Worn or damaged wires.
- Water collection cups filled with water.
- Dust trap.
- Safety features.
- Any other condition that could hamper the safe operation of this machine.

Lubrication

Wipe off all sawdust and abrasives from grease fittings and plugs before lubrication. When lubricating machine parts, your goal is to achieve adequate lubrication to prevent rust, and a thin layer of lubricant to prevent metal-to-metal friction. Too much lubrication will attract dirt and sawdust, causing machine parts to bind.

Lubricate the following areas according to frequency of use:

Weekly. Give one or two pumps of a multi-purpose automotive grease to the grease fittings (Figure 23 & 24) located on the feed belt roller axles and the sanding belt roller axles. They are identified with yellow labels.

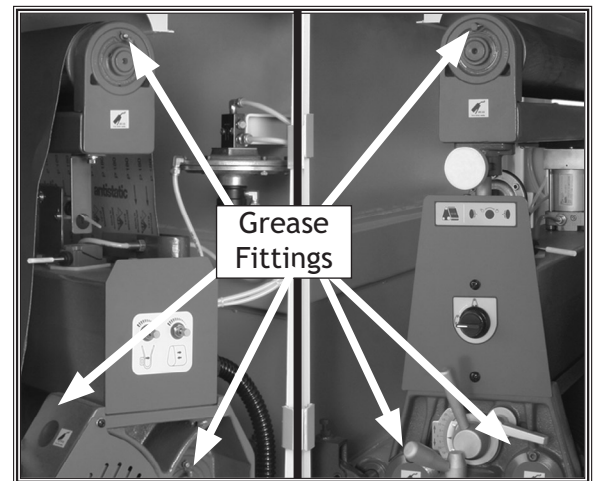
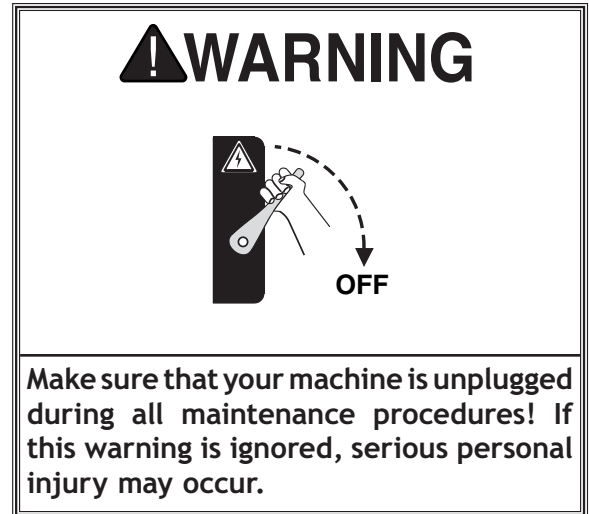

Figure 23. Right/left grease fitting locations.

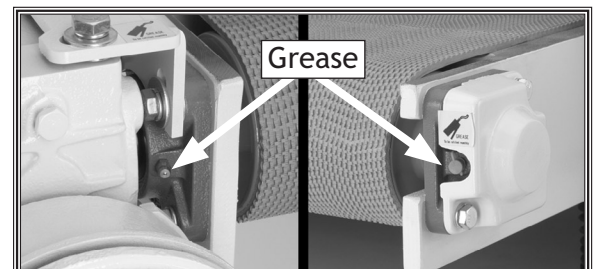

Figure 24. Conveyor grease fitting locations.

- **Monthly.** Pull the dust cover down and apply a generous amount of multi-purpose automotive grease to the table elevation screws (Figure 25). Be sure to re-position the dust covers when finished.

Remove the left lower side panel to access the table lifting mechanism. Apply multi-purpose automotive grease to the chain and gears associated with the table lifting mechanism (Figure 26). Be careful to not get grease on the V-belts. This could cause them to slip off of the pulleys. If you do, replace them.

- **Yearly.** Replace the internal white moisture filters on the air regulator.
- **After the First 100 Hours:** Replace the conveyor gear reducer oil (Figure 27) after the first 100 working hours of operation. We recommend 90 Wt. gear oil.
- **Every 2500 Hours:** After the first conveyor gear reducer oil change, replace the oil after every 2500 working hours of operation. We recommend 90 Wt. gear oil.

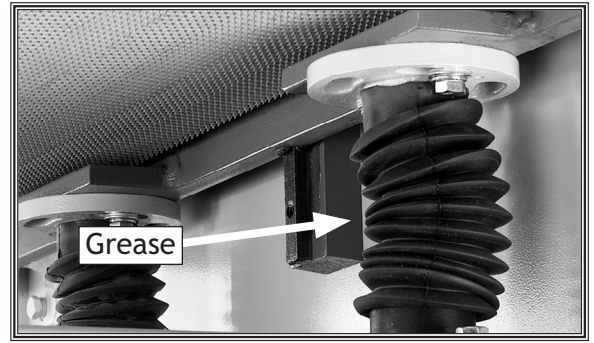

Figure 25. Table elevation screw (shown with dust cover).

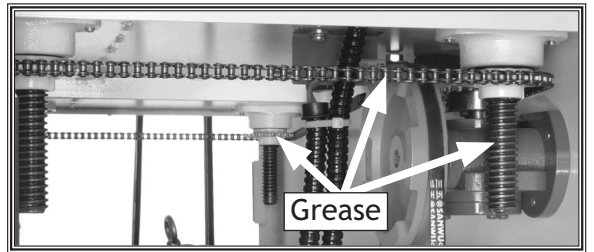

Figure 26. Table lifting mechanism lubrication location.

Cleaning Sanding Belts

To increase the working life of your sanding belts, clean them whenever they decrease in performance due to heavy loading. Use a Model D3003 Pro-Stik® Cleaning Pad as shown in Figure 28.

To clean the belts, simply set your table to the thickness of the cleaning pad, and run the pad through the sander two or three times. **DO NOT take too deep of a cut—the belt should barely touch the cleaning pad!**

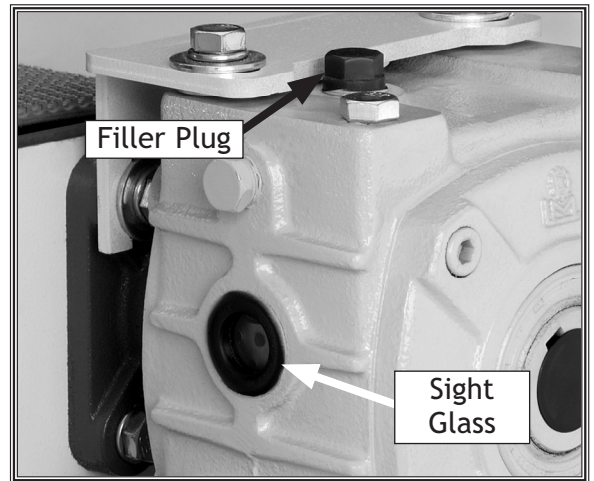

Figure 27. Gear reducer breather and filler plug.

Cleaning Feed Belt

Vacuum or sweep dust off the feed belt with compressed air. Use a diluted solution of mild dish cleaning soap and water with a clean rag to remove resin from the belt. Do NOT use solvent cleaners or harsh chemicals.



Figure 28. Pro-Stik® Cleaning Pad.

Air System

The air system is durable and reliable; however, components do wear with age. If you suspect that an item in your air system may be having problems, see the **Air System Diagram** on **Page 48** for troubleshooting locations.

Verify or set the following:

- Adjust regulator to 75 PSI.
- Carefully inspect all air lines for cracks, pinches, or hardening. Replace faulty hoses.
- Check the air connections for leaks. A small amount of soapy water in a questionable area will bubble if there is a leak.
- Make sure lines are not clogged. Remove a questionable line and blow through it as a test.

CAUTION

If a component in the air system is malfunctioning, bleed all air from the system, and fix the problem before you resume sanding.

Dust and Water Traps

Three collection traps on this wide-belt sander need to be emptied when they become half full. One water trap is attached to the bottom of the air regulator, and two dust traps are attached on the air diaphragm assemblies. **DO NOT** allow the water trap and dust bowls to become full.

Dust Traps: To empty the dust trap bowls, **TURN OFF AIR PRESSURE**, allow air pressure to bleed out, then unscrew and empty the bowls (**Figure 29**).

Water Trap: With the system under air pressure, push the lower drain valve and empty the water trap (**Figure 29**). Also, replace the internal white moisture filters yearly.

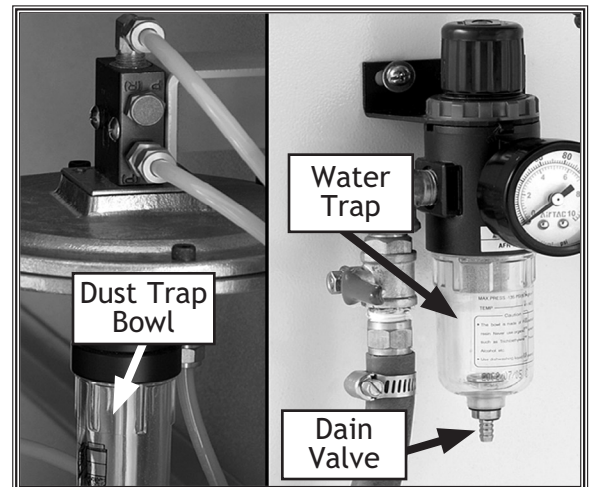

Figure 29. Diaphragm dust bowl and air regulator water trap.

SERVICE

General

This section covers the most common service adjustments or procedures that may need to be made during the life of your machine.

If you require additional machine service not included in this section, please contact Woodstock International Technical Support at (360) 734-3482 or send e-mail to: tech-support@shopfox.biz.

Table Calibration

Feed a test board through the sander and measure it in many locations on both sides along the length to test the accuracy of the digital thickness gauge.

To calibrate the digital thickness scale, do these steps:

1. Using a properly set-up planer, plane a board to uniform thickness.
2. Adjust the sander table far enough to place the planed board under the sander roller.
3. Using the handwheel, manually raise the table until the board just touches the sandpaper.
4. Remove the board without changing the table height. This ensures the table will be properly adjusted for the first sanding pass.
5. Run the board through the sander several times at the initial height setting. Manually raise the table 0.020" and pass the board through the sander several more times. Monitor the amperage meter and the resulting load on the sander.
6. Measure the thickness at various points around the board using a precise micrometer or set of calipers.
7. Continue sanding the board at that height until the average thickness measurement is within ± 0.003 ".

Note: *These final passes should be done without adjusting the table height. This ensures the most consistent average thickness.*

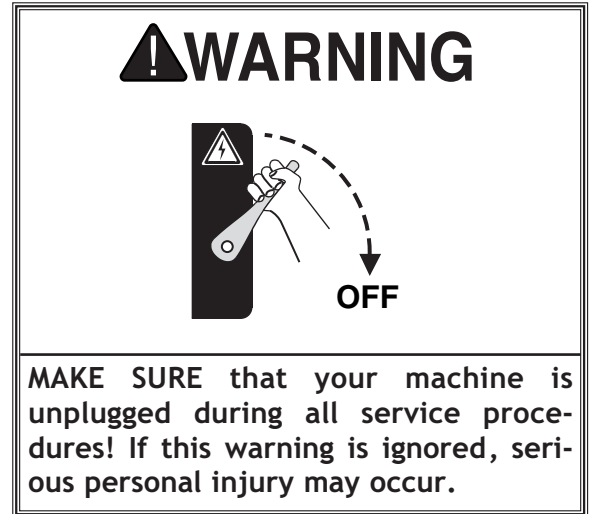

8. Observe the digital display read-out, it should indicate the average thickness of the sanded wood.
 - If it does, the sander is properly calibrated and accurate to the nearest 0.005".
 - If it does not, you must recalibrate the digital thickness scale.

To recalibrate the digital thickness scale, do these steps:

1. Without moving the table height, enter the numerical measurement of the average thickness of the sanded wood into the digital key pad on the control panel.

Note: The average thickness of the sanded wood should now be flashing on the digital read-out.

2. Press and hold the SET key until the display stops flashing. The sander is now correctly calibrated.

Platen Service

To replace the platen felt and graphite pad, do these steps:

1. DISCONNECT THE SANDER FROM THE POWER SOURCE AND REMOVE AIR PRESSURE COMPLETELY!
2. Open the left access door and remove the lock post release lever and spacer block.
3. Use the platen tool to remove the platen (see **Figure 30**).
4. Replace the platen felt pad and graphite pad.
5. Reinsert the platen until it stops.
6. Reinstall the lock post release lever and spacer block.
7. Close the access door.

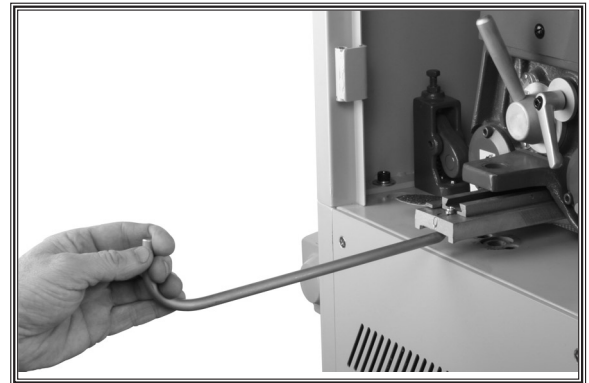

Figure 30. Removing platen.

Table Limit Switches

The table limit switches prevent the table lift motor from driving the table into the sanding drum. Periodically check and adjust (if required) the table stop switches to protect the feed belt.

To adjust table limit switches, do these steps:

1. Supply air to the sander and tension the sanding belt.
2. Push the down arrow key and lower the table until you achieve six inches between the sanding drum and the feed belt table surface.
3. Loosen the mounting bolts for the table-down limit switch and slide the switch so the switch plunger depresses against the stop block and you hear the switch click (see **Figure 31**).
4. Re-tighten the mounting bolts.
5. Push the up arrow key and raise the table until it is $\frac{1}{8}$ " below the sanding drum.
6. Loosen the mounting bolts for the table-up limit switch, and move the switch so the switch plunger depresses against the stop block and you hear the switch click (see **Figure 31**).
7. Re-tighten the mounting bolts.
8. With the sanding belt **OFF**, use the up and down buttons to test the table operation and make sure the switches shut the table lift motor **OFF** when the table is at the minimum and maximum distance from the sanding drum.

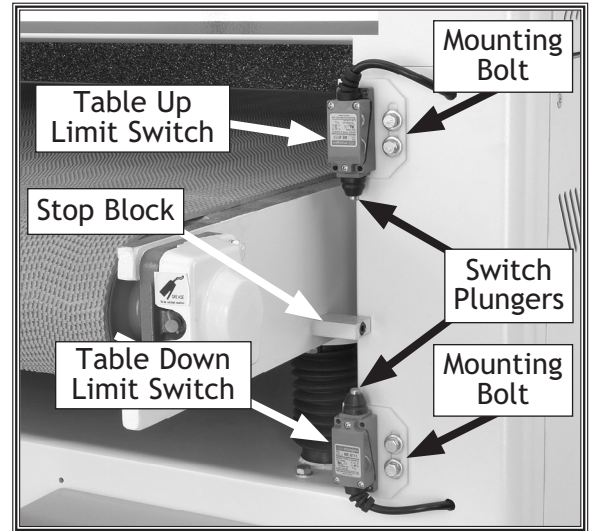

Figure 31. Table stop switch adjustment locations (right rear).

Brake Service

Eventually the brake pads will wear out. Checking and replacing these is a simple project that can be done in the shop, with the exception of having the rotor resurfaced on a lathe. The brake pads are located underneath the rotor in **Figure 32**, which is attached to the motor arbor.

To check the brake pads, do these steps:

1. DISCONNECT THE SANDER FROM THE POWER SOURCE AND REMOVE AIR PRESSURE COMPLETELY!
2. Remove the four screws that secure the access panel on the right-hand side of the machine.
3. The brake pads consist of a metal plate with a composite pad. With a fine ruler, measure the thickness of the composite pad only. If one of the pads is below $\frac{1}{8}$ " (**Figure 33**) (approximately 3mm), replace both.

To replace the brake pads, do these steps:

1. DISCONNECT THE SANDER FROM THE POWER SOURCE AND REMOVE AIR PRESSURE COMPLETELY!
2. Remove the nuts and washers from the two anchor pins on each brake caliper (**Figure 32**).
3. Remove the anchor pins, springs, and air line from each caliper bracket. The calipers should now be able to be removed.
4. Disassemble each brake caliper and remove the screws securing the brake pads.
5. Remove the brake rotor and have it professionally resurfaced at an automotive machine shop if it has gouges in it. If visible cracks are present in the brake rotor, replace it with a new one. Remove oil and dirt from the rotor with automotive brake cleaner. Once clean, only handle the rotor with a dry rag and install exactly the reverse of removal.
6. Install new brake pads, mount the caliper assembly by reversing **Steps 2-4**, and reconnect the air line.
7. Test the safety shutdown operation by running the sander and pressing the emergency stop controls.

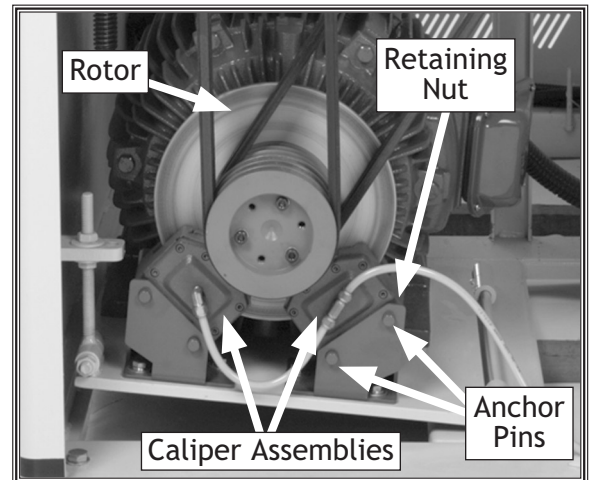

Figure 32. Disc brake assembly (Model W1757 shown).

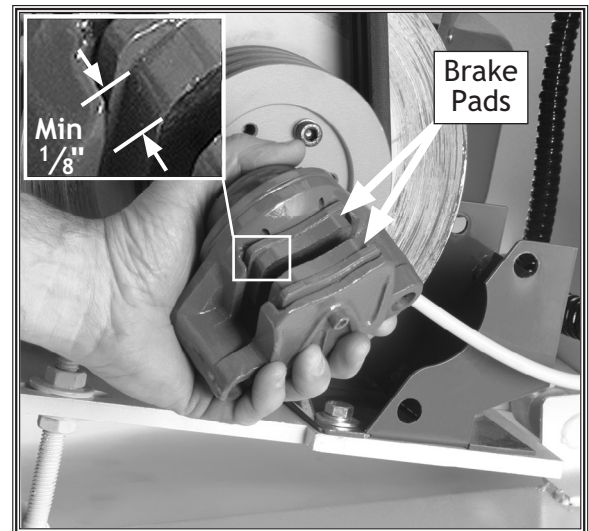

Figure 33. Example of brake caliper removed for access to brake pads.

Oscillation Timing

When the oscillation is correctly adjusted, the sanding belt oscillates to the left and to the right at the same speed. If the sanding belt makes contact with a limit switch, as shown in **Figure 34**, the emergency braking system will activate and stop the sander immediately.

To check the sanding belt oscillation, do these steps:

1. Be sure the sanding belt is properly installed and the belt tension knob is **ON**.
2. Turn **ON** the sanding belt.
 - If the belt oscillates without contacting the limit switches, but the oscillation time to the left and right are **NOT** equal, proceed to **Step 6, Page 37**.
 - If the belt tracks away from the air fork and air jet, triggering the limit switch, continue with **Step 3**.
3. An adequate stream of air through the air fork gap (**Figure 35**) is essential for proper oscillation. If the jet of air is weak through the gap, the belt will track away from the controller and into the limit switch on the opposite end of the roller. The pivot action of the upper roller, and the resulting oscillation of the belt, are dependent upon adequate airflow through the air fork gap.

To set the correct amount of airflow through the air fork gap, do these steps:

1. **DISCONNECT THE SANDER FROM THE POWER SOURCE!**
2. Remove the sanding belt, then turn the belt tension knob to the tensioned position.
3. Loosen the lock nut on the airflow adjustment knob (**Figure 36**).
4. Turn the airflow adjustment knob (**Figure 36**) clockwise until the airflow is completely **OFF**. The upper roller should pivot to the right.
5. Slowly turn the airflow adjustment knob counterclockwise, and continue turning up the air pressure until the roller pivots to the left.

Note: The basic factory setting is established by backing out the knob until it stops, then turning it 3¹/₂ turns.

NOTICE

The oscillation adjustments have been performed at the factory and should require no further attention. However, we recommend verifying the settings.

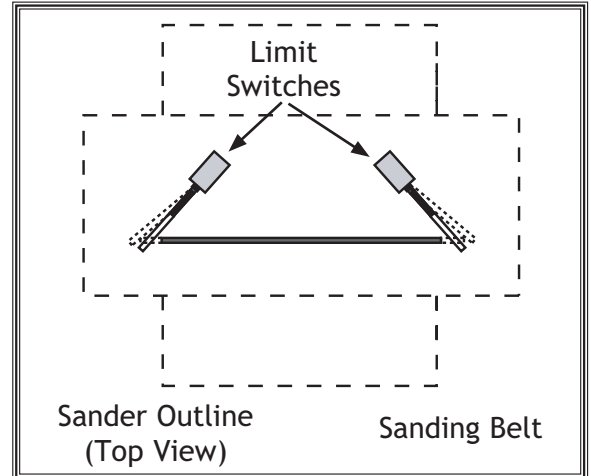

Figure 34. Improper oscillation.

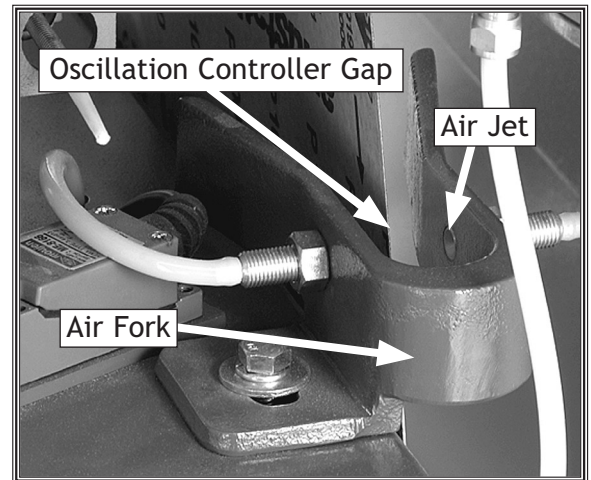

Figure 35. Air jet and air fork assembly.

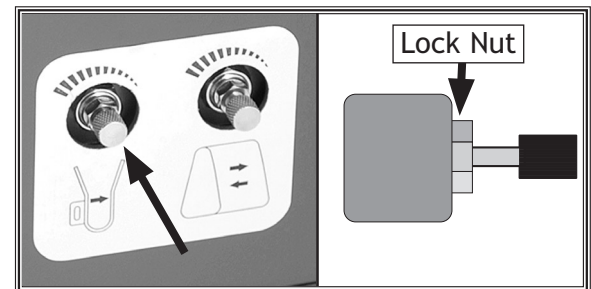

Figure 36. Airflow adjustment knob.

6. Tighten the lock nut (**Figure 36**) to secure the airflow adjustment knob.
7. Restrict the airflow across the air fork gap with a scrap piece of wood. You should notice the roller pivot to the right. When the wood scrap is removed, the roller should pivot back to the left.
8. Reinstall the sanding belt.
9. Test the oscillation by running the sander. Make note of the time it takes for the belt to oscillate from left-to-right and from right-to-left.

When correctly timed, the oscillation should take a similar amount of time to oscillate from side-to-side.

- If the oscillation time to the **right** is 2 seconds, but the oscillation time to the **left** is longer, loosen the oscillation adjustment knob (**Figure 37**) and move it to the **left** (counterclockwise) until proper tracking is achieved. Tighten down the oscillation adjustment knob when satisfied.
- If the oscillation time to the **left** is 2 seconds, but the oscillation time to the **right** is longer, loosen the oscillation adjustment knob and move it to the **right** (**clockwise**) until proper tracking is achieved. Tighten the oscillation adjustment knob when satisfied.

10. Continue to the next page to adjust the oscillation speed.

Oscillation Speed

The oscillation speed of the sanding belt is adjustable. Different oscillating speeds yield different sanding results. We recommend trying various speeds on a scrap piece of wood similar to the final workpiece.

To adjust the oscillation speed, do these steps:

1. Loosen the lock nut on the speed control adjustment knob (**Figure 38**).
2. Turn the knob clockwise to decrease the oscillation speed and counterclockwise to increase it. **Note:** To re-establish the factory setting, back out the knob until it stops, then turn it $3\frac{1}{2}$ turns.
3. Tighten the lock nut loosened in **Step 1** to secure the knob.

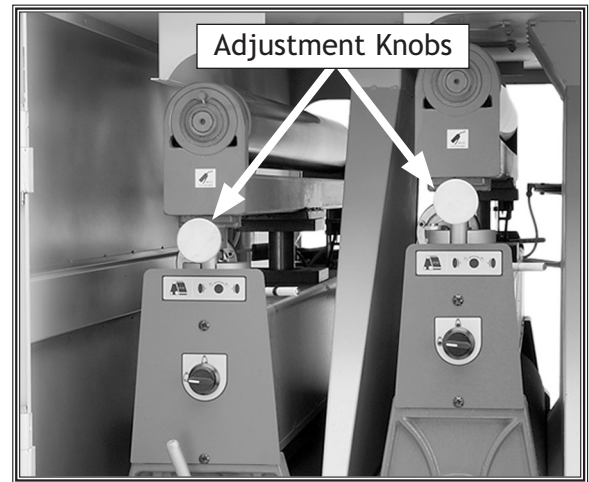

Figure 37. Oscillation adjustment knobs.

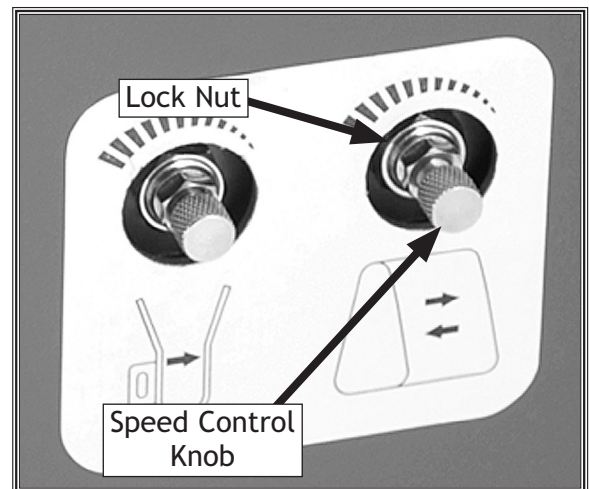

Figure 38. Speed control adjustment knob.

Table Parallelism

The corners of the table can be independently adjusted up or down. By disconnecting the chain and turning the pertinent table elevation screw sprocket (Figure 39), table parallelism can be achieved.

Adjusting the table parallelism can be a very tedious task that takes a great amount of patience. DO NOT adjust the table unless you have trouble sanding your workpiece to a uniform thickness.

If a table adjustment is needed, take precise notes on the positioning of the table elevation screws. This will allow the original setting to be re-established.

To adjust the table parallelism, do these steps:

1. Pass a 43" wide board through the sander until the entire surface of the board is making contact with the sanding belt.
2. Measure the thickness of the board at various points around the edge.
3. If there is a variation of thickness, the table can be adjusted accordingly.
4. DISCONNECT THE SANDER FROM THE POWER SOURCE!
 - For minor adjustment, loosen the table mounting bolts, shown in Figure 40, and rotate the elevation screw flange.
 - For major adjustment, mark the chain location on all sprockets, remove the chain from the sprocket to be adjusted, and turn the sprocket counterclockwise to raise the table. One quarter of a turn raises or lowers an elevation screw approximately 0.020".
5. Reinstall the chain onto the sprocket adjusted in Step 4, tighten the bolts, and test the machine.

NOTICE

The table has been adjusted at the factory and should require no further attention. However, we recommend verifying that it is parallel with the sanding roller.

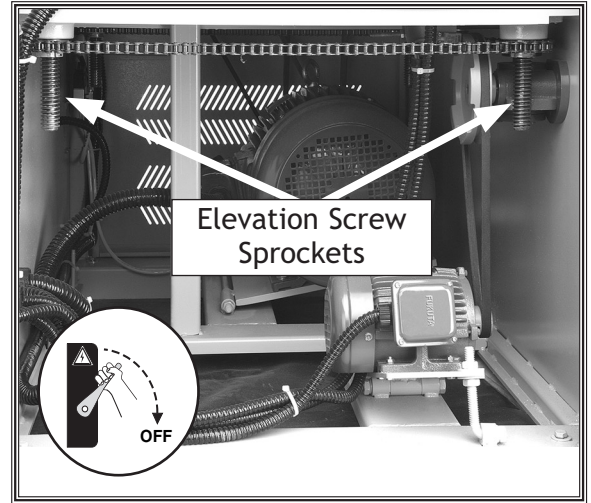

Figure 39. View of elevation screw sprockets.

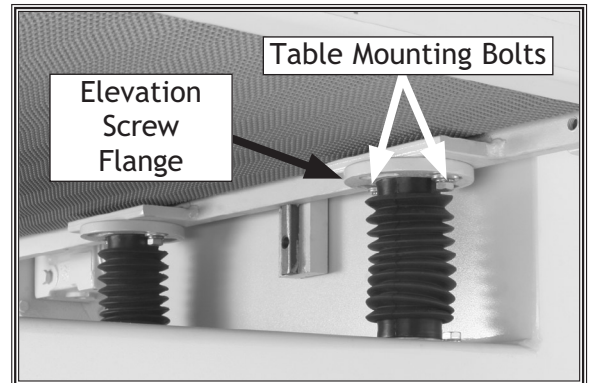

Figure 40. Table mounting bolts and elevation screw flange.

NOTICE

When adjusting the left front elevation screw, make the same adjustment to the left rear elevation screw. This ensures the height from the front to the back of the table remains unchanged. Do the same when adjusting the right elevation screws.

Pressure Rollers

To adjust the pressure rollers, do these steps:

1. DISCONNECT THE SANDER FROM THE POWER SOURCE!
2. Plane a 6' long 2x4 to a uniform thickness and cut it in half. Place one board along the length of the feed belt on the right-hand side and place the other board on the left-hand side.
3. With the sanding belt tensioned (**Figure 41**), move the sanding rollers by hand and manually raise the table until you hear the sandpaper just contact the surface of the wood. DO NOT continue to raise the table beyond that point.
4. Connect the sander to the power source and make note of the reading on the digital display. Then manually lower the table 0.020" to 0.030". This is how much lower the W1756 infeed pressure roller and W1757 front sanding drum pressure rollers should be set when compared to the sanding surface of the sanding roller.
5. DISCONNECT THE SANDER FROM THE POWER SOURCE!
6. **Model W1756:** Loosen the roller lock nuts (**Figure 42**) on both ends of the infeed pressure roller. Turn the adjustment bolts (**Figure 42**) to lower the infeed pressure roller until it just touches the board. Tighten the roller lock nuts and recheck your setting.

Note: DO NOT continue to lower the roller beyond that point.

Continued on next page 

NOTICE

The pressure rollers has been adjusted at the factory and should require no further attention. However, we recommend verifying that they are parallel with each other, the sanding drum, and the feed belt table surface.

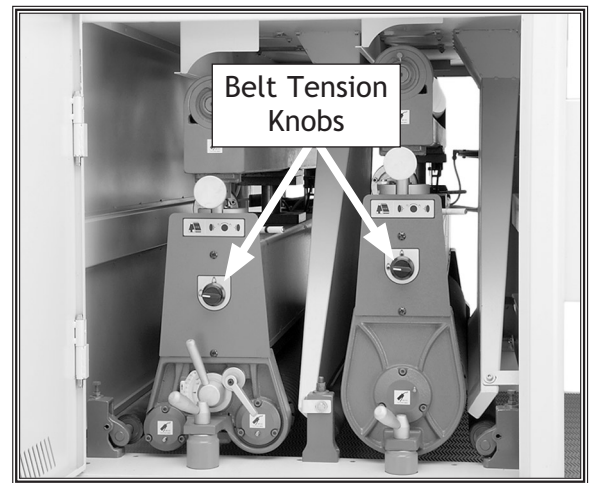

Figure 41. Belt tension knobs (W1757).

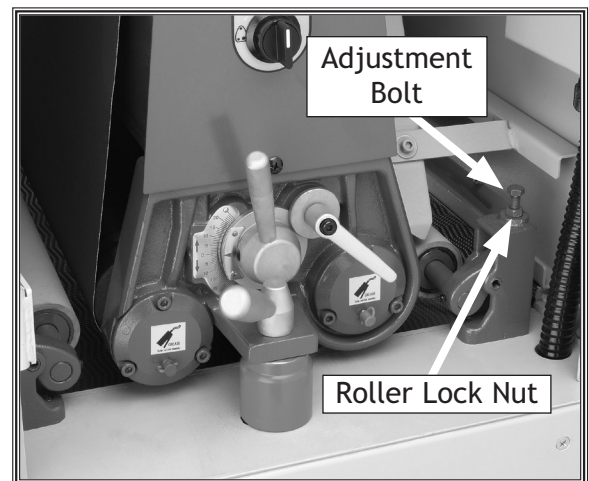

Figure 42. Infeed pressure roller adjustment location (W1756).

Model W1757: Loosen the roller lock nuts on the front sanding drum infeed and outfeed pressure rollers (Figure 43). Turn the adjustment bolts and studs on both sides of the sander to lower the infeed and outfeed pressure rollers until they just touch the board.

Note: *DO NOT continue to lower the roller beyond that point.*

7. Tighten the roller lock nuts and recheck your settings.
8. Connect the sander to the power source and make note of the reading on the digital display. Then manually lower the table an additional 0.020" to 0.030". This is how much lower the Model W1756 outfeed pressure roller or Model W1757 rear sanding drum outfeed pressure roller should be set when compared to the height of the Model W1756 infeed roller or Model W1757 front sanding drum pressure rollers.
9. DISCONNECT THE SANDER FROM THE POWER SOURCE!
10. Loosen the roller lock nuts on the Model W1756 outfeed pressure roller (Figure 44) or Model W1757 rear sanding drum outfeed pressure roller (Figure 45). Turn the adjustment bolts to lower the pressure roller until it just touches the board.

Note: *DO NOT continue to lower the roller beyond that point.*

11. Tighten the roller lock nuts and recheck your settings.

Note: *Variables such as feed rate, depth of the cut, and the type of sanding belt can play a big part in determining the proper amount of downward pressure exerted by the rollers. Some experimentation may be necessary to achieve the desired results. However, under no circumstances should the pressure rollers be set even, or higher than, the sanding roller, because this can invite kickback.*

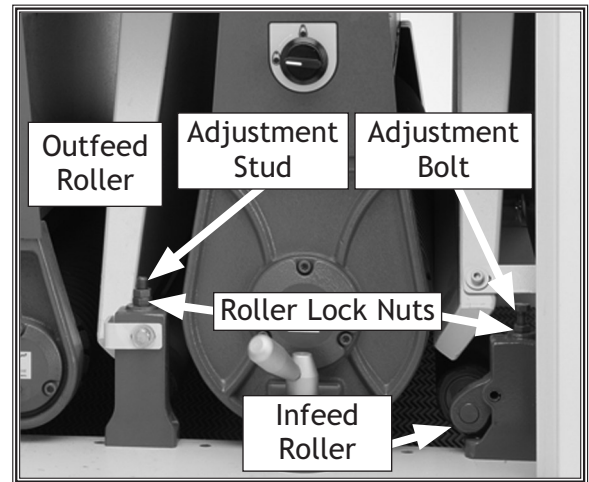

Figure 43. Front sanding drum pressure roller adjustment locations (W1757).

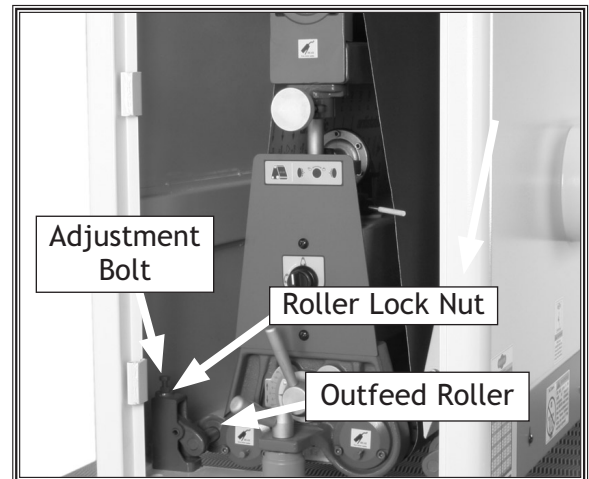

Figure 44. Outfeed pressure roller adjustment locations (W1756).

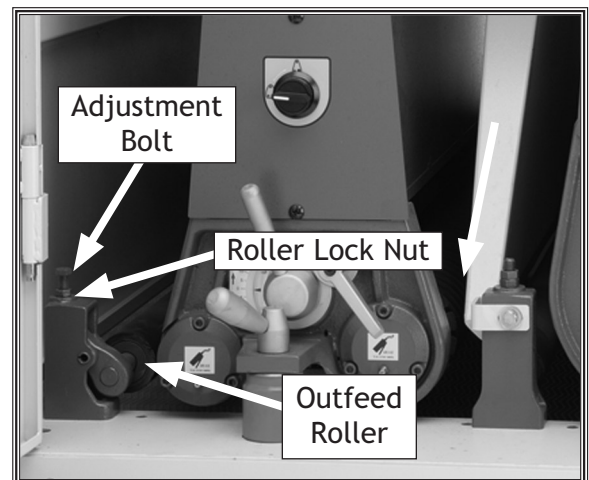

Figure 45. Rear sanding drum outfeed pressure roller adjustment locations (W1757).

V-Belt Tension

The sanding motor (Figure 46) and table elevation motor (Figure 47) V-belts must be tensioned properly for best performance. Always replace the sanding motor belts as a matched set. Both table elevation and sanding motor belts are adjusted the same way.

Note: The sanding motor belts must be tensioned correctly. Loose belts will not allow the machine to stop immediately if the emergency push panel is pushed.

The sanding motor uses a set of three matching belts. The table elevation motor uses one belt.

To adjust either V-belt, do these steps:

1. DISCONNECT THE SANDER FROM THE POWER SOURCE!
2. Loosen the lock nut (Figures 46 & 47).
3. Turn the adjustment nut up or down until the V-belts deflect $\frac{3}{4}$ " off of center when pushed with your finger, as shown in Figure 48.
4. Retighten the lock nut.

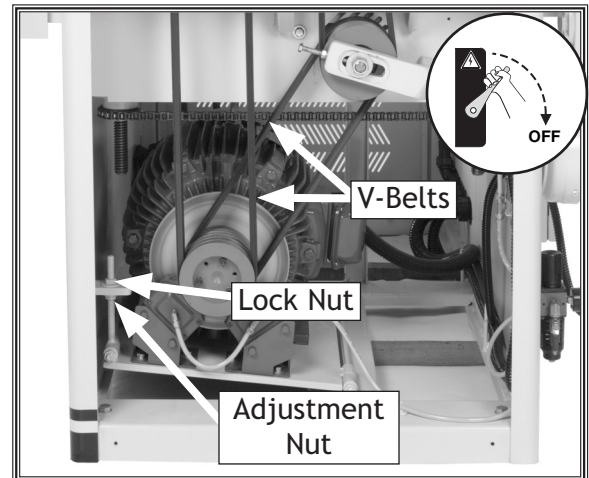

Figure 46. Sanding motor V-belts.

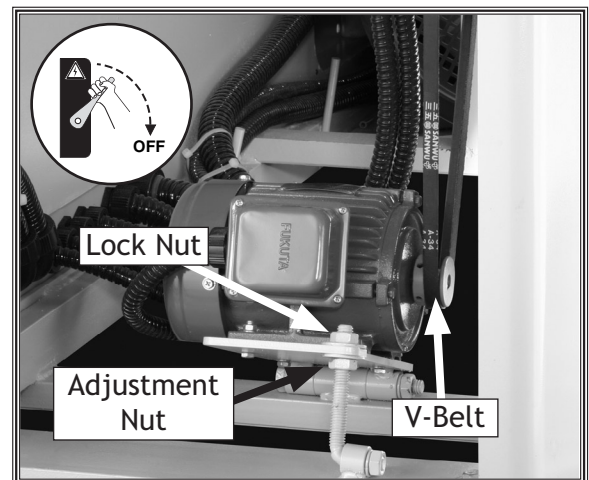

Figure 47. Table elevation V-belt.

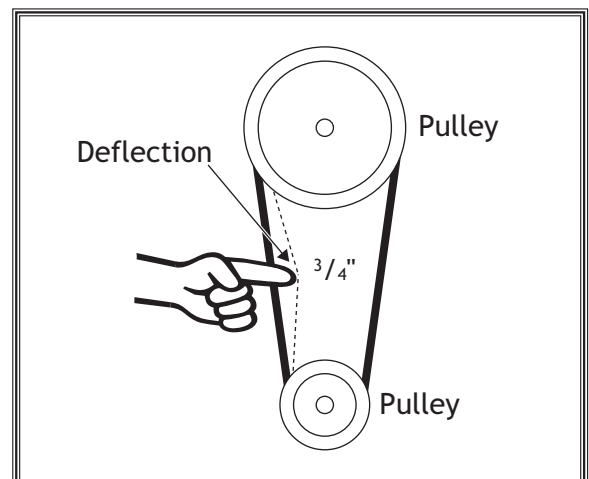

Figure 48. Belt deflection.

Changing V-Belts

Check the V-belts periodically to check for signs of glazing, cracking or fraying. If any of these conditions are present, change both V-belts.

Note: *If the emergency stop system is used to stop the machine as a normal daily event, the breaking system and belts will prematurely wear and require replacement. When shutting down the machine under non-emergency conditions, use the red OFF push buttons.*

To change the V-belts, do these steps:

1. DISCONNECT THE SANDER FROM THE POWER SOURCE AND REMOVE AIR PRESSURE COMPLETELY!
2. Open both right-side upper and lower access panels.
3. Remove the screws and the safety cover for access to the upper pulley (Figure 49 and 50).
4. Remove the upper caliper anchor pin retaining nut and washer (Figure 51) on both brake calipers.
5. Use locking pliers to clamp on the anchor pin end, pull the pin from the caliper mount, and remove the springs (Figure 51) from both brakes.
6. Pivot the calipers down and away from the rotor for belt clearance.
7. Remove the upper belt adjustment nut and washer (Figure 51).
8. Pry the motor base plate upward to de-tension the belts, and roll the belts off of the motor pulley.
9. Install the new V-belts.
10. Replace the upper belt adjustment nut and washer, and tension the belt as necessary.
11. The V-belt is properly tensioned when it will move no more than $\frac{3}{4}$ " in the center with moderate pressure from your thumb. See V-Belt Tension on Page 41 for details.
12. Reassemble in reverse order and test the emergency brake operation.

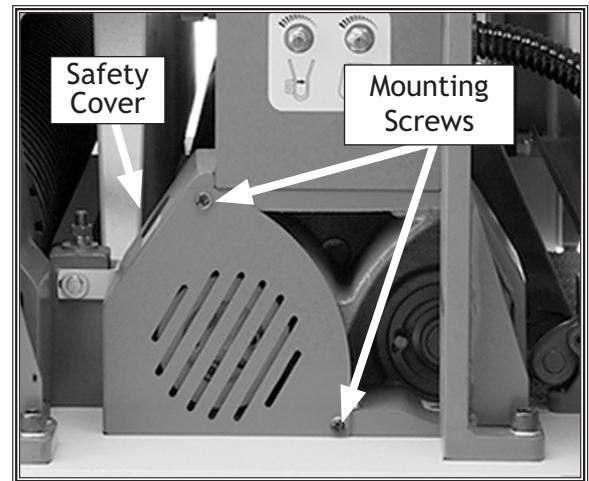

Figure 49. Safety cover and mounting screws.

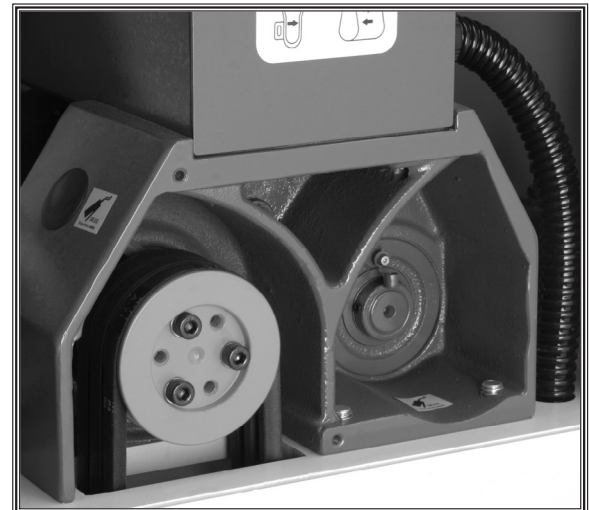

Figure 50. Upper pulley exposed.

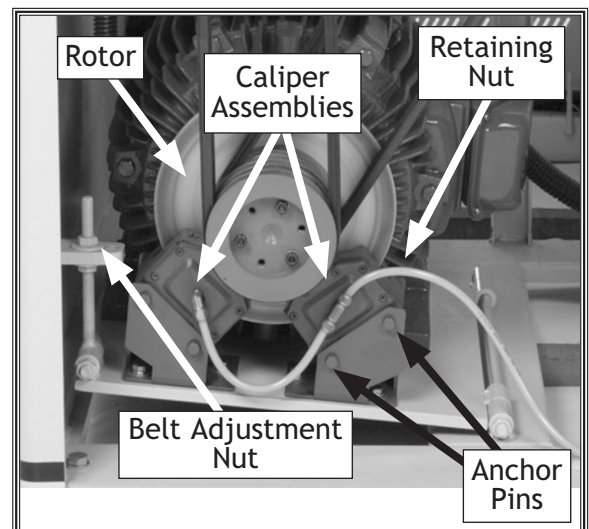

Figure 51. Belt removal access.

Feed Belt Replacement

To remove the feed belt, use Figure 53 on Page 44 and match the number with the steps below:

1. Raise the table up so the conveyor belt is approximately two-inches away from the sanding roller or platen, and then DISCONNECT THE SANDER FROM THE POWER SOURCE!
2. Remove the gearbox mounting bracket, and with an assistant's help, slide the motor and gearbox from the roller shaft and lower it to the floor.

Note: Do not loosen the two vibration dampener washers shown in **Figure 53**.

3. Remove two table height limit switches.
4. Remove both lower access panels.
5. Remove the left and right table guides.
6. Using a permanent marker, mark all four lead screw flange positions (**Figure 52**), and remove all hex bolts from the flanges.
7. Insert two 2x4x8' wooden studs under the table to support the table, and then (with help) lift the table slightly and move it out of the rear of the machine.
8. Disconnect the limit switch, remove all mounting screws, and remove the emergency stop push-panel assembly.
9. Turn both tracking adjustment bolts counter-clockwise five turns, remove one roller support, and slide the drum out of the table assembly.
10. Remove the old feed belt, inspect rollers, bearings, and table for wear and replace as required.
11. Install the new feed belt.

Note: The belt is non-directional.

12. Install the front roller, the roller support, and turn both tracking adjustment bolts clockwise equally so the conveyor belt becomes taught and does not hang loose. DO NOT OVERTIGHTEN the belt.

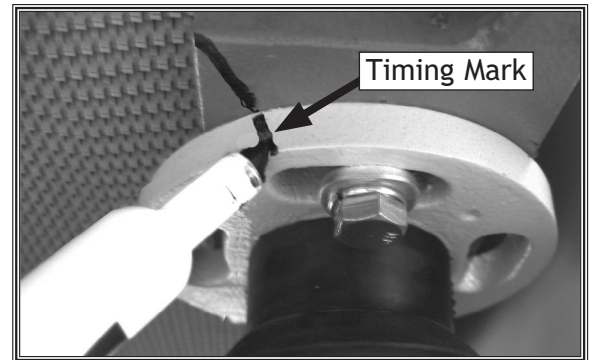

Figure 52. Marking lead screw for reassembly.

13. With a helper, install the table from the rear in a similar fashion as it was removed.
14. Install the table guides and the left and right lower access panels.
15. Align the lead screw flanges with the marks made in **Step 6**, and install the hex bolts.
16. Install and adjust the table height limit switches (refer to **Page 34**).
17. With a helper, install the gearbox, vibration dampener washers, and mounting bracket.
18. Install the emergency stop push panel assembly and the limit switch.
19. Start the conveyor motor and turn the conveyor tracking bolts as required until the conveyor belt tracks straight without loading up on one side of the table.

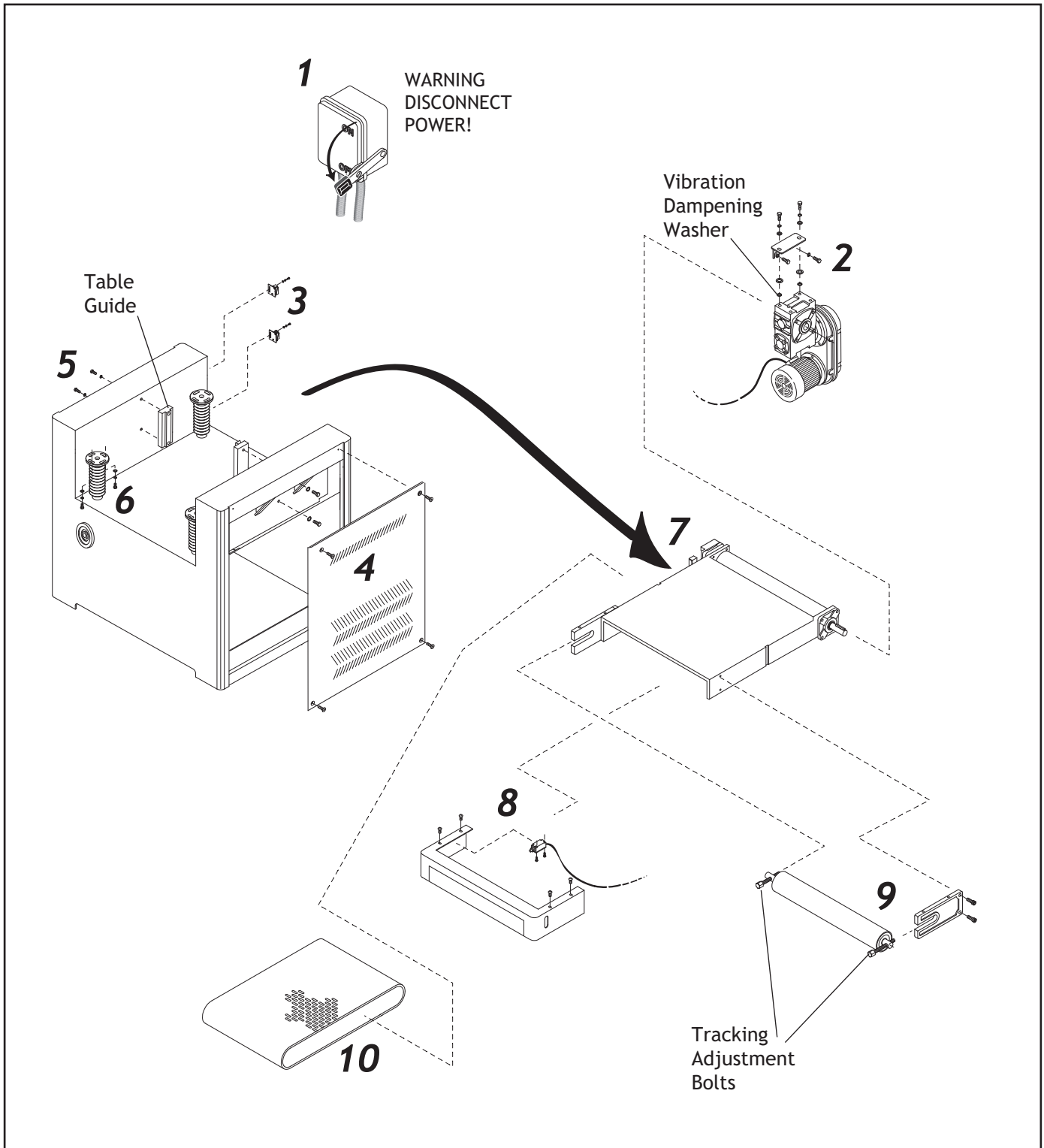

Figure 53. Conveyor belt removal sequence.

Feed Belt Tension

To adjust the feed belt tension, do these steps:

1. DISCONNECT THE SANDER FROM THE POWER SOURCE!
2. Do not remove the safety guard!
3. Find the adjustment ports in the safety guard (Figure 54) at the front end of the feed table.
4. Using a 20mm wrench, turn both left and right adjustment bolts (Figure 54) clockwise equally to increase tension.
5. When tensioned properly, you should not be able to slide the feed belt back and forth on the table surface.

Sanding Belt Replacement

To replace the sanding belts, do these steps:

1. Follow Steps 1-3 on Page 19.
2. Making sure the rotation arrows on the sanding belt point the same direction as those shown in Figure 11, remove the sanding belt and install the new sanding belt by starting first on the upper roller, and then the lower roller.

Note: *The sanding belt must be centered between the limit switches and the edge of the sanding belt must be between tongs of the oscillation controller as shown in Figure 12 on Page 19. Damage to the sanding belt could occur if the sander is turned ON before the sanding belt is correctly positioned.*

NOTICE

The directional arrow on the back of the sanding belt must be pointing in a counterclockwise direction during installation. Failure to install the sanding belt correctly could result in damage to the sanding belt or the sander itself.

3. Follow Steps 6-7 on Page 19.

NOTICE

The feed belt tension has been adjusted at the factory and should require no further attention. However, adjust the feed belt tension if you notice that your feed belt is slipping or is tracking off center.

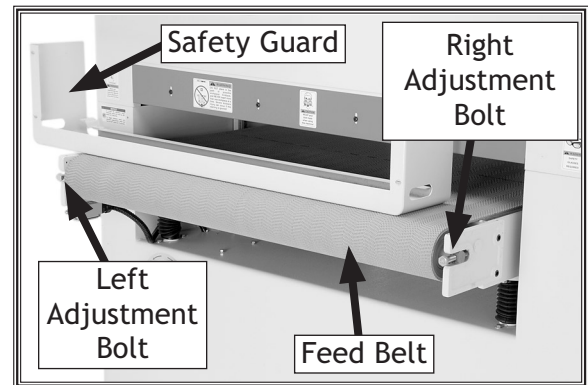

Figure 54. Feed belt tension adjustment bolts. **Note:** *Safety guard removed only for clarity.*

⚠ WARNING

DO NOT sand boards with the guard removed. Failure to follow this warning could result in serious personal injury.

Feed Belt Tracking

To adjust the feed belt tracking, do these steps:

1. Turn the feed belt *ON*.
2. If the feed belt is tracking to the **right** side of the table, turn the **right** adjustment bolt (**Figure 54**) clockwise.
3. If the feed belt is tracking to the **left** side of the table, turn the **left** adjustment bolt clockwise.

Note: *The edge of the feed belt should just touch the guide wheels, as shown in **Figure 55**.*

4. Run the feed belt for 3-5 minutes and recheck the tracking.

Sanding Belt Tracking Limit Switches

Sanding belt tracking safety switches are placed on both sides of the belt to act as emergency machine stops if the belt travels too far to one side during oscillation (see **Figure 56**).

To adjust the belt tracking safety switches, do these steps:

1. **DISCONNECT THE SANDER FROM THE POWER SOURCE!**
2. Make sure the sanding belt tracking and oscillation is adjusted (See **Page 36**).
3. Release the belt tension, center the sanding belt on the top roller, then re-tension the belt.
4. Measure the distance from the edge of the sanding belt to the ceramic rod protruding from the switch.
5. Loosen the adjustment bolt shown in **Figure 56**, and move the switch so the belt and the ceramic rod have approximately 1/2" clearance from each other.
6. Tighten the bolt and repeat the adjustment with the other side if necessary.
7. Start the sander and make sure it is working properly.

NOTICE

Adjust the feed belt tension before adjusting the feed belt tracking.

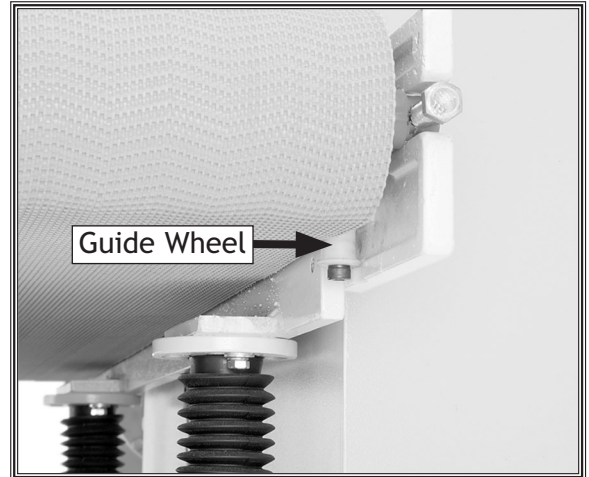

Figure 55. Guide wheel (one shown).

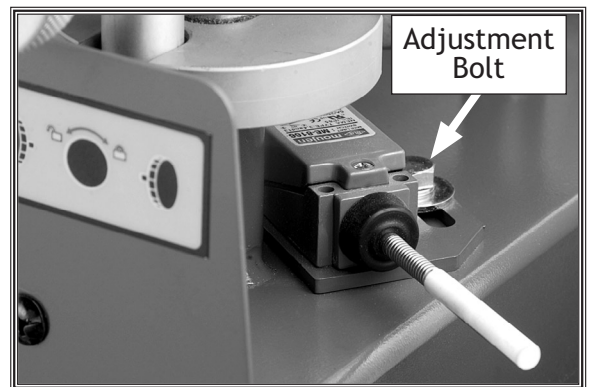

Figure 56. Tracking safety switch adjustment bolt.

Sanding Belt Tension Safety Switch

The belt tension safety switch shuts the sanding motor **OFF** if the belt breaks or has no tension when the lock flange pushes the belt tension safety switch lever (see Figures 57 & 58).

To adjust the belt tension safety switch, do these steps:

1. DISCONNECT THE SANDER FROM THE POWER SOURCE!
2. Apply normal system air pressure of 75 PSI, and tension the belt.
3. Loosen the mounting screw and position the switch so the lever is in the center of the lock flange hole.
4. Re-tighten the screw and test the switch operation.

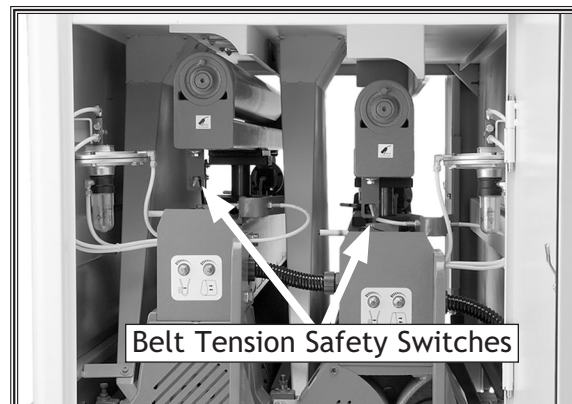

Figure 57. Belt tension safety switch location (W1757).

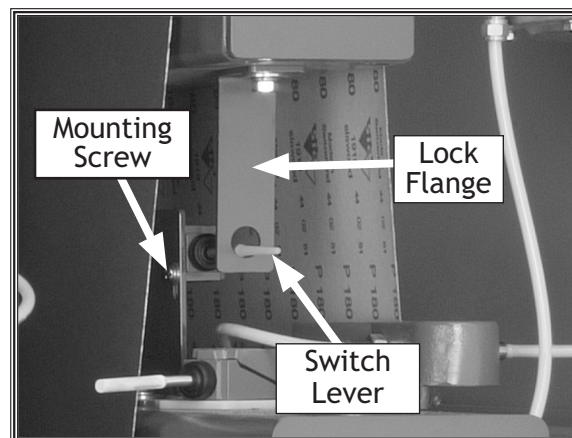
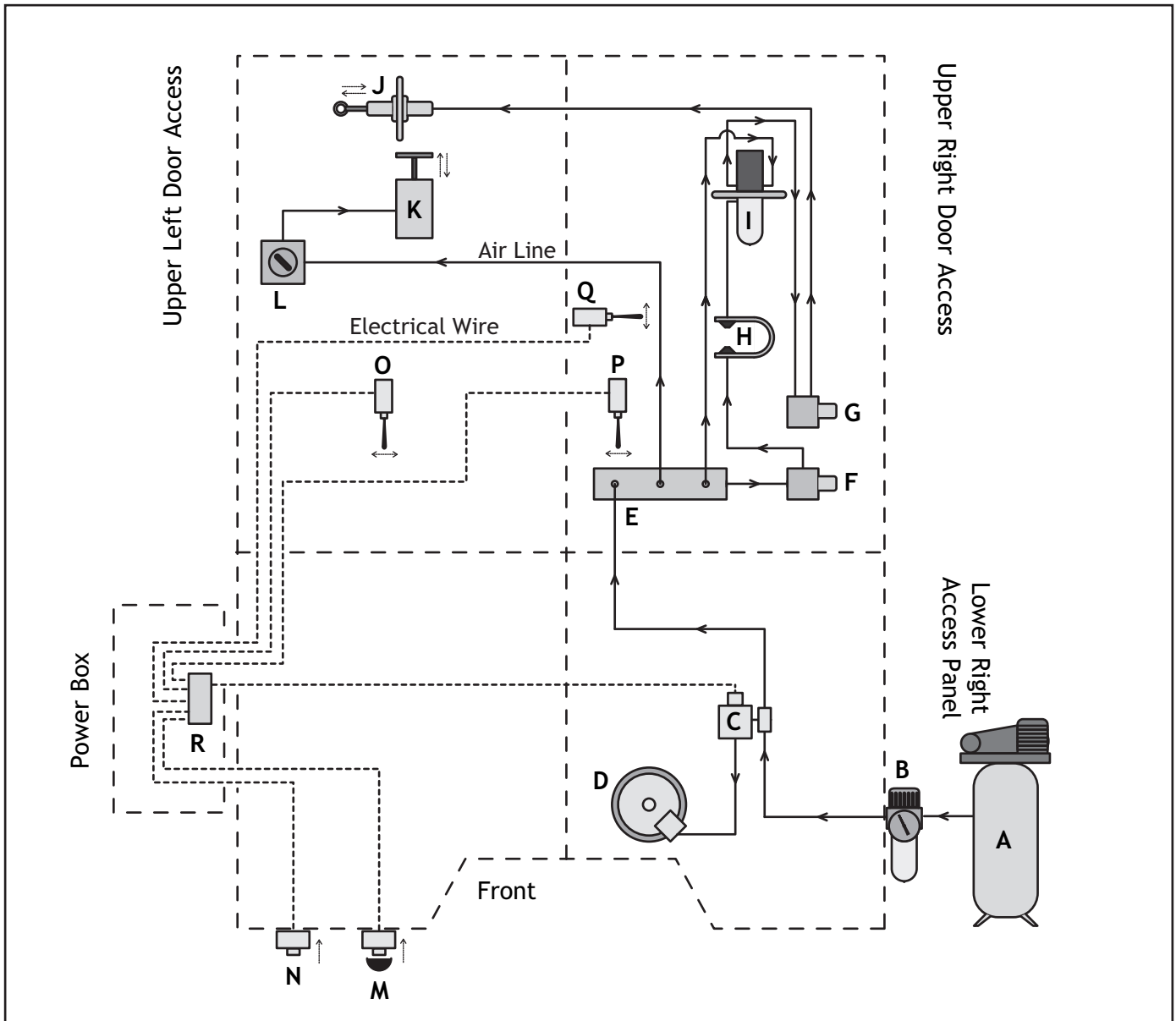

Figure 58. Belt Tension safety switch (W1756).

Air System Diagram

- A. Shop Compressor
- B. Air Pressure Regulator
- C. Emergency Brake Solenoid
- D. Emergency Brake
- E. Air Distribution Manifold
- F. Airflow Adjustment Knob (Oscillation Timing)
- G. Speed Control Adjustment Knob (Oscillation Speed)
- H. Oscillation Controller Air Fork
- I. Oscillation Timing Piston and Diaphragm Assembly
- J. Oscillation Speed Control Piston
- K. Belt Tension Control Piston
- L. Belt Tension Control Switch
- M. Emergency Stop Button Switch
- N. Emergency Stop Push Brake Switch
- O. Left Belt Limit Switch
- P. Right Belt Limit Switch
- Q. Belt Tension Limit Switch
- R. Emergency Brake Contactor



Note: Both Model W1757 sanding heads operate on separate, but identical air systems.

SERVICE

General Control Panel Wiring

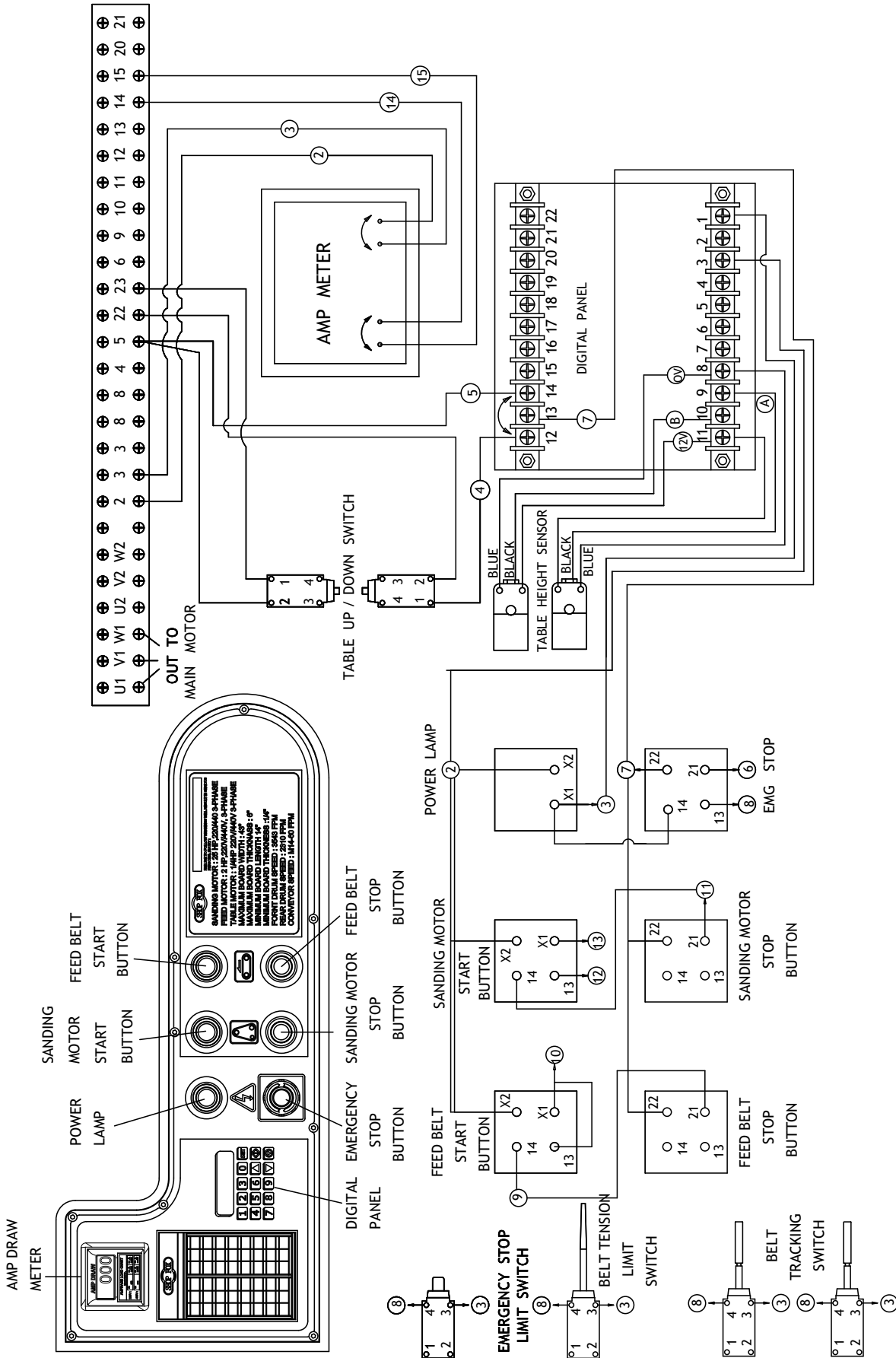

Wiring Box Electrical Diagram 220V

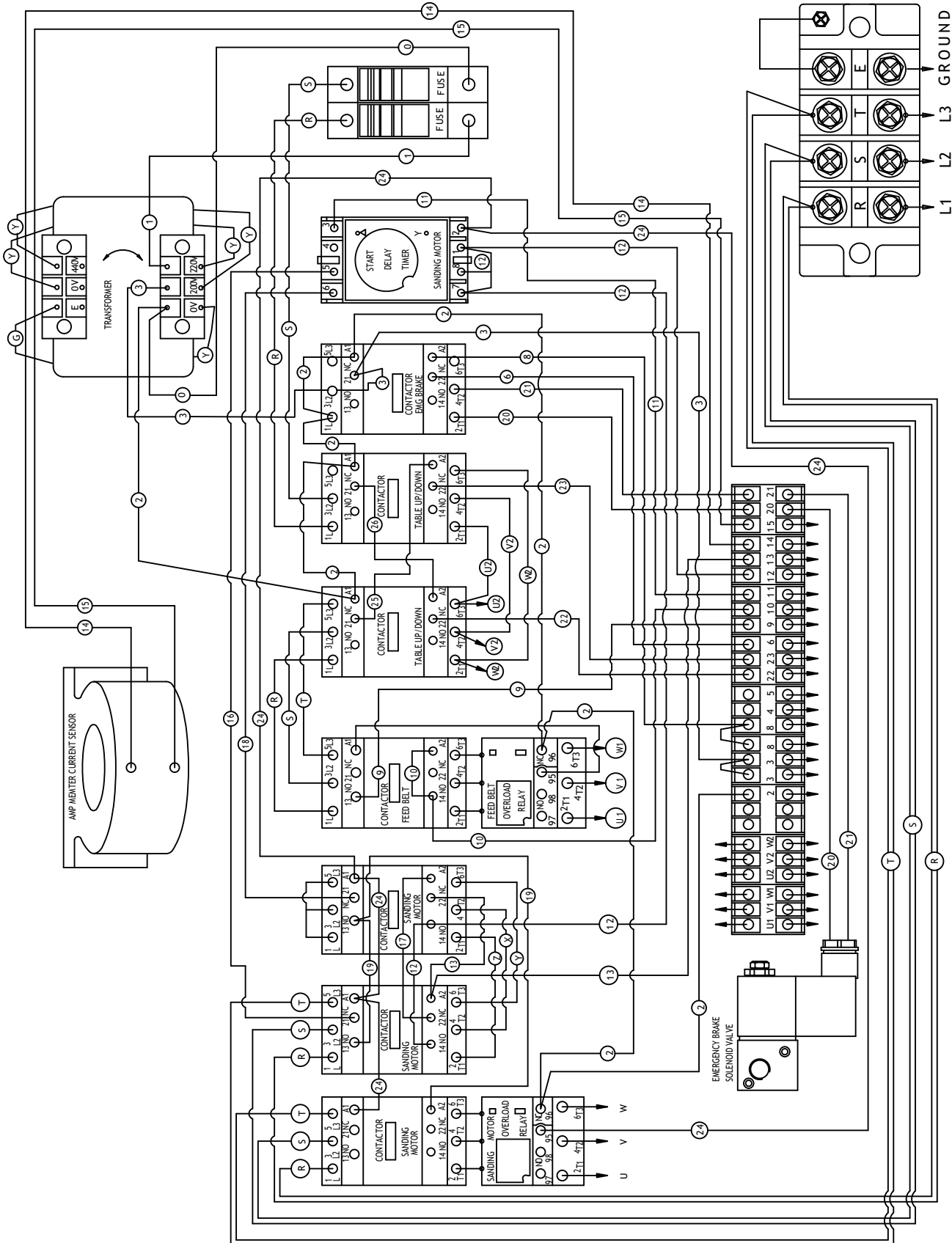

NOTE: Phase Converter Wild Wire Connects To The S Terminal Only. See Page 14.

SERVICE

Wiring Box Components 220V

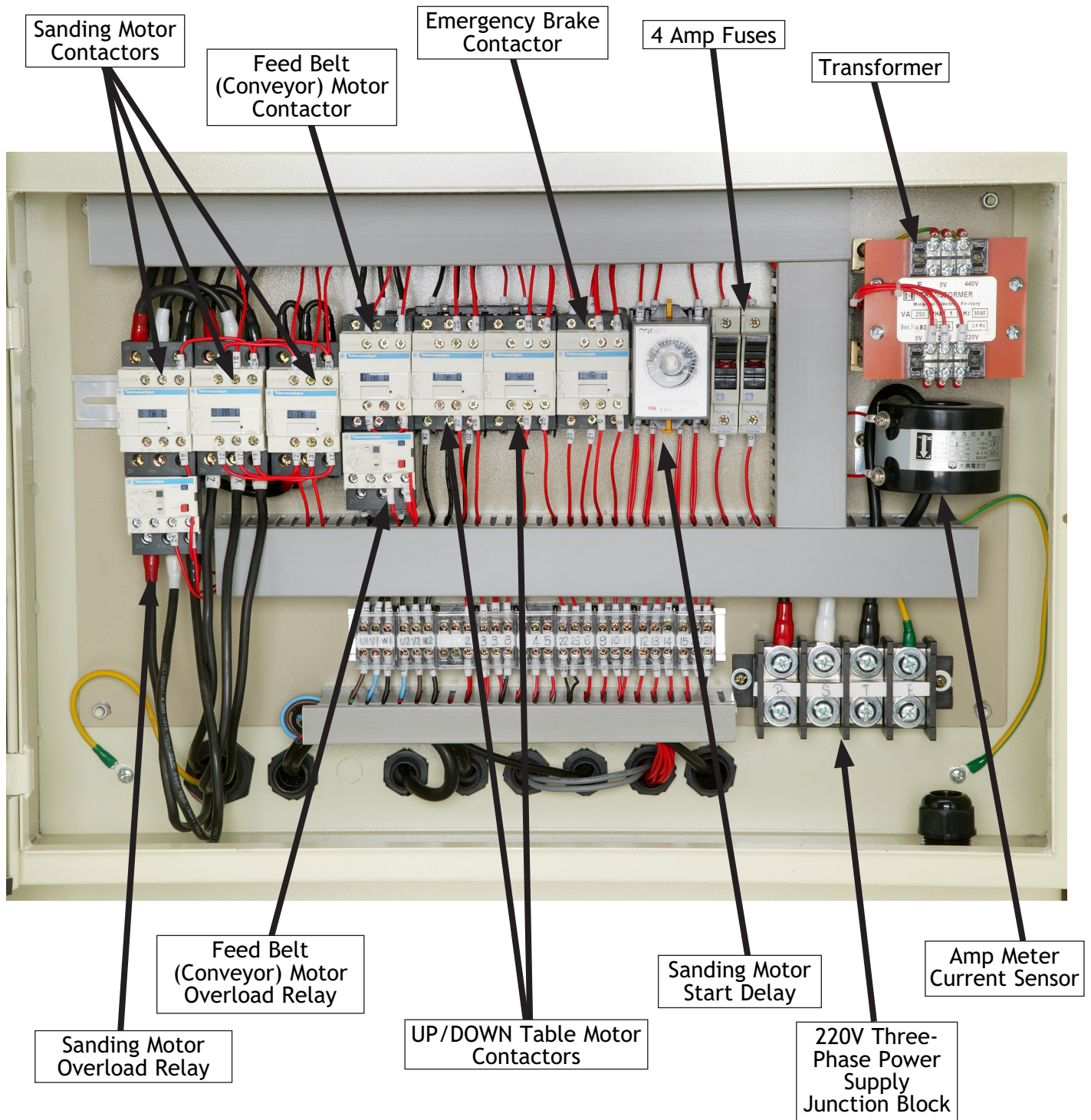

SERVICE

General Electric Diagram (W1756) 220V

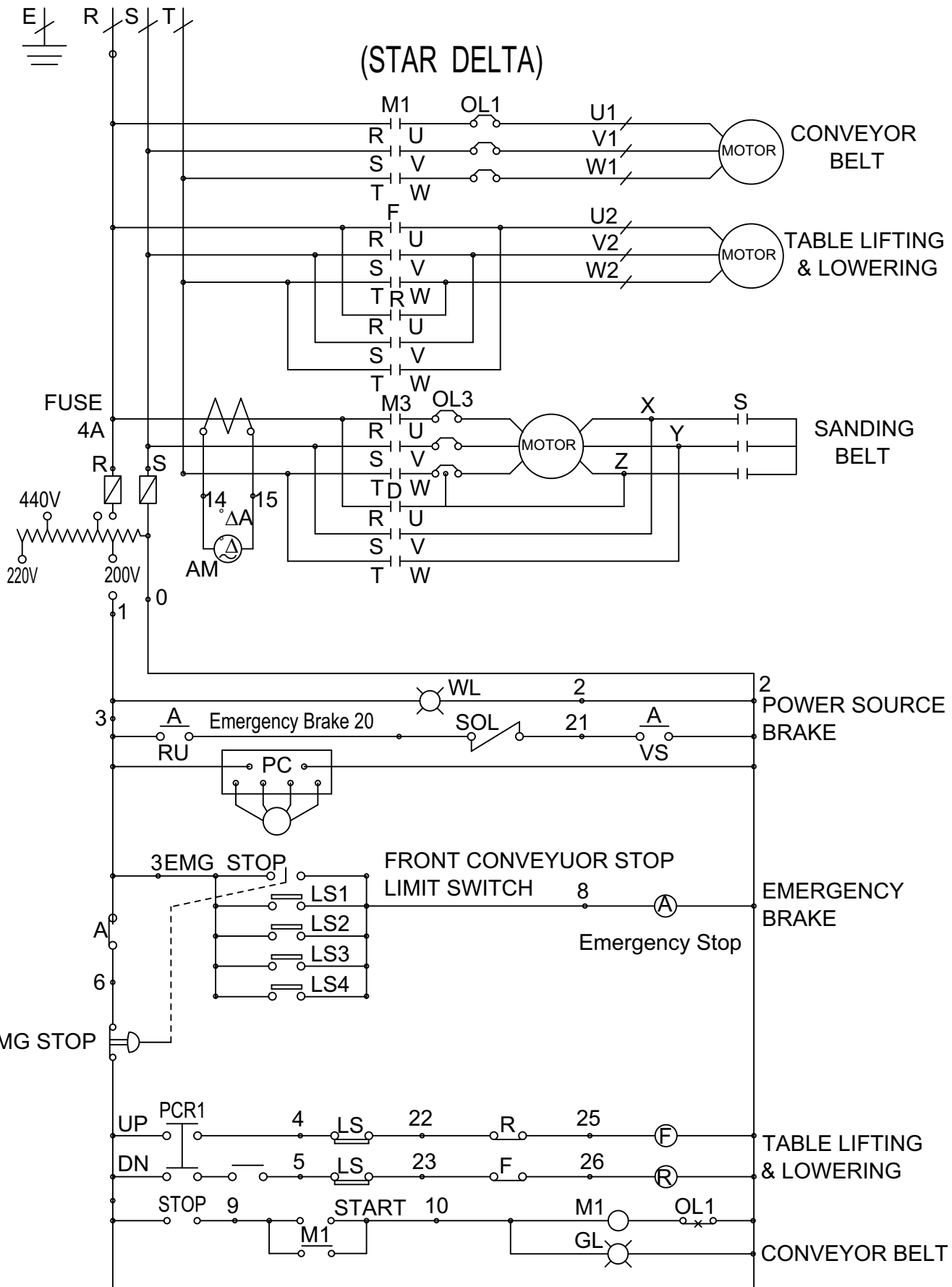

SERVICE

General Electric Diagram (W1757) 220V

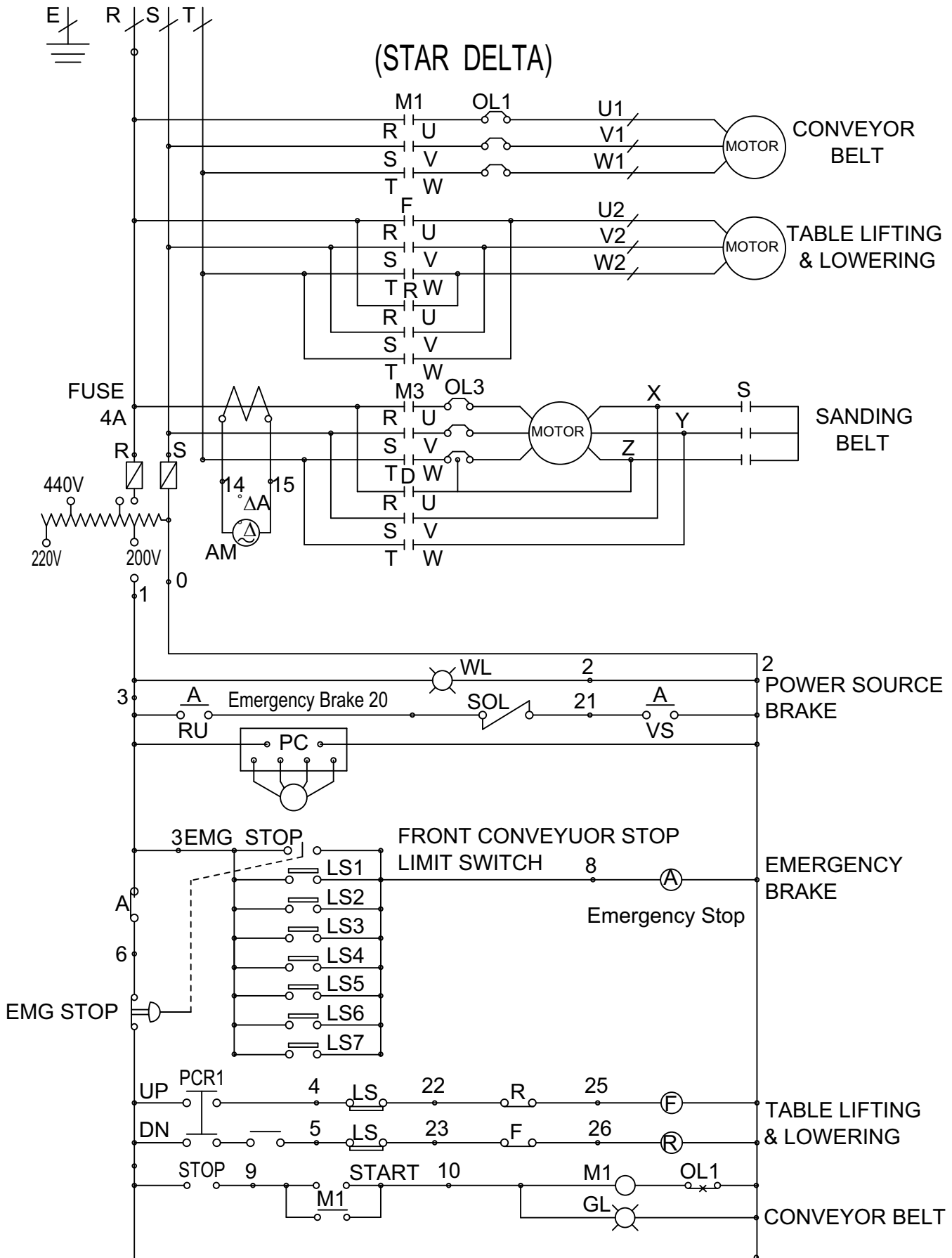

SERVICE

Motor and Transformer Connection

W1756/W1757 220V Three-Phase Motor/Transformer Connection †

† Power Supply Phase Converter Installation May Be Required—Consult Your Electrician.

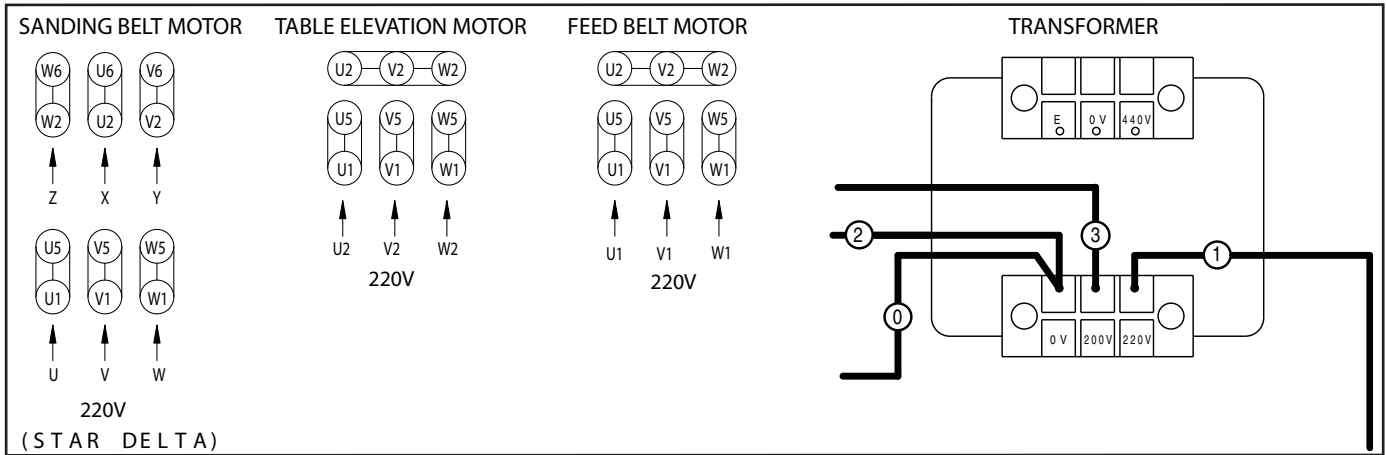

W1756/W1757 440V Three-Phase Motor/Transformer Connection ††

†† Thermal Overload Relay Replacement Required—Consult Your Electrician.

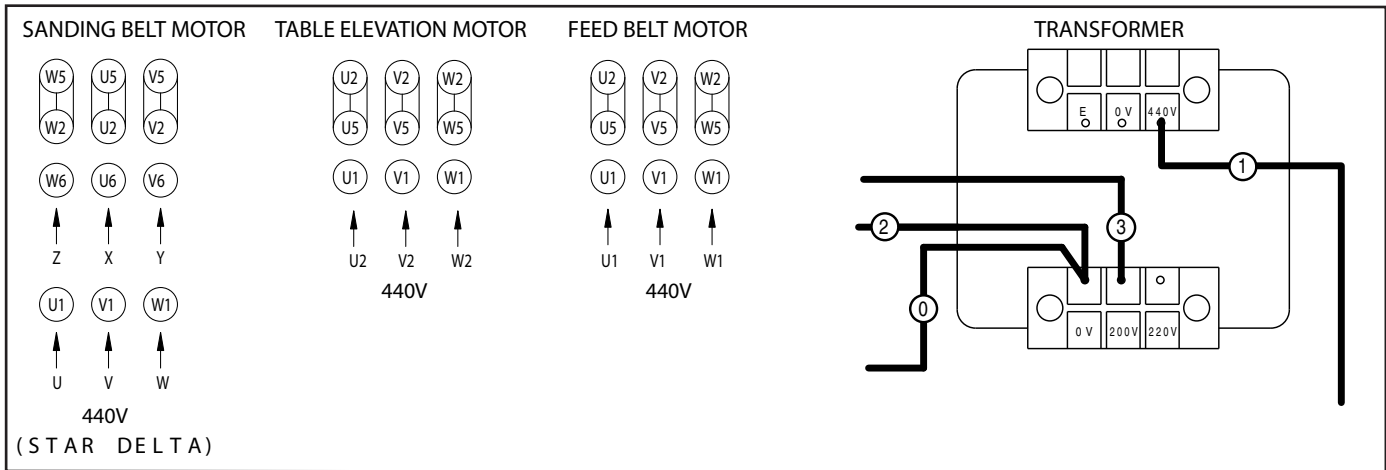

Rewiring W1756 and W1757 for 440V:

1. DISCONNECT POWER, remove the LR3D-356 overload relay, and replace it with an LR3D-216 type (Model W1756/W1757 Part #X1756037-1), and the dial set to 16A.
2. Remove the LR3D-126 overload relay, and replace it with an LR3D-086 type (Model W1756/W1757, Part # X1756037-2), and set the dial set to 3A.

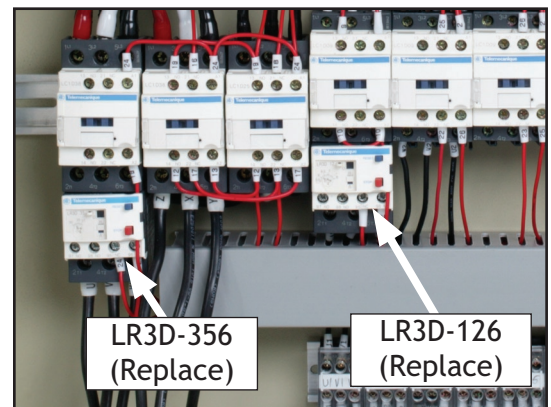

Troubleshooting

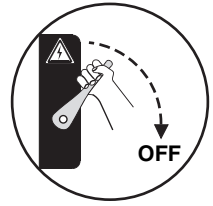

This section covers the most common problems and corrections with this type of machine. **WARNING! DO NOT** make any adjustments until power is disconnected and moving parts have come to a complete stop!

Motor & Electrical

Motor & Electrical

PROBLEM	POSSIBLE CAUSE	CORRECTIVE ACTION
Motor will not start.	<ol style="list-style-type: none"> 1. Limit switch or emergency stop is at fault. 2. Low voltage. 3. Open circuit in motor or loose connections. 4. No air pressure to sander. 	<ol style="list-style-type: none"> 1. Correct situation that caused limit switch to engage, reset the emergency stop button. 2. Check power line for proper voltage. 3. Inspect all lead connections on motor for loose or open connections. 4. Connect sander to compressed air system (Page 18).
Motor will not start; fuses or circuit breakers blow.	<ol style="list-style-type: none"> 1. Short circuit in line cord or plug. 2. Short circuit in motor or loose connections. 3. Incorrect fuses or circuit breakers in power line. 	<ol style="list-style-type: none"> 1. Inspect cord or plug for damaged insulation and shorted wires. 2. Inspect all connections on motor for loose or shorted terminals or worn insulation. 3. Install correct fuses or circuit breakers.
Motor overheats.	<ol style="list-style-type: none"> 1. Motor overloaded. 2. Air circulation through the motor restricted. 	<ol style="list-style-type: none"> 1. Reduce load on motor (see Page 25). 2. Clean out motor to provide normal air circulation.
Motor stalls (resulting in blown fuses or tripped circuit)	<ol style="list-style-type: none"> 1. Short circuit in motor or loose connections. 2. Low voltage. 3. Incorrect fuses or circuit breakers in power line. 4. Motor overloaded. 	<ol style="list-style-type: none"> 1. Inspect connections on motor for loose or shorted terminals or worn insulation. 2. Correct the low voltage conditions. 3. Install correct fuses or circuit breakers. 4. Reduce load on motor (see Page 25).

Machine Operations

PROBLEM	POSSIBLE CAUSE	CORRECTIVE ACTION
Machine slows when operating.	<ol style="list-style-type: none"> 1. Feed rate too high. 2. Depth of cut too great. 	<ol style="list-style-type: none"> 1. Feed workpiece slower (see Pages 24). 2. Reduce depth of cut (see Page 28).
Loud, repetitious noise coming from machine.	<ol style="list-style-type: none"> 1. Pulley set screws or keys are missing or loose. 2. Motor fan is hitting the cover. 3. V-belt is defective. 	<ol style="list-style-type: none"> 1. Inspect keys and set screws. Replace or tighten if necessary. 2. Tighten fan or shim cover. 3. Replace V-belt (see Page 42).
Machine is loud, overheats or bogs down in the cut.	<ol style="list-style-type: none"> 1. Excessive depth of cut. 2. Dull or dirty sanding belt. 	<ol style="list-style-type: none"> 1. Decrease depth of cut (see Page 28). 2. Replace or clean sanding belt (see Pages 30 & 45).
Rounded workpiece edges.	<ol style="list-style-type: none"> 1. Excessive depth of cut. 	<ol style="list-style-type: none"> 1. Reduce depth of cut (see Page 28).
Uneven thickness from left to right of board.	<ol style="list-style-type: none"> 1. Feed table not parallel to sanding roller. 2. Feed belt is worn. 	<ol style="list-style-type: none"> 1. Adjust the table (see Page 38). 2. Replace feed belt (see Page 43).
Workpiece slips on feed belt.	<ol style="list-style-type: none"> 1. Pressure rollers set too high. 2. Dirty feed belt. 3. Feed belt is worn. 	<ol style="list-style-type: none"> 1. Lower pressure rollers (see Page 39). 2. Clean feed belt (see Page 30). 3. Replace feed belt (see Page 43).
Straight strip of notches on workpiece.	<ol style="list-style-type: none"> 1. Pressure rollers are dirty or damaged. 	<ol style="list-style-type: none"> 1. Clean or repair pressure rollers.
Snake shaped marks on workpiece.	<ol style="list-style-type: none"> 1. Sanding belt damaged or dirty. 	<ol style="list-style-type: none"> 1. Clean or replace sanding belt (see Pages 30 & 45).

Machine Operations (continued)

PROBLEM	POSSIBLE CAUSE	CORRECTIVE ACTION
Lines across width of workpiece.	1. Sanding belt seam is open or damaged.	1. Repair or replace sanding belt (see Page 45).
Glossy spots or streaks on workpiece.	1. Worn sanding belt. 2. Rear pressure roller too low.	1. Replace sanding belt (see Page 45). 2. Raise rear pressure roller. (See warning in Pressure Roller section, Page 20!)
Sanding belt clogs quickly.	1. Sanding belt grit too small for particular job. 2. Excessive depth of cut. 3. Wood is too moist.	1. Replace with a coarser grit sanding belt. 2. Reduce depth of cut (see Page 28). 3. Allow wood to dry out.
Sanding belt does not tension correctly; rollers slip under belt.	1. Low air pressure. 2. Air leaks in system.	1. Adjust air pressure to 75 PSI at primary regulator (see Page 31). 2. Inspect all hoses and connections for leaking air; use water on suspected area to detect bubbles.
Sanding belt runs off to one side, stopping the sander.	1. Air eye fork clogged. 2. Oscillation return valve closed. 3. Oscillation timing incorrect.	1. Clean the intake hole on the air eye fork. 2. Open valve. 3. Adjust oscillation timing (see Page 36).
Sanding belt will not start.	1. Sanding belt is not tensioned. 2. Limit switches engaged. 3. Emergency stop plate engaged. 4. No air pressure to sander.	1. Tension sanding belt (see Page 19). 2. Center sanding belt so it is not touching the limit switches (see Page 46). 3. Make sure emergency stop plate is released (see Page 26). 4. Connect sander to compressed air system (Page 18)
Poor, non-aggressive sanding results.	1. Worn sanding belt. 2. Sanding belt loaded with sawdust.	1. Replace sanding belt with a new one (see Page 45). 2. Clean sanding belt to unload sawdust (see Page 30).
Feed belt not tracking in center.	1. Feed belt moved out of adjustment.	1. Adjust feed adjustment bolts (see Page 46).
Feed belt slipping.	1. Feed rollers have incorrect tension. 2. Feed rollers contaminated with dirt or dust.	1. Adjust feed rollers to place more tension on the workpiece (see Page 45). 2. Clean feed rollers.
Emergency brake stops slow.	1. Air pressure incorrect. 2. Air leak in system. 3. Brake rotor contaminated with oil. 4. Brake pads worn out.	1. Adjust air pressure to 75 PSI (see Page 31). 2. Find and fix air leaks. 3. Clean brake rotor with automotive brake parts cleaner. 4. Replace brake pads (see Page 35).
Grinding noise when braking.	1. Brakes severely worn out.	1. Replace brake pads (Page 35), have rotor turned (possibly replaced).

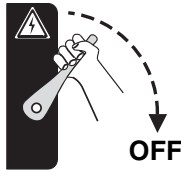

! WARNING

For your safety, turn the power switch off and disconnect the sander from the power source and the air supply before starting the applicable troubleshooting.

PARTS

Electrical & Controls

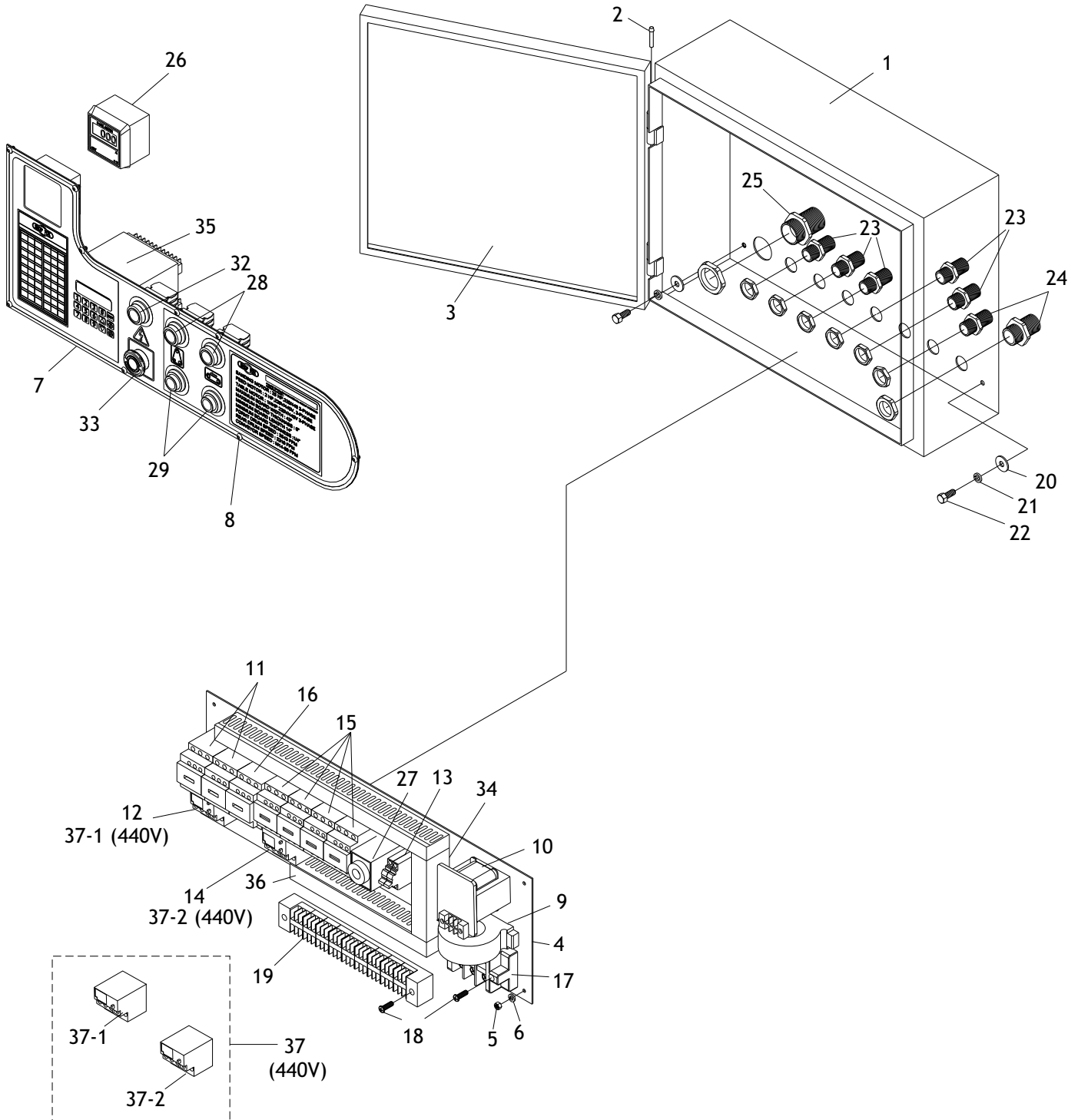

Electrical & Controls Parts List

REF PART #	DESCRIPTION
1	X1756001 ELECTRICAL CONTROL BOX
2	X1756002 HINGE
3	X1756003 DOOR
4	X1756004 BASE PLATE
5	XPN05 HEX NUT 1/4-20
6	XPLW02 LOCK WASHER 1/4
7	X1756007 CONTROL PANEL
8	XPS07M PHLP HD SCR M4-.7 X 8
9	X1756009 CURRENT SENSOR
10	X1756010 TRANSFORMER
11	X1756011 MAGNETIC CONTACTOR LC1-D386
12	X1756012 OVERLOAD RELAY LR3D-356 (30-38A) 220V 32A
13	X1756013 FUSE TE10.3 X 38 & 500V / 4A X 2
14	X1756014 OVERLOAD RELAY LR3D-126 (5.5-8A) 220V 6A
15	X1756015 MAG CONTACTOR LC1-096 (W/LOCK)
16	X1756016 MAGNETIC CONTACTOR LC1-D326
17	X1756017 POWER WIRE TERMINAL

REF PART #	DESCRIPTION
18	XPS51M PHLP HD SCR M4-.7 X 30
19	X1756019 TERMINAL PLATE
20	XPW06 FLAT WASHER 1/4
21	XPLW02 LOCK WASHER 1/4
22	XPB19 HEX BOLT 1/4-20 X 1/2
23	X1756023 PU CONNECTOR 1/2"
24	X1756024 PU CONNECTOR 3/4"
25	X1756025 CABLE CONNECTOR 1"
26	X1756026 DIGITAL AMP METER
27	X1756027 START DELAY TIMER LSD
28	X1756028 START SWITCH
29	X1756029 STOP SWITCH
32	X1756032 POWER INDICATION LIGHT
33	X1756033 EMERGENCY STOP SWITCH
34	X1756034 WIRE COLUMN
35	X1756035 COMPUTER
36	X1756036 WIRE COLUMN

W1756/W1757 440 Conversion Kit

37	X1756037	220V-440V CONVERSION KIT
37-1	X1756037-1	RELAY LR3D-216 (12-18A) #8112 440V 25HP
37-2	X1756037-2	RELAY LR3D-086 (2.5-4A) #8114 440V 1HP

Tools & Cabinet

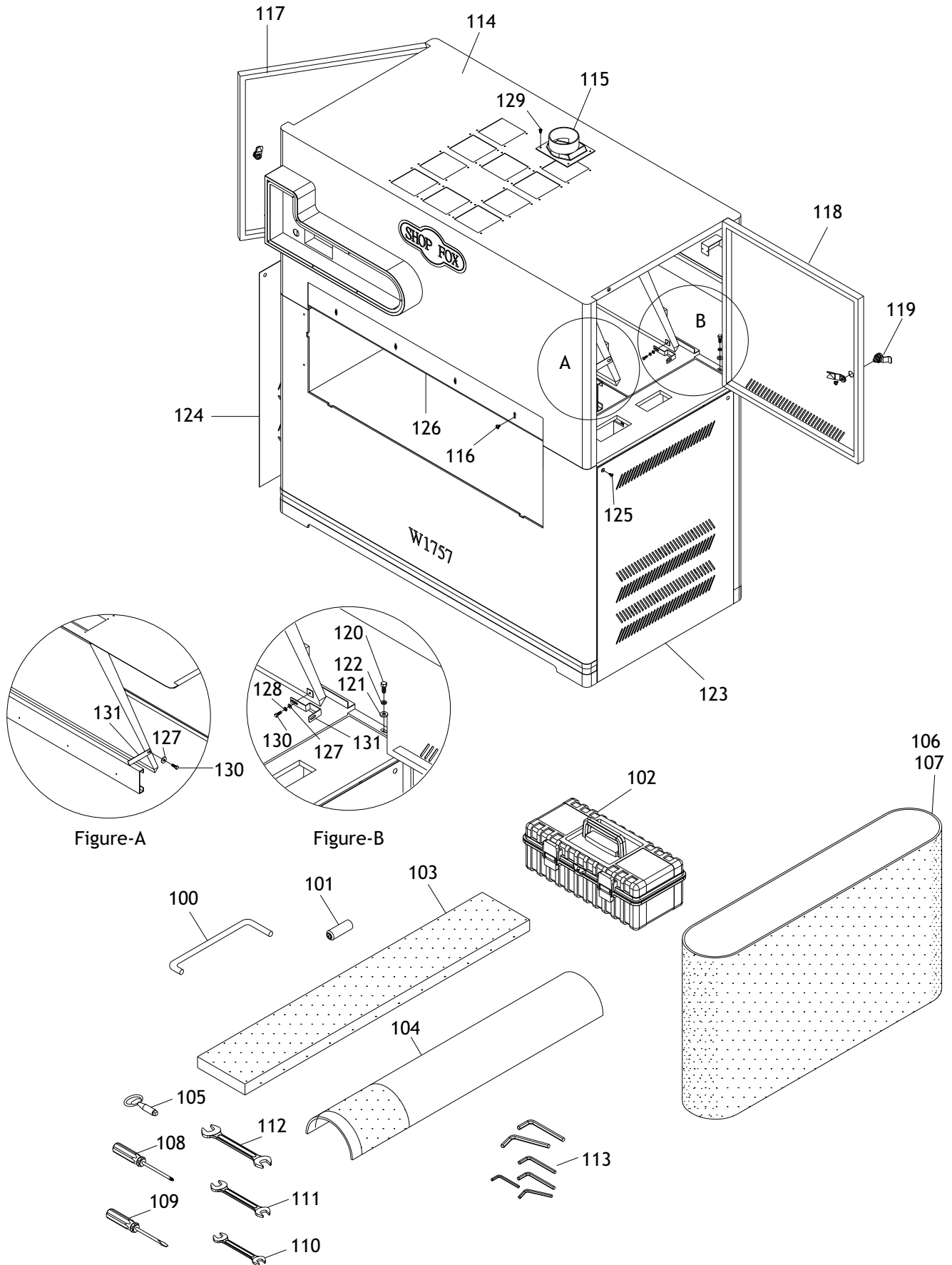

Figure-A

Figure-B

Tools & Cabinet Parts List

REF	PART #	DESCRIPTION
100	X1756100	PLATEN REMOVAL TOOL
101	X1756101	CERAMIC LIMIT SWITCH TUBE
102	X1756102	TOOL BOX
103	X1756103	FELT PLATEN PAD 25"
104	X1756104	GRAPHITE PAD 25" X 3.54"
105	X1756105	DOOR KEY
106	X1756106	SANDPAPER: #100 (43" X 60")
107	X1756107	SANDPAPER: #180 (43" X 60")
108	X1756108	PHILLIPS SCREWDRIVER #2
109	X1756109	STANDARD SCREWDRIVER #2
110	XPWR810	WRENCH 8 X 10
111	XPWR1214	WRENCH 12 X 14
112	XPWR1719	WRENCH 17 X 19
113	X1756113	HEX WRENCH SET
114	X1756114	UPPER FRAME COVER (W1756)
114	X1757114	UPPER FRAME COVER (W1757)
115	X1756115	DUST PORT 4"
116	XPS14M	PHLP HD SCR M6-1 X 12
117	X1756117	LEFT ACCESS PANEL (W1756)

REF	PART #	DESCRIPTION
117	X1757117	LEFT ACCESS PANEL (W1757)
118	X1756118	RIGHT ACCESS PANEL (W1756)
118	X1757118	RIGHT ACCESS PANEL (W1757)
119	X1756119	DOOR LOCK
120	XPB07	HEX BOLT 5/16-18 X 3/4
121	XPW07	FLAT WASHER 5/16
122	XPLW01	LOCK WASHER 5/16
123	X1756123	RIGHT DOOR, LOWER FRAME (W1756)
123	X1757123	RIGHT DOOR, LOWER FRAME (W1757)
124	X1756124	LEFT DOOR, LOWER FRAME (W1756)
124	X1757124	LEFT DOOR, LOWER FRAME (W1757)
125	XPFH03	FLAT HD SCR 1/4-20 X 1/2
126	X1756126	FRONT PROTECTION PLATE (W1756)
126	X1757126	FRONT PROTECTION PLATE (W1757)
127	XPW06	FLAT WASHER 1/4
128	XPLW02	LOCK WASHER 1/4
129	XPS14M	PHLP HD SCR M6-1 X 12
130	XPB83M	HEX BOLT M6-1 X 16
131	X1756131	STANDOFF BRACKET

Sanding Motor & Frame (W1756)

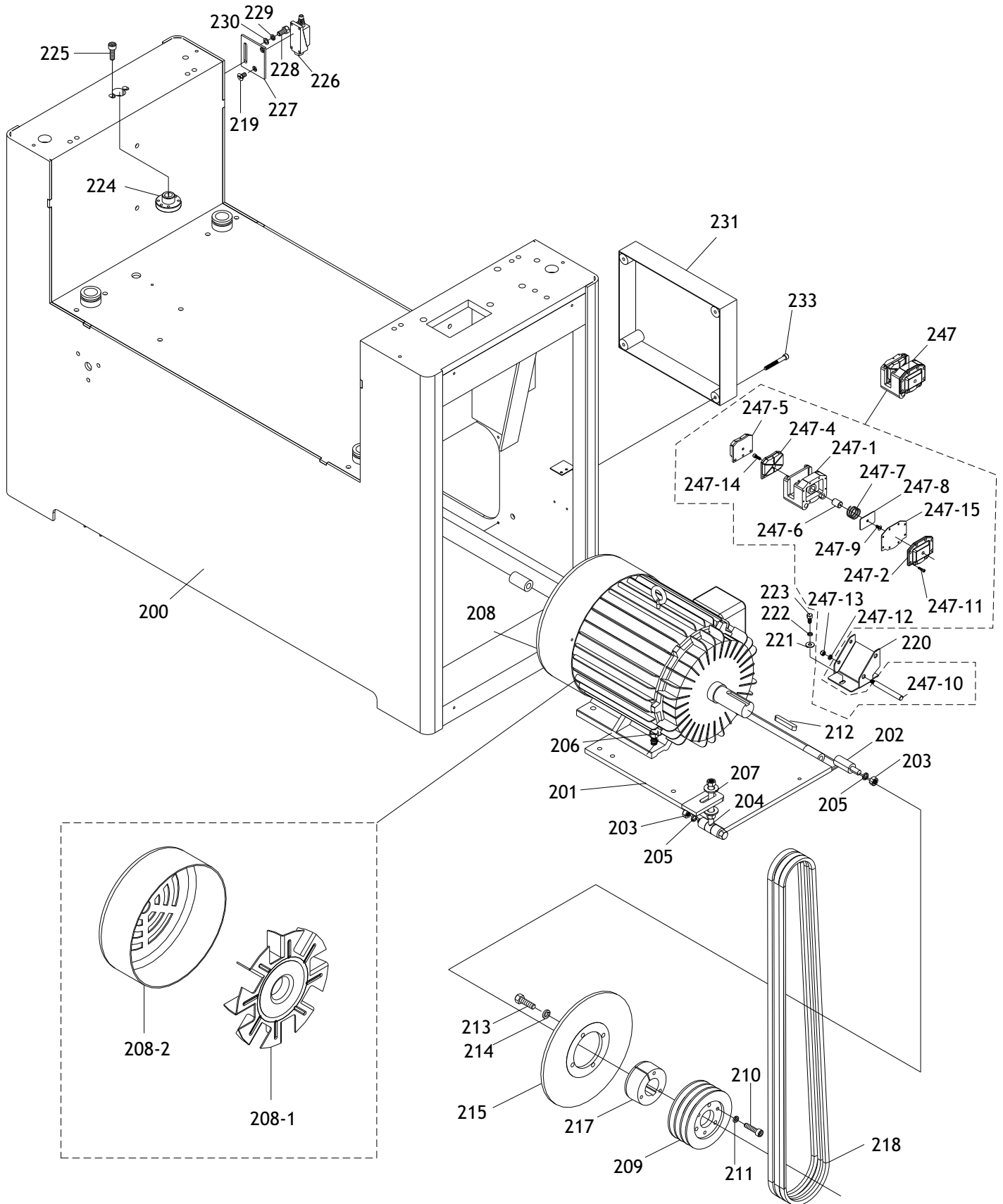

Sanding Motor & Frame Parts List

REF	PART #	DESCRIPTION
200	X1756200	MACHINE FRAME (W1756)
200	X1757200	MACHINE FRAME (W1757)
201	X1756201	MOTOR BASE (W1756)
201	X1757201	MOTOR BASE (W1757)
202	X1756202	MOTOR BASE HINGE (W1756)
202	X1757202	MOTOR BASE HINGE (W1757)
203	XPNO6	HEX NUT 1/2-12
204	X1756204	MOTOR BASE ADJ. ROD (W1756)
204	X1757204	MOTOR BASE ADJ. ROD (W1757)
205	XPLW07	LOCK WASHER 1/2
206	XPB41	HEX BOLT 1/2-12 X 1-1/2
207	XPW01	FLAT WASHER 1/2
208	X1756208	MOTOR 25HP 220V/440V 3PH
208-1	X1756208-1	MOTOR FAN
208-2	X1756208-2	MOTOR FAN COVER
209	X1756209	PULLEY
210	XPSB11	CAP SCREW 5/16-18 X 1-1/4
211	XPLW01	LOCK WASHER 5/16
212	X1756212	KEY 14 X 9 X 105 (W1756)
212	X1757212	KEY 14 X 10 X 105 (W1757)
213	XPB03	HEX BOLT 5/16-18 X 1
214	XPLW01	LOCK WASHER 5/16
215	X1756215	ROTOR
216	XPVB76	V-BELT B-76 5L760 (W1757)
217	X1756217	PULLEY BUSHING
218	XPVB68	V-BELT B-68 5L680 (W1756)
218	XPVA50	V-BELT A-50 4L500 (W1757)
219	XPFH30M	FLAT HD SCR M5-.8 X 8 (W1756)
220	X1756220	BRAKE BRACKET
221	XPW02	FLAT WASHER 3/8
222	XPLW04	LOCK WASHER 3/8
223	XPB21	HEX BOLT 3/8-16 X 3/4
224	X1756224	THREADED HUB 5/8 X 11
225	XPSB05	CAP SCREW 1/4-20 X 3/4
226	X1756226	LIMIT SWITCH ME8111

REF	PART #	DESCRIPTION
227	X1756227	LIMIT SWITCH PLATE
228	XPB02	HEX BOLT 1/4-20 X 5/8
229	XPLW02	LOCK WASHER 1/4 (W1756)
230	XPW06	FLAT WASHER 1/4
231	X1756231	BACK COVER (W1756)
232	XPFH30M	FLAT HD SCR M5-.8 X 8 (W1757)
233	XPB19	HEX BOLT 1/4-20 X 1/2 (W1756)
234	XPLW02	LOCK WASHER 1/4 (W1757)
235	X1757235	IDLE WHEEL ADJ BRACKET (W1757)
236	XPLW10	LOCK WASHER 3/4 (W1757)
237	XPNO17	HEX NUT 3/4-10 (W1757)
238	XPW13	FLAT WASHER 3/4 (W1757)
239	XPB84	HEX BOLT 3/8-16 X 3-1/2 (W1757)
240	XPNO8	HEX NUT 3/8-16 (W1757)
241	X1757241	IDLE WHEEL SHAFT (W1757)
242	XP6305	BALL BEARING 6305ZZ (W1757)
243	X1757243	PULLEY (W1757)
244	XP6206	BALL BEARING 6206ZZ (W1757)
245	XPR11M	EXT RETAINING RING 25MM (W1757)
246	XPVA40	V-BELT A-40 4L400 (W1757)
247	X1756247	BRAKE ASSEMBLY
247-1	X1756247-1	BRAKE BRACKET
247-2	X1756247-2	BRAKE BRACKET FRONT GUARD
247-4	X1756247-4	BRAKE LINING SET
247-5	X1756247-5	BRAKE LINING SET
247-6	X1756247-6	BRAKE ARBOR
247-7	X1756247-7	BRAKE COMPRESSION SPRING
247-8	X1756247-8	BRAKE INSIDE PIECE
247-9	XPFH04	FLAT HD SCR 1/4-20 X 5/8
247-10	X1756247-10	BRAKE PIN
247-11	XPSB31	CAP SCREW 10-24 X 5/8
247-12	XPLW04	LOCK WASHER 3/8
247-13	XPNO8	HEX NUT 3/8-16
247-14	XPSB04	CAP SCREW 1/4-20 X 1/2
247-15	X1756247-15	BRAKE GASKET

Table Lift

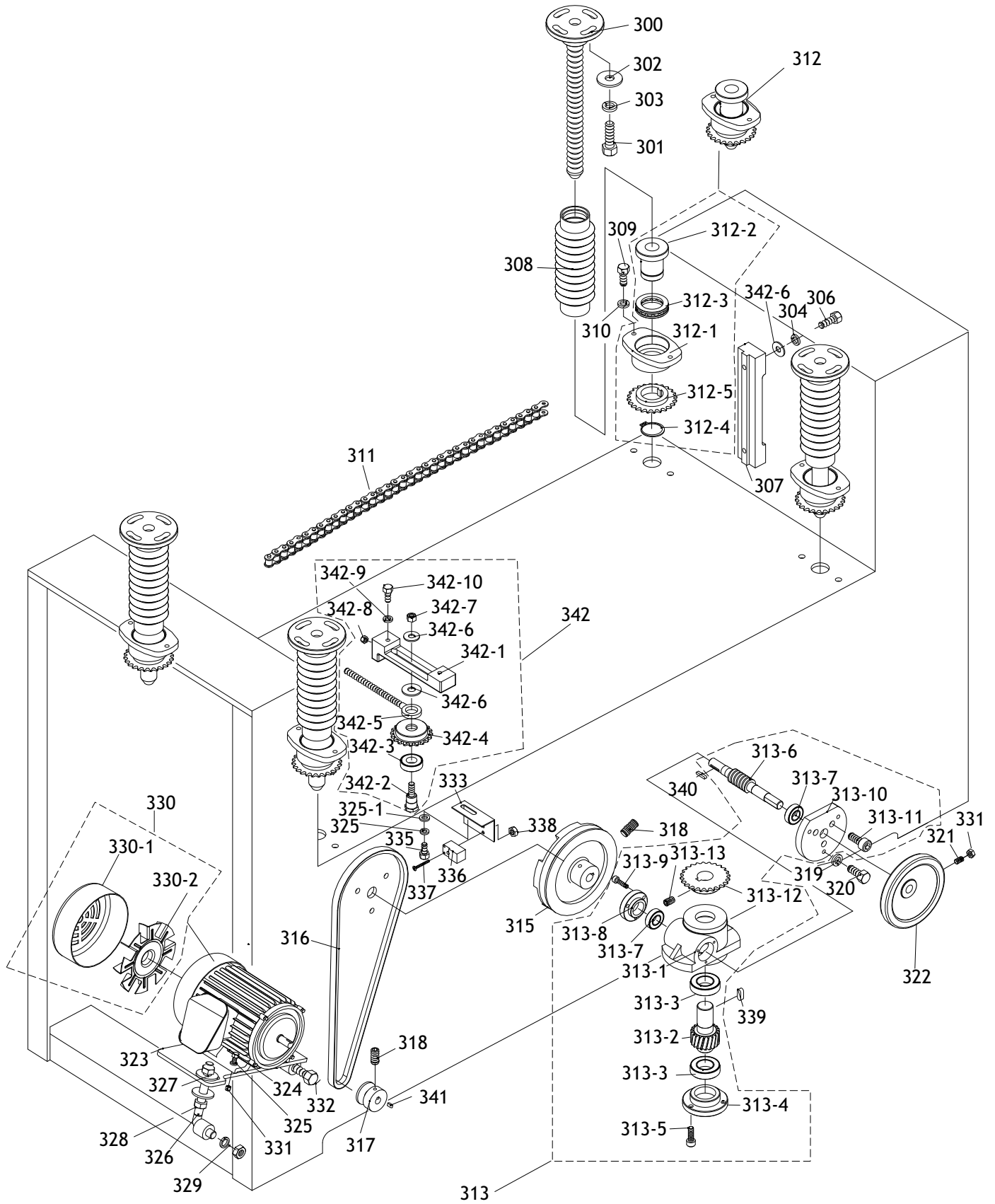

Table Lift Parts List

REF	PART #	DESCRIPTION
300	X1756300	ELEVATION SCREW
301	XPB03	HEX BOLT 5/16-18 X 1
302	XPW07	FLAT WASHER 5/16
303	XPLW01	LOCK WASHER 5/16
304	XPLW04	LOCK WASHER 3/8
306	XPB18	HEX BOLT 3/8-16 X 1
307	X1756307	ELEVATION SLIDE
308	X1756308	DUST BOOT
309	XPB07	HEX BOLT 5/16-18 X 3/4
310	XPLW01	LOCK WASHER 5/16
311	X1756311	CHAIN 3/8" (W1756)
311	X1757311	CHAIN 1/2" (W1757)
312	X1756312	NUT HOUSING ASSEMBLY
312-1	X1756312-1	NUT HOUSING
312-2	X1756312-2	NUT
312-3	X1756312-3	THRUST BEARING 51107
312-4	XPR12M	EXT RETAINING RING 35MM
312-5	X1756312-5	SPROCKET WHEEL
313	X1756313	ELEVATION GEAR BOX ASSEMBLY
313-1	X1756313-1	ELEVATION GEAR BOX
313-2	X1756313-2	WORM GEAR
313-3	XP6005	BALL BEARING 6005ZZ
313-4	X1756313-4	BEARING CAP
313-5	XPSB05	CAP SCREW 1/4-20 X 3/4
313-6	X1756313-6	WORM SHAFT
313-7	XP6002ZZ	BALL BEARING 6002ZZ
313-8	X1756313-8	BEARING CAP
313-9	XPSB31	CAP SCREW 10-24 X 5/8
313-10	X1756313-10	BEARING CAP
313-11	XPSB01	CAP SCREW 1/4-20 X 5/8
313-12	X1756313-12	SPROCKET WHEEL
313-13	XPSS07	SET SCREW 1/4-20 X 1/2 (W1756)
313-13	XPSS08	SET SCREW 5/16-18 X 1/2 (W1757)
315	X1756315	PULLEY
316	XPVA34	V-BELT A-34 4L340 (W1756)
316	XPVA36	V-BELT A-36 4L360 (W1757)
317	X1756317	PULLEY (W1756)
317	X1757317	PULLEY (W1757)

REF	PART #	DESCRIPTION
318	XPSS07	SET SCREW 1/4-20 X 1/2
319	XPLW01	LOCK WASHER 5/16
320	XPB07	HEX BOLT 5/16-18 X 3/4
321	XPSS07	SET SCREW 1/4-20 X 1/2
322	X1756322	HANDWHEEL
323	X1756323	MOTOR BASE
324	XPB31	HEX BOLT 1/4-20 X 1
325	XPLW02	LOCK WASHER 1/4
325-1	XPW06	FLAT WASHER 1/4
326	X1756326	MOTOR BASE ADJUSTMENT ROD
327	XPW01	FLAT WASHER 1/2
328	XPN06	HEX NUT 1/2-12
329	XPLW07	LOCK WASHER 1/2
330	X1756330	MOTOR 1/4HP 220V/440V 3PH
330-1	X1756330-1	FAN COVER
330-2	X1756330-2	FAN
331	XPN05	HEX NUT 1/4-20
332	XPB89	HEX BOLT 1/2-12 X 4-1/2
333	X1756333	PROXIMITY SWITCH PLATE
335	X1756335	SPECIAL SCREW 1/4-20 X 3/4 (W1756)
335	XPB19	HEX BOLT 1/4-20 X 1/2 (W1757)
336	X1756336	PROXIMITY SWITCH
337	X1756337	SPECIAL SCREW M3-.5 X 30
338	XPN07M	HEX NUT M3-.5
339	XPB14	KEY 5/16 X 5/16 X 3/4
340	XPB48M	KEY 4 X 4 X 20
341	XPB37M	KEY 4 X 4 X 16
342	X1756342	SPROCKET WHEEL SET
342-1	X1756342-1	SPROCKET WHEEL ADJUSTOR
342-2	X1756342-2	SPROCKET WHEEL SHAFT
342-3	XP6003	BALL BEARING 6003ZZ
342-4	X1756342-4	ADJUSTMENT SPROCKET
342-5	X1756342-5	ADJUSTMENT ROD
342-6	XPW02	FLAT WASHER 3/8
342-7	XPB08	HEX NUT 3/8-16
342-8	XPB02	HEX NUT 5/16-18
342-9	XPLW01	LOCK WASHER 5/16
342-10	XPB07	HEX BOLT 5/16-18 X 3/4

Feed & Conveyor Parts List

REF	PART #	DESCRIPTION
400	X1756400	CONVEYOR TABLE
401	X1756401	CONVEYOR BELT
402	X1756402	GEARBOX REDUCER FIXED PLATE
403	X1756403	CUSHION
404	XPW02	FLAT WASHER 3/8
405	XPB32M	HEX BOLT M10-1.5 X 25
406	X1756406	OUTFEED ROLLER
407	X1756407	BEARING UCF206
408	X1756408	GEARBOX REDUCER
409	X1756409	BREATHER PLUG
410	X1756410	PLUG
411	XPUCF205	BALL BEARING UCF205
412	XPLW04	LOCK WASHER 3/8
413	XPB24	HEX BOLT 3/8-16 X 1-1/4
414	X1756414	BEARING CAP
415	X1756415	DRIVE PULLEY 2HP (W1756)
415	X1757415	DRIVE PULLEY 1HP (W1757)
416	XPB16	HEX BOLT 3/8-16 X 1-1/2
417	X1756417	DRIVING PULLEY 2HP (W1756)
417	X1757417	DRIVING PULLEY 1HP (W1757)
418	XPB151M	KEY 8 X 8 X 55
419	XPB07M	HEX BOLT M8-1.25 X 25
420	XPLW04M	LOCK WASHER 8MM
421	X1756421	MOTOR 2HP 220V / 440V 3PH
421-1	X1756421-1	MOTOR FAN COVER
421-2	X1756421-2	MOTOR FAN

REF	PART #	DESCRIPTION
422	XPLW06M	LOCK WASHER 10MM
423	X1756423	TIMING BELT 1422V-290
424	XPSB64M	CAP SCREW M10-1.5 X 25
425	X1756425	BASE PLATE
426	X1756426	VARIABLE SPEED UNIT COVER
427	XPSS21M	SET SCREW M8-1.25 X 25 (W1756)
427	XPB09M	HEX BOLT M8-1.25 X 20 (W1757)
428	X1756428	INFEED ROLLER BRACKET
429	XPSB16	CAP SCREW 3/8-16 X 3/4
430	X1756430	INFEED ROLLER BRACKET
431	X1756431	CONVEYOR BELT POSITION WHEEL
432	XPSB70	CAP SCREW 5/16-18 X 2
433	XPLW01	LOCK WASHER 5/16
434	XPN02	HEX NUT 5/16-18
435	X1756435	EMGNCY BRAKE PUSH-PLATE
436	XPS04	PHLP HD SCR 1/4-20 X 1/2
437	X1756437	LIMIT SWITCH
438	X1756438	PHLP HD SCR 10-24 X 1-1/2
439	XPLW06M	LOCK WASHER 10MM
440	XPB95	HEX BOLT 1/2-12 X 3
441	X1756441	INFEED ROLLER SHAFT
442	X1756442	INFEED ROLLER
443	XP6206	BALL BEARING 6206ZZ
444	XPR15M	EXT RETAINING RING 30MM
445	X1756445	ELEVATION SWITCH
446	XPSB62	CAP SCREW 1/4-20 X 1-1/2

Upper Roller

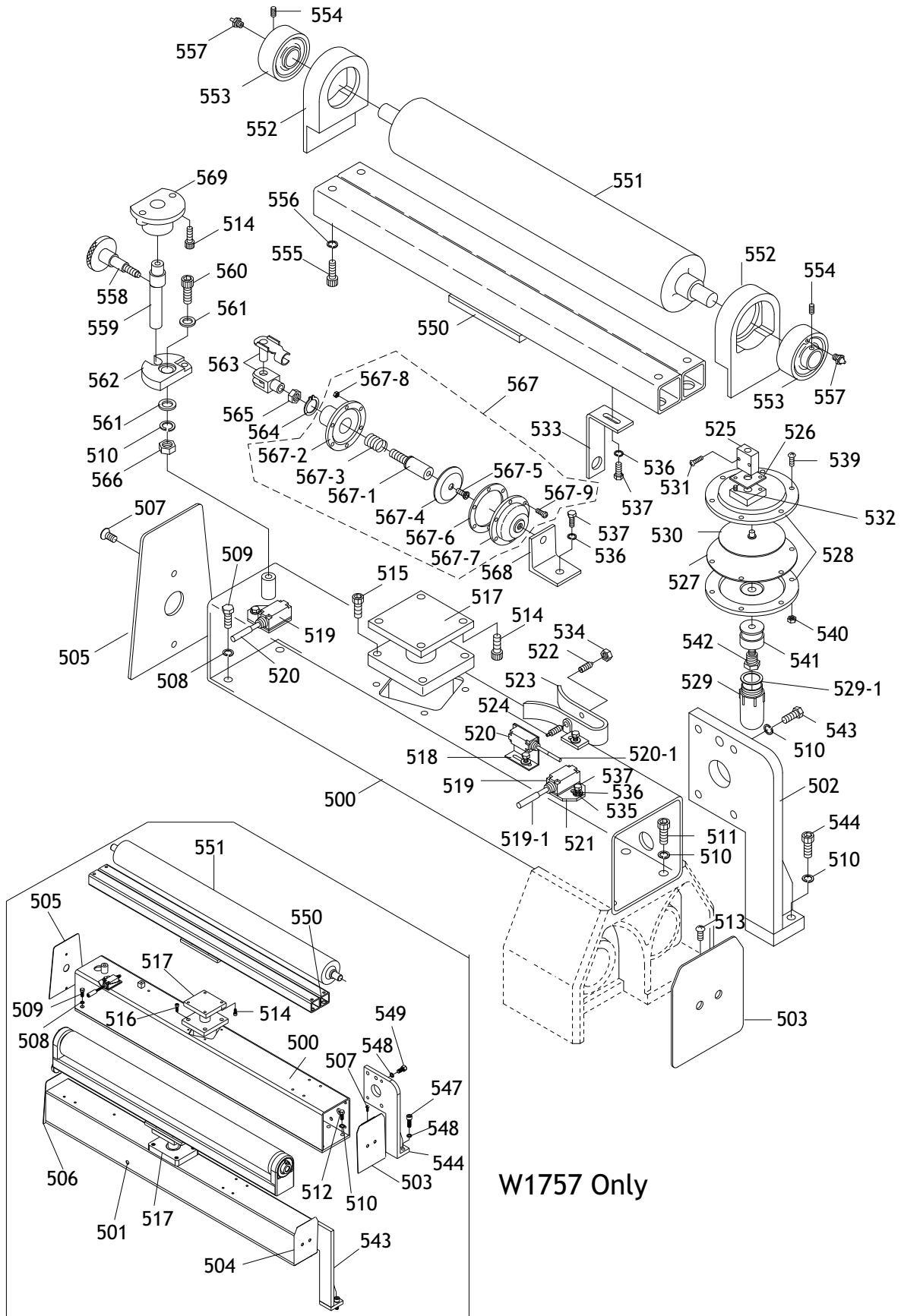

W1757 Only

Upper Roller Parts List

REF	PART #	DESCRIPTION
500	X1756500	SQUARE FRAME (W1756)
500	X1757500	SQUARE FRAME- REAR (W1757)
501	X1756501	SQUARE FRAME- FRONT (W1757)
502	X1756502	SUPPORTING FRAME (W1756)
503	X1756503	SQUARE FRAME SEAL (R) (W1756)
503	X1757503	SQUARE FRAME SEAL (R) (W1757)
504	X1757504	SQUARE FRAME SEAL (FR R) (W1757)
505	X1756505	SQUARE FRAME SEAL (L) (W1756)
505	X1757505	SQUARE FRAME SEAL (L) (W1757)
506	X1757506	SQUARE FRAME SEAL (FR L) (W1757)
507	XPFH03	FLAT HD SCR 1/4-20 X 1/2
508	XPLW04	LOCK WASHER 3/8
509	XPB18	HEX BOLT 3/8-16 X 1
510	XPLW07	LOCK WASHER 1/2
511	XPSB76	CAP SCREW 1/2-12 X 1-1/2 (W1756)
512	XPB53	HEX BOLT 1/2-12 X 1 (W1757)
513	XPS04	PHLP HD SCR 1/4-20 X 1/2
514	XPSB07	CAP SCREW 5/16-18 X 3/4
515	XPSB03	CAP SCREW 5/16-18 X 1 (W1756)
516	XPB03	HEX BOLT 5/16-18 X 1 (W1757)
517	X1756517	AIR CYLINDER (W1756)
517	X1757517	AIR CYLINDER (W1757)
518	X1756518	LIMIT SWITCH HOLDER (L TYPE)
519	X1756519	LIMIT SWITCH WITH CERAMIC TIP
519-1	X1756519-1	CERAMIC TIP
520	X1756520	LIMIT SWITCH W/PLASTIC TIP
520-1	X1756520-1	PLASTIC TIP
521	X1756521	LIMIT SWITCH HOLDER
522	X1756522	AIR SENSOR NOZZLE (FEMALE)
523	X1756523	AIR FORK
524	X1756524	AIR SENSOR NOZZLE (MALE)
525	X1756525	THROTTLE VALVE
526	X1756526	THROTTLE VALVE BASE
527	X1756527	PLATE
528	X1756528	HOUSING ASSEMBLY
529	X1756529	OIL CUP
529-1	X1756529-1	OIL CUP GASKET
530	X1756530	ALUMINUM PLATE
531	XPS52M	PHLP HD SCR M4-.7 X 20
532	XPS02M	PHLP HD SCR M4-.7 X 12
533	X1756533	SHUTDOWN BRACKET
534	XPN11	HEX NUT 3/8-24
535	XPW07	FLAT WASHER 5/16

REF	PART #	DESCRIPTION
536	XPLW01	LOCK WASHER 5/16
537	XPB09	HEX BOLT 5/16-18 X 1/2
539	XPSB33	CAP SCREW 10-24 X 3/4
540	XPN07	HEX NUT 10-24
541	X1756541	OIL CAP CONNECTOR
542	X1756542	SHAFT OF OIL CAP
543	XPB53	HEX BOLT 1/2-12 X 1 (W1756)
543	X1757543	BRACKET (W1757)
544	XPSB76	CAP SCREW 1/2-12 X 1-1/2 (W1756)
544	X1757544	BRACKET (W1757)
547	XPSB76	CAP SCREW 1/2-12 X 1-1/2 (W1757)
548	XPLW07	LOCK WASHER 1/2 (W1757)
549	XPB53	HEX BOLT 1/2-12 X 1 (W1757)
550	X1756550	UPPER ROLLER BRACKET
551	X1756551	UPPER ROLLER
552	X1756552	UPPER ROLLER BRACKET
553	X1756553	BEARING UCC205
554	XPSS02M	SET SCREW M6-1 X 6
555	XPSB16	CAP SCREW 3/8-16 X 3/4
556	XPLW04	LOCK WASHER 3/8
557	X1756557	GREASE FITTING W/DUST CAP
558	XPSW03-1	KNOB
559	X1756559	ECCENTRIC ROD
560	XPSB99	CAP SCREW 1/2-12 X 3-1/4
561	XPW01	FLAT WASHER 1/2
562	X1756562	ECCENTRIC
563	X1756563	CLEVIS ASSEMBLY
564	XPR05M	EXT RETAINING RING 15MM
565	X1756565	HEX NUT M10-1.5(LH)
566	XPN06	HEX NUT 1/2-12
567	X1756567	AIR CYLINDER DIAPHRAGM ASSY
567-1	X1756567-1	SHAFT OF AIR CYLINDER
567-2	X1756567-2	BOTTOM COVER
567-3	X1756567-3	COMPRESSION SPRING
567-4	X1756567-4	ALUMINUM PLATE
567-5	XPFH02M	FLAT HD SCR M6-1 X 12
567-6	X1756567-6	PLATE
567-7	X1756567-7	TOP COVER
567-8	XPN07	HEX NUT 10-24
567-9	XPSB33	CAP SCREW 10-24 X 3/4 (W1756)
567-9	XPS08	PHLP HD SCR 10-24 X 3/4 (W1757)
568	X1756568	AIR CYLINDER BASE
569	X1756569	ECCENTRIC SHAFT FRAME

Belt Oscillation (W1756)

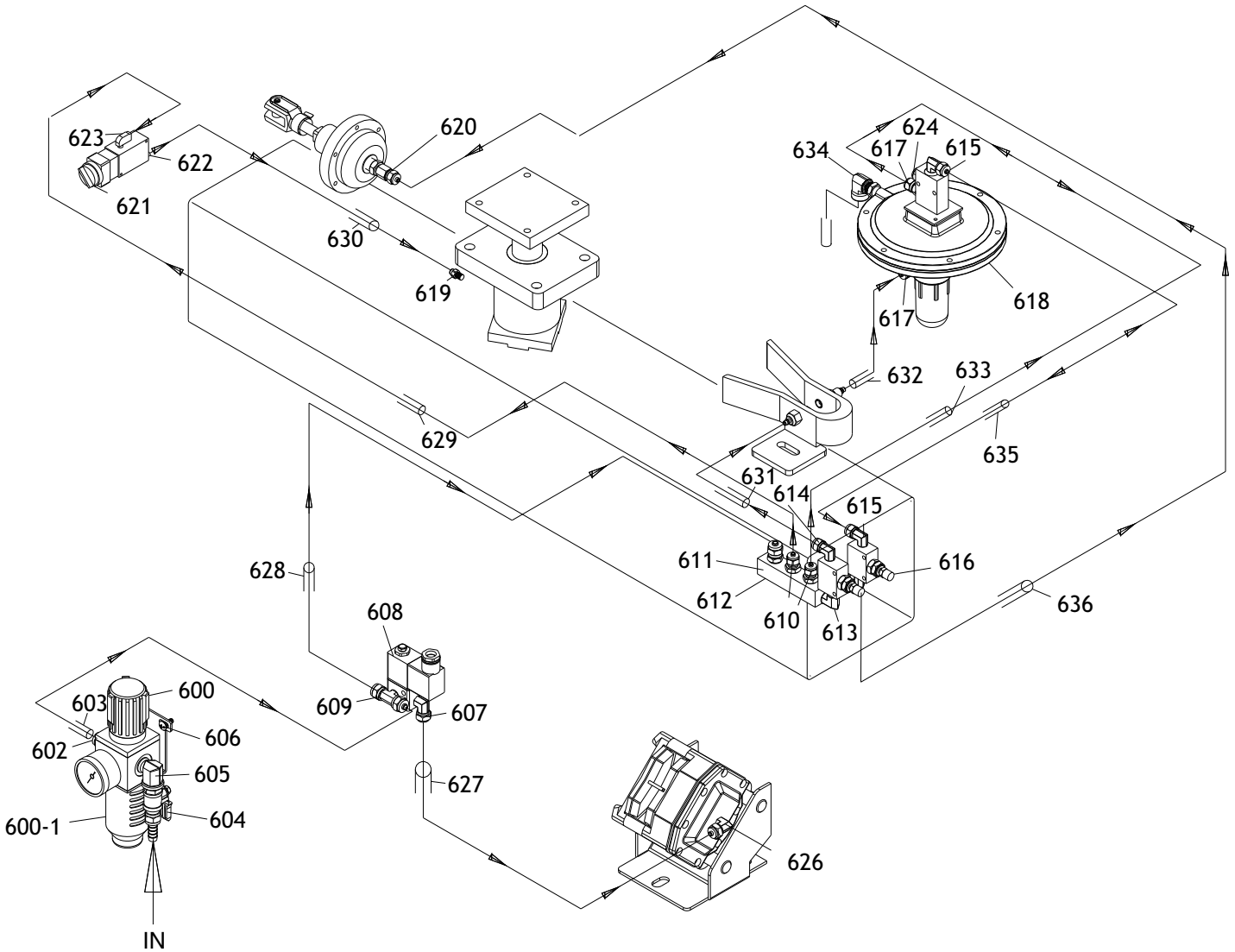

Belt Oscillation (W1757)

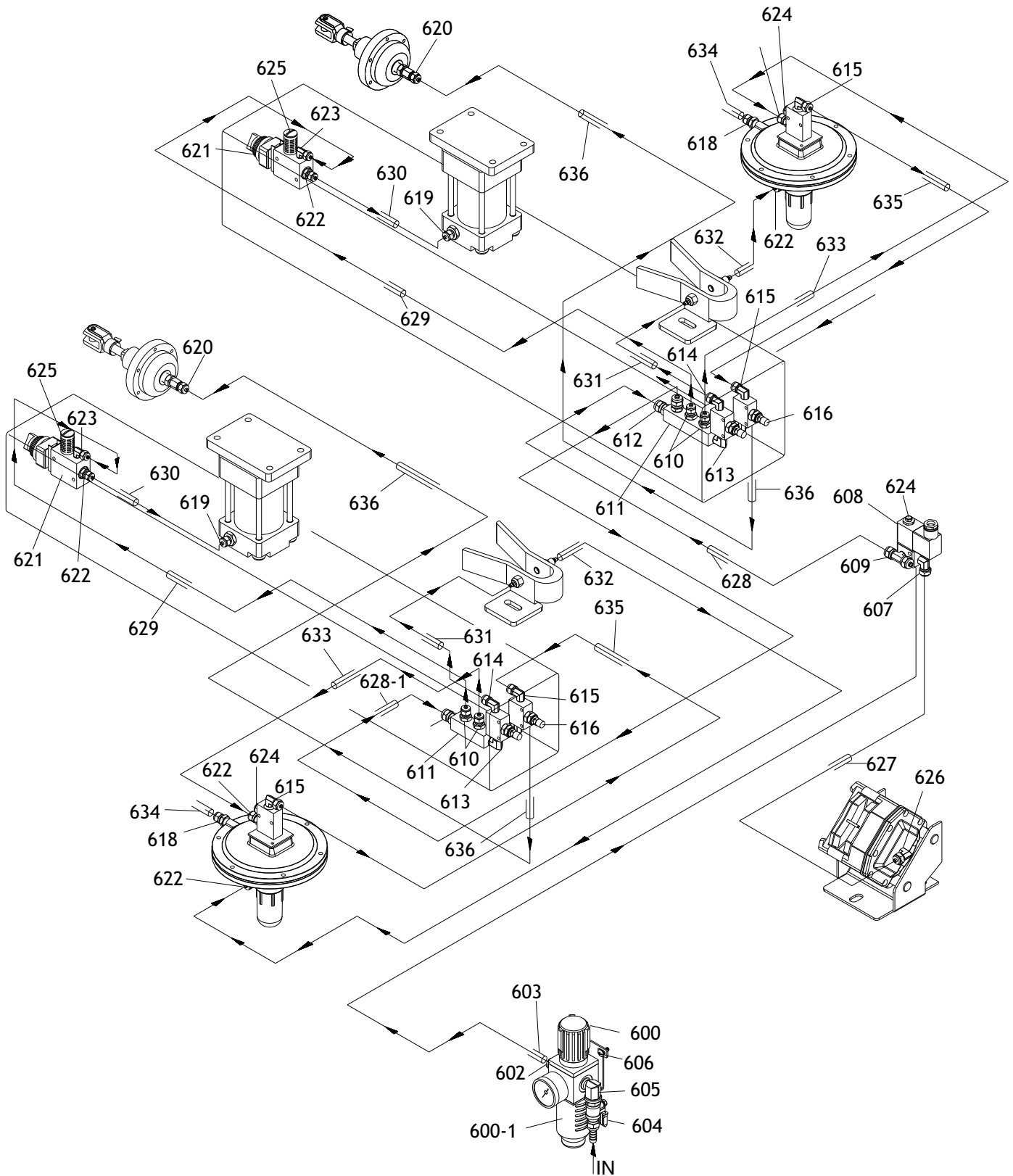

Belt Oscillation Parts List

REF	PART #	DESCRIPTION
600	X1756600	PRESSURE REGULATOR
600-1	X1756600-1	FILTER CUP
602	X1756602	BRONZE CONNECTOR 5/16N X 1/4T
603	X1756603	FLEXIBLE HOSE 8X900MM
604	X1756604	AIR SWITCH 1/4"
605	X1756605	ELBOW 1/4T X 1/4N 90° (W1756)
605	X1757605	ELBOW 1/4T X 1/4N 90° (W1757)
606	X1756606	PHLP HD SCR 10-24 X 5/8
607	X1756607	ELBOW 5/16N X 1/8T 90_
608	X1756608	SOLENOID VALVE
609	X1756609	T-FITTING 5/16N X 5/16N X 1/8T
610	X1756610	CONNECTOR 1/4N X 1/4T
611	X1756611	MANIFOLD 1/4N
612	X1756612	CONNECTOR 5/16N X 1/4T
613	X1756613	ELBOW 1/4N X 1/8T 90° (W1756)
613	X1757613	ELBOW 1/4T X 1/4T X 90° (W1757)
614	X1756614	CONNECTOR 5/16N X 1/8T 90° (W1756)
614	X1757614	CONNECTOR 1/4N X 1/8T 90° (W1757)
615	X1756615	CONNECTOR 5/16N X 1/8T 90° (W1756)
615	X1757615	CONNECTOR 1/4N X 1/8T 90° (W1757)
616	X1756616	THROTTLE VALVE 1/8"
617	X1756617	CONNECTOR 1/4N X 1/8T (W1756)
618	X1756618	CONNECTOR 1/4N X 1/4N -28U 90°
619	X1756619	CONNECTOR 1/4N X 3/8T

REF	PART #	DESCRIPTION
620	X1756620	CONNECTOR 1/4N X 1/8T
621	X1756621	AIR SWITCH 1/8"
622	X1756622	CONNECTOR 1/4N X 1/8T
623	X1756623	CONNECTOR 1/4N X 1/8T 90°
624	X1756624	BUFFER 1/8"
625	X1757625	BUFFER (PLASTIC) 1/8" (W1757)
626	X1756626	CONNECTOR 5/16N X 1/8T 90°
627	X1756627	FLEXIBLE HOSE 8 X 700MM (W1756)
627	X1757627	FLEXIBLE HOSE 8 X 900MM (W1757)
628	X1756628	FLEXIBLE HOSE 8 X 1400MM
628-1	X1757628-1	FLEXIBLE HOSE 6 X 1400MM (W1757)
629	X1756629	FLEXIBLE HOSE 6 X 1600/1800MM (W1756)
629	X1757629	FLEXIBLE HOSE 6 X 1100/1420MM (W1757)
630	X1756630	FLEXIBLE HOSE 6 X 750/950MM (W1756)
630	X1757630	FLEXIBLE HOSE 6 X 500/620MM (W1757)
631	X1756631	FLEXIBLE HOSE 6 X 600MM (W1756)
631	X1757631	FLEXIBLE HOSE 6 X 560MM (W1757)
632	X1756632	FLEXIBLE HOSE 6 X 250MM (W1756)
632	X1757632	FLEXIBLE HOSE 6 X 650MM (W1757)
633	X1756633	FLEXIBLE HOSE 6 X 650MM
634	X1756634	FLEXIBLE HOSE 6 X 300MM
635	X1756635	FLEXIBLE HOSE 6 X 650MM
636	X1756636	FLEXIBLE HOSE 6 X 1500/1700MM (W1756)
636	X1757636	FLEXIBLE HOSE 6 X 860/1350MM (W1757)

Sanding Drum & Pressure Roller (W1756)

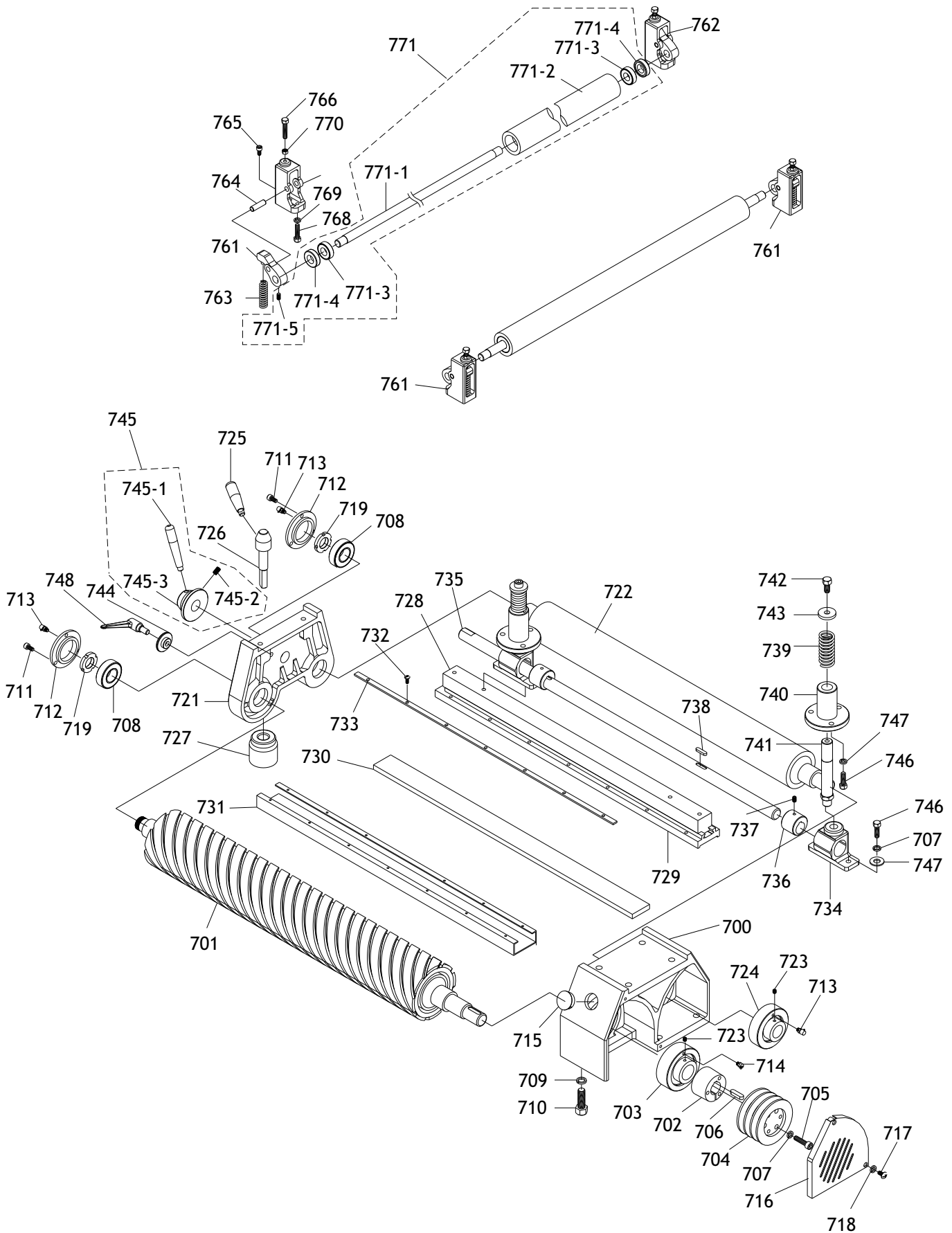

Sanding Drum & Pressure Roller (W1757)

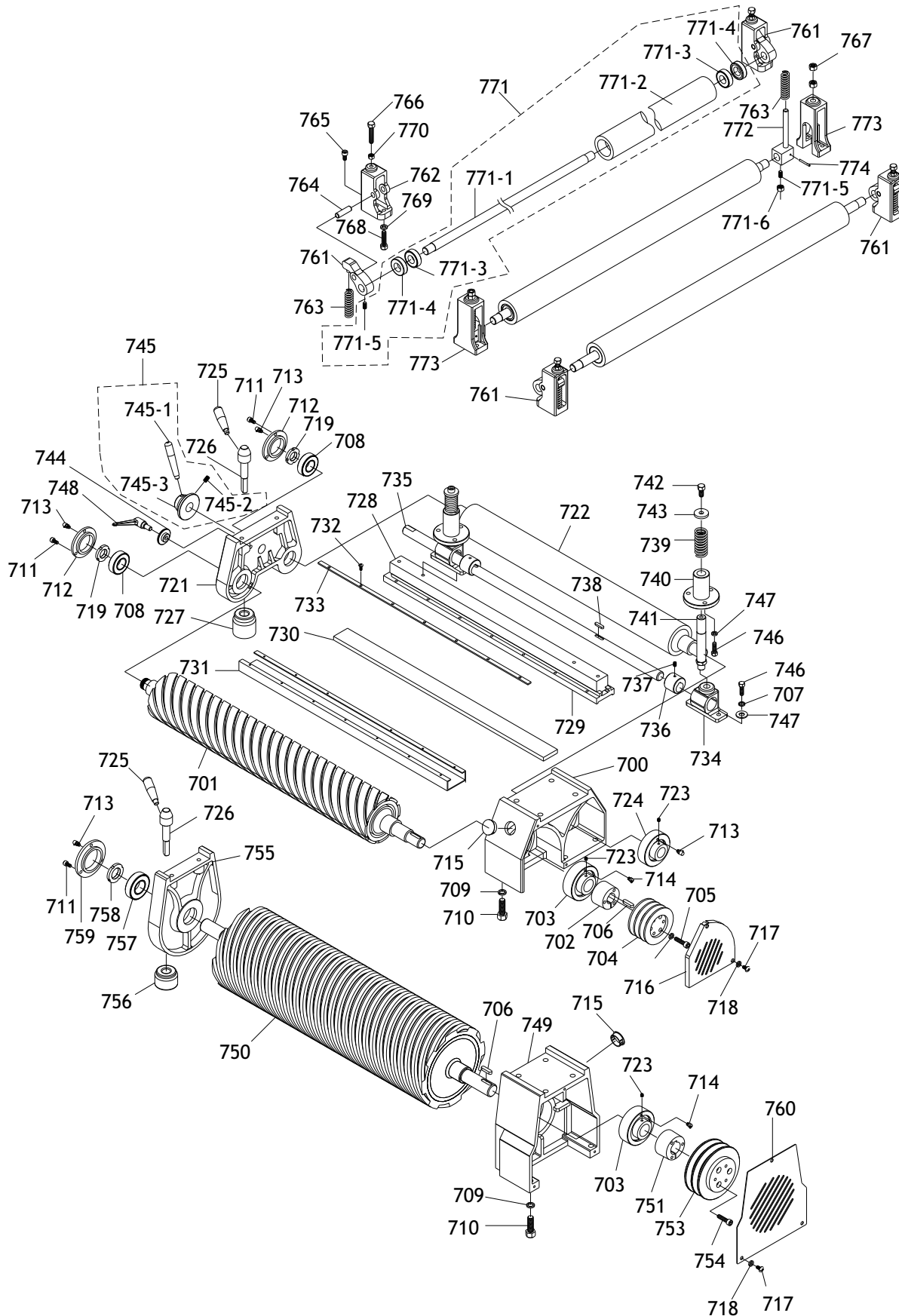

Sanding Drum & Pressure Roller Parts List

REF	PART #	DESCRIPTION
700	X1756700	BEARING HOUSING (W1756)
700	X1757700	BEARING HOUSING (W1757)
701	X1756701	RUBBER ROLLER (W1756)
701	X1757701	RUBBER ROLLER (W1757)
702	X1756702	FASTENING TUBE (W1756)
702	X1757702	FASTENING TUBE (W1757)
703	X1756703	BEARING UCC206
704	X1756704	PULLEY
705	XPSB11	CAP SCREW 5/16-18 X 1-1/4
706	XPK136M	KEY 8 X 8 X 30
707	XPLW01	LOCK WASHER 5/16
708	XP62052RS	BALL BEARING 6205-2RS
709	XPLW07	LOCK WASHER 1/2
710	XPB41	HEX BOLT 1/2-12 X 1-1/2
711	XPSB04	CAP SCREW 1/4-20 X 1/2
712	X1756712	BEARING CAP (W1756)
712	X1757712	BEARING CAP (W1757)
713	X1756713	GREASE FITTING W/CAP
714	X1756714	GREASE FITTING W/CAP
715	X1756715	PLUG
716	X1756716	PULLEY COVER (W1756)
716	X1757716	PULLEY COVER (W1757)
717	XPS02	PHLP HD SCR 1/4-20 X 3/4 (W1756)
717	X1757717	PHLP HD SCR 1/4-20 X 3/8 (W1757)
718	XPLW02	LOCK WASHER 1/4
719	X1756719	SPANNER NUT
721	X1756721	BEARING HOUSING
722	X1756722	STEEL ROLLER
723	XPSS02M	SET SCREW M6-1 X 6 (W1756)
723	X1757723	SPCL SET SCREW M6-.5 X 6 (W1757)
724	X1756724	BEARING UCC205
725	X1756725	HANDLE
726	X1756726	LOCK POST RELEASE LEVER (W1756)
726	X1757726	LOCK POST RELEASE LEVER (W1757)
727	X1756727	BEARING BRACKET PAD
728	X1756728	44" GRAPHITE BRACKET MALE
729	X1756729	44" GRAPHITE BRACKET FEMALE
730	X1756730	44" FELT PLATEN PAD
731	X1756731	GRAPHITE PAD 44" X 3.54"
732	XPS01	PHLP HD SCR 10-24 X 1/2
733	X1756733	44" GRAPHITE PRESSURE PLATE
734	X1756734	GRAPHITE BRACKET BASE
735	X1756735	GRAPHITE BRACKET SHAFT
736	X1756736	LOCK COLLAR
737	XPSS03	SET SCREW 1/4-20 X 3/8
738	XPK143M	KEY 6 X 6 X 25
739	X1756739	COMPRESSION SPRING
740	X1756740	HOUSING
741	X1756741	GRAPHITE BRACKET SHAFT

REF	PART #	DESCRIPTION
742	XPSB16	CAP SCREW 3/8-16 X 3/4
743	XPW02	FLAT WASHER 3/8
744	XPW02	FLAT WASHER 3/8
745	X1756745	GRAPHITE BRACKET ADJ ASSY
745-1	X1756745-1	HANDLE
745-2	XPSS08	SET SCREW 5/16-18 X 1/2
745-3	X1756745-3	ADJUSTMENT RING
746	XPB03	HEX BOLT 5/16-18 X 1
747	XPW07	FLAT WASHER 5/16
748	X1756748	HANDLE
749	X1757749	BEARING HOUSING (W1757)
750	X1757750	RUBBER ROLLER (W1757)
751	X1757751	FASTENING TUBE (W1757)
753	X1757753	PULLEY (W1757)
754	XPSB11	CAP SCREW 5/16-18 X 1-1/4 (W1757)
755	X1757755	BEARING HOUSING (W1757)
756	X1757756	BEARING BRACKET PAD (W1757)
757	XP6206	BALL BEARING 6206ZZ (W1757)
758	X1757758	SPANNER CAP (W1757)
759	X1757759	BEARING CAP (W1757)
760	X1757760	PULLEY COVER (W1757)
761	X1756761	PISTON SLIDERAIL (W1756)
761	X1757761	PISTON SLIDERAIL (W1757)
762	X1756762	PISTON BRACKET (W1756)
762	X1757762	PISTON BRACKET (W1757)
763	X1756763	COMPRESSION SPRING
764	X1756764	ALIGNMENT PIN 10 X 35
765	XPSB04	CAP SCREW 1/4-20 X 1/2 (W1756)
765	XPSS07	SET SCREW 1/4-20 X 1/2 (W1757)
766	XPB11	HEX BOLT 5/16-18 X 1-1/2
767	XPNO8	HEX NUT 3/8-16 (W1757)
768	XPB12	HEX BOLT 5/16-18 X 1-1/4
769	XPLW01	LOCK WASHER 5/16
770	XPNO2	HEX NUT 5/16-18
771	X1756771	PISTON ROLLER ASSEMBLY (W1756)
771	X1757771	PISTON ROLLER ASSEMBLY (W1757)
771-1	X1756771-1	PISTON ROLLER SHAFT (W1756)
771-1	X1757771-1	PISTON ROLLER SHAFT (W1757)
771-2	X1756771-2	PISTON ROLLER (W1756)
771-2	X1757771-2	PISTON ROLLER (W1757)
771-3	XP6003	BALL BEARING 6003ZZ
771-4	X1756771-4	SHAFT BEARING COLLAR (W1756)
771-4	X1757771-4	SHAFT BEARING COLLAR (W1757)
771-5	XPSS03	SET SCREW 1/4-20 X 3/8 (W1756)
771-5	XPSS07	SET SCREW 1/4-20 X 1/2 (W1757)
771-6	XPNO5	HEX NUT 1/4-20 (W1757)
772	X1757772	GUIDE STUD (W1757)
773	X1757773	PISTON BRACKET (MIDDLE, W1757)
774	XPRP55M	ROLL PIN 3 X 27 (W1757)

Label Placement

⚠️ WARNING

Safety labels warn about machine hazards and how to prevent machine damage or injury. The owner of this machine **MUST** maintain the original location and readability of all labels on this machine. If any label is removed or becomes unreadable, **REPLACE** that label before allowing the machine to enter service again. Contact Woodstock International, Inc. at (360) 734-3482 or www.shopfoxtools.com to order new labels.

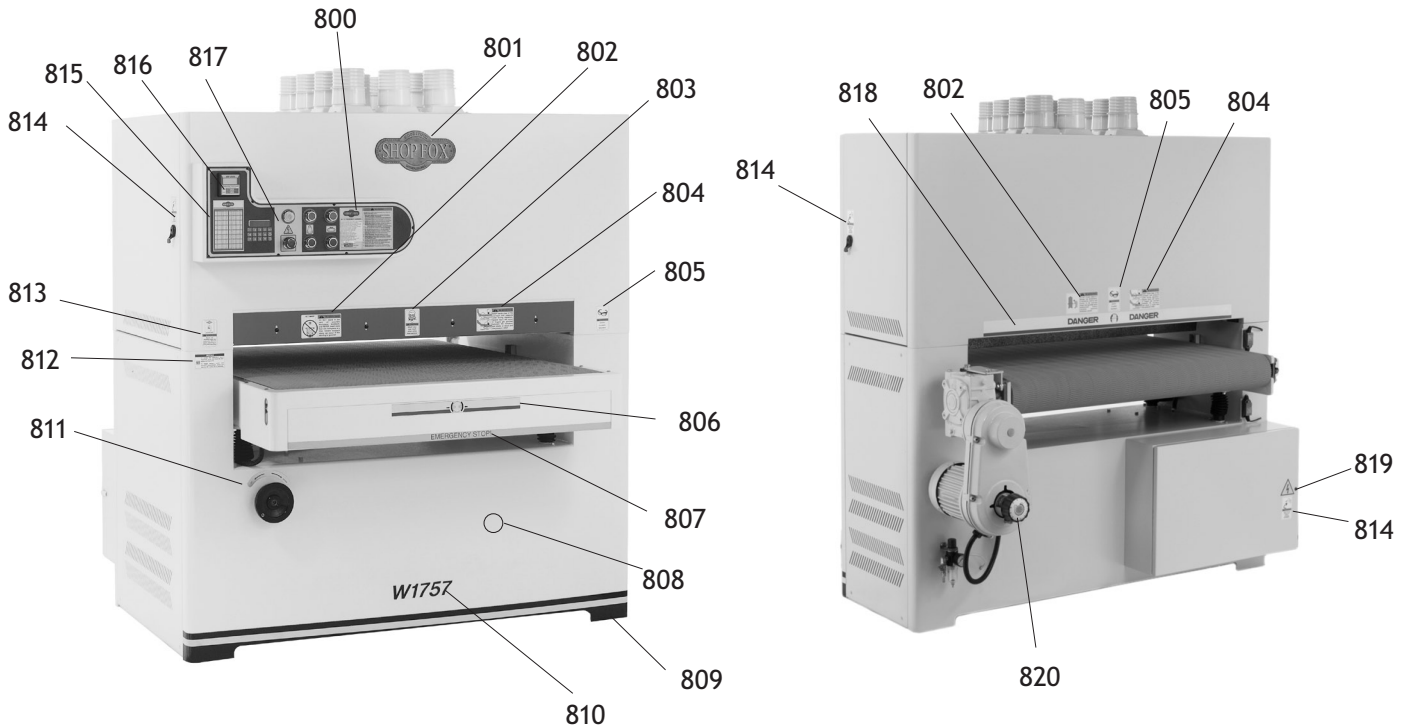

REF	PART #	DESCRIPTION
800	X1756800	MACHINE ID LABEL (W1756)
800	X1757800	MACHINE ID LABEL (W1757)
801	X1756801	SHOP FOX LOG PLATE
802	X1756802	SANDER KICKBACK LABEL
803	X1756803	DUST MASK LABEL
804	X1756804	HAND PINCH LABEL
805	XLABEL-11	SAFETY GLASSES LABEL
806	X1756806	BRAKE LABEL
807	X1756807	EMERGENCY STOP STRIPE LABEL
808	XPPAINT-1	SHOP FOX WHITE TOUCH UP PAINT
809	X1756809	DECORATIVE STRIPING
810	X1756810	MODEL W1756 LABEL

REF	PART #	DESCRIPTION
810	X1757810	MODEL W1757 LABEL
811	X1756811	ROTATION LABEL
812	X1756812	NOTICE LABEL
813	XLABEL-12	READ MANUAL LABEL
814	X1756814	DISCONNECT POWER LABEL
815	X1756815	CONVERSION CHART LABEL
816	X1756816	AMP LOAD METER LABEL
817	X1756817	CONTROL PANEL LABEL
818	X1756818	DANGER STRIP LABEL
819	XLABEL-04	ELECTRICITY LABEL
820	X1756820	SPEED LABEL



Warranty Registration

Name _____
 Street _____
 City _____ State _____ Zip _____
 Phone # _____ Email _____ Invoice # _____
 Model # _____ Serial # _____ Dealer Name _____ Purchase Date _____

The following information is given on a voluntary basis. It will be used for marketing purposes to help us develop better products and services. **Of course, all information is strictly confidential.**

- How did you learn about us?

<input type="checkbox"/> Advertisement	<input type="checkbox"/> Friend	<input type="checkbox"/> Local Store
<input type="checkbox"/> Mail Order Catalog	<input type="checkbox"/> Website	<input type="checkbox"/> Other:
- How long have you been a woodworker/metalworker?

<input type="checkbox"/> 0-2 Years	<input type="checkbox"/> 2-8 Years	<input type="checkbox"/> 8-20 Years	<input type="checkbox"/> 20+ Years
------------------------------------	------------------------------------	-------------------------------------	------------------------------------
- How many of your machines or tools are Shop Fox?

<input type="checkbox"/> 0-2	<input type="checkbox"/> 3-5	<input type="checkbox"/> 6-9	<input type="checkbox"/> 10+
------------------------------	------------------------------	------------------------------	------------------------------
- Do you think your machine represents a good value? Yes No
- Would you recommend Shop Fox products to a friend? Yes No
- What is your age group?

<input type="checkbox"/> 20-29	<input type="checkbox"/> 30-39	<input type="checkbox"/> 40-49
<input type="checkbox"/> 50-59	<input type="checkbox"/> 60-69	<input type="checkbox"/> 70+
- What is your annual household income?

<input type="checkbox"/> \$20,000-\$29,000	<input type="checkbox"/> \$30,000-\$39,000	<input type="checkbox"/> \$40,000-\$49,000
<input type="checkbox"/> \$50,000-\$59,000	<input type="checkbox"/> \$60,000-\$69,000	<input type="checkbox"/> \$70,000+
- Which of the following magazines do you subscribe to?

<input type="checkbox"/> Cabinet Maker	<input type="checkbox"/> Popular Mechanics	<input type="checkbox"/> Today's Homeowner
<input type="checkbox"/> Family Handyman	<input type="checkbox"/> Popular Science	<input type="checkbox"/> Wood
<input type="checkbox"/> Hand Loader	<input type="checkbox"/> Popular Woodworking	<input type="checkbox"/> Wooden Boat
<input type="checkbox"/> Handy	<input type="checkbox"/> Practical Homeowner	<input type="checkbox"/> Woodshop News
<input type="checkbox"/> Home Shop Machinist	<input type="checkbox"/> Precision Shooter	<input type="checkbox"/> Woodsmith
<input type="checkbox"/> Journal of Light Cont.	<input type="checkbox"/> Projects in Metal	<input type="checkbox"/> Woodwork
<input type="checkbox"/> Live Steam	<input type="checkbox"/> RC Modeler	<input type="checkbox"/> Woodworker West
<input type="checkbox"/> Model Airplane News	<input type="checkbox"/> Rifle	<input type="checkbox"/> Woodworker's Journal
<input type="checkbox"/> Modeltec	<input type="checkbox"/> Shop Notes	<input type="checkbox"/> Other:
<input type="checkbox"/> Old House Journal	<input type="checkbox"/> Shotgun News	

9. Comments: _____

CUT ALONG DOTTED LINE

FOLD ALONG DOTTED LINE

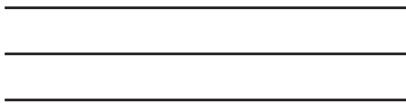

Place
Stamp
Here



WOODSTOCK INTERNATIONAL INC.
P.O. BOX 2309
BELLINGHAM, WA 98227-2309



FOLD ALONG DOTTED LINE

TAPE ALONG EDGES--PLEASE DO NOT STAPLE

Warranty

Woodstock International, Inc. warrants all Shop Fox machinery to be free of defects from workmanship and materials for a period of two years from the date of original purchase by the original owner. This warranty does not apply to defects due directly or indirectly to misuse, abuse, negligence or accidents, lack of maintenance, or reimbursement of third party expenses incurred.

Woodstock International, Inc. will repair or replace, at its expense and at its option, the Shop Fox machine or machine part which in normal use has proven to be defective, provided that the original owner returns the product prepaid to a Shop Fox factory service center with proof of their purchase of the product within two years, and provides Woodstock International, Inc. reasonable opportunity to verify the alleged defect through inspection. If it is determined there is no defect, or that the defect resulted from causes not within the scope of Woodstock International Inc.'s warranty, then the original owner must bear the cost of storing and returning the product.

This is Woodstock International, Inc.'s sole written warranty and any and all warranties that may be implied by law, including any merchantability or fitness, for any particular purpose, are hereby limited to the duration of this written warranty. We do not warrant that Shop Fox machinery complies with the provisions of any law or acts. In no event shall Woodstock International, Inc.'s liability under this warranty exceed the purchase price paid for the product, and any legal actions brought against Woodstock International, Inc. shall be tried in the State of Washington, County of Whatcom. We shall in no event be liable for death, injuries to persons or property or for incidental, contingent, special or consequential damages arising from the use of our products.

Every effort has been made to ensure that all Shop Fox machinery meets high quality and durability standards. We reserve the right to change specifications at any time because of our commitment to continuously improve the quality of our products.

