

MODEL W1669/W1670 RADIAL DRILL PRESS



OWNER'S MANUAL

(FOR MODELS MANUFACTURED SINCE 06/22)

Phone: (360) 734-3482 • Online Technical Support: techsupport@woodstockint.com

COPYRIGHT © DECEMBER, 2003 BY WOODSTOCK INTERNATIONAL, INC., REVISED JUNE, 2022 (CS)

WARNING: NO PORTION OF THIS MANUAL MAY BE REPRODUCED IN ANY SHAPE OR FORM WITHOUT

THE WRITTEN APPROVAL OF WOODSTOCK INTERNATIONAL, INC.



WARNING!

This manual provides critical safety instructions on the proper setup, operation, maintenance, and service of this machine/tool. Save this document, refer to it often, and use it to instruct other operators.

Failure to read, understand and follow the instructions in this manual may result in fire or serious personal injury—including amputation, electrocution, or death.

The owner of this machine/tool is solely responsible for its safe use. This responsibility includes but is not limited to proper installation in a safe environment, personnel training and usage authorization, proper inspection and maintenance, manual availability and comprehension, application of safety devices, cutting/sanding/grinding tool integrity, and the usage of personal protective equipment.

The manufacturer will not be held liable for injury or property damage from negligence, improper training, machine modifications or misuse.



WARNING!

Some dust created by power sanding, sawing, grinding, drilling, and other construction activities contains chemicals known to the State of California to cause cancer, birth defects or other reproductive harm. Some examples of these chemicals are:

- Lead from lead-based paints.
- Crystalline silica from bricks, cement and other masonry products.
- Arsenic and chromium from chemically-treated lumber.

Your risk from these exposures varies, depending on how often you do this type of work. To reduce your exposure to these chemicals: Work in a well ventilated area, and work with approved safety equipment, such as those dust masks that are specially designed to filter out microscopic particles.

Contents

| | | | |
|----------------------------------------------|-----------|---------------------------------------------|-----------|
| INTRODUCTION | 2 | ACCESSORIES | 36 |
| Woodstock Technical Support | 2 | Drill Press Accessories | 36 |
| Identification | 7 | MAINTENANCE | 37 |
| Controls & Components | 8 | General | 37 |
| SAFETY | 9 | Cleaning & Protecting | 37 |
| Standard Machinery Safety Instructions | 9 | Lubrication | 37 |
| Additional Safety for Drill Presses..... | 11 | Inspecting/Replacing V-Belts | 37 |
| ELECTRICAL | 12 | SERVICE | 38 |
| Circuit Requirements | 12 | General | 38 |
| Grounding Requirements..... | 13 | Adjusting Belt Tension..... | 38 |
| Extension Cords | 13 | Calibrating Depth Stop | 39 |
| SETUP | 14 | Adjusting Spindle Return Spring Tension ... | 39 |
| Unpacking | 14 | Adjusting Quill-Shaft Screw | 41 |
| Items Needed for Setup..... | 14 | Troubleshooting..... | 42 |
| Inventory | 15 | Electrical Safety Instructions..... | 44 |
| Cleaning Machine..... | 16 | Wiring Diagram | 45 |
| Machine Placement | 17 | PARTS | 46 |
| Mounting to Bench (W1669) | 18 | Headstock | 46 |
| Anchoring to Floor (W1670) | 18 | W1669 Table & Column..... | 48 |
| Mounting W1670 to Mobile Base | 19 | W1670 Table & Column..... | 50 |
| Assembly..... | 20 | Labels & Cosmetics | 52 |
| Joining Drill Chuck & Arbor..... | 24 | WARRANTY | 53 |
| Test Run..... | 25 | | |
| OPERATIONS | 26 | | |
| General | 26 | | |
| Drill Press RPM Chart | 27 | | |
| Lubrication Suggestions | 27 | | |
| Changing Speeds | 30 | | |
| Drilling | 31 | | |
| Installing/Removing Drill Bits | 32 | | |
| Adjusting Depth Stop | 33 | | |
| Adjusting Table | 34 | | |
| Adjusting Headstock | 35 | | |





INTRODUCTION

Woodstock Technical Support

This machine has been specially designed to provide many years of trouble-free service. Close attention to detail, ruggedly built parts and a rigid quality control program assure safe and reliable operation.

Woodstock International, Inc. is committed to customer satisfaction. Our intent with this manual is to include the basic information for safety, setup, operation, maintenance, and service of this product.

We stand behind our machines! In the event that questions arise about your machine, please contact Woodstock International Technical Support at (360) 734-3482 Ext. 2 or send e-mail to: techsupport@woodstockint.com. Our knowledgeable staff will help you troubleshoot problems and process warranty claims.

If you need the latest edition, you can download it from <http://www.woodstockint.com/manuals>.
If you have comments about this manual, please contact us at:

Woodstock International, Inc.
Attn: Technical Documentation Manager
P.O. Box 2309
Bellingham, WA 98227
Email: manuals@woodstockint.com



MACHINE SPECIFICATIONS



© Woodstock International, Inc. • Phone #: (800) 840-8420 • Web: www.woodstockint.com

MODEL W1669 1/2 HP 34" BENCH-TOP RADIAL DRILL PRESS

Product Dimensions

Weight..... 91 lbs.
 Width (side-to-side) x Depth (front-to-back) x Height..... 12 x 33-1/2 x 31-1/2 in.
 Footprint (Length x Width)..... 13-1/2 x 8-1/2 in.

Shipping Dimensions

Type..... Cardboard Box
 Content..... Machine
 Weight..... 98 lbs.
 Length x Width x Height..... 36 x 18 x 13 in.

Electrical

Power Requirement..... 120V, Single-Phase, 60 Hz
 Full-Load Current Rating..... 4.7A
 Minimum Circuit Size..... 15A
 Connection Type..... Cord & Plug
 Power Cord Included..... Yes
 Power Cord Length..... 7 ft.
 Power Cord Gauge..... 18 AWG
 Plug Included..... Yes
 Included Plug Type..... 5-15
 Switch Type..... Toggle Safety Switch w/Removable Key

Motors

Main

Horsepower..... 1/2 HP
 Phase..... Single-Phase
 Amps..... 4.7A
 Speed..... 1725 RPM
 Type..... TEFC Capacitor-Start Induction
 Power Transfer V-Belt Drive
 Bearings..... Shielded & Permanently Lubricated



Main Specifications

Operation Information

| | |
|-------------------------------------------|------------------|
| Type..... | Radial |
| Swing..... | 34 in. |
| Spindle Taper..... | JT#33 |
| Spindle Travel..... | 3-1/4 in. |
| Max. Distance From Spindle to Column..... | 5-1/2 - 17 in. |
| Max. Distance From Spindle to Table..... | 11-1/2 in. |
| Number of Spindle Speeds..... | 5 |
| Range of Spindle Speeds..... | 550 - 3000 RPM |
| Max. Head Tilt (Left/Right)..... | 90 / 45 deg. |
| Max. Head Swivel..... | 360 deg. |
| Drilling Capacity (Mild Steel)..... | 1/2 in. in Steel |
| Drill Chuck Type..... | JT33 Key Chuck |
| Drill Chuck Size..... | 1/16 - 5/8 in. |

Spindle Information

| | |
|------------------------------------|------------|
| Distance From Spindle to Base..... | 17-1/2 in. |
| Quill Diameter..... | 1.575 in. |

Table Information

| | |
|-----------------------------------|------------------------|
| Max. Table Tilt (Left/Right)..... | 90 deg. |
| Table Swing..... | 360 deg. |
| Table Swivel Around Center..... | 360 deg. |
| Table Swivel Around Column..... | 360 deg. |
| Max. Movement of Work Table..... | 9-1/2 in. |
| Table Length..... | (Diameter) 9-3/4 in. |
| Table Width..... | (Diameter) 9-3/4 in. |
| Table Thickness..... | 1 in. |
| Vertical Table Travel..... | Crank Handle Operation |
| Number of T-Slots..... | 6 |
| T-Slot Size..... | 1/2 in. |
| T-Slot Centers..... | 2-3/4 in. |
| Floor-To-Table Height..... | 7-3/4 - 17-1/4 in. |

Construction

| | |
|------------------------|----------------------------|
| Table..... | Precision-Ground Cast Iron |
| Column..... | Steel |
| Spindle Housing..... | Cast Iron |
| Head..... | Cast Iron |
| Base..... | Cast Iron |
| Paint Type/Finish..... | Enamel |

Other Related Information

| | |
|----------------------|---------------------------------|
| Base Length..... | 13-1/2 in. |
| Base Width..... | 8-1/2 in. |
| Column Diameter..... | 2.360 in. |
| Depth Stop Type..... | Threaded Rod with Positive Stop |
| Has Work Light..... | No |



MACHINE SPECIFICATIONS



© Woodstock International, Inc. • Phone #: (800) 840-8420 • Web: www.woodstockint.com

MODEL W1670 1/2 HP 34" FLOOR RADIAL DRILL PRESS

Product Dimensions

Weight..... 138 lbs.
 Width (side-to-side) x Depth (front-to-back) x Height..... 14 x 32 x 64-1/2 in.
 Footprint (Length x Width)..... 18 x 11 in.

Shipping Dimensions

Type..... Cardboard Box
 Content..... Machine
 Weight..... 147 lbs.
 Length x Width x Height..... 20 x 56 x 10 in.

Electrical

Power Requirement..... 120V, Single-Phase, 60 Hz
 Full-Load Current Rating..... 4.7A
 Minimum Circuit Size..... 15A
 Connection Type..... Cord & Plug
 Power Cord Included..... Yes
 Power Cord Length..... 7 ft.
 Power Cord Gauge..... 18 AWG
 Plug Included..... Yes
 Included Plug Type..... 5-15
 Switch Type..... Toggle Safety Switch w/Removable Key

Motors

Main

Horsepower..... 1/2 HP
 Phase..... Single-Phase
 Amps..... 4.7A
 Speed..... 1725 RPM
 Type..... TEFC Capacitor-Start Induction
 Power Transfer V-Belt Drive
 Bearings..... Shielded & Permanently Lubricated



Main Specifications

Operation Information

| | |
|-------------------------------------------|----------------|
| Type..... | Radial |
| Swing..... | 34 in. |
| Spindle Taper..... | JT#33 |
| Spindle Travel..... | 3-1/4 in. |
| Max. Distance From Spindle to Column..... | 5-1/2 - 17 in. |
| Max. Distance From Spindle to Table..... | 29-1/2 in. |
| Number of Spindle Speeds..... | 5 |
| Range of Spindle Speeds..... | 550 - 3000 RPM |
| Max. Head Tilt (Left/Right)..... | 90 / 45 deg. |
| Max. Head Swivel..... | 360 deg. |
| Drilling Capacity (Mild Steel)..... | 1/2 in. |
| Drill Chuck Type..... | JT33 Key Chuck |
| Drill Chuck Size..... | 1/16 - 5/8 in. |

Spindle Information

| | |
|------------------------------------|------------|
| Distance From Spindle to Base..... | 49-3/4 in. |
| Quill Diameter..... | 1.575 in. |

Table Information

| | |
|-----------------------------------|------------------------|
| Max. Table Tilt (Left/Right)..... | 90 deg. |
| Table Swing..... | 360 deg. |
| Table Swivel Around Center..... | 360 deg. |
| Table Swivel Around Column..... | 360 deg. |
| Max. Movement of Work Table..... | 24-1/2 in. |
| Table Diameter..... | 12-3/16 in. |
| Table Thickness..... | 1 in. |
| Vertical Table Travel..... | Crank Handle Operation |
| Number of T-Slots..... | 6 |
| T-Slot Size..... | 5/8 in. |
| T-Slot Centers..... | 3-1/4 in. |
| Floor-To-Table Height..... | 22-1/2 - 47 in. |

Construction

| | |
|------------------------|----------------------------|
| Table..... | Precision-Ground Cast Iron |
| Column..... | Steel |
| Spindle Housing..... | Cast Iron |
| Head..... | Cast Iron |
| Base..... | Cast Iron |
| Paint Type/Finish..... | Enamel |

Other Related Information

| | |
|----------------------|------------|
| Base Length..... | 17-1/2 in. |
| Base Width..... | 10-1/2 in. |
| Mobile Base..... | D2260A |
| Column Diameter..... | 2.790 in. |
| Depth Stop Type..... | Hub |
| Has Work Light..... | No |

Identification

Become familiar with the names and locations of the controls and features shown below to better understand the instructions in this manual.

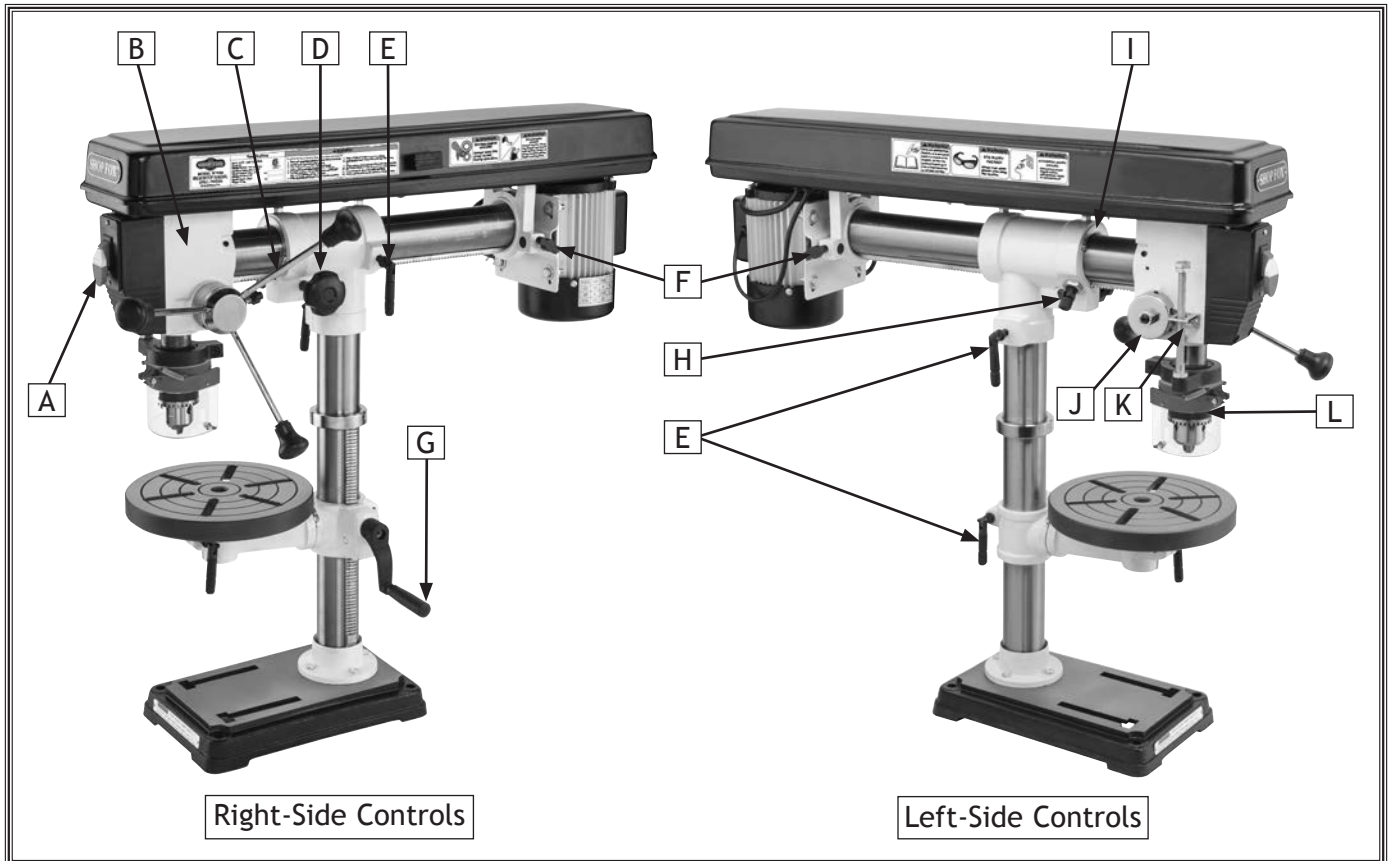

- A. Power Switch
- B. Headstock
- C. Downfeed Handles
- D. Horizontal Adjustment Knob
- E. Lock Levers
- F. Belt Tension Lock Knobs

- G. Crank Handle
- H. Lock Pin
- I. Headstock Angle Tilt Scale
- J. Spindle Return Spring
- K. Depth Stop
- L. Chuck Guard & Chuck

⚠ WARNING



To reduce your risk of serious injury or damage to the machine, read this entire manual **BEFORE** using machine.

Controls & Components

Refer to the following figures and descriptions to become familiar with the basic controls and components of this machine. Understanding these items and how they work will help you understand the rest of the manual and stay safe when operating this machine.

- A. **Power Switch:** Turns motor ON/OFF.
- B. **Headstock:** The cast-iron upper portion of the drill press, which houses the quill and supports the motor and belt housing.
- C. **Belt Cover:** Provides access to drive belt for spindle-speed changes.
- D. **Belt Tension Lock Knobs:** Secure motor in position to set belt tension.
- E. **Headstock Rotation Lock Lever:** Locks headstock in position.
- F. **Horizontal Adjustment Knob:** Moves the headstock forward and backward over the column.
- G. **Downfeed Handles:** Move the quill up and down.
- H. **Table Height Crank Handle:** Raises/lowers table.
- I. **Table Rotation Lock Lever:** Locks table rotation.
- J. **Chuck Guard & Chuck:** Chuck guard protects user from flying debris; chuck accepts drill bits from $\frac{1}{64}$ " to $\frac{5}{8}$ " and mounts to the spindle with a JT#33 taper.
- K. **Lock Pin:** When pulled out, allows headstock to be tilted left/right.
- L. **Scale:** Indicates headstock angle.
- M. **Spindle Return Spring:** Automatically returns quill into headstock.
- N. **Depth Stop:** Limits quill travel to a pre-set drilling depth.
- O. **Spindle:** Used to mount chuck and accessories with a JT#33 taper.
- P. **Table Elevation Lock Lever:** Locks table height.
- Q. **Column Lock Lever:** Locks headstock on column.

⚠ WARNING



To reduce your risk of serious injury or damage to the machine, read this entire manual **BEFORE** using machine.

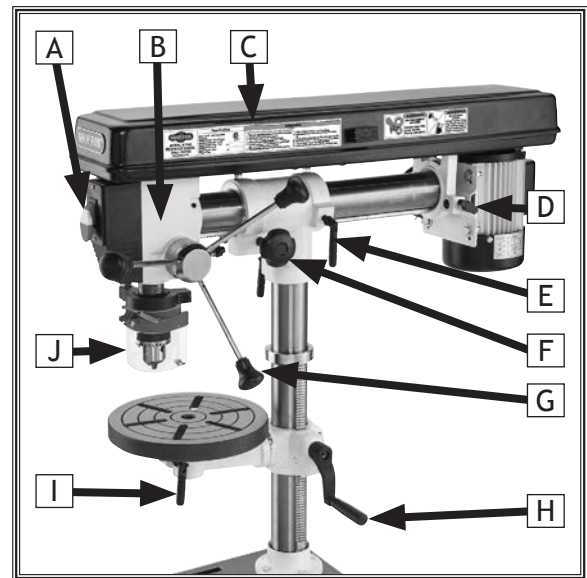

Figure 1. Machine controls (right).

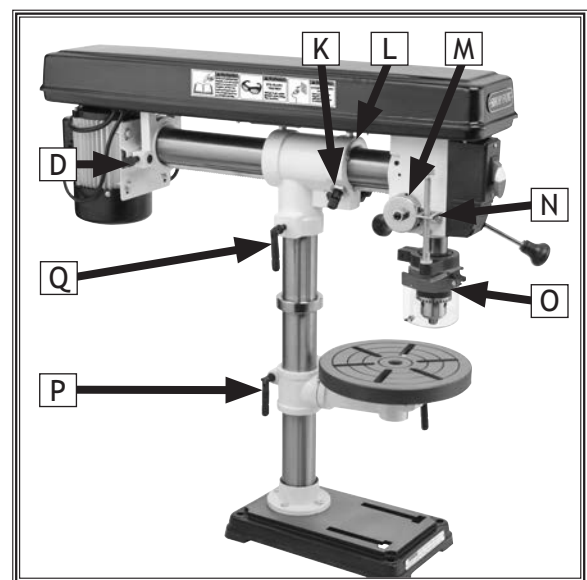

Figure 2. Machine controls (left).

SAFETY

For Your Own Safety, Read Manual Before Operating Machine

The purpose of safety symbols is to attract your attention to possible hazardous conditions. This manual uses a series of symbols and signal words intended to convey the level of importance of the safety messages. The progression of symbols is described below. Remember that safety messages by themselves do not eliminate danger and are not a substitute for proper accident prevention measures—this responsibility is ultimately up to the operator!



Indicates an imminently hazardous situation which, if not avoided, **WILL** result in death or serious injury.



Indicates a potentially hazardous situation which, if not avoided, **COULD** result in death or serious injury.



Indicates a potentially hazardous situation which, if not avoided, **MAY** result in minor or moderate injury.

NOTICE

This symbol is used to alert the user to useful information about proper operation of the equipment or a situation that may cause damage to the machinery.

Standard Machinery Safety Instructions

OWNER'S MANUAL. Read and understand this owner's manual **BEFORE** using machine.

TRAINED OPERATORS ONLY. Untrained operators have a higher risk of being hurt or killed. Only allow trained/supervised people to use this machine. When machine is not being used, disconnect power, remove switch keys, or lock-out machine to prevent unauthorized use—especially around children. Make workshop kid proof!

DANGEROUS ENVIRONMENTS. Do not use machinery in areas that are wet, cluttered, or have poor lighting. Operating machinery in these areas greatly increases the risk of accidents and injury.

MENTAL ALERTNESS REQUIRED. Full mental alertness is required for safe operation of machinery. Never operate under the influence of drugs or alcohol, when tired, or when distracted.

ELECTRICAL EQUIPMENT INJURY RISKS. You can be shocked, burned, or killed by touching live electrical components or improperly grounded machinery. To reduce this risk, only allow an electrician or qualified service personnel to do electrical installation or repair work, and always disconnect power before accessing or exposing electrical equipment.

DISCONNECT POWER FIRST. Always disconnect machine from power supply **BEFORE** making adjustments, changing tooling, or servicing machine. This eliminates the risk of injury from unintended startup or contact with live electrical components.

EYE PROTECTION. Always wear ANSI-approved safety glasses or a face shield when operating or observing machinery to reduce the risk of eye injury or blindness from flying particles. Everyday eyeglasses are not approved safety glasses.

WEARING PROPER APPAREL. Do not wear clothing, apparel, or jewelry that can become entangled in moving parts. Always tie back or cover long hair. Wear non-slip footwear to avoid accidental slips, which could cause loss of workpiece control.

HAZARDOUS DUST. Dust created while using machinery may cause cancer, birth defects, or long-term respiratory damage. Be aware of dust hazards associated with each workpiece material, and always wear a NIOSH-approved respirator to reduce your risk.

HEARING PROTECTION. Always wear hearing protection when operating or observing loud machinery. Extended exposure to this noise without hearing protection can cause permanent hearing loss.

REMOVE ADJUSTING TOOLS. Tools left on machinery can become dangerous projectiles upon startup. Never leave chuck keys, wrenches, or any other tools on machine. Always verify removal before starting!

INTENDED USAGE. Only use machine for its intended purpose—never make modifications without prior approval from Woodstock International. Modifying machine or using it differently than intended will void the warranty and may result in malfunction or mechanical failure that leads to serious personal injury or death!

AWKWARD POSITIONS. Keep proper footing and balance at all times when operating machine. Do not overreach! Avoid awkward hand positions that make workpiece control difficult or increase the risk of accidental injury.

CHILDREN & BYSTANDERS. Keep children and bystanders at a safe distance from the work area. Stop using machine if they become a distraction.

GUARDS & COVERS. Guards and covers reduce accidental contact with moving parts or flying debris—make sure they are properly installed, undamaged, and working correctly.

FORCING MACHINERY. Do not force machine. It will do the job safer and better at the rate for which it was designed.

NEVER STAND ON MACHINE. Serious injury may occur if machine is tipped or if the cutting tool is unintentionally contacted.

STABLE MACHINE. Unexpected movement during operation greatly increases risk of injury or loss of control. Before starting, verify machine is stable and mobile base (if used) is locked.

USE RECOMMENDED ACCESSORIES. Consult this owner's manual or the manufacturer for recommended accessories. Using improper accessories will increase risk of serious injury.

UNATTENDED OPERATION. To reduce the risk of accidental injury, turn machine **OFF** and ensure all moving parts completely stop before walking away. Never leave machine running while unattended.

MAINTAIN WITH CARE. Follow all maintenance instructions and lubrication schedules to keep machine in good working condition. A machine that is improperly maintained could malfunction, leading to serious personal injury or death.

CHECK DAMAGED PARTS. Regularly inspect machine for any condition that may affect safe operation. Immediately repair or replace damaged or mis-adjusted parts before operating machine.

MAINTAIN POWER CORDS. When disconnecting cord-connected machines from power, grab and pull the plug—NOT the cord. Pulling the cord may damage the wires inside, resulting in a short. Do not handle cord/plug with wet hands. Avoid cord damage by keeping it away from heated surfaces, high traffic areas, harsh chemicals, and wet/damp locations.

EXPERIENCING DIFFICULTIES. If at any time you experience difficulties performing the intended operation, stop using the machine! Contact Technical Support at (360) 734-3482.

Additional Safety for Drill Presses

Serious injury or death can occur from getting clothing, jewelry, or long hair entangled in rotating spindle or bit/cutting tool. Contact with rotating bit/cutting tool can result in severe cuts or amputation of fingers. Flying metal chips can cause blindness or eye injuries. Broken bits/cutting tools, unsecured workpieces, chuck keys, or other adjustment tools thrown from rotating spindle can strike nearby operator or bystanders with great force. To reduce the risk of these hazards, operator and bystanders **MUST** completely heed hazards and warnings below.

WEARING PROPER PPE. Flying chips created by drilling can cause eye injuries or blindness. Always wear a face shield in addition to safety glasses. Always keep hands and fingers away from drill bit/cutting tool. Avoid awkward hand positions, where a sudden slip could cause hand to move into bit/cutting tool.

AVOIDING ENTANGLEMENT. DO NOT wear loose clothing, gloves, or jewelry, and tie back long hair. Keep all guards in place and secure. Always allow spindle to stop on its own. DO NOT stop spindle using your hand or any other object.

REMOVING ADJUSTMENT TOOLS. Chuck key, drawbar wrench, and other tools left on machine can become deadly projectiles when spindle is started. Remove all loose items or tools used on spindle immediately after use.

SECURING BIT/CUTTING TOOL. Firmly secure bit/cutting tool so it does not fly out of spindle during operation or startup.

SECURING TABLE AND HEADSTOCK. To avoid accidental contact with tool/bit, tighten all table and headstock locks before operating drill.

CORRECT SPINDLE SPEED. Using wrong spindle speed can cause bits/cutting tools to break and strike operator or bystanders. Follow recommended speeds and feeds for each size/type of bit/cutting tool and workpiece material.

WORKPIECE PREPARATION. To avoid loss of workpiece control, DO NOT drill material with an uneven surface on the table, unless a suitable support is used. To avoid impact injuries, make sure workpiece is free of nails or foreign objects in area to be drilled.

WORKPIECE CONTROL. An unsecured workpiece may unexpectedly shift, spin out of control, or be thrown if bit/cutting tool “grabs” during operation. Clamp workpiece to table or in table-mounted vise, or brace against column to prevent rotation. NEVER hold workpiece by hand during operation. NEVER start machine with bit/cutting tool touching workpiece; allow spindle to gain full speed before drilling.

INSPECTING BIT/CUTTING TOOL. Damaged bits/cutting tools may break apart during operation and hit operator or bystanders. Dull bits/cutting tools increase cutting resistance and are more likely to grab and spin/throw workpiece. Always inspect bits/cutting tools for sharpness, chips, or cracks before each use. Replace dull, chipped, or cracked bits/cutting tools immediately.

MAINTAINING MACHINE. Keep machine in proper working condition to help ensure that it functions safely and all guards and other components work as intended. Perform routine inspections and all necessary maintenance. Never operate machine with damaged or worn parts that can break or result in unexpected movement during operation.

CLEANING MACHINE SAFELY. To avoid contact with tool/bit, never clear chips while spindle is turning. To avoid cuts and eye injuries, DO NOT clear chips by hand or with compressed air—use a brush or vacuum instead.

DISCONNECT POWER FIRST. To reduce risk of electrocution or injury from unexpected startup, make sure drill is turned OFF, disconnected from power, and all moving parts have come to a complete stop before changing bits/cutting tools or starting any inspection, adjustment, or maintenance procedure.

ELECTRICAL

Circuit Requirements

This machine must be connected to the correct size and type of power supply circuit, or fire or electrical damage may occur. Read through this section to determine if an adequate power supply circuit is available. If a correct circuit is not available, a qualified electrician **MUST** install one before you can connect the machine to power.

A power supply circuit includes all electrical equipment between the breaker box or fuse panel in the building and the machine. The power supply circuit used for this machine must be sized to safely handle the full-load current drawn from the machine for an extended period of time. (If this machine is connected to a circuit protected by fuses, use a time delay fuse marked D.)

Full-Load Current Rating

The full-load current rating is the amperage a machine draws at 100% of the rated output power. On machines with multiple motors, this is the amperage drawn by the largest motor or sum of all motors and electrical devices that might operate at one time during normal operations.

Full-Load Current Rating at 120V (W1669) 4.7 Amps

Full-Load Current Rating at 120V (W1670) 4.7 Amps

Circuit Requirements for 120V

This machine is prewired to operate on a power supply circuit that has a verified ground and meets the following requirements:

Circuit Type 110V/120V, 60 Hz, Single-Phase

Circuit Size 15 Amps

Plug/Receptacle NEMA 5-15

ELECTRICAL

⚠ WARNING

The machine must be properly set up before it is safe to operate. **DO NOT** connect this machine to the power source until instructed to do so later in this manual.

⚠ WARNING



Incorrectly wiring or grounding this machine can cause electrocution, fire, or machine damage. To reduce this risk, only an electrician or qualified service personnel should do any required electrical work on this machine.

NOTICE

The circuit requirements listed in this manual apply to a dedicated circuit—where only one machine will be running at a time. If this machine will be connected to a shared circuit where multiple machines will be running at the same time, consult with an electrician to ensure that the circuit is properly sized for safe operation.

Grounding Requirements

This machine **MUST** be grounded. In the event of certain types of malfunctions or breakdowns, grounding provides a path of least resistance for electric current to travel—in order to reduce the risk of electric shock.

Improper connection of the equipment-grounding wire will increase the risk of electric shock. The wire with green insulation (with/without yellow stripes) is the equipment-grounding wire. If repair or replacement of the power cord or plug is necessary, do not connect the equipment-grounding wire to a live (current carrying) terminal.

Check with a qualified electrician or service personnel if you do not understand these grounding requirements, or if you are in doubt about whether the tool is properly grounded. If you ever notice that a cord or plug is damaged or worn, disconnect it from power, and immediately replace it with a new one.

For 120V Connection

This machine is equipped with a power cord with an equipment-grounding wire and NEMA 5-15 grounding plug (see figure). The plug must only be inserted into a matching receptacle that is properly installed and grounded in accordance with local codes and ordinances.

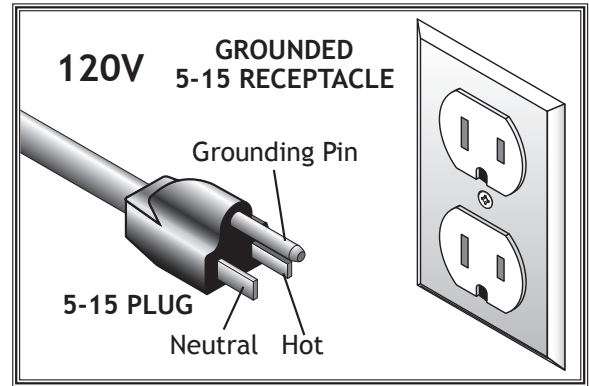
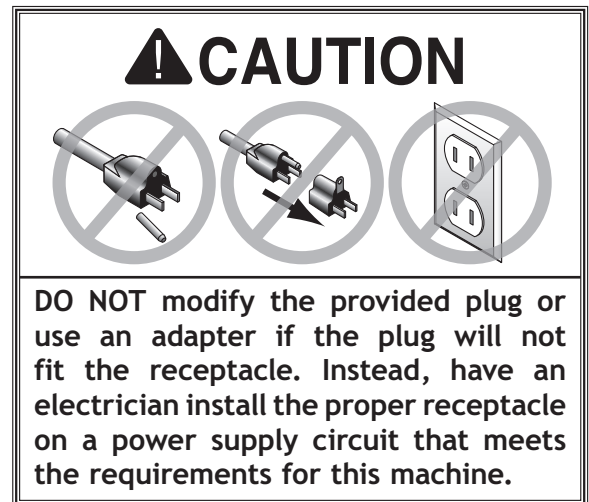

Figure 3. NEMA 5-15 plug & receptacle.



Extension Cords

We do not recommend using an extension cord with this machine. Extension cords cause voltage drop, which may damage electrical components and shorten motor life. Voltage drop increases with longer extension cords and smaller gauge sizes (higher gauge numbers indicate smaller sizes).

Any extension cord used with this machine must contain a ground wire, match the required plug and receptacle, and meet the following requirements:

- Minimum Gauge Size at 120V 14 AWG
- Maximum Length (Shorter is Better) 50 ft.

ELECTRICAL

SETUP

Unpacking

This machine has been carefully packaged for safe transportation. If you notice the machine has been damaged during shipping, please contact your authorized Shop Fox dealer immediately.

Items Needed for Setup

The following items are needed, but not included, to set up your machine.

| Description | Qty |
|-------------------------------------------|-----------|
| • Safety Glasses for Each Person | 1 |
| • Mounting Hardware | As Needed |
| • Wrench or Socket 13mm | 1 |
| • Hex Wrench 1.5mm | 1 |
| • Phillips Head Screwdriver #2 | 1 |
| • Disposable Gloves for Cleaning | As Needed |
| • Degreaser or Solvent for Cleaning | As Needed |
| • Paint Brush for Cleaning | 1 |
| • Disposable Rags for Cleaning | As Needed |
| • Plumb Bob | 1 |
| • Ruler | 1 |
| • Block of Wood (At Least 4" x 4") | 1 |
| • Assistant for Lifting | 1 |

SETUP



⚠ WARNING

This machine presents serious injury hazards to untrained users. Read through this entire manual to become familiar with the controls and operations before starting the machine!



⚠ WARNING

Wear safety glasses during entire setup process!



⚠ WARNING

USE helpers or power lifting equipment to lift this machine. Otherwise, serious personal injury may occur.

⚠ WARNING

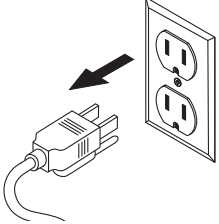

Keep machine disconnected from power until instructed otherwise.

Inventory

The following is a list of items shipped with your machine. Before beginning setup, lay these items out and inventory them.

Note: If you cannot find an item on this list, carefully check around/inside the machine and packaging materials. Often, these items get lost in packaging materials while unpacking or they are pre-installed at the factory.

| Box Inventory (Figure 4) | Qty | |
|-----------------------------------|-----|-------------------------------------------|
| A. Table Bracket Assembly..... | 1 | N. Downfeed Levers |
| B. Headstock Assembly..... | 1 | O. Table..... |
| C. Base..... | 1 | P. Hex Wrenches 3, 5mm..... |
| D. Special Wrench 24mm | 1 | Q. Table Support Arm Bracket (W1670)..... |
| E. Rack (W1670)..... | 1 | R. Column (W1670) |
| F. Column Ring (W1669) | 1 | S. Hardware and Tools (Not Shown) |
| G. Column (W1669) | 1 | –Hex Bolt M8-1.25 x 20 |
| H. Hex Bolts M8-1.25 x 125..... | 4 | –Flat Washers 8mm..... |
| –Wing Nuts M8-1.25 | 4 | –Phillips Head Screws M4-.7 x 10 |
| –Flat Washers 8mm..... | 8 | –Flat Washers 4mm..... |
| I. Locking Gib | 1 | –Lock Washers 4mm |
| J. Chuck Key..... | 1 | –Belts Cover Knob |
| K. Drill Chuck..... | 1 | –Tap Screw #8 x 3/4" |
| L. Lock Levers M10-1.5 x 30 | 2 | –Chuck Guard Assembly..... |
| M. Lift Handle Crank..... | 1 | |

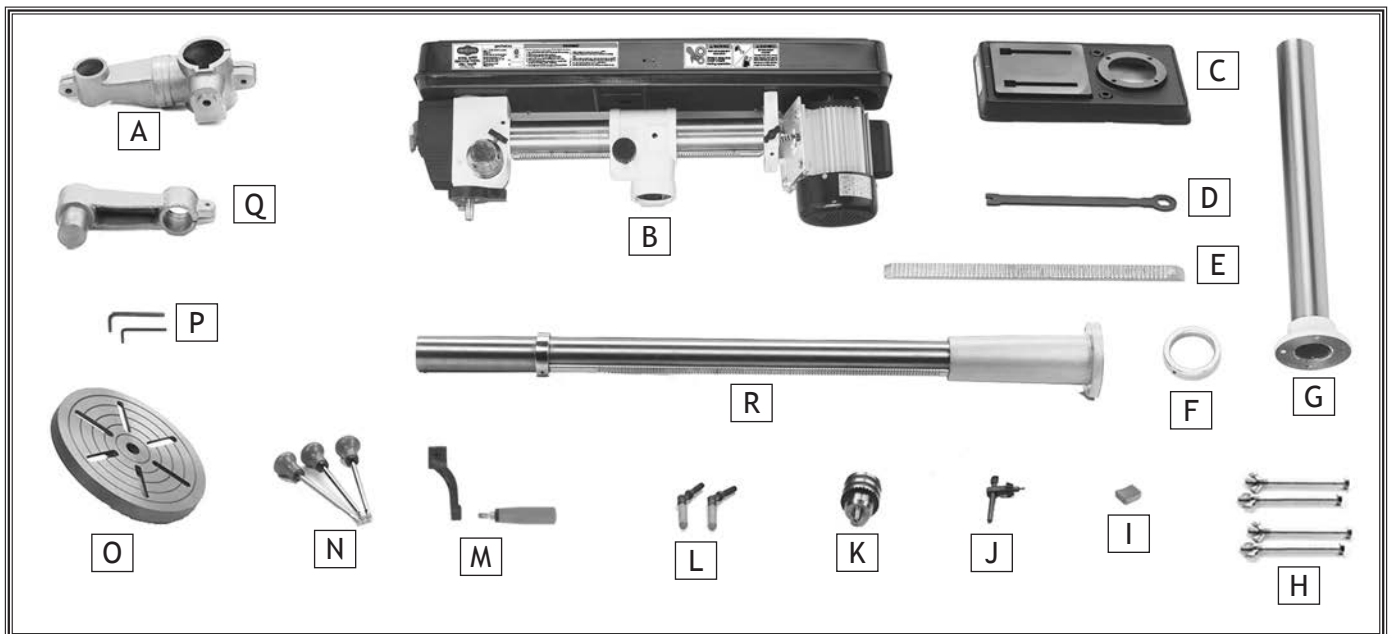

Figure 4. W1669 and W1670 inventory.

SETUP

Cleaning Machine

To prevent corrosion during shipment and storage of your machine, the factory has coated the bare metal surfaces of your machine with a heavy-duty rust prevention compound.

If you are unprepared or impatient, this compound can be difficult to remove. To ensure that the removal of this coating is as easy as possible, please gather the correct cleaner, lubricant, and tools listed below:

- Cleaner/degreaser designed to remove storage wax and grease
- Safety glasses & disposable gloves
- Solvent brush or paint brush
- Disposable Rags

To remove rust preventative coating, do these steps:

1. DISCONNECT MACHINE FROM POWER!
2. Put on safety glasses and disposable gloves.
3. Coat the rust preventative with a liberal amount of cleaner/degreaser, then let it soak for 5-10 minutes.
4. Wipe off surfaces. If your cleaner/degreaser is effective, the coating will wipe off easily.

Tip: *An easier way to clean off thick coats of rust preventative from flat surfaces is to use a PLASTIC paint scraper to scrape off the majority of the coating before wiping it off with your rag. (Do not use a metal scraper or you may scratch your machine.)*

5. Repeat cleaning steps as necessary until all of the compound is removed.
6. To prevent rust on freshly cleaned surfaces, immediately coat with a quality metal protectant.

! WARNING

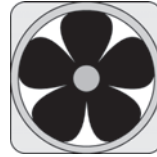

Gasoline and petroleum products have low flash points and can explode or cause fire if used to clean machinery. Avoid using these products to clean machinery. Many cleaning solvents are toxic if inhaled. Minimize your risk by only using these products in a well ventilated area.

NOTICE

In a pinch, automotive degreasers, mineral spirits or WD•40 can be used to remove rust preventative coating. Before using these products, though, test them on an inconspicuous area of your paint to make sure they will not damage it.

Machine Placement

Weight Load

Refer to the **Machine Specifications** for the weight of your machine. Make sure that the surface upon which the machine is placed will bear the weight of the machine, additional equipment that may be installed on the machine, and the heaviest workpiece that will be used. Additionally, consider the weight of the operator and any dynamic loading that may occur when operating the machine.

Space Allocation

Consider the largest size of workpiece that will be processed through this machine and provide enough space around the machine for adequate operator material handling or the installation of auxiliary equipment. With permanent installations, leave enough space around the machine to open or remove doors/covers as required by the maintenance and service described in this manual. **See below for required space allocation.**

Physical Environment

The physical environment where your machine is operated is important for safe operation and the longevity of its components. For best results, operate this machine in a dry environment that is free from excessive moisture, hazardous chemicals, airborne abrasives, or extreme conditions. Extreme conditions for this type of machinery are generally those where the ambient temperature range exceeds 41°-104°F; the relative humidity range exceeds 20-95% (non-condensing); or the environment is subject to vibration, shocks, or bumps.

Electrical Installation

Place this machine near an existing power source. Make sure all power cords are protected from traffic, material handling, moisture, chemicals, or other hazards. Make sure to leave access to a means of disconnecting the power source or engaging a lockout/tagout device.

Lighting

Lighting around the machine must be adequate enough that operations can be performed safely. Shadows, glare, or strobe effects that may distract or impede the operator must be eliminated.

SETUP

| | |
|-------------------------------------------------------------------------------------|------------------------------------------------------------------------------------------------------------------------------------------------------|
|  | <p>⚠ CAUTION</p> <p>Children or untrained people may be seriously injured by this machine. Only install in an access restricted location.</p> |
|-------------------------------------------------------------------------------------|------------------------------------------------------------------------------------------------------------------------------------------------------|

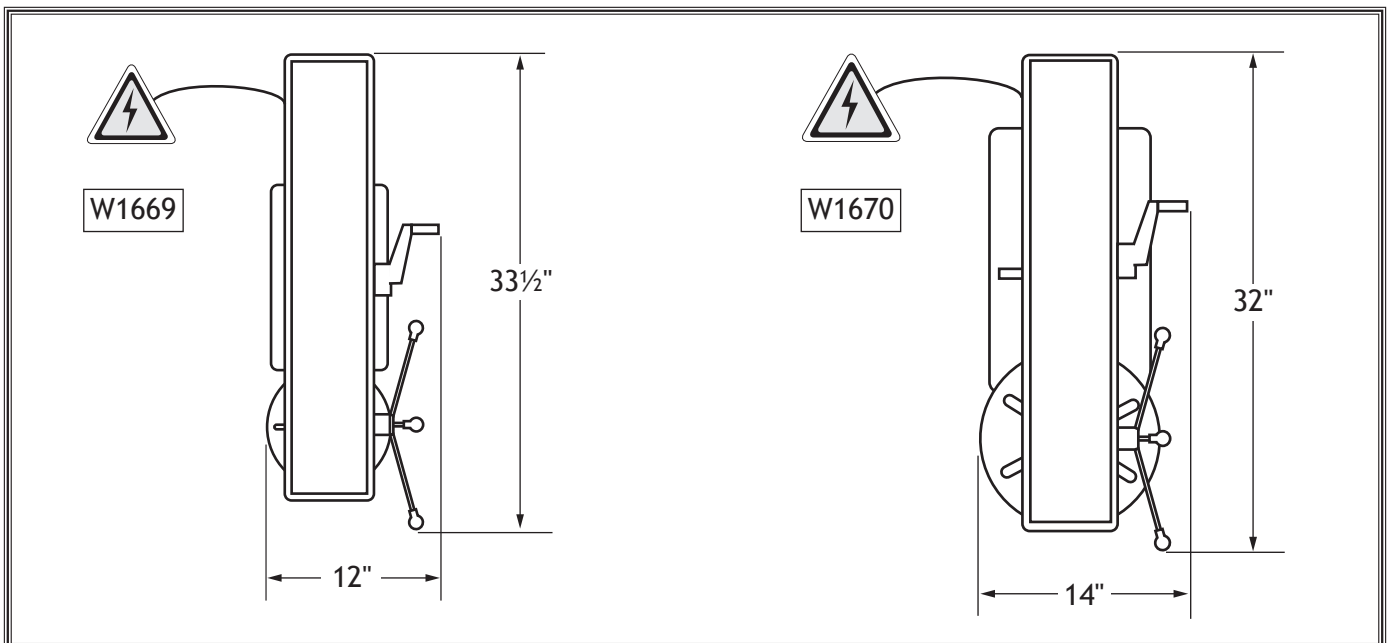

Figure 5. Working clearances.

Mounting to Bench (W1669)

Number of Mounting Holes..... 4
Hex Bolts size included..... M8-1.25 x 125

The base of this machine has mounting holes that allow it to be fastened to a workbench or other mounting surface to prevent it from moving during operation and causing accidental injury or damage.

The strongest mounting option is a “Through Mount” (see example) where holes are drilled all the way through the workbench—and hex bolts, washers, and hex nuts are used to secure the machine in place.

Another option is a “Direct Mount” (see example) where the machine is secured directly to the workbench with lag screws and washers.

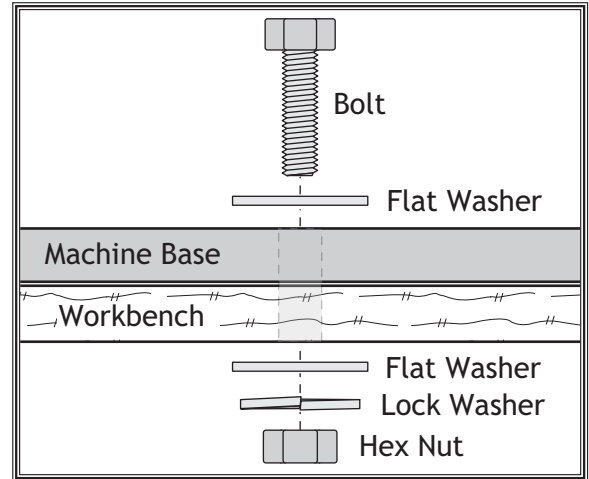

Figure 6. Typical "Through Mount" setup.

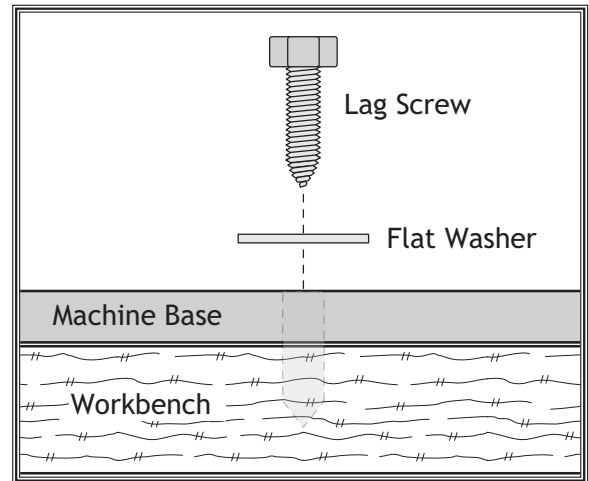

Figure 7. Typical "Direct Mount" setup.

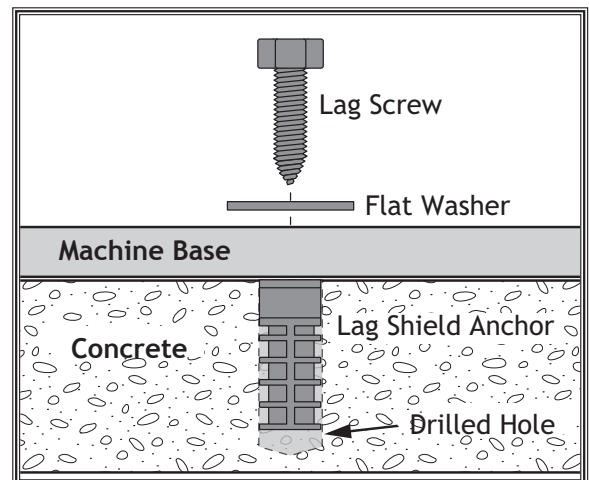

Figure 8. Popular method for anchoring machinery to a concrete floor.

Anchoring to Floor (W1670)

Number of Mounting Holes..... 4
Diameter of Mounting Hardware 5/16"

Anchoring machinery to the floor prevents tipping or shifting and reduces vibration that may occur during operation, resulting in a machine that runs slightly quieter and feels more solid.

If the machine will be installed in a commercial or workplace setting, or if it is permanently connected (hardwired) to the power supply, local codes may require that it be anchored to the floor.

If not required by any local codes, fastening the machine to the floor is an optional step. If you choose not to do this with your machine, we recommend placing it on machine mounts, as these provide an easy method for leveling and they have vibration-absorbing pads.

Anchoring to Concrete Floors

Lag shield anchors with lag screws (see Figure) are a popular way to anchor machinery to a concrete floor, because the anchors sit flush with the floor surface, making it easy to unbolt and move the machine later, if needed. However, anytime local codes apply, you **MUST** follow the anchoring methodology specified by the code.

Mounting W1670 to Mobile Base

Because the drill press is top-heavy by nature, we recommend mounting it to the floor, rather than a mobile base.

If you must use a mobile base, ALWAYS mount your drill press to a base plate inside of the mobile base, as shown in Figure 9.

A good quality base plate increases the standard footprint of the drill press to make it much more stable. The base plate must be at least 1 1/2" thick and made of plywood (do not use OSB, MDF, or particle board) to hold the weight of the drill press. A common way for making the baseplate is described in this sub-section.

Always use extreme care when moving the drill press around with the mobile base!

Items Needed

| | Qty |
|----------------------------------------------------|-----------|
| Plywood 3/4" x 23 3/4" x 23 3/4" | 2 |
| Wood Glue | As Needed |
| Wood Screws #6 x 1 1/4" | 24 |
| Hex Bolts (2 1/4" Long, Sized for Base Plate)..... | 4 |
| Hex Nuts (Sized for Hex Bolts) | 4 |
| Lock Washers (Sized for Hex Bolts)..... | 4 |
| Flat Washers (Sized for Hex Bolts)..... | 8 |
| Assistant to Lift Drill Press | 1 |

To make and use the base plate, do these steps:

1. Glue the two pieces of plywood together, aligning edges and corners to make one thick piece.
2. Use wood screws to secure boards together from both sides.
3. Allow 24 hours for glue to dry before mounting drill press.
4. Place plywood base plate on mobile base.
5. Drill holes through base plate and metal plates at mobile base corners.
6. Secure base plate to mobile base with hex bolts, hex nuts, flat washers and lock washers, as shown in Figure 10.

⚠ CAUTION

Drill presses are top-heavy and must be securely attached to a large-footprint base plate when used with a mobile base. Failure to use a base plate greatly increases possibility of tipping and personal injury.

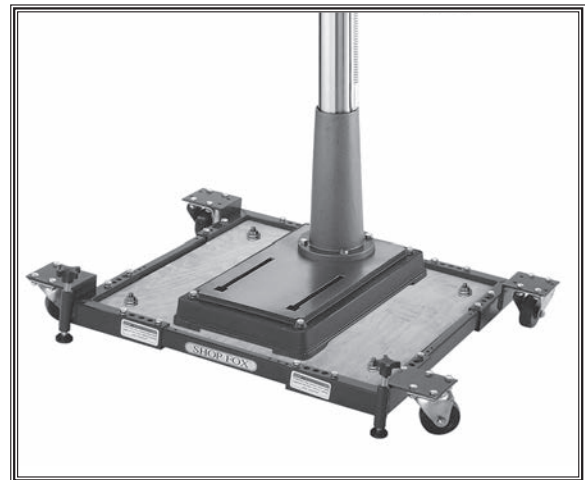

Figure 9. Drill press mounted on mobile base, using a base plate for support.

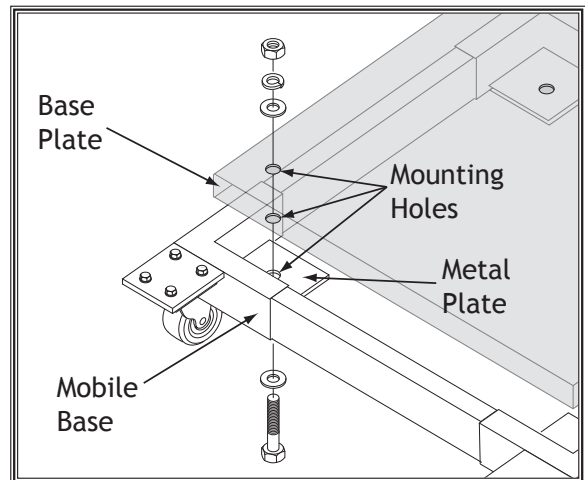

Figure 10. Mounting base plate to mobile base.

SETUP

Assembly

Before beginning the assembly process, refer to **Items Needed for Setup** and gather everything you need. Ensure all parts have been properly cleaned of any heavy-duty rust-preventative applied at the factory (if applicable). Be sure to complete all steps in the assembly procedure prior to performing the **Test Run**.

The W1669 comes with one geared table bracket. The W1670 comes with a geared table bracket and a table support arm, which allows the distance between the column and table to be adjusted. The table bracket and support parts are not interchangeable between models.

To assemble the drill press, do these steps:

1. Place the column on the base and align the mounting holes.
2. Secure the column to the base with the (4) M8-1.25 x 20 hex bolts and 8mm flat washers, as shown in **Figure 11**.
3. Align the set screw in the crank handle with the flat pad on pinion shaft of the table bracket assembly (see **Figure 12**).
4. Tighten the 3mm set screw to lock the handle in place.
5. Examine the rack and note that the rack teeth at one end are cut closer to the end of the rack than the other.
6. Insert the rack through the table bracket so the end that has the rack teeth cut closer to the end is pointing down (see **Figure 13**).
7. Hold the rack against the worm gear and slide the table bracket and rack onto the column (see **Figure 13**).



Figure 11. Column secured to base.

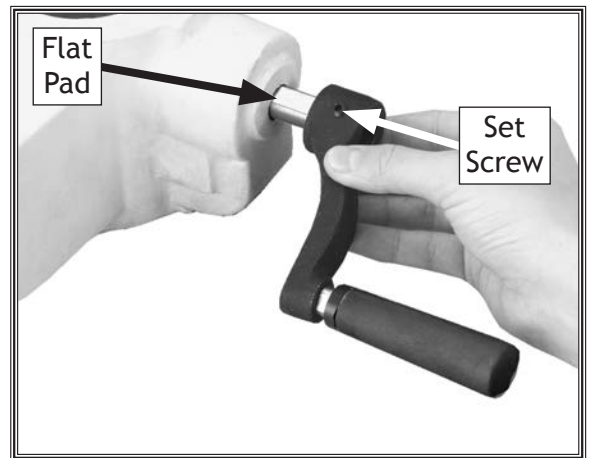

Figure 12. Aligning set screw with flat pad on pinion.

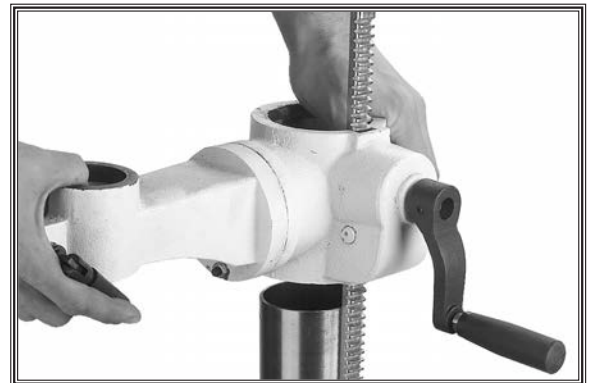

Figure 13. Installing rack and table bracket.

- 8. Seat the rack tapered point into the bevel that is cut into the column support tube (see Figure 14).



Figure 14. Bevel and rack seated correctly.

- 9. Slide the column ring onto the column with the inside bevel in the down position until the rack tapered-point seats into the bevel (see Figure 15).
- 10. Position the column ring so the table bracket and rack can just rotate around the column without binding.
- 11. Carefully snug the set screw to hold the column ring in place. DO NOT overtighten the set screw to avoid distorting the column or splitting the column ring.

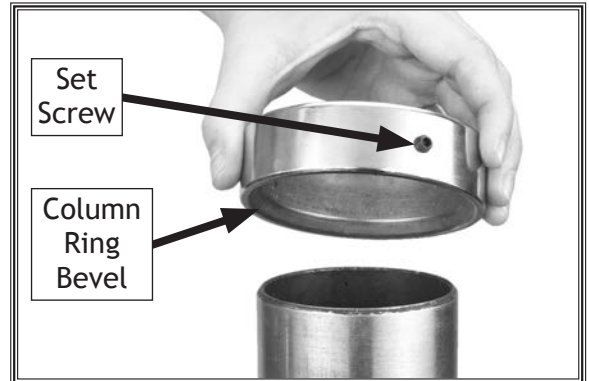

Figure 15. Column ring in correct position.

- 12. **W1669 Only:** Install table onto the table bracket and tighten table rotation lock lever to secure (see Figure 16).

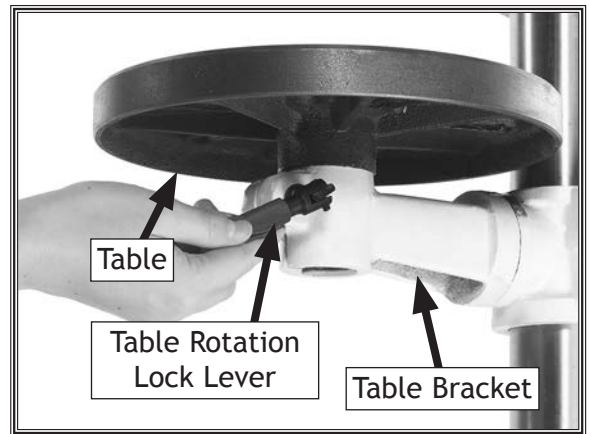

Figure 16. Model W1669 table assembly.

- 13. **W1670 Only:** Install the table support arm bracket onto the table bracket, then install the table and tighten lock levers to secure (see Figure 17).

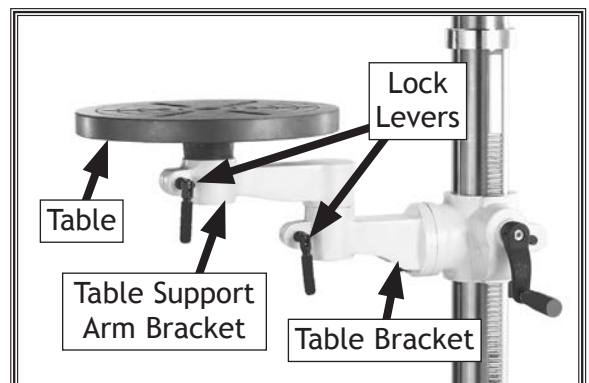

Figure 17. Model W1670 table assembly.

SETUP

- Place the locking gib into the recessed pocket on the inside of the column bracket casting (see Figure 18).

| | |
|--|-------------------------------------------------------------------------------------------------------------------------|
| | <p>CAUTION</p> <p>Get help to lift the headstock, or you may seriously hurt your back or drop the headstock.</p> |
|--|-------------------------------------------------------------------------------------------------------------------------|

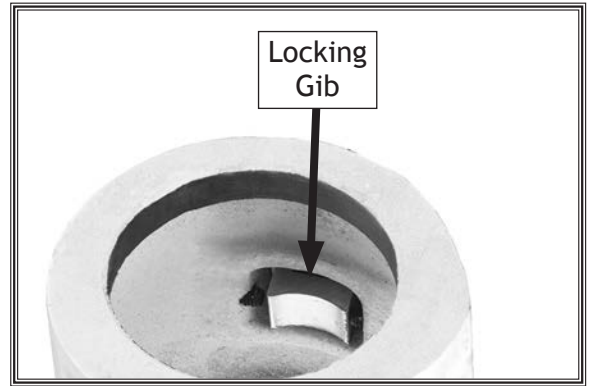

Figure 18. Locking gib location.

- With an assistant, lift and position the headstock pocket over the column and allow the headstock to slide down until the column fully seats into the headstock (approximately 2", see Figure 19).
- Rotate the headstock directly over the foot of the base as viewed from the front of the drill press.



Figure 19. Installing the headstock onto the column.

- Thread the downfeed handles into the hub, as shown in Figure 20.
- Attach the belts cover knob to the belts cover with (1) #8 x 3/4" tap screw, (see Figure 20).

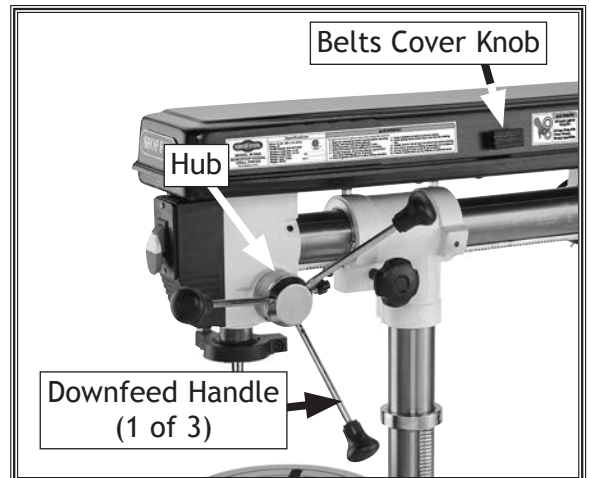

Figure 20. Downfeed handles thread into hub and belts cover installed.

SETUP

19. Rotate the table out of the way, then use a plumb bob and ruler to center the headstock with the base (see **Figure 21**).
20. Screw in the two lock handles on the sides of the headstock to secure.



Figure 21. Aligning the headstock.

21. Slide chuck guard onto bottom of depth stop bracket, as shown in **Figure 22**.



Figure 22. Chuck guard installed on depth stop bracket.

22. Secure chuck guard to bracket with (4) M4-.7 x 10 Phillips head screws, 4mm lock washers, and 4mm flat washers, as shown in **Figure 23**.

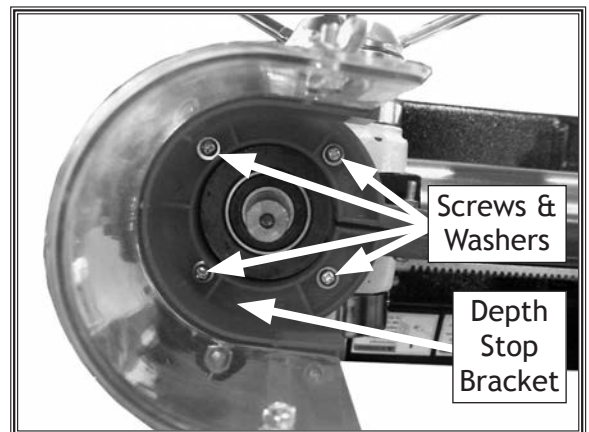

Figure 23. Chuck guard secured to depth stop bracket.

SETUP

Joining Drill Chuck & Arbor

An arbor is included for the drill chuck that comes with this machine. The following procedure describes how to install the arbor in the chuck.

After the arbor is installed in the drill chuck, it is very difficult to separate the assembly. If you would like to use a different chuck in the future, we recommend obtaining a new arbor.

Important: *DO NOT* install the drill chuck and arbor assembly into the spindle until *AFTER* the test run.

To join drill chuck and arbor, do these steps:

1. Use acetone or lacquer thinner to clean drill chuck and arbor mating surfaces, especially the bore.
2. Retract chuck jaws completely into chuck.
3. Insert small end of arbor into chuck.
4. Hold assembly by the arbor and tap chuck onto a block of wood with medium force, as illustrated.
5. Attempt to separate the drill chuck and arbor by hand—if they separate, repeat **Steps 3–5**.

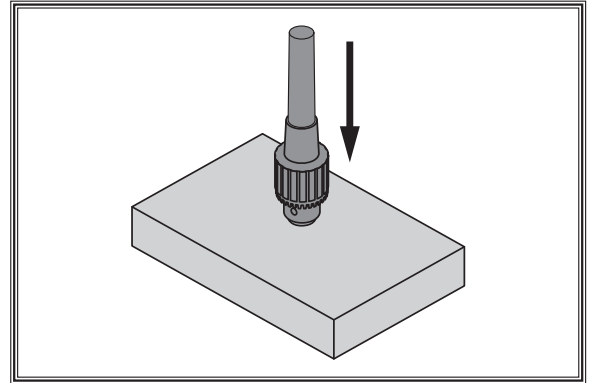

Figure 24. Joining drill chuck to arbor.

Test Run

Once assembly is complete, test run the machine to ensure it is properly connected to power and safety components are functioning properly.

If you find an unusual problem during the test run, immediately stop the machine, disconnect it from power, and fix the problem **BEFORE** operating the machine again. The **Troubleshooting** table in the **SERVICE** section of this manual can help.

The Test Run consists of verifying the following: 1) The motor powers up and runs correctly, and 2) the safety disabling mechanism on the switch works correctly.

To test run the machine, do these steps:

1. Clear all setup tools away from machine.
2. Connect machine to power supply.
3. Turn machine **ON**, verify motor operation, then turn machine **OFF**.

The motor should run smoothly and without unusual noises.

4. Remove switch disabling key (see example).
5. Try to start machine with paddle switch. The machine should not start.
 - If machine *does not* start, the switch disabling feature is working as designed.
 - If machine *does* start, immediately stop the machine. The switch disabling feature is not working correctly. This safety feature must work properly before proceeding with regular operations. Call Tech Support for help.

WARNING

Serious injury or death can result from using this machine **BEFORE** understanding its controls and related safety information. **DO NOT** operate, or allow others to operate, machine until the information is understood.

WARNING

DO NOT start machine until all preceding setup instructions have been performed. Operating an improperly set up machine may result in malfunction or unexpected results that can lead to serious injury, death, or machine/property damage.

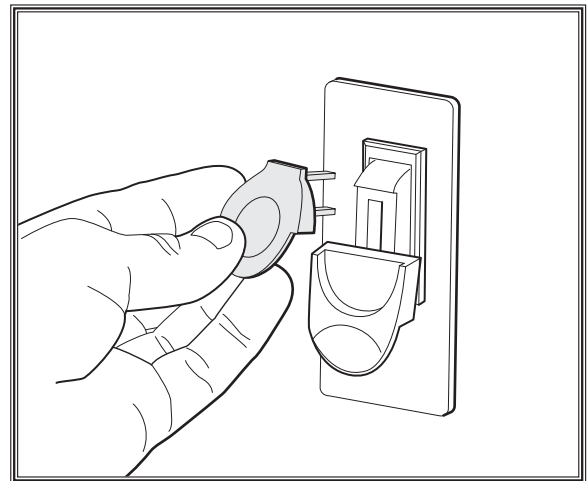

Figure 25. Removing switch key from power switch.

OPERATIONS

General

This machine will perform many types of operations that are beyond the scope of this manual. Many of these operations can be dangerous or deadly if performed incorrectly.

The instructions in this section are written with the understanding that the operator has the necessary knowledge and skills to operate this machine. If at any time you are experiencing difficulties performing any operation, stop using the machine!

The overview below provides the novice machine operator with a basic understanding of how the machine is used during operation, so the machine controls/components discussed later in this manual are easier to understand. Due to its generic nature, this overview is **NOT** intended to be an instructional guide.

To complete typical operation, operator does following:

1. Examines workpiece to make sure it is suitable for drilling.
2. Puts on required safety glasses and face shield.
3. Firmly secures workpiece to table using a vise or T-slot clamps.
4. Installs correct cutting tool for operation.
5. Adjusts table to correct height, then locks it in place.
6. Selects appropriate spindle speed according to V-belt configuration chart located inside belt cover.
7. Connects machine to power, and starts spindle rotation in proper direction for cutting tool installed.
8. Begins drilling.
9. When finished, stops spindle rotation and disconnects machine from power.

WARNING



To reduce your risk of serious injury or damage to the machine, read this entire manual **BEFORE** using machine.

WARNING

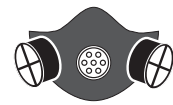

To reduce the risk of eye injury and long-term respiratory damage, always wear safety glasses and a respirator while operating this machine.

NOTICE

If you are an inexperienced operator, we strongly recommend that you read books or trade articles, or seek training from an experienced operator of this type of machinery before performing unfamiliar operations. Above all, safety must come first!

Drill Press RPM Chart

Use **Figure 26** to select the optimum motor-to-spindle pulley ratio for drilling, cutting, and sanding operations. For example the above figure shows the belt in the C position on the spindle pulley and the #3 position on the motor pulley, which will give a speed of 1610 RPM. Refer to the **Drill, Cutter, and Hole Saw Suggested RPM Chart** on **Page 28** for suggested tool RPMs.

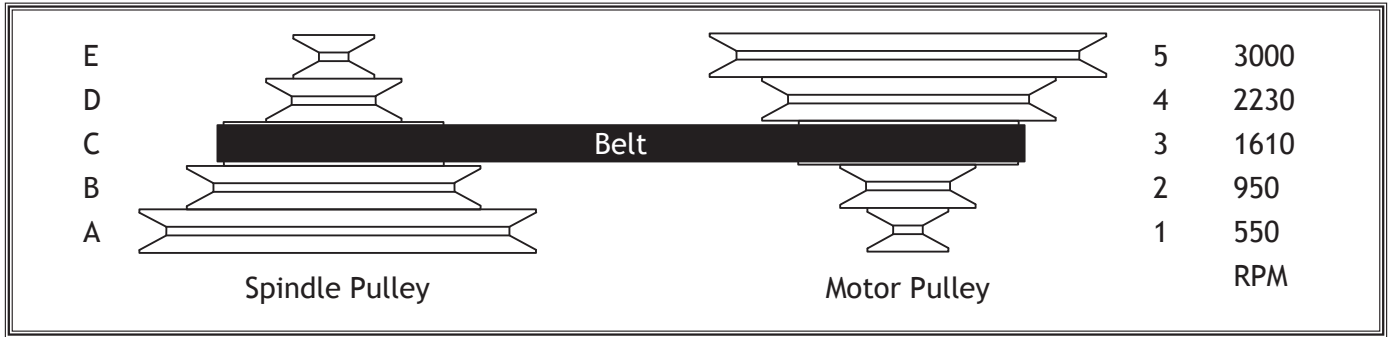

Figure 26. Drill Press RPM Chart.

Lubrication Suggestions

- Wood/Cast Iron..... None
- Plastics Soapy Water
- Brass Water-Based Lubricant
- Aluminum Paraffin-Based Lubricant
- Mild Steel Oil-Based Lubricant

Drill, Cutter, & Hole Saw Suggested RPM Chart

ALWAYS follow the drill, saw, or cutter manufacturer's recommended RPM specifications. ALWAYS wear safety glasses. DO NOT use your drill press to exceed the drilling, cutting, or sawing RPM or the feed rate of your bit or cutter. Otherwise serious personal injury can occur.

The RPMs listed below are merely suggestions to help you use your drill press in the event that you cannot find a basic starting RPM point. The final RPMs may differ based on the material drilled, the pressure you apply, and the cut-quality needed. Remember, even if the RPM and all other settings are correct, cooling the tool with a lubricant and drilling a pilot hole may also be required. Refer to WARNINGS and TIPS, trade journals, training manuals, and other educational resources for in-depth instructions and safety knowledge.

For current product line, refer to: <http://www.woodstockint.com>.

| Sanding Sleeves or Grinding Bits | Soft Wood | Hard Wood | Plastic | Brass | Aluminum | Mild Steel |
|---------------------------------------------------------------|-----------|-----------|---------|-------|----------|------------|
| 1", 1-1/2", 2" | 2000 | 1725 | 1000 | 3100 | 3100 | 3100 |
| Twist Type Drill Bits: (Wood, Plastic, and Metal) | | | | | | |
| 1/16" to 3/16" | 3000 | 3000 | 2500 | 3000 | 3000 | 3000 |
| 1/4" to 3/8" | 3000 | 1500 | 2000 | 1200 | 2500 | 1000 |
| 7/16" to 5/8" | 1500 | 750 | 1500 | 750 | 1500 | 600 |
| 11/16" to 1" | 750 | 500 | - | 400 | 1000 | 350 |
| Spade Drill Bits: (Wood) | | | | | | |
| 1/4" to 1/2" | 2000 | 1500 | - | - | - | - |
| 5/8" to 1" | 1750 | 1500 | - | - | - | - |
| 1-1/8" to 1-1/2" | 1500 | 1000 | - | - | - | - |
| Spade with Spur Drill Bits: (Wood and Plastic) | | | | | | |
| 3/8" to 1" | 2000 | 1800 | 500 | - | - | - |
| Brad Point Drill Bits: (Wood and Plastic) | | | | | | |
| 1/8" | 1800 | 1200 | 1500 | - | - | - |
| 1/4" | 1800 | 1000 | 1500 | - | - | - |
| 3/8" | 1800 | 750 | 1500 | - | - | - |
| 1/2" | 1800 | 750 | 1000 | - | - | - |
| 5/8" | 1800 | 500 | 750 | - | - | - |
| 3/4" | 1400 | 250 | 750 | - | - | - |
| 7/8" | 1200 | 250 | 500 | - | - | - |
| 1" | 1000 | 250 | 250 | - | - | - |
| Forstner Drill Bits: (Wood and Plastic) | | | | | | |
| 1/4" to 11/16" | 2400 | 1600 | 250 | - | - | - |
| 3/4" to 1-1/16" | 1800 | 1200 | 250 | - | - | - |
| 1-1/8" to 1-7/16" | 1200 | 800 | 250 | - | - | - |
| 1-1/2" to 2-1/8" | 600 | 450 | - | - | - | - |
| 2-1/4" to 3-1/8" | 480 | 250 | - | - | - | - |
| Multi-Spur Drill Bits: (Wood) | | | | | | |
| 2-1/8" to 4" | 250 | 250 | - | - | - | - |
| Countersink Cutters: (Wood, Plastic, and Metal) | | | | | | |
| 2-Flute Cutter | 1400 | 1400 | - | - | - | - |
| 5-Flute Cutter | 1000 | 750 | 750 | 250 | 250 | 250 |
| Plug Cutters: (Wood) | | | | | | |
| 3/8" to 1/2" | 1200 | 1000 | - | - | - | - |
| 5/8" to 1" | 800 | 600 | - | - | - | - |
| Carbide Rosette Cutters: One-Piece Shear Type (Wood) | | | | | | |
| 2-1/2" to 3" | 1800 | 500 | - | - | - | - |
| Rosette Cutters: Replaceable Carbide-Knife Type (Wood) | | | | | | |
| 2-1/4" to 3-1/8" | 350 | 250 | - | - | - | - |

WARNINGS and TIPS

- **WARNING:** The larger the drill bit or hole saw and the slower the RPM, the greater the chance the tool could aggressively grab the workpiece, damage the tool and workpiece and cause injury. High RPMs can melt plastic, burn wood, and dull the tool.
- **WARNING:** Use a 5-Flute cutter when cutting into plastics, brass, aluminum, and mild steel. A 2-Flute cutter can aggressively grab the workpiece and damage the tool.
- **TIP:** To increase the life of drill bits, cutters, hole saws, and improve cut quality, use a lubricant equivalent to these:
 - Plastics:** use a soapy-water lubricant
 - Brass:** use a water-based lubricant
 - Mild Steel:** use an oil-based lubricant
 - Aluminum:** use a paraffin-based lubricant
 - Cast Iron:** use a pipe-thread cutting lubricant
 - Wood:** use no lubricant.
- **TIP:** Raise the drill bit, cutter, or hole saw often to clear chips and cool the tool.
- **TIP:** When drilling plastics with spade bits, use a spade bit with spurs.
- **TIP:** Plug cutters and rosette cutters are for wood only; however, carbide-tipped bits and cutters cut at a higher RPM, and can cut materials other than wood depending on cutter type. Carbide makes better cuts and lasts longer than HSS steel.
- **TIP:** When using hole saws, apply firm and even pressure, so the saw teeth contact the surface all at the same time-not at an angle. You can also flip the workpiece and finish drilling from the other side.
- **TIP:** To prevent drill bit wandering, use a center punch to start the drill bit.

OPERATIONS



| Saws: Bi-Metal Hole Saws (Most Materials) | | | | | | | | | | | | | | | |
|-------------------------------------------|-----------|-----------|---------|------------|-----------|-------|----------|-------------------|-----------|-----------|---------|------------|-----------|-------|----------|
| Hole Saw Diameter | Soft Wood | Hard Wood | Plastic | Mild Steel | Cast Iron | Brass | Aluminum | Hole Saw Diameter | Soft Wood | Hard Wood | Plastic | Mild Steel | Cast Iron | Brass | Aluminum |
| 9/16" | 1150 | 870 | 1320 | 580 | 400 | 790 | 900 | 2-7/8" | 240 | 180 | 275 | 120 | 80 | 160 | 180 |
| 5/8" | 1100 | 825 | 1250 | 550 | 365 | 730 | 825 | 3" | 230 | 170 | 260 | 115 | 75 | 150 | 170 |
| 11/16" | 1000 | 750 | 1140 | 500 | 330 | 665 | 750 | 3-1/16" | 220 | 165 | 250 | 110 | 75 | 150 | 170 |
| 3/4" | 920 | 690 | 1050 | 460 | 300 | 600 | 690 | 3-1/8" | 220 | 165 | 250 | 110 | 70 | 140 | 165 |
| 13/16" | 850 | 635 | 970 | 425 | 280 | 560 | 635 | 3-3/16" | 210 | 155 | 240 | 105 | 70 | 140 | 165 |
| 7/8" | 780 | 585 | 890 | 390 | 260 | 520 | 585 | 3-1/4" | 210 | 155 | 240 | 105 | 70 | 140 | 155 |
| 15/16" | 740 | 555 | 845 | 370 | 245 | 495 | 555 | 3-5/16" | 200 | 150 | 225 | 100 | 70 | 130 | 155 |
| 1" | 700 | 525 | 800 | 350 | 235 | 470 | 525 | 3-3/8" | 200 | 150 | 225 | 100 | 65 | 130 | 150 |
| 1-1/16" | 650 | 480 | 740 | 325 | 215 | 435 | 480 | 3-7/16" | 200 | 150 | 225 | 100 | 65 | 130 | 150 |
| 1-1/8" | 600 | 450 | 685 | 300 | 200 | 400 | 450 | 3-1/2" | 190 | 140 | 215 | 95 | 65 | 130 | 145 |
| 1-3/16" | 570 | 430 | 650 | 285 | 190 | 380 | 425 | 3-9/16" | 190 | 140 | 215 | 95 | 65 | 120 | 145 |
| 1-1/4" | 550 | 410 | 625 | 275 | 180 | 360 | 410 | 3-5/8" | 190 | 140 | 215 | 95 | 60 | 120 | 140 |
| 1-5/16" | 520 | 390 | 595 | 260 | 175 | 345 | 390 | 3-11/16" | 180 | 135 | 205 | 90 | 60 | 120 | 140 |
| 1-3/8" | 500 | 375 | 570 | 250 | 165 | 330 | 375 | 3-3/4" | 180 | 135 | 205 | 90 | 60 | 120 | 135 |
| 1-7/16" | 480 | 360 | 545 | 240 | 160 | 315 | 360 | 3-13/16" | 180 | 135 | 205 | 90 | 60 | 120 | 135 |
| 1-1/2" | 460 | 345 | 525 | 230 | 150 | 300 | 345 | 3-7/8" | 180 | 135 | 205 | 90 | 60 | 120 | 135 |
| 1-9/16" | 440 | 330 | 500 | 220 | 145 | 290 | 330 | 4" | 170 | 130 | 195 | 85 | 55 | 110 | 130 |
| 1-5/8" | 420 | 315 | 475 | 210 | 140 | 280 | 315 | 4-1/16" | 170 | 130 | 195 | 85 | 55 | 110 | 120 |
| 1-11/16" | 410 | 310 | 465 | 205 | 130 | 260 | 295 | 4-1/8" | 160 | 120 | 180 | 80 | 55 | 110 | 120 |
| 1-3/4" | 390 | 290 | 445 | 195 | 130 | 260 | 295 | 4-3/16" | 160 | 120 | 180 | 80 | 55 | 110 | 120 |
| 1-13/16" | 380 | 285 | 435 | 190 | 125 | 250 | 285 | 4-1/4" | 160 | 120 | 180 | 80 | 55 | 100 | 120 |
| 1-7/8" | 360 | 270 | 400 | 180 | 120 | 240 | 270 | 4-5/16" | 160 | 120 | 180 | 80 | 55 | 100 | 120 |
| 2" | 340 | 255 | 385 | 170 | 115 | 230 | 255 | 4-3/8" | 160 | 120 | 180 | 80 | 50 | 100 | 120 |
| 2-1/16" | 330 | 245 | 375 | 165 | 110 | 220 | 245 | 4-7/16" | 150 | 110 | 170 | 75 | 50 | 100 | 105 |
| 2-1/8" | 320 | 240 | 365 | 160 | 105 | 210 | 240 | 4-1/2" | 150 | 110 | 170 | 75 | 50 | 100 | 105 |
| 2-3/16" | 310 | 230 | 355 | 155 | 105 | 205 | 240 | 4-9/16" | 150 | 110 | 170 | 75 | 50 | 95 | 100 |
| 2-1/4" | 300 | 225 | 340 | 150 | 100 | 200 | 225 | 4-5/8" | 150 | 110 | 170 | 75 | 50 | 95 | 100 |
| 2-5/16" | 290 | 215 | 330 | 145 | 100 | 195 | 225 | 4-11/16" | 150 | 110 | 170 | 75 | 50 | 95 | 100 |
| 2-3/8" | 280 | 210 | 320 | 140 | 95 | 190 | 220 | 4-3/4" | 150 | 110 | 170 | 75 | 50 | 95 | 95 |
| 2-7/16" | 280 | 210 | 320 | 140 | 95 | 185 | 210 | 4-13/16" | 130 | 100 | 150 | 65 | 45 | 90 | 95 |
| 2-1/2" | 270 | 200 | 310 | 135 | 90 | 180 | 205 | 4-7/8" | 130 | 100 | 150 | 65 | 45 | 90 | 90 |
| 2-9/16" | 270 | 200 | 310 | 135 | 85 | 175 | 200 | 5" | 130 | 100 | 150 | 65 | 45 | 90 | 90 |
| 2-5/8" | 260 | 195 | 295 | 130 | 85 | 170 | 195 | 5-1/4" | 120 | 90 | 135 | 60 | 40 | 85 | 85 |
| 2-11/16" | 260 | 195 | 295 | 130 | 85 | 165 | 190 | 5-1/2" | 120 | 90 | 135 | 60 | 40 | 85 | 85 |
| 2-3/4" | 250 | 185 | 285 | 125 | 80 | 160 | 185 | 5-3/4" | 110 | 80 | 125 | 55 | 35 | 75 | 75 |
| 2-13/16" | 250 | 185 | 285 | 125 | 80 | 160 | 185 | 6" | 110 | 80 | 125 | 55 | 35 | 75 | 75 |

Changing Speeds

The Model W1669 and W1670 Radial Drill Press has 5 speeds ranging from 550 to 3000 RPM. To find your needed drilling speed and pulley combination, refer to the speed chart located under the belt guard; or refer to the Drill Press RPM Chart on Page 27.

To change the drilling speed, do these steps:

1. DISCONNECT MACHINE FROM POWER!
2. Loosen the belt tension lock knobs on both sides of the headstock (see Figure 27), so the motor is free to move.

⚠ WARNING

Unplug the drill press before changing speeds to avoid accidental startup. Failure to do this may result in serious personal injury.

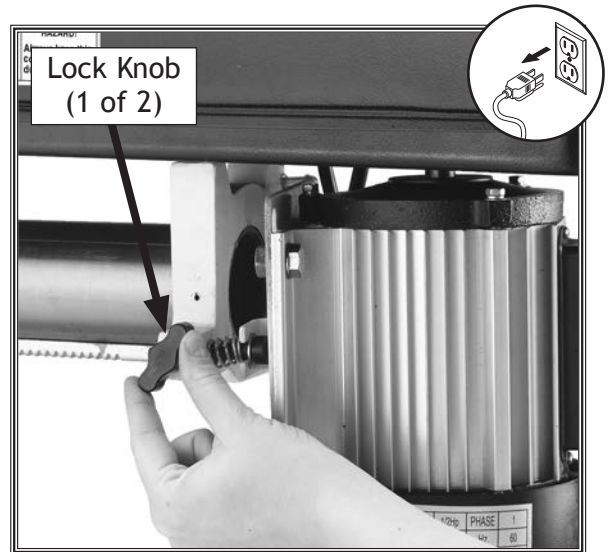

Figure 27. Loosening lock knob.

⚠ WARNING

Never operate drill press with belt cover in the open position. Your hand may become trapped in a belt and serious personal injury will occur.

3. Locate the desired speed on the speed chart under the pulley cover, and move the V-belt to the desired V-grooves on the motor and spindle pulleys (see Figure 28).
4. Pivot the motor toward the back of the headstock and tighten the lock knobs once the desired V-belt tension is achieved.
5. Close the cover before connecting the machine to power.



Figure 28. Belt set to desired speed.

Drilling

The Model W1669/W1670 is designed for drilling holes in wood, plastic, and metal. The basic operation of a drill press is lining up your drill bit with the intended hole location, turning the drill press ON, and using the down feed levers to move the spinning drill bit into the workpiece.

For safe operation and optimum results, it is very important to follow these guidelines when drilling:

CLEARING CHIPS: Raise the drill bit often to clear chips and cool the drill bit. This will ease the work of the drill press motor and extend the life of your drill bits.

SECURING WORKPIECE TO TABLE: Secure the workpiece to the table or in a vise that is secured to the table before drilling.

PROTECTING TABLE: Protect the table by placing the workpiece on scrap wood, or center the location of the hole to be drilled over the pocket in the table when through drilling. Also, make use of the depth stop so that the drill bit goes no deeper than necessary.

USING CORRECT SPEEDS: Use the correct speed for the diameter of the drill bit being used and the type of material being drilled. Refer to the **Drill, Cutter, and Hole Saw Suggested RPM Chart** on **Page 28** to help you choose the correct speed for your application.

LARGE DIAMETER BITS: Large diameter drill bits require slower spindle speeds.

SMALL DIAMETER BITS: Smaller diameter drill bits require faster spindle speeds.

HARD MATERIAL: Harder materials (steel vs. wood) require slower drilling speeds.

SOFT MATERIAL: Soft materials require a faster drilling speed. (**NOTE:** Plastics can melt at too high of a spindle speed!)

CAUTION

Larger bits turning at slower speeds tend to grab the workpiece aggressively. This can result in the operator's hand being pulled into the bit or the workpiece being thrown with great force. Always clamp the workpiece to the table to prevent injuries.

LUBRICANT: Use lubricant on all materials except wood and cast iron. Refer to **Lubrication Suggestions on Page 27** to find the correct lubrication for your application.

DRILLING ACCURACY: To prevent drill bit wandering and ensure accurate placement of holes, mark the hole location with a center punch before drilling. Also consider using a center-point drill to start the hole.

PLUG/ROSETTE CUTTERS: Plug cutters and rosette cutters are for wood only.

5-FLUTE/2-FLUTE CUTTERS: Use a 5-flute cutter when cutting into plastics, brass, aluminum, and mild steel. A 2-flute cutter can aggressively grab the workpiece and damage the tool if used with materials other than wood.

SPADE BITS AND PLASTIC: When drilling plastic with a spade bit, use a spade bit with spurs.

HOLE SAWS: When using hole saws, apply firm and even pressure, so the saw teeth contact the surface all at the same time—not at an angle. You can also flip the workpiece and finish drilling from the other side.

Installing/Removing Drill Bits

Any drill bit you install in the chuck must be tight enough that it will not come loose during operation.

Installing a Drill Bit

1. DISCONNECT MACHINE FROM POWER!
2. Open the drill chuck wide enough to accept the shank of the drill bit (see Figure 29).
3. Insert the drill bit as far as possible into the chuck WITHOUT allowing the chuck jaws to touch the fluted portion of the bit, and hand-tighten the chuck.

Note: Make sure small bits are not trapped between the edges of two jaws; if they are, reinstall the drill bit or it will not be secure enough to use for drilling.

4. Final-tighten the drill bit with the chuck key.

Removing a Drill Bit

1. DISCONNECT MACHINE FROM POWER!
2. Use the chuck key to open the drill chuck, as shown in Figure 30, and catch the drill bit with a rag to protect your hands.

⚠ WARNING

TURN OFF and UNPLUG the drill press, and wait until all working parts are stopped before you attempt to change the drill bits. Otherwise, severe personal injury may occur!



Figure 29. Installing a drill bit.



Figure 30. Using the chuck key.

Adjusting Depth Stop

The Model W1669/W1670 has a depth stop that allows you to drill repeated non-through holes to the same depth every time.

The depth stop consists of a stud attached to the quill with two hex nuts that can be lowered or raised on the stud so the lower nut (depth nut) hits a stop bracket when the drill bit is lowered. The upper hex nut (jam nut) is then used to tighten against the depth nut to secure it in place so it doesn't move with repeated operations. **Figure 31** shows the various components of the depth stop.

The return height nut, on the base of the stud, limits the downfeed handle return distance, which is set by how high the nut is placed on the stud. This feature is useful for repetitive drilling motions.

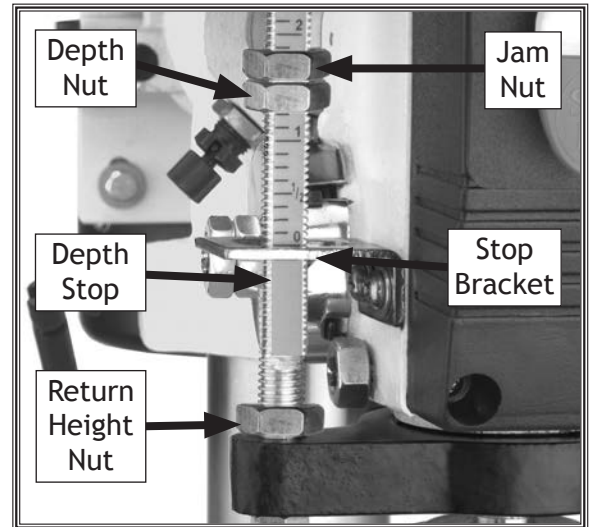

Figure 31. Depth stop components.

Setting Depth Stop

1. Lower the drill bit to the required height.
2. Thread the depth nut down against the stop bracket.
3. Lower the jam nut against the depth nut.
4. Using wrenches, hold the depth nut in place and tighten the jam nut against the depth nut.

Setting Spindle Return Distance

1. Lower the drill bit.
2. Thread the return height nut up the stud to the desired height.

Note: *The scale on the depth stop can be recalibrated if it gets moved or has changed since the factory setting. Refer to **Calibrating Depth Stop** on **Page 39** for instructions on how this is done.*

Adjusting Table

The Model W1669 table can be adjusted for height, angle, and location (see **Figure 32**). The W1670 table can also be adjusted for distance from column and rotation (see **Figure 33**).

Adjusting Table Height

1. Loosen the table bracket lock lever. Turn the table crank to raise or lower the table.
2. Remember to lock the support bracket in place before operating the machine.

Adjusting Table Tilt

1. **(W1670 Only):** Turn the locating pin nut (see **Figure 33**) in a clockwise direction. This will draw the locating pin out of the casting. Once loose, pull out the pin and nut, and set them in a safe place until needed.
2. Loosen the lock bolt (**Figure 34**) using the included wrench and tilt the table (W1669) or the column support arm (W1670) to the desired angle.
3. Lock in place by tightening the lock bolt.
4. **(W1670 Only):** To return the table to its original position, align the holes in the column support arm and table bracket, insert the locating pin and nut, and gently tap the pin with a hammer.
5. Tighten the locating pin nut.

Adjusting Table Rotation

1. Loosen the lock lever(s) located under the table (see **Figure 33**). Rotate the table the desired amount.
2. Always lock the table support arm in place before operating the machine.

Adjusting Distance from Column (W1670 Only)

1. Loosen the lock lever located at the pivoting elbow of the table support (see **Figure 33**).
2. Swing the table support to the desired distance from the column. The support bracket may need to be rotated around the column to keep the table centered under the chuck. Secure all lock levers before operating the machine.

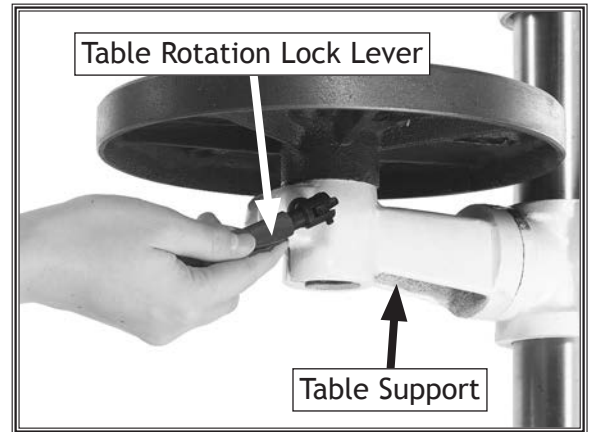

Figure 32. W1669 table components.

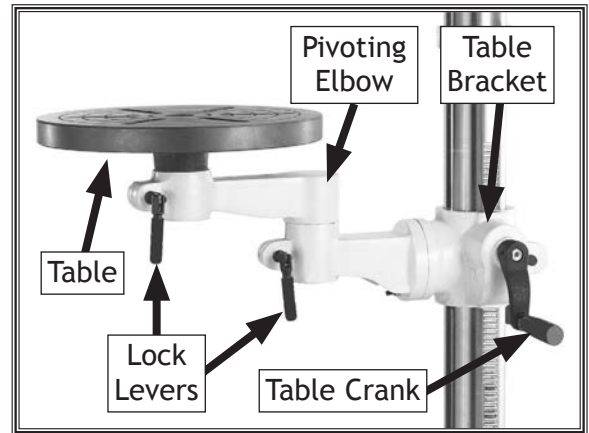

Figure 33. W1670 table components.

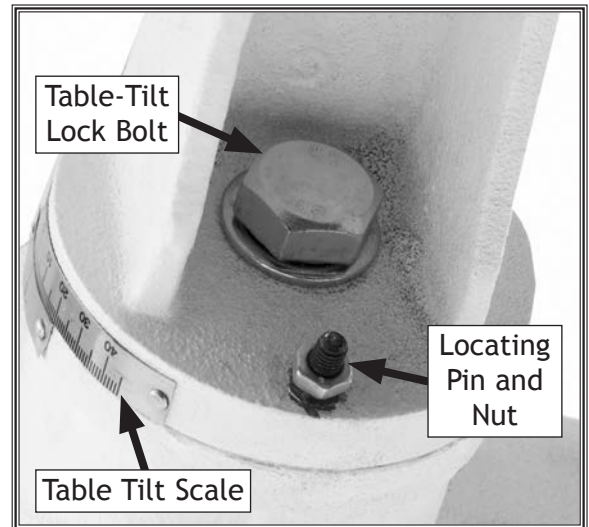

Figure 34. W1670 tilt mechanism and lock bolt (W1669 uses cap screw).

Adjusting Headstock

To drill wide workpieces up to 34" in diameter, you can slide the headstock in and out to increase the distance between the drill chuck and the column up to 17". You can also tilt the headstock from 45° clockwise to 90° counterclockwise for drilling angled holes or for horizontal boring machine use. Using the slide and tilt features, you can drill a line of straight or angled holes without the need to reposition your workpiece after drilling each hole.

Tilting Headstock

1. Loosen the lock lever on the right side of the headstock.
2. Pull out the lock pin located on the left side of the headstock and rotate the pin 90°, as shown in **Figure 35**.
3. Tilt the headstock to the desired angle specified on the scale and tighten the lock lever on the right side of the headstock.

Returning Head to Vertical Position

1. Loosen the lock lever located on the right side of the headstock.
2. Move the lock pin back into the guide slot.
3. Return the headstock to the vertical position. The headstock should lock into place.

Note: The lock pin is only intended to be a rough indexing tool.

4. For finer adjustments, align the zero mark on the headstock scale with the line on the horizontal column.
5. Tighten the lock lever.

Adjusting Headstock Back and Forth

1. Loosen the lock lever located on the left side of the headstock (see **Figure 36**).
2. Turn the adjustment knob, as shown in **Figure 36**, to move the headstock back and forth to the desired position. Tighten the lock lever before operating the machine.

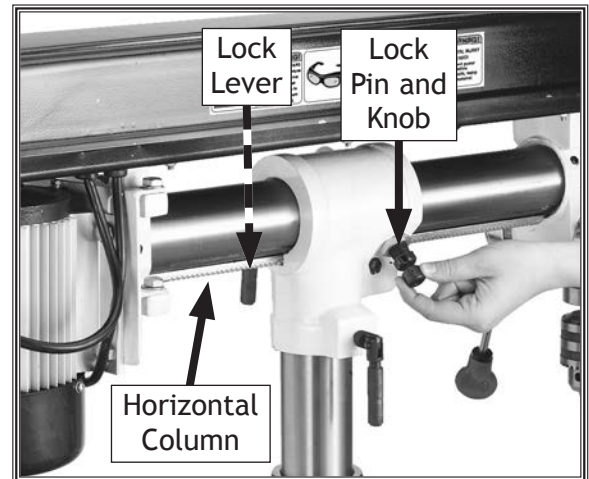

Figure 35. Headstock lock pin and knob and lock lever.

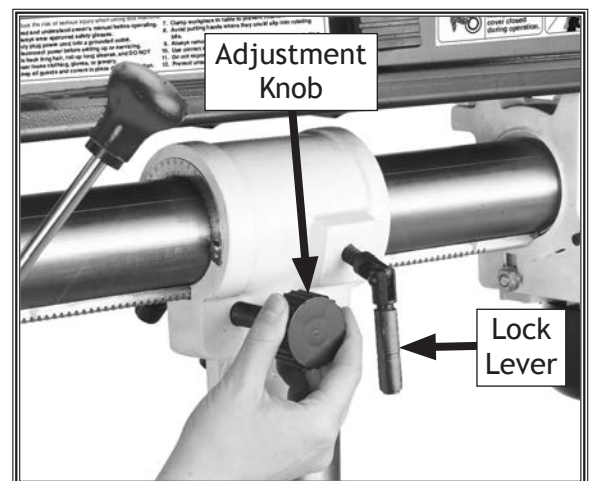

Figure 36. Headstock slide controls.

OPERATIONS

ACCESSORIES

Drill Press Accessories

The following Drill Press accessories may be available through your local Woodstock International Inc. Dealer. If you do not have a dealer in your area, these products are also available through online dealers. Please call or e-mail Woodstock International Inc. Customer Service to get a current listing of dealers at: 1-800-840-8420 or at sales@woodstockint.com.

Sanding Sleeves are sized to fit the D2677 Drum Sander Set. These hard Sanding Sleeves are available in 60, 80, 100, 120, and 150 grits. Keep plenty of these consumable sanding sleeves on hand.

Sanding Sleeves

| Size (D x H) | 60 Grit | 80 Grit | 100 Grit | 120 Grit | 150 Grit |
|-----------------|---------|---------|----------|----------|----------|
| 1" X 4 1/4" | D2683 | D2684 | D2685 | D2686 | D2687 |
| 1 1/2" X 4 1/4" | D2688 | D2689 | D2690 | D2691 | D2692 |
| 2" X 4 1/4" | D2693 | D2694 | D2695 | D2696 | D2697 |



D2677 Drum Sander Set includes three rubber sanding drums 4 1/4" in length to accommodate 1", 1 1/2" and 2" diameter sanding sleeves. This kit also includes one 80-grit sleeve for each drum to get things started.



D2722 Mandrel is a 3/8" shank and is required to use with the Drum Sander Set with any drill press.

Drill Press Clamps adjust quickly and easily to lock your workpiece in any position. The clamping pad pivots to conform to any workpiece, ensuring uniform pressure.



W1301 6" Drill Press Clamp (1 1/2" Capacity)

D2192 10" Drill Press Clamp (3" Capacity)

D2493 12" Drill Press Clamp (5" Capacity)

SHOP FOX® Drill Press Vises use precision-ground steel guide rods, smooth-action Acme threads, ground steel jaws with fixed jaw V-grooves for holding round stock, and dovetailed ways where applicable.

D3265 (4" Quick Release Vise)

D3270 (5" Quick Release Vise)

D3266 (6" Quick Release Vise)

D2933 (4" Angle Vise)

D2730 (3" Cross Sliding Vise)

D2731 (4" Cross Sliding Vise)

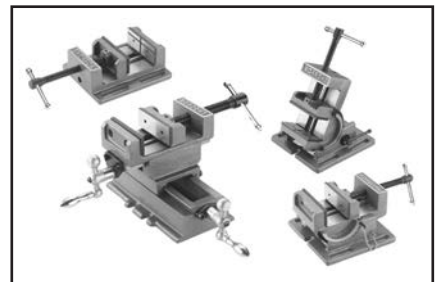

MAINTENANCE

General

Periodic maintenance on your Model W1669 and W1670 Radial Drill Press will ensure its optimum performance. Make a habit of inspecting your drill press after each use.

Check for the following conditions and repair or replace when necessary.

1. Loose or missing base mounting bolts.
2. Worn switch.
3. Worn or damaged cords and plugs.
4. Damaged drive belt.
5. Any other condition that could hamper the safe operation of this machine.

⚠ WARNING

MAKE SURE that your machine is unplugged during all maintenance procedures! If this warning is ignored, serious personal injury may occur.

Cleaning & Protecting

Cleaning the Model W1669/W1670 is relatively easy. Vacuum excess wood chips and sawdust, and wipe off the remaining dust with a dry cloth. If any resin has built up, use a resin dissolving cleaner to remove it.

Protect the unpainted cast iron table by wiping it clean after every use—this ensures moisture from wood dust does not remain on bare metal surfaces. Keep your table rust-free with regular applications of quality lubricants.

Lubrication

Since all bearings are shielded and permanently lubricated, simply leave them alone until they need to be replaced. **DO NOT** lubricate them.

For other items on this machine, such as the quill, table and column, horizontal and vertical columns, an occasional application of light machine oil is all that is necessary to maintain smooth rust-free operation.

Before applying any lubricant, clean off the old lubricant, and any sawdust or metal chips.

DO NOT over lubricate, your goal is to achieve adequate lubrication. Too much lubrication will attract dirt and sawdust, and various parts of your machine could lose freedom of movement.

Inspecting/ Replacing V-Belts

Inspect V-belts regularly for tension and wear. Refer to **Figure 37** for proper belt tension. Belt deflection should be approximately $\frac{3}{4}$ " under moderate pressure. Check pulleys to ensure that they are properly aligned when installing V-belts.

To replace the V-belts, refer to **Adjusting Belt Tension** on **Page 38** to loosen the belts. Remove them from the pulleys, then install new V-belts and adjust tension.

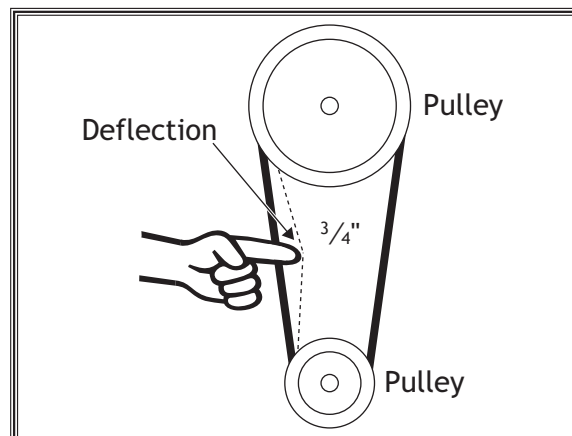

Figure 37. Inspecting V-belt tension.

MAINTENANCE

SERVICE

General

This section covers the most common service adjustments or procedures that may need to be made during the life of your machine.

If you require additional machine service not included in this section, please contact Woodstock International Technical Support at (360) 734-3482 or send e-mail to: techsupport@woodstockint.com.

Adjusting Belt Tension

During the life of your drill press you will use different belt and pulley combinations. No matter which pulley combination you use, make sure that the belt is tensioned properly.

To adjust belt tension, do these steps:

1. DISCONNECT THE MACHINE FROM POWER!
2. Open the belt safety cover (see **Figure 38**).
3. Loosen both motor lock knobs at the side of the headstock (see **Figure 39**).
4. Slide the motor away from the headstock until the belt is taut.
5. Hold the motor in position, then tighten the lock screw and make sure the belt deflection gap is correct when pinched together between the pulleys (see **Figure 40**).
 - If the gap between both inner sides of the belt is greater or less than $\frac{3}{4}$ " , repeat **Steps 3-5** until the deflection gap is $\frac{3}{4}$ " .
 - If the deflection gap is $\frac{3}{4}$ " the belt is tensioned correctly.
6. Close the belt safety cover.



Figure 38. Belt safety cover opened.

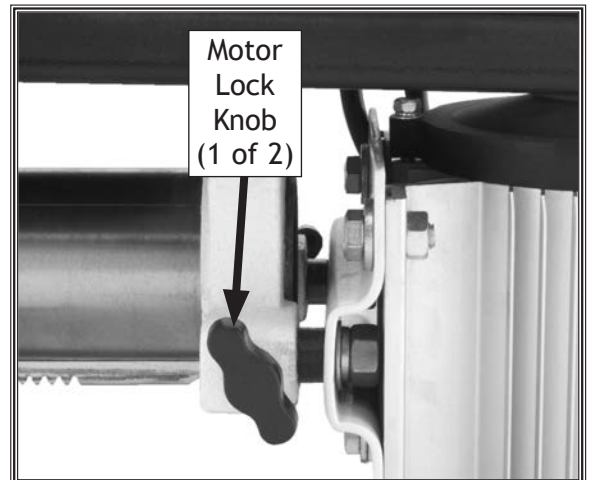

Figure 39. Motor lock knob.



Figure 40. Measuring belt deflection.

Calibrating Depth Stop

The drill press comes fitted with a depth stop to use when drilling multiple holes at the same depth. The scale on this depth stop can be calibrated if it ever becomes incorrect.

To calibrate the depth stop, do these steps:

1. Loosen the return height nut and calibration nut shown in Figure 41.
2. Use the calibration nut to zero the depth stop scale with the stop bracket.
3. Hold the depth stop at zero, and tighten the return height nut to hold the depth stop in position.
4. Test the depth stop by measuring how far the spindle actually moves with respect to where you set the depth stop.

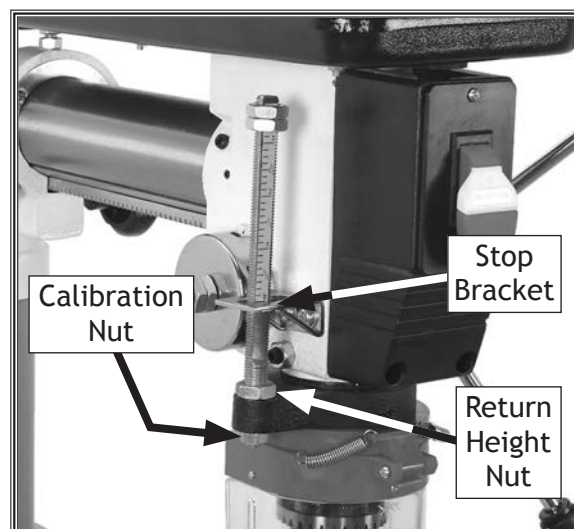

Figure 41. Depth-stop components.

Adjusting Spindle Return Spring Tension

The tension of the spindle return spring makes the spindle automatically return to the top (starting) position when the downfeed handle is released. This spring is pre-adjusted at the factory, and typically will never need further adjustment during the life of the drill press. However, additional tension can be applied if the spindle stops automatically returning to the top position.

To adjust the spindle return spring tension, do these steps:

1. DISCONNECT THE MACHINE FROM POWER!
2. Wipe off any oil on the spring-lock cover so it will not slip when you hold the cover from spinning (see Figure 42).

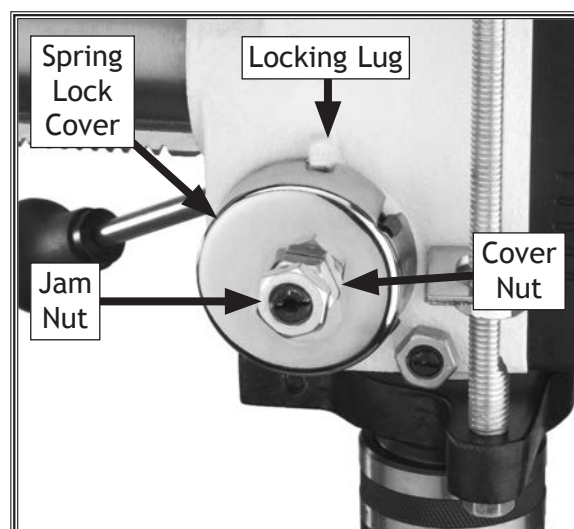

Figure 42. Spindle return spring components.

- While holding the spring lock cover against the side of the headstock so the cover stays splined with the locking lug, as shown in **Figure 43**, loosen the jam nut and loosen the cover nut approximately $\frac{1}{4}$ " each.

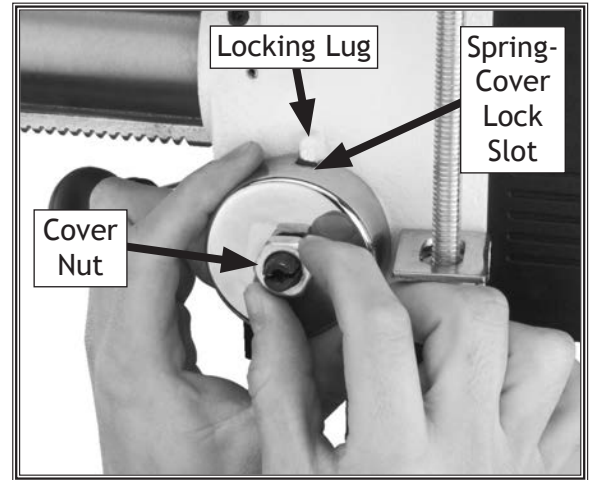

Figure 43. Hold the spring cover tightly while loosening jam nut and cover nut.

- Put on heavy leather gloves to protect your hands from possible lacerations if the spring uncoils during the next step (see **Figure 44**).
- Pull the cover outward just enough to disengage the spring-cover lock slot from the locking lug (see **Figure 43**).

CAUTION: *It is important to keep a good grip during this step. Letting go of the cover will cause the spring to rapidly uncoil.*

- Rotate the cover counterclockwise to increase spring tension, or let the cover slowly unwind in the clockwise direction to reduce spring tension (see **Figure 44**).
- Engage the next available spring-cover lock slot with the locking lug and hold the spring lock cover tightly against the side of the headstock.
- Snug the cover nut against the spring cover just until the nut stops, and then back off the nut approximately $\frac{1}{3}$ turn, or just enough so there is no binding at complete spindle travel.
- Hold the cover nut and tighten the jam nut against the cover nut.

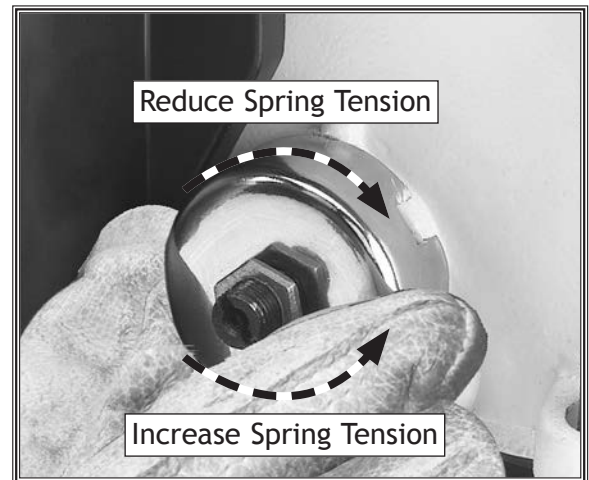
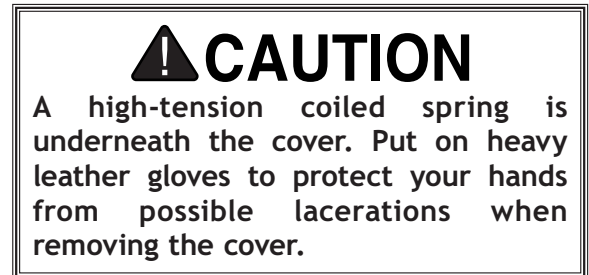

Figure 44. Turning cover to adjust spindle return spring tension.

Adjusting Quill-Shaft Screw

While you may never have to adjust the quill-shaft screw, you should understand its function and know how to adjust it should you ever need to remove the quill for cleaning. This screw prevents the quill from rotating during drilling and sanding procedures, and if adjusted incorrectly, the quill may have lash or bind.

To adjust the quill-shaft screw, do these steps:

1. DISCONNECT THE MACHINE FROM POWER!
2. Clean the quill shaft and lubricate it with a thin coat of light oil, so the quill travels freely (see Figure 45).
3. Loosen the jam nut (see Figure 46).
4. Move the quill up and down through the entire range of travel, and turn the quill-shaft screw inward as far as it can go without binding the quill.
5. Tighten the jam nut, and check the quill movement for binding or play while moving the quill up and down through its entire range of travel.
6. Re-adjust the quill-shaft screw as required.



Figure 45. Clean and oil quill shaft.

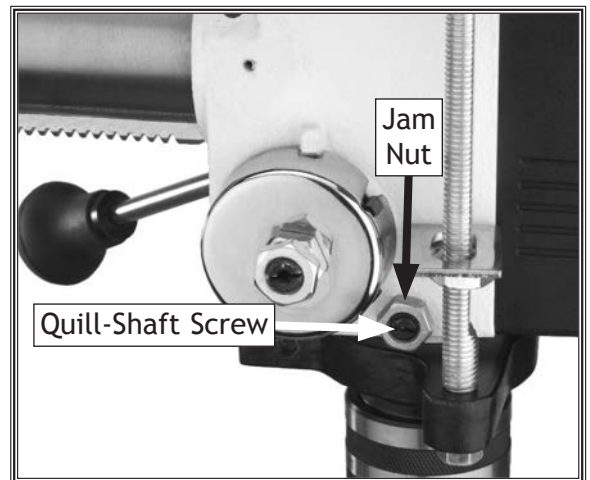

Figure 46. Quill-shaft screw and jam nut.

Troubleshooting

The following troubleshooting tables cover common problems that may occur with this machine. If you need replacement parts or additional troubleshooting help, contact our Technical Support.

Note: Before contacting Tech Support, find the machine serial number and manufacture date, and if available, your original purchase receipt. This information is required to properly assist you.

Motor & Electrical

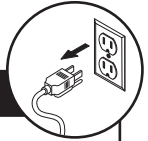

| Symptom | Possible Cause | Possible Solution |
|--------------------------------------------|-----------------------------------------------------------------------------------------------------------------------------------------------------------------------------------------------------------------------------------------------------------------------------------------------------------------------------------------------------------------------------------------------------------------------------------|--------------------------------------------------------------------------------------------------------------------------------------------------------------------------------------------------------------------------------------------------------------------------------------------------------------------------------------------------------------------------------------------------------------------------------------------------------------------------------------------------------------------------------------|
| Machine does not start or a breaker trips. | <ol style="list-style-type: none"> 1. Switch disabling key removed or at fault. 2. Incorrect power supply voltage or circuit size. 3. Power supply circuit breaker tripped or fuse blown. 4. Motor wires connected incorrectly. 5. Wiring open/has high resistance. 6. Start capacitor at fault. 7. Centrifugal switch at fault. 8. Motor at fault. | <ol style="list-style-type: none"> 1. Insert disabling key or replace. 2. Ensure correct power supply voltage and circuit size. 3. Ensure circuit is sized correctly and free of shorts. Reset circuit breaker or replace fuse. 4. Correct motor wiring connections (Page 40). 5. Check/fix broken, disconnected, or corroded wires. 6. Test/replace. 7. Adjust/replace centrifugal switch if available. 8. Test/repair/replace. |
| Machine stalls or is underpowered. | <ol style="list-style-type: none"> 1. Incorrect/dull cutter/bit for task. 2. Feed rate/cutting speed too fast. 3. Belt(s) slipping. 4. Machine undersized for task. 5. Motor overheated. 6. Pulley slipping on shaft. 7. Centrifugal switch at fault. 8. Motor at fault. | <ol style="list-style-type: none"> 1. Use correct cutter/bit. 2. Decrease feed rate/cutting speed (Page 30). 3. Ensure belts are oil free, tension/replace belt(s); ensure pulleys are aligned. 4. Perform operation with different machine. 5. Clean motor, let cool, and reduce workload. 6. Tighten loose pulley; replace broken/missing parts. 7. Adjust/replace centrifugal switch if available. 8. Test/repair/replace. |
| Machine has vibration or noisy operation. | <ol style="list-style-type: none"> 1. Motor or other drive component loose. 2. V-belt(s) worn or loose. 3. Motor fan rubbing on fan cover. 4. Pulley loose. 5. Motor mount loose/broken. 6. Motor or spindle bearings at fault. 7. Chuck unbalanced or cutter dull. | <ol style="list-style-type: none"> 1. Inspect/replace damaged bolts/nuts, and retighten with thread locking fluid, if necessary. 2. Inspect/replace belts with a new matched set (Page 37). 3. Fix/replace fan cover; replace loose/damaged fan. 4. Re-align/replace shaft, pulley set screw, and key. 5. Tighten/replace. 6. Test by rotating shaft; rotational grinding/loose shaft requires bearing replacement. 7. Replace chuck; replace/resharpen cutter. |

Drill Press Operations

| Symptom | Possible Cause | Possible Solution |
|----------------------------------------------------------|-----------------------------------------------------------------------------------------------------------------------------------------------------------------------------------------------------------------------------------------------------------------------------------------------------|------------------------------------------------------------------------------------------------------------------------------------------------------------------------------------------------------------------------------------------------------------------------------------------------------------------------------------------------------------------------------------------------------|
| Tool loose/lack of power in spindle. | <ol style="list-style-type: none"> 1. Tool incorrectly installed in spindle taper. 2. Debris on tool or spindle taper mating surfaces. 3. Taking too big of a cut. 4. V-belts are loose. 5. Wrong voltage. | <ol style="list-style-type: none"> 1. Remove and re-install (Page 1). 2. Clean tool and spindle taper. 3. Lessen depth of cut and allow chips to clear (Page 31). 4. Properly tension V-belts (Page 37). 5. Correct voltage. |
| Workpiece or tool vibrates or chatters during operation. | <ol style="list-style-type: none"> 1. Table locks not tight. 2. Workpiece not secure. 3. Spindle speed/feed rate is too fast. 4. Spindle or quill extended too far down. 5. Quill shaft screw not tight. | <ol style="list-style-type: none"> 1. Tighten table locks (Page 34). 2. Properly clamp workpiece on table or in vise. 3. Set spindle speed correctly (Page 30) or use slower feed rate. 4. Fully retract spindle and lower headstock. This increases rigidity to decrease vibration. 5. Tighten quill shaft screw (Page 41). |
| Headstock is hard to raise. | <ol style="list-style-type: none"> 1. Headstock lock nuts at fault. 2. Rack and pinion at fault or jammed with grime/debris. | <ol style="list-style-type: none"> 1. Loosen/replace lock nuts. 2. Fix/replace broken or loose parts; clean and lubricate rack and pinion. |
| Bad surface finish. | <ol style="list-style-type: none"> 1. Spindle speed too fast for workpiece material. 2. Dull or incorrect cutting tool. 3. Wrong rotation direction of cutting tool. 4. Workpiece not secure. 5. Spindle extended too far down during operation. | <ol style="list-style-type: none"> 1. Set spindle speed correctly (Page 30). 2. Sharpen cutting tool or select one that better suits the operation. 3. Check for proper cutting tool rotation. 4. Properly clamp workpiece on table or in vise. 5. Fully retract spindle and lower headstock. This increases rigidity. |
| Spindle overheats. | <ol style="list-style-type: none"> 1. Drill operated at high speeds for extended period. | <ol style="list-style-type: none"> 1. Allow drill to cool. |
| Spindle does not return to highest position. | <ol style="list-style-type: none"> 1. Poorly adjusted spindle return spring. 2. Worn return spring. | <ol style="list-style-type: none"> 1. Increase spindle return spring tension (Page 39). 2. Replace return spring. |
| Depth stop producing inaccurate results. | <ol style="list-style-type: none"> 1. Depth stop not calibrated. | <ol style="list-style-type: none"> 1. Calibrate depth stop (Page 39). |

Electrical Safety Instructions

These pages are current at the time of printing. However, in the spirit of improvement, we may make changes to the electrical systems of future machines. Compare the manufacture date of your machine to the one stated in this manual, and study this section carefully.

If there are differences between your machine and what is shown in this section, call Technical Support at (360) 734-3482 for assistance BEFORE making any changes to the wiring on your machine. An updated wiring diagram may be available. **Note:** Please gather the serial number and manufacture date of your machine before calling. This information can be found on the main machine label.

WARNING

SHOCK HAZARD. Working on wiring that is connected to a power source is extremely dangerous. Touching electrified parts will result in personal injury including but not limited to severe burns, electrocution, or death. Disconnect the power from the machine before servicing electrical components!

QUALIFIED ELECTRICIAN. Due to the inherent hazards of electricity, only a qualified electrician should perform wiring tasks on this machine. If you are not a qualified electrician, get help from one before attempting any kind of wiring job.

WIRE CONNECTIONS. All connections must be tight to prevent wires from loosening during machine operation. Double-check all wires disconnected or connected during any wiring task to ensure tight connections.

WIRE/COMPONENT DAMAGE. Damaged wires or components increase the risk of serious personal injury, fire, or machine damage. If you notice that any wires or components are damaged while performing a wiring task, replace those wires or components before completing the task.

MODIFICATIONS. Using aftermarket parts or modifying the wiring beyond what is shown in the diagram may lead to unpredictable results, including serious injury or fire.

MOTOR WIRING. The motor wiring shown in these diagrams is current at the time of printing, but it may not match your machine. Always use the wiring diagram inside the motor junction box.

CAPACITORS/INVERTERS. Some capacitors and power inverters store an electrical charge for up to 10 minutes after being disconnected from the power source. To reduce the risk of being shocked, wait at least this long before working on capacitors.

CIRCUIT REQUIREMENTS. You MUST follow the requirements at the beginning of this manual when connecting your machine to a power source.

EXPERIENCING DIFFICULTIES. If you are experiencing difficulties understanding the information included in this section, contact our Technical Support at (360) 734-3482.

NOTICE

The photos and diagrams included in this section are best viewed in color. You can view these pages in color at www.shopfox.biz.

WIRING DIAGRAM COLOR KEY

| | | | |
|-------|--------|--------------|------------|
| BLACK | BLUE | YELLOW | LIGHT BLUE |
| WHITE | BROWN | YELLOW GREEN | BLUE WHITE |
| GREEN | GRAY | PURPLE | TUR-QUOISE |
| RED | ORANGE | PINK | |

Wiring Diagram

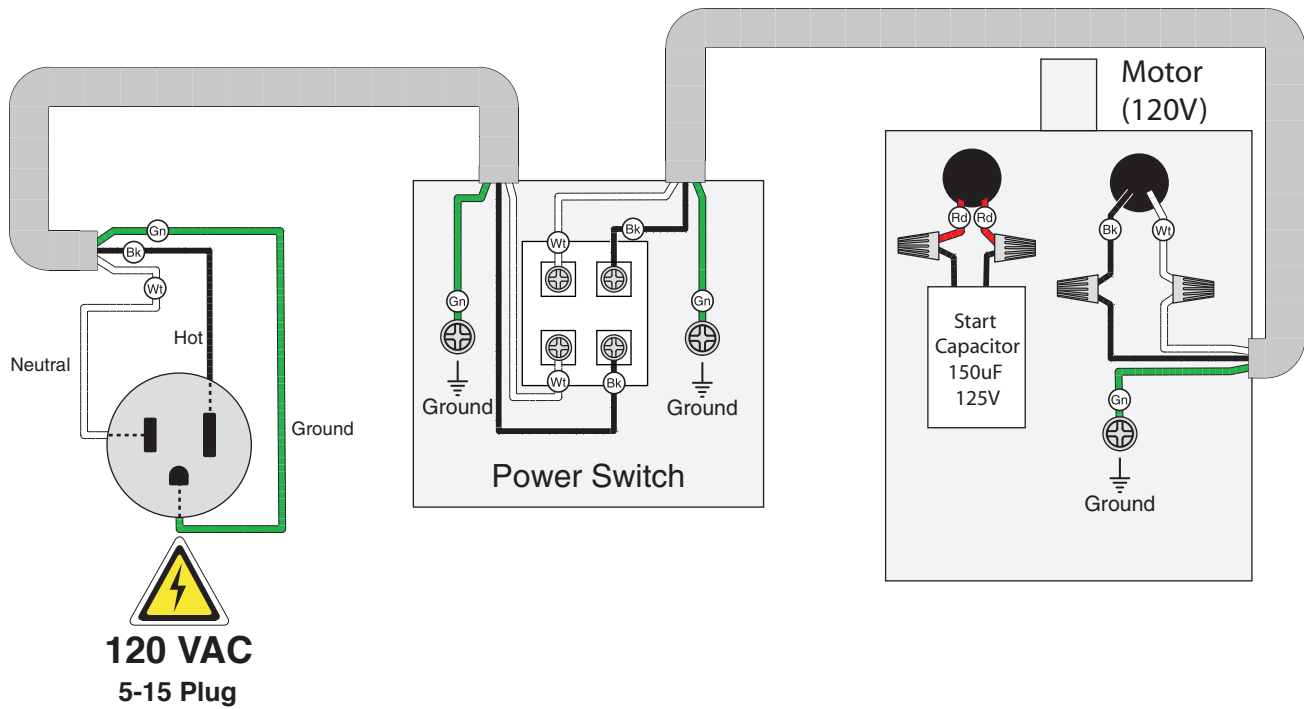

SERVICE

Headstock Parts List

| REF | PART # | DESCRIPTION |
|-------|-------------|---------------------------|
| 8 | X1669008 | GEAR |
| 9 | X1669009 | EXT RETAINING RING 9MM |
| 10 | X1669010 | HEX NUT M8-1.25 |
| 11 | X1669011 | CLAMP BOLT M10-1.5 X 30 |
| 15 | X1669015 | KNOB BOLT M8-1.25 X 16 |
| 16A | X1669016A | MOUNT PLATE V2.10.04 |
| 16A-1 | X1669016A-1 | MOTOR MOUNT PLATE |
| 19 | X1669019 | MOTOR 1/2 HP, 120V |
| 19-1 | X1669019-1 | S. CAPCTR 150MFD/125VAC |
| 19-2 | X1669019-2 | CAPACITOR COVER |
| 19-3 | X1669019-3 | MOTOR FAN |
| 19-4 | X1669019-4 | FAN COVER |
| 19-5 | X1669019-5 | PHLP HD SCR M4-.75 X 6 |
| 19-6 | X1669019-6 | FLAT WASHER 4MM |
| 20 | X1669020 | PULLEY COVER |
| 21 | X1669021 | MOTOR PULLEY |
| 22 | X1669022 | V-BELT 0-1480 |
| 23 | X1669023 | UNTHREADED FEMALE KNOB |
| 24 | X1669024 | LOCK PIN ASSEMBLY |
| 25 | X1669025 | SPINDLE PULLEY |
| 26 | X1669026 | DRIVE SLEEVE |
| 27 | X1669027 | INT RETAINING RING M40 |
| 28 | X1669028 | BEARING 6203 |
| 28A | X1669028A | SPACER |
| 29 | X1669029 | KNOB |
| 30 | X1669030 | LEVER |
| 31 | X1669031 | LOCK NUT 1/2"-20 |
| 32 | X1669032 | COVER WITH SPRING |
| 32-1 | X1669032 | COVER WITH SPRING |
| 33 | X1669033 | HORIZONTAL COLUMN |
| 33-1 | X1669033-1 | HORIZONTAL COLUMN RACK |
| 34 | X1669034 | HEADSTOCK |
| 35 | X1669035 | SWITCH AND KEY |
| 35-1 | X1669035-1 | SWITCH KEY |
| 36 | X1669036 | SET SCREW 5/16"-18 X 3/8" |
| 37 | X1669037 | PHLP SCREW 10-24 X 5/8" |
| 38 | X1669038 | SWITCH BOX |
| 38-1 | X1669038-1 | SWITCH MOUNTING PLATE |
| 39 | X1669039 | RUBBER WASHER |
| 40 | X1669040 | QUILL SHAFT |
| 41 | X1669041 | BEARING 6202 |
| 42 | X1669042 | SPINDLE JT#33 |
| 43 | X1669043 | CHUCK KEY |
| 44 | X1669044 | 1/2" CHUCK 1-16MM JT#33 |
| 45 | X1669045 | COLLAR |
| 45A-1 | X1669045A-1 | DEPTH STOP ROD N/S |
| 45A-2 | X1669045A-2 | DEPTH STOP ROD BRACKET |

| REF | PART # | DESCRIPTION |
|-------|-------------|-------------------------------|
| 45A-3 | X1669045A-3 | DEPTH STOP MOUNT |
| 46 | X1669046 | FEED SHAFT |
| 47 | X1669047 | FEED COLLAR |
| 48 | X1669048 | HANDLE |
| 49 | X1669049 | DEGREE SCALE |
| 50 | X1669050 | EXT RETAINING RING 12M |
| 51 | X1669051 | BEARING 6201 |
| 52 | X1669052 | POWER CORD |
| 53 | X1669053 | SET SCREW |
| 53A | X1669053A | PULLEY LOCK NUT V2.01.05 |
| 54 | X1669054 | PHLP SCREW 1/4"-20 X 3/8" |
| 56 | X1669056 | RIVET |
| 59 | X1669059 | SPECL SET SCR 5/16"-18 X 1" |
| 60 | X1669060 | HEX NUT 5/16"-18 |
| 63 | X1669063 | WIRE STRAP |
| 64 | X1669064 | PHLP SCREW 10-24 X 3/8" |
| 65 | X1669065 | MOTOR SWITCH CORD |
| 76 | X1669076 | LOCKING GIB |
| 77 | X1669077 | FLAT WASHER 8MM |
| 79 | X1669079 | FLAT WASHER 12MM |
| 81 | X1669081 | HEX BOLT M8-1.25 X 20 |
| 85 | X1669085 | SAFETY GOGGLES LABEL V1 |
| 86 | X1669086 | LONG HAIR SAFETY LABEL |
| 87 | X1669087 | HEX WRENCH 3MM |
| 88 | X1669088 | HEX WRENCH 5MM |
| 89 | X1669089 | SELF TAP SCREW #8 X 3/8" |
| 93 | X1669093 | RUBBER WASHER 8MM |
| 94 | X1669094 | GUIDE ROD 16 X 30MM |
| 102 | X1669102 | HEX NUT M10-1.5 |
| 102-1 | X1669102-1 | PHLP HD SCR M4-.7 X30 |
| 102-2 | X1669102-2 | HEX NUT M4-.7 |
| 102-3 | X1669102-3 | TAP SCREW M2.2 X 4.5 |
| 102-4 | X1669102-4 | HEX BOLT M5-.8 X 12 |
| 102-5 | X1669102-5 | WING NUT M5-.8 |
| 102-6 | X1669102-6 | PHLP HD SCR M4-.7 X 10 |
| 102-7 | X1669102-7 | FLAT WASHER 4MM |
| 103 | X1669103 | LOCK WASHER 10MM |
| 104 | X1669104 | FLAT WASHER 6MM |
| 105 | X1669105 | PHLP HD SCR M6-1 X 10 |
| 106 | X1669106 | HEX NUT M8-1.25 |
| 107 | X1669107 | HEX NUT M10-1.5 |
| 108 | X1669108 | CAP SCREW M8-1.25 X 20 |
| 109 | X1669109 | RUBBER BUMPER |
| 110 | X1669110 | ROLL PIN 6 X 20 |
| 111 | X1669111 | ROLL PIN 5 X 40 |
| 112 | X1669112 | STRAIN RELIEF TYPE-1 M12-1.75 |

W1669 Table & Column

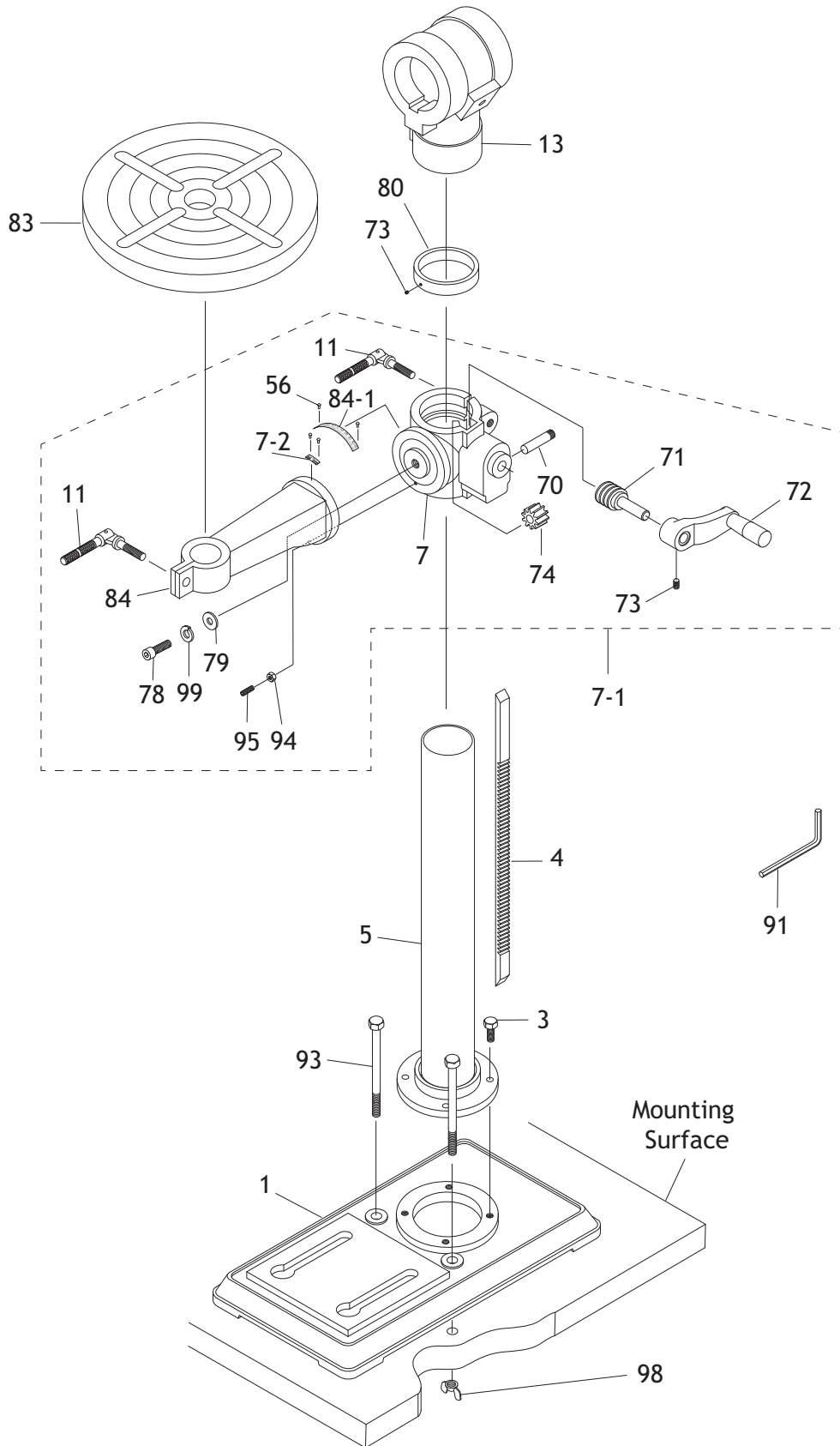



W1669 Table & Column Parts List

| REF | PART # | DESCRIPTION |
|-----|------------|---------------------------|
| 1 | X1669001 | BASE |
| 3 | X1669003 | HEX BOLT M8-1.25 X 20 |
| 4 | X1669004 | W1669 RACK |
| 5 | X1669005 | W1669 COLUMN |
| 7 | X1669007 | GEARED TBL BRKT N/S |
| 7-1 | X1669007-1 | COMPLETE TBL BRKT ASSY |
| 7-2 | X1669007-2 | TABLE TILT SCALE |
| 11 | X1669011 | CLAMP BOLT M10-1.5 X 30 |
| 13 | X1669013 | HORR. COLUMN BRKT |
| 54 | X1669054 | PHLP SCREW 1/4"-20 X 3/8" |
| 56 | X1669056 | RIVET |
| 70 | X1669070 | PIN |
| 71 | X1669071 | WORM PINION |

| REF | PART # | DESCRIPTION |
|------|------------|----------------------------|
| 72 | X1669072 | LIFT HANDLE CRANK |
| 73 | X1669073 | SET SCREW M6-1.0 X 10 |
| 74 | X1669074 | 10T GEAR |
| 78 | X1669078 | CAP SCREW M12-1.75 X 30 |
| 79 | X1669079 | FLAT WASHER 12MM |
| 80 | X1669080 | COLUMN RING |
| 83 | X1669083 | TABLE |
| 84 | X1669084 | COLUMN SUPPORT ARM N/S |
| 84-1 | X1669084-1 | TABLE TILT SCALE INDICATOR |
| 91 | X1669090 | HEX WRENCH 10MM |
| 93 | X1669093 | RUBBER WASHER 8MM |
| 99 | X1669099 | LOCK WASHER 12MM |
| 98 | X1669098 | WING NUT M8-1.25 |

W1670 Table & Column

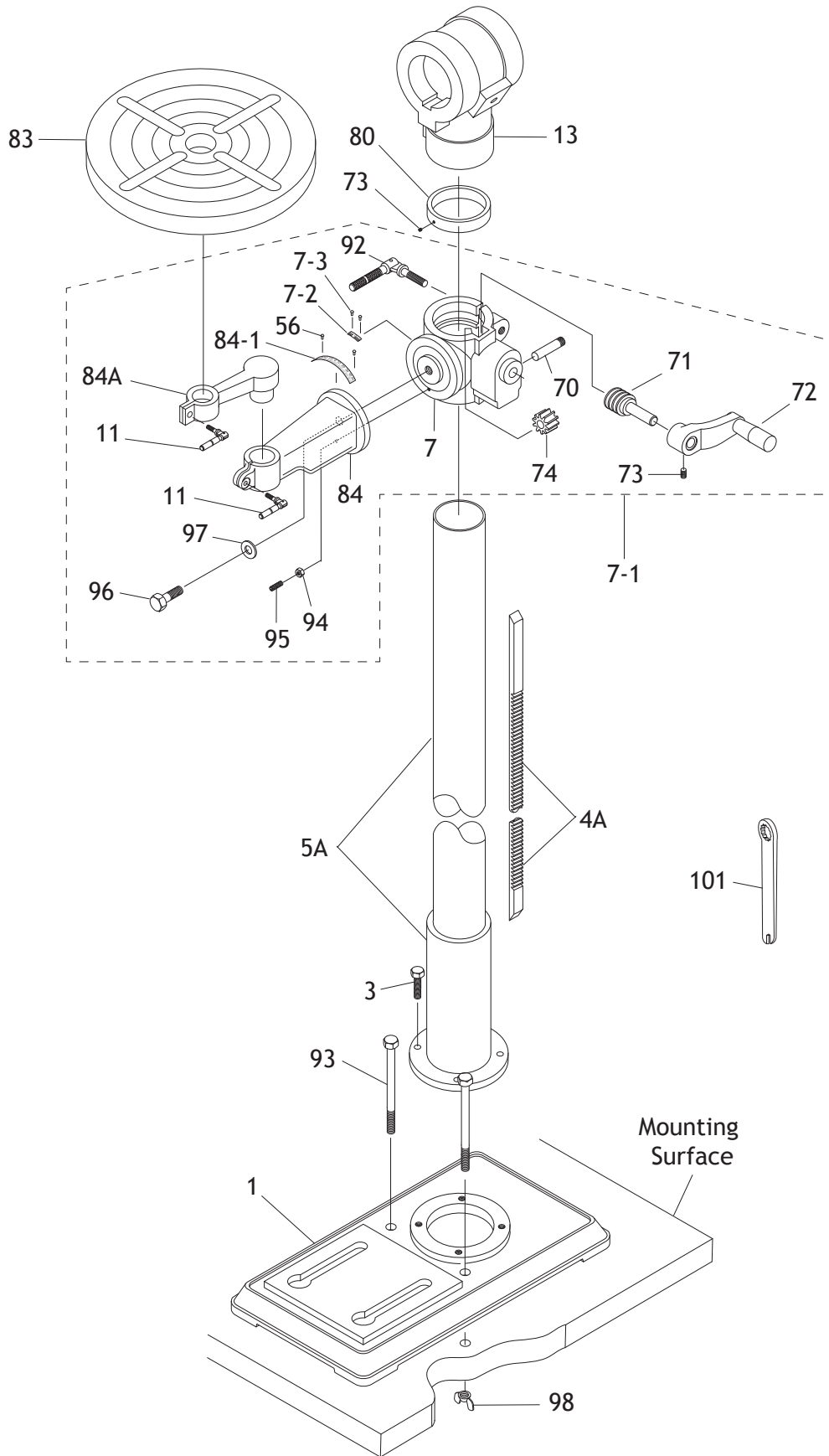

W1670 Table & Column Parts List

| REF | PART # | DESCRIPTION |
|-----|------------|--------------------------|
| 1 | X1670001 | BASE |
| 3 | x1670003 | HEX BOLT M8-1.25 X 40 |
| 4A | X1670004A | W1670 RACK |
| 5A | X1670005A | W1670 COLUMN |
| 7 | X1670007 | GEARED TABLE BRACKET N/S |
| 7-1 | X1670007-1 | TABLE BRACKET ASSY |
| 7-2 | X1670007-2 | DEGREE SCALE |
| 7-3 | X1670007-3 | RIVET |
| 11 | X1670011 | LOCK LEVER M10-1.5 X 30 |
| 13 | X1670013 | HORIZ. COLUMN BRACKET |
| 56 | X1670056 | RIVET |
| 70 | X1670070 | AXLE |
| 71 | X1670071 | WORM PINION |
| 72 | X1670072 | LIFT HANDLE |
| 73 | X1670073 | SET SCREW M6-1 X 10 |

| REF | PART # | DESCRIPTION |
|------|------------|--------------------------|
| 74 | X1670074 | WORM GEAR |
| 80 | X1670080 | COLUMN RING |
| 83 | X1670083 | TABLE |
| 84 | X1670084 | COLUMN SUPPORT ARM N/S |
| 84A | X1670084A | TABLE SUPPORT ARM |
| 84-1 | X1670084-1 | TABLE TILT SCALE |
| 92 | X1670092 | LOCK LEVER M12-1.75 x 50 |
| 93 | X1670093 | HEX BOLT M8-1.25 X 125 |
| 94 | X1670094 | GUIDE ROD 16 X 30MM |
| 95 | X1670095 | SPECIAL PIN |
| 96 | X1670096 | HEX BOLT 5/8-13 X 1-1/2 |
| 97 | X1670097 | FLAT WASHER 5/8 |
| 98 | X1670098 | WING NUT M8-1.25 |
| 101 | X1670101 | SPECIAL WRENCH |

Labels & Cosmetics

75V2

| | | |
|--------------------------------------------------------------------------------------------------------------|---------------------------------------------------------------------------------------------------------------------------------------------------------------------------------------------------------------------------------------------------------------------|------------------------------------------------------------------------------------------------------------------------------------------------------------------------------------------------------------------------------------------------------------------------------------------------------------------------------------------------------------------------------------------------------------------------------------------------------------------------------------------------------------------------------------------------------------------------------------------------------------------------------------------------------------------------------------------------------------------------------------------------------------------------------------------------------------------------------------------------------------------------------------------------------------------------------------------------------------------------------|
| <p>MODEL W1669 BENCHTOP RADIAL DRILL PRESS <small>Mfg. for Woodstock in China</small></p> | <p>Specifications</p> <p>Motor: 1/2 HP, 120V, 4.7A, 60 Hz Swing: 34" Spindle Speeds: 550-3000 RPM Spindle to Table Dist.: 11-1/2" Spindle to Base Dist.: 17-1/2" Spindle Travel: 3-1/4" Spindle Taper: JT1/2 Weight: 91 lbs.</p> | <p>WARNING!</p> <p>To reduce the risk of serious injury when using this machine:</p> <ol style="list-style-type: none"> 1. Read and understand owner's manual before operating. 2. Always wear approved safety glasses. 3. Only plug power cord into a grounded outlet. 4. Disconnect power before setting up or servicing. 5. Tie back long hair, roll up long sleeves, and DO NOT wear loose clothing, gloves, or jewelry. 6. Keep all guards and covers in place during operation. 7. Clamp workpiece to table to prevent rotation. 8. Avoid putting hands where they could slip into rotating bits. 9. Always remove chuck keys and other tools before starting. 10. Use correct speeds for drilling accessories and workpiece. 11. Do not expose to rain or use in wet locations. 12. Prevent unauthorized use by children or untrained users. |
| | <p>CSA C 194841</p> <p>SN</p> | |

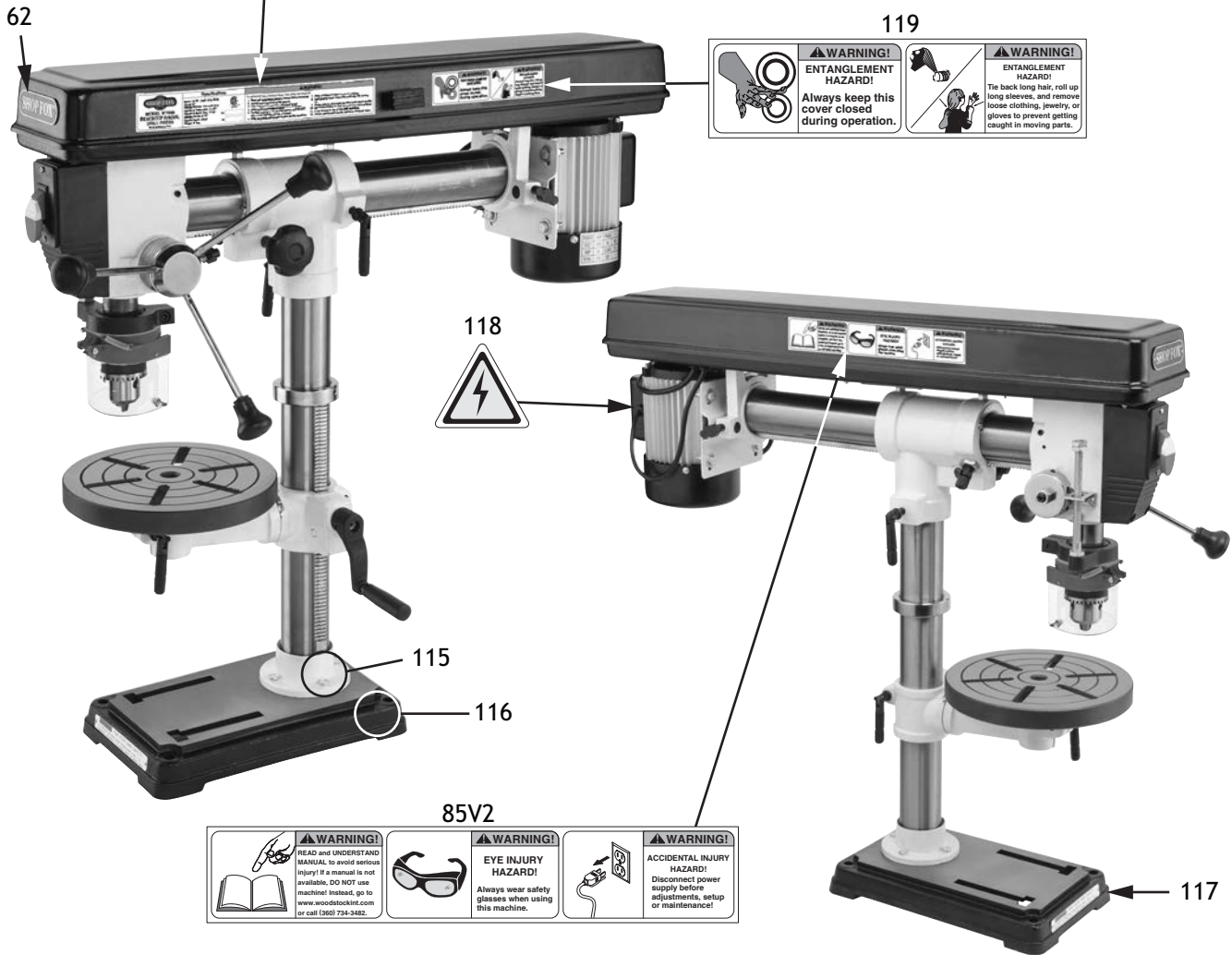

| REF | PART # | DESCRIPTION |
|------|------------|---------------------------------------|
| 62 | X1669062 | SHOP FOX NAMEPLATE |
| 75V2 | X1669075V2 | MACHINE ID LABEL CSA V2.09.17 (W1669) |
| 75V2 | X1670075V2 | MACHINE ID LABEL CSA V2.09.17 (W1670) |
| 85V2 | X1669085V2 | COMBO WARNING LABEL V2.06.22 |
| 115 | X1669115 | TOUCH-UP PAINT, SHOP FOX WHITE |

| REF | PART # | DESCRIPTION |
|-----|----------|--------------------------------|
| 116 | X1669116 | TOUCH-UP PAINT, SHOP FOX BLACK |
| 117 | X1669117 | TIPPING HAZARD LABEL |
| 118 | X1669118 | ELECTRICITY LABEL |
| 119 | X1669119 | KEEP COVER CLOSED LABEL |

WARNING

Safety labels warn about machine hazards and how to prevent serious personal injury. The owner of this machine **MUST** maintain the original location and readability of all labels on this machine. If any label is removed or becomes unreadable, **REPLACE** that label before allowing machine to be operated again. Contact us at (360) 734-3482 or www.woodstockint.com to order new labels.

WARRANTY

Woodstock International, Inc. warrants all Shop Fox machinery to be free of defects from workmanship and materials for a period of two years from the date of original purchase by the original owner. This warranty does not apply to defects due directly or indirectly to misuse, abuse, negligence or accidents, lack of maintenance, or reimbursement of third party expenses incurred.

Woodstock International, Inc. will repair, replace, or arrange for a dealer refund, at its expense and option, the Shop Fox machine or machine part proven to be defective for its designed and intended use, provided that the original owner returns the product prepaid to an authorized warranty or repair facility as designated by our Bellingham, Washington office with proof of their purchase of the product within two years, and provides Woodstock International, Inc. reasonable opportunity to verify the alleged defect through inspection. If it is determined there is no defect, or that the defect resulted from causes not within the scope of Woodstock International Inc.'s warranty, then the original owner must bear the cost of storing and returning the product.

This is Woodstock International, Inc.'s sole written warranty and any and all warranties that may be implied by law, including any merchantability or fitness, for any particular purpose, are hereby limited to the duration of this written warranty. We do not warrant that Shop Fox machinery complies with the provisions of any law, acts or electrical codes. We do not reimburse for third party repairs. In no event shall Woodstock International, Inc.'s liability under this limited warranty exceed the purchase price paid for the product, and any legal actions brought against Woodstock International, Inc. shall be tried in the State of Washington, County of Whatcom. We shall in no event be liable for death, injuries to persons or property or for incidental, contingent, special or consequential damages arising from the use of our products.

Every effort has been made to ensure that all Shop Fox machinery meets high quality and durability standards. We are committed to continuously improving the quality of our products, and reserve the right to change specifications at any time.

To register the warranty, go to <https://www.woodstockint.com/warranty>, or scan the QR code below. You will be directed to the Warranty Registration page on www.woodstockint.com. Enter all applicable production information.



High Quality Machines and Tools

Woodstock International, Inc. carries thousands of products designed to meet the needs of today's woodworkers and metalworkers. Ask your dealer about these fine products:



PRO-STIK®
ABRASIVE BELT & DISC CLEANER

BROSNA®
PRECISION STOP BLOCK

PARROT VISE®

THE REBEL®

Aluma-Classic®

STEELEX®
FINE TOOLS

PLANER PAL®

JOINTER PAL®

STEELEX®
PLUS

Rotacator®

slickplane®

ACCU-SHARP®
BOARD BUDDIES®

WHOLESALE ONLY

WOODSTOCK®
INTERNATIONAL INC.

Phone: (360) 734-3482

Fax: (360) 671-3053

Toll Free Fax: (800) 647-8801

P.O. Box 2309, Bellingham, WA 98227

woodstockint.com