

# READ THIS FIRST



## MODEL SB1108/SB1109 \*\*\*IMPORTANT UPDATE\*\*\*



Applies to Models Mfd. Since 11/22  
and Owner's Manual Printed 12/20

The following change was made to this machine since the owner's manual was printed:

- Digital readout bracket and housing changed.

Aside from this information, all other content in the owner's manual applies and **MUST** be read and understood for your own safety. **IMPORTANT: Keep this update with the owner's manual for future reference.**

If you have any further questions about this manual update or the changes made to the machine, contact our Technical Support at (360) 734-1540 or email [www.southbendtools.com](http://www.southbendtools.com).

### Revised Parts

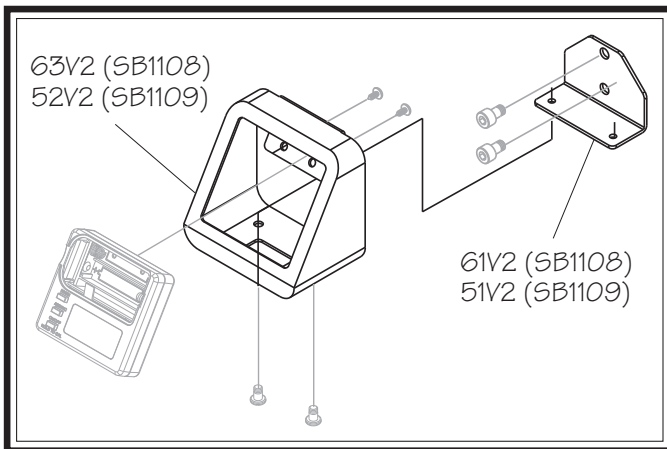

### Old DRO Housing



### SB1108

REF	PART #	DESCRIPTION
61V2	PSB1108061V2	DIGITAL READOUT BRACKET V2.11.22
63V2	PSB1108063V2	DIGITAL READOUT HOUSING V2.11.22

### SB1109

REF	PART #	DESCRIPTION
51V2	PSB1109051V2	DIGITAL READOUT BRACKET V2.11.22
52V2	PSB1109052V2	DIGITAL READOUT HOUSING V2.11.22

### New DRO Housing



Copyright © September, 2022 by South Bend Tools  
**WARNING: No portion of this manual may be reproduced without written approval.**  
**#JP22475 Printed in Taiwan**

# READ THIS FIRST



## MODEL SB1108/SB1109 \*\*\*IMPORTANT UPDATE\*\*\*



Applies to Models Mfd. Since 07/22  
and Owner's Manual Printed 12/20

The following change was made to this machine since the owner's manual was printed:

- Control panel and pedestal have been modified.

Aside from this information, all other content in the owner's manual applies and **MUST** be read and understood for your own safety. **IMPORTANT: Keep this update with the owner's manual for future reference.**

If you have any further questions about this manual update or the changes made to the machine, contact our Technical Support at (360) 734-1540 or email [www.southbendtools.com](http://www.southbendtools.com).

### SB1108 Revised Parts

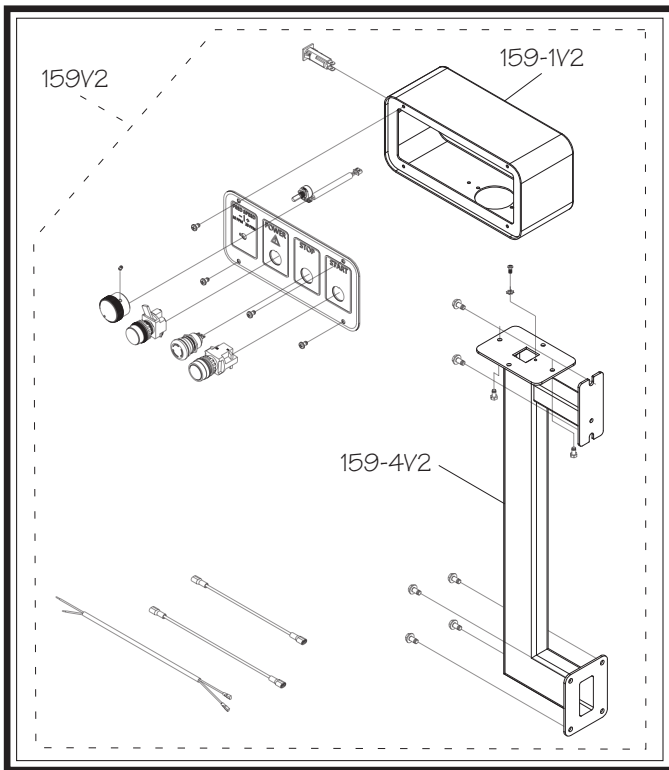

### SB1109 Revised Parts

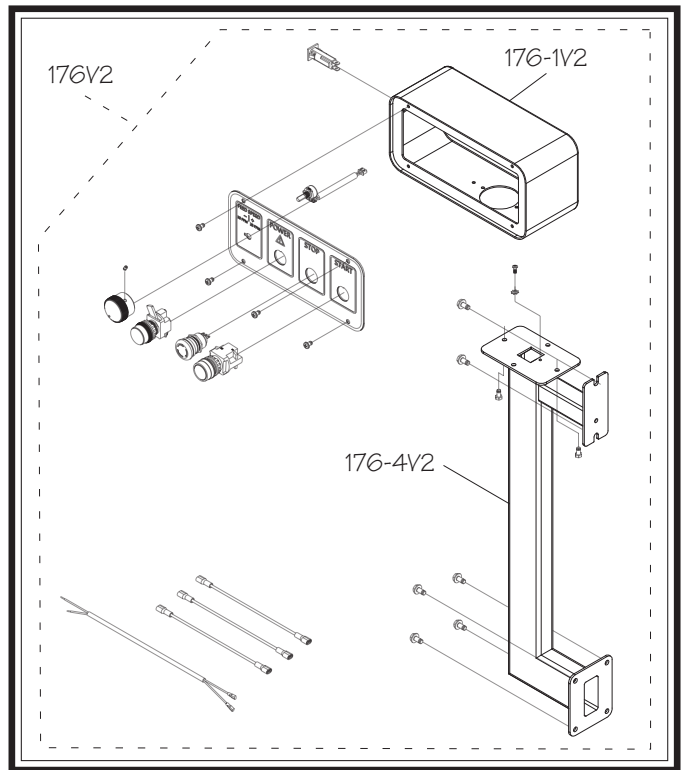

REF	PART #	DESCRIPTION
159V2	PSB1108159V2	CONTROL PANEL ASSEMBLY V2.07.22
159-1V2	PSB1108159-1V2	CONTROL PANEL BOX V2.07.22
159-4V2	PSB1108159-4V2	CONTROL PANEL PEDESTAL V2.07.22

REF	PART #	DESCRIPTION
176V2	PSB1109176V2	CONTROL PANEL ASSEMBLY V2.07.22
176-1V2	PSB1109176-1V2	CONTROL PANEL BOX V2.07.22
176-4V2	PSB1109176-4V2	SWITCH PEDESTAL V2.07.22



Copyright © June, 2022 by South Bend Tools  
**WARNING: No portion of this manual may be reproduced without written approval.**  
**#MN22381 Printed in Taiwan**

# 15" & 20" PLANER w/HELICAL CUTTERHEAD MODEL SB1108/SB1109



**OWNER'S MANUAL**

# South Bend Tools®

*A Tradition of Excellence*

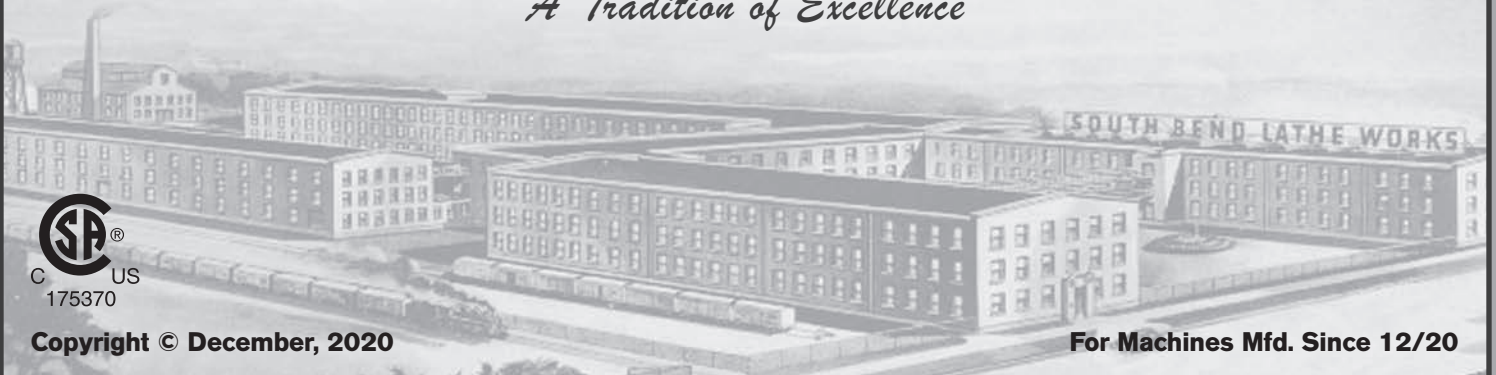

Copyright © December, 2020

For Machines Mfd. Since 12/20

# Scope of Manual

This manual helps the reader understand the machine, how to prepare it for operation, how to control it during operation, and how to keep it in good working condition. We assume the reader has a basic understanding of how to operate this type of machine, but that the reader is not familiar with the controls and adjustments of this specific model. As with all machinery of this nature, learning the nuances of operation is a process that happens through training and experience. If you are not an experienced operator of this type of machinery, read through this entire manual, then learn more from an experienced operator, schooling, or research before attempting operations. Following this advice will help you avoid serious personal injury and get the best results from your work.

# Manual Feedback

We've made every effort to be accurate when documenting this machine. However, errors sometimes happen or the machine design changes after the documentation process—so the manual may not exactly match your machine. If a difference between the manual and machine leaves you in doubt, contact our customer service for clarification.

We highly value customer feedback on our manuals. If you have a moment, please share your experience using this manual. What did you like about it? Is there anything you would change to make it better? Did it meet your expectations for clarity, professionalism, and ease-of-use?

**South Bend Tools**  
**c/o Technical Documentation Manager**  
**P.O. Box 2027**  
**Bellingham, WA 98227**  
**Email: [manuals@southbendtools.com](mailto:manuals@southbendtools.com)**

# Updates

For your convenience, any updates to this manual will be available to download free of charge through our website at:

**[www.southbendtools.com](http://www.southbendtools.com)**

# Customer Service

We stand behind our machines. If you have any service questions, parts requests or general questions about your purchase, feel free to contact us.

**South Bend Tools**  
**P.O. Box 2027**  
**Bellingham, WA 98227**  
**Phone: (360) 734-1540**  
**Fax: (360) 676-1075 (International)**  
**Fax: (360) 734-1639 (USA Only)**  
**Email: [sales@southbendtools.com](mailto:sales@southbendtools.com)**



# Table of Contents

<b>INTRODUCTION.....</b>	<b>2</b>	<b>MAINTENANCE .....</b>	<b>34</b>
Identification .....	2	Maintenance Schedule.....	34
Description of Controls & Components .....	3	Cleaning & Protecting .....	34
Internal Components.....	4	Machine Storage .....	34
Product Specifications SB1108.....	5	Lubrication .....	35
Product Specifications SB1109.....	7	Anti-Kickback Fingers.....	37
<b>SAFETY.....</b>	<b>9</b>	<b>SERVICE.....</b>	<b>38</b>
Understanding Risks of Machinery .....	9	Tensioning/Replacing V-Belts .....	38
Basic Machine Safety .....	9	Setting Feed Roller, Chip Breaker & Pressure	
Additional Planer Safety .....	11	Bar Heights .....	39
<b>PREPARATION .....</b>	<b>12</b>	Adjusting Feed-Roller Spring Tension .....	42
Preparation Overview.....	12	Positioning Chip Deflector.....	42
Required for Setup.....	12	Calibrating Table Height Scale.....	43
Power Supply Requirements .....	13	Replacing Feed Motor Brushes .....	43
Unpacking .....	15	Checking Pulley Alignment.....	44
Inventory .....	15	Tensioning Table Height Chain .....	44
Cleaning & Protecting .....	17	Adjusting Table Parallelism.....	45
Location .....	18	<b>TROUBLESHOOTING .....</b>	<b>47</b>
Lifting & Moving.....	19	<b>ELECTRICAL.....</b>	<b>50</b>
Assembly .....	19	Electrical Safety Instructions .....	50
Dust Collection.....	21	SB1108 Wiring Diagram .....	51
Checking Gearbox Oil Level.....	22	SB1108 Electrical Component Photos .....	52
Test Run .....	22	SB1108 Height DRO Wiring Diagram.....	53
Inspections & Adjustments .....	23	SB1109 Wiring Diagram .....	54
<b>OPERATION.....</b>	<b>24</b>	SB1109 Electrical Component Photos .....	55
Operation Overview.....	24	SB1109 Height DRO Wiring Diagram.....	56
Stock Inspection & Requirements.....	25	<b>PARTS.....</b>	<b>57</b>
Wood Types .....	25	SB1108 Main .....	57
Planing Tips .....	26	SB1108 Table & Base .....	60
Common Cutting Problems .....	26	SB1108 Stand & Motor.....	62
Depth of Cut.....	28	SB1108 Labels & Cosmetics.....	64
Setting Feed Rate .....	28	SB1109 Main.....	65
Bed Roller Height .....	29	SB1109 Table & Base .....	68
Rotating/Replacing Cutterhead Inserts.....	30	SB1109 Stand & Motor.....	70
Digital Readout.....	31	SB1109 Labels & Cosmetics.....	72
<b>ACCESSORIES.....</b>	<b>32</b>	<b>WARRANTY.....</b>	<b>73</b>

# Identification

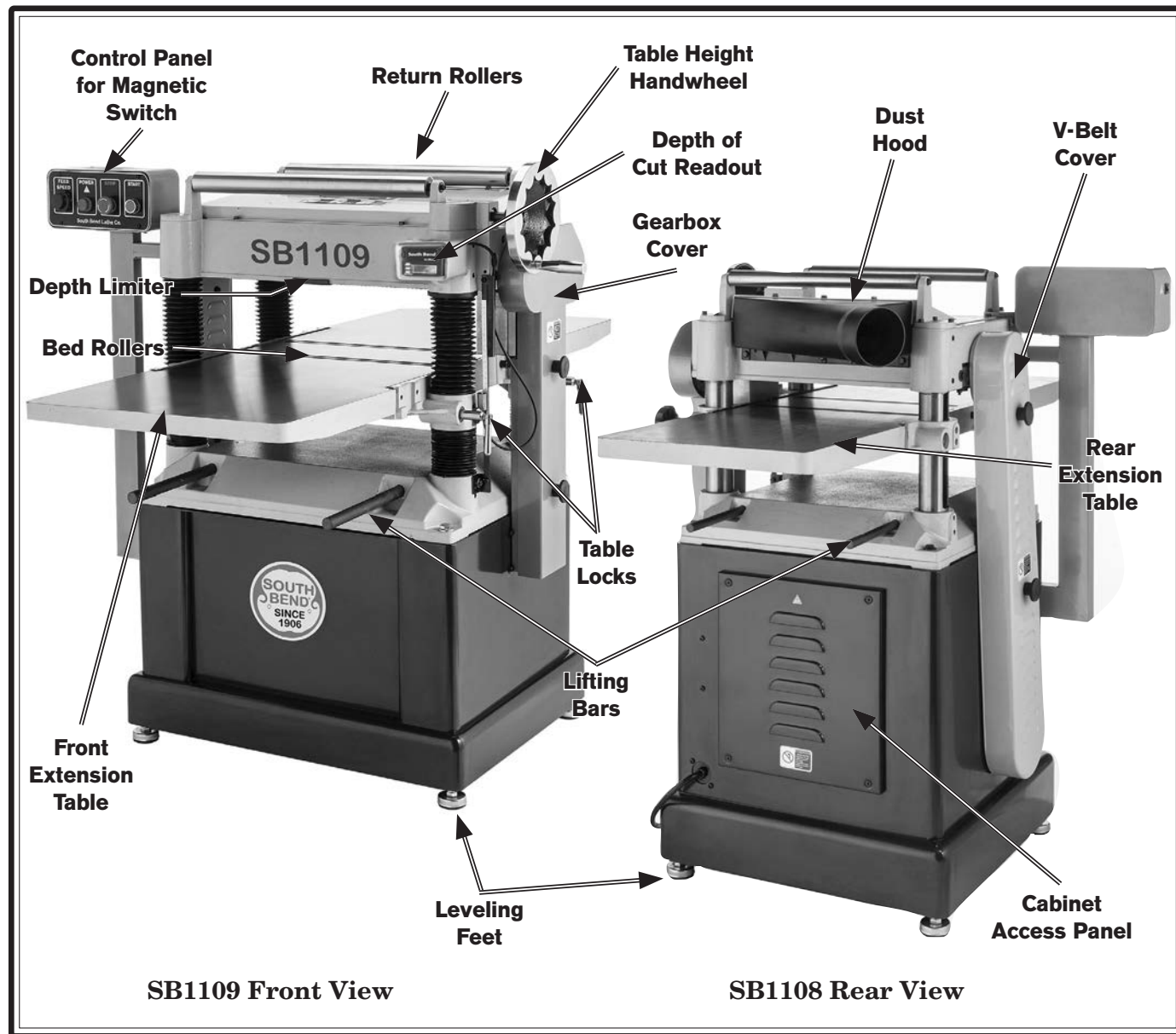

SB1109 Front View

SB1108 Rear View

## **!WARNING**

Serious personal injury could occur if you connect the machine to power before completing the setup process. **DO NOT** connect power until instructed to do so later in this manual.

## **!WARNING**

Untrained users have an increased risk of seriously injuring themselves with this machine. Do not operate this machine until you have understood this entire manual and received proper training.

# Description of Controls & Components

Refer to **Figures 1–2** and the following descriptions to become familiar with the basic controls and components used to operate this machine.

## Control Panel

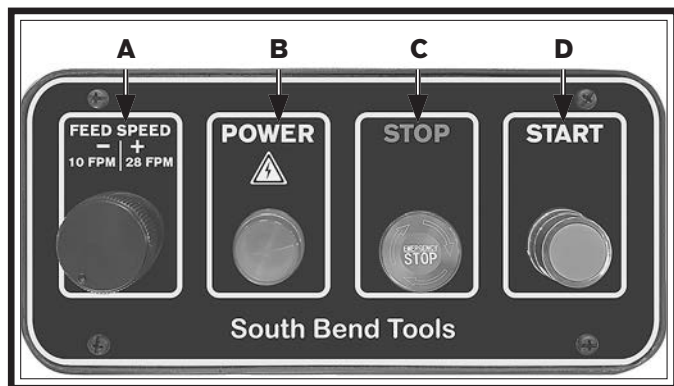

**Figure 1. Control panel.**

- A. Feed Speed Control Knob:** Controls the workpiece speed (feed rate). Turn clockwise to increase feed rate; turn counter-clockwise to reduce feed rate.
- B. Power Indicator Light:** Illuminates when power is present at control panel.
- C. EMERGENCY STOP Button:** Stops machine when pressed. Rotate button clockwise until it pops out to reset.
- D. START Button:** Starts cutterhead and feed rollers.

## Operation Controls

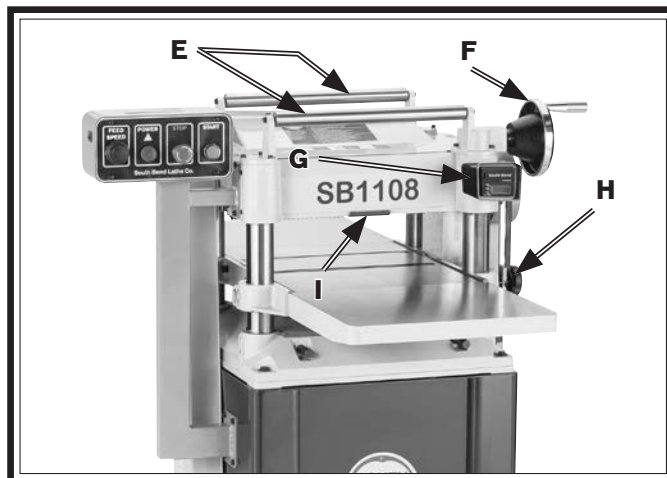

**Figure 2. Operation controls.**

- E. Return Rollers:** Assist sliding workpiece back to feed side of planer after planing pass.
- F. Table Height Handwheel:** Raises and lowers table to accommodate different workpiece thicknesses. One complete revolution moves the table approximately  $\frac{1}{16}$ ".
- G. Depth of Cut Digital Readout:** Displays current table height.
- H. Table Locks:** Secure table height position.
- I. Depth Limiter:** Limits maximum depth of cut.  
SB1108:  $\frac{3}{32}$ " at full width.  
SB1109:  $\frac{5}{64}$ " at full width.

# Internal Components

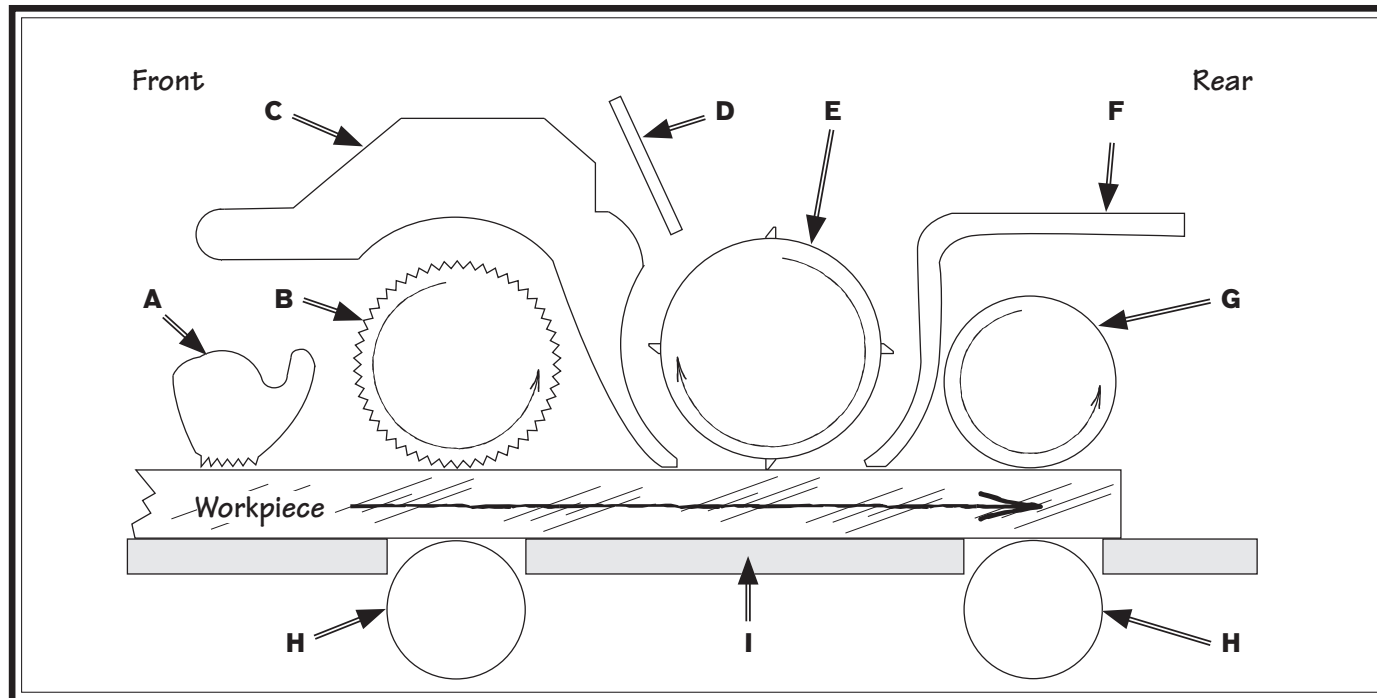

Figure 3. Workpiece path and major planing components (side cutaway view).

- A. Anti-Kickback Fingers:** Provide additional safety for the operator.
- B. Serrated Infeed Roller:** Pulls the workpiece toward the cutterhead.
- C. Chip Breaker:** Breaks off chips created by the cutterhead to prevent tear-out and diverts the chips to the dust hood.
- D. Chip Deflector:** Directs chips into the dust hood.
- E. Cutterhead:** Holds the knives/indexable carbide inserts that remove material from the workpiece.
- F. Pressure Bar:** Stabilizes the workpiece as it leaves the cutterhead and assists in deflecting wood particles toward the dust hood.
- G. Outfeed Roller:** Pulls the workpiece through the planer.
- H. Bed Rollers:** Provide upward pressure on the workpiece, enabling the feed rollers to pull the workpiece along.
- I. Planer Table:** Provides a smooth and level path for the workpiece as it moves through the planer.

## ⚠️ WARNING

Like all machinery there is potential danger when operating this machine. Accidents are frequently caused by lack of familiarity or failure to pay attention. Use this machine with respect and caution to decrease the risk of operator injury. If normal safety precautions are overlooked or ignored, serious personal injury may occur.





## Model SB1108 15" Planer with Helical Cutterhead

**Product Dimensions**

Weight..... 509 lbs.  
 Width (side-to-side) x Depth (front-to-back) x Height..... 39 x 48 x 44-1/2 in.  
 Footprint (Length x Width)..... 23 x 22-1/2 in.

**Shipping Dimensions**

Type..... Wood Crate  
 Content..... Machine  
 Weight..... 595 lbs.  
 Length x Width x Height..... 27 x 37 x 52 in.  
 Must Ship Upright..... Yes

**Electrical**

Power Requirement..... 230V, Single-Phase, 60 Hz  
 Full-Load Current Rating..... 18A  
 Minimum Circuit Size..... 20A  
 Connection Type..... Cord & Plug  
 Power Cord Included..... Yes  
 Power Cord Length..... 120 in.  
 Power Cord Gauge..... 12 AWG  
 Plug Included..... Yes  
 Included Plug Type..... 6-20  
 Switch Type..... Magnetic Switch w/Thermal Overload Protection

**Motors**

**Main**

Horsepower..... 3 HP  
 Phase..... Single-Phase  
 Amps..... 12A  
 Speed..... 3450 RPM  
 Type..... TEFC Capacitor-Start Induction  
 Power Transfer ..... Triple V-Belt  
 Bearings..... Sealed & Permanently Lubricated  
 Centrifugal Switch/Contacts Type..... External

**Feed**

Horsepower..... 3/4 HP  
 Amps..... 8A  
 Speed..... 2500 RPM  
 Type..... DC Motor  
 Power Transfer ..... Belt & Chain  
 Bearings..... Sealed & Permanently Lubricated

**Main Specifications****Main Specifications**

Planer Size.....	15 in.
Max. Cut Width.....	15 in.
Max. Cut Height.....	6 in.
Min. Stock Length.....	6 in.
Min. Stock Thickness.....	3/16 in.
Number of Cuts Per Inch.....	167 - 60
Number of Cuts Per Minute.....	20,000
Cutterhead Speed.....	5000 RPM
Planing Feed Rate.....	10 - 28 FPM
Max. Cut Depth Planing Full Width.....	3/32 in.
Max. Cut Depth Planing 6-Inch Wide Board.....	1/8 in.

**Cutterhead Info**

Cutterhead Type.....	Helical
Cutterhead Diameter .....	3 in.
Number of Cutter Rows.....	4
Number of Indexable Cutters.....	52
Cutter Insert Type.....	Indexable Carbide
Cutter Insert Size Length.....	15mm
Cutter Insert Size Width.....	15mm
Cutter Insert Size Thickness.....	2.5mm

**Table Info**

Table/Headstock Movement.....	6 in.
Table Bed Size Length.....	48 in.
Table Bed Size Width.....	15 in.
Table Bed Size Thickness.....	2 in.
Number of Bed Rollers.....	2
Floor-to-Table Height.....	30 - 36 in.
Table Wings Size Length.....	14 in.
Table Wings Size Width.....	15-1/16 in.

**Construction**

Table.....	Precision-Ground Cast Iron
Body.....	Cast Iron
Stand.....	Steel
Cutterhead Assembly.....	Steel
Infeed Roller.....	Serrated Steel
Outfeed Roller.....	Smooth Steel
Paint Type/Finish.....	Powder Coated

**Other**

Table/Headstock Locks.....	Yes
Measurement Scale.....	Inch & Metric
Number of Dust Ports.....	1
Dust Port Size.....	4 in.
Mobile Base.....	T28000

**Other**

Country of Origin .....	Taiwan
Warranty .....	1 Year
Approximate Assembly & Setup Time .....	1 Hour
Serial Number Location .....	ID Label
Certified by a Nationally Recognized Testing Laboratory (NRTL) .....	Yes



## Model SB1109

### 20" Planer with Helical Cutterhead

#### Product Dimensions

Weight..... 719 lbs.  
 Width (side-to-side) x Depth (front-to-back) x Height..... 46-1/2 x 56 x 46 in.  
 Footprint (Length x Width)..... 23-1/2 x 29-1/2 in.

#### Shipping Dimensions

Type..... Wood Crate  
 Content..... Machine  
 Weight..... 820 lbs.  
 Length x Width x Height..... 42 x 30 x 52 in.  
 Must Ship Upright..... Yes

#### Electrical

Power Requirement..... 220V, Single-Phase, 60 Hz  
 Full-Load Current Rating..... 27A  
 Minimum Circuit Size..... 30A  
 Connection Type..... Cord & Plug  
 Power Cord Included..... Yes  
 Power Cord Length..... 120 in.  
 Power Cord Gauge..... 12 AWG  
 Plug Included..... Yes  
 Included Plug Type..... L6-30  
 Switch Type..... Magnetic Switch w/Thermal Overload Protection

#### Motors

##### Main

Horsepower..... 5 HP  
 Phase..... Single-Phase  
 Amps..... 23A  
 Speed..... 3450 RPM  
 Type..... TEFC Capacitor-Start Induction  
 Power Transfer ..... Triple V-Belt  
 Bearings..... Sealed & Permanently Lubricated  
 Centrifugal Switch/Contacts Type..... External

##### Feed

Horsepower..... 3/4 HP  
 Amps..... 8A  
 Speed..... 2500 RPM  
 Type..... DC Motor  
 Power Transfer ..... Belt & Chain  
 Bearings..... Sealed & Permanently Lubricated

**Main Specifications**

**Main Specifications**

Planer Size.....	20 in.
Max. Cut Width.....	20 in.
Max. Cut Height.....	8 in.
Min. Stock Length.....	7 in.
Min. Stock Thickness.....	1/4 in.
Number of Cuts Per Inch.....	167 - 60
Number of Cuts Per Minute.....	20,000
Cutterhead Speed.....	5000 RPM
Planing Feed Rate.....	10 - 28 FPM
Max. Cut Depth Planing Full Width.....	5/64 in.
Max. Cut Depth Planing 6-Inch Wide Board.....	1/8 in.

**Cutterhead Info**

Cutterhead Type.....	Helical
Cutterhead Diameter .....	3-1/4 in.
Number of Cutter Rows.....	4
Number of Indexable Cutters.....	92
Cutter Insert Type.....	Indexable Carbide
Cutter Insert Size Length.....	15mm
Cutter Insert Size Width.....	15mm
Cutter Insert Size Thickness.....	2.5mm

**Table Info**

Table/Headstock Movement.....	8 in.
Table Bed Size Length.....	56 in.
Table Bed Size Width.....	20 in.
Table Bed Size Thickness.....	2-1/4 in.
Number of Bed Rollers.....	2
Floor-to-Table Height.....	28 - 36 in.
Table Wings Size Length.....	15 in.
Table Wings Size Width.....	21-1/4 in.

**Construction**

Table.....	Precision-Ground Cast Iron
Body.....	Cast Iron
Stand.....	Steel
Cutterhead Assembly.....	Steel
Infeed Roller.....	Serrated Steel
Outfeed Roller.....	Smooth Steel
Paint Type/Finish.....	Powder Coated

**Other**

Table/Headstock Locks.....	Yes
Measurement Scale.....	Inch & Metric
Number of Dust Ports.....	1
Dust Port Size.....	5 in.
Mobile Base.....	T28000

**Other**

Country of Origin .....	Taiwan
Warranty .....	2 Years
Approximate Assembly & Setup Time .....	1 Hour
Serial Number Location .....	ID Label
Certified by a Nationally Recognized Testing Laboratory (NRTL) .....	Yes



# Understanding Risks of Machinery

Operating all machinery and machining equipment can be dangerous or relatively safe depending on how it is installed and maintained, and the operator's experience, common sense, risk awareness, working conditions, and use of personal protective equipment (safety glasses, respirators, etc.).

The owner of this machinery or equipment is ultimately responsible for its safe use. This responsibility includes proper installation in a safe environment, personnel training and usage authorization, regular inspection and maintenance, manual availability and comprehension, application of safety devices, integrity of cutting tools or accessories, and the usage of approved personal protective equipment by all operators and bystanders.

The manufacturer of this machinery or equipment will not be held liable for injury or property damage from negligence, improper training, machine modifications, or misuse. Failure to read, understand, and follow the manual and safety labels may result in serious personal injury, including amputation, broken bones, electrocution, or death.

The signals used in this manual to identify hazard levels are as follows:



*Death or catastrophic harm WILL occur.*



*Moderate injury or fire MAY occur.*



*Death or catastrophic harm COULD occur.*



*Machine or property damage may occur.*

## Basic Machine Safety

**Owner's Manual:** All machinery and machining equipment presents serious injury hazards to untrained users. To reduce the risk of injury, anyone who uses THIS item MUST read and understand this entire manual before starting.

**Personal Protective Equipment:** Operating or servicing this item may expose the user to flying debris, dust, smoke, dangerous chemicals, or loud noises. These hazards can result in eye injury, blindness, long-term respiratory damage, poisoning, cancer, reproductive harm or hearing loss. Reduce your risks from these hazards by wearing approved eye protection, respirator, gloves, or hearing protection.

**Trained/Supervised Operators Only:** Untrained users can seriously injure themselves or bystanders. Only allow trained and properly supervised personnel to operate this item. Make sure safe operation instructions are clearly understood. If electrically powered, use padlocks and master switches, and remove start switch keys to prevent unauthorized use or accidental starting.

**Guards/Covers:** Accidental contact with moving parts during operation may cause severe entanglement, impact, cutting, or crushing injuries. Reduce this risk by keeping any included guards/covers/doors installed, fully functional, and positioned for maximum protection.

**Entanglement:** Loose clothing, gloves, neckties, jewelry or long hair may get caught in moving parts, causing entanglement, amputation, crushing, or strangulation. Reduce this risk by removing/securing these items so they cannot contact moving parts.

**Mental Alertness:** Operating this item with reduced mental alertness increases the risk of accidental injury. Do not let a temporary influence or distraction lead to a permanent disability! Never operate when under the influence of drugs/alcohol, when tired, or otherwise distracted.

**Safe Environment:** Operating electrically powered equipment in a wet environment may result in electrocution; operating near highly flammable materials may result in a fire or explosion. Only operate this item in a dry location that is free from flammable materials.

**Electrical Connection:** With electrically powered equipment, improper connections to the power source may result in electrocution or fire. Always adhere to all electrical requirements and applicable codes when connecting to the power source. Have all work inspected by a qualified electrician to minimize risk.

**Disconnect Power:** Adjusting or servicing electrically powered equipment while it is connected to the power source greatly increases the risk of injury from accidental startup. Always disconnect power **BEFORE** any service or adjustments, including changing blades or other tooling.

**Secure Workpiece/Tooling:** Loose workpieces, cutting tools, or rotating spindles can become dangerous projectiles if not secured or if they hit another object during operation. Reduce the risk of this hazard by verifying that all fastening devices are properly secured and items attached to spindles have enough clearance to safely rotate.

**Chuck Keys or Adjusting Tools:** Tools used to adjust spindles, chucks, or any moving/rotating parts will become dangerous projectiles if left in place when the machine is started. Reduce this risk by developing the habit of always removing these tools immediately after using them.

**Work Area:** Clutter and dark shadows increase the risks of accidental injury. Only operate this item in a clean, non-glaring, and well-lighted work area.

**Properly Functioning Equipment:** Poorly maintained, damaged, or malfunctioning equipment has higher risks of causing serious personal injury compared to those that are properly maintained. To reduce this risk, always maintain this item to the highest standards and promptly repair/service a damaged or malfunctioning component. Always follow the maintenance instructions included in this documentation.

**Unattended Operation:** Electrically powered equipment that is left unattended while running cannot be controlled and is dangerous to bystanders. Always turn the power **OFF** before walking away.

**Health Hazards:** Certain cutting fluids and lubricants, or dust/smoke created when cutting, may contain chemicals known to the State of California to cause cancer, respiratory problems, birth defects, or other reproductive harm. Minimize exposure to these chemicals by wearing approved personal protective equipment and operating in a well ventilated area.

**Difficult Operations:** Attempting difficult operations with which you are unfamiliar increases the risk of injury. If you experience difficulties performing the intended operation, **STOP!** Seek an alternative method to accomplish the same task, ask a qualified expert how the operation should be performed, or contact our Technical Support for assistance.

# Additional Planer Safety

## ⚠️ WARNING

**Amputation, serious cuts, entanglement, or death can occur from contact with rotating cutterhead or other moving parts! Flying chips can cause eye injuries or blindness. Workpieces or knives thrown by cutterhead can strike nearby operator or bystanders with deadly force. To reduce the risk of these hazards, operator and bystanders MUST completely heed hazards and warnings below.**

**Kickback:** Know how to reduce the risk of kickback and kickback-related injuries. “Kickback” occurs during the operation when the workpiece is ejected back from the infeed side of the machine at a high rate of speed. Kickback is commonly caused by poor workpiece selection, unsafe feeding techniques, or improper machine setup/maintenance. Kickback injuries typically occur as follows: (1) operator/bystanders are struck by the workpiece, resulting in impact injuries (i.e., blindness, broken bones, bruises, death); (2) operator’s hands are pulled into the machine from the outfeed side, resulting in amputation or severe lacerations.

**Avoid Contact with Moving Parts:** Never remove guards/covers or reach inside the planer during operation or while connected to power. You could be seriously injured if you accidentally touch the spinning cutterhead or get entangled in moving parts. If a workpiece becomes stuck or sawdust removal is necessary, turn planer **OFF**, allow cutterhead to stop, and disconnect power before clearing.

**Dull/Damaged Knives/Inserts:** Only use sharp, undamaged knives/inserts. Dull or damaged knives/inserts increase the risk of kickback.

**Inspecting Stock:** To reduce the risk of kickback injuries or machine damage, thoroughly inspect and prepare the workpiece before cutting. Verify workpiece is free of nails, staples, loose knots, or foreign material. Workpieces with minor warping should be jointed first or planed with the cupped side facing the table.

**Body Placement:** Stand to one side of planer during the entire operation to avoid getting hit if kickback occurs.

**Grain Direction:** Planing across the grain is hard on the planer and may cause kickback. Plane in the same direction or at a slight angle with the wood grain.

**Planing Correct Material:** Only plane natural wood stock with this planer. **DO NOT** plane MDF, OSB, plywood, laminates or other synthetic materials that can break up inside the planer and be ejected towards the operator.

**Looking Inside Planer:** Wood chips fly around inside the planer at a high rate of speed during operation. To avoid injury from flying material, **DO NOT** look inside planer during operation.

**Cutting Limitations:** To reduce the risk of kickback hazards or damage to the machine, do not exceed the maximum depth of cut or minimum board length and thickness found in the **Data Sheet**. Only feed one board at a time.

**Infeed Roller Clearance:** The infeed roller is designed to pull material into the spinning cutterhead. To reduce the risk of entanglement, keep hands, clothing, jewelry, and long hair away from the infeed roller during operation.

**Feed Workpiece Properly:** To reduce the risk of kickback, never start planer with workpiece touching cutterhead. Allow cutterhead to reach full speed before feeding, and do not change feed speed during cutting operation.

**Workpiece Support:** To reduce the risk of kickback, always make sure workpiece can move completely across table without rocking or tipping. Use auxiliary support stands for long stock.

**Secure Knives/Inserts:** Loose knives or improperly set inserts can become dangerous projectiles or cause machine damage. Always verify knives/inserts are secure and properly adjusted before operation.

## Preparation Overview

The purpose of the preparation section is to help you prepare your machine for operation. The list below outlines the basic process. Specific steps for each of these points will be covered in detail later in this section.

### **The typical preparation process is as follows:**

1. Unpack the machine and inventory the contents of the box/crate.
2. Clean the machine and its components.
3. Identify an acceptable location for the machine and move it to that location.
4. Level the machine using the pre-installed machine mounts.
5. Assemble the loose components and make any necessary adjustments or inspections to ensure the machine is ready for operation.
6. Connect the machine to the power source.
7. Test run the machine to make sure it functions properly and is ready for operation.

## Required for Setup

The items listed below are required to successfully set up and prepare this machine for operation.

### **For Lifting**

- A forklift or other power lifting device rated for the weight of the machine.
- Lifting Strap or Chain (rated for at least 1000 lbs.)

### **For Power Connection**

- A power source that meets the minimum circuit requirements for this machine. (Refer to the **Power Supply Requirements** on **Page 13** for details.)

### **For Assembly**

- Safety Glasses (for each person)
- Straightedge 4' (or longer)
- Dust Collection System
- 4" Dust Hose (for SB1108)
- 4" Hose Clamp (for SB1108)
- 5" Dust Hose (for SB1109)
- 5" Hose Clamp (for SB1109)
- Disposable Rags
- Disposable Gloves
- Cleaner/Degreaser
- Gearbox Oil
- Phillips Head Screwdriver #2
- Open-End Wrench 8mm (for SB1108)
- Open-End Wrench 17mm (for SB1109)



# Power Supply Requirements

## Availability

Before installing the machine, consider the availability and proximity of the required power supply circuit. If an existing circuit does not meet the requirements for this machine, a new circuit must be installed.

To minimize the risk of electrocution, fire, or equipment damage, installation work and electrical wiring must be done by an electrician or qualified service personnel in accordance with applicable electrical codes and safety standards.

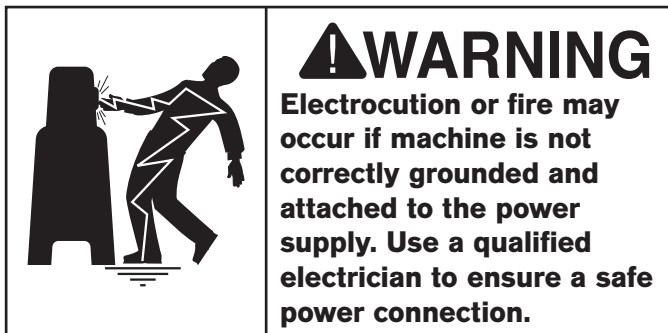

## Full-Load Current Rating at 220V

The full-load current rating is the amperage a machine draws at 100% of the rated output power. On machines with multiple motors, this is the amperage drawn by the largest motor or sum of all motors and electrical devices that might operate at one time during normal operations.

**SB1108 Full-Load Rating ..... 18 Amps**  
**SB1109 Full-Load Rating ..... 27 Amps**

The full-load current is not the maximum amount of amps that the machine will draw. If the machine is overloaded, it will draw additional amps beyond the full-load rating.

If the machine is overloaded for a sufficient length of time, damage, overheating, or fire may result—especially if connected to an undersized circuit. To reduce the risk of these hazards, avoid overloading the machine during operation and make sure it is connected to a power supply circuit that meets the requirements in the following section.

## Circuit Information

A power supply circuit includes all electrical equipment between the main breaker box or fuse panel in your building and the incoming power connections inside the machine. This circuit must be safely sized to handle the full-load current that may be drawn from the machine for an extended period of time. (If this machine is connected to a circuit protected by fuses, use a time delay fuse marked D.)

**Note:** The circuit requirements in this manual are for a dedicated circuit—where only one machine will be running at a time. If this machine will be connected to a shared circuit where multiple machines will be running at the same time, consult a qualified electrician to ensure the circuit is properly sized.



## Grounding Requirements

This machine must be grounded! In the event of certain types of malfunctions or breakdowns, grounding provides a path of least resistance for electric current in order to reduce the risk of electric shock.

Improper connection of the equipment-grounding wire can result in a risk of electric shock. The wire with green insulation (with or without yellow stripes) is the equipment-grounding wire. If repair or replacement of the power cord or plug is necessary, do not connect the equipment-grounding wire to a live (current carrying) terminal.

Check with an electrician or qualified service personnel if you do not understand these grounding requirements, or if you are in doubt about whether the tool is properly grounded.

If you ever notice that a cord or plug is damaged or worn, disconnect it from power, and immediately replace it with a new one.

### SB1108 Circuit Requirements

This machine is prewired to operate on a power supply circuit that has a verified ground and meets the following requirements:

**Nominal Voltage** ..... 208V, 220V, 230V, 240V  
**Cycle** .....60 Hz  
**Phase** .....Single-Phase  
**Circuit Rating**..... 20 Amps  
**Plug/Receptacle (included)** .....NEMA 6-20

This machine is equipped with a power cord that has an equipment-grounding wire and a grounding plug (similar to the figure below). The plug must only be inserted into a matching receptacle (outlet) that is properly installed and grounded in accordance with all local codes and ordinances.

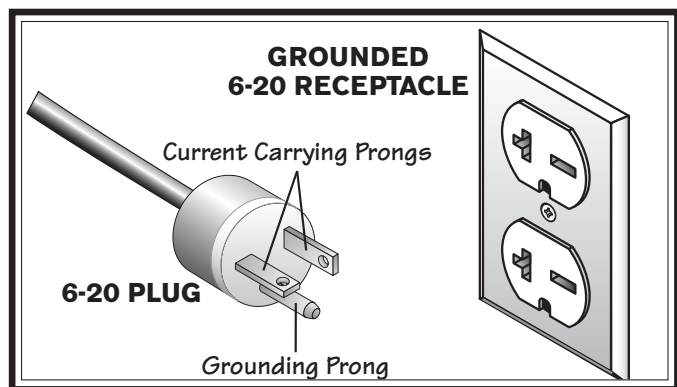

Figure 4. NEMA 6-20 plug and receptacle.

### SB1109 Circuit Requirements

This machine is prewired to operate on a power supply circuit that has a verified ground and meets the following requirements:

**Nominal Voltage** ..... 208V, 220V, 230V, 240V  
**Cycle** .....60 Hz  
**Phase** .....Single-Phase  
**Circuit Rating**..... 30 Amps  
**Plug/Receptacle (included)** .....NEMA L6-30

This machine is equipped with a power cord that has an equipment-grounding wire and a grounding plug (similar to the figure below). The plug must only be inserted into a matching receptacle (outlet) that is properly installed and grounded in accordance with all local codes and ordinances.

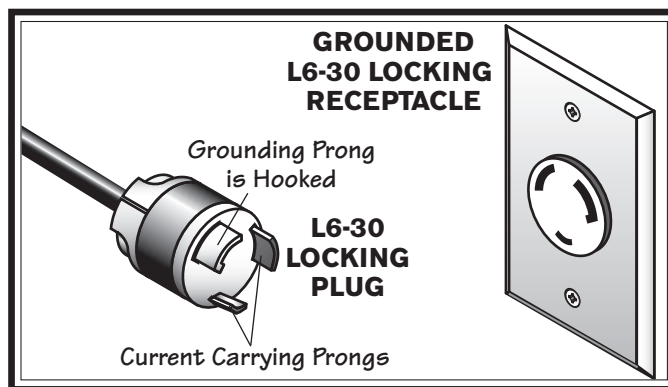

Figure 5. NEMA L6-30 plug and receptacle.

**⚠ CAUTION**

**No adapter should be used with plug. If plug does not fit available receptacle, or if machine must be reconnected for use on a different type of circuit, reconnection must be performed by an electrician or qualified service personnel, and it must comply with all local codes and ordinances.**

### Extension Cords

We do not recommend using an extension cord with this machine. If you must use one, only use it if absolutely necessary and only on a temporary basis.

Extension cords cause voltage drop, which may damage electrical components and shorten motor life. Voltage drop increases as the extension cord size gets longer and the gauge size gets smaller (higher gauge numbers indicate smaller sizes).

Any extension cord used with this machine must contain a ground wire, match the required plug and receptacle listed in the **Circuit Requirements** for the applicable voltage, and meet the following requirements:

**SB1108** ..... 12 AWG, 50 ft or less  
**SB1109** ..... 10 AWG, 50 ft or less

# Unpacking

This item was carefully packaged to prevent damage during transport. If you discover any damage, please immediately call Customer Service at (360) 734-1540 for advice. You may need to file a freight claim, so take pictures and save all the containers and packing materials for possible inspection by the carrier or its agent.

# Inventory

The following is a list of items shipped with your machine. Before beginning setup, lay these items out and inventory them.

If any non-proprietary parts are missing (e.g. a nut or a washer), we will gladly replace them; or for the sake of expediency, replacements can be obtained at your local hardware store.

## SB1108

Wood Crate (Figures 6-8)	Qty
<b>A.</b> Planer Unit (Not Shown).....	1
<b>B.</b> Extension Tables.....	2
<b>C.</b> Dust Hood.....	1
<b>D.</b> Handwheel .....	1
<b>E.</b> Batteries AAA .....	2
<b>F.</b> Flange Bolts M6-1 x 12 (Dust Port) .....	6
<b>G.</b> Machine Key 4 x 4 x 10 (Handwheel) .....	1
<b>H.</b> Direction Label (Handwheel) .....	1
<b>I.</b> Hex Bolts M8-1.25 x 25 (Ext. Table).....	6
<b>J.</b> Flat Washer 10mm (Handwheel).....	1
<b>K.</b> Hex Nut M10-1.25 (Handwheel) .....	1
<b>L.</b> Flat Washers 8mm (Ext. Table).....	6
<b>M.</b> Set Screws M8-1.25 x 12 (Ext. Table).....	6
<b>N.</b> Handwheel Handle .....	1
<b>O.</b> Hex Wrench Set 3, 4, 6mm.....	1 Each
<b>P.</b> Open-End Wrench 10/13mm .....	1
Open-End Wrench 12/14mm .....	1
<b>Q.</b> T-Handle Torx Wrenches T-25 .....	2
<b>R.</b> Flat Head Torx Screws #10-32 x 1/2" .....	10
<b>S.</b> Indexable Carbide Inserts 15 x 15 x 2.5mm.5	

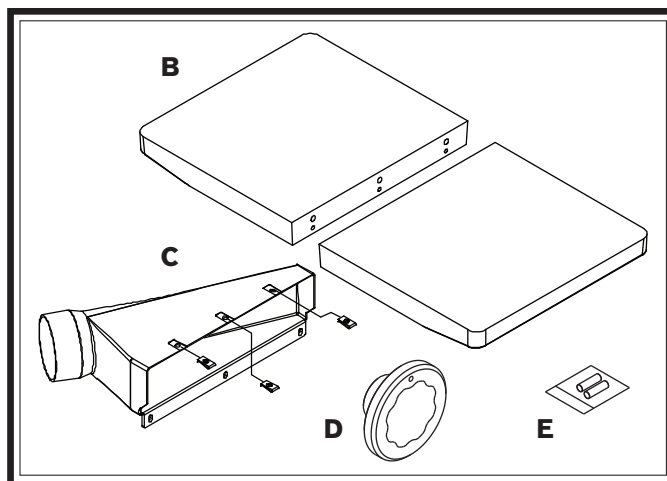

**Figure 6. SB1108 assembly components.**

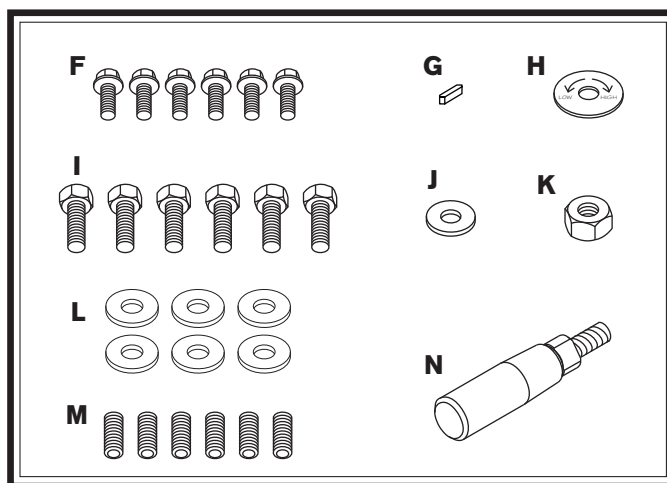

**Figure 7. SB1108 assembly hardware.**

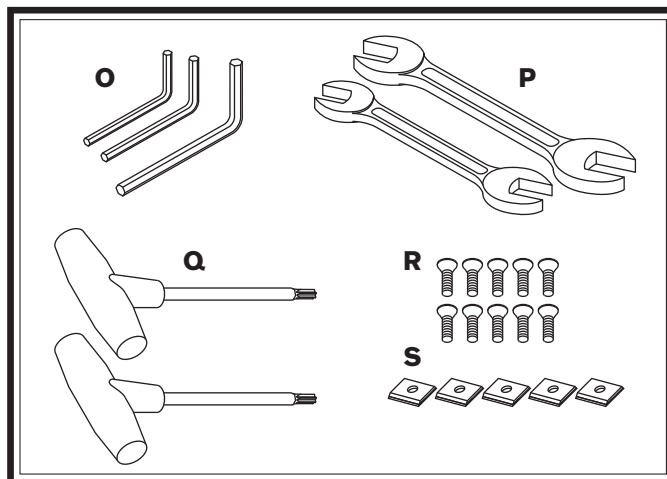
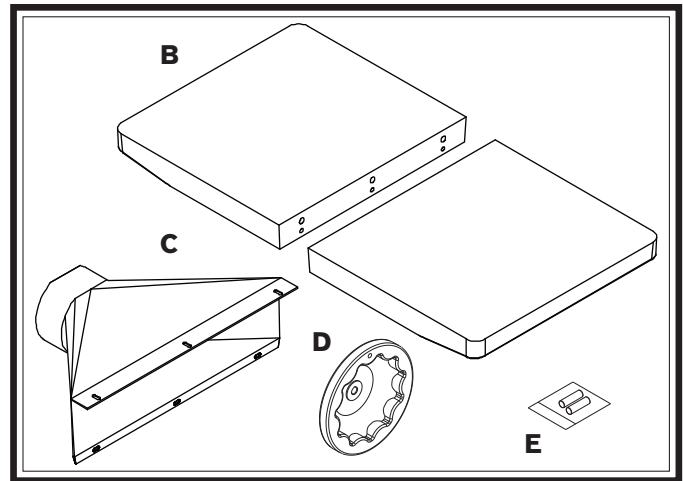

**Figure 8. SB1108 tools and inserts.**

**SB1109**

**Wood Crate (Figures 9-11)**

	<b>Qty</b>
<b>A.</b> Planer Unit (Not Shown).....	1
<b>B.</b> Extension Tables.....	2
<b>C.</b> Dust Hood.....	1
<b>D.</b> Handwheel .....	1
<b>E.</b> Batteries AAA .....	2
<b>F.</b> Flange Bolts M6-1 x 12 (Dust Hood).....	6
<b>G.</b> Machine Key 4 x 4 x 10 (Handwheel) .....	1
<b>H.</b> Direction Label (Handwheel) .....	1
<b>I.</b> Hex Bolts M8-1.25 x 25 (Ext. Table).....	6
<b>J.</b> Flat Washer 10mm (Handwheel).....	1
<b>K.</b> Hex Nut M10-1.25 (Handwheel) .....	1
<b>L.</b> Flat Washers 8mm (Ext. Table).....	6
<b>M.</b> Set Screws M8-1.25 x 12 (Ext. Table).....	6
<b>N.</b> Handwheel Handle .....	1
<b>O.</b> Hex Wrench Set 3-6mm .....	1 Each
<b>P.</b> Open-End Wrench 8/10mm .....	1
Open-End Wrench 10/13mm .....	1
Open-End Wrench 12/14mm .....	1
Open-End Wrench 17/19mm .....	1
<b>Q.</b> T-Handle Torx Wrenches T-25 .....	2
<b>R.</b> Flat Head Torx Screws #10-32 x 1/2".....	20
<b>S.</b> Indexable Carbide Inserts 15 x 15 x 2.5mm. 10	



**Figure 9. SB1109 assembly components.**

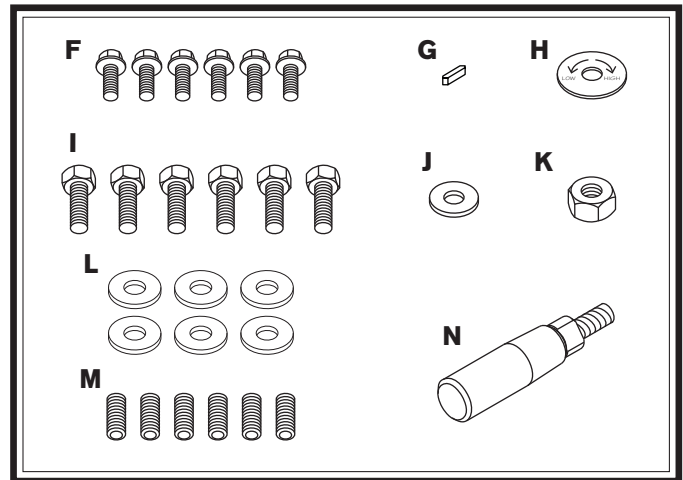

**Figure 10. SB1109 assembly hardware.**

***NOTICE***

**If you cannot find an item on this list, carefully check around/inside the machine and packaging materials. Often, these items get lost in packaging materials while unpacking or they are pre-installed at the factory.**

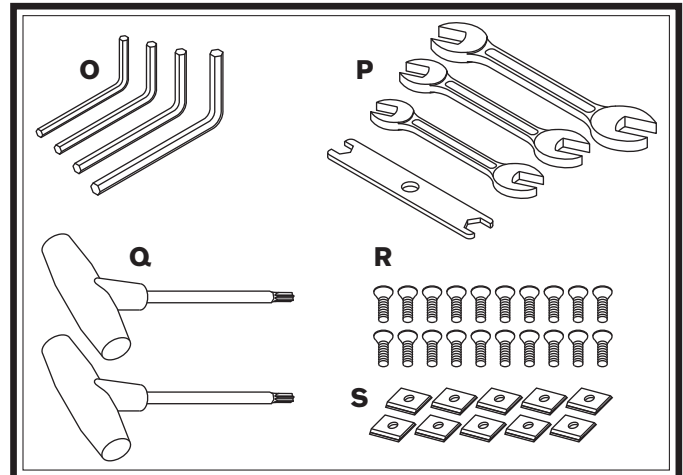

**Figure 11. SB1109 tools and inserts.**



## Cleaning & Protecting

The unpainted surfaces are coated at the factory with a heavy-duty rust preventative that prevents corrosion during shipment and storage. The benefit of this rust preventative is that it works very well. The downside is that it can be time-consuming to thoroughly remove.

Be patient and do a careful job when cleaning and removing the rust preventative. The time you spend doing this will reward you with smooth-sliding parts and a better appreciation for the proper care of the unpainted surfaces.

Although there are many ways to successfully remove the rust preventative, the following process works well in most situations.

### Before cleaning, gather the following:

- Disposable rags
- Cleaner/degreaser (certain citrus-based degreasers work extremely well and they have non-toxic fumes)
- Safety glasses & disposable gloves

**Note:** Automotive degreasers, mineral spirits, or WD•40 can be used to remove rust preventative. Before using these products, though, test them on an inconspicuous area of a painted surface to make sure they will not damage it.



### ⚠ WARNING

Gasoline and petroleum products have low flash points and can explode or cause fire if used for cleaning. Avoid using these products to remove rust preventative.

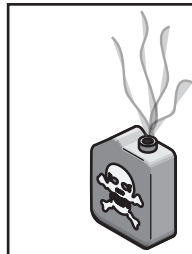

### ⚠ CAUTION

Many cleaning solvents are toxic if inhaled. Minimize your risk by only using these products in a well ventilated area.

## NOTICE

**Avoid chlorine-based solvents, such as acetone or brake parts cleaner that may damage painted surfaces. Always follow the manufacturer's instructions when using any type of cleaning product.**

### Basic steps for removing rust preventative:

1. Put on safety glasses and disposable gloves.
2. Coat all surfaces that have rust preventative with a liberal amount of your cleaner or degreaser and let them soak for a few minutes.
3. Wipe off the surfaces. If your cleaner or degreaser is effective, the rust preventative will wipe off easily.
 

**Note:** To clean off thick coats of rust preventative on flat surfaces, such as beds or tables, use a PLASTIC paint scraper to scrape off the majority of the coating before wiping it off with your rag. (Do not use a metal scraper or it may scratch the surface.)
4. Repeat Steps 2–3 as necessary until clean, then coat all unpainted surfaces with a quality metal protectant or light oil to prevent rust.

### T23692—Orange Power Degreaser

A great product for removing the waxy shipping grease from the *non-painted* parts of the machine during clean up.



Figure 12. T23692 Orange Power Degreaser.

# Location

## Physical Environment

The physical environment where your machine is operated is important for safe operation and longevity of parts. For best results, operate this machine in a dry environment that is free from excessive moisture, hazardous or flammable chemicals, airborne abrasives, or extreme conditions. Extreme conditions for this type of machinery are generally those where the ambient temperature is outside the range of 41°–104°F; the relative humidity is outside the range of 20–95% (non-condensing); or the environment is subject to vibration, shocks, or bumps.

## Electrical Installation

Place this machine near an existing power source. Make sure all power cords are protected from traffic, material handling, moisture, chemicals, or other hazards. Make sure to leave access to a means of disconnecting the power source or engaging a lockout/tagout device.

## Lighting

Lighting around the machine must be adequate enough to perform operations safely. Shadows, glare, or strobe effects that may distract or impede the operator must be eliminated.

## Weight Load

Refer to the **Machine Specifications** for the weight of your machine. Make sure that the surface upon which the machine is placed will bear the weight of the machine, additional equipment that may be installed on the machine, and the heaviest workpiece that will be used. Additionally, consider the weight of the operator and any dynamic loading that may occur when operating the machine.

## Space Allocation

Consider the largest size of workpiece that will be processed through this machine and provide enough space around the machine for adequate operator material handling or the installation of auxiliary equipment. With permanent installations, leave enough space around the machine to open or remove doors/covers as required by the maintenance and service described in this manual.

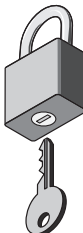
	<p><b>⚠ CAUTION</b></p> <p><b>Children or untrained people may be seriously injured by this machine. Only install in an access restricted location.</b></p>
--	---

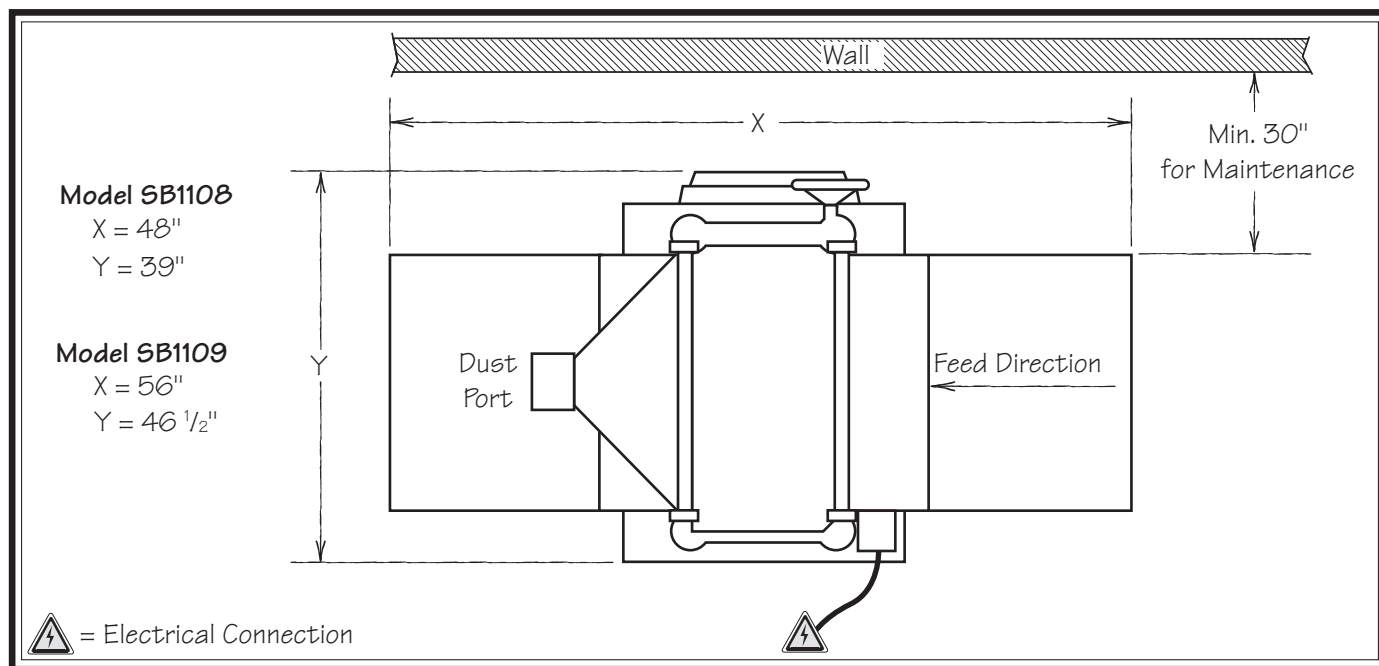

**Figure 13. Minimum working clearances.**

## Lifting & Moving

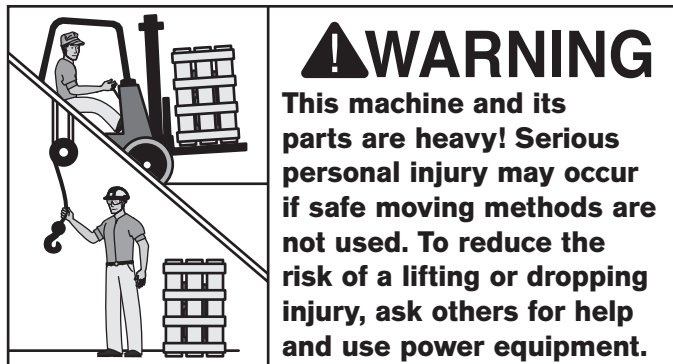

The Models SB1108 and SB1109 require the use of lifting equipment such as a forklift, engine hoist, or boom crane. **DO NOT** attempt to lift or move planer without necessary assistance from other people. Each piece of lifting equipment must be rated for **at least 1000 lbs.** to support dynamic loads that may be applied while lifting.

The cabinet stand of your planer is equipped with four lifting bars that pull out in order to lift and place the planer as shown in **Figure 14** using a forklift or lifting slings.

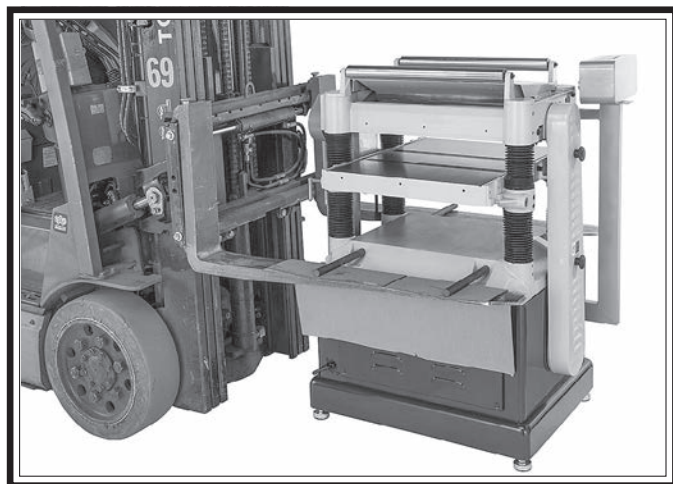

**Figure 14.** Example of lifting planer with forklift.

**Note:** When positioning lift forks, place shop rags or cardboard between the forks and cabinet stand to avoid scratching the paint.

## Assembly

This machine must be fully assembled before it can be operated. Before beginning the assembly process, refer to **Required for Setup** and gather all listed items. To ensure the assembly process goes smoothly, first clean any parts that are covered or coated in heavy-duty rust preventative (if applicable).

Review the **Power Supply** section on **Page 13**, then prepare a permanent location for the planer.

### To assemble planer:

1. Unbolt planer from pallet.
2. Move planer to desired location.
3. Remove (2) hex bolts from bottom of control panel (see **Figure 15**).
4. Rotate control panel 90° (so front is facing forward) and install hex bolts removed in **Step 3** (see **Figure 15**).

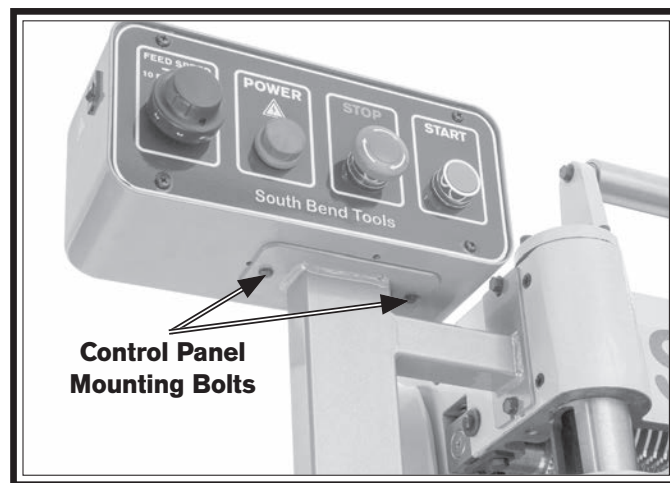

**Figure 15.** Control panel facing forward.

5. Insert 4 x 4 x 10 key into keyway on handwheel shaft (see **Figure 16**).

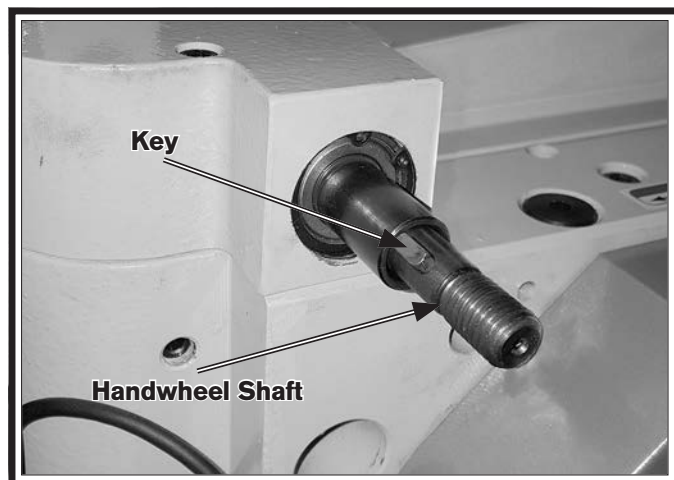

**Figure 16.** Key inserted into handwheel shaft.

6. Line up notch in handwheel bore with key, slide handwheel onto shaft, then slide handwheel direction label onto shaft, and secure with M10-1.75 hex nut and 10mm flat washer (see **Figure 17**).
7. Thread handle into rim of handwheel and tighten with wrench (see **Figure 17**).

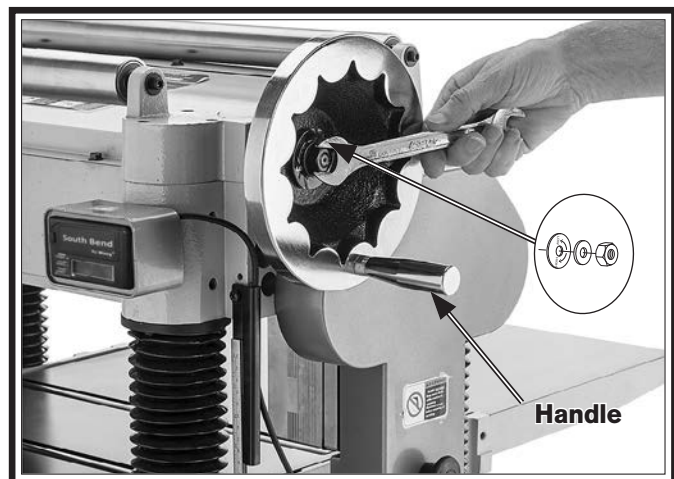

**Figure 17.** Installing handwheel on shaft.

8. Attach each cast-iron extension table to planer table with (3) M8-1.25 x 25 hex bolts and (3) 8mm flat washers as shown in **Figure 18**. Do not fully tighten hex bolts at this time.
9. Thread (3) M8-1.25 x 12 set screws into each extension table at locations shown in **Figure 18**.

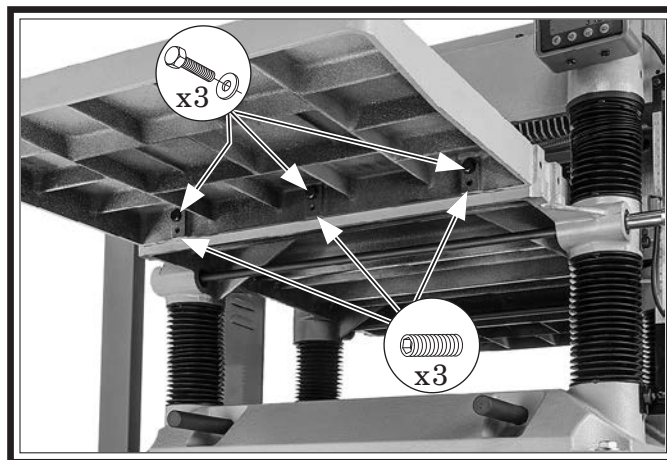

**Figure 18.** Extension table mounting locations.

10. Using a straightedge as a guide, rotate set screws from **Step 9** until extension tables are in plane with main table, then fully tighten hex bolts from **Step 8** (see **Figure 19**).

**Note:** *Bed rollers will give you a false reading if they are raised above table. Move them down or work around them when leveling extension wings (refer to **Bed Roller Height** on **Page 29** for more information).*



**Figure 19.** Leveling extension table.



11. Attach dust hood to planer with (6) M6-1 x 12 flange bolts (see **Figure 20**).

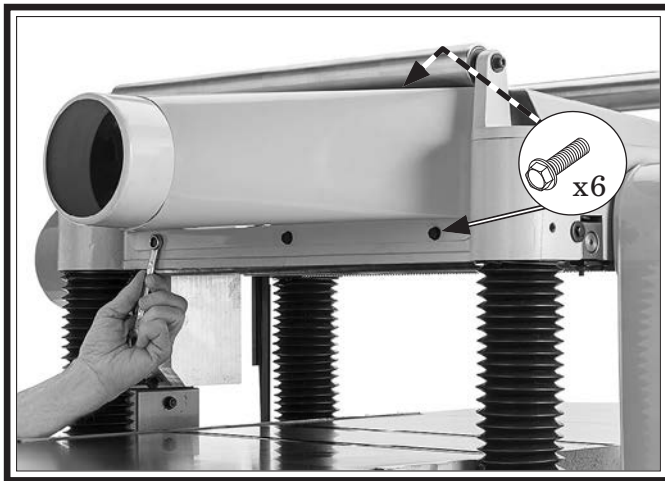

**Figure 20.** Installing dust port (3 of 6 fasteners shown).

12. Remove battery cover from front of digital readout and install (2) AAA batteries (see **Figure 21**), then re-install battery cover.



**Figure 21.** Digital readout batteries installed.

13. Follow instructions in **Calibrating Digital Readout** on Page 31.

## Dust Collection

### ⚠ CAUTION

This machine creates a lot of wood chips/dust during operation. Breathing airborne dust on a regular basis can result in permanent respiratory illness. Reduce your risk by wearing a respirator and capturing the dust with a dust-collection system.

#### Minimum CFM at Dust Port:

- **SB1108: 400 CFM**
- **SB1109: 600 CFM**

*Do not confuse this CFM recommendation with the rating of the dust collector. To determine the CFM at the dust port, you must consider these variables: (1) CFM rating of the dust collector, (2) hose type and length between the dust collector and the machine, (3) number of branches or wyes, and (4) amount of other open lines throughout the system. Explaining how to calculate these variables is beyond the scope of this manual. Consult an expert or purchase a good dust collection "how-to" book.*

#### To connect machine to a dust collector:

1. For SB1108, fit a 4" dust hose (SB1109 requires 5" dust hose) that is connected to a dust collector over dust port (see **Figure 22**), and secure in place with a hose clamp.

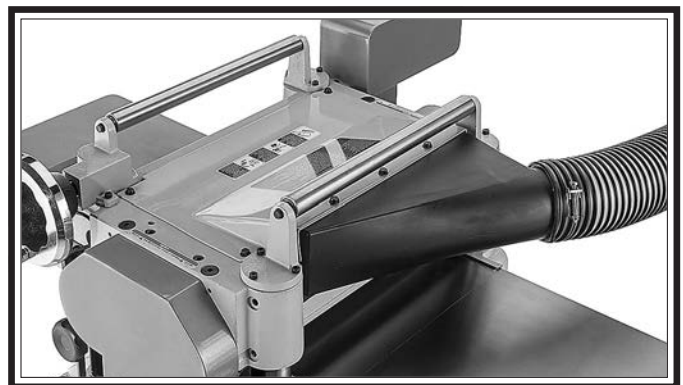

**Figure 22.** Example of dust hose connected to dust port.

2. Tug hose to make sure it does not come off.

**Note:** A tight fit is necessary and ensures proper performance during operation.

# Checking Gearbox Oil Level

Before starting your machine for the first time, check the gearbox oil level. The proper oil level is just even with the bottom of the fill plug hole. See **Gearbox Oil** on **Page 37** for more information. DO NOT mix oil types.

Tools Needed	Qty
Open-End Wrench 17mm .....	1
Hex Wrench 6mm .....	1

### To check gearbox oil level:

1. Remove gearbox oil fill plug (see **Figure 23**).

**Note:** For easier access to the fill plug, remove gearbox cover (see **Figure 23**).

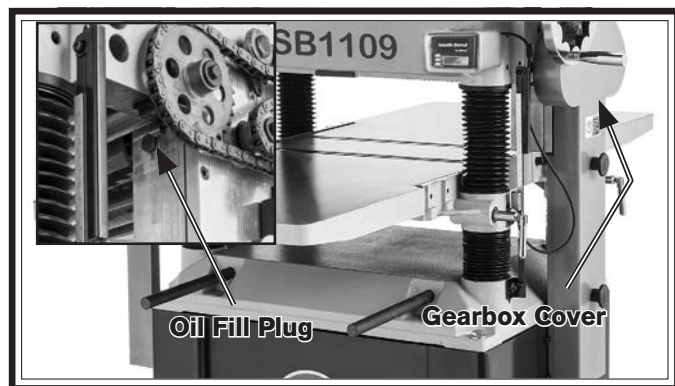

**Figure 23.** Location of gearbox oil fill plug.

2. Wipe clean 6mm hex wrench and insert short end inside oil fill hole with inserted end pointing down, then remove it.
  - If end of hex wrench is coated with oil, then gearbox oil level is okay. Replace fill plug and continue setup.
  - If end of hex wrench is not coated with oil, then you need to add more oil. Refer to **Gearbox Oil** on **Page 37** for instructions on how to do this.

**Note:** We recommend that you replace the gearbox oil after the first 20 hours of operation. This is a normal break-in procedure and will help maximize the service life of the machine by flushing away any particles from the break-in and manufacturing process.

# Test Run

After all preparation steps have been completed, the machine and its safety features must be tested to ensure correct operation. If you discover a problem with the operation of the machine or its safety components, do not operate it further until you have resolved the problem.

**Note:** Refer to **Troubleshooting** on **Page 47** for solutions to common problems that occur with all planers. If you need additional help, contact our Tech Support or (360) 734-1540.

The test run consists of verifying the following:

- Motors power up and run correctly.
- EMERGENCY STOP button works correctly.

**⚠ WARNING**

**Serious injury or death can result from using this machine BEFORE understanding its controls and related safety information. DO NOT operate, or allow others to operate, machine until the information is understood.**

**⚠ WARNING**

**DO NOT start machine until all preceding setup instructions have been performed. Operating an improperly set up machine may result in malfunction or unexpected results that can lead to serious injury, death, or machine/property damage.**

### To test run machine:

1. Clear all tools and objects used during assembly and preparation away from machine.
2. Push EMERGENCY STOP button in.
3. Connect machine to power supply.



4. Twist EMERGENCY STOP button clockwise until it pops out (see **Figure 24**). This resets switch and machine can now start.

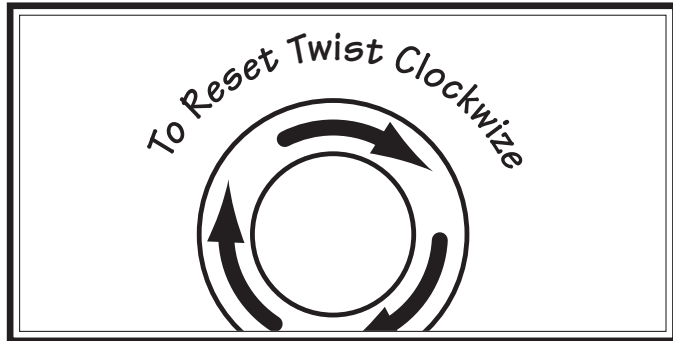

**Figure 24. Resetting EMERGENCY STOP button.**

5. Press START button to turn machine **ON**, then turn Feed Speed dial from minimum to maximum. Verify motors start up and run smoothly without any unusual vibrations or noises.
  - When operating correctly, machine runs smoothly with little or no vibration or rubbing noises.
  - Investigate and correct strange or unusual noises or vibrations before operating machine further. **ALWAYS** disconnect machine from power when investigating or correcting potential problems.
6. Press EMERGENCY STOP button to turn machine **OFF**.
7. **WITHOUT** resetting EMERGENCY STOP button, try to start machine by pressing START button. The machine should not start.
  - If machine *does not* start, the EMERGENCY STOP button safety feature is working correctly. Test Run is complete.
  - If machine *does* start (with EMERGENCY STOP button pushed in), immediately disconnect power to machine. EMERGENCY STOP button safety feature is not working correctly and must be replaced before further using the machine. Call Tech Support for help.

## Inspections & Adjustments

The following list of adjustments were performed at the factory before your machine was shipped:

- **Chip Breaker Height**.....Page 39
- **Pressure Bar Height** .....Page 39
- **Infeed/Outfeed Roller Height** .....Page 39
- **Roller Spring Tension** .....Page 42
- **Chip Deflector Positioning**.....Page 42
- **Table Height Chain Tension** .....Page 44
- **Table Parallelism**.....Page 45

Be aware that machine components can shift during the shipping process. Pay careful attention to these adjustments as you test run your machine. If you find that the adjustments are not set according to the procedures in this manual or your personal preferences, re-adjust them.

### **NOTICE**

**After approximately 16 hours of operation, V-belts will stretch and seat into pulley grooves and need to be properly tensioned to ensure good power transfer from motor and avoid severely reducing life of V-belts. Refer to Tensioning/Replacing V-Belts on Page 38 for detailed instructions.**

## Operation Overview

The purpose of this overview is to provide the novice machine operator with a basic understanding of how the machine is used during operation, so they can more easily understand the controls discussed later in this manual.

**Note:** *Due to the generic nature of this overview, it is not intended to be an instructional guide for performing actual machine operations. To learn more about specific operations and machining techniques, seek training from people experienced with this type of machine, and do additional research outside of this manual by reading "how-to" books, trade magazines, or websites.*

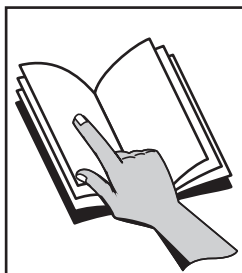

### **! WARNING**

To reduce the risk of serious injury when using this machine, read and understand this entire manual before beginning any operations.

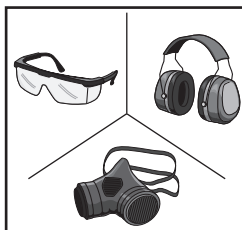

### **! WARNING**

To reduce risk of short and long term injury, wear eye, ear, and lung protection when using this machine.

### **NOTICE**

If you are not experienced with this type of machine, **WE STRONGLY RECOMMEND** that you seek additional training outside of this manual. Read books/magazines or get formal training before beginning any projects. Regardless of the content in this section, **South Bend Tools will not be held liable for accidents caused by lack of training.**

To complete a typical operation, the operator does the following:

1. Examines workpiece to make sure it is suitable for planing.
2. Puts on safety glasses or face shield, a respirator, and hearing protection.
3. Places workpiece on table with flat side down and correctly adjusts table height for workpiece thickness and depth of cut.
  - If workpiece is bowed, operator surface planes workpiece on a jointer, with cupped side facing down, until one side is flat. Doing so ensures that it sits solidly on planer table during operation.
4. When all safety precautions have been taken, turns planer **ON**.
5. Stands to one side of planer path to reduce risk of kickback injuries, then feeds workpiece into planer until infeed roller grabs it.
  - Note:** *Infeed and outfeed rollers control feed rate of workpiece as it passes through planer. Operator does not push or pull on workpiece.*
  - If cut is too deep and bogs down planer, operator immediately reduces depth of cut.
6. Once workpiece is clear of outfeed roller and stops moving, operator removes workpiece from outfeed table and measures workpiece thickness. If further planing is required, operator raises table slightly, such as ½-turn of table height handwheel (approximately ¼ to ½ turn of the handwheel), then feeds workpiece into front of planer again.
7. Operator continues process until desired workpiece thickness is achieved, then turns machine **OFF**.

## Stock Inspection & Requirements

Some workpieces are not safe to use or may require modification before they are. **Before planing, inspect all workpieces for the following:**

- **Material Type:** This machine is only intended for workpieces of natural wood fiber. Attempting to use workpieces of any other material that may break apart during operation could lead to serious personal injury and property damage.
- **Foreign Objects:** Inspect lumber for defects and foreign objects (nails, staples, embedded gravel, etc.). If you have any question about the quality of your lumber, DO NOT use it. Remember, wood stacked on a concrete floor can have small pieces of stone or concrete pressed into the surface.
- **Large/Loose Knots:** Loose knots can become dislodged during operation. Large knots can cause kickback and machine damage. Always use workpieces that do not have large/loose knots.
- **Wet or "Green" Stock:** Avoid using wood with a high water content. Wood with more than 20% moisture content or wood exposed to excessive moisture (such as rain or snow), will cut poorly and cause excessive wear to the machine. Excess moisture can also hasten rust and corrosion of the machine and/or individual components.
- **Excessive Warping:** Workpieces with excessive cupping, bowing, or twisting are dangerous to cut because they are unstable and often unpredictable when being cut. DO NOT use workpieces with these characteristics!
- **Minor Cupping:** Though it is always best to flatten the cupped side on a jointer before planing, workpieces with slight cupping can be safely supported if the cupped side is facing the table. On the contrary, a workpiece supported on the bowed side will rock during operation and could cause severe injury from kickback.

## Wood Types

The species of wood, as well as its condition, greatly affects the depth of cut the planer can effectively take with each pass.

The chart below shows the Janka Hardness Rating for a number of commonly used species. The larger the number, the harder the workpiece, and the less material should be removed in any one pass for good results.

**Note:** *The Janka Hardness Rating is expressed in pounds of force required to embed a 0.444" steel ball into the surface of the wood to a depth equal to half the ball's diameter.*

Species	Janka Hardness
Ebony	3220
Red Mahogany	2697
Rosewood	1780
Red Pine	1630
Sugar Maple	1450
White Oak	1360
White Ash	1320
American Beech	1300
Red Oak	1290
Black Walnut	1010
Teak	1000
Black Cherry	950
Cedar	900
Sycamore	770
Douglas Fir	660
Chestnut	540
Hemlock	500
White Pine	420
Basswood	410
Eastern White Pine	380
Balsa	100

## Planing Tips

- Inspect your lumber for twisting or cupping, and surface cupped side on a jointer if necessary before planing workpiece.
- Scrape off all glue when planing glued-up panels. Dried glue can quickly dull inserts.
- DO NOT plane more than one piece at a time side by side.
- Never remove more than the recommended amount of material on each pass. Only remove a small amount of material on each pass when planing wide or dense stock.
- Support the workpiece on both ends. Get assistance from another person if you are planing long lumber, or use roller stands to support the workpiece.
- Measure the workpiece thickness with calipers to get exact results.
- Use a jointer on one side of the workpiece and the planer for the other.
- Use the entire width of the planer to wear knives/inserts evenly. With narrow workpieces, alternate between far left, far right, and the middle of the table. Your knives/inserts will remain sharp much longer.
- To avoid "chip marks", always plane WITH the grain direction of the wood. Never plane cross-grain or end-grain.
- Plane ONLY natural wood fiber. Do not plane wood composites or other materials that could break up in the planer and cause operator injury or damage to planer.
- Always true cupped or warped stock on a jointer before planing.

## Common Cutting Problems

Below is a list of wood characteristics you may encounter when planing. The following descriptions of defects will give you some possible answers to problems you may encounter while planing different materials. Possible solutions follow the descriptions.

### Chipped Grain

**Problem:** Usually a result of cutting against the grain, planing lumber with knots or excessive amount of cross grain, or using dull knives/inserts.

**Note:** *Some amount of chipping is normal with highly figured wood.*

**Solution:** Decrease the depth of cut. Reduce the feed rate. Inspect your lumber and determine if its grain pattern is causing the problem. If the lumber does not show substantial crossgrain, inspect your knives/inserts.

### Fuzzy Grain

**Problem:** Usually caused by surfacing lumber with too high of a moisture content. Sometimes fuzzy grain is an unavoidable characteristic of some woods, such as basswood. Fuzzy grain can also be caused by dull knives/inserts.

**Solution:** Check the lumber with a moisture meter. If moisture is greater than 20%, sticker the lumber and allow it to dry. Otherwise, inspect the knife/insert condition.

## Pitch & Glue Build-up

**Problem:** Glue and resin buildup on the rollers and cutterhead will cause overheating by decreasing cutting sharpness while increasing drag in the feed mechanism. The result can include scorched lumber, uneven knife/insert marks, and chatter.

**Solution:** Clean the rollers and cutterhead.

## Chip Marks or Indentations

**Problem:** Chip indentation or chip bruising is the result of wood chips not being thrown away from the cutterhead and out of the machine. Instead they are carried around the cutterhead, deposited on the planed surface and crushed by the outfeed roller. Some of the causes of chip indentation are:

- Wood chips/sawdust not being properly expelled from the cutterhead.
- The type of lumber being planed. Certain species have a tendency to chip bruise.
- Dull knives/inserts.
- Excessive depth of cut.

**Solution:**

- Use a proper dust-collection system; adjust chip deflector in or out as necessary.
- Lumber must be completely dry, preferably kiln-dried (KD). Air-dried (AD) lumber must be seasoned properly and have no surface moisture. DO NOT surface partially-air-dried (PAD) lumber.
- Make sure planer knives/inserts are sharp.
- Reduce depth of cut.

## Snipe

**Problem:** Occurs when board ends have more material removed than the rest of the board. Usually caused when the workpiece is not properly supported as it goes through the machine. In many cases, however, a small amount of snipe is inevitable and cannot be completely prevented.

**Solution:** Hold workpiece up slightly as it leaves the outfeed end of the planer. The best way to deal with snipe is by planing lumber longer than your intended work length and then cutting off the excess after planing is completed.

## Rippled Cut

**Problem:** Regularly spaced indentations across face of workpiece are caused by excessive outfeed roller pressure or excessive feed rate.

**Solution:** Reduce outfeed roller pressure; reduce feed rate.



# Depth of Cut

## Table Movement

One Full Revolution of Handwheel..... 1/16"

## Material Thickness Range

SB1108 ..... 3/16" – 6"  
 SB1109..... 1/4" – 8"

The depth of cut on a planer means the amount of material that is removed from the top of the workpiece as it passes underneath the cutterhead.

The depth of cut is set by adjusting the distance of the table below the cutterhead. This distance is the thickness of the workpiece minus the depth of cut. The planing depth of cut is controlled by using the table height handwheel on the right side of the machine. Rotating the handwheel clockwise raises the table.

Although the correct depth of cut varies according to wood hardness and workpiece width, we recommend the maximum depth of cut (per pass) be no more than 1/16". A series of light cuts will give better end results and put less stress on the planer than trying to take off too much material in a single pass.

The depth of cut can be referenced directly from the scale on the front of the planer, as shown in the figure below.

**Note:** *The scale and digital readout function as a general guide only, and is not intended for low-tolerance, precision results. To ensure accuracy, use a tape measure or caliper to measure your workpiece thickness after each pass.*

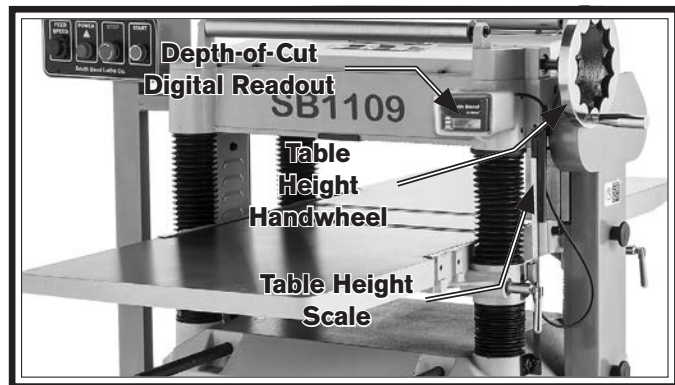

**Figure 25. Location of table controls.**

# Setting Feed Rate

Feed Rate..... 10–28 FPM

The infeed and outfeed rollers move the workpiece through the planer while keeping it flat and providing a consistent rate of movement. The speed that these rollers move the workpiece through the planer is the feed rate.

Generally, low feed rates are used for finishing passes, while higher feed rates are used for dimensioning passes.

Use the FEED SPEED control knob (see **Figure 26**) to adjust the feed rate according to workpiece type and desired results.

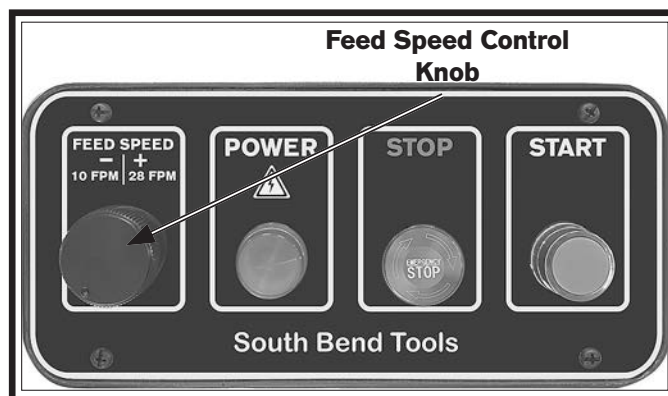

**Figure 26. Feed speed control knob.**



## Bed Roller Height

The correct height of the bed rollers will vary, depending on the type of material you intend to plane. However, as a general rule, keep the bed roller height range within the listed range above the table surface, as illustrated.

Bed Roller Height Range ..... 0.002"–0.020"

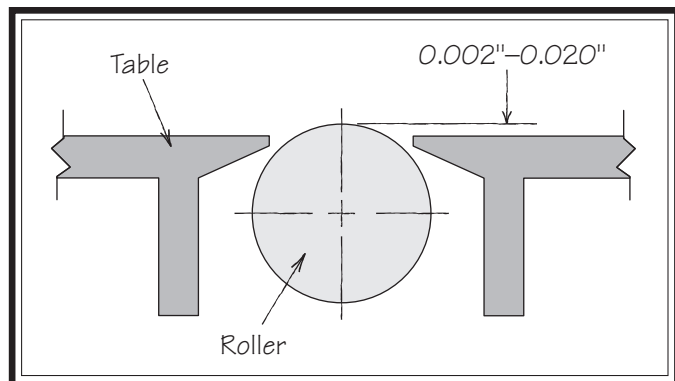

**Figure 27. Recommended bed roller height above the table surface.**

When planing rough stock, set the rollers high to keep the lumber from dragging along the bed. When planing milled lumber, set the rollers low to help minimize snipe.

To ensure accurate results and make the adjustment process quicker and easier, we recommend using a Rotacator (refer to **Accessories**) to gauge the bed roller height from the table surface. If a Rotacator is not available, a straightedge and feeler gauges can be used, but care must be taken to achieve accurate results.

### NOTICE

**Bed rollers that are not adjusted to the correct height or out of alignment with each other can cause poor finishes, inconsistent planing thickness, and other undesirable results.**

Items Needed	Qty
Hex Wrench 3mm .....	1
Open-End Wrench 14mm .....	1
Rotacator (optional, see <b>Page 32</b> ).....	1

### To adjust bed roller height:

1. DISCONNECT MACHINE FROM POWER!
2. Completely lower table to give yourself enough room to work.
3. Loosen set screw above each of four roller adjustment cams—there are two on each side of planer table (see **Figure 28**).

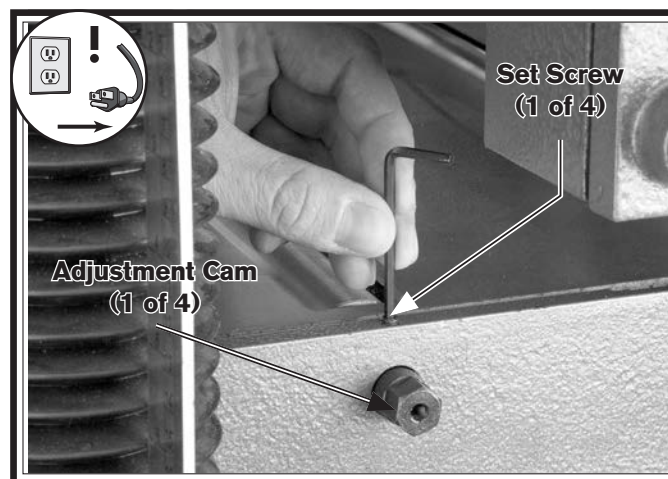

**Figure 28. Location of bed roller height controls (two on each side of planer table).**

4. Rotate eccentric adjustment cams on each side of roller to raise or lower bed rollers to desired height above table surface.
5. Verify both sides of each roller are at the same height, then re-tighten set screws to secure in place.

**IMPORTANT:** *Bed rollers MUST be parallel with the table.*

6. Re-check roller heights to make sure they did not change while being secured.

— If roller heights *are not* correct, repeat this procedure until they are.

# Rotating/Replacing Cutterhead Inserts

The spiral cutterhead is equipped with 4-sided indexable carbide inserts. Each insert can be removed, rotated, and re-installed to use any one of its four cutting edges. Therefore, if one cutting edge becomes dull or damaged, simply rotate it 90° (as shown below) to use a sharp cutting edge.

The inserts have a reference dot on one corner. The position of the reference dot on installed inserts can be used to track which edges are sharp/unused and which edges are dull or damaged. Replace inserts once the reference dot has been rotated back to its original position.

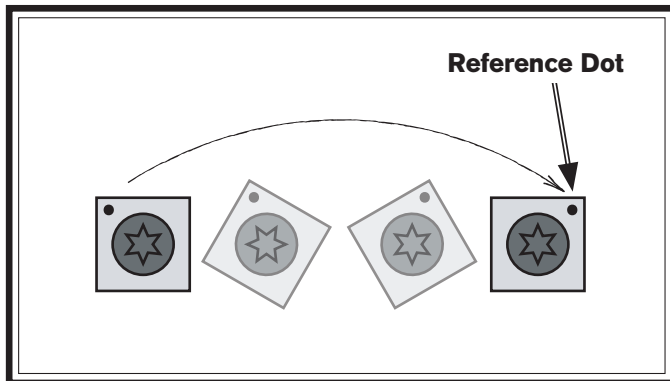

**Figure 29. Insert rotating sequence.**

Items Needed	Qty
Hex Wrench 5mm .....	1
Wrench or Socket 10mm.....	1
T-25 Torx Bit .....	1
Carbide Cutterhead Inserts.....	As Needed
Rags .....	As Needed
Light Machine Oil .....	As Needed

**⚠ CAUTION**

**The carbide inserts are very sharp and can quickly cut your hands. ALWAYS use caution when handling these parts to reduce the risk of personal injury.**

**To rotate or replace a helical cutterhead insert:**

1. DISCONNECT MACHINE FROM POWER!
2. Remove dust hood, top cover, and belt cover.

3. Remove any sawdust or debris from head of insert, Torx screw, and surrounding area (see **Figure 30**).

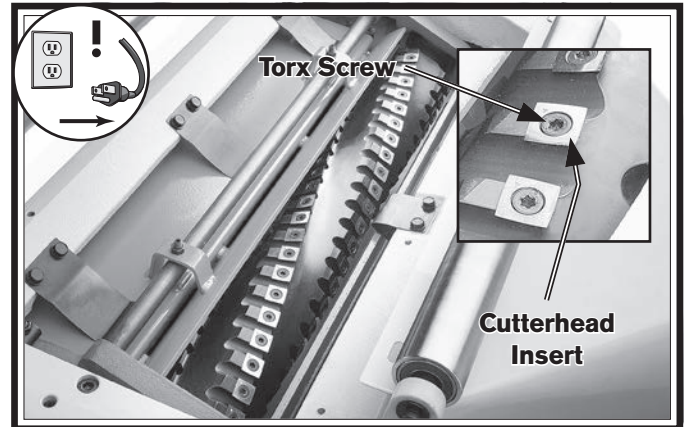

**Figure 30. Example of cutterhead inserts and Torx screws.**

4. Remove Torx screw and insert, then clean all dust and debris from both parts and cutterhead pocket.

**Note:** *Proper cleaning of insert, Torx screw, and cutterhead pocket is critical to achieving a smooth finish. Dirt or dust trapped between insert and cutterhead will raise insert, and make marks on your workpiece when planing.*

**Tip:** *Use low-pressure compressed air or a vacuum nozzle to clean out cutterhead pocket.*

5. Replace insert so that a fresh cutting edge faces outward.

— If all four insert cutting edges have been used, replace insert with a new one. Always position insert reference dot in same position when installing a new insert to aid in rotational sequencing.

6. Lubricate Torx screw threads with a very small amount of light machine oil, wipe excess off, and torque screw to 50–55 inch/pounds.

**Note:** *If too much oil is applied to the threads, excess oil will attempt to squeeze out of the threaded hole and raise insert during installation, bringing it out of height alignment.*

## Digital Readout

The digital readout has two modes of use, Absolute (ABS) and Incremental (INC).

When used in ABS mode, the readout displays the distance between the table and the edge of the cutterhead insert at bottom-dead-center (BDC) to show workpiece thickness.

When INC mode is used, the readout displays the distance between the current position of the table and the position of the table where incremental mode was set at 0 to show how much material was removed from the workpiece.

To enter INC mode, press ABS/INC until INC is displayed. Each time the unit is placed in INC mode, the incremental value is reset to 0.

The digital readout is powered by 2 AAA batteries. The readout will display a battery icon when the battery level is low and needs replacing. Each time the batteries are replaced, the digital readout will need to be calibrated.

### To calibrate digital readout:

1. Raise table all the way up.
2. Press mm/in button until 'in' is displayed.
3. Press ABS/INC button until ABS is displayed. (This should already be displayed by default after the batteries are replaced.)
4. Press and hold ON/OFF (CAL) button until ABS begins to flash (2–3 seconds).
5. Press + (mm/in) or – (ABS/INC) buttons to adjust readout until it displays  $\frac{1}{4}$ ".
6. Press ON/OFF button to return to normal operating mode.

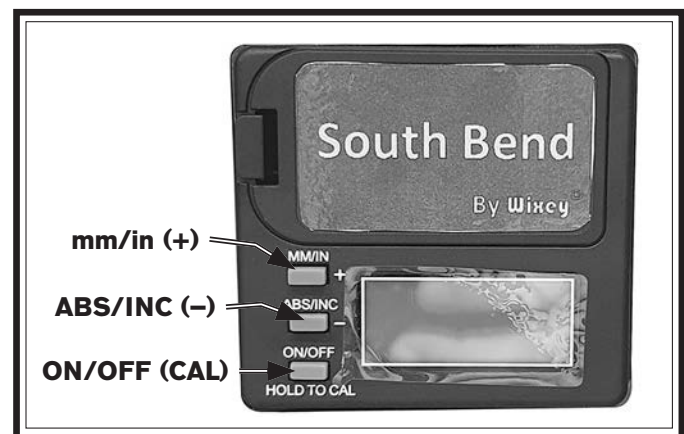

Figure 31. Digital readout.

## Accessories

This section includes the most common accessories available for your machine through our exclusive dealer, Grizzly Industrial, Inc., at [grizzly.com](http://grizzly.com).

### **! WARNING**

Installing unapproved accessories may cause machine to malfunction, resulting in serious personal injury or machine damage. To reduce this risk, only install accessories recommended by South Bend or Grizzly.

### **NOTICE**

Refer to Grizzly's website or latest catalog for additional recommended accessories.

#### **W1218A—Rotacator Precision Planer Tool**

The Rotacator is a dial indicator on a magnetic base, designed for quickly and accurately setting the critical tolerances needed when making planer adjustments. Perfect for adjusting infeed/outfeed rollers, pressure bars, chip breakers, and bed rollers. Also a great setup tool for other machines! Accurate to 0.001". Indicator rotates 360°.

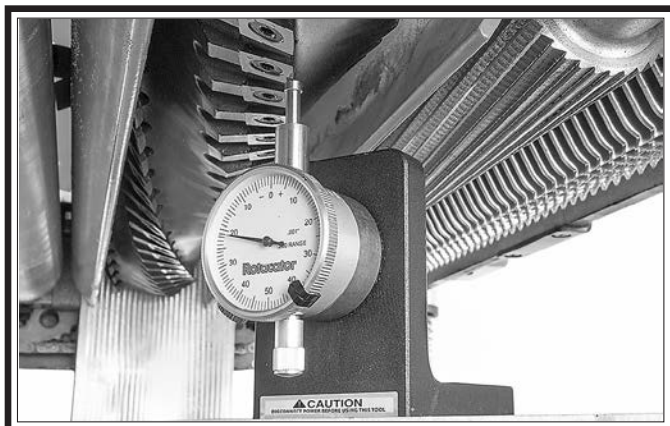

Figure 32. W1218A Rotacator™ Precision Planer Tool.

#### **T28000—Bear Crawl (for SB1108)**

#### **T28923—Bear Crawl "Papa Bear" (for SB1109) Heavy Duty Mobile Base**

The Grizzly Bear Crawl Mobile Base, with a 1200 lb. capacity, steel and polyurethane heavy-duty ball bearing wheels, and toe flip-stops, will make this mobile base a staple under your machines for years to come.

Adjusts from:

T28000—19" x 21" to 29½" x 29½"

T28923—19" x 26" to 29½" x 34½"

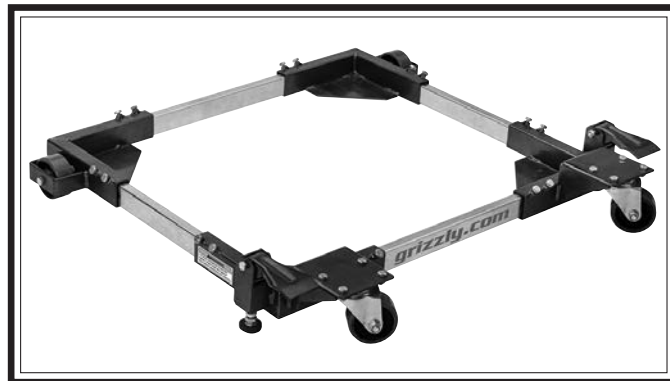

Figure 33. T28000 Bear Crawl Heavy-Duty Mobile Base.

#### **H9893—Indexable Carbide Inserts, 10-Pack**

These indexable carbide inserts are designed for use in spiral or helical cutterhead systems and made to last up to 10 times longer than a set of HSS steel straight blades. Made of solid carbide. Size: 15 x 15 x 2.5mm.

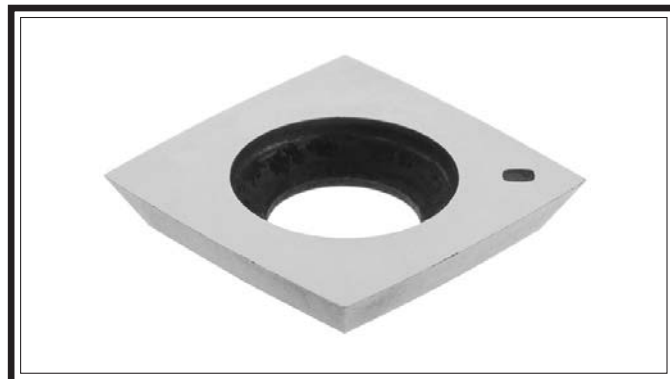

Figure 34. H9893 Indexable Carbide Inserts.

**order online at [www.grizzly.com](http://www.grizzly.com) or call 1-800-523-4777**



**G5562—SLIPIT® 1 Qt. Gel**  
**G5563—SLIPIT® 12 Oz. Spray**  
**G2871—Boeshield® T-9 12 Oz. Spray**  
**G2870—Boeshield® T-9 4 Oz. Spray**  
**H3788—G96® Gun Treatment 12 Oz. Spray**  
**H3789—G96® Gun Treatment 4.5 Oz. Spray**



**Figure 35. Recommended products for protecting unpainted cast iron/steel parts on machinery.**

#### **SB1365—South Bend Way Oil-ISO 68**

Engineered for the high pressure exerted on horizontal or vertical ways and slides. Protects against rust and corrosion. Ensures stick-free, smooth motion which maximizes finishes and extends the life of your machine. Won't gum up! 12 oz. AMGA#2 (ISO 68 Equivalent).



**Figure 36. SB1365 Way Oil.**

#### **T28042—Moly-D Industrial Gear Oil-ISO 320**

This industrial gear oil from Primrose has been developed specifically for the high temperatures and pressures typical of modern industrial applications. 1-gallon size.

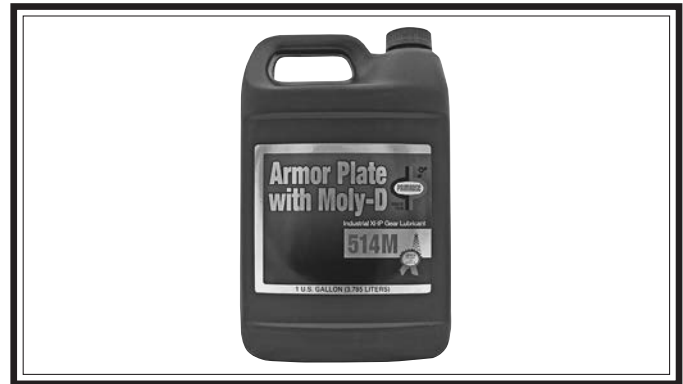

**Figure 37. T28042 Gear Oil.**

#### **T26419—Syn-O-Gen NLGI #2 Synthetic Grease**

100% pure synthesized hydrocarbon basestocks compounded with special thickeners and additives make Syn-O-Gen non-melt, tacky, and water resistant. Extremely low pour point, high temperature oxidation, and thermal stability produce a grease unmatched in performance.

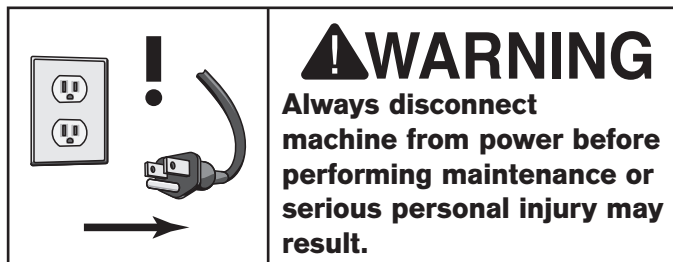

**Figure 38. T26419 Synthetic Grease.**

**order online at [www.grizzly.com](http://www.grizzly.com) or call 1-800-523-4777**



# Maintenance Schedule Cleaning & Protecting



For optimum performance from your machine, follow this maintenance schedule and refer to any specific instructions given in this section.

**Note:** *This maintenance schedule is based on average daily usage. Adjust the maintenance schedule to match your usage, to keep your planer running smoothly, and to protect your investment.*

### Ongoing:

- Clean machine and protect unpainted cast iron.
- Lubricate feed rollers bushings (**Page 35**).
- Tighten loose mounting bolts.
- Check/rotate/replace damaged or worn inserts (**Page 30**).
- Check/repair/replace worn or damaged wires.
- Resolve any other unsafe condition.

### Every 40 Hours of Operation:

- Clean cutterhead and inspect inserts (**Page 30**).
- Lubricate table columns and leadscrews (**Page 35**).
- Inspect/Clean anti-kickback fingers (**Page 37**).

### Every 160 Hours of Operation:

- Check/tension/replace V-belts (**Page 38**).
- Clean/vacuum dust buildup from inside cabinet and off motor.
- Lubricate table height worm gear (**Page 36**).
- Lubricate table height chain and sprockets (**Page 36**).
- Lubricate drive chain and sprockets (**Page 36**).

### Yearly:

- Change gearbox oil (**Page 37**).

Vacuum excess wood chips and sawdust, and wipe off the remaining dust with a dry cloth. If any resin has built up, use a resin-dissolving cleaner to remove it.

Protect the unpainted cast-iron table by wiping it clean after every use—this ensures moisture from wood dust does not remain on bare metal surfaces. Keep the table rust-free with regular applications of products like G96® Gun Treatment, SLIPIT®, or Boeshield® T-9 (see **Page 33** for more details).

## Machine Storage

All machinery will develop serious rust problems and corrosion damage if it is not properly prepared for storage. If decommissioning this machine, use the steps in this section to ensure that it remains in good condition.

### To prepare machine for storage or decommission from service:

1. Disconnect all power sources to the machine.
2. Thoroughly clean all unpainted, bare metal surfaces, then coat them with a light weight grease or rust preventative. Take care to ensure these surfaces are completely covered but that the grease or rust preventative is kept off of painted surfaces.

**Note:** *If the machine will be out of service for only a short period of time, use way oil or a good grade of medium-weight machine oil (not auto engine oil) in place of the grease or rust preventative.*

3. Loosen or remove belts so they do not become stretched while the machine is not in use.

4. Fill the gearbox with the recommended gear oil so components above the normal oil level do not develop rust. (Make sure to put a tag on the controls as a reminder for the re-commissioning process to adjust the gear oil level before starting the machine.)

**Note:** *If the machine will be out of service for only a short period of time, start the machine once a week and run all gear-driven components for a few minutes. This will put a fresh coat of gear oil on the gearing components inside the gearbox.*

5. Completely cover the machine with a tarp or plastic sheet that will keep out dust and resist liquid or moisture. If machine will be stored in/near direct sunlight, use a cover that will block the sun's rays.

## Lubrication

### NOTICE

**Failure to follow reasonable lubrication practices as instructed in this manual for your machine could lead to premature failure of components and void the warranty.**

Your planer features bearings that are lubricated and sealed at the factory. These bearings do not require any further attention unless they need to be replaced. If a bearing fails, your planer will probably develop a noticeable rumble or vibration, which will increase when the machine is under a load. The bearings are standard sizes and can be replaced through Grizzly.

Follow the maintenance schedule on this page and the procedures beginning on **Page 33** to properly lubricate the other planer components, which are essential for long life and trouble-free operation of your planer.

## Feed Roller Bushings

Oil Type .....SB1365 or ISO 68 Equivalent  
Oil Amount ..... 2–3 Drops  
Frequency ..... Every 8 Hours of Operation

The infeed and outfeed rollers rotate inside bushing blocks on both ends of the rollers. Add 2–3 drops of ISO 68 machine oil to the center hole of the four feed roller tension adjustment bolts on top of the head casting, as shown in **Figure 39**.

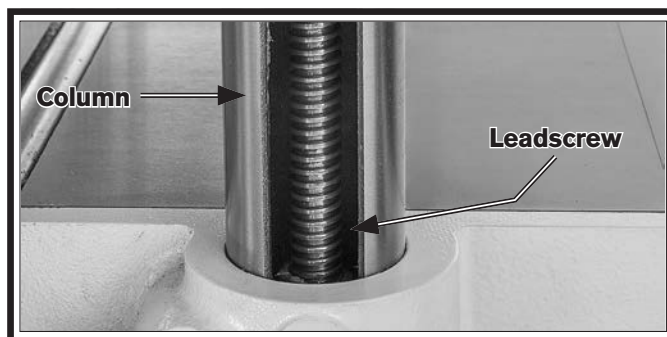

**Figure 39. Lubrication locations for feed roller bushings.**

## Columns & Leadscrews

Oil Type .....SB1365 or ISO 68 Equivalent  
Oil Amount ..... Thin Coat  
Grease Type ..... NLGI#2 Equivalent  
Frequency ..... Every 40 Hours of Operation

The table rides on the columns and is moved by the rotation of the leadscrews inside the columns. Loosen the dust sleeve to access the columns and leadscrews (see **Figure 40**). Apply a thin coat of ISO 68 machine oil to the outside surface of the columns and brush on a light application of multi-purpose grease to the leadscrew threads. Move the table up and down to distribute the lubricant.

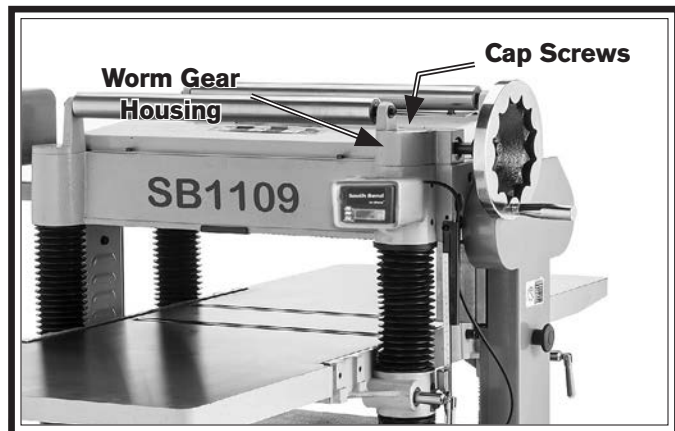

**Figure 40. Dust sleeve removed to expose column and leadscrew for lubrication.**

### Table Height Worm Gear

Grease Type..... T26419 or NLGI#2 Equivalent  
 Frequency ..... Every 160 Hours of Operation

Remove the three cap screws that secure the worm gear housing (see **Figure 41**), then lift the housing and handwheel assembly off the machine. Clean away any debris from the housing and gears, then brush on a moderate amount of multi-purpose grease to the gear teeth.

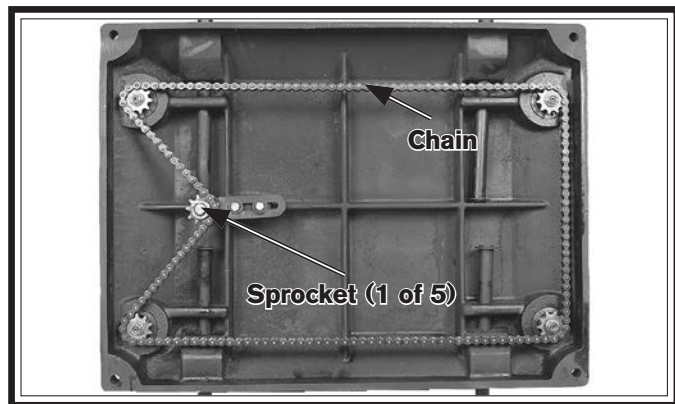

**Figure 41.** Location of table height worm gear housing.

### Table Height Chain & Sprockets

Grease Type..... T26419 or NLGI#2 Equivalent  
 Frequency ..... Every 160 Hours of Operation

The table leadscrews are synchronized by the table height chain and sprockets located underneath the planer base (see **Figure 42**). Use shop rags and mineral spirits to clean away debris and grime, then brush a light coat of multi-purpose grease onto the chain and sprockets.

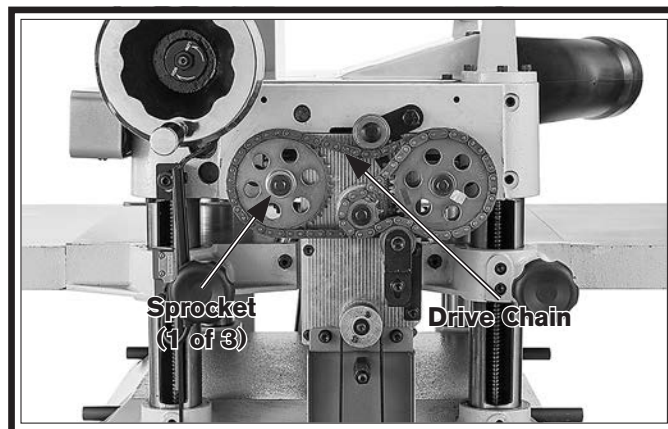

**Figure 42.** Table height chain and sprockets as viewed from underneath the base.

### Drive Chain & Sprockets

Grease Type..... T26419 or NLGI#2 Equivalent  
 Frequency ..... Every 160 Hours of Operation

The infeed and outfeed rollers receive the transferred power from the cutterhead through the drive chain system on the right side of the machine, as shown in **Figure 43**.



**Figure 43.** Gearbox cover removed to expose drive chains and sprockets for lubrication.

Use shop rags and mineral spirits to clean away any debris and grime, then brush a light coat of multi-purpose grease onto the chain and sprockets.



## Gearbox Oil

Oil Type ..... T28042 or ISO 320 Equivalent  
 Oil Amount ..... 20 Oz.  
 Frequency ..... After First 20 Hours, Then Yearly

**Note:** SAE 140 Gear Oil or SAE 85W-140 multi-weight gear oil may also be used. **DO NOT mix oil types!**

**Note:** We recommend that you replace the gearbox oil after the first 20 hours of operation. This is a normal break-in procedure and will help maximize the service life of the machine by flushing away any particles from the break-in process.

Although it is not necessary to remove the drive chain cover to access the fill and drain plugs, it is more convenient to do so (see **Figures 44–45**). Drain the old oil into a pan. Re-install the drain plug, then refill the gearbox with ISO 320 or equivalent oil until it just reaches the fill plug. Re-install the fill plug.

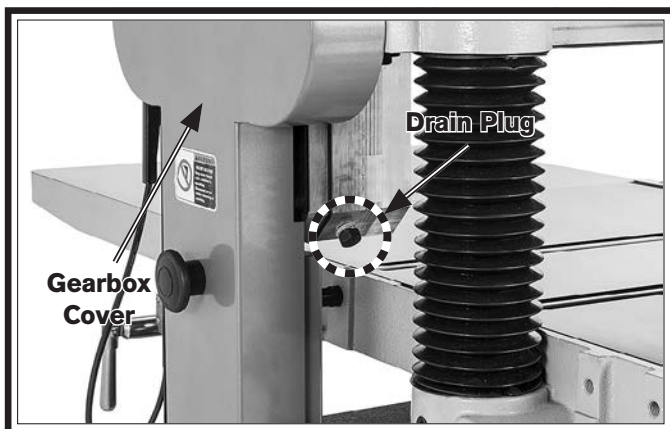

Figure 44. Location of gearbox oil drain plug.

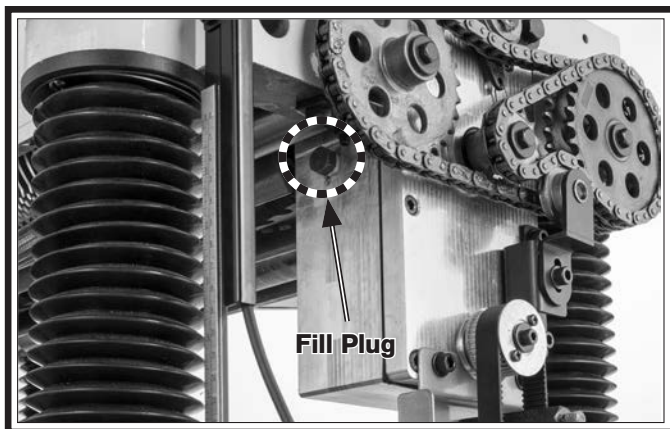

Figure 45. Location of gearbox oil fill plug.

## Anti-Kickback Fingers

The anti-kickback fingers are an important safety feature of your planer. The fingers hang from a rod suspended across the head casting and in front of the infeed roller, as shown. This design allows the workpiece to easily enter the planer but reduces the risk of kickback by digging into the workpiece if it moves backward.



Figure 46. Example of anti-kickback fingers.

Check the anti-kickback fingers regularly to ensure they swing freely and easily. If the fingers do not swing freely and easily, first clean them with a wood-resin solvent, then inspect them for damage. If any of the fingers are damaged, the device must be replaced before using the machine.

Do not apply oil or other lubricants to the anti-kickback fingers that will attract dust and restrict free movement of the fingers.

### **⚠️ WARNING**

Proper operation of anti-kickback fingers is critical for safe operation of this planer. **DO NOT** operate planer if anti-kickback fingers are not operating correctly. Failure to heed this warning could result in serious personal injury.

# Tensioning/Replacing V-Belts

Three V-belts transfer power from the motor to the cutterhead, and then to the infeed and outfeed rollers with the use of the drive chain system. To ensure efficient transfer of power to these systems, make sure the V-belts are always properly tensioned and in good condition.

If the V-belts are worn, cracked, or damaged, replace them. Always replace all V-belts at the same time with a matched set of three, or belt tension may not be even among the belts, causing premature belt failure or weakened power transfer.

Items Needed	Qty
Phillips Screwdriver #2 .....	1
Open-End Wrench 19mm .....	1

**⚠ CAUTION**

**V-belts and pulleys will be hot after operation. Allow them to cool before handling.**

### To tension/replace V-belts:

1. DISCONNECT MACHINE FROM POWER!
2. Remove V-belt cover from left side of machine to expose belts (see **Figure 47**).

**Note:** A collection of black belt dust at the bottom of the belt cover is normal during the life of the belts.



**Figure 47. V-belts and pulleys.**

3. Remove rear cabinet cover to access motor mount hex nuts (see **Figure 48**).

**Note:** SB1108 has (1) motor mount connecting rod, SB1109 has (2).

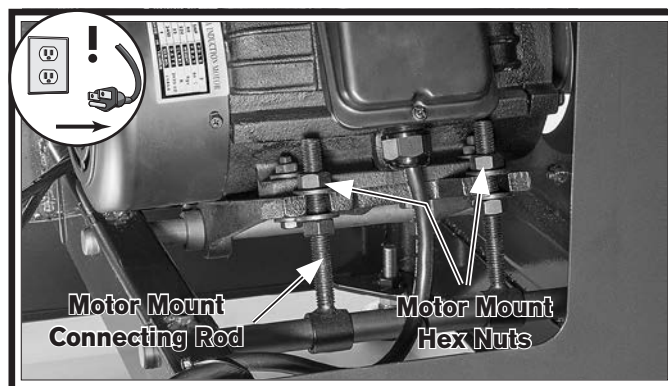

**Figure 48. Motor mount hex nuts.**

4. If V-belts need to be replaced, raise motor to release belt tension, roll them off pulleys, then replace with a matched set of three.
5. To adjust V-belt tension, loosen top motor mount hex nuts (see **Figure 48**), then adjust bottom hex nuts to raise or lower motor.

**Note:** V-belts are properly tensioned when there is approximately 3/4" deflection when moderate pressure is applied to them midway between pulleys, as illustrated in **Figure 49**.

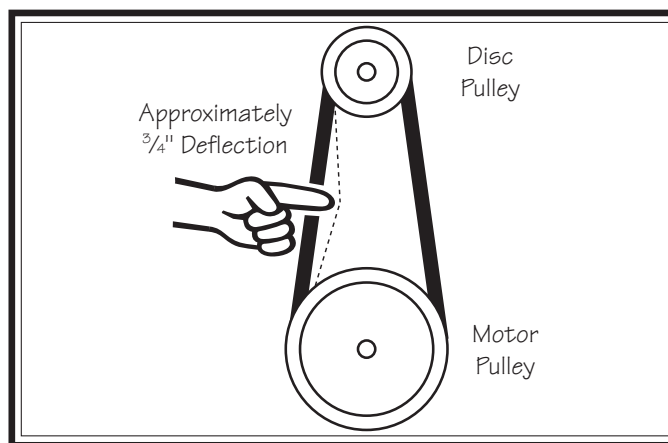

**Figure 49. Checking belt deflection.**

6. After V-belts are properly tensioned, tighten top motor mount hex nuts, then re-install cabinet cover and belt cover.



# Setting Feed Roller, Chip Breaker & Pressure Bar Heights

It is essential that the feed rollers, chip breaker, and pressure bar are set at the correct distance below the cutterhead knives/inserts at BDC (bottom dead center) to ensure that the workpiece moves through the planer evenly and the correct distance from the cutterhead knives/inserts.

To ensure accurate results and make the adjustment process quicker and easier, we recommend using a Rotacator for these adjustments (refer to **Page 32**).

If a Rotacator is not available, a 6' 2x4 cut into two even-sized pieces and a feeler gauge set can be used, but care must be taken when jointing the wood to achieve accurate results and ensure both boards have the exact same height.

### Dist. Below Cutterhead Insert at BDC (Figure 50)

- A. Infeed Roller.....0.040"
- B. Chip Breaker.....0.040"
- C. Pressure Bar.....0.008"
- D. Outfeed Roller.....0.020"

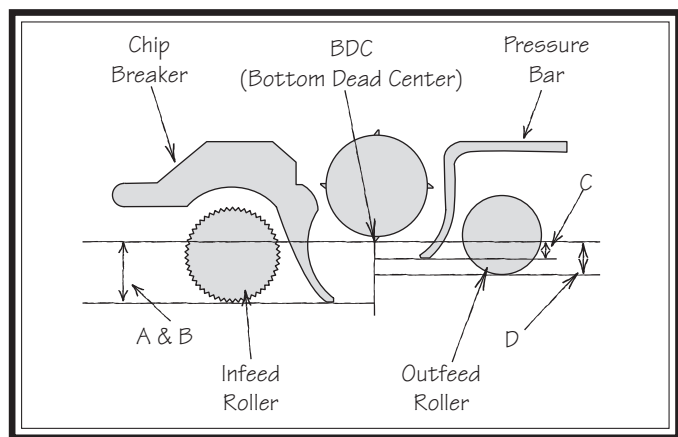

**Figure 50. Planer component recommended clearances.**

## Using a Rotacator

Items Needed	Qty
Hex Wrenches 3mm, 5mm.....	1 Ea.
Wrench or Socket 10mm.....	1 Ea.
Rotacator (see <b>Page 32</b> ) .....	1

### To use a Rotacator to check/adjust heights:

1. DISCONNECT MACHINE FROM POWER!
2. Make sure all inserts are properly installed (refer to **Rotating/Replacing Cutterhead Inserts** on **Page 30** for detailed instructions).
3. Lower table at least 4" below head casting, then lock it in place.
4. Remove dust hood, top cover, belt cover, and drive chain cover.
5. Using your Rotacator, find bottom dead center (BDC) of any insert edge by slowly rocking cutterhead pulley back and forth, then set Rotacator dial to "0" (see **Figure 51**).

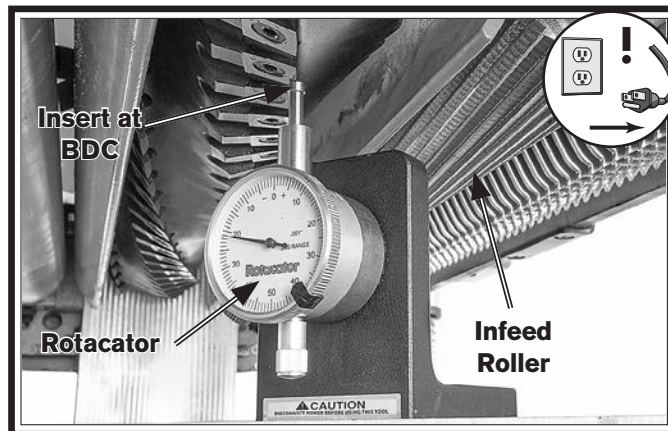

**Figure 51. Example of using a Rotacator to find BDC.**

6. Move feed rate control knob to neutral position to allow infeed roller to freely rotate.

7. Keeping Rotacator dial at "0", position it under right-hand side of infeed roller and find BDC of a serrated edge by rocking infeed roller back and forth.
8. Loosen jam nuts and use set screws on each side of feed roller as shown to adjust height of infeed roller bushing block until Rotacator dial shows 0.040", which is the recommended distance for infeed roller below the cutterhead (see **Figure 52**).

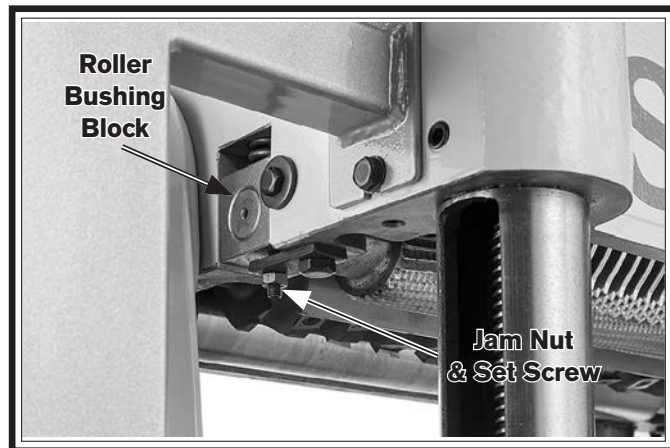

**Figure 52.** Location of infeed roller bushing block and height adjustment controls (left side shown).

9. Repeat **Steps 7-8** on left side of feed roller.
10. Re-check both sides of infeed roller and, if necessary, make further adjustments until infeed roller height from side to side is 0.040" below BDC of cutterhead insert, then retighten both jam nuts.
11. Keeping same "0" reference on Rotacator dial from **Step 5**, repeat **Steps 7-10** for outfeed roller, but adjust it until it is 0.020" below BDC of cutterhead insert.

12. Using same "0" reference on Rotacator dial from **Step 5**, perform similar steps as described previously to adjust height of chip breaker to its recommended specification given at beginning of this subsection. The adjustment controls are shown below (see **Figure 53**).

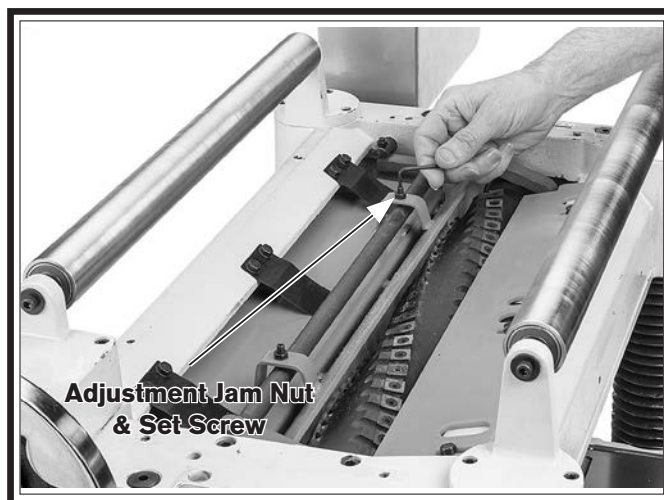

**Figure 53.** Adjusting chip breaker height.

13. Repeat **Step 12** for pressure bar height adjustment using adjustment controls shown in **Figure 54**.



**Figure 54.** Location of pressure bar height adjustment jam nut and set screw.

14. Re-install belt cover, top cover, chain cover, and dust hood.

## Using Wood Blocks

Items Needed	Qty
Hex Wrench 3mm, 5mm .....	1
Wrench or Socket 10mm.....	1
2x4 6' Long.....	1
Feeler Gauge Set.....	1

### To use wood blocks to check/adjust heights:

1. Build wood blocks by cutting a *straight* 6-foot-long 2x4 in half.

**Note:** *Having the wood blocks at an even height is critical to the accuracy of your overall adjustments. For best results, make the 2x4 square with a jointer and table saw before cutting it in half.*

2. **DISCONNECT MACHINE FROM POWER!**
3. Lower bed rollers below table surface (refer to **Bed Roller Height** on **Page 29** for detailed instructions).
4. Place wood blocks along sides of table, as illustrated in **Figure 55**, then raise table until blocks are close to cutterhead.

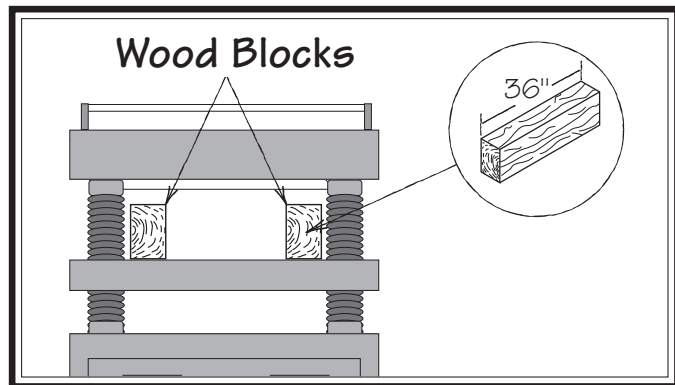
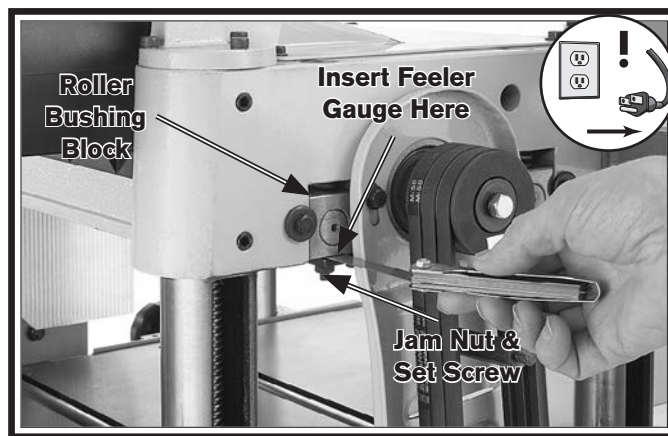

**Figure 55. Wood blocks properly positioned on the planer table.**

5. Remove dust hood, top cover, belt cover, and drive chain cover.
6. Using belt to rotate cutterhead, continue to raise table until blocks just barely touch cutterhead insert at its lowest point of rotation (BDC), then lock table in place.

**Note:** *The wood blocks will hold infeed and outfeed rollers, chip breaker, and pressure bar at same level as insert at BDC.*

7. Loosen jam nuts and set screws on each side of infeed roller (see **Figure 56**).
8. Using feeler gauge, adjust set screw so it is 0.040" from roller bushing block (see **Figure 56**), then tighten jam nut. Repeat on other side of infeed roller.



**Figure 56. Example of feeler gauge location for adjusting infeed roller height when using wood blocks (one of two locations shown).**

9. Repeat **Steps 8–9** with outfeed roller, only adjust the gaps to 0.020".
10. Loosen jam nuts and set screws on each side of chip breaker (see **Figure 57**).
11. Using a feeler gauge, adjust set screw so chip breaker is 0.040" from cross bar (see **Figure 57**), then tighten jam nut. Repeat on other side of chip breaker.

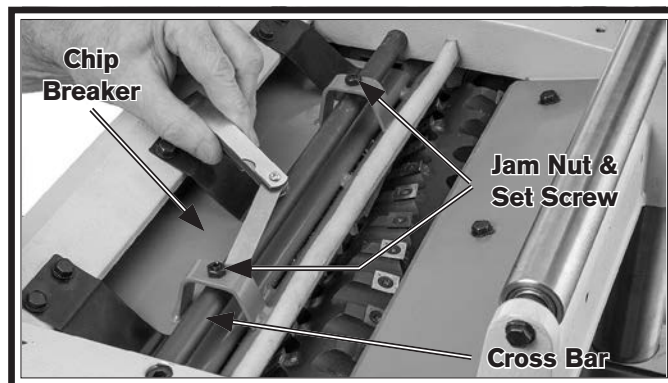

**Figure 57. Feeler gauge locations for adjusting chip breaker height when using wood blocks.**

12. Re-install belt cover, top cover, drive chain cover, and dust hood.



# Adjusting Feed-Roller Spring Tension

The infeed and outfeed rollers keep the workpiece moving through the planer. Springs exert downward pressure on the feed rollers while allowing them to raise with an uneven workpiece surface. Proper spring tension is crucial to keep the workpiece moving through the planer during operation without pulling from one side to the other.

The ideal feed-roller spring tension varies depending upon the type of wood you plane. When adjusting spring tension, keep the following in mind:

- If you are planing milled lumber with a consistent surface, use less spring tension to reduce the risk of marring the workpiece.
- If you are planing rough lumber with inconsistent surfaces, use greater spring tension to keep the stock moving through the planer.
- If the workpiece consistently stops feeding during operation, the spring tension may need to be increased.

<b>Items Needed</b>	<b>Qty</b>
Hex Wrench 5mm .....	1

### To adjust feed-roller spring tension:

1. DISCONNECT MACHINE FROM POWER!
2. Rotate tension screws clockwise to increase tension or counterclockwise to decrease tension (see **Figure 58**).



**Figure 58. Feed-roller spring tension adjustment screws.**

# Positioning Chip Deflector

Chip Deflector Gap Setting..... 1/16"– 1/4"

When properly distanced from the cutterhead, the chip deflector directs the chips into the dust hood, and keeps them from falling onto the outfeed roller and being pressed into the workpiece.

<b>Tools Needed</b>	<b>Qty</b>
Wrench or Socket 10mm.....	1
Hex Wrench 5mm .....	1

### To adjust chip deflector gap:

1. DISCONNECT MACHINE FROM POWER!
2. Remove dust hood, top cover, and belt cover.
3. Use cutterhead pulley to rotate cutterhead until an insert reaches closest distance to chip deflector (see **Figure 59**), then measure distance between insert and chip deflector.

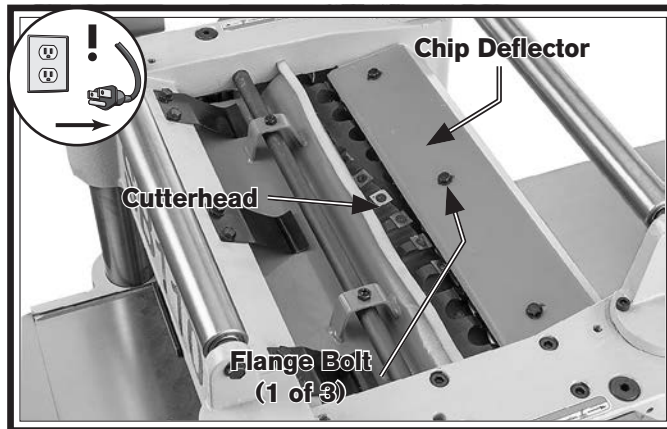

**Figure 59. Location of chip deflector and mounting hardware.**

4. If distance measured in **Step 3** is *not* equal to correct chip deflector gap setting, then loosen (3) flange bolts that secure chip deflector and adjust gap to correct setting.
5. Re-tighten flange bolts, then replace belt cover, top cover, and dust hood.

# Calibrating Table Height Scale

Although correctly set at the factory, the table height scale can be adjusted for accuracy if it becomes necessary.

<b>Items Needed</b>	<b>Qty</b>
Hex Wrench 4mm .....	1

**To calibrate table height scale:**

1. Raise table all the way up.
2. Loosen scale pointer cap screw shown in **Figure 60**.
3. Adjust scale pointer to 1/4" mark on scale, then tighten cap screw (see **Figure 60**).

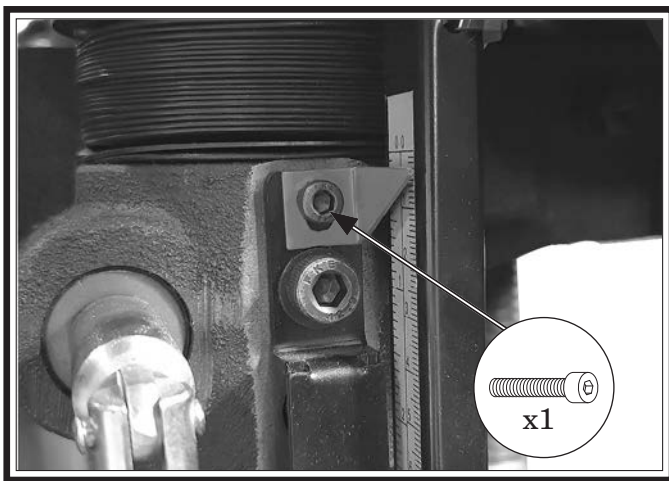

**Figure 60.** Location of adjustment screw for table height scale.

# Replacing Feed Motor Brushes

The models SB1108 and SB1109 feature a DC motor that is used to control the feed rollers, which uses heavy-duty carbon brushes. While these brushes are design for extended life, they will eventually wear out, causing loss of power or faulty starting..

<b>Items Needed</b>	<b>Qty</b>
Phillips Screwdriver #2 .....	1
Flat Head Screwdriver.....	1
Motor Brushes.....	1 Set

**To replace feed motor brushes:**

1. **DISCONNECT MACHINE FROM POWER!**
2. Remove motor access panel.
3. Remove DC motor brush cover, then pull out used motor brush (see **Figure 61**).

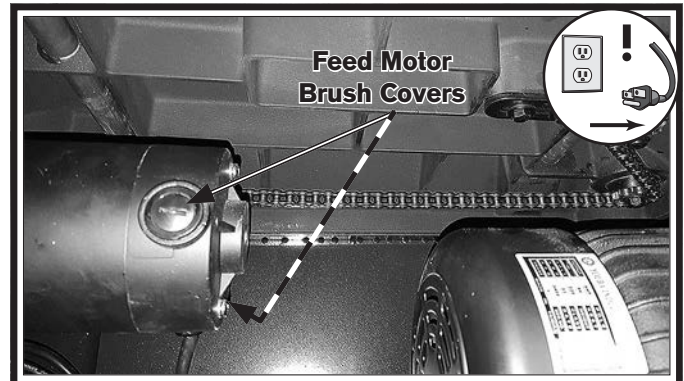

**Figure 61.** Feed motor brush location.

4. Insert new motor brush, then re-install and tighten brush cover.
5. Repeat **Step 4** to replace second motor brush.
6. Re-install motor access cover.



# Checking Pulley Alignment

Proper pulley alignment prevents premature V-belt wear and proper power transfer from the motor. The pulleys are properly aligned when they are parallel and in the same plane as each other.

Items Needed	Qty
Straightedge 3' .....	1
Wrench or Socket 14mm, 17mm .....	2 Ea.

### To check/re-align pulleys:

1. DISCONNECT MACHINE FROM POWER!
2. Remove belt cover, then use straightedge to check pulley alignment, as shown in **Figure 62**.



**Figure 62. Checking pulley alignment.**

- If pulleys are parallel and in the same plane, no adjustment is necessary. Re-install belt cover.
  - If pulleys are not parallel or in the same plane, remove motor access panel, then proceed to **Step 3**.
3. Loosen (4) motor mount bolts, shift motor until pulleys are aligned, then re-tighten bolts.
  4. Re-check pulleys and repeat **Step 3** as necessary until you are satisfied with pulley alignment, then re-tighten all fasteners, and replace belt cover and motor access panel.

# Tensioning Table Height Chain

The table height chain is located under the table. It transfers movement from the handwheel to the columns that control table height. The chain drive can be adjusted to remove slack if the chain stretches over time or is loosened during table leveling procedures.

Items Needed	Qty
Phillips Screwdriver #2 .....	1
Wrench or Socket 14mm.....	1

### To tension table height chain:

1. DISCONNECT MACHINE FROM POWER!
2. Remove motor access panel to access table height chain (see **Figure 63**).
3. Loosen both chain-tension lock bolts (see **Figure 63**), then push idler sprocket against chain with moderate pressure to eliminate slack in chain. While maintaining pressure on idler sprocket, re-tighten lock bolts.

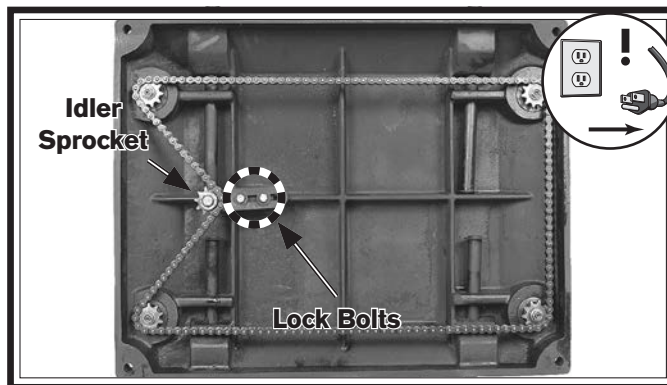

**Figure 63. Location of idler sprocket and chain tension lock bolts.**

4. Clean and lubricate chain and sprockets (refer to **Table Height Chain & Sprockets** on **Page 36** for detailed instructions), then re-install motor access panel.

**NOTICE**

**DO NOT let chain fall off sprockets. It can be very difficult to return chain to its proper location on sprockets without changing table adjustments.**

# Adjusting Table Parallelism

## Maximum Allowable Tolerances

Cutterhead/Table Side-to-Side .....	0.002"
Head Casting/Table Front/Back.....	0.020"

## Tools Needed

	Qty
Rotacator .....	1
Phillips Screwdriver #2 .....	1
Wrench or Socket 14mm.....	1
Hex Wrench 6mm .....	1

Table parallelism is critical to the operation of the machine. As such, it is essential that the table is adjusted parallel with the cutterhead (within 0.002") from side-to-side, as illustrated in **Figure 64**.

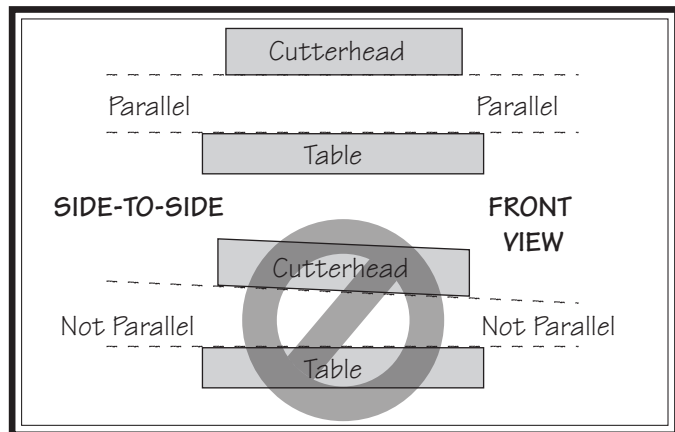

**Figure 64. Side-to-side parallelism of table and cutterhead.**

How the table sits in relation to the head casting from front-to-back is also important. Because the feed rollers, pressure bar, and chip breaker are adjusted off the table position, the tolerances on the front-to-back positioning are not as critical as the cutterhead/table side-to-side positioning. Therefore, the maximum allowable tolerance for the front-to-back parallelism is within 0.020" (see **Figure 65**).

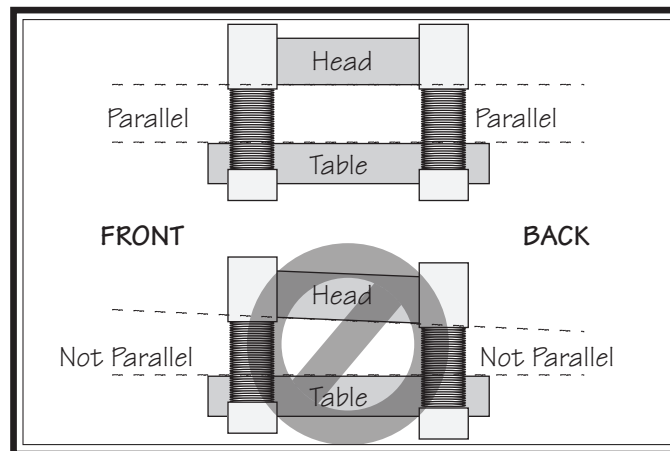

**Figure 65. Front-to-back parallelism of table and cutterhead.**

## Table Parallelism Inspection

The easiest way to determine if your head casting has a parallelism problem is to plane a workpiece and measure the thickness in multiple locations. If the workpiece is tapered from left-to-right or from front-to-back, then parallelism may be a problem.

Use your Rotacator to further inspect the table parallelism. If you do not have a Rotacator, a wood block and feeler gauges may be used, but extra care must be taken to ensure accuracy. If the table is not within the maximum allowable tolerances, it must be adjusted.

## Table Parallelism Adjustments

The table is adjusted by turning the chain sprockets underneath the table for movements over 0.016" or by adjusting how the table is mounted on the columns for movements under 0.016".

### NOTICE

**When making adjustments, tighten fasteners after each step to ensure the accuracy of your tests. When adjusting the chain sprockets, keep in mind that if the chain becomes too loose, it will fall off of all the sprockets, and returning it to its proper location can be extremely difficult.**

#### To adjust table parallelism:

1. DISCONNECT MACHINE FROM POWER!
2. Remove motor access panel and locate chain on underside of table.
3. Loosen lock bolts and idler sprocket (see **Figure 66**).

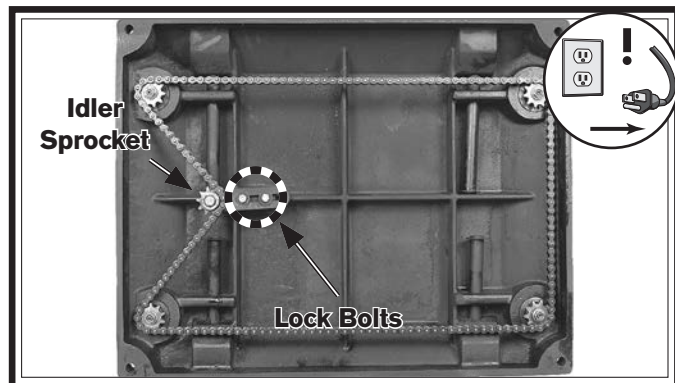

**Figure 66.** Location of idler sprocket and chain tension lock bolts.

4. Move chain away from sprocket you want to adjust so only that sprocket can be rotated independent of chain.

**Note:** *If the left side of the table is too high, the left two sprockets will need to be adjusted. Each tooth on the sprocket represents 0.016" of vertical movement as the cogs are turned. Make sure, as you turn the sprockets, to keep an accurate tooth count to ensure that the table is adjusted equally.*

5. Mark location of one tooth of sprocket that you are adjusting.
6. Carefully rotate sprocket (clockwise to lower table; counterclockwise to raise table) just enough to position next tooth at marked location, then fit chain around sprocket again.
7. Repeat **Steps 4–6** with each sprocket that needs to be adjusted until table-to-cutterhead clearance is within 0.016" from one side to the other.
8. Make sure chain is properly fitted on sprockets, then re-tighten idler sprocket and lock bolts.
9. If necessary, micro-adjust table position by loosening cap screws (see **Figure 67**) and raising or lowering table until it is properly aligned with cutterhead.

**Note:** *This process may require adjusting the columns on both the left and right hand sides until you find the correct combination.*

10. Re-tension table height chain (see **Tensioning Table Height Chain** instructions on **Page 44**).

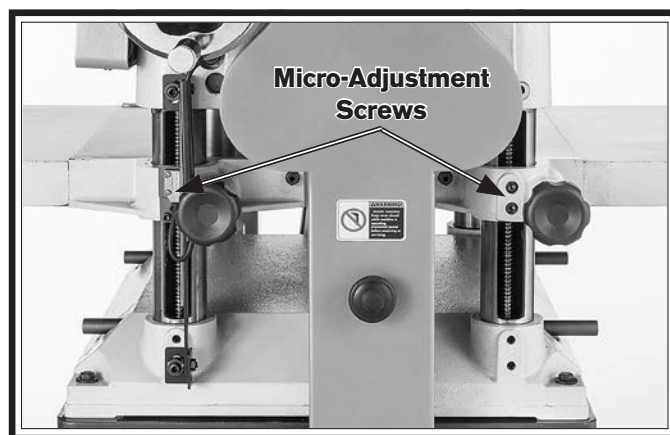

**Figure 67.** Location of table micro-adjustment screws (only one side shown).

If you need replacement parts, or if you are unsure how to do any of the solutions given here, feel free to call us at (360) 734-1540.

Symptom	Possible Cause	Possible Solution
Machine does not start or power supply breaker immediately trips after startup.	<ol style="list-style-type: none"> <li>1. EMERGENCY STOP button depressed/at fault.</li> <li>2. Machine circuit breaker tripped.</li> <li>3. Incorrect power supply voltage or circuit size.</li> <li>4. Power supply circuit breaker tripped or fuse blown.</li> <li>5. Thermal overload relay has tripped/at fault.</li> <li>6. Start capacitor at fault.</li> <li>7. Contactor not energized/at fault.</li> <li>8. Wiring broken, disconnected, or corroded.</li> <li>9. Start button or circuit breaker switch at fault.</li> <li>10. Centrifugal switch adjustment/contact points at fault.</li> <li>11. Pulse width modulator circuit board at fault.</li> <li>12. Motor or motor bearings at fault.</li> </ol>	<ol style="list-style-type: none"> <li>1. Rotate EMERGENCY STOP button head to reset. Replace if at fault.</li> <li>2. Reset circuit breaker on control panel.</li> <li>3. Ensure correct power supply voltage and circuit size.</li> <li>4. Ensure circuit is free of shorts. Reset circuit breaker or replace fuse.</li> <li>5. Reset. Adjust or replace if at fault.</li> <li>6. Test/replace if at fault.</li> <li>7. Test all legs for power; replace if necessary.</li> <li>8. Fix broken wires or disconnected/corroded connections.</li> <li>9. Replace button/circuit breaker switch.</li> <li>10. Adjust centrifugal switch/clean contact points. Replace either if at fault.</li> <li>11. Inspect; replace if at fault.</li> <li>12. Replace motor.</li> </ol>
Machine stalls or is underpowered.	<ol style="list-style-type: none"> <li>1. Workpiece material not suitable for machine.</li> <li>2. Feed rate/cutting speed too fast.</li> <li>3. Belts slipping/pulleys misaligned.</li> <li>4. Pulley/sprocket slipping on shaft.</li> <li>5. Machine undersized for task.</li> <li>6. Motor overheated, tripping machine circuit breaker.</li> <li>7. Run capacitor at fault.</li> <li>8. Extension cord too long.</li> <li>9. Contactor not energized/at fault.</li> <li>10. Centrifugal switch/contact points at fault.</li> <li>11. Motor or motor bearings at fault.</li> </ol>	<ol style="list-style-type: none"> <li>1. Only cut wood/ensure moisture is below 20% (<b>Page 25</b>).</li> <li>2. Decrease feed rate/cutting speed (<b>Page 28</b>).</li> <li>3. Clean/tension/replace belts (<b>Page 38</b>) ; ensure pulleys are aligned (<b>Page 44</b>).</li> <li>4. Tighten/replace loose pulley/shaft.</li> <li>5. Use sharp inserts; reduce feed rate/depth of cut.</li> <li>6. Clean motor/let cool, and reduce workload. Reset breaker.</li> <li>7. Test/repair/replace.</li> <li>8. Move machine closer to power supply; use shorter extension cord.</li> <li>9. Test all legs for power; repair/replace if at fault.</li> <li>10. Adjust centrifugal switch/clean contact points. Replace either if at fault.</li> <li>11. Replace motor.</li> </ol>
Feed motor does not start or stalls.	<ol style="list-style-type: none"> <li>1. Motor brushes worn out.</li> </ol>	<ol style="list-style-type: none"> <li>1. Replace motor brushes (<b>Page 43</b>).</li> </ol>

Symptom	Possible Cause	Possible Solution
Machine has excessive vibration or noisy operation.	<ol style="list-style-type: none"> <li>1. Motor or component loose.</li> <li>2. Machine feet not adjusted properly.</li> <li>3. V-belts worn, loose, pulleys misaligned or belt slapping cover.</li> <li>4. Cutterhead inserts at fault.</li> <li>5. Pulley loose.</li> <li>6. Motor mount loose/broken.</li> <li>7. Motor fan rubbing on fan cover.</li> <li>8. Bed rollers protruding unevenly.</li> <li>9. Cutterhead bearings at fault.</li> <li>10. Centrifugal switch.</li> <li>11. Motor bearings at fault.</li> <li>12. Plastic chip deflector hitting inserts.</li> </ol>	<ol style="list-style-type: none"> <li>1. Replace damaged or missing bolts/nuts or tighten if loose.</li> <li>2. Adjust machine feet to stabilize machine.</li> <li>3. Inspect/replace belts with a new matched set (<b>Page 38</b>). Realign pulleys if necessary (<b>Page 44</b>).</li> <li>4. Rotate/replace inserts (<b>Page 30</b>).</li> <li>5. Secure pulley on shaft.</li> <li>6. Tighten/replace.</li> <li>7. Fix/replace fan cover; replace loose/damaged fan.</li> <li>8. Adjust bed rollers (<b>Page 29</b>).</li> <li>9. Replace bearing(s)/realign cutterhead.</li> <li>10. Test/repair/replace.</li> <li>11. Test by rotating shaft; rotational grinding/loose shaft requires bearing replacement.</li> <li>12. Replace chip deflector and realign (<b>Page 42</b>).</li> </ol>
Table is hard to adjust.	<ol style="list-style-type: none"> <li>1. Table locks are engaged or partially engaged.</li> </ol>	<ol style="list-style-type: none"> <li>1. Completely loosen table locks.</li> </ol>
Workpiece stops/slow in the middle of cut.	<ol style="list-style-type: none"> <li>1. Depth of cut too deep.</li> <li>2. Pitch and glue build-up on planer components.</li> <li>3. One or both bed rollers are set too low.</li> <li>4. Chip breaker or pressure bar set too low.</li> <li>5. Feed rollers set too low or too high.</li> </ol>	<ol style="list-style-type: none"> <li>1. Reduce depth of cut (<b>Page 28</b>).</li> <li>2. Clean planer components with a pitch/resin dissolving solvent.</li> <li>3. Raise height of bed rollers (<b>Page 29</b>).</li> <li>4. Raise height of chip breaker or pressure bar (<b>Page 39</b>).</li> <li>5. Adjust feed rollers to correct height (<b>Page 39</b>).</li> </ol>
<p>Excessive snipe (gouge at the end of workpiece that is uneven with the rest of cut).</p> <p><b>Note:</b> A small amount of snipe is inevitable with all types of planers—the key is to minimize it.</p>	<ol style="list-style-type: none"> <li>1. One or both bed rollers are set too high.</li> <li>2. Rear extension table slopes down or is not level with main table.</li> <li>3. Chip breaker, feed roller, or pressure bar set too low.</li> <li>4. Workpiece is not properly supported as it leaves planer.</li> </ol>	<ol style="list-style-type: none"> <li>1. Lower height of bed rollers (<b>Page 29</b>).</li> <li>2. Adjust rear extension table set screws to make extension table level with main table (<b>Page 19</b>).</li> <li>3. Adjust height of chip breaker, feed roller, or pressure bar (<b>Page 39</b>).</li> <li>4. Use an assistant or roller beds/stands to properly support workpiece as it leaves planer.</li> </ol>



Symptom	Possible Cause	Possible Solution
Consistent chipping pattern.	<ol style="list-style-type: none"> <li>1. Knots or conflicting grain direction in workpiece.</li> <li>2. Nicked, chipped, or dull insert.</li> <li>3. Feed rate too fast.</li> <li>4. Depth of cut too deep.</li> <li>5. Bed rollers set too high or low; not even with each other.</li> <li>6. Misaligned chip breaker.</li> </ol>	<ol style="list-style-type: none"> <li>1. Inspect workpiece for knots and grain direction; use only clean stock (<b>Page 25</b>).</li> <li>2. Rotate/replace insert (<b>Page 30</b>).</li> <li>3. Reduce feed rate (<b>Page 28</b>).</li> <li>4. Reduce depth of cut (<b>Page 28</b>).</li> <li>5. Properly adjust bed roller height (<b>Page 29</b>).</li> <li>6. Adjust both sides of chip breaker to correct height (<b>Page 39</b>).</li> </ol>
Fuzzy grain.	<ol style="list-style-type: none"> <li>1. Workpiece has high moisture content or surface wetness.</li> <li>2. Dull inserts.</li> </ol>	<ol style="list-style-type: none"> <li>1. Allow workpiece to dry if moisture content is over 20% or has high surface wetness.</li> <li>2. Rotate/replace inserts (<b>Page 30</b>).</li> </ol>
Glossy surface.	<ol style="list-style-type: none"> <li>1. Inserts are dull.</li> <li>2. Feeding workpiece too slow.</li> <li>3. Cutting depth too shallow.</li> </ol>	<ol style="list-style-type: none"> <li>1. Rotate/replace inserts (<b>Page 30</b>).</li> <li>2. Increase feed rate (<b>Page 28</b>).</li> <li>3. Increase depth of cut (<b>Page 28</b>).</li> </ol>
Long lines or ridges that run the length of workpiece.	<ol style="list-style-type: none"> <li>1. Nicked or chipped inserts.</li> </ol>	<ol style="list-style-type: none"> <li>1. Rotate/replace inserts (<b>Page 30</b>).</li> </ol>
Uneven cutting marks, wavy surface, or chatter marks across face of workpiece.	<ol style="list-style-type: none"> <li>1. Feed rate too fast.</li> <li>2. Chip breaker or pressure bar set unevenly.</li> <li>3. Bed rollers set too high or low; not even with each other.</li> <li>4. Insert(s) not properly installed.</li> <li>5. Worn cutterhead bearings.</li> </ol>	<ol style="list-style-type: none"> <li>1. Reduce feed rate (<b>Page 28</b>).</li> <li>2. Adjust height of chip breaker or pressure bar (<b>Page 39</b>).</li> <li>3. Properly adjust bed roller height (<b>Page 29</b>).</li> <li>4. Remove insert(s), then properly clean and re-install (<b>Page 30</b>).</li> <li>5. Replace cutterhead bearings.</li> </ol>
Inconsistent chip marks.	<ol style="list-style-type: none"> <li>1. Chips are not being properly expelled from around cutterhead.</li> </ol>	<ol style="list-style-type: none"> <li>1. Use an adequate dust collection system; adjust chip deflector in or out, depending on your setup (<b>Page 39</b>).</li> </ol>
Workpiece twists in machine.	<ol style="list-style-type: none"> <li>1. Pressure bar set unevenly.</li> <li>2. Bed rollers not parallel with table.</li> </ol>	<ol style="list-style-type: none"> <li>1. Adjust height of pressure bar (<b>Page 39</b>).</li> <li>2. Adjust bed roller height (<b>Page 29</b>).</li> </ol>

# Electrical Safety Instructions

These pages are accurate at the time of printing. In the constant effort to improve, however, we may make changes to the electrical systems of future machines. Study this section carefully. If you see differences between your machine and what is shown in this section, call Technical Support at (360) 734-1540 for assistance BEFORE making any changes to the wiring on your machine.

**Shock Hazard:** It is extremely dangerous to perform electrical or wiring tasks while the machine is connected to the power source. Touching electrified parts will result in personal injury including but not limited to severe burns, electrocution, or death. For your own safety, disconnect machine from the power source before servicing electrical components or performing any wiring tasks!

**Wire Connections:** All connections must be tight to prevent wires from loosening during machine operation. Double-check all wires disconnected or connected during any wiring task to ensure tight connections.

**Modifications:** Using aftermarket parts or modifying the wiring beyond what is shown in the diagram may lead to unpredictable results, including serious injury or fire.

**Motor Wiring:** The motor wiring shown in these diagrams is current at the time of printing, but it may not match your machine. Always use the wiring diagram inside the motor junction box.

**Circuit Requirements:** Connecting the machine to an improperly sized circuit will greatly increase the risk of fire. To minimize this risk, only connect the machine to a power circuit that meets the minimum requirements given in this manual.

**Capacitors/Inverters:** Some capacitors and power inverters store an electrical charge for up to 10 minutes after being disconnected from the power source. To reduce the risk of being shocked, wait at least this long before working on capacitors.

**Wire/Component Damage:** Damaged wires or components increase the risk of serious personal injury, fire, or machine damage. If you notice that any wires or components are damaged while performing a wiring task, replace those wires or components before completing the task.

**Experiencing Difficulties:** If you are experiencing difficulties understanding the information included in this section, contact our Technical Support at (360) 734-1540.

## WIRING DIAGRAM COLOR KEY

BLACK — Bk	BLUE WHITE — Bw	RED — Rd	PINK — Pk	WHITE — Wt
BLUE — Bl	GREEN — Gn	LIGHT BLUE — Lb	PURPLE — Pu	YELLOW GREEN — Yg
BROWN — Br	GRAY — Gy	ORANGE — Or	TUR-QUIOSE — Tu	YELLOW — Yl

**NOTICE:** The photos and diagrams included in this section are best viewed in color. You can see them in color at [www.southbendtools.com](http://www.southbendtools.com).

# SB1108 Wiring Diagram

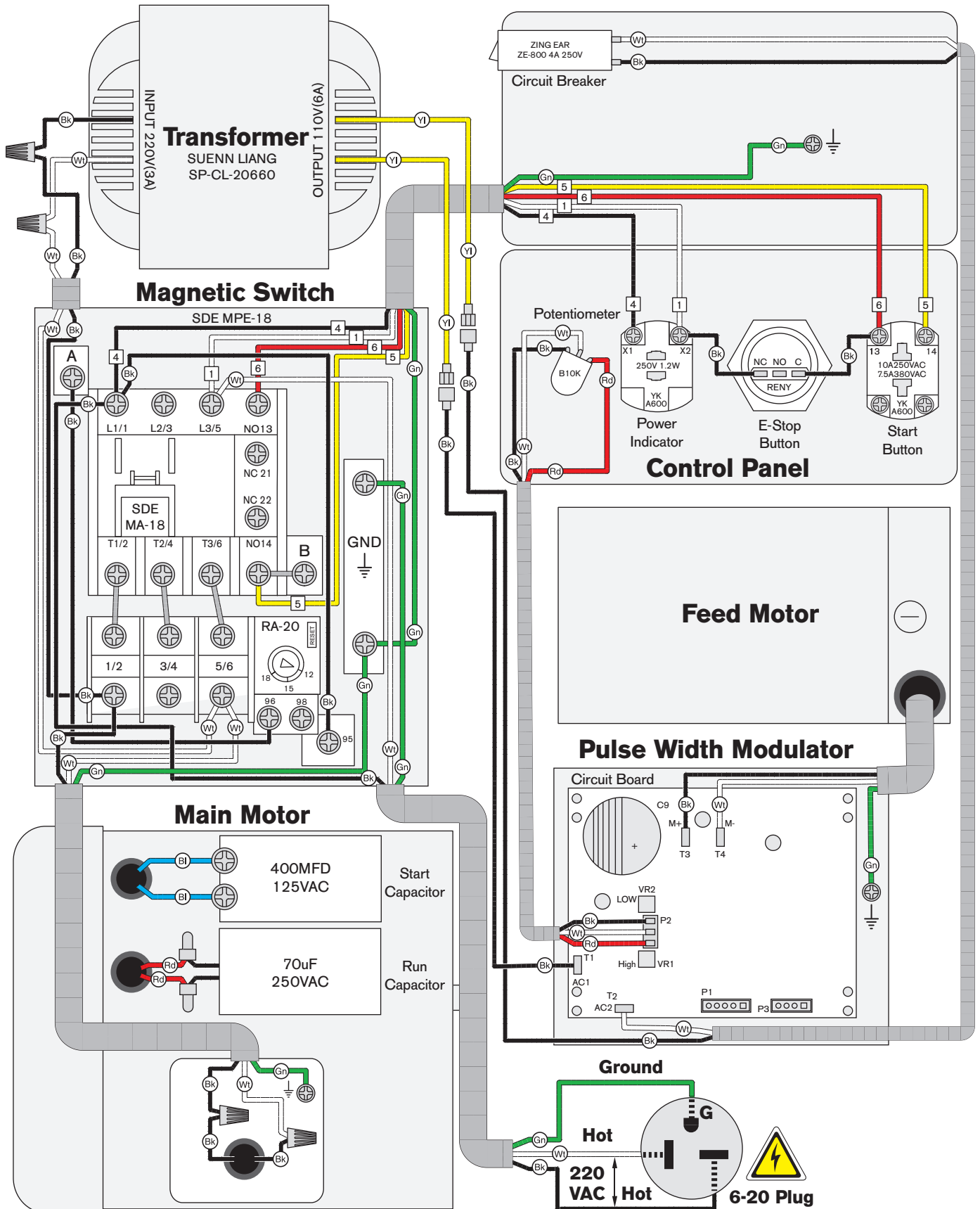

# SB1108 Electrical Component Photos



Figure 68. SB1108 start capacitor.



Figure 69. SB1108 run capacitor.



Figure 70. SB1108 motor junction box.



Figure 71. SB1108 mag switch, transformer, & pulse width modulator.

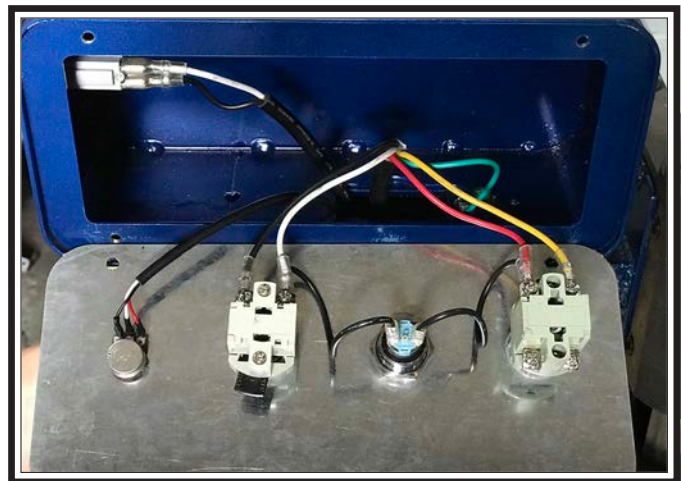

Figure 72. SB1108 control panel.



# SB1108 Height DRO Wiring Diagram

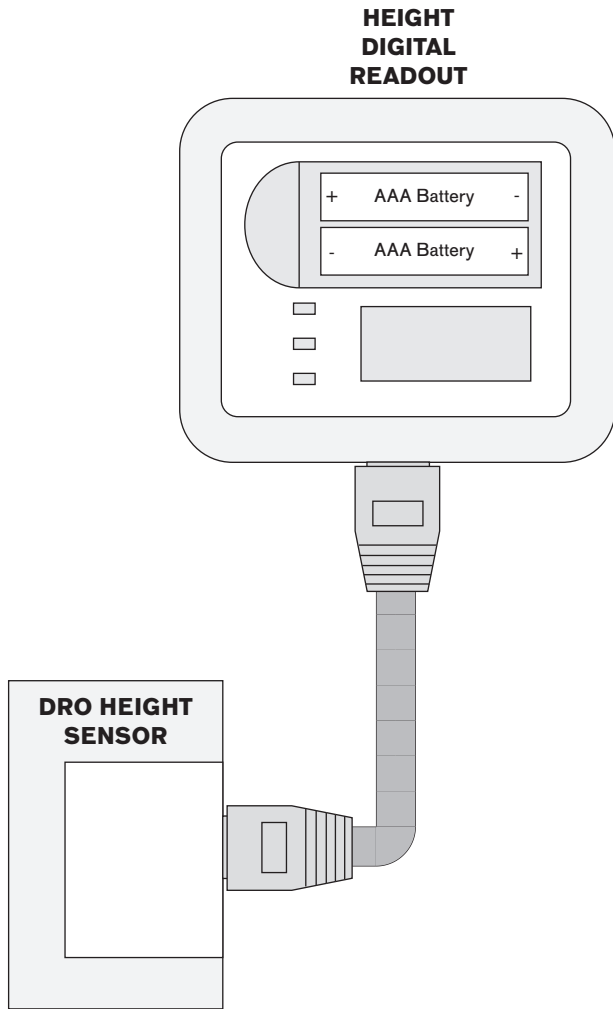

Figure 73. SB1108 height digital readout.

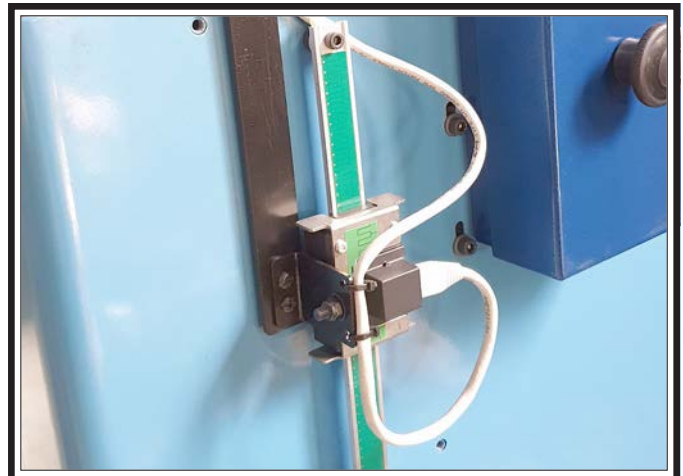
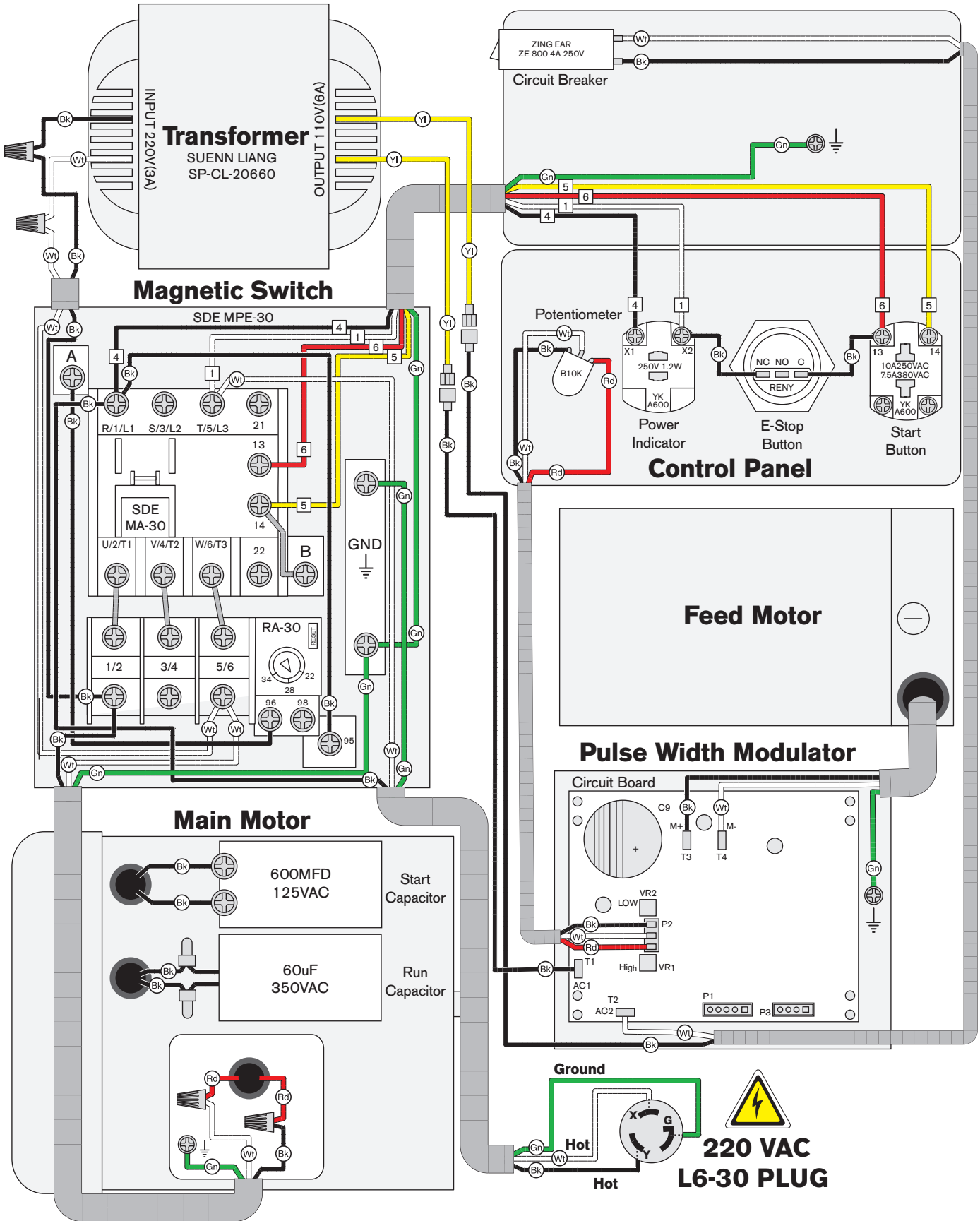

Figure 74. SB1108 DRO height sensor.



# SB1109 Wiring Diagram



# SB1109 Electrical Component Photos



Figure 75. SB1109 start capacitor.

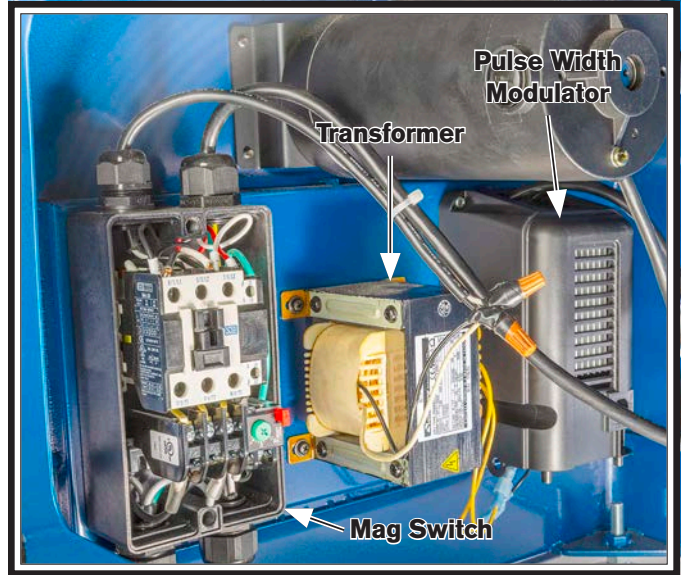

Figure 78. SB1109 mag switch, transformer, & pulse width modulator.



Figure 76. SB1109 run capacitor.

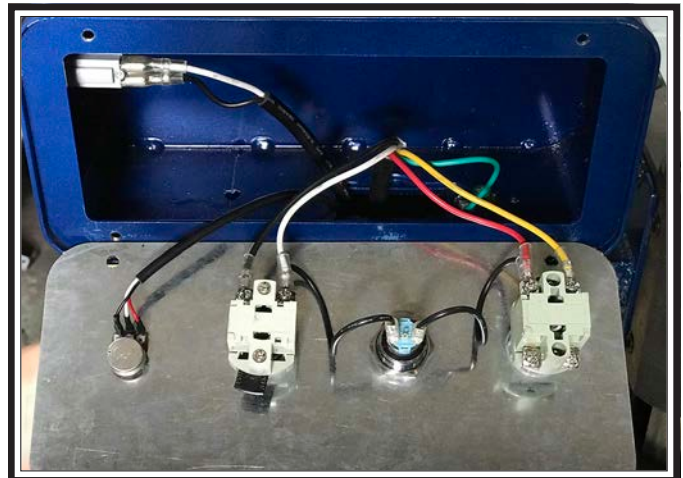

Figure 79. SB1109 control panel.



Figure 77. SB1109 motor junction box.

# SB1109 Height DRO Wiring Diagram

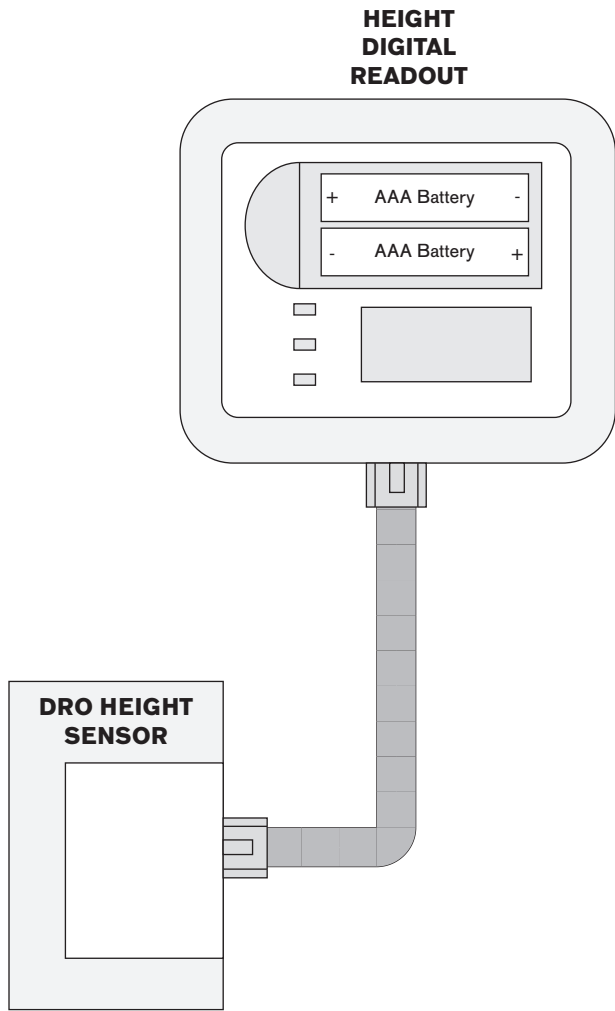
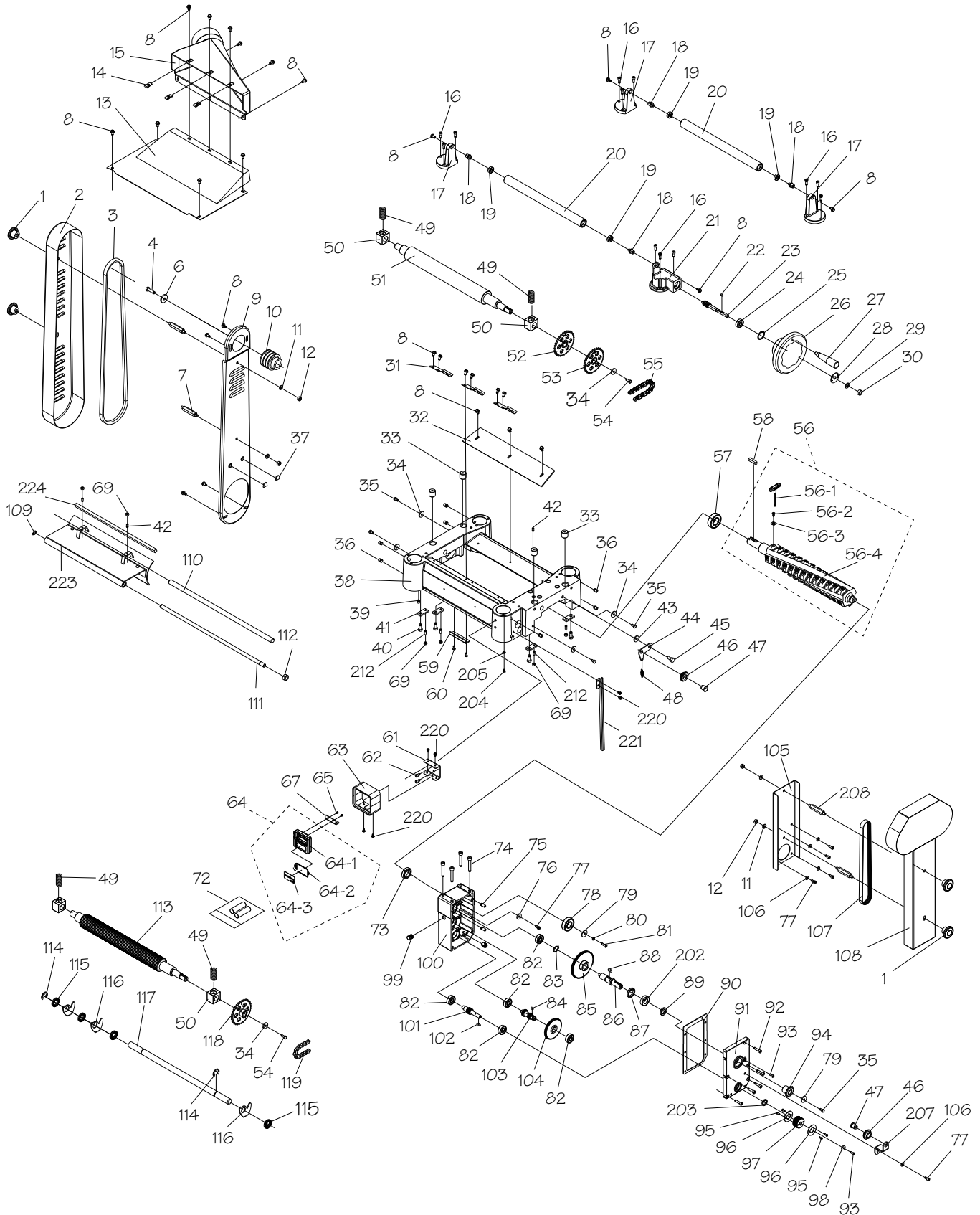

Figure 80. SB1109 height digital readout.



Figure 81. SB1109 DRO height sensor.

# SB1108 Main





# SB1108 Main Parts List

REF	PART #	DESCRIPTION
1	PSB1108001	KNOB 5/16-18 LOBED
2	PSB1108002	BELT PULLEY COVER
3	PSB1108003	V-BELT M58
4	PSB1108004	HEX BOLT M8-1.25 X 30
6	PSB1108006	FENDER WASHER 8MM
7	PSB1108007	STANDOFF-HEX MM 5.16-18 X 2-1/4, 3/8
8	PSB1108008	FLANGE BOLT M6-1 X 12
9	PSB1108009	BELT PULLEY GUARD
10	PSB1108010	PULLEY
11	PSB1108011	FLAT WASHER 8MM
12	PSB1108012	HEX NUT 5/16-18
13	PSB1108013	UPPER COVER
14	PSB1108014	CLIP-ON NUT M6-1
15	PSB1108015	DUST HOOD W/4" PORT
16	PSB1108016	CAP SCREW M6-1 X 20
17	PSB1108017	RETURN ROLLER BRACKET
18	PSB1108018	BEARING SHAFT
19	PSB1108019	BALL BEARING 608Z
20	PSB1108020	RETURN ROLLER
21	PSB1108021	WORM GEAR HOUSING
22	PSB1108022	KEY 4 X 4 X 10 RE
23	PSB1108023	WORM SHAFT
24	PSB1108024	BALL BEARING 6200Z
25	PSB1108025	INT RETAINING RING 30MM
26	PSB1108026	HANDWHEEL TYPE-11 150D X 10B-K X 3/8-16
27	PSB1108027	REVOLVING HANDLE 3/8-16 X 1/2
28	PSB1108028	DIRECTION LABEL
29	PSB1108029	FLAT WASHER 10MM
30	PSB1108030	HEX NUT M10-1.25
31	PSB1108031	SPRING PLATE
32	PSB1108032	CHIP DEFLECTOR
33	PSB1108033	OILER SCREW M22-1.5 X 20
34	PSB1108034	FENDER WASHER 6MM
35	PSB1108035	HEX BOLT M6-1 X 12
36	PSB1108036	SET SCREW M10-1.5 X 12
37	PSB1108037	PLATE
38	PSB1108038	HEAD CASTING
39	PSB1108039	SET SCREW M8-1.25 X 10
40	PSB1108040	HEX BOLT M8-1.25 X 20
41	PSB1108041	PLATE
42	PSB1108042	SET SCREW M6-1 X 12
43	PSB1108043	FENDER WASHER 8MM
44	PSB1108044	CHAIN TENSIONER
45	PSB1108045	SHOULDER BOLT M8-1.25 X 14.5, 4 X 12
46	PSB1108046	IDLER WHEEL
47	PSB1108047	IDLER SHAFT
48	PSB1108048	EXTENSION SPRING 1 X 8.5 X 35
49	PSB1108049	COMPRESSION SPRING 3.5 X 19.7 X 70
50	PSB1108050	COMPRESSION SPRING BUSHING BLOCK
51	PSB1108051	OUTFEED ROLLER
52	PSB1108052	SPROCKET SIZE 31T

REF	PART #	DESCRIPTION
53	PSB1108053	SPROCKET SIZE 31T
54	PSB1108054	HEX BOLT M6-1 X 16
55	PSB1108055	CHAIN #06B X 40P
56	PSB1108056	HELICAL CUTTERHEAD ASSY
56-1	PSB1108056-1	T-HANDLE TORX DRIVER T25
56-2	PSB1108056-2	FLAT HD TORX 10-32 X 1/2
56-3	PSB1108056-3	INSERT 15 X 15 X 2.5MM-10 PK
56-4	PSB1108056-4	HELICAL CUTTERHEAD 15"
57	PSB1108057	BALL BEARING 6205-2NSE
58	PSB1108058	KEY 8 X 8 X 36 RE
59	PSB1108059	DEPTH LIMITER
60	PSB1108060	FLAT HD SCR M5-.8 X 12
61	PSB1108061	DIGITAL READOUT BRACKET
62	PSB1108062	CAP SCREW M6-1 X 10
63	PSB1108063	DIGITAL READOUT HOUSING
64	PSB1108064	DIGITAL READOUT ASSEMBLY
64-1	PSB1108064-1	DIGITAL READOUT WIXEY WR5502
64-2	PSB1108064-2	BATTERY COVER
64-3	PSB1108064-3	BATTERY COVER DECAL
65	PSB1108065	TAP SCREW M3 X 8
67	PSB1108067	MOUNTING PLATE
69	PSB1108069	HEX NUT M6-1
72	PSB1108072	BATTERY AAA (2PC)
73	PSB1108073	OIL SEAL 28 X 40 X 8
74	PSB1108074	CAP SCREW M8-1.25 X 50
75	PSB1108075	ROLL PIN 8 X 20
76	PSB1108076	FENDER WASHER 6MM
77	PSB1108077	CAP SCREW M6-1 X 12
78	PSB1108078	BALL BEARING 6204-2NSE
79	PSB1108079	FENDER WASHER 6MM
80	PSB1108080	LOCK WASHER 6MM
81	PSB1108081	CAP SCREW M6-1 X 16
82	PSB1108082	BALL BEARING 6201ZZ
83	PSB1108083	EXT RETAINING RING 20MM
84	PSB1108084	KEY 5 X 5 X 10 RE
85	PSB1108085	GEAR 96T
86	PSB1108086	SHAFT SIZE 24.5 X 105
87	PSB1108087	OIL SEAL 25 X 35 X 5
88	PSB1108088	KEY 6 X 6 X 15 RE
89	PSB1108089	COLLAR
90	PSB1108090	GASKET
91	PSB1108091	GEARBOX COVER
92	PSB1108092	CAP SCREW M6-1 X 25
93	PSB1108093	CAP SCREW M5-.8 X 12
94	PSB1108094	SPROCKET 12T
95	PSB1108095	PHLP HD SCR M4-.7X10
96	PSB1108096	PULLEY COVER
97	PSB1108097	PULLEY
98	PSB1108098	FENDER WASHER 5MM
99	PSB1108099	OIL PLUG NPT 1/4 X 3/4
100	PSB1108100	GEAR BOX



# SB1108 Main Parts List (Cont.)

REF	PART #	DESCRIPTION
101	PSB1108101	GEAR 18T
102	PSB1108102	KEY 4 X 4 X 16 RE
103	PSB1108103	GEARED SHAFT 18T/22T
104	PSB1108104	GEAR 71T
105	PSB1108105	GEARBOX GUARD
106	PSB1108106	FLAT WASHER 6MM
107	PSB1108107	TIMING BELT 3GT-741-15
108	PSB1108108	GEARBOX COVER
109	PSB1108109	EXT RETAINING RING 12MM
110	PSB1108110	ADJUSTING SHAFT
111	PSB1108111	LOCK ROD
112	PSB1108112	HEX NUT M12-1.75
113	PSB1108113	INFEEED ROLLER
114	PSB1108114	E-CLIP 15MM
115	PSB1108115	SPACER 20.5 X 32 X 6

REF	PART #	DESCRIPTION
116	PSB1108116	ANTI-KICKBACK FINGER
117	PSB1108117	SHAFT 19.95MM
118	PSB1108118	SPROCKET 31T
119	PSB1108119	CHAIN #06B X 67P
202	PSB1108202	BALL BEARING 6003ZZ
203	PSB1108203	OIL SEAL 12 X 22 X 7
204	PSB1108204	CAP SCREW M5-.8 X 6
205	PSB1108205	FLAT WASHER 5MM
207	PSB1108207	OUTER CHAIN TENSIONER
208	PSB1108208	STANDOFF-HEX MM 5/16-18 X 2-1/2, 3-5/16
212	PSB1108212	SET SCREW M6-1 X 16
220	PSB1108220	PHLP HD SCR M5-.8 X 8
221	PSB1108221	CORD ROUTING COVER
223	PSB1108223	CHIP BREAKER
224	PSB1108224	FOAM STRIP 8 X 10 X 390

# SB1108 Table & Base

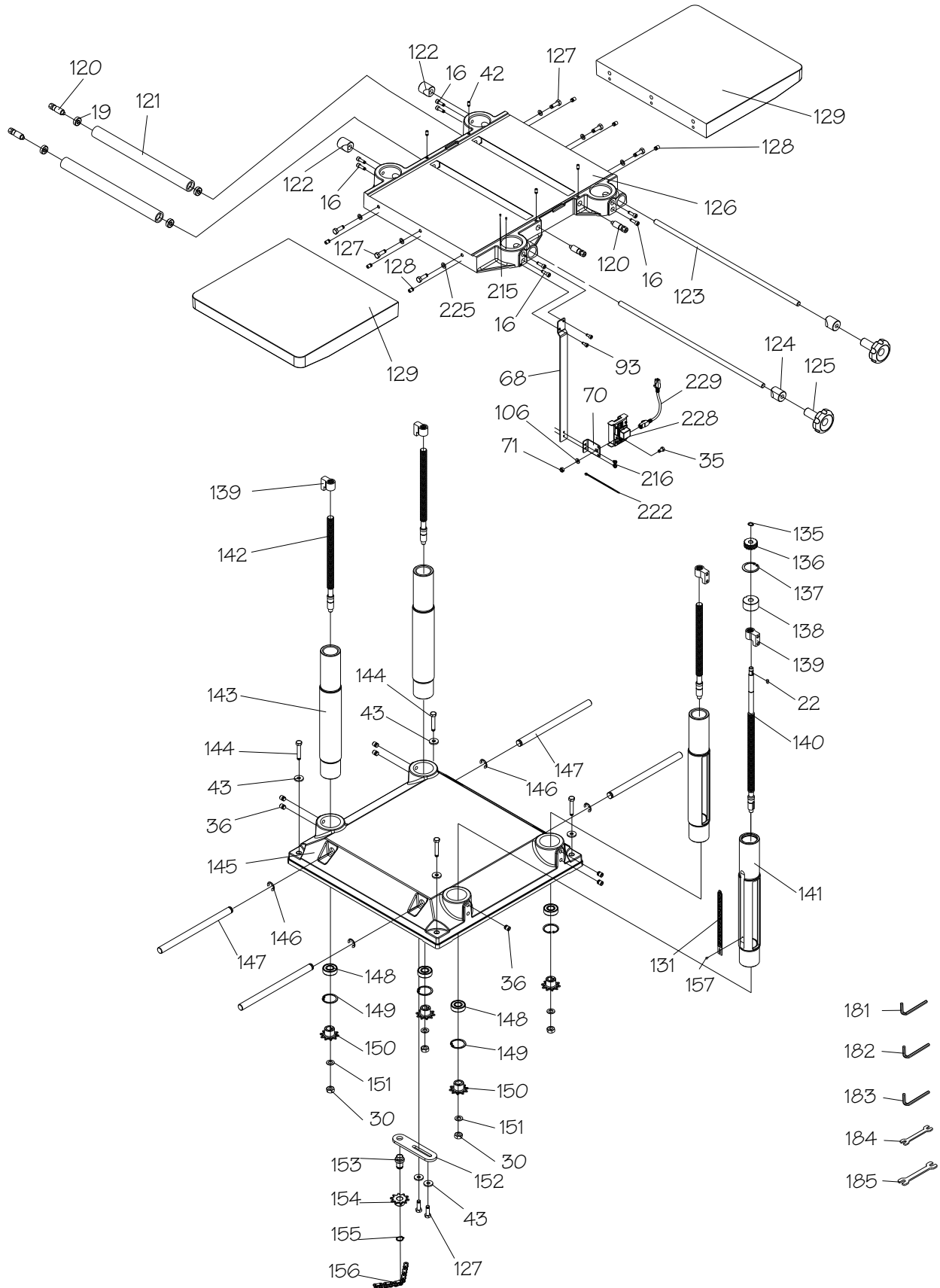

# SB1108 Table & Base Parts List

REF	PART #	DESCRIPTION
16	PSB1108016	CAP SCREW M6-1 X 20
19	PSB1108019	BALL BEARING 608Z
22	PSB1108022	KEY 4 X 4 X 10 RE
30	PSB1108030	HEX NUT M10-1.25
35	PSB1108035	HEX BOLT M6-1 X 12
36	PSB1108036	SET SCREW M10-1.5 X 12
42	PSB1108042	SET SCREW M6-1 X 12
43	PSB1108043	FENDER WASHER 8MM
68	PSB1108068	BRACKET
70	PSB1108070	PLATE
71	PSB1108071	HEX NUT M6-1
93	PSB1108093	CAP SCREW M5-.8 X 12
106	PSB1108106	FLAT WASHER 6MM
120	PSB1108120	ECCENTRIC SHAFT
121	PSB1108121	TABLE ROLLER
122	PSB1108122	THREADED GIB
123	PSB1108123	LOCKING ROD
124	PSB1108124	GIB
125	PSB1108125	KNOB LOBED M12-1.75
126	PSB1108126	MAIN TABLE
127	PSB1108127	HEX BOLT M8-1.25 X 25
128	PSB1108128	SET SCREW M8-1 X 12
129	PSB1108129	EXTENSION TABLE
131	PSB1108131	SCALE
135	PSB1108135	EXT RETAINING RING 10MM
136	PSB1108136	GEAR 14T
137	PSB1108137	INT RETAINING RING 38MM
138	PSB1108138	BUSHING
139	PSB1108139	LEADSCREW NUT 16-4

REF	PART #	DESCRIPTION
140	PSB1108140	LEADSCREW, PRIMARY
141	PSB1108141	COLUMN, PRIMARY
142	PSB1108142	LEADSCREW, SECONDARY
143	PSB1108143	COLUMN, SECONDARY
144	PSB1108144	HEX BOLT M8-1.25 X 45
145	PSB1108145	BASE
146	PSB1108146	E-CLIP 12MM
147	PSB1108147	LIFTING BAR
148	PSB1108148	BALL BEARING 6202Z
149	PSB1108149	INT RETAINING RING 35MM
150	PSB1108150	IDLER SPROCKET 10T
151	PSB1108151	FENDER WASHER 10MM
152	PSB1108152	BRACKET
153	PSB1108153	SHAFT
154	PSB1108154	SPROCKET 10T
155	PSB1108155	EXT RETAINING RING 15MM
156	PSB1108156	CHAIN #410 X 134P
157	PSB1108157	PHLP HD SCREW M3-.5 X 6
181	PSB1108181	HEX WRENCH 6MM
182	PSB1108182	HEX WRENCH 4MM
183	PSB1108183	HEX WRENCH 3MM
184	PSB1108184	WRENCH 10 X 13MM OPEN-ENDS
185	PSB1108185	WRENCH 12 X 14MM OPEN-ENDS
215	PSB1108215	RIVET 2 X 5
216	PSB1108216	PHLP HD SCR M5-.8 X 6
222	PSB1108222	CABLE TIE 4"
225	PSB1108225	FLAT WASHER 8MM
228	PSB1108228	DRO REMOTE SENSOR
229	PSB1108229	DRO CORD CAT5E 39"

# SB1108 Stand & Motor

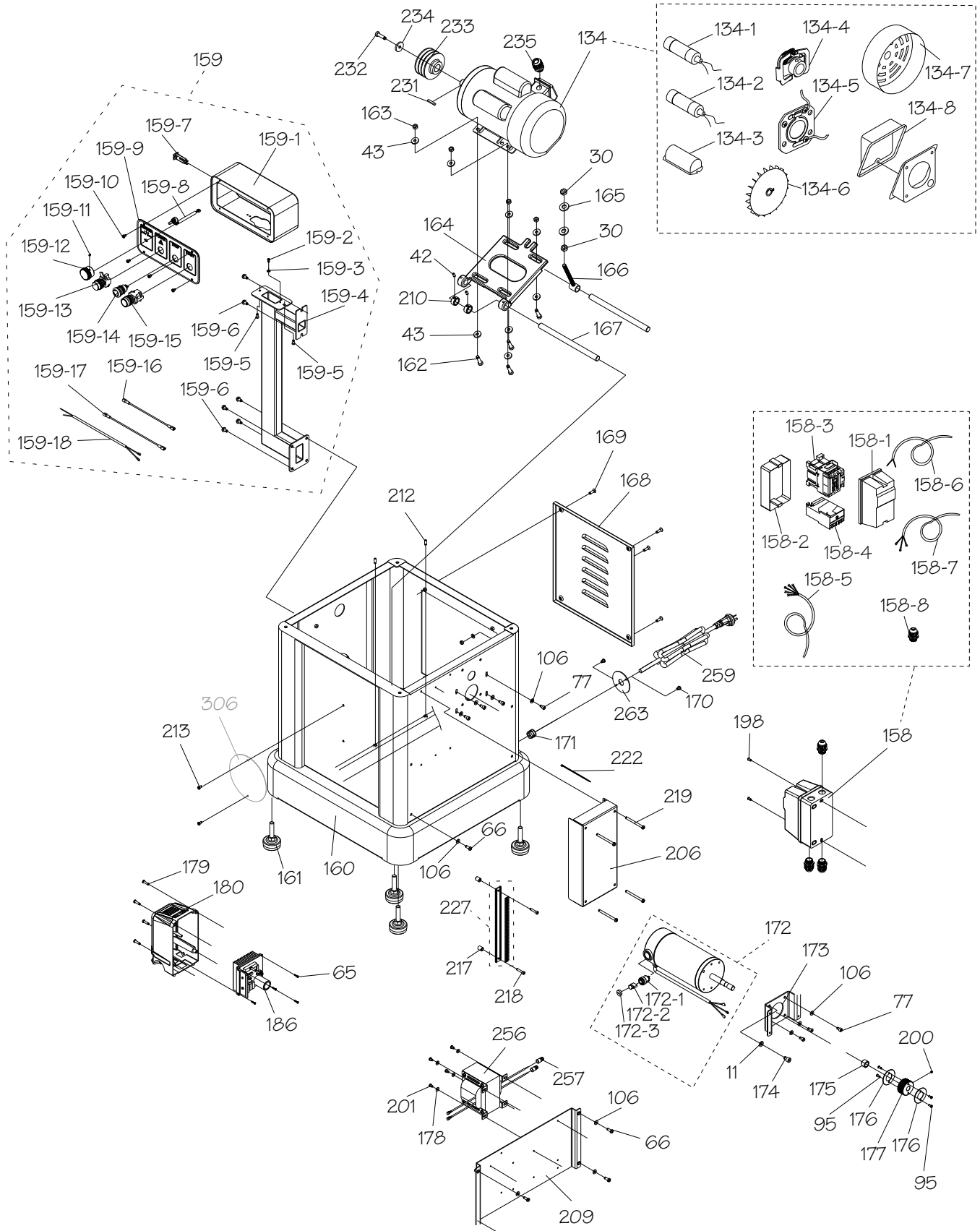



# SB1108 Stand & Motor Parts List

REF	PART #	DESCRIPTION
11	PSB1108011	FLAT WASHER 8MM
30	PSB1108030	HEX NUT M10-1.25
42	PSB1108042	SET SCREW M6-1 X 12
43	PSB1108043	FENDER WASHER 8MM
65	PSB1108065	TAP SCREW M3 X 8
66	PSB1108066	PHLP HD SCR M6-1 X 16
77	PSB1108077	CAP SCREW M6-1 X 12
95	PSB1108095	PHLP HD SCR M4-.7X10
106	PSB1108106	FLAT WASHER 6MM
134	PSB1108134	MOTOR 3HP 230V1-PH
134-1	PSB1108134-1	S CAPACITOR 400M 125V1-9/16 X 3-9/16
134-2	PSB1108134-2	R CAPACITOR 70M 250V1-9/16 X 3-9/16
134-3	PSB1108134-3	CAPACITOR COVER
134-4	PSB1108134-4	CENT SWITCH 16MM 3450
134-5	PSB1108134-5	CONTACT PLATE 16MM
134-6	PSB1108134-6	MOTOR FAN
134-7	PSB1108134-7	MOTOR FAN COVER
134-8	PSB1108134-8	MOTOR JUNCTION BOX
158	PSB1108158	MAGNETIC SWITCH SDE MPE-18
158-1	PSB1108158-1	MAG SWITCH COVER
158-2	PSB1108158-2	MAG SWITCH BASE
158-3	PSB1108158-3	CONTACTOR SDE MA-16 220V
158-4	PSB1108158-4	OL RELAY SDE RA-20 12-18A
158-5	PSB1108158-5	CONTROL PANEL CORD 18G 5W 86"
158-6	PSB1108158-6	TRANSFORMER CORD 18G 2W 23"
158-7	PSB1108158-7	MOTOR CORD 12G 3W 33"
158-8	PSB1108158-8	STRAIN RELIEF TYPE-3 PG13.5
159	PSB1108159	CONTROL PANEL ASSEMBLY
159-1	PSB1108159-1	CONTROL PANEL BOX
159-2	PSB1108159-2	PHLP HD SCR M4-.7X 6
159-3	PSB1108159-3	EXT TOOTH WASHER 4MM
159-4	PSB1108159-4	CONTROL PANEL PEDESTAL
159-5	PSB1108159-5	HEX BOLT M5-.8 X 10
159-6	PSB1108159-6	FLANGE BOLT M6-1 X 12
159-7	PSB1108159-7	CIRCUIT BREAKER SWITCH 10A ZE-800
159-8	PSB1108159-8	POTENTIOMETER 50K X 1900MM
159-9	PSB1108159-9	CONTROL PANEL FACE PLATE
159-10	PSB1108159-10	PHLP HD SCR M5-.8 X 8
159-11	PSB1108159-11	SET SCREW M4-.7X 6
159-12	PSB1108159-12	FEED SPEED ADJUSTMENT KNOB
159-13	PSB1108159-13	POWER INDICATOR LIGHT YUAN GUAN 25MM
159-14	PSB1108159-14	E-STOP BUTTON RENVY 250V, 22MM
159-15	PSB1108159-15	START SWITCH YUAN GUAN 250V, 22MM
159-16	PSB1108159-16	STOP BUTTON CORD 18G 1W 6"
159-17	PSB1108159-17	DC CONTROLLER CORD 18G 1W 8"
159-18	PSB1108159-18	CIRCUIT BREAKER CORD 18G 2W 71"
160	PSB1108160	CABINET STAND

REF	PART #	DESCRIPTION
161	PSB1108161	FOOT M12-1.75
162	PSB1108162	HEX BOLT M8-1.25 X 30
163	PSB1108163	HEX NUT M8-1.25
164	PSB1108164	MOTOR MOUNT PLATE
165	PSB1108165	FENDER WASHER 10MM
166	PSB1108166	MOTOR MOUNT CONNECTING ROD
167	PSB1108167	SHAFT
168	PSB1108168	MOTOR ACCESS PANEL
169	PSB1108169	PHLP HD SCR M6-1 X 20
170	PSB1108170	PHLP HD SCR M6-1 X 10
171	PSB1108171	STRAIN RELIEF TYPE-1 19MM
172	PSB1108172	DC MOTOR 3/4HP 90VDC 8A
172-1	PSB1108172-1	BRUSH BRACKET
172-2	PSB1108172-2	MOTOR BRUSH 120V (2-PC SET)
172-3	PSB1108172-3	BRUSH COVER
173	PSB1108173	MOTOR MOUNT PLATE
174	PSB1108174	CAP SCREW M8-1.25 X 12
175	PSB1108175	COLLAR
176	PSB1108176	PULLEY COVER
177	PSB1108177	PULLEY
178	PSB1108178	FLAT WASHER 5MM
179	PSB1108179	PHLP HD SCR M5-.8 X 20
180	PSB1108180	DC MOTOR CONTROL COVER
186	PSB1108186	DC MOTOR CONTROLLER AC 120V/DC
198	PSB1108198	PHLP HD SCR 3/16-24 X 3/8
200	PSB1108200	SET SCREW M5-.8 X 5
201	PSB1108201	PHLP HD SCR M5-.8 X 10
206	PSB1108206	DRO SENSOR COVER
209	PSB1108209	SWITCH PANEL
210	PSB1108210	SPACER 16.2 X 25 X 12.7
212	PSB1108212	SET SCREW M6-1 X 16
213	PSB1108213	PHLP HD SCR M5-.8 X 10
217	PSB1108217	SPACER 7 X 11.9 X 13.5
218	PSB1108218	CAP SCREW M5-.8 X 25
219	PSB1108219	PHLP HD SCR M6-1 X 70
222	PSB1108222	CABLE TIE 4"
227	PSB1108227	DRO SENSOR STRIP
231	PSB1108231	KEY 5 X 5 X 30 RE
232	PSB1108232	HEX BOLT M8-1.25 X 25
233	PSB1108233	MOTOR PULLEY
234	PSB1108234	FENDER WASHER 8MM
235	PSB1108235	STRAIN RELIEF TYPE-3 PG13.5
256	PSB1108256	TRANSFORMER SUEN 5PCL20660 220V
257	PSB1108257	WIRE NUT P3
259	PSB1108259	POWER CORD 12G 3W 138" 6-20P
263	PSB1108263	PLATE

# SB1108 Labels & Cosmetics

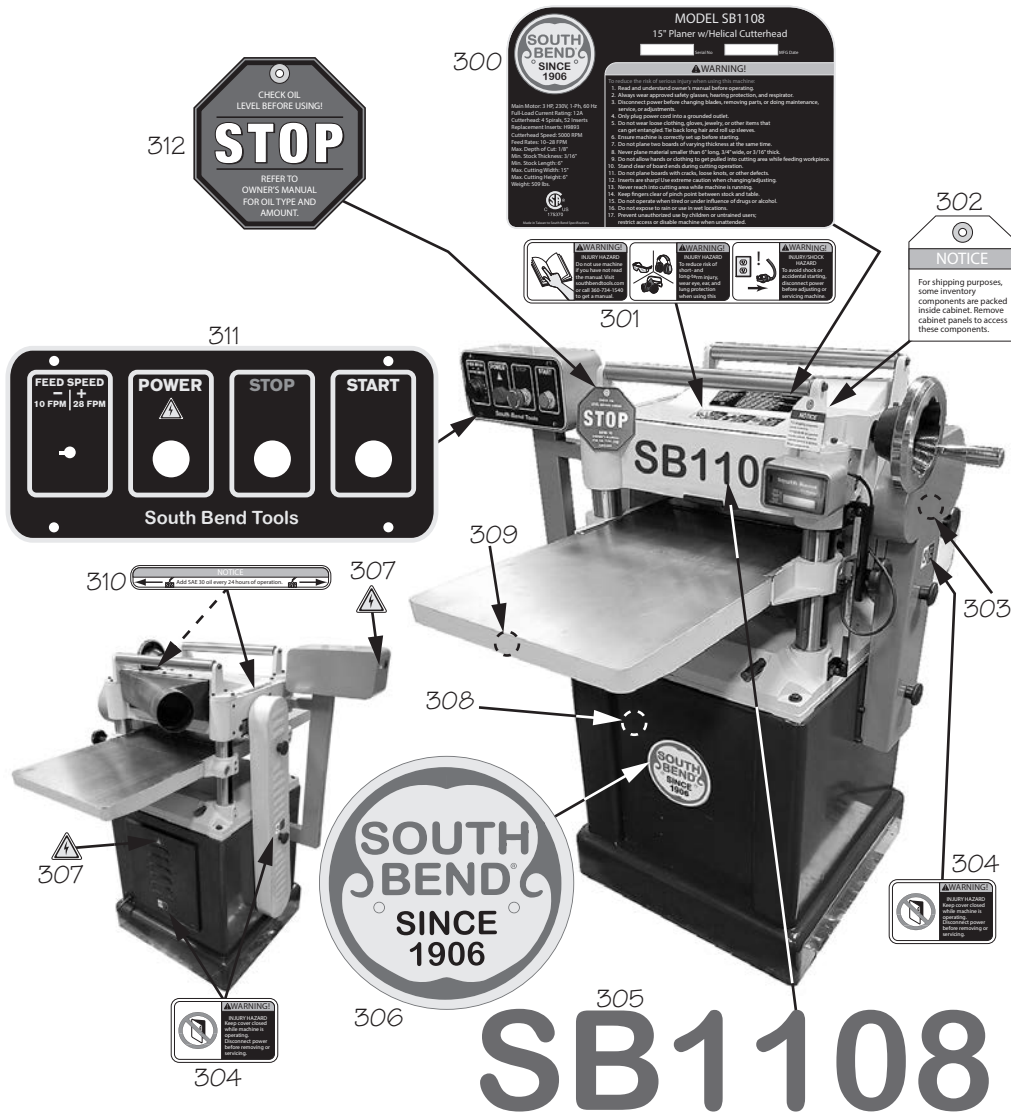

REF	PART #	DESCRIPTION
300	PSB1108300	MACHINE ID LABEL
301	PSB1108301	COMBO WARNING LABEL
302	PSB1108302	INVENTORY SHIPPING NOTICE
303	PSB1108303	TOUCH-UP PAINT, SB DARK BLUE
304	PSB1108304	DOOR CLOSED LABEL 2.5 X 1.5
305	PSB1108305	MODEL NUMBER LABEL
306	PSB1108306	SOUTH BEND NAMEPLATE 6"

REF	PART #	DESCRIPTION
307	PSB1108307	ELECTRICITY LABEL 0.7
308	PSB1108308	TOUCH-UP PAINT, SB LIGHT BLUE
309	PSB1108309	TOUCH-UP PAINT, SB GRAY
310	PSB1108310	ADD OIL NOTICE
311	PSB1108311	CONTROL PANEL LABEL
312	PSB1108312	STOP OIL FILL TAG

## ⚠️ WARNING

The safety labels provided with your machine are used to make the operator aware of the machine hazards and ways to prevent injury. The owner of this machine **MUST** maintain the original location and readability of these safety labels. If any label is removed or becomes unreadable, **REPLACE** that label before using the machine again. Contact South Bend Tools at (360) 734-1540 or [www.southbendtools.com](http://www.southbendtools.com) to order new labels.

# SB1109 Main

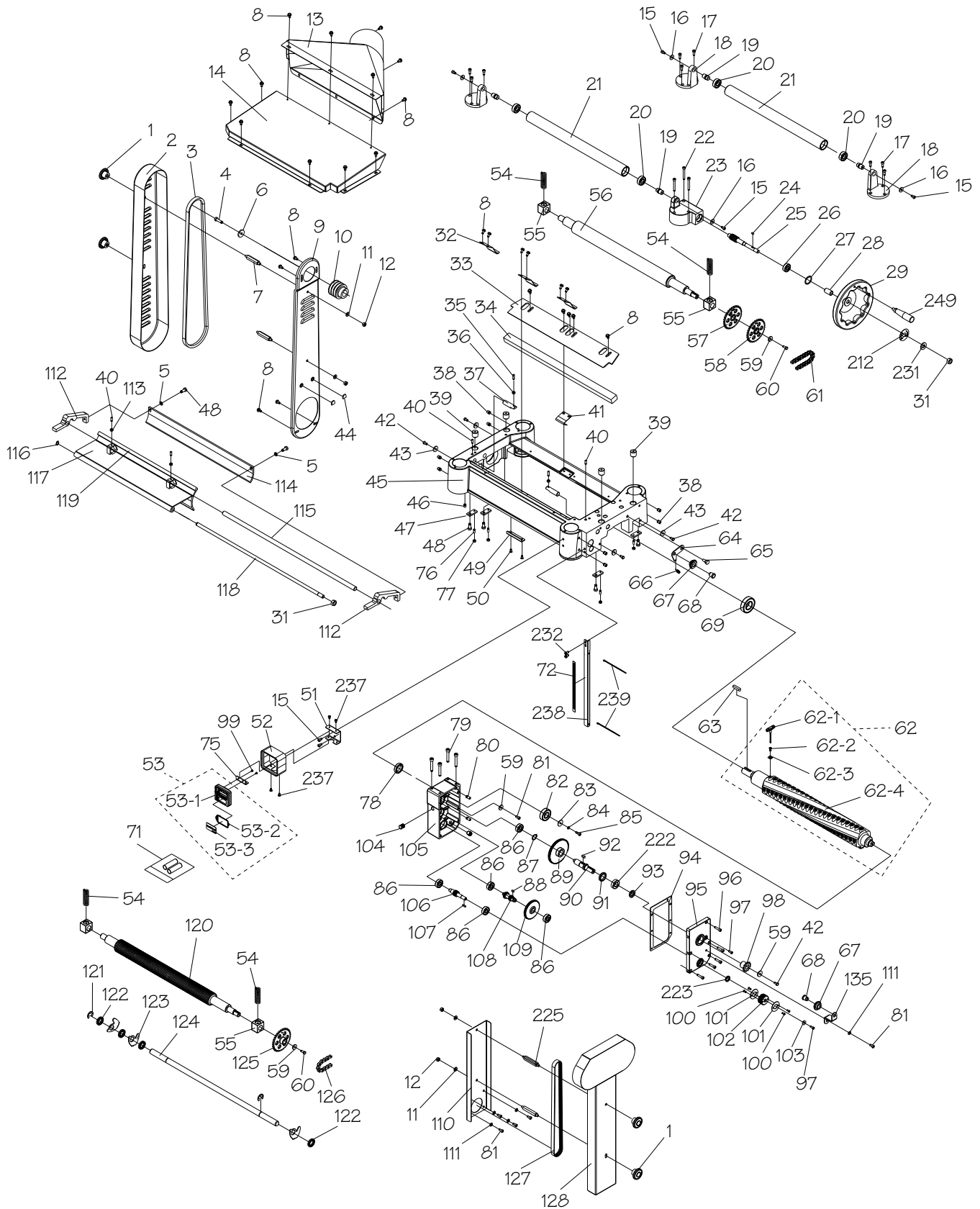

# SB1109 Main Parts List

REF	PART #	DESCRIPTION
1	PSB1109001	KNOB 5/16-18 LOBED
2	PSB1109002	BELT PULLEY COVER
3	PSB1109003	V-BELT M58
4	PSB1109004	HEX BOLT M8-1.25 X 30
5	PSB1109005	LOCK WASHER 8MM
6	PSB1109006	FENDER WASHER 8MM
7	PSB1109007	STANDOFF-HEX MM 5/16-18 X 2-1/4, 3/8
8	PSB1109008	FLANGE BOLT M6-1 X 12
9	PSB1109009	BELT PULLEY GUARD
10	PSB1109010	PULLEY
11	PSB1109011	FLAT WASHER 8MM
12	PSB1109012	HEX NUT 5/16-18
13	PSB1109013	DUST HOOD W/5" PORT
14	PSB1109014	UPPER COVER
15	PSB1109015	CAP SCREW M6-1 X 10
16	PSB1109016	FENDER WASHER 6MM
17	PSB1109017	CAP SCREW M6-1 X 16
18	PSB1109018	RETURN ROLLER BRACKET
19	PSB1109019	BEARING SHAFT
20	PSB1109020	BALL BEARING 6202-2NSE
21	PSB1109021	RETURN ROLLER
22	PSB1109022	CAP SCREW M6-1 X 50
23	PSB1109023	WORM GEAR HOUSING
24	PSB1109024	KEY 4 X 4 X 10 RE
25	PSB1109025	WORM SHAFT
26	PSB1109026	BALL BEARING 6201Z
27	PSB1109027	INT RETAINING RING 32MM
28	PSB1109028	COLLAR
29	PSB1109029	HANDWHEEL TYPE-14 200D12B-K 3/8-16
31	PSB1109031	HEX NUT M12-1.75
32	PSB1108032	SPRING PLATE
33	PSB1109033	CHIP DEFLECTOR
34	PSB1109034	FOAM GASKET
35	PSB1109035	SET SCREW M6-1 X 20
36	PSB1109036	HEX NUT M6-1
37	PSB1109037	SHAFT 5/8
38	PSB1109038	SET SCREW M10-1.5 X 12
39	PSB1109039	OILER SCREW M22-1.5 X 20
40	PSB1109040	SET SCREW M6-1 X 16
41	PSB1109041	SPRING PLATE
42	PSB1109042	HEX BOLT M6-1 X 12
43	PSB1109043	FENDER WASHER 6MM
44	PSB1109044	PLATE
45	PSB1109045	HEAD CASTING
46	PSB1109046	SET SCREW M8-1.25 X 12
47	PSB1109047	PLATE
48	PSB1109048	HEX BOLT M8-1.25 X 20
49	PSB1109049	DEPTH LIMITER
50	PSB1109050	FLAT HD SCR M5-.8 X 12
51	PSB1109051	DIGITAL READOUT BRACKET
52	PSB1109052	DIGITAL READOUT HOUSING

REF	PART #	DESCRIPTION
53	PSB1109053	DIGITAL READOUT ASSEMBLY
53-1	PSB1109053-1	DIGITAL READOUT WIXEY MODEL WR5502
53-2	PSB1109053-2	BATTERY COVER
53-3	PSB1109053-3	BATTERY COVER DECAL
54	PSB1109054	COMPRESSION SPRING 3.5 X 19.7 X 70
55	PSB1109055	COMPRESSION SPRING BUSHING BLOCK
56	PSB1109056	OUTFEED ROLLER
57	PSB1109057	SPROCKET 31T
58	PSB1109058	SPROCKET 31T
59	PSB1109059	FENDER WASHER 6MM
60	PSB1109060	HEX BOLT M6-1 X 16
61	PSB1109061	CHAIN #06B X 44P
62	PSB1109062	HELICAL CUTTERHEAD ASSY
62-1	PSB1109062-1	T-HANDLE TORX DRIVER T25
62-2	PSB1109062-2	FLAT HD TORX 10-32 X 1/2
62-3	PSB1109062-3	INSERT 15 X 15 X 2.5MM-10 PK
62-4	PSB1109062-4	HELICAL CUTTERHEAD 20"
63	PSB1109063	KEY 8 X 8 X 36 RE
64	PSB1109064	CHAIN TENSIONER
65	PSB1109065	SHOULDER BOLT M8-1.25 X 14.5, 4 X 12
66	PSB1109066	EXTENSION SPRING 1 X 8.5 X 35
67	PSB1109067	IDLER WHEEL
68	PSB1109068	IDLER SHAFT
69	PSB1109069	BALL BEARING 6206-2NSE
71	PSB1109071	BATTERY AAA (2 PCS)
72	PSB1109072	SCALE
75	PSB1109075	MOUNTING PLATE
76	PSB1109076	SET SCREW M10-1.5 X 30
77	PSB1109077	HEX NUT M10-1.5
78	PSB1109078	OIL SEAL 28 X 40 X 8
79	PSB1109079	CAP SCREW M8-1.25 X 50
80	PSB1109080	ROLL PIN 8 X 20
81	PSB1109081	CAP SCREW M6-1 X 12
82	PSB1109082	BALL BEARING 6204-2NSE
83	PSB1109083	FENDER WASHER 6MM
84	PSB1109084	LOCK WASHER 6MM
85	PSB1109085	CAP SCREW M6-1 X 16
86	PSB1109086	BALL BEARING 6201ZZ
87	PSB1109087	EXT RETAINING RING 20MM
88	PSB1109088	KEY 5 X 5 X 10 RE
89	PSB1109089	GEAR 96T
90	PSB1109090	SHAFT 24.5 X 105
91	PSB1109091	OIL SEAL 25 X 35 X 5
92	PSB1109092	KEY 6 X 6 X 15 RE
93	PSB1109093	COLLAR
94	PSB1109094	GASKET
95	PSB1109095	GEARBOX COVER
96	PSB1109096	CAP SCREW M6-1 X 25
97	PSB1109097	CAP SCREW M5-.8 X 12
98	PSB1109098	SPROCKET 12T
99	PSB1109099	TAP SCREW M3 X 8



# SB1109 Main Parts List (Cont.)

REF	PART #	DESCRIPTION
100	PSB1109100	PHLP HD SCR M4-.7X10
101	PSB1109101	PULLEY COVER
102	PSB1109102	PULLEY
103	PSB1109103	FENDER WASHER 5MM
104	PSB1109104	OIL PLUG NPT 1/4 X 3/4
105	PSB1109105	GEAR BOX
106	PSB1109106	GEAR 18T
107	PSB1109107	KEY 4 X 4 X 16 RE
108	PSB1109108	GEARED SHAFT 18T/22T
109	PSB1109109	GEAR 7T
110	PSB1109110	GEAR BOX GUARD
111	PSB1109111	FLAT WASHER 6MM
112	PSB1109112	CHIPBREAKER ADJUSTMENT BRACKET
113	PSB1109113	LOCK NUT M6-1
114	PSB1109114	PRESSURE BAR
115	PSB1109115	CHIPBREAKER ADJUSTMENT ROD
116	PSB1109116	EXT RETAINING RING 12MM
117	PSB1109117	CHIP BREAKER
118	PSB1109118	CHIP BREAKER PIVOT ROD
119	PSB1109119	GASKET 3/8 X 1/2 X 20-5/8
120	PSB1109120	INFEEED ROLLER

REF	PART #	DESCRIPTION
121	PSB1109121	E-CLIP 15MM
122	PSB1109122	SPACER 20.5 X 32 X 6
123	PSB1109123	ANTI-KICKBACK FINGER
124	PSB1109124	SHAFT 19.95MM
125	PSB1109125	SPROCKET 31T
126	PSB1109126	CHAIN #06B X 67P
127	PSB1109127	TIMING BELT 3GT-924-15
128	PSB1109128	GEAR BOX COVER
135	PSB1109135	OUTER CHAIN TENSIONER
212	PSB1109212	DIRECTION LABEL
222	PSB1109222	BALL BEARING 6003ZZ
223	PSB1109223	OIL SEAL 12 X 22 X 7
225	PSB1109225	STANDOFF-HEX MM 5/16-18 X 2-1/2, 3-5/16
231	PSB1109231	FENDER WASHER 12MM
232	PSB1109232	PHLP HD SCR M6-1 X 12
237	PSB1109237	PHLP HD SCR M5-.8 X 8
238	PSB1109238	CORD ROUTING COVER
239	PSB1109239	CABLE TIE 4"
241	PSB1109241	SET SCREW M6-1 X 16
249	PSB1109249	REVOLVING HANDLE 3/8-16 X 1/2

# SB1109 Table & Base

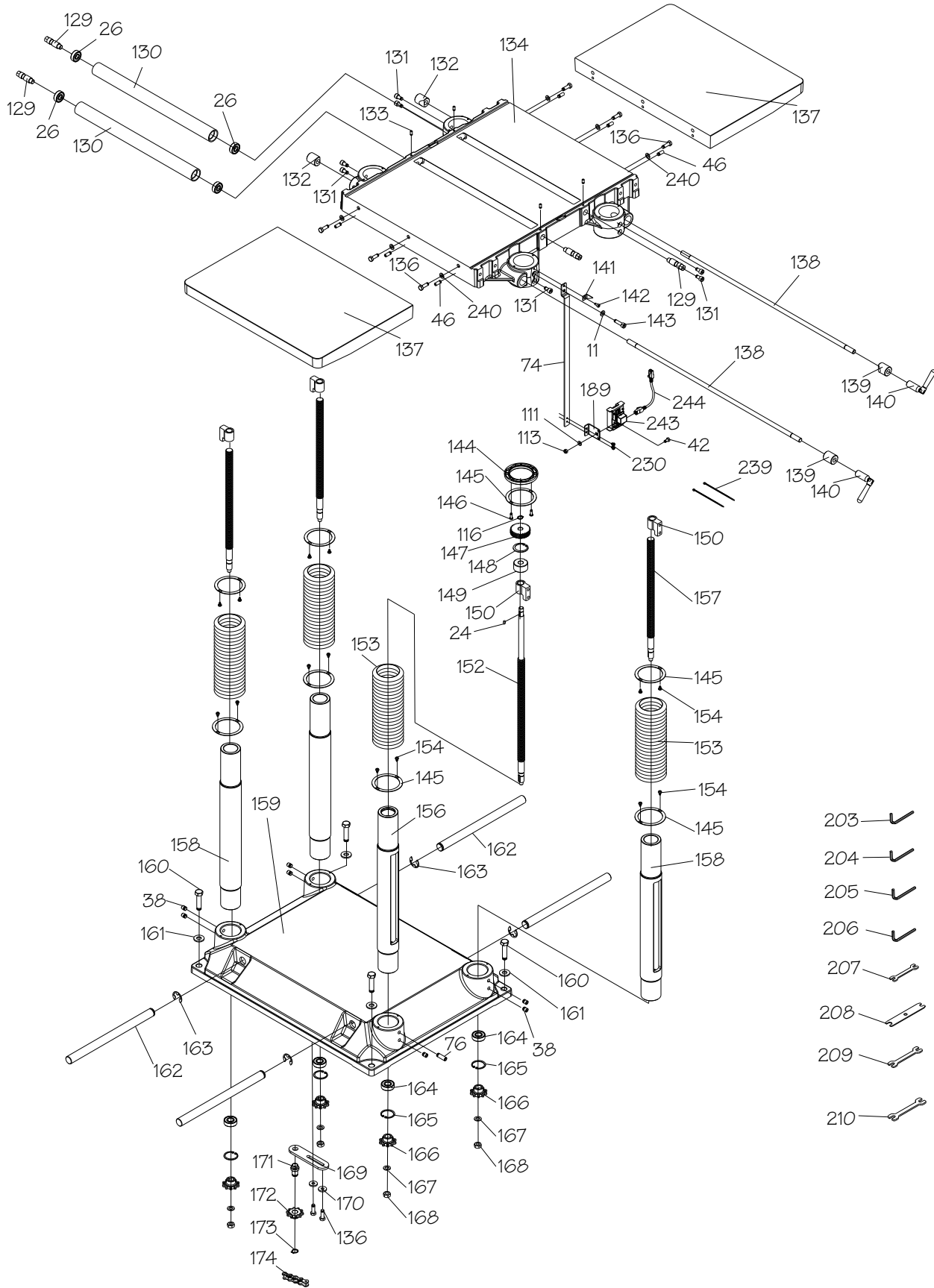

# SB1109 Table & Base Parts List

REF	PART #	DESCRIPTION
11	PSB1109011	FLAT WASHER 8MM
24	PSB1109024	KEY 4 X 4 X 10 RE
26	PSB1109026	BALL BEARING 6201Z
38	PSB1109038	SET SCREW M10-1.5 X 12
42	PSB1109042	HEX BOLT M6-1 X 12
46	PSB1109046	SET SCREW M8-1.25 X 12
74	PSB1109074	BRACKET
76	PSB1109076	SET SCREW M10-1.5 X 30
111	PSB1109111	FLAT WASHER 6MM
113	PSB1109113	LOCK NUT M6-1
116	PSB1109116	EXT RETAINING RING 12MM
129	PSB1109129	ECCENTRIC SHAFT
130	PSB1109130	TABLE ROLLER
131	PSB1109131	CAP SCREW M8-1.25 X 16
132	PSB1109132	THREADED GIB
133	PSB1109133	SET SCREW M6-1 X 12
134	PSB1109134	MAIN TABLE
136	PSB1109136	HEX BOLT M8-1.25 X 25
137	PSB1109137	EXTENSION TABLE
138	PSB1109138	LOCKING ROD
139	PSB1109139	THREADED GIB
140	PSB1109140	PIVOT HANDLE M12-1.75
141	PSB1109141	SCALE POINTER
142	PSB1109142	CAP SCREW M5-.8 X 10
143	PSB1109143	CAP SCREW M8-1.25 X 30
144	PSB1109144	PLATE
145	PSB1109145	COLLAR
146	PSB1109146	PHLP HD SCR M5-.8 X 15
147	PSB1109147	GEAR 24T
148	PSB1109148	INT RETAINING RING 38MM
149	PSB1109149	BUSHING
150	PSB1109150	LEADSCREW NUT 16-4
152	PSB1109152	LEADSCREW, PRIMARY
153	PSB1109153	DUST BOOT

REF	PART #	DESCRIPTION
154	PSB1109154	PHLP HD SCR M5-2.12 X 10
156	PSB1109156	COLUMN, PRIMARY
157	PSB1109157	LEADSCREW, SECONDARY
158	PSB1109158	COLUMN, SECONDARY
159	PSB1109159	BASE
160	PSB1109160	HEX BOLT M12-1.75 X 50
161	PSB1109161	FENDER WASHER 12MM
162	PSB1109162	LIFTING BAR
163	PSB1109163	E-CLIP 17MM
164	PSB1109164	BALL BEARING 6202Z
165	PSB1109165	INT RETAINING RING 35MM
166	PSB1109166	SPROCKET 10T
167	PSB1109167	FLAT WASHER 10MM
168	PSB1109168	HEX NUT M10-1.25
169	PSB1109169	BRACKET
170	PSB1109170	FENDER WASHER 8MM
171	PSB1109171	SHAFT
172	PSB1109172	SPROCKET 10T
173	PSB1109173	EXT RETAINING RING 15MM
174	PSB1109174	CHAIN #40 X 166P
189	PSB1109189	PLATE
203	PSB1109203	HEX WRENCH 3MM
204	PSB1109204	HEX WRENCH 4MM
205	PSB1109205	HEX WRENCH 5MM
206	PSB1109206	HEX WRENCH 6MM
207	PSB1109207	WRENCH 8 X 10MM OPEN-ENDS
208	PSB1109208	WRENCH 10 X 13MM OPEN-ENDS
209	PSB1109209	WRENCH 12 X 14MM OPEN-ENDS
210	PSB1109210	WRENCH 17 X 19MM OPEN-ENDS
230	PSB1109230	PHLP HD SCR M5-.8 X 6
239	PSB1109239	CABLE TIE 4"
240	PSB1109240	FLAT WASHER 8MM
243	PSB1109243	DRO REMOTE SENSOR
244	PSB1109244	DRO CORD CAT5E 39"

# SB1109 Stand & Motor

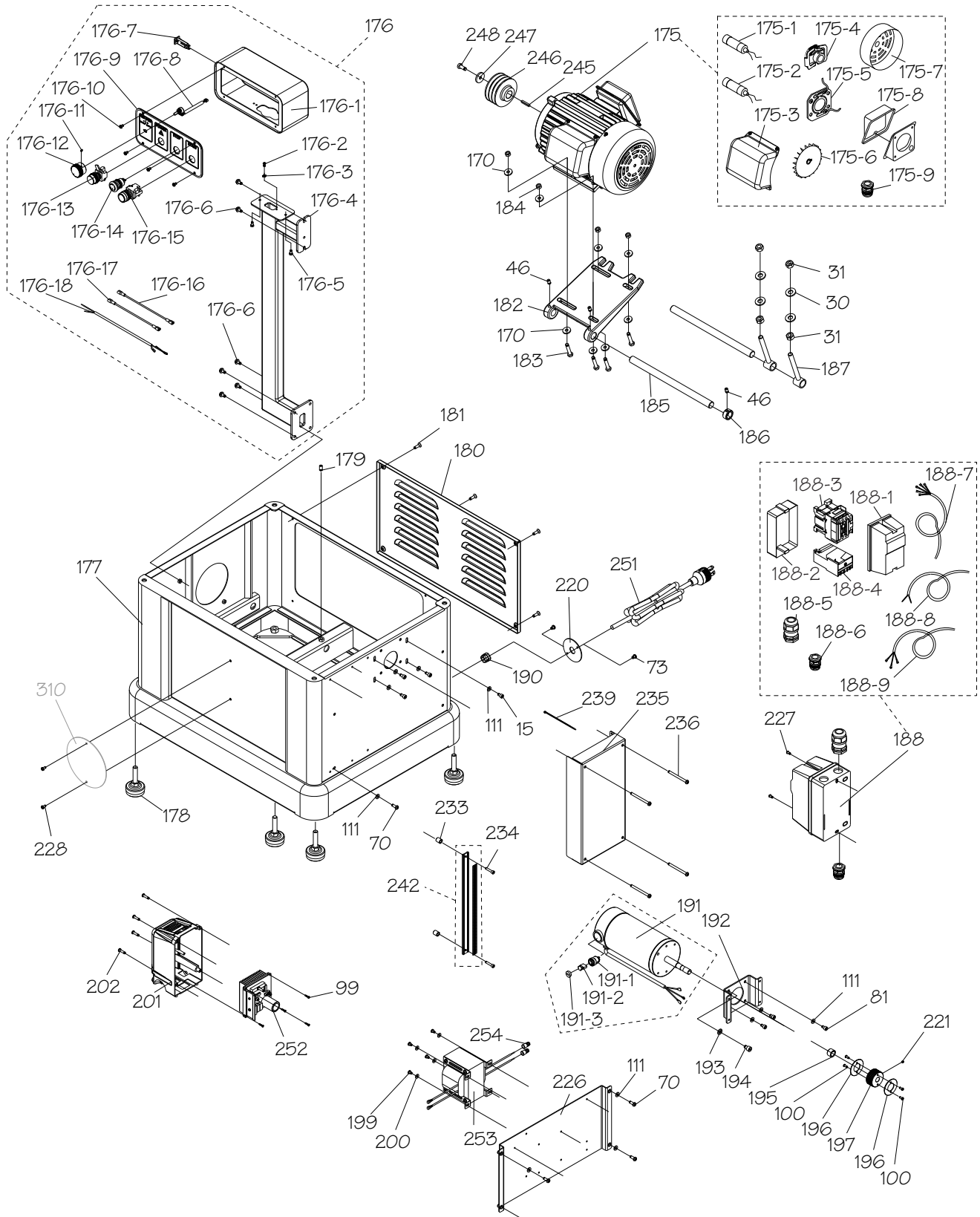

# SB1109 Stand & Motor Parts List

REF	PART #	DESCRIPTION
15	PSB1109015	CAP SCREW M6-1 X 10
30	PSB1109030	FENDER WASHER 12MM
31	PSB1109031	HEX NUT M12-1.75
46	PSB1109046	SET SCREW M8-1.25 X 12
70	PSB1109070	PHLP HD SCR M6-1 X 10
73	PSB1109073	PHLP HD SCR M6-1 X 8
81	PSB1109081	CAP SCREW M6-1 X 12
99	PSB1109099	TAP SCREW M3 X 8
100	PSB1109100	PHLP HD SCR M4-.7X10
111	PSB1109111	FLAT WASHER 6MM
170	PSB1109170	FENDER WASHER 8MM
175	PSB1109175	MOTOR 5HP 220-240V 1-PH
175-1	PSB1109175-1	S CAPACITOR 600M 125V 1-3/4 X 3-5/16
175-2	PSB1109175-2	R CAPACITOR 60M 350V 1-3/4 X 4-5/16
175-3	PSB1109175-3	CAPACITOR COVER
175-4	PSB1109175-4	CENT SWITCH 16MM 3450
175-5	PSB1109175-5	CONTACT PLATE
175-6	PSB1109175-6	MOTOR FAN
175-7	PSB1109175-7	FAN COVER
175-8	PSB1109175-8	MOTOR JUNCTION BOX
175-9	PSB1109175-9	STRAIN RELIEF SW-P4
176	PSB1109176	CONTROL PANEL ASSEMBLY
176-1	PSB1109176-1	CONTROL PANEL BOX
176-2	PSB1109176-2	PHLP HD SCR M4-.7X 6
176-3	PSB1109176-3	EXT TOOTH WASHER 4MM
176-4	PSB1109176-4	SWITCH PEDESTAL
176-5	PSB1109176-5	HEX BOLT M5-.8 X 10
176-6	PSB1109176-6	FLANGE BOLT M6-1 X 12
176-7	PSB1109176-7	CIRCUIT BREAKER SWITCH 10A ZE-800
176-8	PSB1109176-8	POTENTIOMETER 50K W/86" CORD
176-9	PSB1109176-9	CONTROL PANEL FACE PLATE
176-10	PSB1109176-10	PHLP HD SCR M5-.8 X 8
176-11	PSB1109176-11	SET SCREW M4-.7X 6
176-12	PSB1109176-12	FEED SPEED ADJUSTMENT KNOB
176-13	PSB1109176-13	POWER INDICATOR LIGHT 25MM 250V 1.2W
176-14	PSB1109176-14	E-STOP BUTTON RENVY 250V, 22MM
176-15	PSB1109176-15	START SWITCH 250V, 22MM
176-16	PSB1109176-16	DC MOTOR CONTROL CORD 18G 1W 8"
176-17	PSB1109176-17	STOP BUTTON CORD 18G 1W 6"
176-18	PSB1109176-18	CIRCUIT BREAKER CORD 18G 2W 71"
177	PSB1109177	CABINET STAND
178	PSB1109178	FOOT M12-1.75
179	PSB1109179	SET SCREW M8-1.25 X 40
180	PSB1109180	MOTOR ACCESS COVER
181	PSB1109181	FLAT HD SCR M6-1 X 20
182	PSB1109182	MOTOR MOUNT PLATE
183	PSB1109183	HEX BOLT M8-1.25 X 40
184	PSB1109184	HEX NUT M8-1.25

REF	PART #	DESCRIPTION
185	PSB1109185	SHAFT
186	PSB1109186	COLLAR
187	PSB1109187	MOTOR MOUNT CONNECTING ROD
188	PSB1109188	MAG SWITCH 5H SDE
188-1	PSB1109188-1	MAG SWITCH COVER
188-2	PSB1109188-2	MAG SWITCH BASE
188-3	PSB1109188-3	CONTACTOR SDE MA-30 220V-240V
188-4	PSB1109188-4	OL RELAY SDE RA-30 22-34A
188-5	PSB1109188-5	STRAIN RELIEF TYPE-3 M25-1.5
188-6	PSB1109188-6	STRAIN RELIEF TYPE-3 M25-1.5
188-7	PSB1109188-7	CONTROL PANEL CORD 18G 5W 98"
188-8	PSB1109188-8	TRANSFORMER CORD 18G 2W 23"
188-9	PSB1109188-9	MOTOR CORD 12G 3W X 37"
190	PSB1109190	STRAIN RELIEF TYPE-1 19MM
191	PSB1109191	DC MOTOR 3/4HP 90VDC 8A
191-1	PSB1109191-1	BRUSH BRACKET
191-2	PSB1109191-2	MOTOR BRUSH 120V (2PC SET)
191-3	PSB1109191-3	BRUSH COVER
192	PSB1109192	MOTOR MOUNT PLATE
193	PSB1109193	FLAT WASHER 8MM
194	PSB1109194	CAP SCREW M8-1.25 X 12
195	PSB1109195	COLLAR
196	PSB1109196	PULLEY COVER
197	PSB1109197	PULLEY
199	PSB1109199	PHLP HD SCR M5-.8 X 10
200	PSB1109200	FLAT WASHER 5MM
201	PSB1109201	DC MOTOR CONTROL COVER
202	PSB1109202	PHLP HD SCR M5-.8 X 20
220	PSB1109220	PLATE
221	PSB1109221	SET SCREW M5-.8 X 20
226	PSB1109226	SWITCH PANEL
227	PSB1109227	PHLP HD SCR 3/16-24 X 3/8
228	PSB1109228	PHLP HD SCR M5-.8 X 10
233	PSB1109233	SPACER 7X 11.9 X 13.5
234	PSB1109234	CAP SCREW M5-.8 X 25
235	PSB1109235	DRO SENSOR COVER
236	PSB1109236	PHLP HD SCR M6-1 X 70
239	PSB1109239	CABLE TIE 4"
242	PSB1109242	DRO SENSOR STRIP
245	PSB1109245	KEY 5 X 5 X 30 RE
246	PSB1109246	MOTOR PULLEY
247	PSB1109247	FENDER WASHER 8MM
248	PSB1109248	HEX BOLT M8-1.25 X 20
251	PSB1109251	POWER CORD 12G 3W 145" L6-30P
252	PSB1109252	DC MOTOR CONTROLLER
253	PSB1109253	TRANSFORMER SP-CL-20660 220V
254	PSB1109254	WIRE NUT P3



# SB1109 Labels & Cosmetics



REF	PART #	DESCRIPTION
300	PSB1109300	MODEL NUMBER LABEL
301	PSB1109301	DOOR CLOSED LABEL 2.5 X 1.5
302	PSB1109302	STOP OIL FILL TAG
303	PSB1109303	TOUCH-UP PAINT, SB DARK BLUE
304	PSB1109304	ELECTRICITY LABEL 0.7
305	PSB1109305	ADD OIL NOTICE
306	PSB1109306	COMBO WARNING LABEL

REF	PART #	DESCRIPTION
307	PSB1109307	TOUCH-UP PAINT, SB GRAY
308	PSB1109308	TOUCH-UP PAINT, SB LIGHT BLUE
309	PSB1109309	MACHINE ID LABEL
310	PSB1109310	SOUTH BEND NAMEPLATE 6"
311	PSB1109311	CONTROL PANEL LABEL
312	PSB1109312	INVENTORY SHIPPING NOTICE

## ⚠️ WARNING

The safety labels provided with your machine are used to make the operator aware of the machine hazards and ways to prevent injury. The owner of this machine **MUST** maintain the original location and readability of these safety labels. If any label is removed or becomes unreadable, **REPLACE** that label before using the machine again. Contact South Bend Tools at (360) 734-1540 or [www.southbendtools.com](http://www.southbendtools.com) to order new labels.

# Warranty

This quality product is warranted by South Bend Tools to the original buyer for **2 years** from the date of purchase. This warranty does not apply to consumable parts, or defects due to any kind of misuse, abuse, negligence, accidents, repairs, alterations or lack of maintenance. We do not reimburse for third party repairs. In no event shall we be liable for death, injuries to persons or property, or for incidental, contingent, special or consequential damages arising from the use of our products.

We do not warrant or represent that this machine complies with the provisions of any law, act, code, regulation, or standard of any domestic or foreign government, industry, or authority. In no event shall South Bend's liability under this warranty exceed the original purchase price paid for this machine. Any legal actions brought against South Bend Tools shall be tried in the State of Washington, County of Whatcom.

This is the sole written warranty for this machine. Any and all warranties that may be implied by law, including any merchantability or fitness, for any purpose, are hereby limited to the duration of this warranty.

Thank you for your business and continued support.

To take advantage of this warranty, register at <https://www.grizzly.com/forms/warranty>, or you can scan the QR code below to be automatically directed to our warranty registration page. Enter all applicable information for the product.





[southbendtools.com](http://southbendtools.com)



Printed In Taiwan

#JPCS21259