


# READ THIS FIRST

	<p><b>MODEL SB1100/SB1101</b>  <b>***IMPORTANT UPDATE***</b>  <b>Applies to Models Mfd. Since 01/22</b>  <b>and Owner's Manual Revised 05/21</b></p>	
---	--	---

The following change was made to this machine since the owner's manual was printed:

- The inlet adapter has changed.

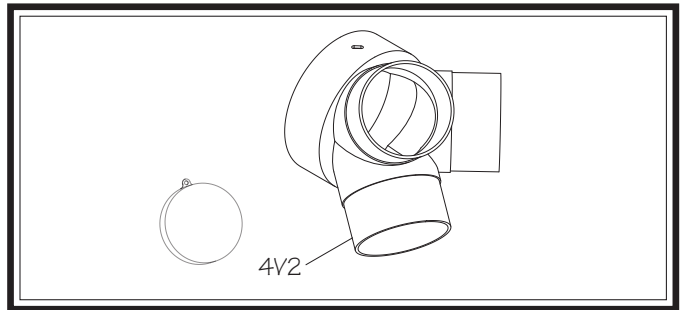
Aside from this information, all other content in the owner's manual applies and **MUST** be read and understood for your own safety. **IMPORTANT: Keep this update with the owner's manual for future reference.**

*If you have any further questions about this manual update or the changes made to the machine, contact our Technical Support at (360) 734-1540 or email [www.southbendtools.com](http://www.southbendtools.com).*

## Old Inlet Adapter



## SB1100 Revised Parts

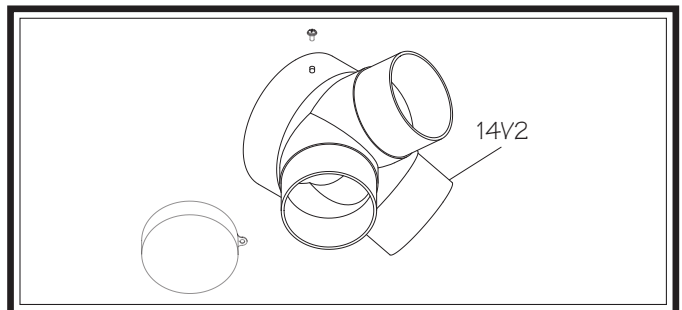


REF	PART #	DESCRIPTION
4V2	PSB1100004V2	INLET ADAPTER 6" X 4" X 3 (PC) V2.01.22

## New Inlet Adapter



## SB1101 Revised Parts

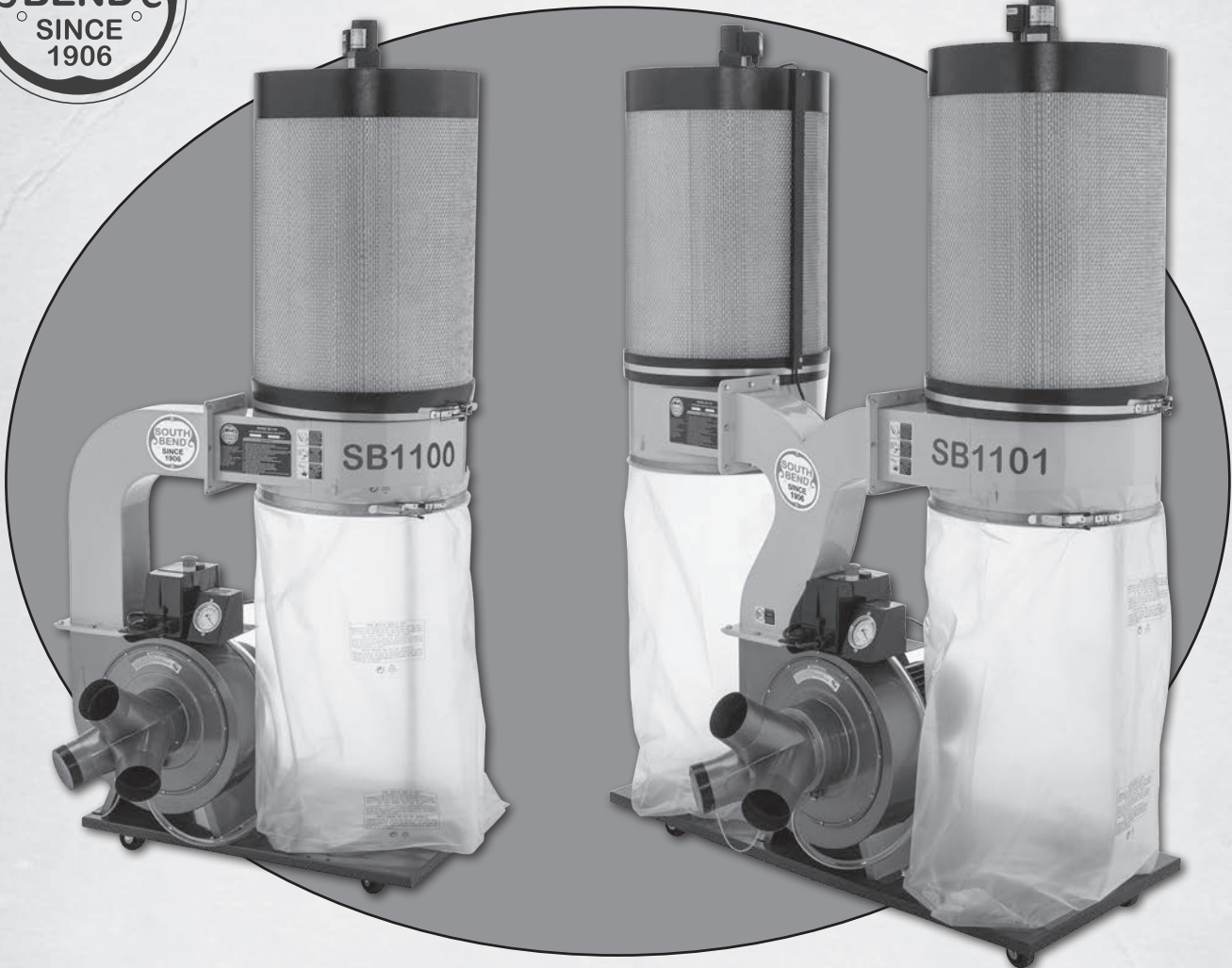


REF	PART #	DESCRIPTION
14V2	PSB1101014V2	INLET ADAPTER 7" X 4" X 3 (PC) V2.01.22

Copyright © September, 2022 by South Bend Tools  
**WARNING: No portion of this manual may be reproduced without written approval.**  
**#JM22435 Printed in Taiwan**

# SINGLE-STAGE DUST COLLECTORS

MODELS SB1100 & SB1101



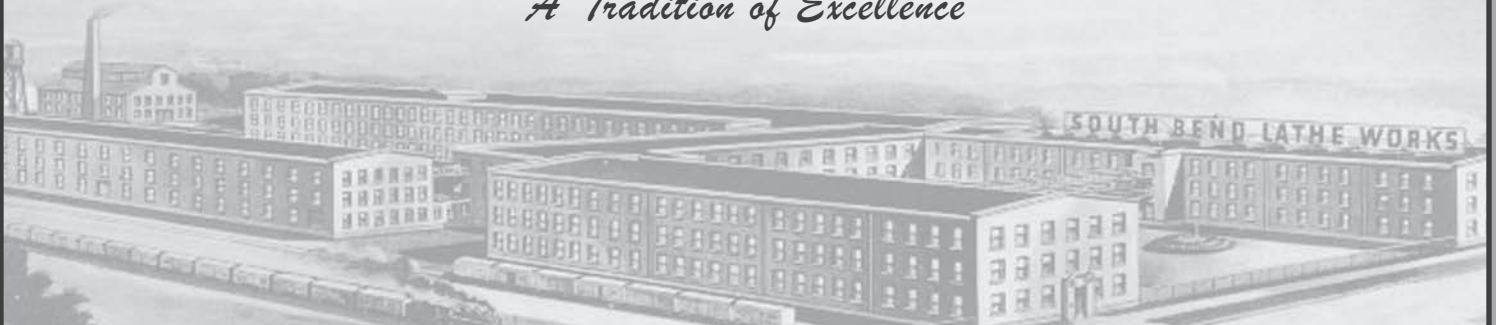
**OWNER'S MANUAL**

---

# South Bend Tools®

---

*A Tradition of Excellence*



# Scope of Manual

This manual helps the reader understand the machine, how to prepare it for operation, how to control it during operation, and how to keep it in good working condition. We assume the reader has a basic understanding of how to operate this type of machine, but that the reader is not familiar with the controls and adjustments of this specific model. As with all machinery of this nature, learning the nuances of operation is a process that happens through training and experience. If you are not an experienced operator of this type of machinery, read through this entire manual, then learn more from an experienced operator, schooling, or research before attempting operations. Following this advice will help you avoid serious personal injury and get the best results from your work.

# Manual Feedback

We've made every effort to be accurate when documenting this machine. However, errors sometimes happen or the machine design changes after the documentation process—so the manual may not exactly match your machine. If a difference between the manual and machine leaves you in doubt, contact our customer service for clarification.

We highly value customer feedback on our manuals. If you have a moment, please share your experience using this manual. What did you like about it? Is there anything you would change to make it better? Did it meet your expectations for clarity, professionalism, and ease-of-use?

**South Bend Tools**  
**c/o Technical Documentation Manager**  
**P.O. Box 2027**  
**Bellingham, WA 98227**  
**Email: [manuals@southbendtools.com](mailto:manuals@southbendtools.com)**

# Updates

For your convenience, any updates to this manual will be available to download free of charge through our website at:

**[www.southbendtools.com](http://www.southbendtools.com)**

# Customer Service

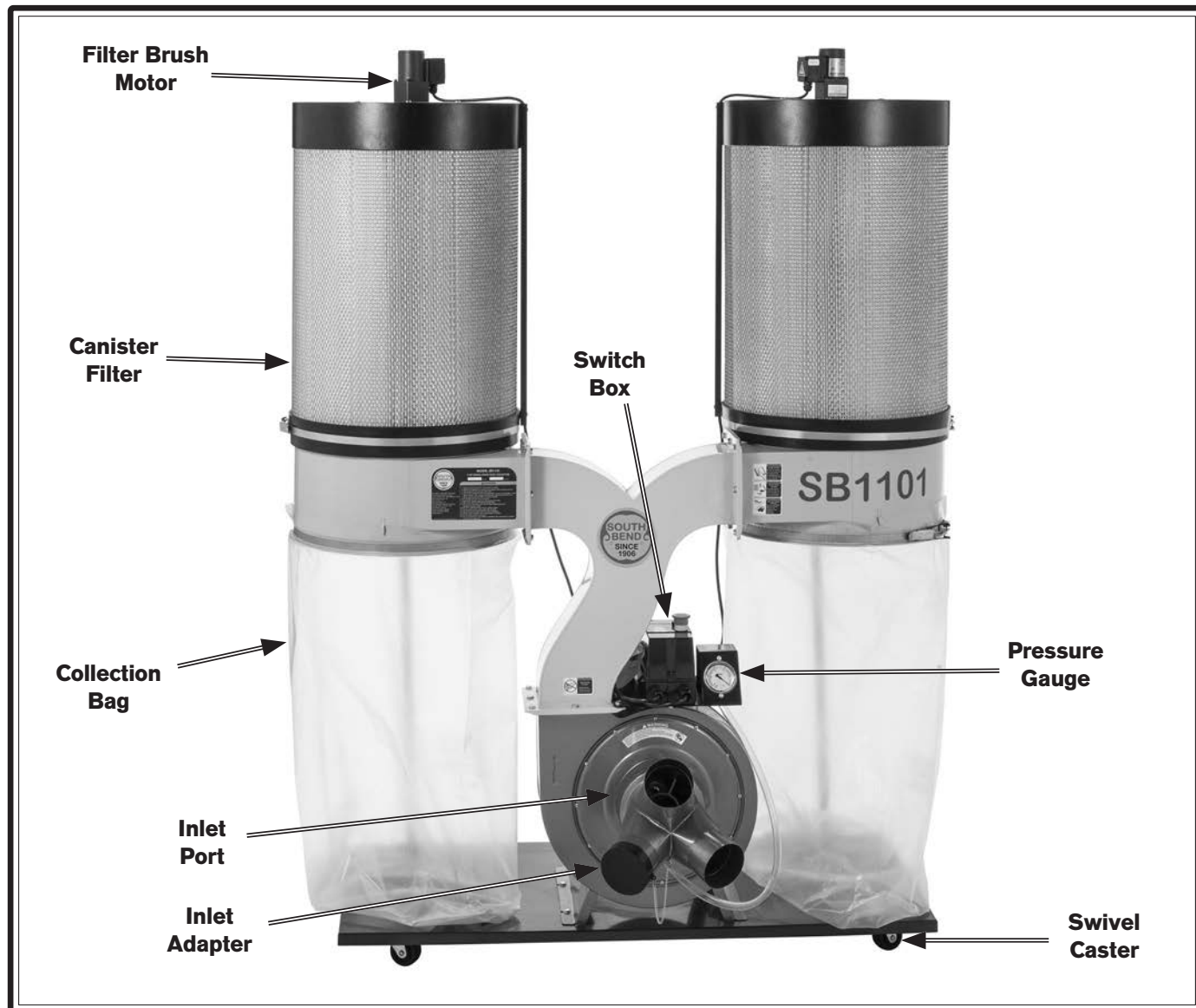
We stand behind our machines. If you have any service questions, parts requests or general questions about your purchase, feel free to contact us.

**South Bend Tools**  
**P.O. Box 2027**  
**Bellingham, WA 98227**  
**Phone: (360) 734-1540**  
**Fax: (360) 676-1075 (International)**  
**Fax: (360) 734-1639 (USA Only)**  
**Email: [sales@southbendtools.com](mailto:sales@southbendtools.com)**

# Table of Contents

<b>INTRODUCTION</b> .....	<b>2</b>	<b>OPERATION</b> .....	<b>32</b>
Identification .....	2	Operation Overview.....	32
Description of Controls & Components .....	3	<b>ACCESSORIES</b> .....	<b>33</b>
Product Specifications .....	4	<b>MAINTENANCE</b> .....	<b>36</b>
<b>SAFETY</b> .....	<b>7</b>	Maintenance Schedule.....	36
Understanding Risks of Machinery .....	7	Cleaning Canister Filter.....	36
Basic Machine Safety .....	7	Removing/Replacing Collection Bag .....	37
Additional Dust Collector Safety .....	9	Removing/Replacing Canister Filter .....	37
<b>PREPARATION</b> .....	<b>10</b>	<b>SERVICE</b> .....	<b>41</b>
Preparation Overview.....	10	Pairing Remote Control & Receiver.....	41
Required for Setup.....	10	<b>TROUBLESHOOTING</b> .....	<b>42</b>
Power Supply Requirements .....	11	<b>ELECTRICAL</b> .....	<b>44</b>
Unpacking .....	13	Electrical Safety Instructions .....	44
SB1100 Inventory .....	13	SB1100 Wiring Diagram .....	45
SB1101 Inventory .....	14	SB1100 Electrical Component Pictures.....	46
Hardware Recognition Chart .....	15	SB1101 Wiring Diagram .....	48
Location .....	16	SB1101 Electrical Component Pictures.....	49
Assembly .....	17	<b>PARTS</b> .....	<b>51</b>
Test Run .....	22	SB1100 Main.....	51
<b>SYSTEM DESIGN</b> .....	<b>23</b>	SB1101 Main.....	53
General .....	23	Canister Filter.....	55
Duct Material.....	23	Machine Labels .....	56
System Design.....	25	<b>WARRANTY</b> .....	<b>57</b>
System Grounding .....	31		

# Identification



## **!WARNING**

Serious personal injury could occur if you connect the machine to power before completing the setup process. **DO NOT** connect power until instructed to do so later in this manual.

## **!WARNING**

Untrained users have an increased risk of seriously injuring themselves with this machine. Do not operate this machine until you have understood this entire manual and received proper training.



## Description of Controls & Components

Refer to **Figures 1-2** and the following descriptions to become familiar with the basic controls and components used to operate this machine.

- A. Switch Box:** Controls motor operation with a thermally protected magnetic switch. Houses an RF receiver for remote control operation.
- B. Start Button:** Turns machine **ON**.
- C. Emergency Stop Button:** Turns machine **OFF** and prevents it from starting. Turn button clockwise to reset.
- D. Filter Brush Motor:** Turns **ON** for approximately 90 seconds after main motor is turned **OFF**. Knocks dust cake off filter pleats, cleaning filter and maintaining air flow. Filter brush motor run time can be changed at timer inside switch box (refer to **Wiring on Page 44**).
- E. Pressure Gauge:** Displays vacuum pressure, indicating when filter and collection bags need to be cleaned or replaced. Clean filter when operating pressure drops below 200mmAq. If operating pressure reaches 150mmAq and cleaning does not improve performance, replace the filter.
- F. Collection Bag:** Collects fine dust particles from filter.
- G. Remote Control:** Green button turns motor **ON**. Red button turns motor **OFF**. Requires a 12V, type A27 battery.

**Note:** *The remote control operates on radio frequency and has a 75-ft. range. It does not need to be aimed at the switch box to operate.*

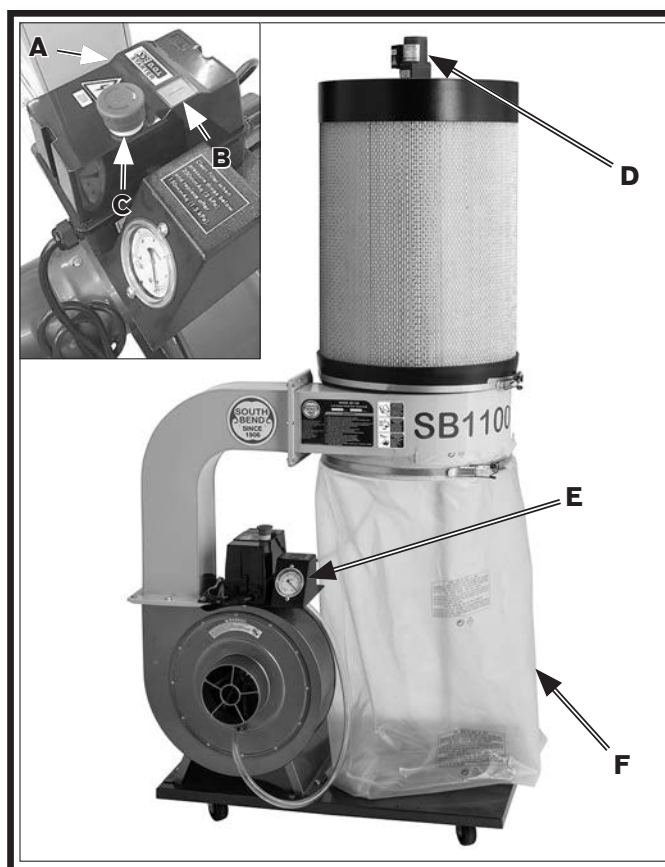


Figure 1. SB1100 & SB1101 components.

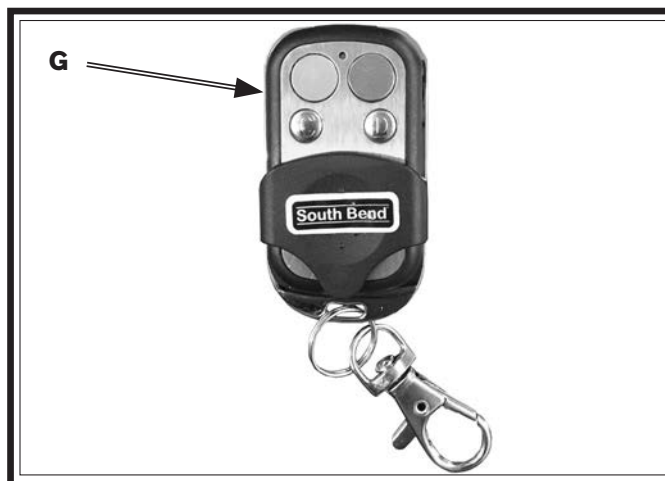


Figure 2. SB1100 & SB1101 remote control.



## Model SB1100 & SB1101 Cyclone Dust Collectors

Model Number	SB1100	SB1101
<b>Product Dimensions</b>		
Weight	157 lbs	208 lbs.
Width x Depth x Height	39 x 31-1/2 x 76 in.	58 x 31-1/2 x 76 in.
Footprint (Length/Width)	33-1/2 x 21-1/2 in.	49-1/2 x 21-1/2 in.
<b>Shipping Dimensions</b>		
Carton #1 Type	Cardboard Box	
Weight	131 lbs.	169 lbs.
Length x Width x Height	23 x 36 x 23 in.	52 x 23 x 23 in.
Carton #2 Type	Cardboard Box (Canister Filter)	
Weight	34 lbs	
Length x Width x Height	22 x 22 x 32 in.	
Carton #3 Type	N/A	Cardboard Box (Canister Filter 2)
Weight	N/A	34 lbs
Length x Width x Height	N/A	22 x 22 x 32 in.
<b>Operation</b>		
Dust Collector Type	Single-Stage	
Approved Dust Types	Wood	
Filter Type	Pleated Cartridge	
Airflow Performance	1103 CFM @ 3.5 in. SP	1429 CFM @ 3.2 in. SP
Max Static Pressure (at 0 CFM)	11.95 in.	12 in.
Main Inlet Size	6 in.	7 in.
Number of Adapter Inlets	3	3
Adapter Inlet Size	4 in.	4 in.
Machine Collection Capacity at One Time	3	3
Maximum Material Collection Capacity	33-1/2 Gallons	67 Gallons
Filtration Rating	1 Micron	1 Micron
Filter Surface Area	80 sq. ft.	160 sq. ft.

<b>Model Number</b>	<b>SB1100</b>	<b>SB1101</b>
<b>Electrical</b>		
Power Requirement	220V, Single-Phase, 60 Hz	240V, Single-Phase, 60 Hz
Full-Load Current Rating	9A	12A
Minimum Circuit Size	15A	20A
Connection Type	Cord & Plug	
Power Cord Included	Yes	Yes
Power Cord Length	65 in.	64 in.
Power Cord Gauge	14 AWG	
Plug Included	Yes	
Included Plug Type	6-15	6-20
Switch Type	Remote Control Magnetic Switch w/Overload Protection	
<b>Main Motor</b>		
Type	TEFC Capacitor-Start Induction	
Horsepower	2 HP	3 HP
Phase	Single-Phase	
Amps	9A	12A
Speed	3450 RPM	
Power Transfer	Direct	
Bearings	Shielded & Permanently Lubricated	
Centrifugal Switch/Contacts Type	External	
<b>Filter Brush Motor</b>		
Type	TENV Induction	
Horsepower	6W	
Phase	Single-Phase	
Amps	0.15A	
Speed	1600 RPM	
Power Transfer	Direct	
Bearings	Shielded & Permanently Lubricated	
Centrifugal Switch/Contacts Type	External	
<b>Filter Brush Motor 2</b>		
Type	N/A	TENV Induction
Horsepower	N/A	6W
Phase	N/A	Single-Phase
Amps	N/A	0.15A
Speed	N/A	1600 RPM
Power Transfer	N/A	Direct
Bearings	N/A	Shielded & Permanently Lubricated
Centrifugal Switch/Contacts Type	N/A	External



<b>Model Number</b>	<b>SB1100</b>	<b>SB1101</b>
<b>Bag Information</b>		
Number of Filter Bags	1	2
Filter Bag Diameter	19-1/2 in.	
Filter Bag Length	37 in.	
<b>Canister Information</b>		
Number of Canister Filters	1	2
Canister Filter Diameter	19-5/8 in.	
Canister Filter Length	29 in.	
<b>Impeller Information</b>		
Impeller Type	Radial Fan	
Impeller Size	12-3/4 in.	12-3/4 in.
Impeller Blade Thickness	1/8 in.	1/8 in.
<b>Construction</b>		
Filter Collection Bag	Clear Plastic	
Canister	Spun Bond Polyester	
Base	Steel	
Caster	Plastic	
Impeller	Aluminum	
Paint Type/Finish	Powder Coated	
Blower Housing	Steel	
Body	Steel	
<b>Manufacturer Specifications</b>		
Country of Origin	Taiwan	
Warranty	1 Year	
Approximate. Assembly & Setup Time	45 Minutes	1 Hour
Serial Number Location	ID Label	
Sound Rating	N/A	




# Understanding Risks of Machinery

Operating all machinery and machining equipment can be dangerous or relatively safe depending on how it is installed and maintained, and the operator's experience, common sense, risk awareness, working conditions, and use of personal protective equipment (safety glasses, respirators, etc.).

The owner of this machinery or equipment is ultimately responsible for its safe use. This responsibility includes proper installation in a safe environment, personnel training and usage authorization, regular inspection and maintenance, manual availability and comprehension, application of safety devices, integrity of cutting tools or accessories, and the usage of approved personal protective equipment by all operators and bystanders.

The manufacturer of this machinery or equipment will not be held liable for injury or property damage from negligence, improper training, machine modifications, or misuse. Failure to read, understand, and follow the manual and safety labels may result in serious personal injury, including amputation, broken bones, electrocution, or death.

The signals used in this manual to identify hazard levels are as follows:

 <b>DANGER</b>	<i>Death or catastrophic harm WILL occur.</i>	 <b>CAUTION</b>	<i>Moderate injury or fire MAY occur.</i>
 <b>WARNING</b>	<i>Death or catastrophic harm COULD occur.</i>	<b>NOTICE</b>	<i>Machine or property damage may occur.</i>

## Basic Machine Safety

**Owner's Manual:** All machinery and machining equipment presents serious injury hazards to untrained users. To reduce the risk of injury, anyone who uses THIS item MUST read and understand this entire manual before starting.

**Personal Protective Equipment:** Operating or servicing this item may expose the user to flying debris, dust, smoke, dangerous chemicals, or loud noises. These hazards can result in eye injury, blindness, long-term respiratory damage, poisoning, cancer, reproductive harm or hearing loss. Reduce your risks from these hazards by wearing approved eye protection, respirator, gloves, or hearing protection.

**Trained/Supervised Operators Only:** Untrained users can seriously injure themselves or bystanders. Only allow trained and properly supervised personnel to operate this item. Make sure safe operation instructions are clearly understood. If electrically powered, use padlocks and master switches, and remove start switch keys to prevent unauthorized use or accidental starting.

**Guards/Covers:** Accidental contact with moving parts during operation may cause severe entanglement, impact, cutting, or crushing injuries. Reduce this risk by keeping any included guards/covers/doors installed, fully functional, and positioned for maximum protection.

**Entanglement:** Loose clothing, gloves, neckties, jewelry or long hair may get caught in moving parts, causing entanglement, amputation, crushing, or strangulation. Reduce this risk by removing/securing these items so they cannot contact moving parts.

**Mental Alertness:** Operating this item with reduced mental alertness increases the risk of accidental injury. Do not let a temporary influence or distraction lead to a permanent disability! Never operate when under the influence of drugs/alcohol, when tired, or otherwise distracted.

**Safe Environment:** Operating electrically powered equipment in a wet environment may result in electrocution; operating near highly flammable materials may result in a fire or explosion. Only operate this item in a dry location that is free from flammable materials.

**Electrical Connection:** With electrically powered equipment, improper connections to the power source may result in electrocution or fire. Always adhere to all electrical requirements and applicable codes when connecting to the power source. Have all work inspected by a qualified electrician to minimize risk.

**Disconnect Power:** Adjusting or servicing electrically powered equipment while it is connected to the power source greatly increases the risk of injury from accidental startup. Always disconnect power **BEFORE** any service or adjustments, including changing blades or other tooling.

**Secure Workpiece/Tooling:** Loose workpieces, cutting tools, or rotating spindles can become dangerous projectiles if not secured or if they hit another object during operation. Reduce the risk of this hazard by verifying that all fastening devices are properly secured and items attached to spindles have enough clearance to safely rotate.

**Chuck Keys or Adjusting Tools:** Tools used to adjust spindles, chucks, or any moving/rotating parts will become dangerous projectiles if left in place when the machine is started. Reduce this risk by developing the habit of always removing these tools immediately after using them.

**Work Area:** Clutter and dark shadows increase the risks of accidental injury. Only operate this item in a clean, non-glaring, and well-lighted work area.

**Properly Functioning Equipment:** Poorly maintained, damaged, or malfunctioning equipment has higher risks of causing serious personal injury compared to those that are properly maintained. To reduce this risk, always maintain this item to the highest standards and promptly repair/service a damaged or malfunctioning component. Always follow the maintenance instructions included in this documentation.

**Unattended Operation:** Electrically powered equipment that is left unattended while running cannot be controlled and is dangerous to bystanders. Always turn the power **OFF** before walking away.

**Health Hazards:** Certain cutting fluids and lubricants, or dust/smoke created when cutting, may contain chemicals known to the State of California to cause cancer, respiratory problems, birth defects, or other reproductive harm. Minimize exposure to these chemicals by wearing approved personal protective equipment and operating in a well ventilated area.

**Difficult Operations:** Attempting difficult operations with which you are unfamiliar increases the risk of injury. If you experience difficulties performing the intended operation, **STOP!** Seek an alternative method to accomplish the same task, ask a qualified expert how the operation should be performed, or contact our Technical Support for assistance.

# Additional Dust Collector Safety

## ⚠️ WARNING

**Long-term respiratory damage can occur from using dust collectors without proper use of a respirator. Fire or explosions can result in smoke inhalation, serious burns, or death—if machine is used to collect incorrect materials, is operated near potential explosion sources, or ducting is improperly grounded. Entanglement, amputation, or death can occur if hair, clothing, or fingers are pulled into the inlet. To reduce the risk of these hazards, operator and bystanders MUST completely heed the hazards and warnings below.**

**Intended Use.** Collecting the wrong materials can result in serious inhalation hazards, fire, explosions, or machine damage. This machine is **ONLY** designed to collect wood dust and chips from woodworking machines. **DO NOT** use it to collect silica, polyurethane, toxic fumes, metal dust or shavings, lead paint, drywall, asbestos, biohazards, explosive dusts, flammable or combustible liquids or fumes, nor burning or smoking material.

**Wear a Respirator.** Fine dust that is too small to be caught in filter will be blown into ambient air. Always wear a NIOSH-approved respirator during operation and for a short time after to reduce your risk of permanent respiratory damage. Never collect dust from any hazardous material.

**Impeller Hazards.** To reduce risk of entanglement or contact with impeller, **DO NOT** place hands, hair, clothing, or tools in or near open dust collection inlet during operation, and keep small animals and children away. The powerful suction could easily pull them into impeller.

**Hazardous Dust.** Dust exposure created while using machinery may cause cancer, birth defects, or long-term respiratory damage. Be aware of dust hazards associated with each workpiece material, and always wear a NIOSH-approved respirator.

**Emptying Dust.** When emptying bag or drum, wear respirator and safety glasses. Empty dust away from ignition sources and into approved container.

**Operating Location.** To reduce respiratory exposure to fine dust, locate permanently installed dust collectors away from working area or in another room. **DO NOT** place dust collector where it can be exposed to rain or moisture, which creates a shock hazard and will reduce life of machine.

**Power Disconnect.** Turn machine **OFF**, disconnect from power supply, and allow impeller to completely stop before leaving machine unattended, or doing any maintenance or service.

**Regular Cleaning.** To reduce risk of starting a fire, regularly check/empty collection bags or drum to avoid buildup of fine dust, which can increase risk of fire. Regularly clean surrounding area where machine is operated—excessive dust buildup on overhead lights, heaters, electrical panels, or other heat sources will increase risk of fire.

**Suspended Dust Particles.** To reduce risk of death or injury caused by explosions or fires, **DO NOT** operate in areas where these risks are high, including spaces near pilot lights, open flames, or other ignition sources.

**Avoiding Sparks.** To reduce risk of fire, avoid collecting any metal objects or stones. These can possibly produce sparks when they strike impeller, which can smolder in wood dust for a long time before a fire is detected. If you accidentally cut into wood containing metal, immediately turn **OFF** dust collector, disconnect from power, and wait for impeller to stop. Then empty bag or drum into approved airtight metal container.

**Fire Suppression.** Only operate dust collector in locations that contain fire suppression system or have fire extinguisher nearby.

**Static Electricity.** To reduce risk of fire or explosions caused by sparks from static electricity, ground all ducting using grounding wire.

**Dust Allergies.** Dust from certain woods will cause an allergic reaction. Make sure you know what type of wood dust you will be exposed to in case of an allergic reaction.

## Preparation Overview

The purpose of the preparation section is to help you prepare your machine for operation. The list below outlines the basic process. Specific steps for each of these points will be covered in detail later in this section.

### The typical preparation process is as follows:

1. Unpack the machine and inventory the contents of the box/crate.
2. Clean the machine and its components.
3. Identify an acceptable location for the machine and move it to that location.
4. Assemble the loose components and make any necessary adjustments or inspections to ensure the machine is ready for operation.
5. Connect the machine to the power source.
6. Test run the machine to make sure it functions properly and is ready for operation.

### **WARNING**

Like all machinery there is potential danger when operating this machine. Accidents are frequently caused by lack of familiarity or failure to pay attention. Use this machine with respect and caution to decrease the risk of operator injury. If normal safety precautions are overlooked or ignored, serious personal injury may occur.

## Required for Setup

The items listed below are required to successfully set up and prepare this machine for operation.

### For Power Connection

- A power source that meets the minimum circuit requirements for this machine. (Refer to the **Power Supply Requirements** section for details.)
- A qualified electrician to ensure a safe and code-compliant connection to the power source.

### For Assembly

- An Assistant
- Safety Glasses (for each person)
- Phillips Screwdriver #2
- Wrench or Socket ½"

### **CAUTION**

No list of safety guidelines can be complete. Every shop environment is different. Always consider safety first, as it applies to your individual working conditions. Use this and other machinery with caution and respect. Failure to do so may result in serious personal injury or property damage.

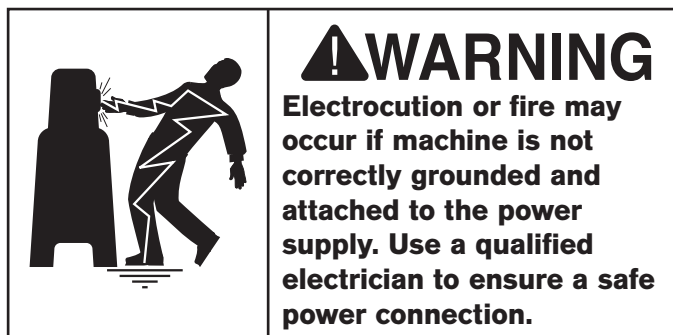


# Power Supply Requirements

## Availability

Before installing the machine, consider the availability and proximity of the required power supply circuit. If an existing circuit does not meet the requirements for this machine, a new circuit must be installed.

To minimize the risk of electrocution, fire, or equipment damage, installation work and electrical wiring must be done by an electrician or qualified service personnel in accordance with applicable electrical codes and safety standards.



## Full-Load Current Rating

The full-load current rating is the amperage a machine draws at 100% of the rated output power. On machines with multiple motors, this is the amperage drawn by the largest motor or sum of all motors and electrical devices that might operate at one time during normal operations.

**SB1100 at 220V ..... 9 Amps**  
**SB1101 at 240V ..... 12 Amps**

The full-load current is not the maximum amount of amps that the machine will draw. If the machine is overloaded, it will draw additional amps beyond the full-load rating.

If the machine is overloaded for a sufficient length of time, damage, overheating, or fire may result—especially if connected to an undersized circuit. To reduce the risk of these hazards, avoid overloading the machine during operation and make sure it is connected to a power supply circuit that meets the requirements in the following section.

## Circuit Information

A power supply circuit includes all electrical equipment between the main breaker box or fuse panel in your building and the incoming power connections inside the machine. This circuit must be safely sized to handle the full-load current that may be drawn from the machine for an extended period of time. (If this machine is connected to a circuit protected by fuses, use a time delay fuse marked D.)

**Note:** The circuit requirements in this manual are for a dedicated circuit—where only one machine will be running at a time. If this machine will be connected to a shared circuit where multiple machines will be running at the same time, consult a qualified electrician to ensure the circuit is properly sized.



## Grounding Requirements

This machine must be grounded! In the event of certain types of malfunctions or breakdowns, grounding provides a path of least resistance for electric current in order to reduce the risk of electric shock.

Improper connection of the equipment-grounding wire can result in a risk of electric shock. The wire with green insulation (with or without yellow stripes) is the equipment-grounding wire. If repair or replacement of the power cord or plug is necessary, do not connect the equipment-grounding wire to a live (current carrying) terminal.

Check with an electrician or qualified service personnel if you do not understand these grounding requirements, or if you are in doubt about whether the tool is properly grounded.

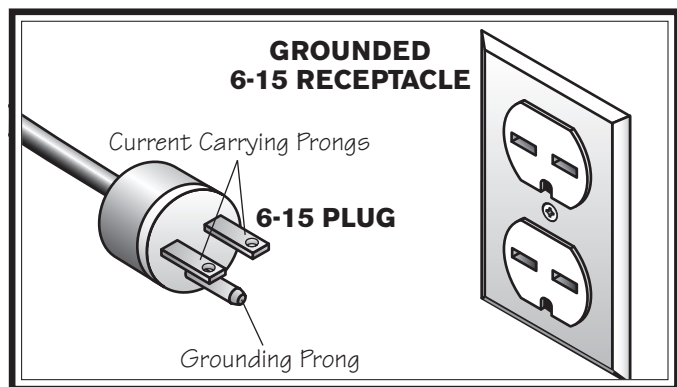
If you ever notice that a cord or plug is damaged or worn, disconnect it from power, and immediately replace it with a new one.

**SB1100 Circuit Information**

This machine is prewired to operate on a power supply circuit that has a verified ground and meets the following requirements:

**Nominal Voltage** ..... 220V  
**Cycle** ..... 60 Hz  
**Phase** ..... Single-Phase  
**Circuit Rating**..... 15 Amps  
**Plug/Receptacle (included)** ..... NEMA 6-15

This machine is equipped with a power cord that has an equipment-grounding wire and a grounding plug (similar to the figure below). The plug must only be inserted into a matching receptacle (outlet) that is properly installed and grounded in accordance with all local codes and ordinances.



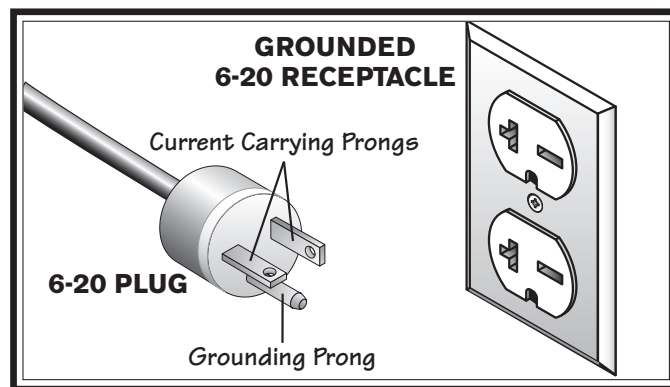
**Figure 3. NEMA 6-15 plug and receptacle.**

**SB1101 Circuit Information**

This machine is prewired to operate on a power supply circuit that has a verified ground and meets the following requirements:

**Nominal Voltage** ..... 240V  
**Cycle** ..... 60 Hz  
**Phase** ..... Single-Phase  
**Circuit Rating**..... 20 Amps  
**Plug/Receptacle (included)** ..... NEMA 6-20

This machine is equipped with a power cord that has an equipment-grounding wire and a grounding plug (similar to the figure below). The plug must only be inserted into a matching receptacle (outlet) that is properly installed and grounded in accordance with all local codes and ordinances.



**Figure 4. NEMA 6-20 plug and receptacle.**

**⚠ CAUTION**

**No adapter should be used with plug. If plug does not fit available receptacle, or if machine must be reconnected for use on a different type of circuit, reconnection must be performed by an electrician or qualified service personnel, and it must comply with all local codes and ordinances.**

**Extension Cords**

We do not recommend using an extension cord with this machine. If you must use one, only use it if absolutely necessary and only on a temporary basis.

Extension cords cause voltage drop, which may damage electrical components and shorten motor life. Voltage drop increases as the extension cord size gets longer and the gauge size gets smaller (higher gauge numbers indicate smaller sizes).

Any extension cord used with this machine must contain a ground wire, match the required plug and receptacle listed in the **Circuit Requirements** for the applicable voltage, and meet the following requirements:

**SB1100** ..... 14 AWG, 50 ft or less  
**SB1101** ..... 12 AWG, 50 ft or less

# Unpacking

This item was carefully packaged to prevent damage during transport. If you discover any damage, please immediately call Customer Service at (360) 734-1540 for advice. You may need to file a freight claim, so save the containers and all packing materials for possible inspection by the carrier or its agent.

## SB1100 Inventory

Main Inventory (Figure 5)		Qty
<b>A.</b>	Motor/Impeller Assembly .....	1
<b>B.</b>	Outlet Tube .....	1
<b>C.</b>	Collector.....	1
<b>D.</b>	Switch Box.....	1
<b>E.</b>	Base .....	1
<b>F.</b>	Gauge Bracket.....	1
<b>G.</b>	Pressure Gauge .....	1
<b>H.</b>	Hose 1/2" .....	1
<b>I.</b>	Collection Bag .....	1
<b>J.</b>	Square Gaskets .....	2
<b>K.</b>	Bag Clamp .....	1
<b>L.</b>	Canister Support.....	1
<b>M.</b>	Swivel Casters.....	4
<b>N.</b>	Inlet Adapter .....	1
<b>O.</b>	Upper Alignment Arm .....	1
<b>P.</b>	Filter Motor Hardware Bag.....	1
	— Cap Screws M4-.7 x 60 .....	4
	— Lock Washers 4mm .....	4
	— Flat Washers 4mm .....	4
	— Hex Nuts M4-.7 .....	4
<b>Q.</b>	Hose Clamps 3/4" .....	2
<b>R.</b>	Filter Cover .....	1
<b>S.</b>	Lower Alignment Arm .....	1
<b>T.</b>	Filter Brush Motor.....	1
<b>U.</b>	Gear Reducer.....	1
<b>V.</b>	Hex Bolts M6-1 x 16.....	2
<b>W.</b>	Hex Nuts 10-24 .....	2
<b>X.</b>	Phillips Head Screws 10-24 x 3/4".....	2
<b>Y.</b>	Flange Nuts 1/4"-20 .....	2
<b>Z.</b>	Button Head Cap Screws 1/4"-20 x 1/2".....	2
<b>AA.</b>	Flange Bolts 1/4"-20 x 3/4".....	6
<b>AB.</b>	Flange Bolts 5/16"-18 x 1/2" .....	38
<b>AC.</b>	Flange Bolts 5/16"-18 x 3/4" .....	2
<b>AD.</b>	Flange Screw 10-24 x 3/8" .....	1

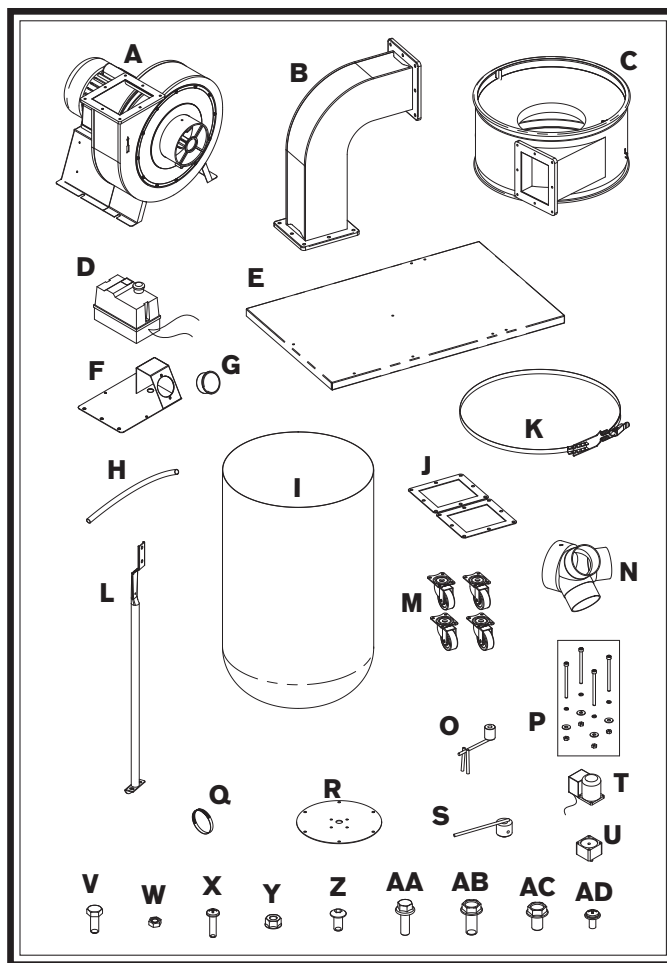


Figure 5. SB1100 main inventory.

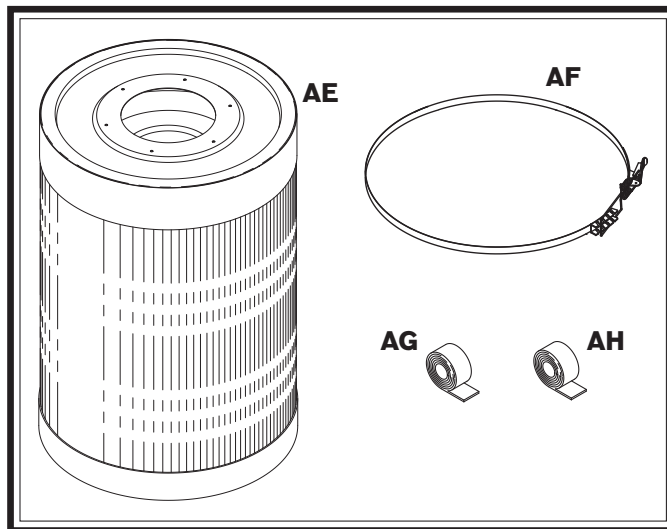


Figure 6. SB1100 canister filter inventory.

Filter Box (Figure 6)	Qty	
<b>AE.</b>	Canister Filter Assembly.....	1
<b>AF.</b>	Canister Clamp .....	1
<b>AG.</b>	Foam Tape 5 x 42mm .....	1
<b>AH.</b>	Foam Tape 5 x 20mm .....	1

# SB1101 Inventory

## Main Inventory (Figure 7)

	<b>Qty</b>
<b>A.</b> Motor/Impeller Assembly .....	1
<b>B.</b> Outlet Tube .....	1
<b>C.</b> Right Collector .....	1
<b>D.</b> Switch Box.....	1
<b>E.</b> Base .....	1
<b>F.</b> Left Collector.....	1
<b>G.</b> Gauge Bracket.....	1
<b>H.</b> Pressure Gauge .....	1
<b>I.</b> Square Gaskets .....	3
<b>J.</b> Hose ½".....	1
<b>K.</b> Swivel Casters.....	4
<b>L.</b> Inlet Adapter .....	1
<b>M.</b> Collection Bags.....	2
<b>N.</b> Canister Supports .....	2
<b>O.</b> Bag Clamps .....	2
<b>P.</b> Filter Motor Hardware Bags .....	2
— Cap Screws M4-.7 x 60 .....	8
— Lock Washers 4mm .....	8
— Flat Washers 4mm .....	8
— Hex Nuts M4-.7 .....	8
<b>Q.</b> Hose Clamps ¾" .....	2
<b>R.</b> Filter Covers.....	2
<b>S.</b> Upper Alignment Arms .....	2
<b>T.</b> Filter Brush Motors .....	2
<b>U.</b> Lower Alignment Arms .....	2
<b>V.</b> Gear Reducers .....	2
<b>W.</b> Hex Bolts M6-1 x 16.....	4
<b>X.</b> Hex Nuts 10-24 .....	2
<b>Y.</b> Phillips Head Screws 10-24 x ¾".....	2
<b>Z.</b> Flange Nuts ¼"-20 .....	2
<b>AA.</b> Button Head Cap Screws ¼"-20 x ½".....	2
<b>AB.</b> Flange Bolts ¼"-20 x ¾".....	12
<b>AC.</b> Flange Bolts ⅕"-18 x ½" .....	48
<b>AD.</b> Flange Bolts ⅕"-18 x ¾" .....	4
<b>AE.</b> Flange Screw 10-24 x ⅜" .....	1

## Filter Box 1 (Figure 8)

	<b>Qty</b>
<b>AF.</b> Canister Filter Assembly.....	1
<b>AG.</b> Canister Clamp .....	1
<b>AH.</b> Foam Tape 5 x 42mm .....	1
<b>AI.</b> Foam Tape 5 x 20mm .....	1

## Filter Box 2 (Figure 8)

	<b>Qty</b>
<b>AF.</b> Canister Filter Assembly.....	1
<b>AG.</b> Canister Clamp .....	1
<b>AH.</b> Foam Tape 5 x 42mm .....	1
<b>AI.</b> Foam Tape 5 x 20mm .....	1

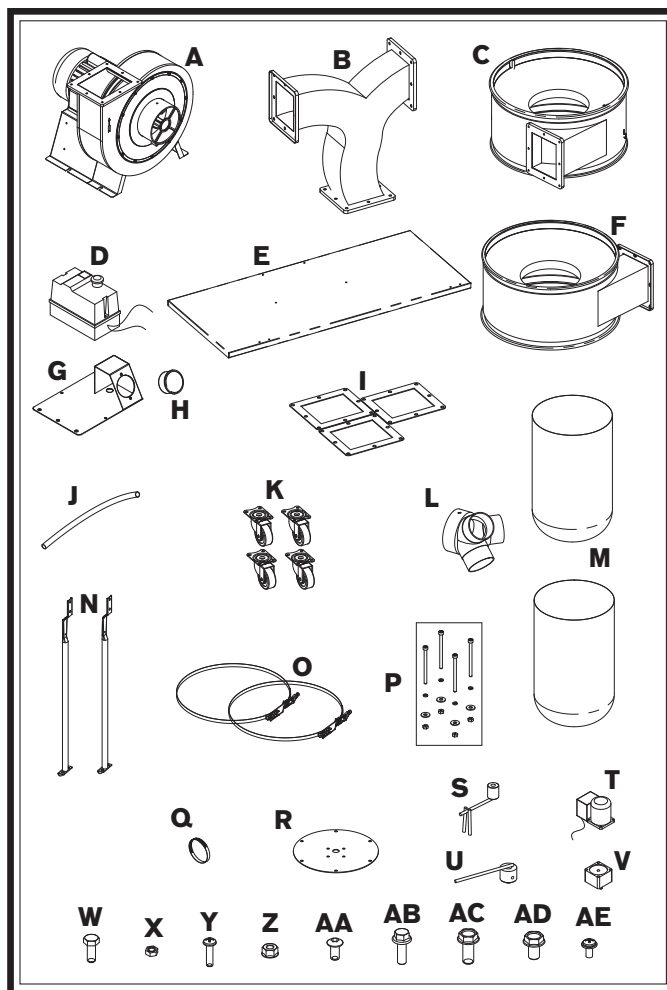


Figure 7. SB1101 main inventory.

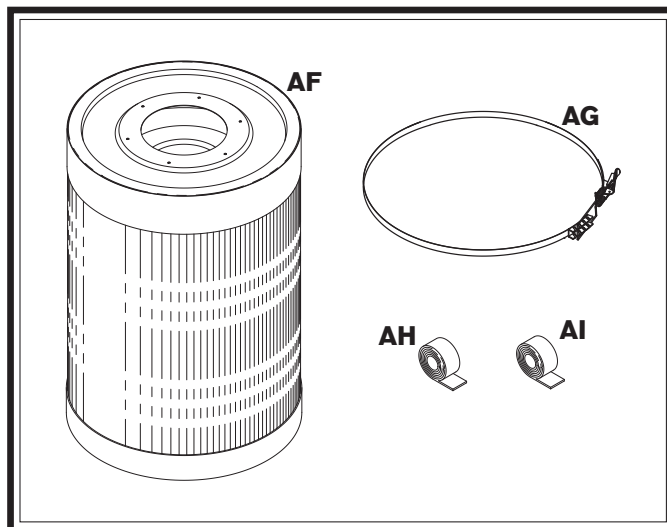


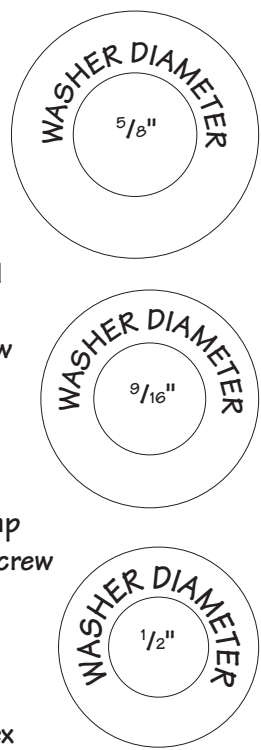
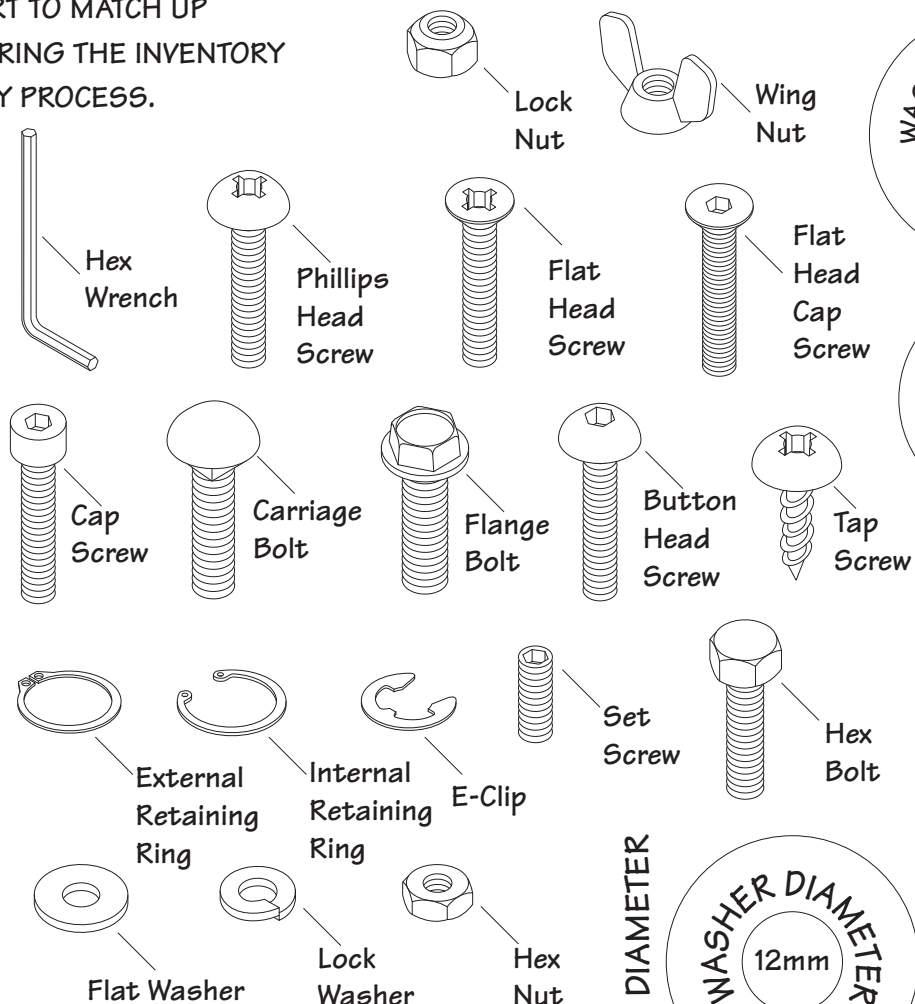
Figure 8. SB1101 canister filter inventory.

# Hardware Recognition Chart

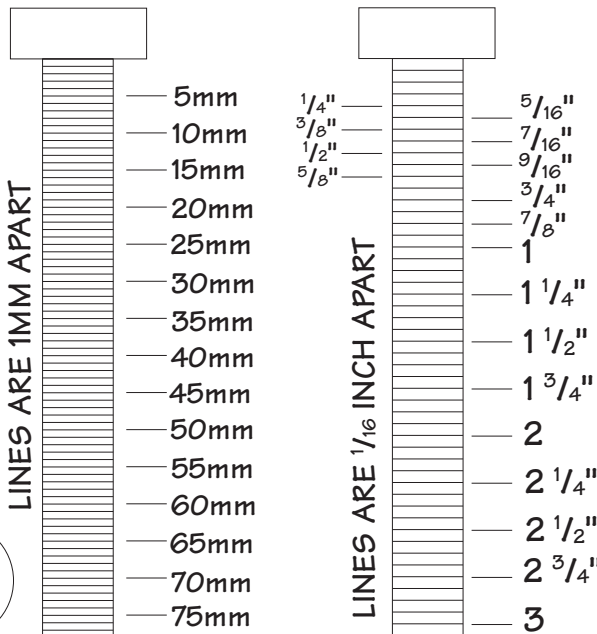
USE THIS CHART TO MATCH UP  
HARDWARE DURING THE INVENTORY  
AND ASSEMBLY PROCESS.

MEASURE BOLT DIAMETER BY PLACING INSIDE CIRCLE

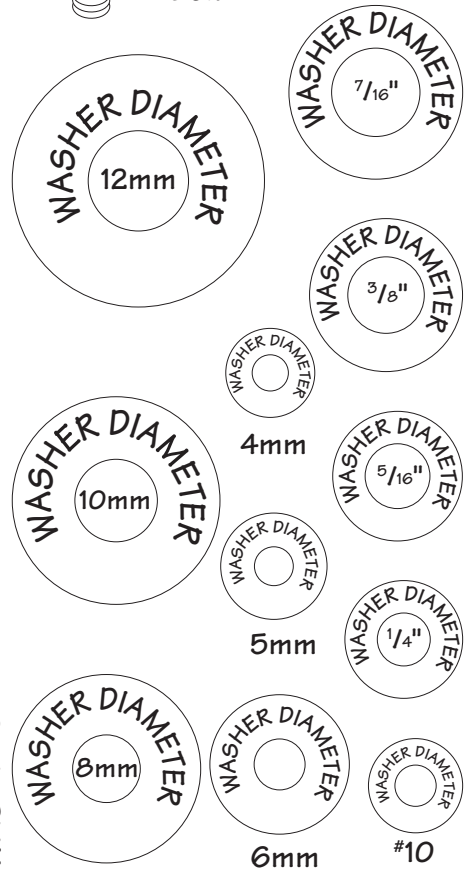
- #10
- 1/4"
- 5/16"
- 3/8"
- 7/16"
- 1/2"



- 4mm
- 5mm
- 6mm
- 8mm
- 10mm
- 12mm
- 16mm



WASHERS ARE MEASURE BY THE INSIDE DIAMETER





# Location

## Physical Environment

The physical environment where your machine is operated is important for safe operation and longevity of parts. For best results, operate this machine in a dry environment that is free from excessive moisture, hazardous or flammable chemicals, airborne abrasives, or extreme conditions. Extreme conditions for this type of machinery are generally those where the ambient temperature is outside the range of 41°–104°F; the relative humidity is outside the range of 20–95% (non-condensing); or the environment is subject to vibration, shocks, or bumps.

## Electrical Installation

Place this machine near an existing power source. Make sure all power cords are protected from traffic, material handling, moisture, chemicals, or other hazards. Make sure to leave access to a means of disconnecting the power source or engaging a lockout/tagout device.

## Lighting

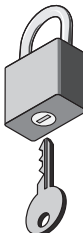
Lighting around the machine must be adequate enough to perform operations safely. Shadows, glare, or strobe effects that may distract or impede the operator must be eliminated.

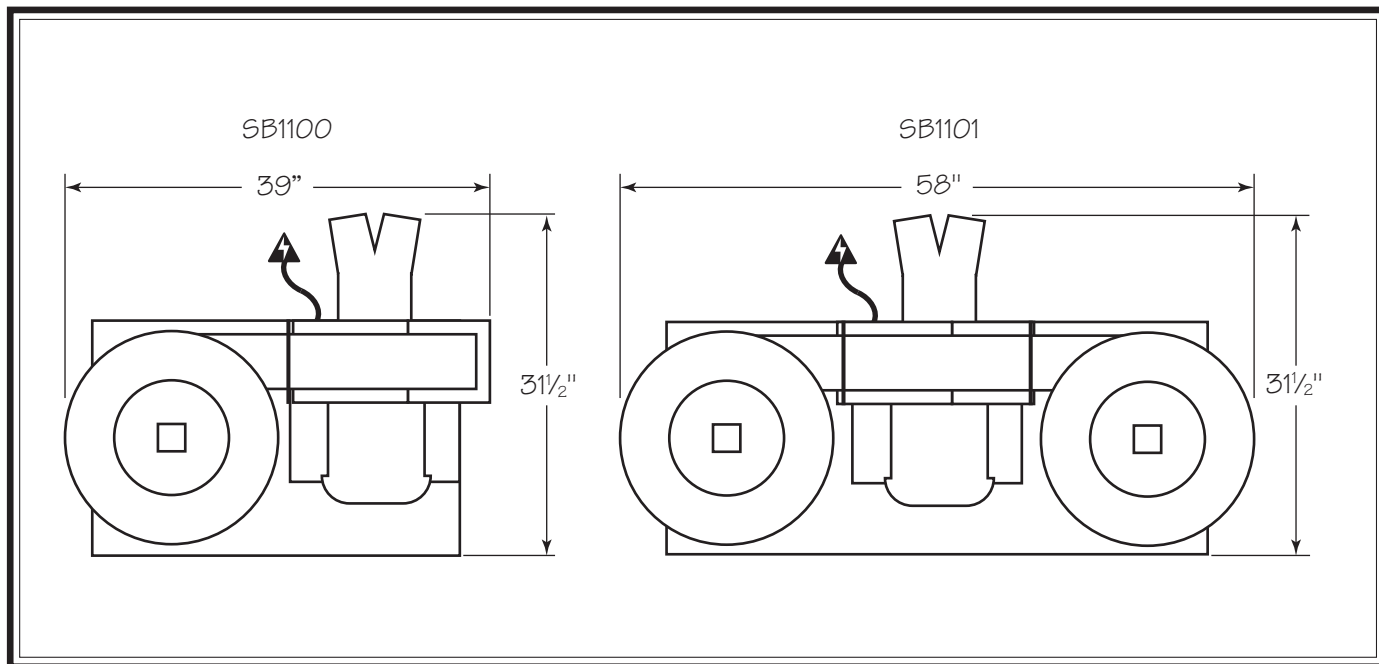
## Weight Load

Refer to the **Machine Specifications** for the weight of your machine. Make sure that the surface upon which the machine is placed will bear the weight of the machine, additional equipment that may be installed on the machine, and the heaviest workpiece that will be used. Additionally, consider the weight of the operator and any dynamic loading that may occur when operating the machine.

## Space Allocation

Consider the largest size of workpiece that will be processed through this machine and provide enough space around the machine for adequate operator material handling or the installation of auxiliary equipment. With permanent installations, leave enough space around the machine to open or remove doors/covers as required by the maintenance and service described in this manual.

	<p><b>⚠ CAUTION</b>  <b>Children or untrained people may be seriously injured by this machine. Only install in an access restricted location.</b></p>
--	---



**Figure 9. Clearances.**

# Assembly

The machine must be fully assembled before it can be operated. Before beginning the assembly process, refer to **Needed for Setup** and gather all listed items. To ensure the assembly process goes smoothly, first clean any parts that are covered or coated in heavy-duty rust preventative (if applicable).

## To assemble dust collector:

1. Attach (4) swivel casters to base with (16)  $\frac{5}{16}$ "-18 x  $\frac{1}{2}$ " flange bolts (see **Figure 10**).

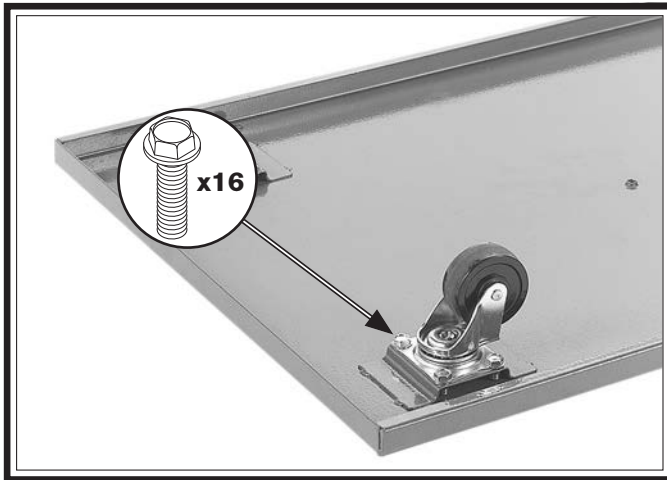


Figure 10. Example of swivel caster attached to base.

2. Align motor/impeller assembly with mounting holes on base. Attach assembly to base with (4)  $\frac{5}{16}$ "-18 x  $\frac{1}{2}$ " flange bolts (see **Figure 11**).

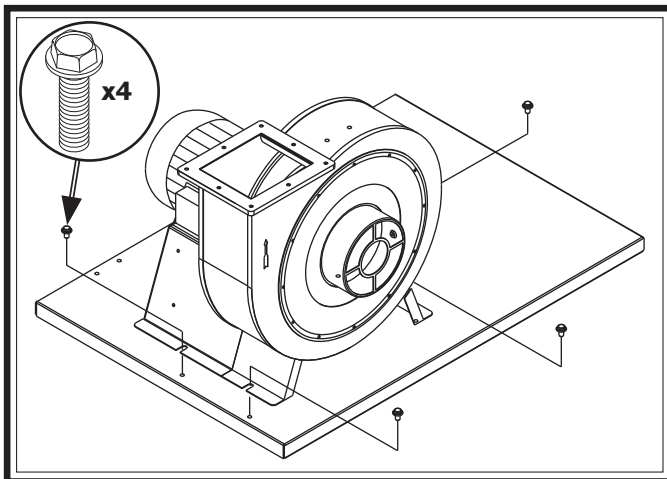


Figure 11. Motor/impeller assembly on base.

3. Place square gasket on impeller outlet rim (see **Figure 12**).



Figure 12. Square gasket in place on impeller rim.

4. Attach outlet tube to impeller outlet with (5)  $\frac{5}{16}$ "-18 x  $\frac{1}{2}$ " flange bolts (see **Figures 13 & 14**). Do not use three inner mounting holes.

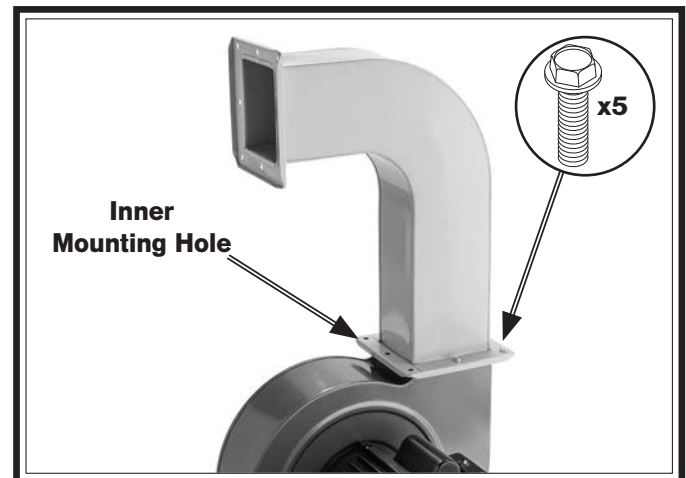


Figure 13. SB1100 outlet tube attached.

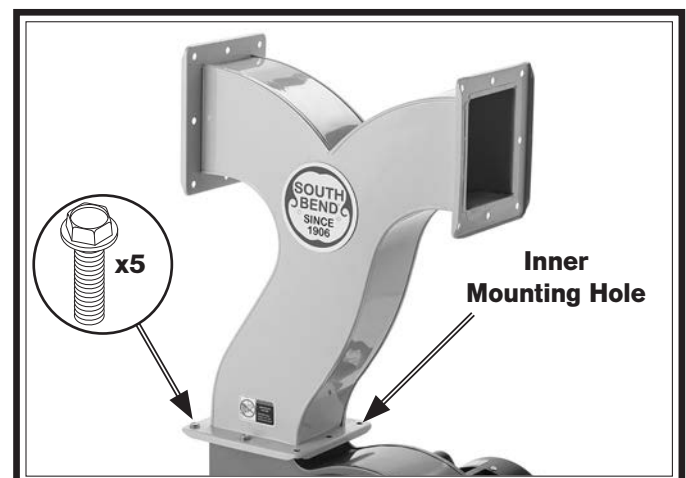
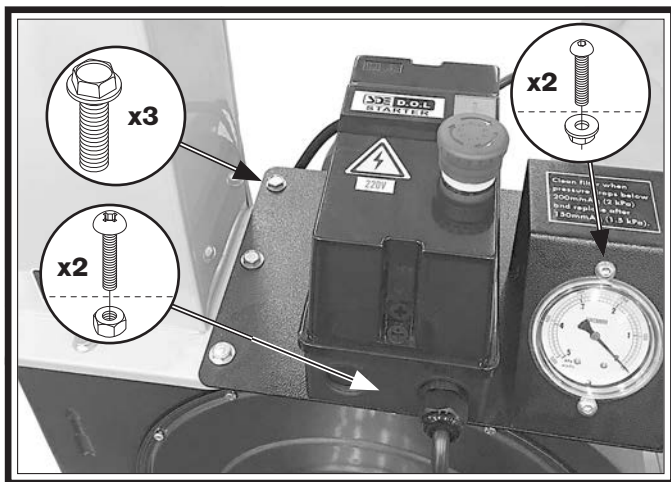


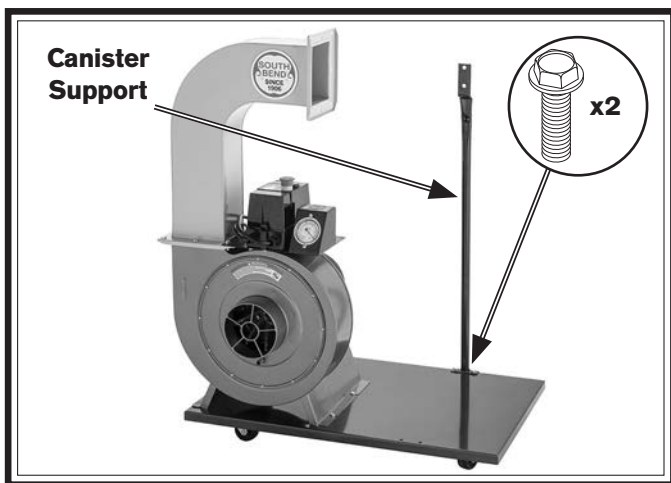
Figure 14. SB1101 outlet tube attached.

5. Attach pressure gauge to gauge bracket using (2)  $\frac{1}{4}$ "-20 x  $\frac{1}{2}$ " button head cap screws and  $\frac{1}{4}$ "-20 flange nuts (see **Figure 15**).
6. Attach gauge bracket to outlet tube with (3)  $\frac{5}{16}$ "-18 x  $\frac{1}{2}$ " flange bolts using remaining mounting holes (see **Figure 15**).
7. Loosen existing Phillips head screws and remove switch box cover from switch box (see **Figure 15**).
8. Attach switch box to gauge bracket with (2) 10-24 x  $\frac{3}{4}$ " Phillips head screws and 10-24 hex nuts (see **Figure 15**).



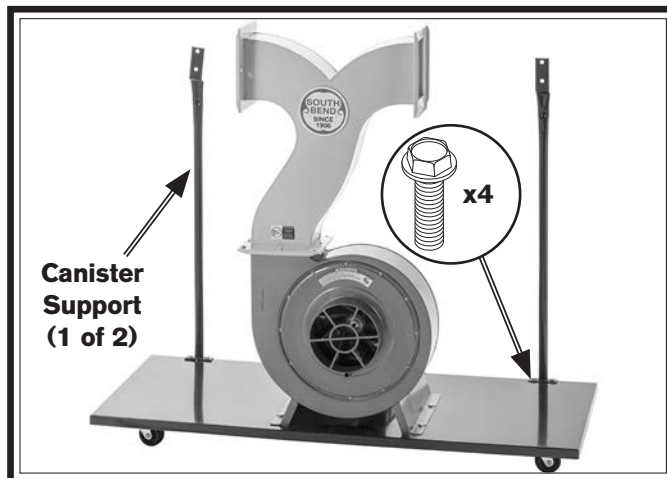
**Figure 15.** Switch box mounted on outlet tube.

9. Attach canister support to base with (2)  $\frac{5}{16}$ "-18 x  $\frac{1}{2}$ " flange bolts (see **Figure 16**).



**Figure 16.** SB1100 canister support.

10. **SB1101 Only:** Repeat **Step 9** with second canister support (see **Figure 17**).

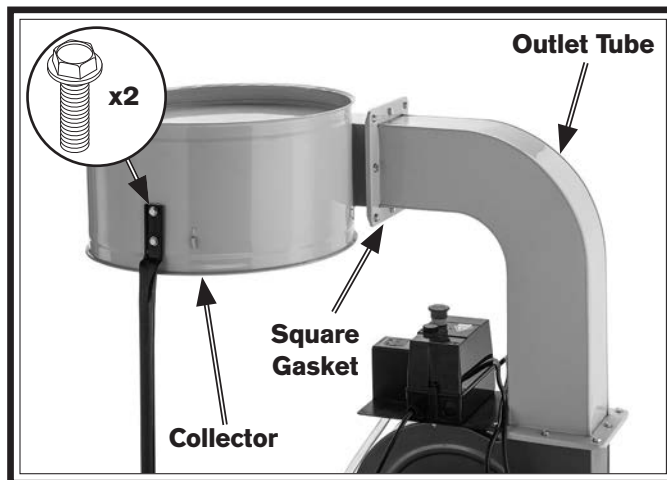


**Figure 17.** SB1101 canister support.

11. While an assistant holds collector, insert square gasket between collector and outlet tube, then secure collector to outlet tube with (8)  $\frac{5}{16}$ "-18 x  $\frac{1}{2}$ " flange bolts (see **Figure 18**).

**IMPORTANT:** Collector must be oriented so canister support aligns with mounting holes on collector.

12. Attach canister support to collector with (2)  $\frac{5}{16}$ "-18 x  $\frac{3}{4}$ " flange bolts (see **Figure 18**).

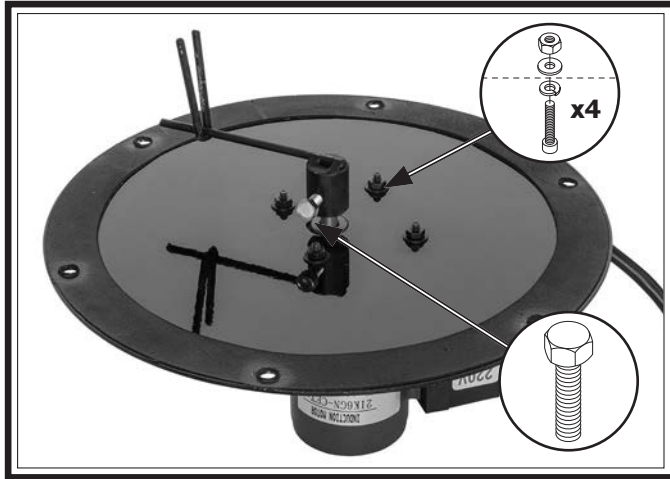


**Figure 18.** Collector attached to outlet tube and canister support.

13. **SB1101 Only:** Repeat **Steps 11–12** with second collector.

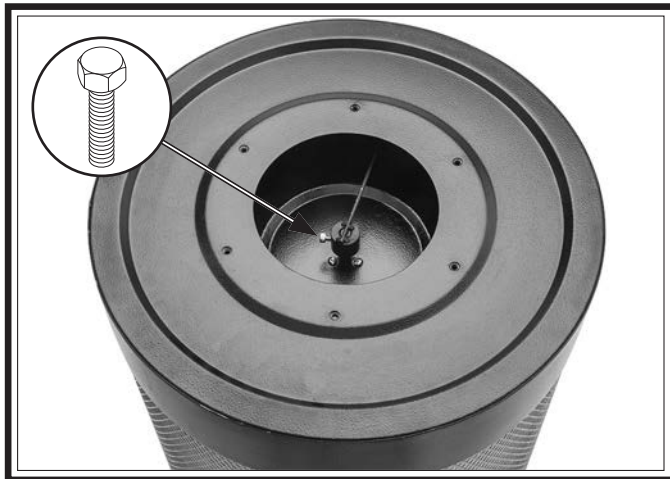
**14.** Attach filter brush motor and gear reducer to filter cover with (4) M4-.7 x 60 cap screws, 4mm lock washers, 4mm flat washers, and M4-.7 hex nuts (see **Figure 19**).

**15.** Attach upper alignment arm to gear reducer spindle with M6-1 x 16 hex bolt (see **Figure 19**).



**Figure 19.** Filter cover assembly.

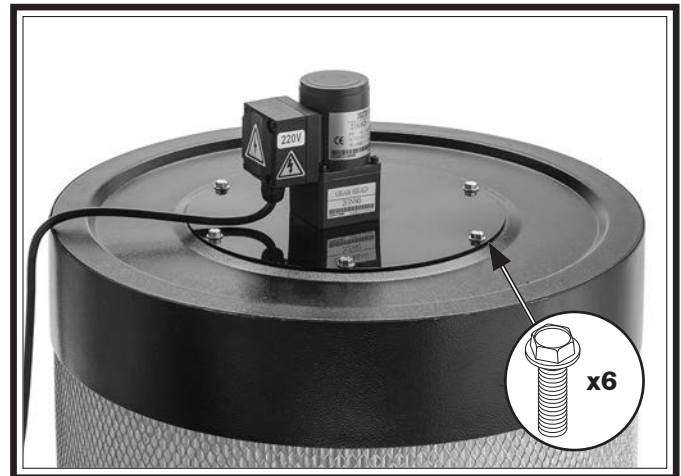
**16.** Attach lower alignment arm to filter spindle with M6-1 x 16 hex bolt (see **Figure 20**).



**Figure 20.** Lower alignment arm installed to filter spindle.

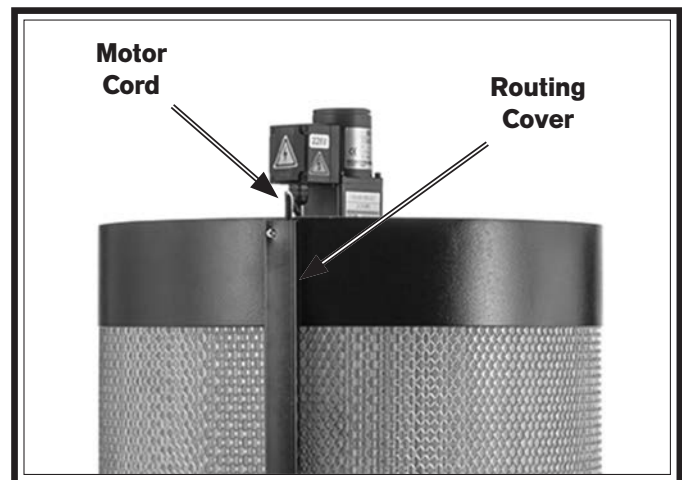
**17.** Position filter cover assembly over canister filter. Rotate lower alignment arm so "V" on upper alignment arm captures lower arm when mounting holes align.

**18.** Attach filter cover assembly to canister filter with (6) ¼"-20 x ¾" flange bolts (see **Figure 21**).



**Figure 21.** Filter cover assembly attached to canister filter.

**19.** Pull motor cord from filter brush motor through routing cover on canister filter (see **Figure 22**).



**Figure 22.** Filter brush motor cord and routing cover.

**20. SB1101 Only:** Repeat Steps 14–19 with second canister filter.



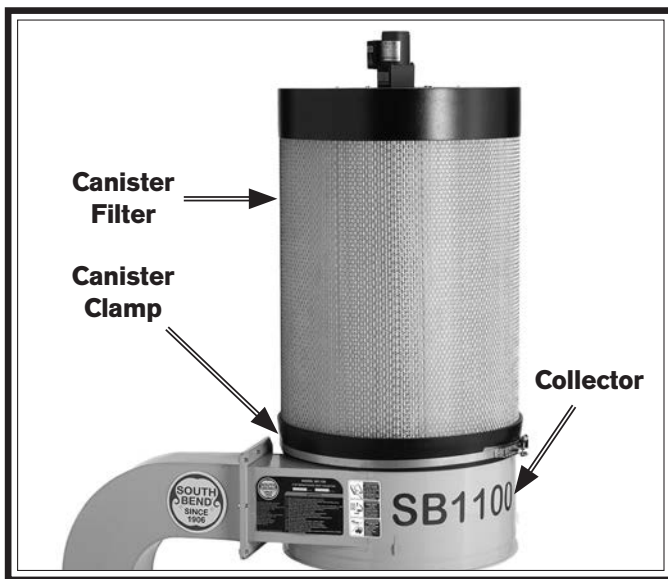
- 21.** Apply 42mm foam tape to outside top rim of collector (see **Figure 23**). Trim excess tape so ends meet evenly without overlap or gap.

**Note:** *DO NOT stretch tape when applying it to collector. Stretched tape will shrink and leave a gap, greatly reducing efficiency.*



**Figure 23.** Tape applied to top rim of collector.

- 22.** Position canister clamp around base of canister filter, then place canister filter over collector and tighten clamp (see **Figure 24**).



**Figure 24.** Canister filter secured to collector with bag clamp.

- 23. SB1101 Only:** Repeat Steps 20–21 with second canister filter.

- 24.** Apply 20mm foam tape to outside bottom rim of collector (see **Figure 25**). Trim excess tape so ends meet evenly without overlap or gap.



**Figure 25.** Tape applied to bottom rim of collector.

- 25.** Attach collection bag to hooks around bottom of collector, then position bag clamp around collector and tighten clamp around bag (see **Figure 26**).

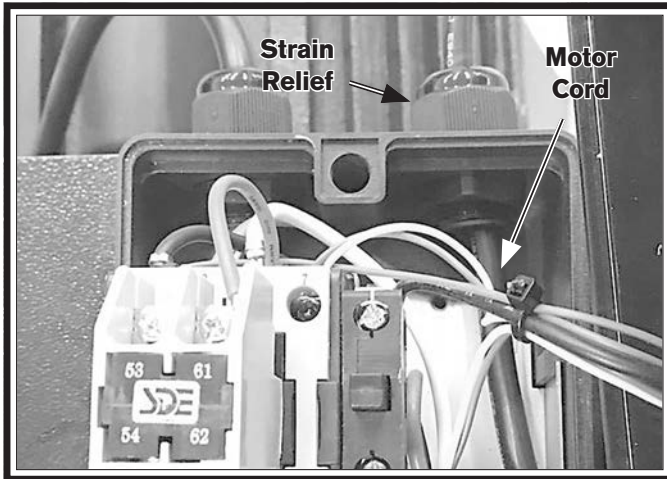


**Figure 26.** Collection bag installed to dust collector.

- 26. SB1101 Only:** Repeat Steps 23–24 with second collector.



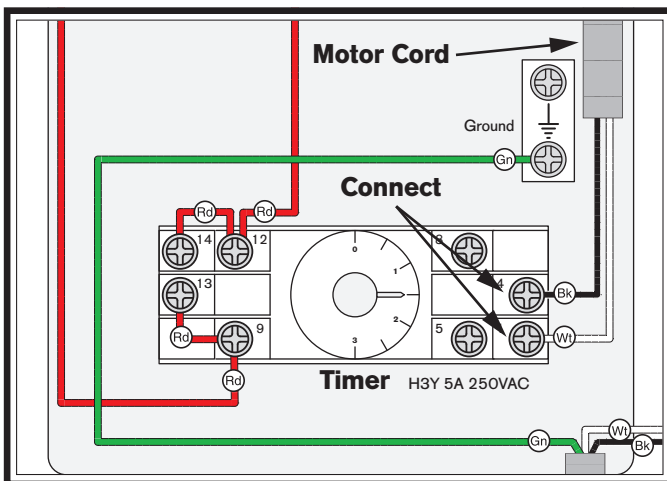
27. Pull motor cord from filter brush motor through strain relief at top of switch box (see **Figure 27**).



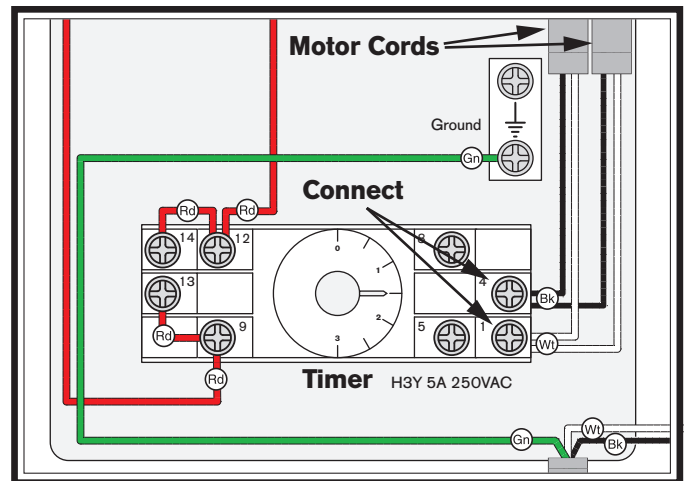
**Figure 27.** Filter brush motor cord routed into switch box.

28. **SB1101 Only:** Repeat **Step 26** with second filter brush motor cord.
29. Connect terminal ends of motor cord(s) to right terminals of timer inside switch box (see **Figures 28** and **29**).

**Note:** *Timer module may be pulled off terminal block if it is in the way during connection of motor cords.*



**Figure 28.** SB1100 filter brush motor connection.



**Figure 29.** SB1101 filter brush motor connection.

**Note:** *For full wiring diagrams, refer to SB1100 Wiring Diagram on **Page 45** and SB1101 Wiring Diagram on **Page 48**.*

30. Tighten strain relief (see **Figure 27**) to secure motor cords in position.
31. Attach switch box cover to switch box with (2) Phillips head screws loosened in **Step 7**.
32. Attach ½" hose to pressure gauge and port under impeller intake with and (2) ¾" hose clamps (see **Figure 30**).
33. Attach inlet adapter to impeller intake, then secure inlet adapter with (1) 10-24 x ¾" flange screw (see **Figure 30**).



**Figure 30.** Inlet adapter secured to impeller housing.

## Test Run

After all preparation steps have been completed, the machine and its safety features must be tested to ensure correct operation. If you discover a problem with the operation of the machine or its safety components, do not operate it further until you have resolved the problem.

**Note:** Refer to **Troubleshooting on Page 42** for solutions to common problems. If you need additional help, contact our Tech Support at (360) 734-1540.

The test run consists of verifying the following:

- Motor powers up and runs correctly.
- Emergency Stop button works correctly.
- Remote control works correctly.

### WARNING

**Serious injury or death can result from using this machine BEFORE understanding its controls and related safety information. DO NOT operate, or allow others to operate, machine until the information is understood.**

### WARNING

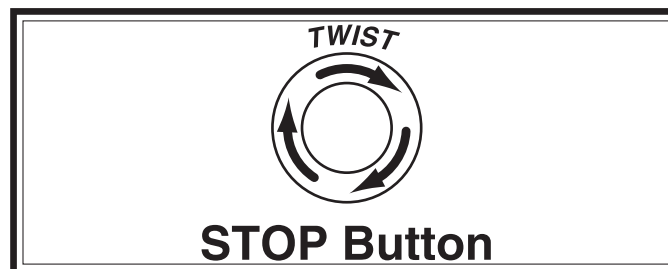
**DO NOT start machine until all preceding setup instructions have been performed. Operating an improperly set up machine may result in malfunction or unexpected results that can lead to serious injury, death, or machine/property damage.**

#### To test run machine:

1. Clear all setup tools away from machine.
2. Lock all swivel casters on base stand.
3. Connect machine to dust-collection system or place covers over inlet adapter ports.

**IMPORTANT:** *DO NOT operate the dust collector without first connecting it to a dust-collection system or covering an inlet adapter port. Otherwise, the lack of airflow resistance will cause the motor to operate at full amperage load, which could trip your circuit breaker or blow a fuse.*

4. Press Emergency Stop button in.
5. Connect machine to power.
6. Twist Emergency Stop button clockwise until it springs out (see **Figure 31**). This resets the switch so the machine can start.



**Figure 31. Resetting the switch.**

7. Standing away from intake port, press green Start button to turn machine **ON**. Verify motor starts up and runs smoothly without any problems or unusual noises.
8. Press Emergency Stop button to turn machine **OFF**.
9. **WITHOUT** resetting Emergency Stop button, try to start machine by pressing the green Start button. The machine should not start.
  - If the machine does not start, the safety feature of the Emergency Stop button is working correctly.
  - If the machine does start, immediately turn it **OFF** and disconnect power. The safety feature of the Emergency Stop button is **NOT** working properly and must be replaced before further using the machine.
10. To test remote control operation, reset Emergency Stop button then press remote **ON** button to turn motor **ON**, then press remote **OFF** button to turn motor **OFF**.
  - If the machine does **NOT** start or stop, press Emergency Stop button to turn machine **OFF**. Refer to **Pairing Remote Control & Receiver on Page 41** and ensure remote control is paired.

Congratulations! The Test Run is complete.

## General

### ⚠ CAUTION

Always make sure there are no open flames or pilot lights in the same room as the dust collector. There is a risk of explosion if too much fine dust is dispersed into the air with an open flame present.



### ⚠ CAUTION

Always guard against static electrical buildup by grounding all dust collection lines.

The Model SB1100/SB1101 works quite well as a point-of-use dust collector, or for collecting dust from up to three machines simultaneously. The locking swivel casters make it easy to move around the shop near the machine being used.

## Tips for Optimum Performance

- Avoid using more than 10' of flexible hose on any ducting line. The ridges inside flexible hose greatly increase static pressure loss, which reduces suction performance.
- Keep ducts between the dust collector and machines as short as possible.
- Keep ducting directional changes to a minimum. The more curved fittings you use, the greater the loss of suction at the dust-producing machine.
- Gradual directional changes are more efficient than sudden directional changes (i.e. use 45° elbows in place of 90° elbows whenever possible).
- The simpler the system, the more efficient and less costly it will be.

## Duct Material

You have many choices regarding main line and branch line duct material. For best results, use smooth metal duct for the main line and branch lines, then use short lengths of flexible hose to connect each machine to the branch lines.

Plastic duct is also a popular material for home shops. However, be aware that there is a fire or explosion hazard if plastic duct material is not properly grounded to prevent static electrical buildup (refer to **System Grounding** at the end of this section). Another problem with using plastic duct is that it is less efficient per foot than metal.



### ⚠ CAUTION

Plastic duct generates static electrical buildup that can cause fire or shock. Properly ground it to reduce this risk.

## Plastic Duct

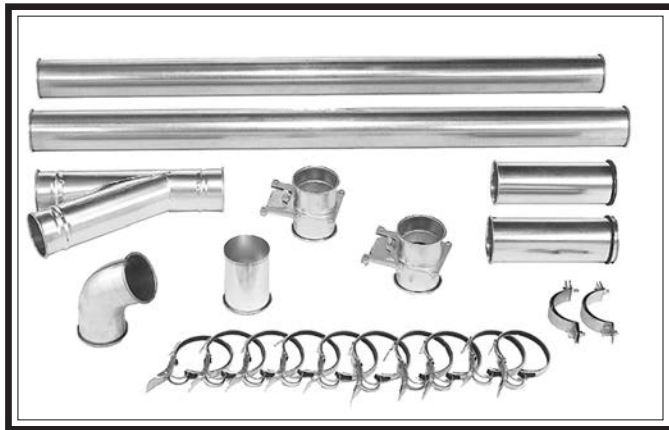
The popularity of plastic duct is due to the fact that it is an economical and readily available product. It is also simple to assemble and easily sealed against air loss. The primary disadvantage of plastic duct for dust collection is the inherent danger of static electrical buildup.



Figure 32. Examples of plastic ducting components.

## Metal Duct

Advantages of smooth metal duct are its conductivity, efficiency, and that it does not contribute to static electrical charge build-up. However, static charges are still produced when dust particles strike other dust particles as they move through the duct. Since metal duct is a conductor, it can be grounded quite easily to dissipate any static electrical charges.



**Figure 33. Examples of smooth metal duct and components.**

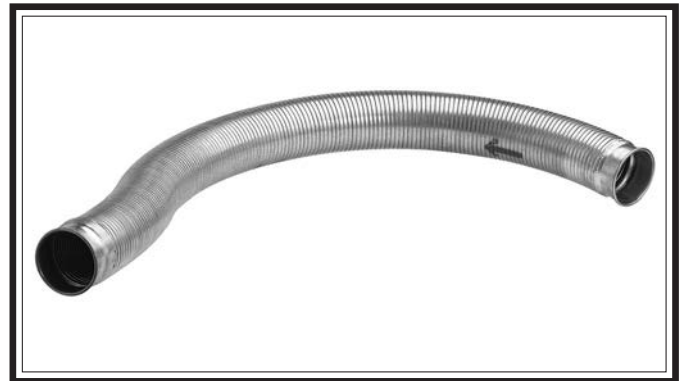
There are a number of options when it comes to metal duct, but metal duct that is specially manufactured for dust collection is the best choice. When selecting your metal duct, choose high quality metal duct with smooth welded internal seams that will minimize airflow resistance. This type of duct usually connects to other ducts or elbows with a simple, self-sealing clamp, is very quick and easy to assemble, and can be readily dismantled and re-installed in a different configuration. This is especially important if you ever need to change things around in your shop or add more tools.

Avoid inferior metal duct that requires you to cut it to length and snap it together. This type of duct is time consuming to install because it requires you to seal all the seams with silicone and screw the components on the ends with sheet metal screws. Another disadvantage is the rough internal seams and crimped ends that unavoidably increase static pressure loss.

## Flexible Duct

Flexible hose is generally used for short runs, small shops and at rigid duct-to-tool connections. There are many different types of flex hose on the market today. These are manufactured from materials such as polyethylene, PVC, cloth hose dipped in rubber and even metal, including steel and aluminum.

The superior choice here is metal flex hose that is designed to be flexible, yet be as smooth as possible inside to reduce static pressure loss.



**Figure 34. Example of flexible metal duct.**

There are also many kinds of pure plastic flexible hose, such as non-perforated drainage type hose and dryer vent hose. Drainage type hose, while being economical, does not quite have the flexibility required for dust collection. The inside of the duct is also deeply corrugated and can increase the static pressure loss by as much as 50% over smooth wall duct. Dryer vent hose, while being completely flexible, is non-resistant to abrasion and has a tendency to collapse in a negative pressure system. We DO NOT recommend using dryer vent hose in your dust collection system.

If using flex-hose, you should choose one of the many types that are designed specifically for the movement of solid particles, i.e. dust, grains, and plastics. However, the cost of specifically designed flexible duct can vary greatly. Grizzly.com offers polyethylene hose, which is well suited for the removal of particulate matter, especially sawdust, since it is durable and completely flexible. Polyethylene is also very economical and available in a wide variety of diameters and lengths for most applications.



# System Design

## Decide Who Will Design

For most small-to-medium sized shops, you can design and build the dust collection system yourself without hiring engineers or consultants. We have included some basic information here to get you started on a basic design.

If you have a large shop or plan to design a complicated system, we recommend doing additional research beyond this manual or seeking the help of an expert.

## Sketch Your Shop Layout

When designing a successful dust collection system, planning is the most important step. In this step, sketch a basic layout of your shop, including space requirements of different machines.

Your sketch only needs the basic details of the shop layout, similar to the figure below, including all your current/planned machines and your planned placement of the dust collector.

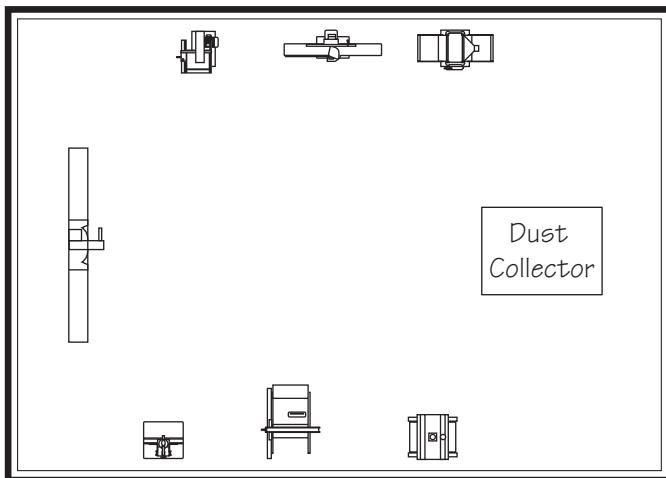


Figure 35. Basic sketch of shop layout.

## Sketch a Basic Duct Layout

For the next step, sketch how you will connect your machines to the dust collector. Consider these general guidelines for an efficient system:

1. Machines that produce the most saw dust should be placed nearest to the dust collector (i.e. planers and sanders).
2. Ideally, you should design the duct system to have the shortest possible main line and secondary branch ducts. See the figures below for ideas of efficient versus inefficient duct layouts.

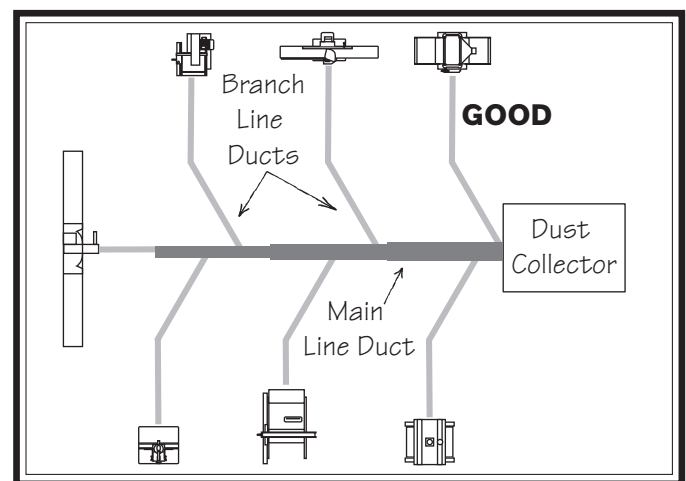


Figure 36. Efficient duct layout.

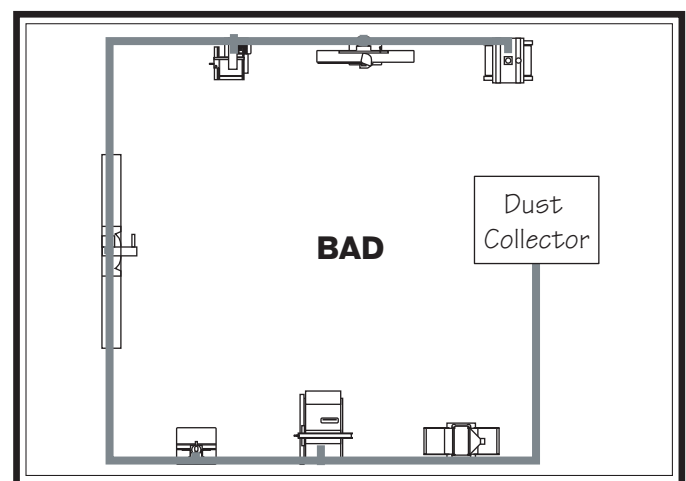


Figure 37. Inefficient duct layout.

3. Directional changes should be kept to a minimum. The more directional change fittings you use directly increases the overall resistance to airflow.



4. Gradual directional changes are more efficient than sudden directional changes (i.e. use the largest corner radius possible when changing hose or pipe direction).
5. Each individual branch line should have a blast gate immediately after the branch to control suction from one machine to another.
6. The simpler the system, the more efficient and less costly it will be.

**Determine Required CFMs**

Since each machine produces a different amount of sawdust, the requirements for the minimum amount of CFM to move that sawdust is unique to the machine (for example, a planer produces more sawdust than a table saw). Knowing this required CFM is important to gauging which size of duct to use.

Refer to the figure below for a close estimation of the airflow each machine requires. Keep in mind that machines that generate the most sawdust should be placed closest to the dust collector. If the machine has multiple dust ports, the total CFM required is the sum of all ports.

Machine Dust Port Size	Approximate Required CFM
2"	100
2.5"	150
3"	250
4"	400
5"	600
6"	850
7"	1200
8"	1600
9"	2000
10"	2500

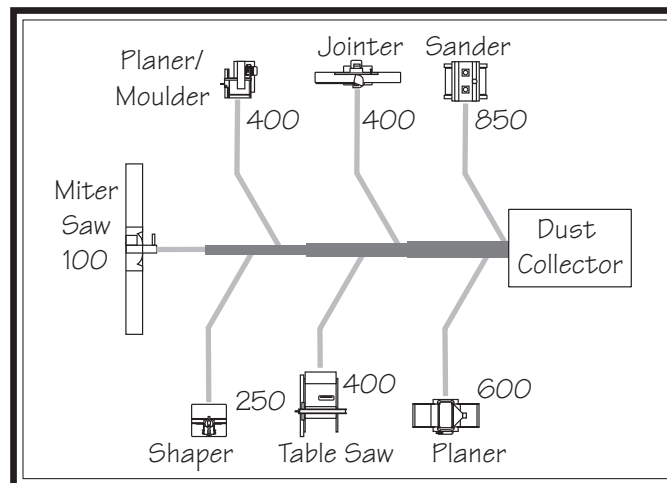
**Figure 38. Approximate required air flow for machine, based on dust port size.**

If the machine does not have a built-in dust port, use the following table to determine which size of dust port to install.

Machine	Average Dust Port Size
Table Saw	4"
Miter/Radial-Arm Saw	2"
Jointer (6" and smaller)	4"
Jointer (8"-12")	5"
Thickness Planer (13" and smaller)	4"
Thickness Planer (14"-20")	6"
Shaper	4"
Router (mounted to table)	2"
Bandsaw	4"
Lathe	4"
Disc Sander (12" and smaller)	2"
Disc Sander (13-18")	4"
Belt Sander (6" and smaller)	2"
Belt Sander (7"-9")	3"
Edge Sander (6" x 80" and smaller)	4"
Edge Sander (6" x 80" and larger)	5"
Drum Sander (24" and smaller)	2 x 4"
Drum Sander (24" and larger)	4 x 4"
Widebelt Sander (18" and smaller)	5"
Widebelt Sander (24"-37" single head)	2 x 6"
Widebelt Sander (24"-51" double head)	5 x 4"

**Figure 39. Dust port size and quantity per average machine.**

Write the required CFM for each machine on your sketch, as shown in the figure below.



**Figure 40. CFM requirements labeled for each machine.**

### Determine Main Line Duct Size

The general rule of thumb for a main line duct is that the velocity of the airflow must not fall below 3500 FPM.

For small/medium sized shops, using the inlet size of the dust collector as the main line duct size will usually keep the air velocity above 3500 FPM and, depending on your system, will allow you to keep multiple branches open at one time.

Mark your drawing, as shown in the figure below, but using the inlet size for your dust collector as the main line.

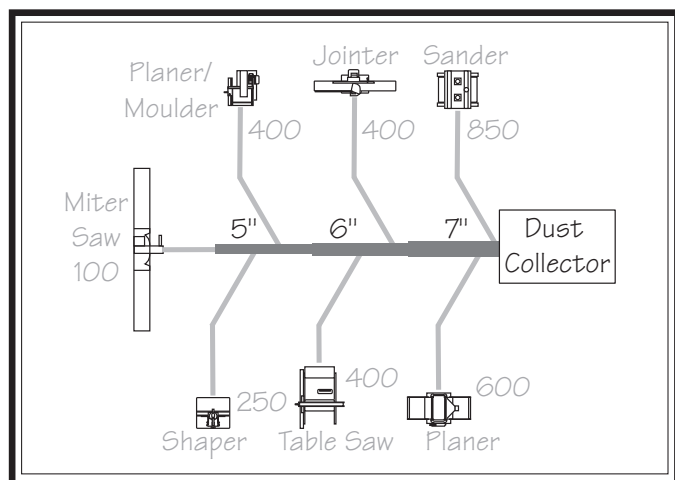


Figure 41. Main line size labeled on sketch.

### Determine Branch Line Duct Size

The general rule of thumb for a branch line duct is that the velocity of the airflow must not fall below 4000 FPM.

For small/medium sized shops, using the dust port size from the machine as the branch line duct size will achieve the correct velocity in most applications. However, if the dust port on the machine is smaller than 4", make the branch line 4" and neck the line down right before the dust port.

**Note:** *Systems with powerful dust collectors work better if multiple blast gates are left open. This also allows you to run two machines at once. Experiment with different combinations of blast gates open / closed to find the best results for your system.*

Write your determined branch line sizes on your drawing, as shown in the following figure.

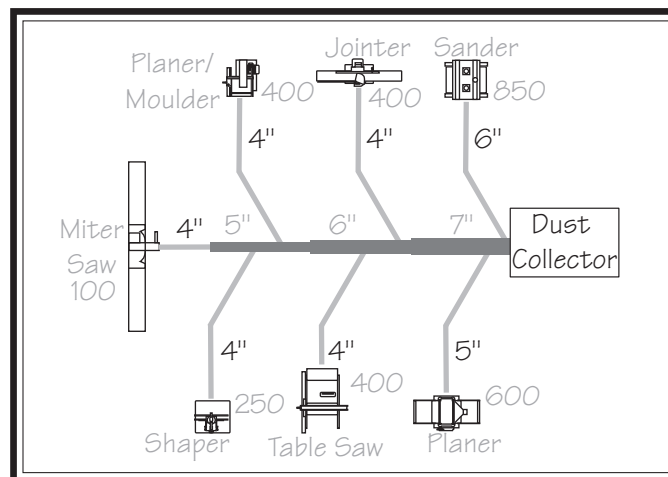


Figure 42. Branch line duct sizes labeled.

If two machines will connect to the same branch line and both will operate at the same time, then add the required CFM for each machine together and find the closest total CFM in the table below to determine the correct branch size.

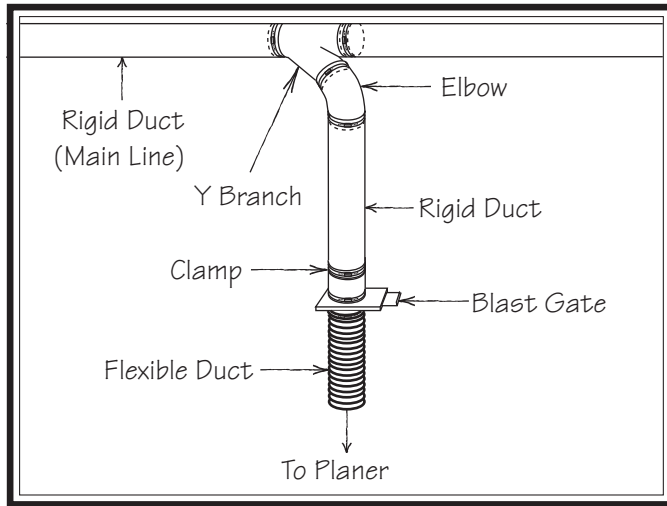
If both machines will never run at the same time, reference the machine with the biggest dust port in the table below and add blast gates after the Y-branch to open/close the line to each machine.

Total CFM	Branch Line Size
400	4"
500	4"
600	5"
700	5"
800	6"
900	6"
1000	6"

Figure 43. Sizing chart for multiple machines on the same branch line.

## Planning Drop Downs

Plan the drop downs for each machine, using blast gates wherever possible to control airflow.



**Figure 44. Drop-down setup.**

## Calculating Duct Resistance

Adding duct work, elbows, branches and any other components to a duct line increases airflow resistance (static pressure loss). This resistance can be minimized by using rigid (smooth) duct and gradual curves, as opposed to flexible duct and 90° elbows.

To help you think about this resistance, imagine riding a bicycle in a tunnel that is an exact replica of your duct work. If the inside of the tunnel is very bumpy (flexible duct) and has a lot of sharp turns (90° elbows), it will take a lot more effort to travel from one end to the other.

The purpose of calculating the resistance is to determine if it is low enough from the machine to the dust collector to meet the given CFM requirement for the machine. Use the following tables to calculate the resistance of duct work.

Duct Dia.	Approximate Static Pressure Loss Per Foot of Rigid Duct		Approximate Static Pressure Loss Per Foot of Flexible Duct	
	Main Lines at 3500 FPM	Branch Lines at 4000 FPM	Main Lines at 3500 FPM	Branch Lines at 4000 FPM
2"	0.091	0.122	0.35	0.453
2.5"	0.08	0.107	0.306	0.397
3"	0.071	0.094	0.271	0.352
4"	0.057	0.075	0.215	0.28
5"	0.046	0.059	0.172	0.225
6"	0.037	0.047	0.136	0.18
7"	0.029	0.036	0.106	0.141
8"	0.023	0.027	0.08	0.108
9"	0.017	0.019	0.057	0.079

Fitting Dia.	90° Elbow	45° Elbow	45° Wye(Y)	90° Wye(Y)
3"	0.47	0.235	0.282	0.188
4"	0.45	0.225	0.375	0.225
5"	0.531	0.266	0.354	0.236
6"	0.564	0.282	0.329	0.235
7"	0.468	0.234	0.324	0.216
8"	0.405	0.203	0.297	0.189

**Figure 45. Static pressure loss charts.**

In most small/medium shops it is only necessary to calculate the line with the longest duct length or the most fittings (operating under the assumption that if the line with the highest resistance works, the others will be fine).

### To calculate the static pressure of any given line in the system, follow these steps:

1. Make a list of each size duct in the line, including the length, and multiply those numbers by the static pressure value given in the previous table.
2. List each type of elbow or branch and multiply the quantity (if more than one) by the static pressure loss given in the previous table.

3. Add the additional factors from the following table to your list.

Additional Factors	Static Pressure
Seasoned (well used) Dust Collection Filter	1"
Entry Loss at Large Machine Hood	2"

**Figure 46. Additional factors affecting static pressure.**

4. Total your list as shown in the example below to come up with your overall static pressure loss number for that line.

**Note:** Always account for a seasoned filter, so you don't end up with a system that only works right when the filter is clean.

<b>Main Line</b>	
6" Rigid Duct (0.037) at 20'	0.740
<b>Branch Line</b>	
4" Rigid Duct (0.075) at 10'	0.750
4" Flexible Duct (0.28) at 5'	1.400
<b>Elbows/Branches</b>	
6" 45° Y-Branch	0.329
4" 45° Elbow	0.225
<b>Additional Factors</b>	
Seasoned Filter	1.000
<b>Total Static Pressure Loss</b>	<b>4.444</b>

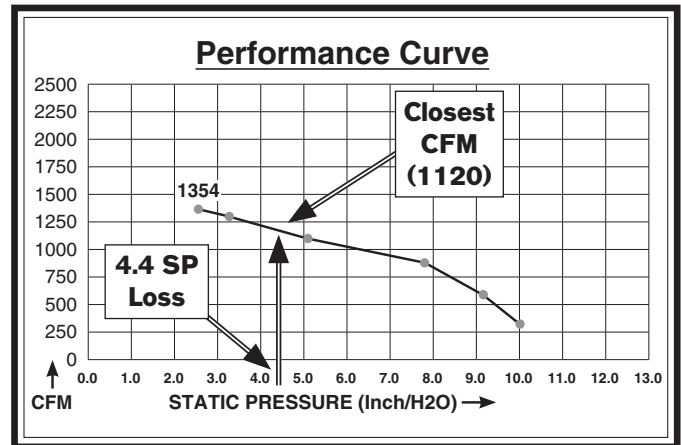
**Figure 47. Totaling static pressure numbers.**

**Note:** When calculating static pressure loss to determine if multiple lines can be left open at the same time, only include the main line numbers once.

5. Compare the total static pressure loss for that line to the closest CFM given on the performance curve for your dust collector.

**Example:** A typical Data Sheet Performance Curve is illustrated in the figure below. Find the total static pressure loss on the Static Pressure axis (4.4 in the current example), then refer to the closest value on the CFM axis—approximately 1120 CFM.

The 1120 CFM for the static pressure loss of the line connected to the router is well above the 220 CFM requirement of that machine.



**Figure 48. CFM for static pressure loss of line connected to a dust collector and router.**

— If the CFM for your static pressure loss is above the requirement of the machine connected to the end of that branch line, then dust collection will most likely be successful. Congratulations! You've just designed your own dust system. Refer to the **Accessories** section of this manual to start buying the components necessary to make your system a reality.

— If the CFM for your static pressure loss is below the requirement of the machine, then that line will not effectively collect the dust. You must then modify some of the factors in that line to reduce the static pressure loss. Some of the ways to do this include 1) installing larger duct, 2) reducing amount of flexible duct used, 3) increasing machine dust port size, 4) moving machine closer to dust collector to eliminate duct length, and 5) reducing 90° elbows or replacing them with 45° elbows.

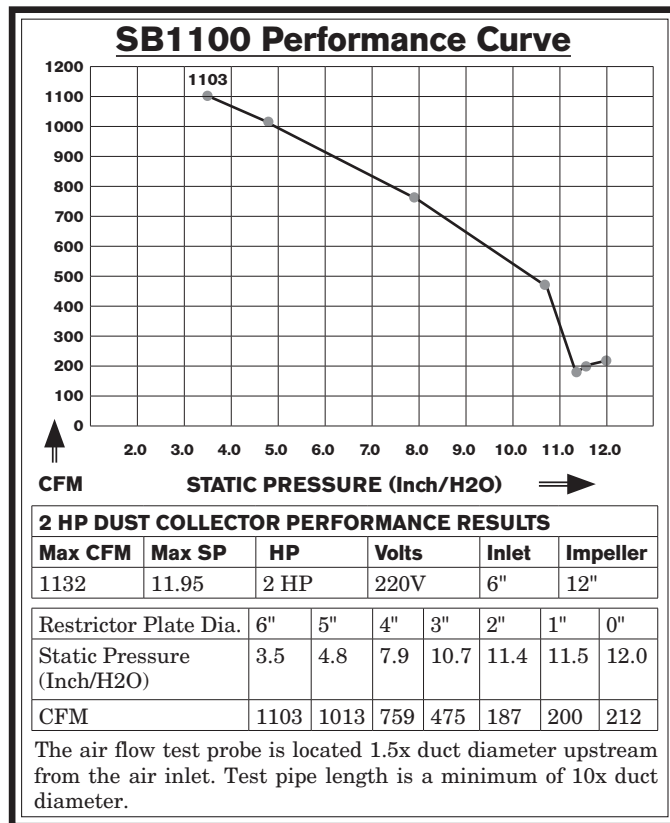


Figure 49. SB1100 performance data.

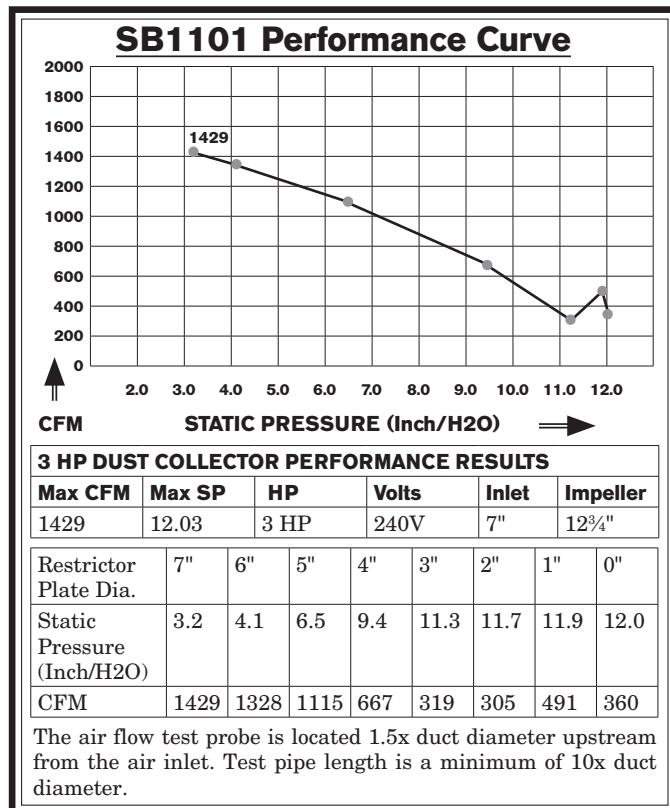


Figure 50. SB1101 performance data.

## Example Materials List

After the system is designed, create a materials list of all the items you will need to build your dust collection system. This will make it easy when it comes time to purchase the materials.

Below is an example of some items that might be needed.

Description	Model	Quantity
6" Rigid Duct at 20'	G7364	4
4" Rigid Duct at 10'	G6162	2
4" Flex Hose at 5'	H7215	6
6" 45° Y-Branch	G7353	6
4" 45° Elbow	G6167	6

Figure 51. Example materials list.



## System Grounding

Since plastic hose is abundant, relatively inexpensive, easily assembled and air tight, it is a very popular material for conveying dust from woodworking machines to the dust collector.

We recommend only using short lengths of flexible hose (flex-hose) to connect the woodworking machine to the dust collector. However, plastic flex-hose and plastic duct are an insulator, and dust particles moving against the walls of the plastic duct create a static electrical buildup. This charge will build until it discharges to a ground.

If a grounding medium is not available to prevent static electrical buildup, the electrical charge will arc to the nearest grounded source. This electrical discharge may cause an explosion and subsequent fire inside the system.

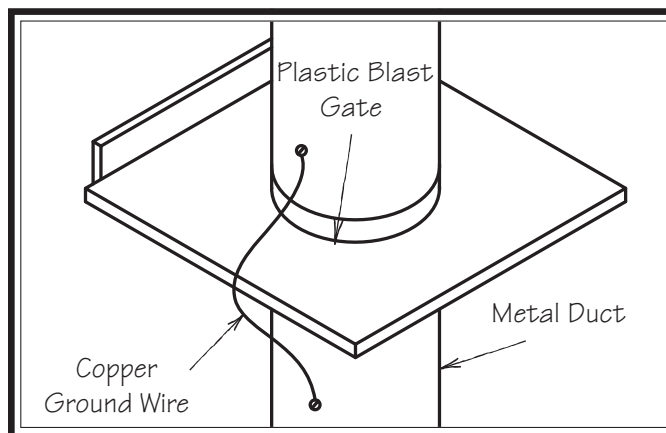
To protect against static electrical buildup inside a non-conducting duct, a bare copper wire should be placed inside the duct along its length and grounded to the dust collector. You must also confirm that the dust collector is continuously grounded through the electrical circuit to the electric service panel.

If you connect the dust collector to more than one machine by way of a non-conducting branching duct system and blast gates, the system must still be grounded as mentioned above. We recommend inserting a continuous bare copper ground wire inside the entire duct system and attaching the wire to each grounded woodworking machine and dust collector.



Be sure that you extend the bare copper wire down all branches of the system. Do not forget to connect the wires to each other with wire nuts when two branches meet at a “Y” or “T” connection.

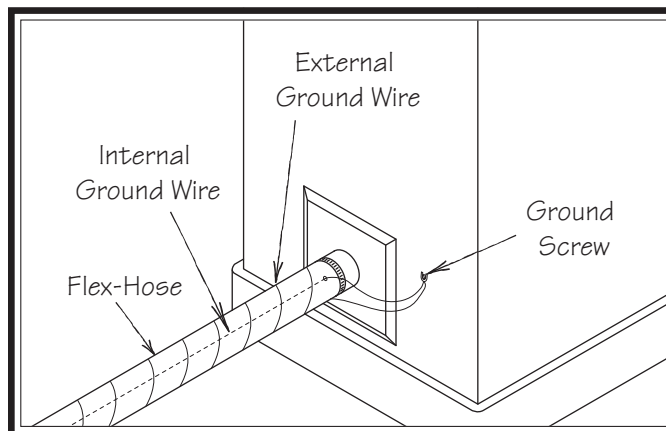
Ensure that the entire system is grounded. If using plastic blast gates to direct air flow, the grounding wire must be jumped (see the figure below) around the blast gate without interruption to the grounding system.



**Figure 52. Ground jumper wire when using plastic blast gates and metal duct.**

We also recommend wrapping the outside of all plastic ducts with bare copper wire to ground the outside of the system against static electrical buildup. Wire connections at Y's and T's should be made with wire nuts.

Attach the bare ground wire to each stationary woodworking machine and attach to the dust collector frame with a ground screw as shown in the figure below. Ensure that each machine is continuously grounded to the grounding terminal in your electric service panel.

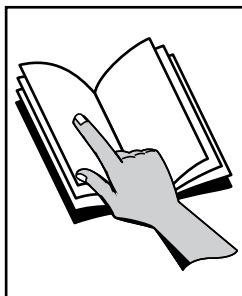


**Figure 53. Flex-hose grounded to machine.**

## Operation Overview

The purpose of this overview is to provide the novice machine operator with a basic understanding of how the machine is used during operation, so they can more easily understand the controls discussed later in this manual.

**Note:** Due to the generic nature of this overview, it is not intended to be an instructional guide for performing actual machine operations. To learn more about specific operations and machining techniques, seek training from people experienced with this type of machine, and do additional research outside of this manual by reading "how-to" books, trade magazines, or websites.



### **!WARNING**

To reduce the risk of serious injury when using this machine, read and understand this entire manual before beginning any operations.



### **!WARNING**

During operation, small wood chips and dust may become airborne, leading to serious eye injury or lung damage. Wear safety glasses and a respirator to reduce this risk.

This single-stage dust collector pulls wood dust past the impeller, which is then caught by a canister filter and deposited in the plastic collection bag below. The spunbond polyester filter catches 99.9 percent of particles 2 - 5 micron in size, and is pleated to provide maximum surface area for efficient air flow.

To maintain CFM after heavy use, the automatic filter brush knocks caked-on dust into the collection bag when the machine is turned **OFF**.

**To complete a typical operation, the operator does the following:**

1. Locks dust collector swivel casters.
2. Closes blast gates to direct vacuum pressure to desired machine.
3. Turns woodworking machine **ON**.
4. Turns dust collector **ON**.
5. Performs woodworking operation.
6. Turns woodworking machine **OFF**.
7. Turns dust collector **OFF**.

## Accessories

### ⚠ WARNING

Installing unapproved accessories may cause machine to malfunction, resulting in serious personal injury or machine damage. To reduce this risk, only install accessories recommended by South Bend or Grizzly.

### NOTICE

Refer to Grizzly's website or latest catalog for additional recommended accessories.

This section includes the most common accessories available for your machine, which are available through our exclusive dealer, Grizzly Industrial, Inc., at [grizzly.com](http://grizzly.com).

- D4206—Clear Flexible Hose 4" x 10'**
- D4256—45° Elbow 4"**
- D4216—Black Flexible Hose 4" x 10'**
- W1034—Heavy-Duty Clear Flex Hose 4" x 10'**
- D2107—Hose Hanger 4 1/4"**
- W1015—Y-Fitting 4" x 4" x 4"**
- W1017—90° Elbow 4"**
- W1019—Hose Coupler (Splice) 4"**
- W1317—Wire Hose Clamp 4"**
- W1007—Plastic Blast Gate 4"**
- W1053—Anti-Static Grounding Kit**



Figure 54. 4" dust-collection accessories.

- G6177—4" Metal Blast Gate**
- G7340—5" Metal Blast Gate**
- G7358—6" Metal Blast Gate**
- H5234—7" Metal Blast Gate**
- H5249—8" Metal Blast Gate**

Control air flow and resistance between machines. These industrial blast gates can take the abuse of thousands of open and close cycles. Made specifically for production shops. These metal industrial dust collection fittings are simply the best you can find.

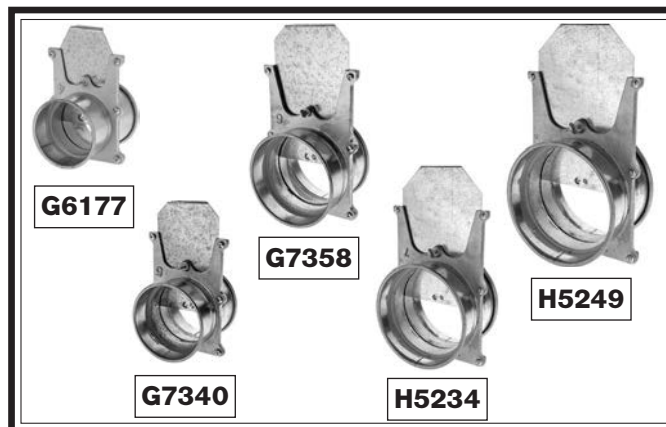


Figure 55. Metal blast gate assortment.

### T27422—Viewing Spool 8"

This viewing spool is a section of acrylic glass with QF ends so you can keep an eye on your material flow. Makes it a cinch to check for slow-downs or debris! Ends are 22 gauge, 8" opening. Total length 12.5".



Figure 56. T27422 Viewing Spool.

order online at [www.grizzly.com](http://www.grizzly.com) or call 1-800-523-4777

- H7428—8" Industrial Dust Collection Machine Adapter**
- H5228—8" Industrial Dust Collection Pipe Clamp**
- H5229—8" Industrial Dust Collection Adjustable Nipple**
- H5250—8" Industrial Dust Collection Pipe Hanger**
- T26510—8" Industrial Dust Collection Clamp Hanger**
- T27054—8" Quick-Fit O-Ring, 12-Pk.**
- T28548—8" x 6" x 6" Industrial Dust Collection Standard Branch**

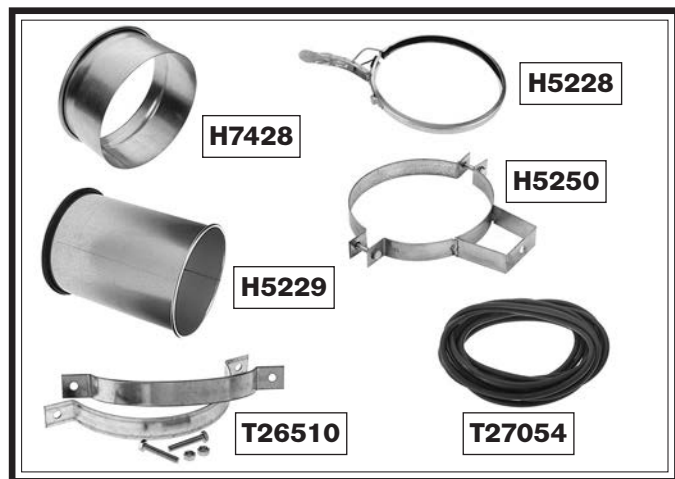


Figure 57. 8" dust-collection accessories.

- H7465—8" x 10' Dust Hose**
- H7463—7" x 10' Dust Hose**
- W1036—6" x 10' Dust Hose**

Spiral-wire-reinforced clear hose allows easy inspection for locating potential clogs in your duct system. Uses RH fittings. Available in additional diameters and lengths.

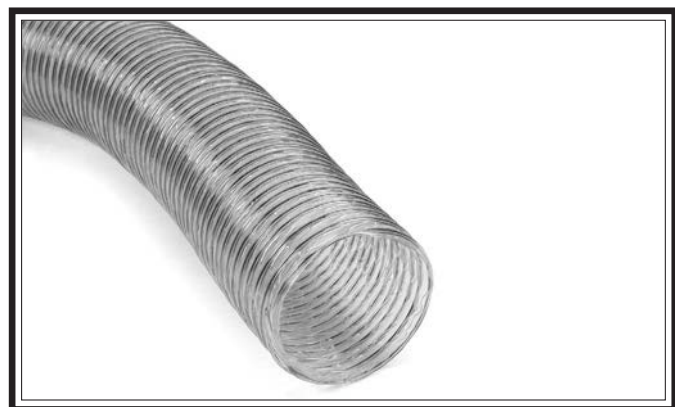


Figure 58. Flexible clear dust hose.

- H7217—6" x 5' Rigid Flex Hose**
- H7218—7" x 5' Rigid Flex Hose**
- H7219—8" x 5' Rigid Flex Hose**

These Rigid Flex Hoses with rolled collars provide just enough flexibility to make difficult connections while still keeping the inside wall smooth.

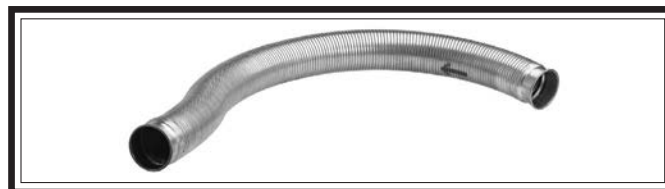


Figure 59. Rigid flex hose.

**W1039—Universal Adapter**

This adapter provides a multitude of reducing options. Simply cut off unneeded steps. Outside diameter sizes include 1", 2", 2½", 3", 4", 5", and 6". Wall thickness is ½".

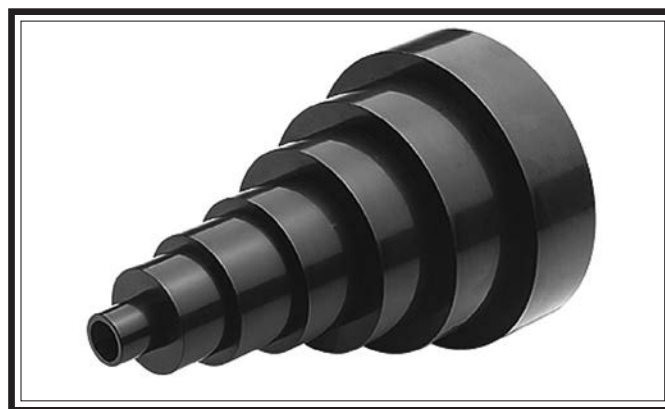


Figure 60. W1039 Universal Adapter.

- G6162—4" x 5' Straight Metal Pipe**
- G7346—5" x 5' Straight Metal Pipe**
- G7364—6" x 5' Straight Metal Pipe**



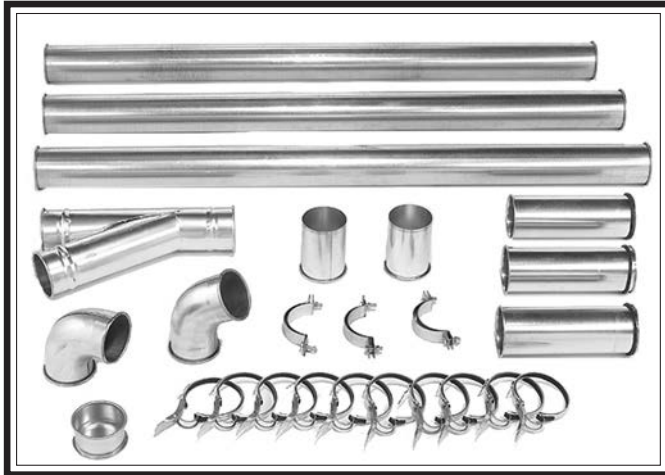
Figure 61. Straight metal pipe.

**order online at [www.grizzly.com](http://www.grizzly.com) or call 1-800-523-4777**



**H5293—4" Metal Duct Starter Kit****H5295—5" Metal Duct Starter Kit****H5297—6" Metal Duct Starter Kit**

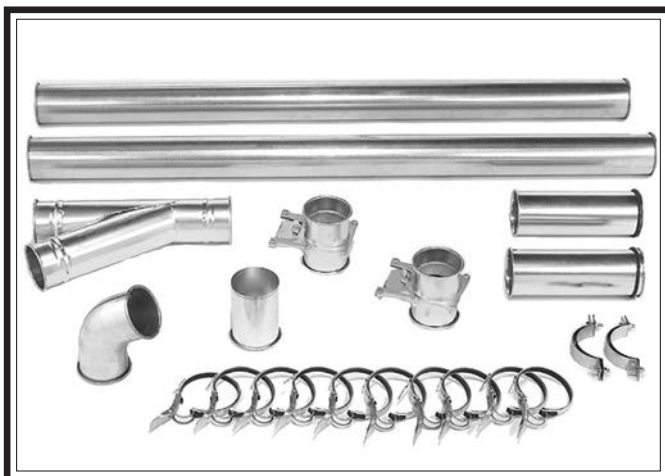
Save over 20% with this great starter kit. Includes: (2) machine adapters, (10) pipe clamps, (3) 5' straight pipes, (1) branch, (3) pipe hangers, (1) end cap, (3) adjustable nipples, (1) 90° elbow, and (1) 60° elbow.



**Figure 62. Metal Duct Starter Kit.**

**H5294—4" Metal Duct Machine Addition Kit****H5296—5" Metal Duct Machine Addition Kit****H5298—6" Metal Duct Machine Addition Kit**

Save over 20% with this great machine addition kit. Includes: (2) blast gates, (1) machine adapter, (10) pipe clamps, (2) pipe hangers, (2) 5' straight pipes, (2) adjustable nipples, (1) branch, and (1) 60° elbow.



**Figure 63. Metal Duct Machine Addition Kit.**

**SB1487—Replacement Canister Filter**

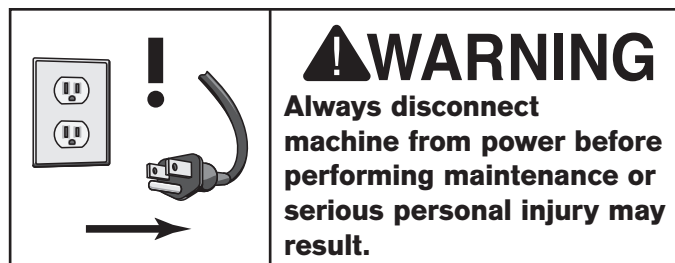
**Figure 64. Replacement canister filter.**

**T20543—Plastic Collection Bag 19.75" x 31"**

**Figure 65. Replacement collection bags.**

**order online at [www.grizzly.com](http://www.grizzly.com) or call 1-800-523-4777**





## Maintenance Schedule

For optimum performance from your machine, follow this maintenance schedule and refer to any specific instructions given in this section.

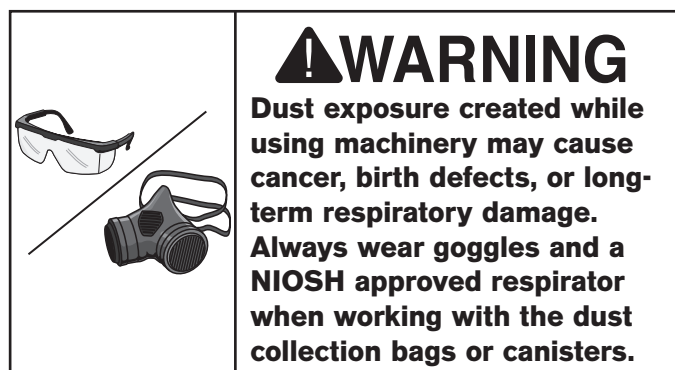
### Ongoing

To minimize your risk of injury and maintain proper machine operation, shut down the machine immediately if you ever observe any of the items below, and fix the problem before continuing operations:

- Loose mounting bolts.
- Damaged filter canister, cleaning paddle components, or collection bags.
- Worn or damaged wires.
- Suction leaks.
- Any other unsafe condition.

### Monthly Check

- Clean/vacuum dust buildup off machine body and motor.



## Cleaning Canister Filter

This dust collector uses an automatic filter brush to remove dust buildup and debris from the filter pleats. The system will turn **ON** for approximately 90 seconds after the machine is turned **OFF** to clean the canister filter and knock dust cake into the filter bag.

If operating pressure on pressure gauge drops below 200mmAq, remove canister filter and gently knock dust from pleats (refer to **Removing/Replacing Canister Filter** on **Page 37**). If operating pressure reaches 150mmAq and cleaning does not improve performance, replace the filter.

**IMPORTANT:** *DO NOT use water or high pressure to clean canister filter. Doing so will damage the filter and reduce filtration.*

Dispose of the filter collection bag when dust fills it about  $\frac{1}{2}$  full (see **Removing/Replacing Filter Collection Bag** on **Page 37**).

**IMPORTANT:** *To contain wood dust and minimize risk of exposure, firmly tie bag closed.*

## Removing/Replacing Collection Bag

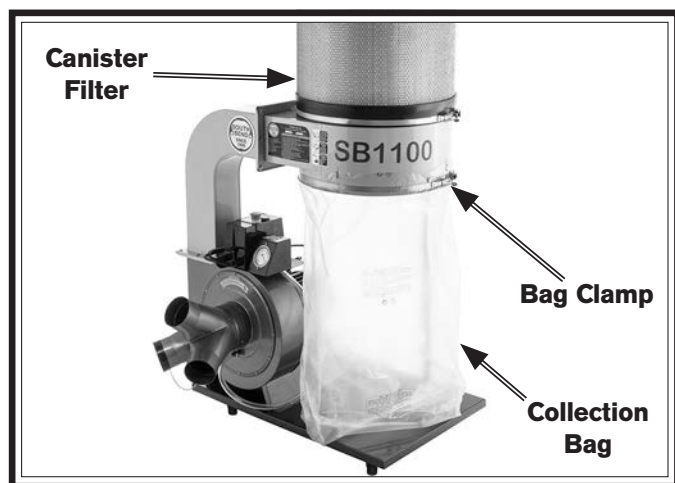
Remove and replace the collection bag when it is about 1/2 full.

Items Needed	Qty
T20543 Filter Bag .....	1

### To remove & replace filter bag or bags:

1. DISCONNECT MACHINE FROM POWER!
2. Release bag clamp around bottom of canister filter, then remove filter bag (see **Figure 66**).

**IMPORTANT:** *To contain wood dust and minimize risk of exposure, tie bag closed before disposal.*



**Figure 66. Filter bag components.**

3. Attach new filter bag around bottom of canister filter and secure with clamp.

## Removing/Replacing Canister Filter

If the canister filter is clogged or dirty and cleaning does not improve dust-collection performance, the canister filter must be replaced.

Items Needed	Qty
An Assistant .....	1
Safety Glasses (Per Person).....	1
Phillips Screwdriver #2 .....	1
Wrench or Socket, 10mm.....	1
SB1487 Replacement Canister Filter ..	As Needed

### To remove & replace canister filter:

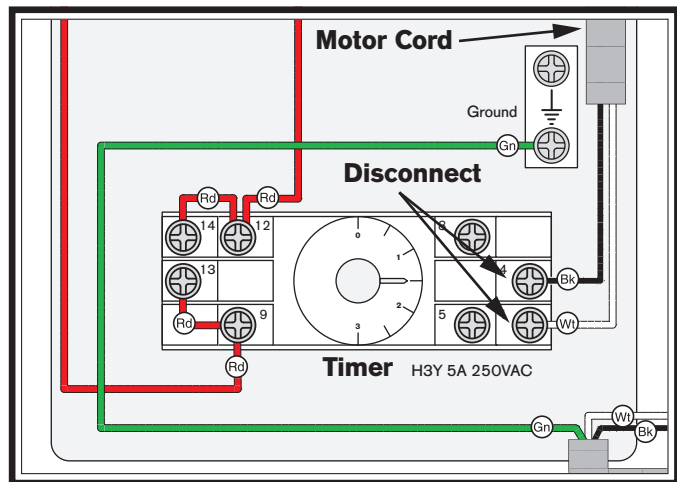
1. DISCONNECT MACHINE FROM POWER!
2. Remove front cover from switch box and loosen strain relief (see **Figure 67**).



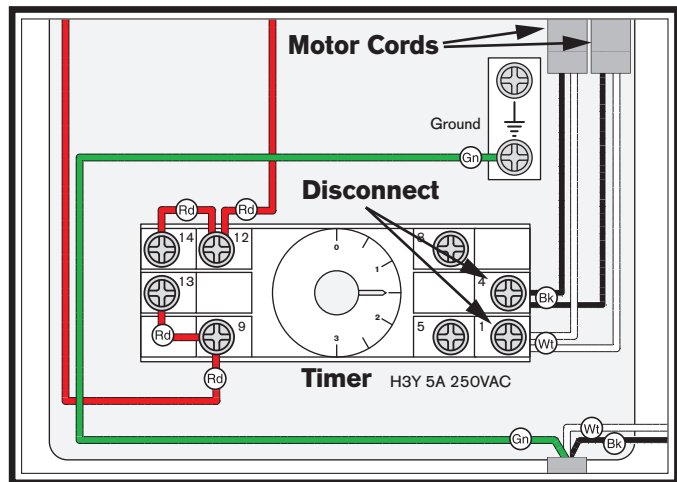
**Figure 67. Switch box front cover.**

3. Disconnect motor cord(s) from right terminals of timer inside switch box (see **Figures 68–69**).

**Note:** *Timer module may be pulled off terminal block if it is in the way.*



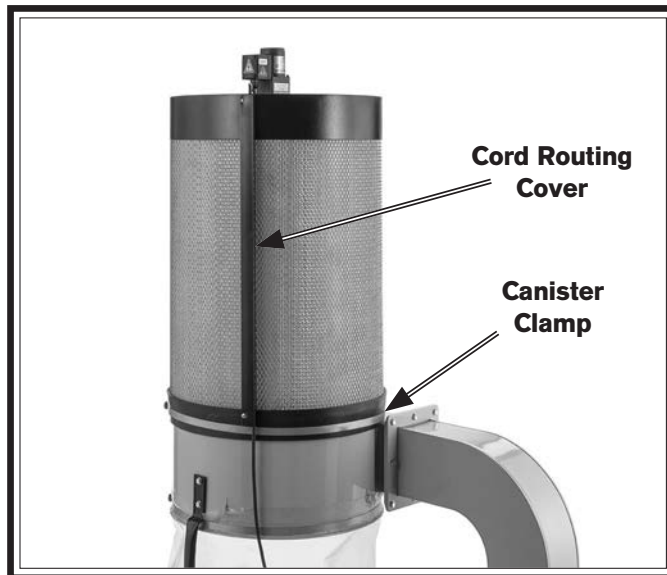
**Figure 68. SB1100 filter brush motor connection.**



**Figure 69. SB1101 filter brush motor connection.**

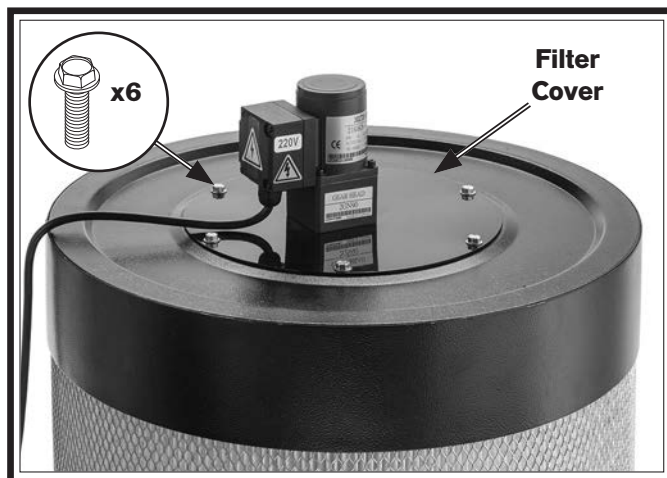
**Note:** *For full wiring diagrams, refer to SB1100 Wiring Diagram on **Page 45** and SB1101 Wiring Diagram on **Page 48**.*

4. Pull end of motor cord out of cord routing cover (see **Figure 70**).
5. Release canister clamp (see **Figure 70**).



**Figure 70. Canister filter components.**

6. While assistant holds collector in place, remove canister filter from collector.
7. Vacuum loose dust from collector.
8. Remove (6) flange bolts and filter cover assembly (see **Figure 71**).



**Figure 71. Filter cover.**

9. Loosen hex bolt and remove lower alignment arm from filter brush spindle (see **Figure 72**), then attach lower alignment arm to new canister filter.
10. Position filter cover assembly over new canister filter. Rotate lower alignment arm so "V" on upper alignment arm captures lower arm when mounting holes align (see **Figures 72–73**).

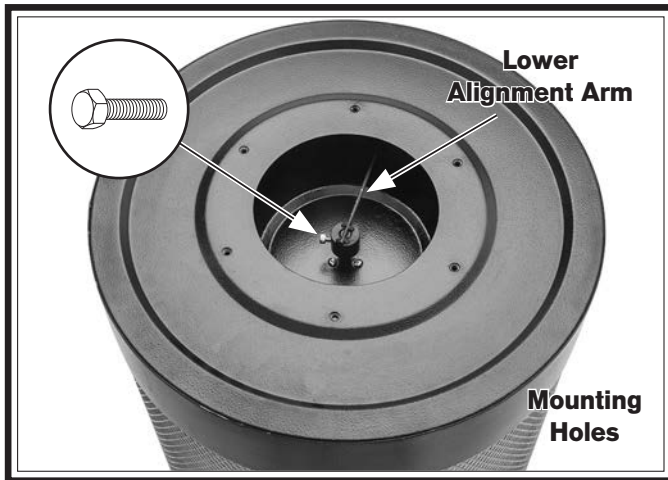


Figure 72. Top of canister and lower alignment arm.

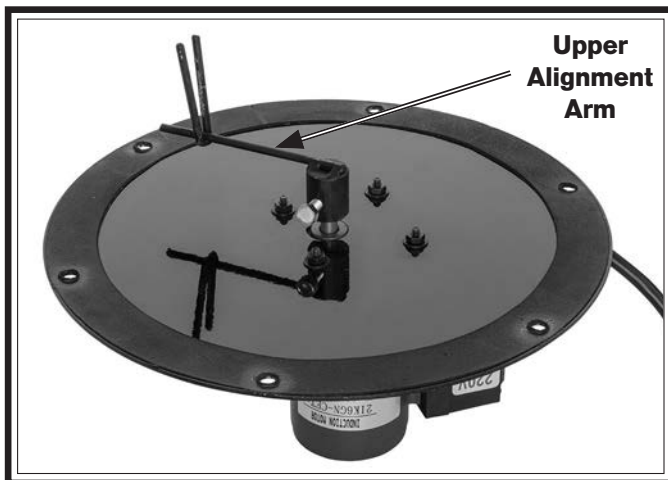


Figure 73. Underneath filter cover assembly.

11. Attach filter cover assembly to canister filter with flange bolts removed in **Step 8**.

12. Inspect foam tape on upper rim of collector and replace if worn or dirty. Trim excess tape so ends meet evenly without overhang or gap (see **Figure 74**).



Figure 74. Tape applied to top rim of collector.

13. Position canister clamp around base of canister filter, then place canister filter over collector (see **Figure 75**). Tighten clamp.

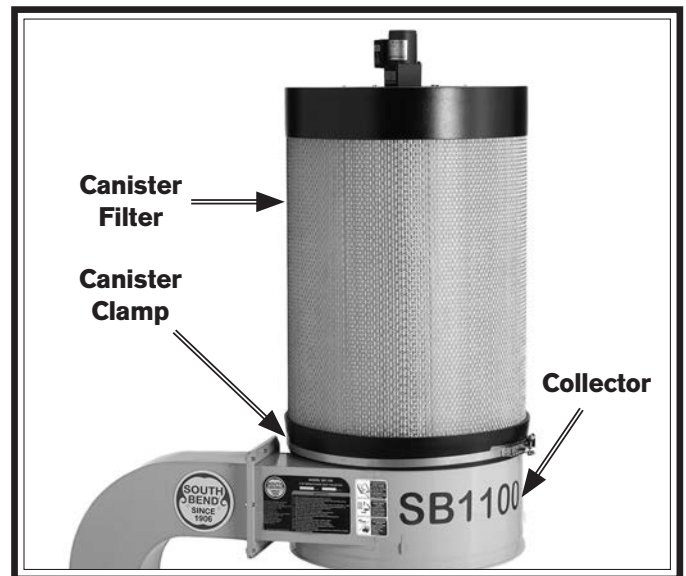
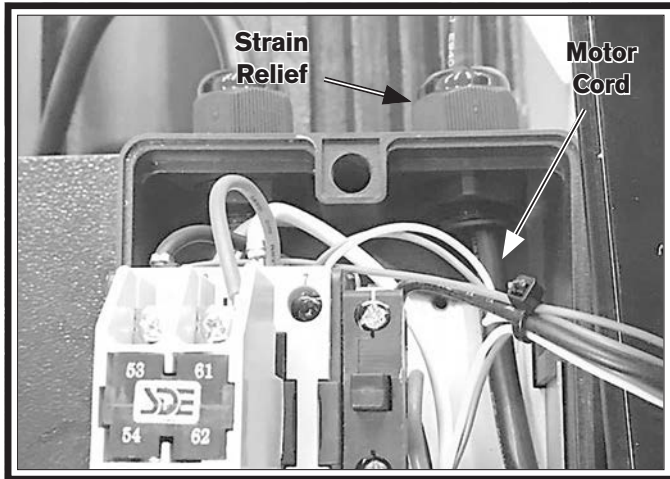


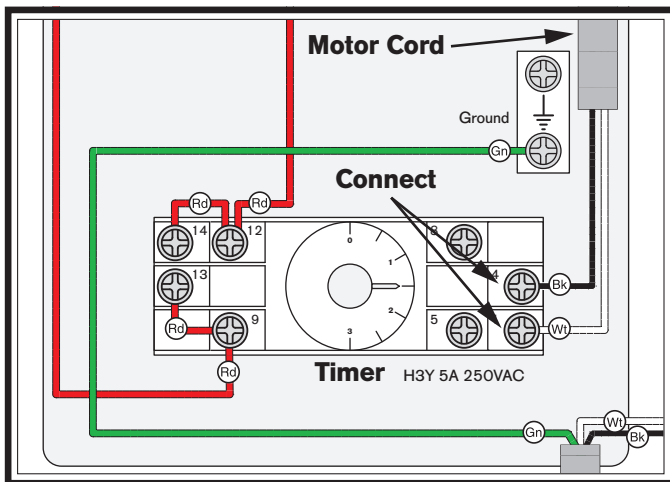
Figure 75. Canister filter secured to collector with canister clamp.

- Push filter brush motor power cord through cord routing cover and through strain relief at top of switch box (see **Figure 76**).

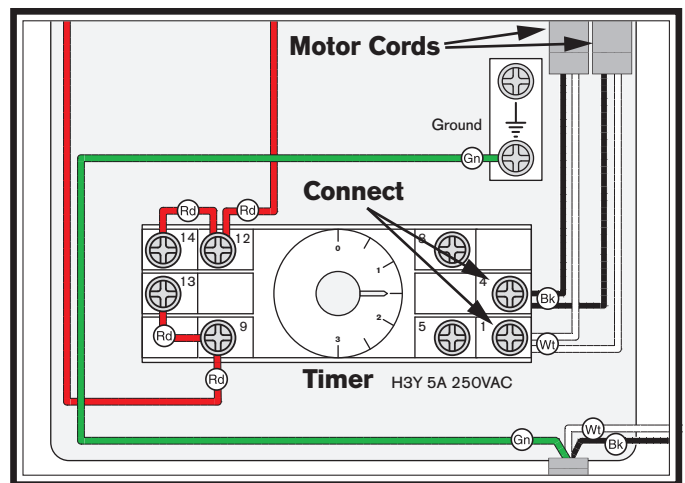


**Figure 76. Filter brush motor cord routed into switch box.**

- Connect motor terminal ends disconnected in **Step 3** to timer terminals (see **Figures 77-78**).



**Figure 77. SB1100 filter brush motor connection.**



**Figure 78. SB1101 filter brush motor connection.**

**Note:** For full wiring diagrams, refer to SB1100 Wiring Diagram on **Page 45** and SB1101 Wiring Diagram on **Page 48**.

- Tighten strain relief to secure motor cord(s) and attach switch box cover to switch box.



# Pairing Remote Control & Receiver

The Model SB1100 & SB1101 are equipped with a remote control receiver that can be programmed to operate up to 16 separate controllers.

## ⚠ WARNING

Avoid touching electrified parts inside receiver while performing procedure below! Touching electrified parts will result in personal injury including but not limited to severe burns, electrocution, or death. Use a wood dowel or other non-conducting item to push button on receiver.

### Items Needed

### Qty

Phillips Head Screwdriver #2.....	1
Wood Dowel.....	1

## Pairing Remote

1. Remove switch cover to get a clear view of remote receiver (see **Figure 79**).

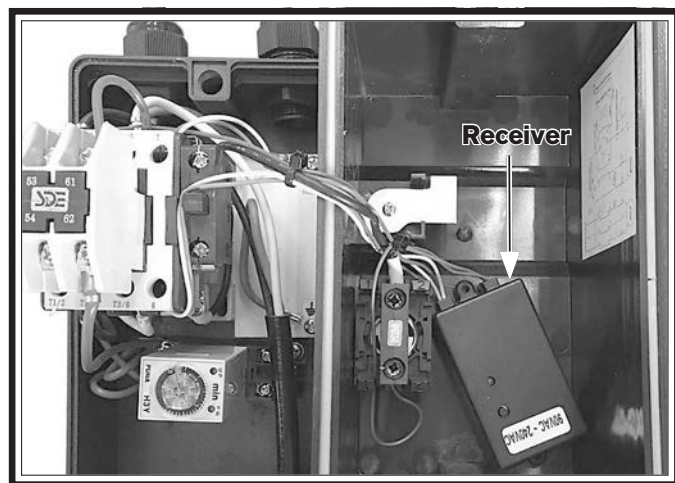


Figure 79. Location of receiver in switch box.

2. Press and hold green ON button on remote control (see **Figure 80**) until LED indicator illuminates on remote receiver (see **Figure 81**).
3. Press pairing button on receiver with a non-conducting tool, then release when LED indicator turns off (see **Figure 81**). Pairing is complete.



Figure 80. Remote control.

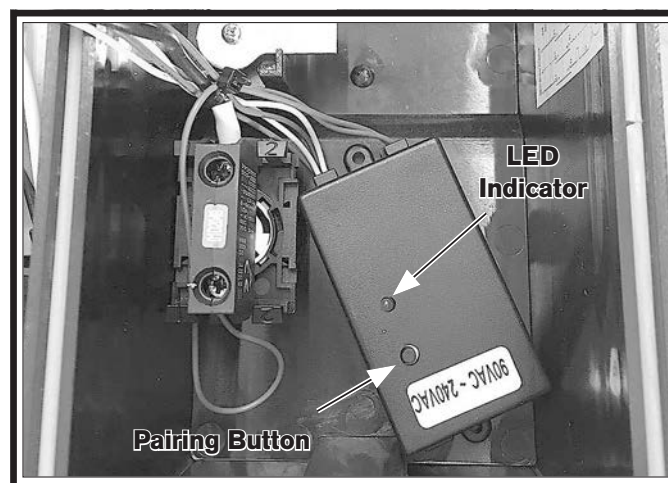


Figure 81. Remote receiver.

## Unpairing Remote

1. Remove switch cover to get a clear view of remote receiver (see **Figure 79**).
2. Press and hold green ON button on remote control for eight seconds, then wait for LED indicator to flash three times.

If you need replacement parts, or if you are unsure how to do any of the solutions given here, feel free to call us at (360) 734-1540.

Symptom	Possible Cause	Possible Solution
Machine does not start or a breaker trips immediately after startup.	<ol style="list-style-type: none"> <li>1. Dust collector not connected to ducting.</li> <li>2. E-Stop button depressed/at fault.</li> <li>3. Machine circuit breaker tripped.</li> <li>4. Incorrect power supply voltage or circuit size.</li> <li>5. Remote control not working.</li> <li>6. Remote receiver at fault.</li> <li>7. Power supply circuit breaker tripped or fuse blown.</li> <li>8. Motor wires connected incorrectly.</li> <li>9. Start capacitor at fault.</li> <li>10. Contactor not energized/at fault.</li> <li>11. Wiring broken, disconnected, or corroded.</li> <li>12. Power switch/circuit breaker at fault.</li> <li>13. Centrifugal switch adjustment/contact points at fault.</li> <li>14. Motor or motor bearings at fault.</li> </ol>	<ol style="list-style-type: none"> <li>1. Connect dust collector to ducting (<b>Page 23</b>).</li> <li>2. Rotate E-Stop button to reset. Replace if at fault.</li> <li>3. Reset circuit breaker on switch.</li> <li>4. Ensure correct power supply voltage and circuit size.</li> <li>5. Replace battery; stay in signal range.</li> <li>6. Inspect/replace if at fault.</li> <li>7. Ensure circuit is free of shorts. Reset circuit breaker or replace fuse.</li> <li>8. Correct motor wiring connections.</li> <li>9. Test/replace if at fault.</li> <li>10. Test all legs for power; replace if necessary.</li> <li>11. Fix broken wires or disconnected/corroded connections.</li> <li>12. Replace switch/circuit breaker.</li> <li>13. Adjust centrifugal switch/clean contact points. Replace either if at fault.</li> <li>14. Replace motor.</li> </ol>
Machine stalls or is underpowered.	<ol style="list-style-type: none"> <li>1. Dust collection ducting problem.</li> <li>2. Collection bags full.</li> <li>3. Canister filter clogged/at fault.</li> <li>4. Dust collector too far from machine or undersized for dust-collection system.</li> <li>5. Motor overheated, tripping machine circuit breaker.</li> <li>6. Run capacitor at fault.</li> <li>7. Extension cord too long.</li> <li>8. Contactor not energized/at fault.</li> <li>9. Centrifugal switch adjustment/contact points at fault.</li> <li>10. Motor or motor bearings at fault.</li> </ol>	<ol style="list-style-type: none"> <li>1. Clear blockages, seal leaks, use smooth wall duct, eliminate bends, close other branches.</li> <li>2. Replace collection bags.</li> <li>3. Clean canister filter (<b>Page 36</b>); replace canister filter after 1 year of regular use (<b>Page 37</b>).</li> <li>4. Move closer to machine/redesign ducting layout (<b>Page 23</b>)/upgrade dust collector.</li> <li>5. Clean motor/let cool, and reduce workload. Reset breaker.</li> <li>6. Test/repair/replace.</li> <li>7. Move machine closer to power supply; use shorter extension cord.</li> <li>8. Test all legs for power; repair/replace if at fault.</li> <li>9. Adjust centrifugal switch/clean contact points. Replace either if at fault.</li> <li>10. Replace motor.</li> </ol>
Machine has excessive vibration or noise.	<ol style="list-style-type: none"> <li>1. Motor or component loose.</li> <li>2. Motor mount loose/broken.</li> <li>3. Motor fan rubbing on fan cover.</li> <li>4. Centrifugal switch is at fault.</li> <li>5. Impeller damaged, unbalanced, or loose.</li> <li>6. Motor bearings at fault.</li> </ol>	<ol style="list-style-type: none"> <li>1. Inspect/replace damaged or missing bolts/nuts, and retighten with thread-locking fluid.</li> <li>2. Tighten/replace.</li> <li>3. Fix/replace fan cover; replace loose/damaged fan.</li> <li>4. Adjust/replace centrifugal switch if available.</li> <li>5. Inspect/tighten/replace.</li> <li>6. Test by rotating shaft; rotational grinding/loose shaft requires bearing replacement.</li> </ol>

Symptom	Possible Cause	Possible Solution
Filter brush motor does not start after machine is powered <b>OFF</b> .	<ol style="list-style-type: none"> <li>1. Motor connected incorrectly at switch box.</li> <li>2. Timer at fault.</li> <li>3. Filter brush motor at fault.</li> </ol>	<ol style="list-style-type: none"> <li>1. Correct motor wiring connections (<b>Page 37</b>).</li> <li>2. Inspect/replace if at fault.</li> <li>3. Replace motor.</li> </ol>
Loud, repetitious noise, or excessive vibration coming from dust collector (non-motor related).	<ol style="list-style-type: none"> <li>1. Dust collector not on a flat surface and wobbles/casters not locked.</li> <li>2. Impeller damaged and unbalanced.</li> <li>3. Impeller loose on the motor shaft.</li> </ol>	<ol style="list-style-type: none"> <li>1. Stabilize dust collector; lock casters.</li> <li>2. Disconnect dust collector from power; inspect impeller for dents, bends, or loose fins; replace impeller if damaged.</li> <li>3. Secure impeller; replace motor and impeller as a set if motor shaft and impeller hub are damaged.</li> </ol>
Dust collector does not adequately collect dust or chips; poor performance.	<ol style="list-style-type: none"> <li>1. Collection bag(s) full.</li> <li>2. Canister filter clogged/at fault.</li> <li>3. Ducting blocked/restricted.</li> <li>4. Dust collector too far away from point of suction; duct clamps not properly secured; too many sharp bends in ducting.</li> <li>5. Lumber is wet and dust is not flowing smoothly through ducting.</li> <li>6. Ducting has one or more leaks, or too many open ports.</li> <li>7. Not enough open branch lines at one time, causing velocity drop in main line.</li> <li>8. Ducting and ports are incorrectly sized.</li> <li>9. Machine dust-collection design inadequate.</li> <li>10. Dust collector undersized.</li> <li>11. Unused inlet adapter port(s) uncovered.</li> </ol>	<ol style="list-style-type: none"> <li>1. Empty collection bag(s) (<b>Page 37</b>).</li> <li>2. Clean canister filter (<b>Page 36</b>); replace canister filter (<b>Page 37</b>).</li> <li>3. Remove ducting from dust collector inlet and unblock restriction. A plumbing snake may be necessary.</li> <li>4. Relocate dust collector closer to point of suction; re-secure ducts; remove sharp bends (<b>Page 23</b>).</li> <li>5. Only process lumber with less than 20% moisture content.</li> <li>6. Seal/eliminate all ducting leaks; close dust ports for lines not being used (<b>Page 23</b>).</li> <li>7. Open 1 or 2 more blast gates to different branch lines to increase main line velocity.</li> <li>8. Install correctly sized ducts and fittings (<b>Page 23</b>).</li> <li>9. Use dust-collection hood on stand.</li> <li>10. Install larger dust collector.</li> <li>11. Cover unused inlet adapter port(s).</li> </ol>
Dust collector blows sawdust into the air.	<ol style="list-style-type: none"> <li>1. Duct clamps or filter collection bag not properly clamped and secured; ducting loose/damaged.</li> <li>2. Cylinder or funnel seals are loose or damaged.</li> </ol>	<ol style="list-style-type: none"> <li>1. Secure ducts and filter collection bag, making sure duct and bag clamp are tight; tighten/replace ducting.</li> <li>2. Tighten all mounting and sealing points; replace damaged seals/gaskets.</li> </ol>
Remote control does not operate dust collector.	<ol style="list-style-type: none"> <li>1. Emergency Stop button is pressed in.</li> <li>2. Machine is disconnected from power.</li> <li>3. Remote control battery is weak or dead.</li> <li>4. Wall or barrier disrupts radio frequency, or controller is too far away.</li> <li>5. Remote control not paired with receiver.</li> </ol>	<ol style="list-style-type: none"> <li>1. Rotate Emergency Stop button to reset.</li> <li>2. Verify machine is connected to power source.</li> <li>3. Replace battery.</li> <li>4. Move machine away from barrier; use remote within 50' of machine.</li> <li>5. Program receiver to accept remote control (<b>Page 41</b>).</li> </ol>

# Electrical Safety Instructions

These pages are accurate at the time of printing. In the constant effort to improve, however, we may make changes to the electrical systems of future machines. Study this section carefully. If you see differences between your machine and what is shown in this section, call Technical Support at (360) 734-1540 for assistance BEFORE making any changes to the wiring on your machine.

**Shock Hazard:** It is extremely dangerous to perform electrical or wiring tasks while the machine is connected to the power source. Touching electrified parts will result in personal injury including but not limited to severe burns, electrocution, or death. For your own safety, disconnect machine from the power source before servicing electrical components or performing any wiring tasks!

**Wire Connections:** All connections must be tight to prevent wires from loosening during machine operation. Double-check all wires disconnected or connected during any wiring task to ensure tight connections.

**Modifications:** Using aftermarket parts or modifying the wiring beyond what is shown in the diagram may lead to unpredictable results, including serious injury or fire.

**Motor Wiring:** The motor wiring shown in these diagrams is current at the time of printing, but it may not match your machine. Always use the wiring diagram inside the motor junction box.

**Circuit Requirements:** Connecting the machine to an improperly sized circuit will greatly increase the risk of fire. To minimize this risk, only connect the machine to a power circuit that meets the minimum requirements given in this manual.

**Capacitors/Inverters:** Some capacitors and power inverters store an electrical charge for up to 10 minutes after being disconnected from the power source. To reduce the risk of being shocked, wait at least this long before working on capacitors.

**Wire/Component Damage:** Damaged wires or components increase the risk of serious personal injury, fire, or machine damage. If you notice that any wires or components are damaged while performing a wiring task, replace those wires or components before completing the task.

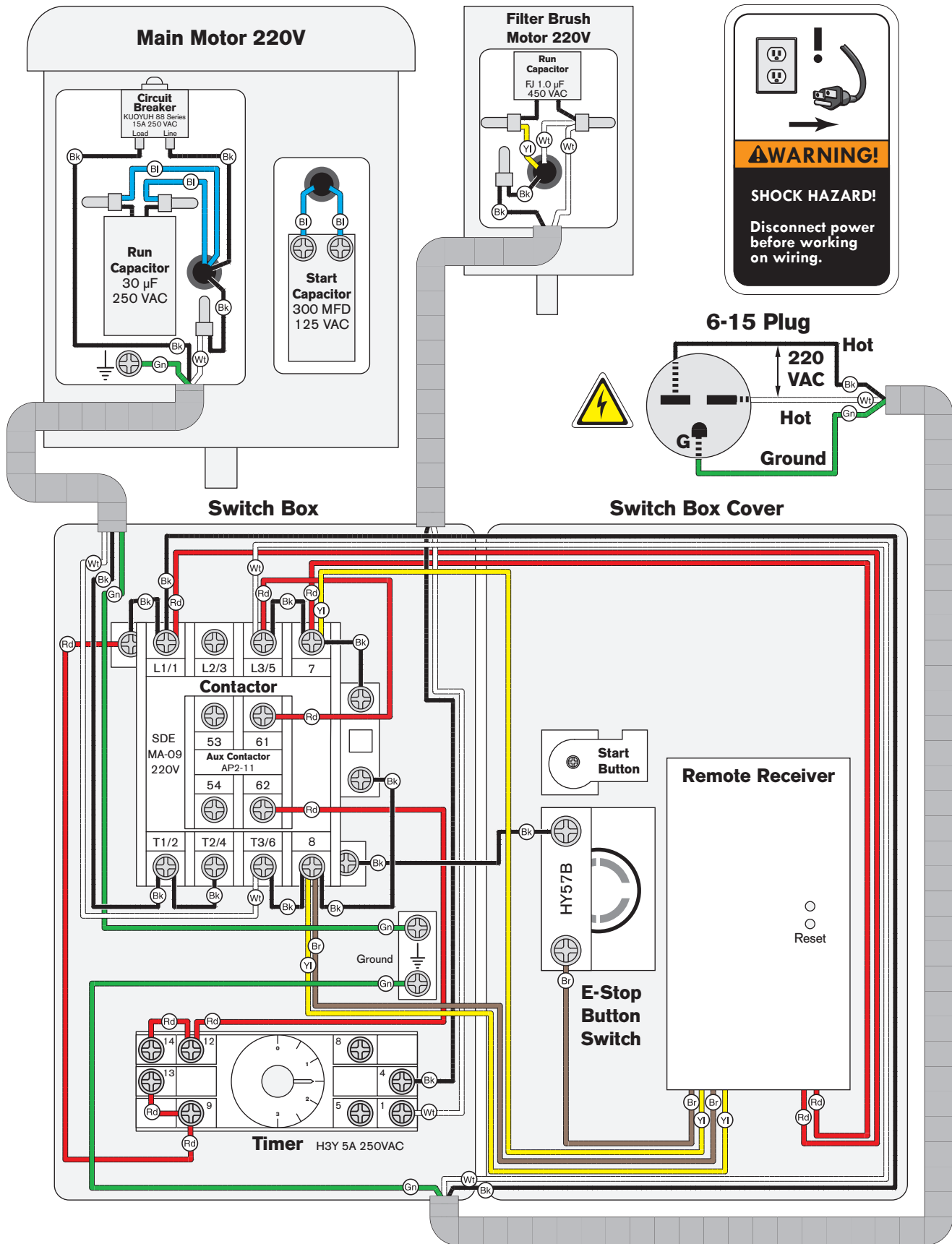
**Experiencing Difficulties:** If you are experiencing difficulties understanding the information included in this section, contact our Technical Support at (360) 734-1540.

## WIRING DIAGRAM COLOR KEY

BLACK — Bk	BLUE WHITE — Bw	RED — Rd	PINK — Pk	WHITE — Wt
BLUE — Bl	GREEN — Gn	LIGHT BLUE — Lb	PURPLE — Pu	YELLOW GREEN — Yg
BROWN — Br	GRAY — Gy	ORANGE — Or	TUR-QUIOSE — Tu	YELLOW — Yl

**NOTICE:** The photos and diagrams included in this section are best viewed in color. You can see them in color at [www.southbendtools.com](http://www.southbendtools.com).

# SB1100 Wiring Diagram





# SB1100 Electrical Component Pictures

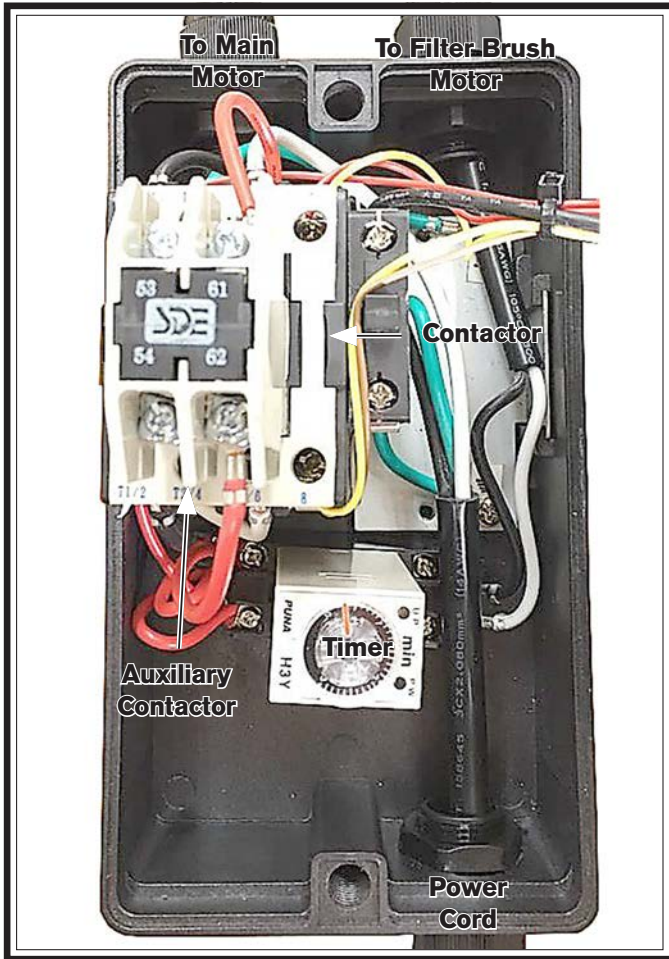


Figure 82. SB1100 switch box interior.

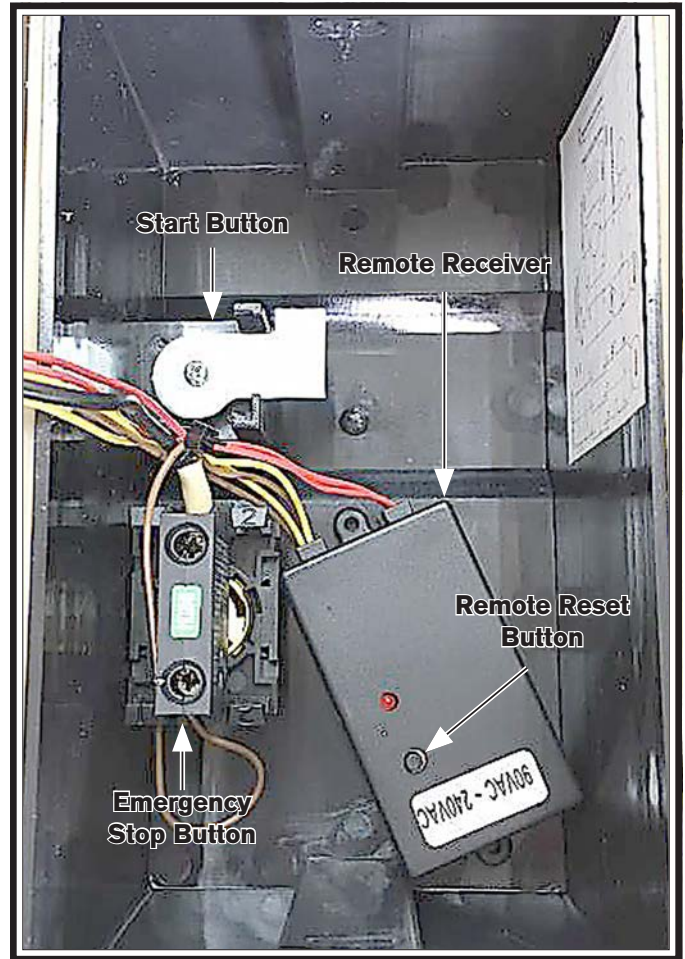


Figure 83. SB1100 switch box cover.

# SB1100 Electrical Component Pictures (Cont.)



Figure 84. SB1100 filter brush motor junction box.

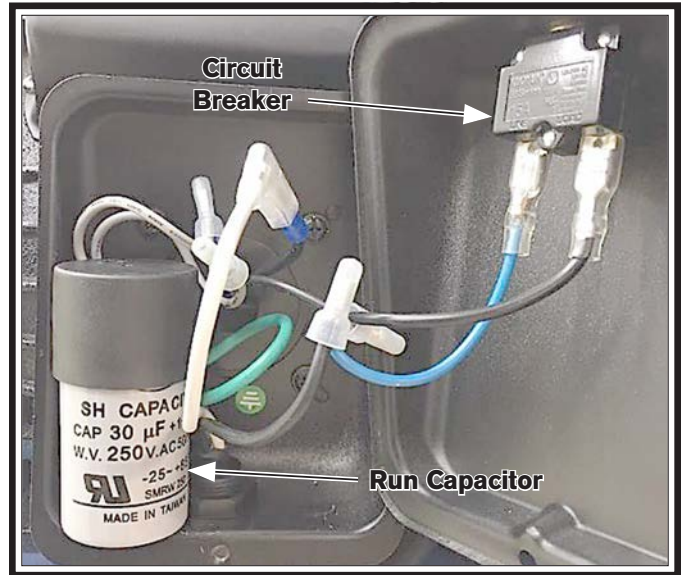


Figure 86. SB1100 main motor junction box.

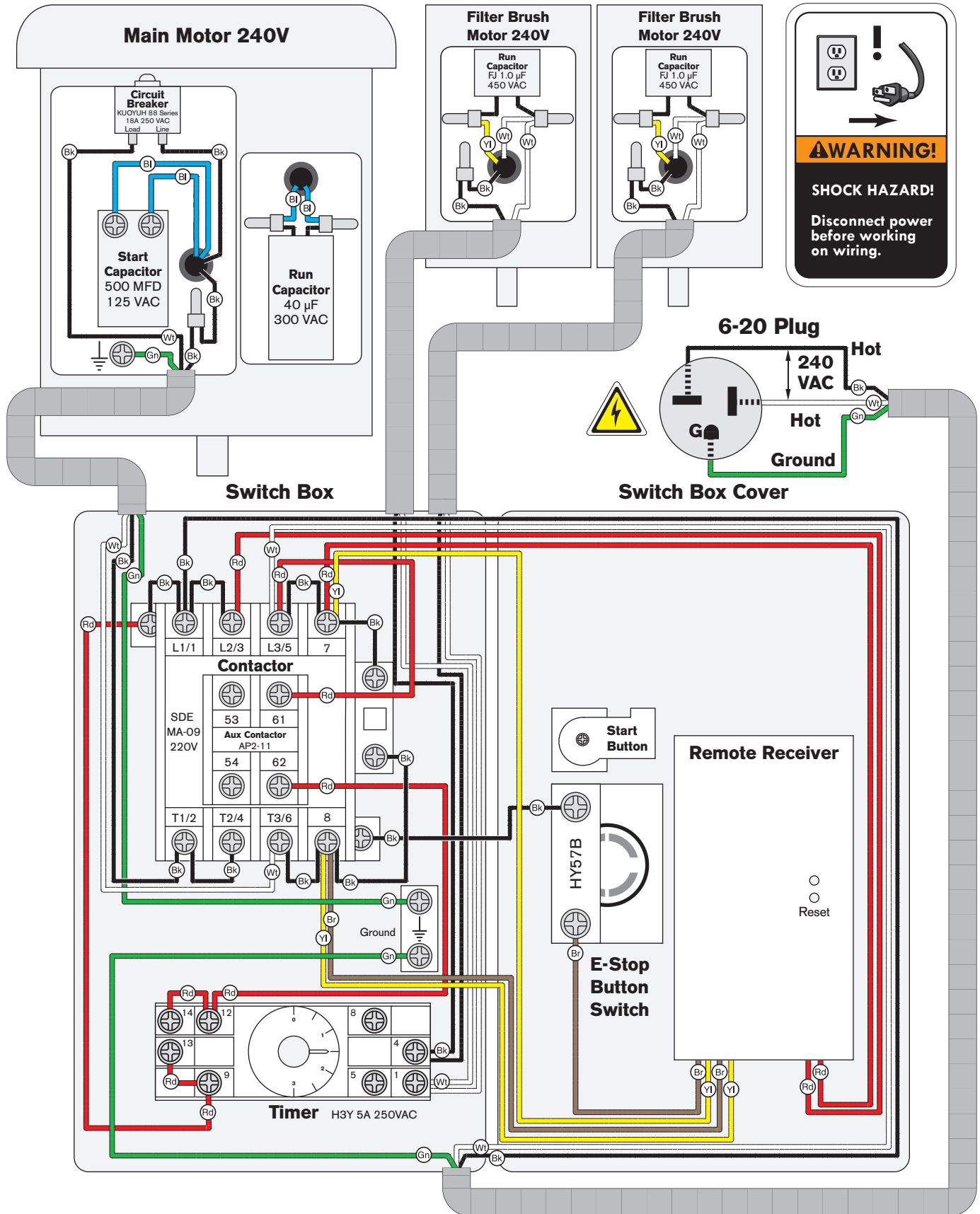


Figure 85. SB1100 start capacitor.



Figure 87. SB1100 remote.

# SB1101 Wiring Diagram



**WARNING!**

**SHOCK HAZARD!**

Disconnect power before working on wiring.





# SB1101 Electrical Component Pictures

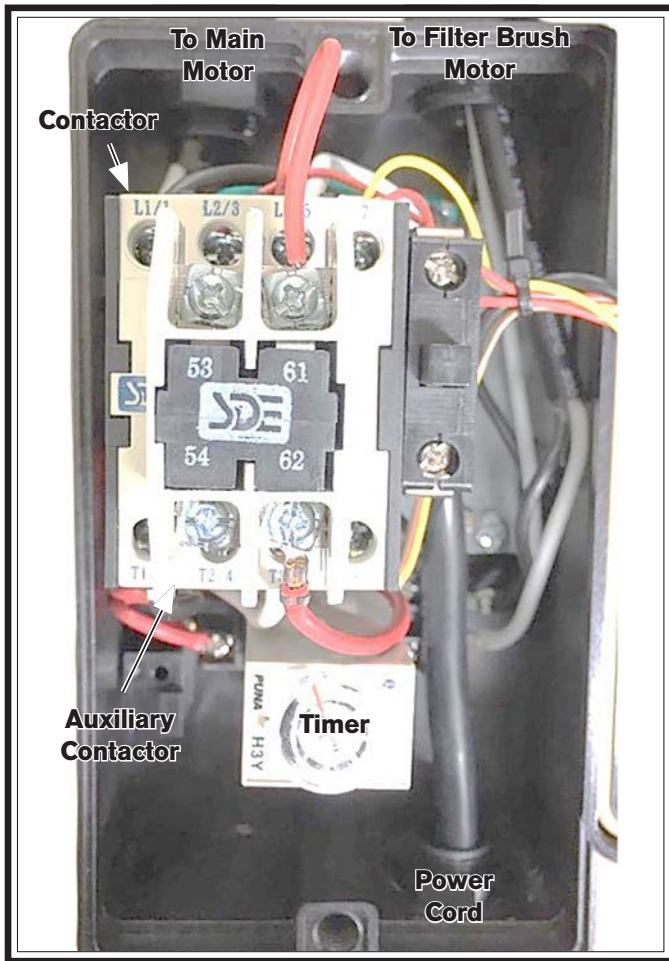


Figure 88. SB1101 switch box interior.

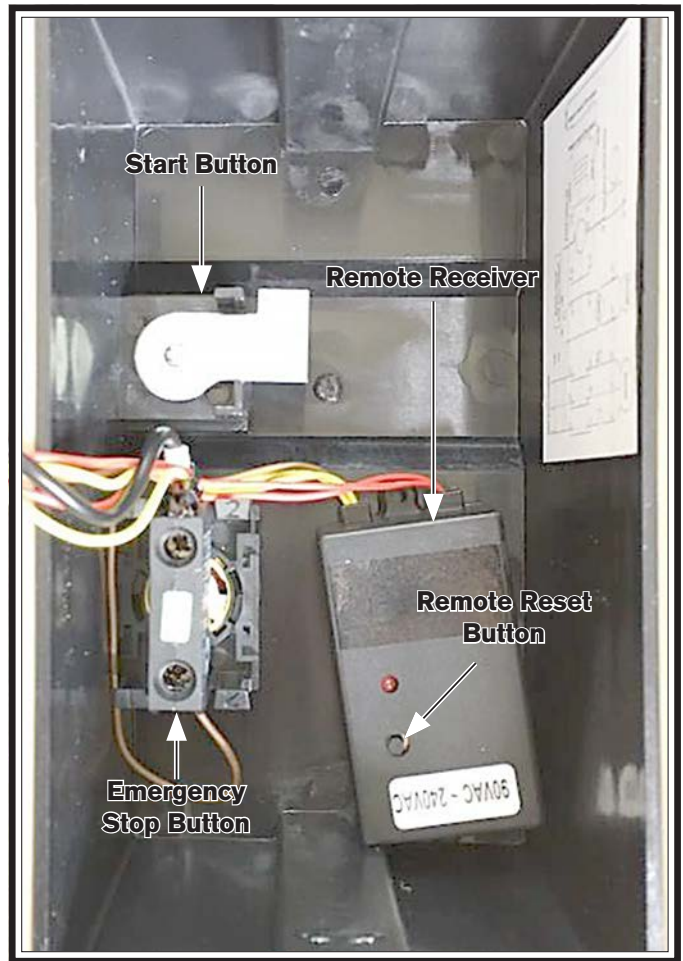


Figure 89. SB1101 switch box cover.

# SB1101 Electrical Component Pictures (Cont.)

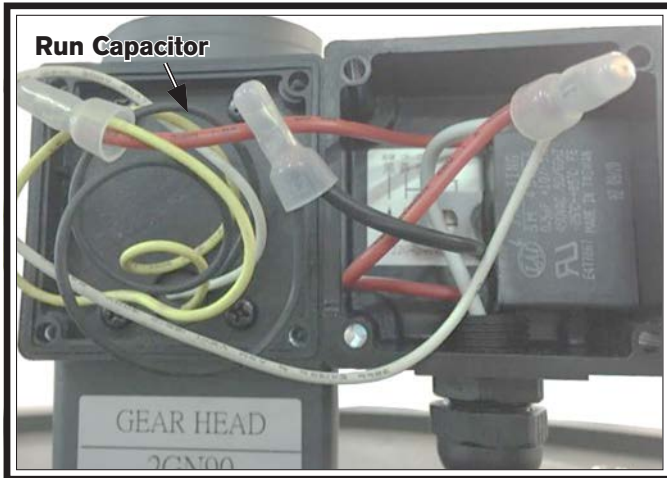


Figure 90. SB1101 filter brush motor junction box.

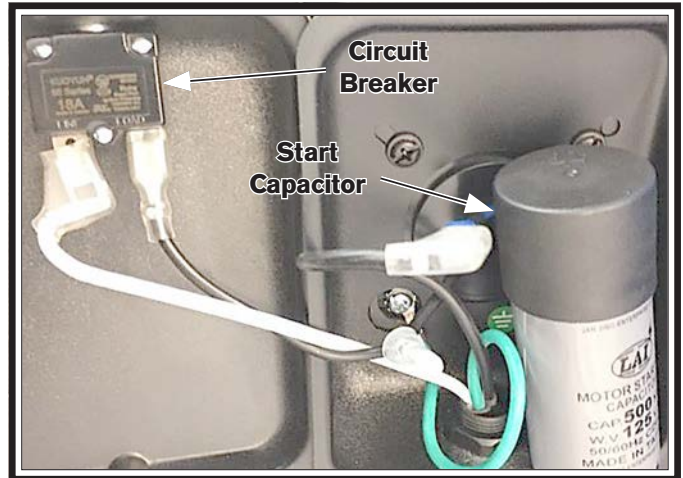


Figure 93. SB1101 main motor junction box.



Figure 91. SB1101 run capacitor.



Figure 94. SB1101 remote.

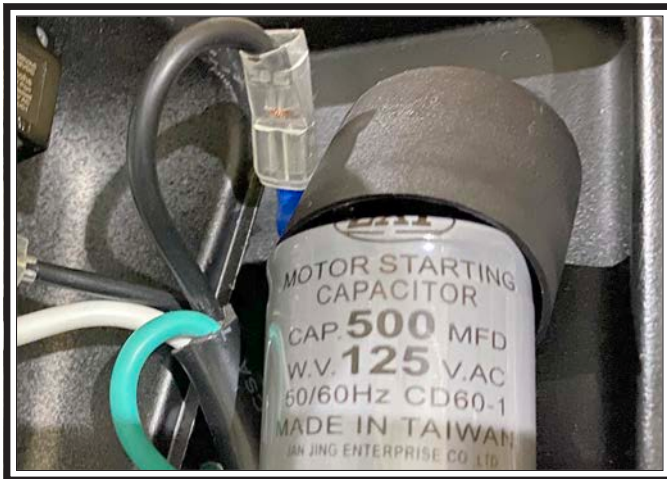
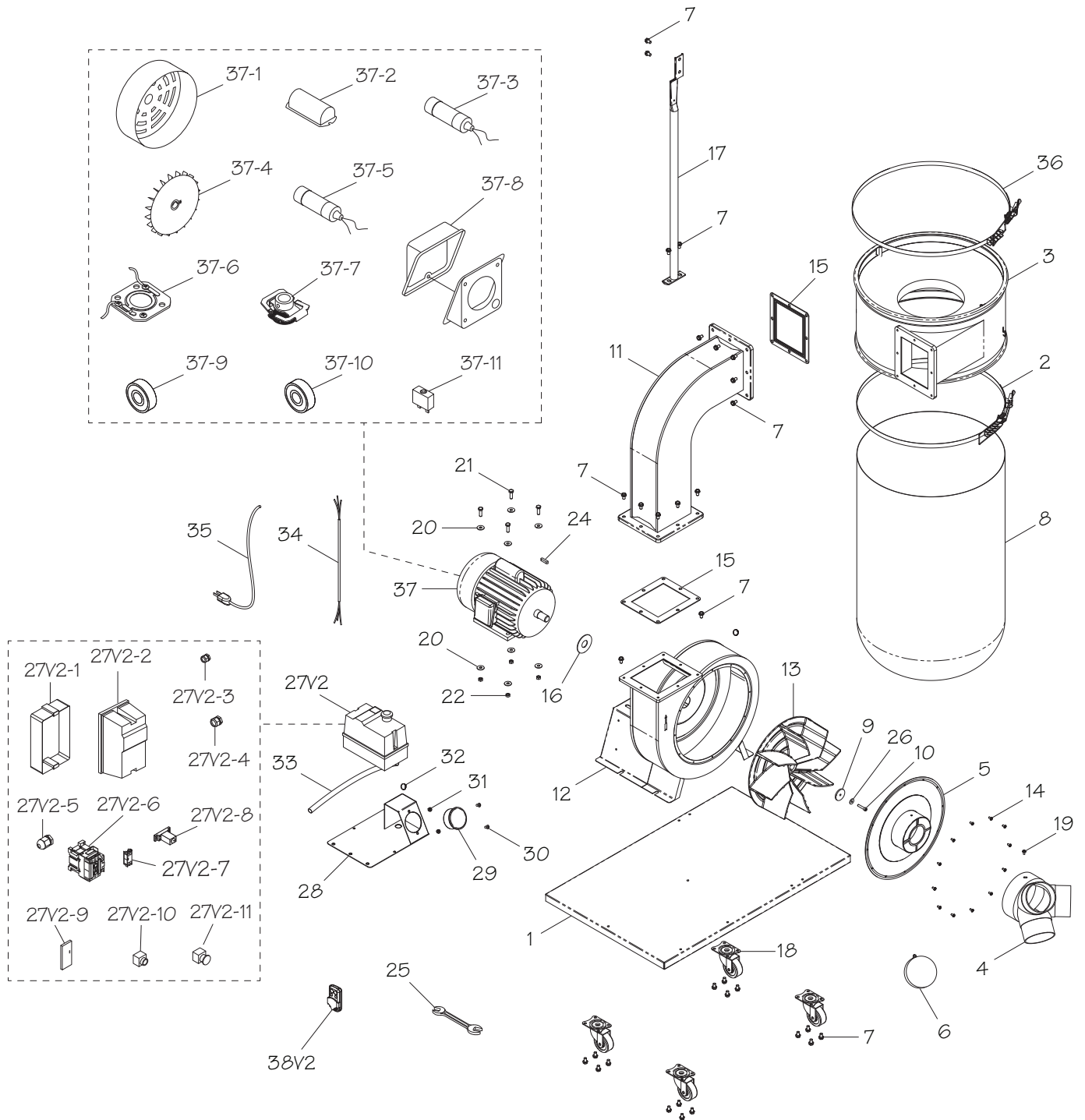


Figure 92. SB1101 start capacitor.



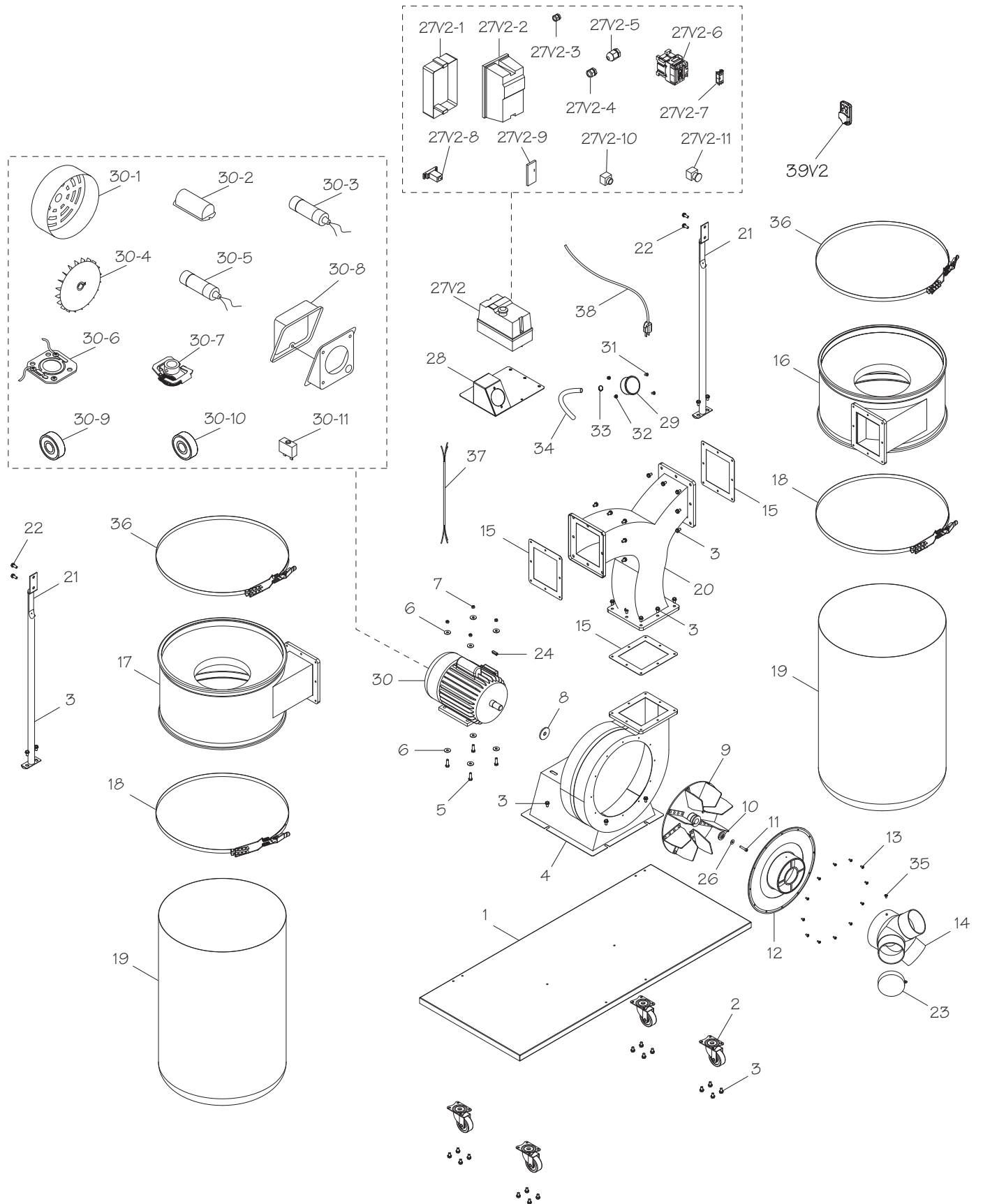
# SB1100 Main



# SB1100 Parts List

REF	PART #	DESCRIPTION	REF	PART #	DESCRIPTION
1	PSB1100001	BASE	27V2-5	PSB1100027V2-5	STRAIN RELIEF TYPE-3 M30
2	PSB1100002	BAG CLAMP 500MM	27V2-6	PSB1100027V2-6	CONTACTOR SDE MA-09 220V
3	PSB1100003	COLLECTOR	27V2-7	PSB1100027V2-7	AUX CONTACTOR SDE AP2-11
4	PSB1100004	INLET ADAPTER 6" X 4" X 3	27V2-8	PSB1100027V2-8	TIMER PUNA H3Y-2 240V
5	PSB1100005	HOUSING COVER	27V2-9	PSB1100027V2-9	REMOTE CONTROL RECEIVER
6	PSB1100006	INLET CAP 4"	27V2-10	PSB1100027V2-10	BUTTON SDE CP GRN
7	PSB1100007	FLANGE BOLT 5/16-18 X 1/2	27V2-11	PSB1100027V2-11	E-STOP BUTTON SDE HY57B 22MM
8	PSB1100008	FILTER BAG	28	PSB1100028	GAUGE BRACKET
9	PSB1100009	IMPELLER WASHER	29	PSB1100029	PRESSURE GAUGE
10	PSB1100010	CAP SCREW M6-1 X 30 LH	30	PSB1100030	BUTTON HD CAP SCR 1/4-20 X 1/2
11	PSB1100011	L-SHAPE OUTLET TUBE	31	PSB1100031	HEX NUT 1/4-20
12	PSB1100012	IMPELLER HOUSING	32	PSB1100032	HOSE CLAMP 3/4"
13	PSB1100013	IMPELLER 12-3/4"	33	PSB1100033	HOSE 1/2"
14	PSB1100014	PHLP HD SCR 10-24 X 3/8	34	PSB1100034	MOTOR CORD 14G 3W 26"
15	PSB1100015	SQUARE GASKET	35	PSB1100035	POWER CORD 14G 3W 65" 6-15P
16	PSB1100016	MOTOR GASKET	36	PSB1100036	CANISTER CLAMP 520MM
17	PSB1100017	CANISTER SUPPORT	37	PSB1100037	MOTOR 2HP 220V 1-PH
18	PSB1100018	CASTER 2-1/2", SWIVEL	37-1	PSB1100037-1	MOTOR FAN COVER
19	PSB1100019	PHLP HD SCR 10-24 X 3/8	37-2	PSB1100037-2	CAPACITOR COVER
20	PSB1100020	FENDER WASHER 5/16	37-3	PSB1100037-3	S CAPACITOR 300M 125V 1-3/4 X 3-1/2
21	PSB1100021	HEX BOLT 5/16-18 X 1	37-4	PSB1100037-4	MOTOR FAN
22	PSB1100022	HEX NUT 5/16-18	37-5	PSB1100037-5	R CAPACITOR 30M 250V 1-3/8 X 2-3/8
24	PSB1100024	KEY 7 X 7 X 25	37-6	PSB1100037-6	CONTACT PLATE
25	PSB1100025	WRENCH 10 X 12MM OPEN-ENDS	37-7	PSB1100037-7	CENTRIFUGAL SWITCH
26	PSB1100026	LOCK WASHER 1/4	37-8	PSB1100037-8	JUNCTION BOX
27V2	PSB1100027V2	MAGNETIC SWITCH SDE MP-30 220V V2.05.21	37-9	PSB1100037-9	FRONT MOTOR BEARING 6205ZZ
27V2-1	PSB1100027V2-1	MAG SWITCH REAR COVER	37-10	PSB1100037-10	REAR MOTOR BEARING 6203ZZ
27V2-2	PSB1100027V2-2	MAG SWITCH FRONT COVER	37-11	PSB1100037-11	CIRCUIT BREAKER 15A KUOYUH 88 SERIES
27V2-3	PSB1100027V2-3	STRAIN RELIEF TYPE-3 M16	38V2	PSB1100038V2	REMOTE V2.05.21
27V2-4	PSB1100027V2-4	STRAIN RELIEF TYPE-3 M20			

# SB1101 Main

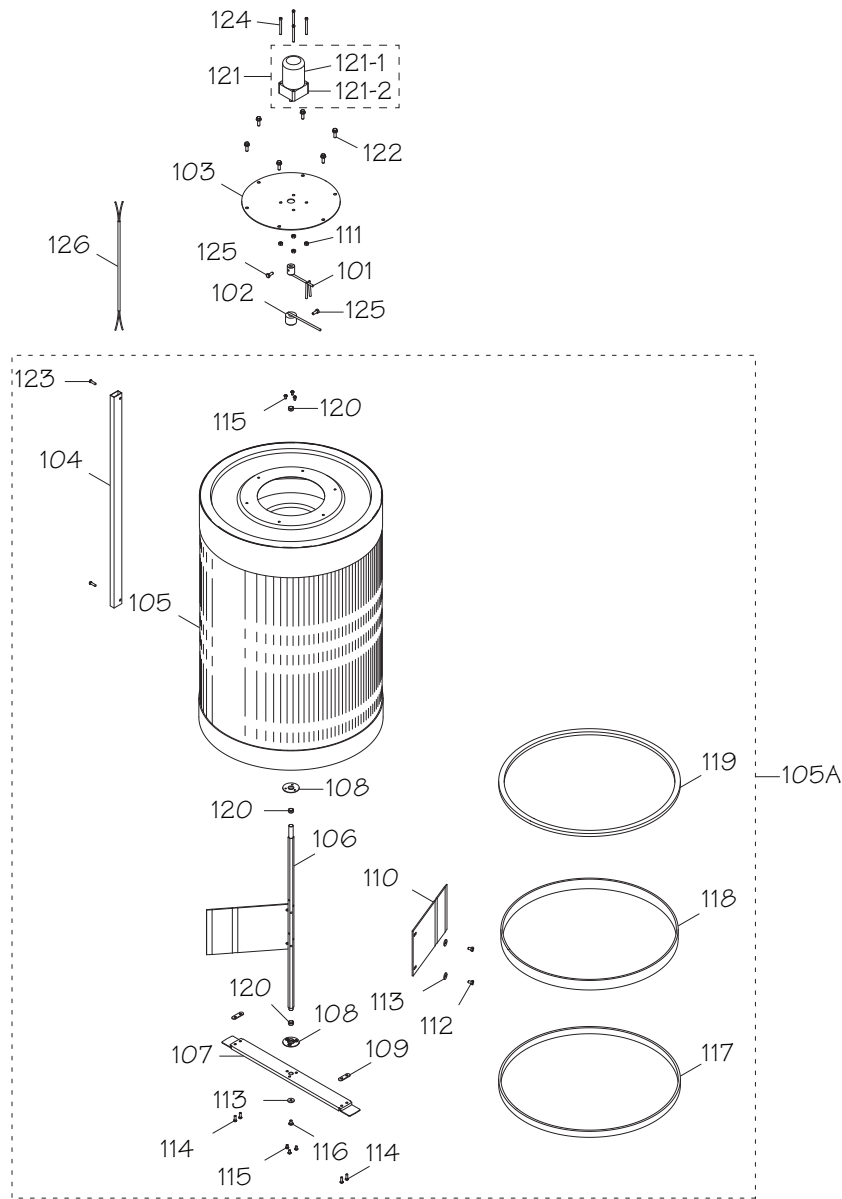


# SB1101 Parts List

REF	PART #	DESCRIPTION
1	PSB1101001	BASE
2	PSB1101002	CASTER 2-1/2", SWIVEL
3	PSB1101003	FLANGE BOLT 5/16-18 X 1/2
4	PSB1101004	IMPELLER HOUSING
5	PSB1101005	HEX BOLT 5/16-18 X 1
6	PSB1101006	FENDER WASHER 5/16
7	PSB1101007	HEX NUT 5/16-18
8	PSB1101008	MOTOR GASKET
9	PSB1101009	IMPELLER 12-3/4"
10	PSB1101010	IMPELLER WASHER
11	PSB1101011	CAP SCREW M6-1 X 30 LH
12	PSB1101012	HOUSING COVER
13	PSB1101013	PHLP HD SCR 10-24 X 3/8
14	PSB1101014	INLET ADAPTER 7" X 4" X 3
15	PSB1101015	SQUARE GASKET
16	PSB1101016	RIGHT COLLECTOR
17	PSB1101017	LEFT COLLECTOR
18	PSB1101018	BAG CLAMP 500MM
19	PSB1101019	FILTER BAG
20	PSB1101020	Y-SHAPE OUTLET TUBE
21	PSB1101021	CANISTER SUPPORT
22	PSB1101022	FLANGE BOLT 5/16-18 X 3/4
23	PSB1101023	INLET CAP 4"
24	PSB1101024	KEY 7 X 7 X 25
26	PSB1101026	LOCK WASHER 1/4
27V2	PSB1101027V2	MAGNETIC SWITCH SDE MP-30 220V V2.05.21
27V2-1	PSB1101027V2-1	MAG SWITCH REAR COVER
27V2-2	PSB1101027V2-2	MAG SWITCH FRONT COVER
27V2-3	PSB1101027V2-3	STRAIN RELIEF TYPE-3 M16
27V2-4	PSB1101027V2-4	STRAIN RELIEF TYPE-3 M20

REF	PART #	DESCRIPTION
27V2-5	PSB1101027V2-5	STRAIN RELIEF TYPE-3 M30
27V2-6	PSB1101027V2-6	CONTACTOR SDE MA-09 220V
27V2-7	PSB1101027V2-7	AUX CONTACTOR SDE AP2-11
27V2-8	PSB1101027V2-8	TIMER PUNA H3Y-2 240V
27V2-9	PSB1101027V2-9	REMOTE CONTROL RECEIVER
27V2-10	PSB1101027V2-10	BUTTON SDE CP GRN
27V2-11	PSB1101027V2-11	E-STOP BUTTON SDE HY57B 22MM
28	PSB1101028	GAUGE BRACKET
29	PSB1101029	PRESSURE GAUGE
30	PSB1101030	MOTOR 3HP 220V 1-PH
30-1	PSB1101030-1	MOTOR FAN COVER
30-2	PSB1101030-2	CAPACITOR COVER
30-3	PSB1101030-3	R CAPACITOR 40M 300V 1-1/2 X 2-3/4
30-4	PSB1101030-4	MOTOR FAN
30-5	PSB1101030-5	S CAPACITOR 500M 125V 1-3/8 X 2-5/8
30-6	PSB1101030-6	CONTACT PLATE
30-7	PSB1101030-7	CENTRIFUGAL SWITCH
30-8	PSB1101030-8	JUNCTION BOX
30-9	PSB1101030-9	FRONT MOTOR BEARING 6205ZZ
30-10	PSB1101030-10	REAR MOTOR BEARING 6203ZZ
30-11	PSB1101030-11	CIRCUIT BREAKER 18A KUOYUH 88 SERIES
31	PSB1101031	BUTTON HD CAP SCR 1/4-20 X 1/2
32	PSB1101032	HEX NUT 1/4-20
33	PSB1101033	HOSE CLAMP 3/4"
34	PSB1101034	HOSE 1/2"
35	PSB1101035	PHLP HD SCR 10-24 X 3/8
36	PSB1101036	CANISTER CLAMP 520MM
37	PSB1101037	MOTOR CORD 14G 3W 26"
38	PSB1101038	POWER CORD 14G 3W 64" 6-20P
39V2	PSB1101039V2	REMOTE V2.05.21

# Canister Filter

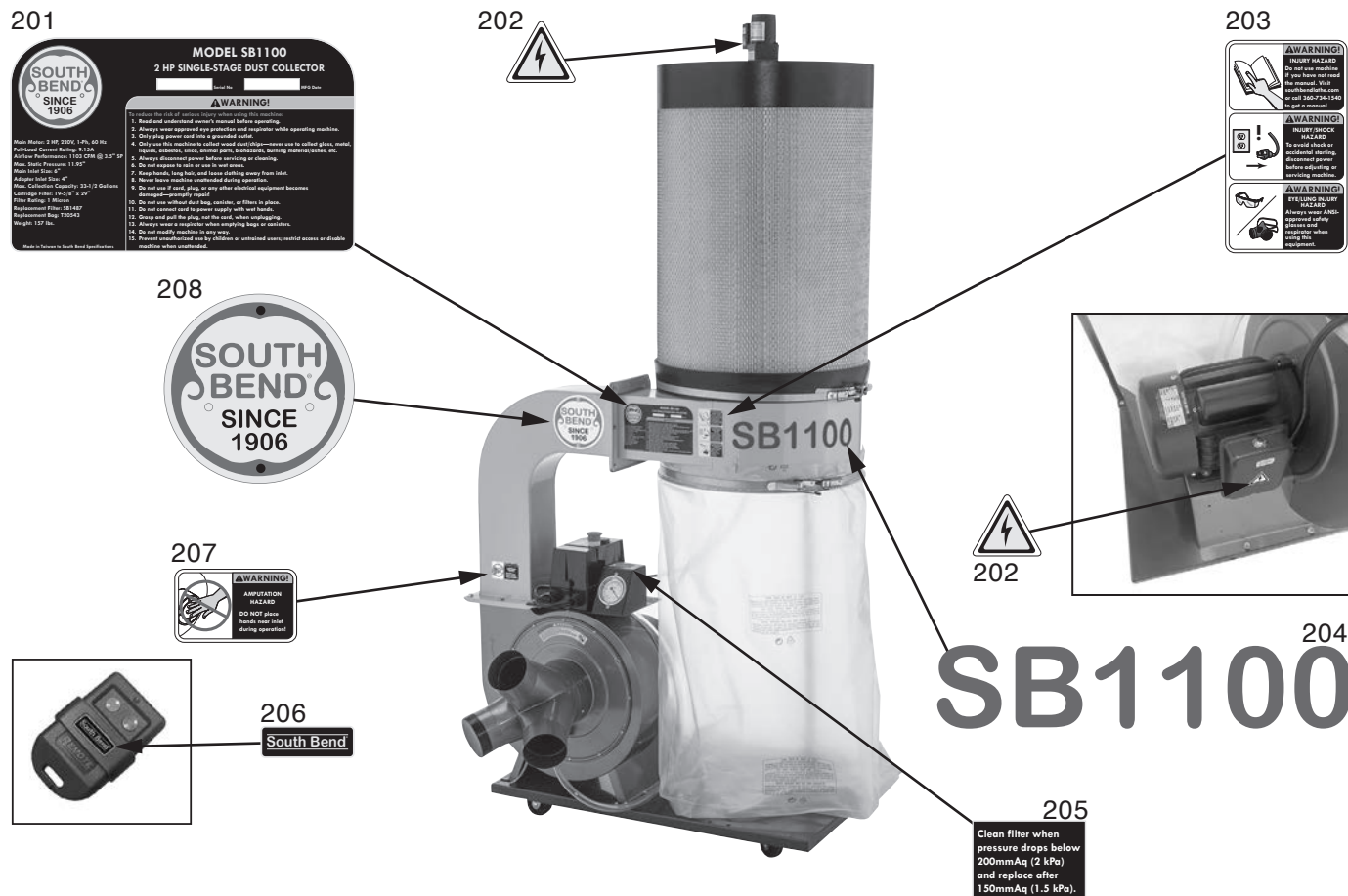


REF	PART #	DESCRIPTION
101	PSB1100101	UPPER SPINDLE LEVER
102	PSB1100102	LOWER SPINDLE LEVER
103	PSB1100103	FILTER COVER
104	PSB1100104	CORD ROUTING COVER
105A	PSB1100105A	CANISTER FILTER ASSEMBLY
105	PSB1100105	CANISTER FILTER
106	PSB1100106	FILTER BRUSH SPINDLE
107	PSB1100107	LOWER BRACKET
108	PSB1100108	BEARING FIXING PLATE
109	PSB1100109	SUPPORT TAB
110	PSB1100110	PADDLE BRUSH
111	PSB1100111	HEX NUT M5-.8
112	PSB1100112	PHLP HD SCR M6-1 X 12
113	PSB1100113	FLAT WASHER 1/4
114	PSB1100114	PHLP HD SCR M5-.8 X 15

REF	PART #	DESCRIPTION
115	PSB1100115	PHLP HD SCR M5-.8 X 8
116	PSB1100116	PHLP HD SCR M6-1 X 10
117	PSB1100117	FOAM GASKET 20 X 1560MM
118	PSB1100118	FOAM GASKET 42 X 1560MM
119	PSB1100119	FOAM GASKET 10 X 1560MM
120	PSB1100120	THRUST BEARING 12 X 14 X 6MM
121	PSB1100121	FILTER BRUSH MOTOR ASSEMBLY
121-1	PSB1100121-1	MOTOR 6W 220V 1-PH
121-2	PSB1100121-2	GEAR REDUCER 2GN90
122	PSB1100122	FLANGE BOLT 1/4-20 X 3/4
123	PSB1100123	PHLP HD SCR M5-.8 X 10
124	PSB1100124	CAP SCREW M5-.8 X 50
125	PSB1100125	HEX BOLT M6-1 X 16
126	PSB1100126	MOTOR CORD 18G 2W 66"



# Machine Labels



REF	PART #	DESCRIPTION
201	PSB1100201	MACHINE ID LABEL (SB1100)
201	PSB1101201	MACHINE ID LABEL (SB1101)
202	PSB1100202	ELECTRICITY LABEL
203	PSB1100203	DUST COLLECTOR COMBO LABEL
204	PSB1100204	MODEL NUMBER LABEL (SB1100)

REF	PART #	DESCRIPTION
204	PSB1101204	MODEL NUMBER LABEL (SB1101)
205	PSB1100205	VACUUM PRESSURE GAUGE LABEL
206	PSB1100206	REMOTE LABEL
207	PSB1100207	AMPUTATION HAZARD LABEL
208	PSB1100208	SOUTH BEND NAMEPLATE 125MM

**⚠ WARNING**

The safety labels provided with your machine are used to make the operator aware of the machine hazards and ways to prevent injury. The owner of this machine **MUST** maintain the original location and readability of these safety labels. If any label is removed or becomes unreadable, **REPLACE** that label before using the machine again. Contact South Bend Tools at (360) 734-1540 or [www.southbendtools.com](http://www.southbendtools.com) to order new labels.

# Warranty

This quality product is warranted by South Bend Tools to the original buyer for **2 years** from the date of purchase. This warranty does not apply to consumable parts, or defects due to any kind of misuse, abuse, negligence, accidents, repairs, alterations or lack of maintenance. We do not reimburse for third party repairs. In no event shall we be liable for death, injuries to persons or property, or for incidental, contingent, special or consequential damages arising from the use of our products.

We do not warrant or represent that this machine complies with the provisions of any law, act, code, regulation, or standard of any domestic or foreign government, industry, or authority. In no event shall South Bend's liability under this warranty exceed the original purchase price paid for this machine. Any legal actions brought against South Bend Tools shall be tried in the State of Washington, County of Whatcom.

This is the sole written warranty for this machine. Any and all warranties that may be implied by law, including any merchantability or fitness, for any purpose, are hereby limited to the duration of this warranty.

Thank you for your business and continued support.

To take advantage of this warranty, register at <https://www.grizzly.com/forms/warranty>, or you can scan the QR code below to be automatically directed to our warranty registration page. Enter all applicable information for the product.





[southbendtools.com](http://southbendtools.com)



Printed In U.S.A.

#A121261