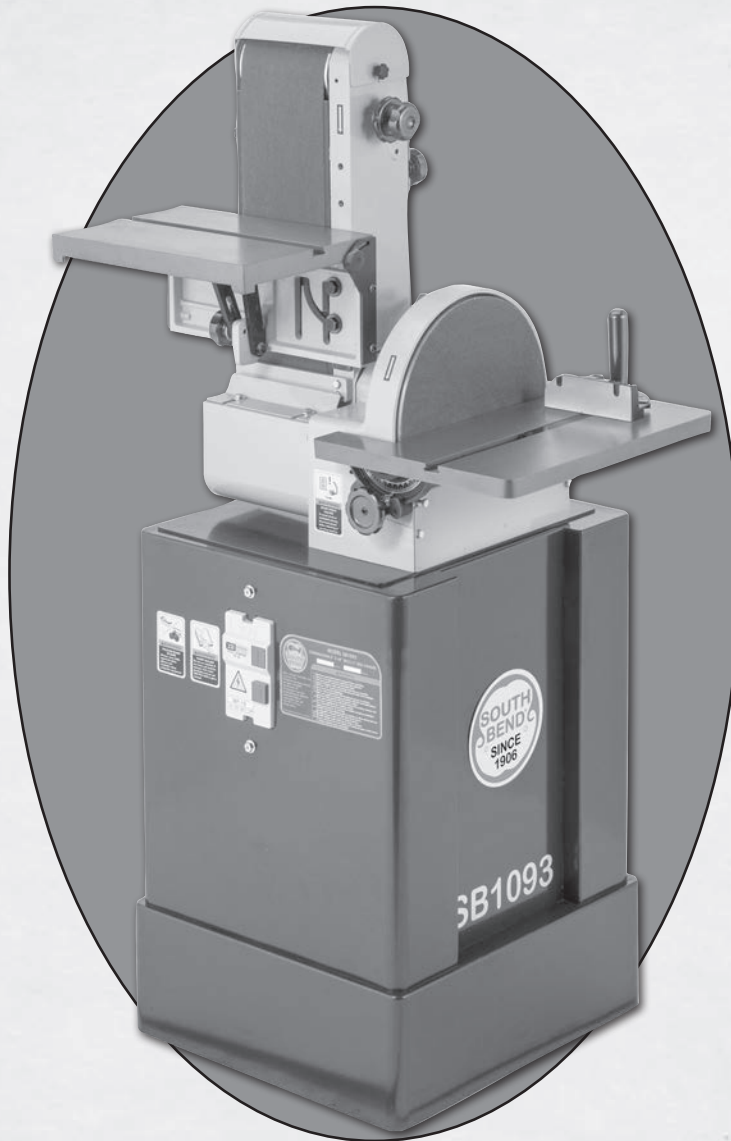


# 6" X 48" BELT/12" DISC COMBO SANDER MODEL SB1093



## OWNER'S MANUAL

---

# South Bend Tools®

---

*A Tradition of Excellence*



# Scope of Manual

This manual helps the reader understand the machine, how to prepare it for operation, how to control it during operation, and how to keep it in good working condition. We assume the reader has a basic understanding of how to operate this type of machine, but that the reader is not familiar with the controls and adjustments of this specific model. As with all machinery of this nature, learning the nuances of operation is a process that happens through training and experience. If you are not an experienced operator of this type of machinery, read through this entire manual, then learn more from an experienced operator, schooling, or research before attempting operations. Following this advice will help you avoid serious personal injury and get the best results from your work.

# Manual Feedback

We've made every effort to be accurate when documenting this machine. However, errors sometimes happen or the machine design changes after the documentation process—so the manual may not exactly match your machine. If a difference between the manual and machine leaves you in doubt, contact our customer service for clarification.

We highly value customer feedback on our manuals. If you have a moment, please share your experience using this manual. What did you like about it? Is there anything you would change to make it better? Did it meet your expectations for clarity, professionalism, and ease-of-use?

**South Bend Tools**  
**c/o Technical Documentation Manager**  
**P.O. Box 2027**  
**Bellingham, WA 98227**  
**Email: [manuals@southbendtools.com](mailto:manuals@southbendtools.com)**

# Updates

For your convenience, any updates to this manual will be available to download free of charge through our website at:

**[www.southbendtools.com](http://www.southbendtools.com)**

# Customer Service

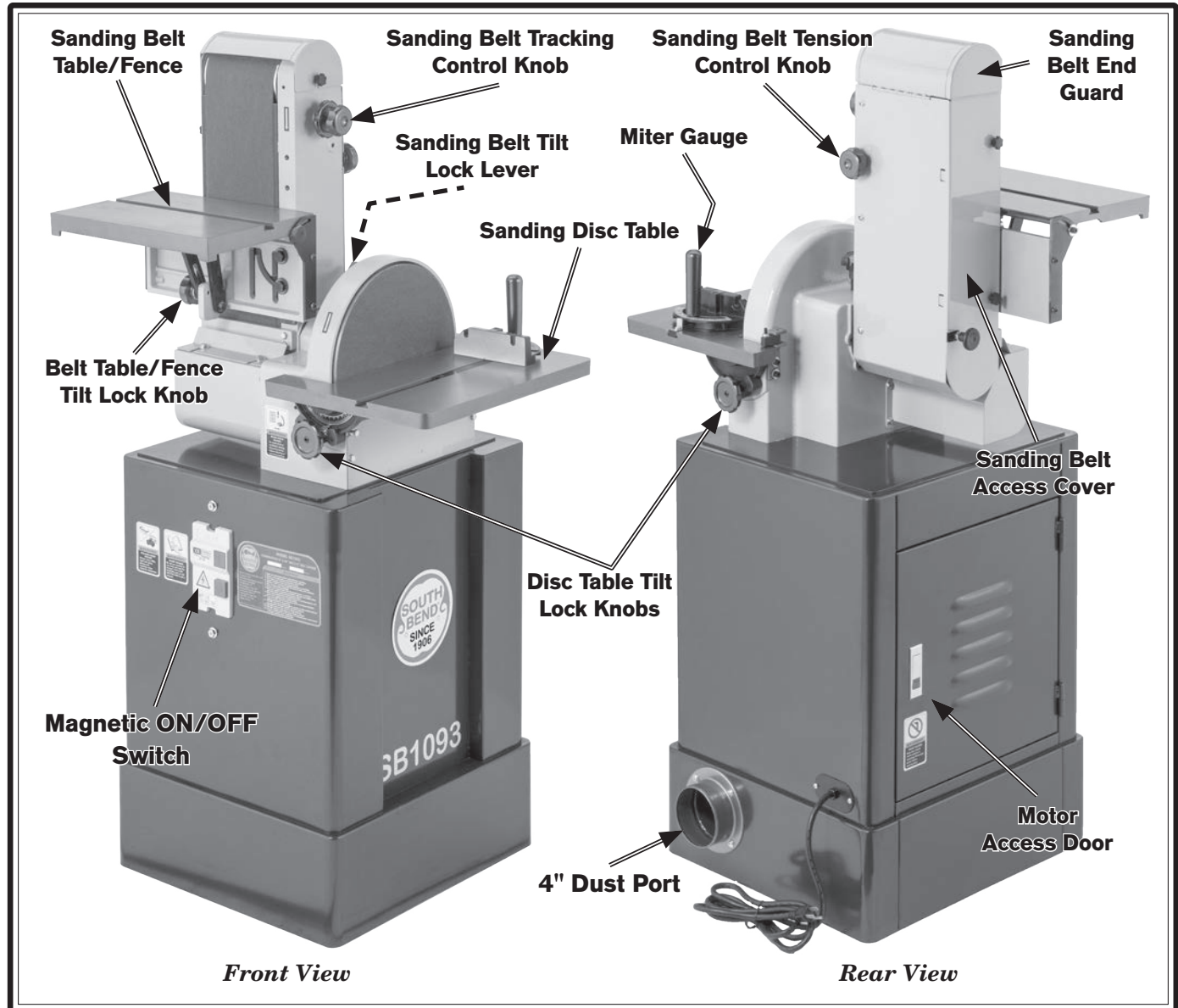
We stand behind our machines. If you have any service questions, parts requests or general questions about your purchase, feel free to contact us.

**South Bend Tools**  
**P.O. Box 2027**  
**Bellingham, WA 98227**  
**Phone: (360) 734-1540**  
**Fax: (360) 676-1075 (International)**  
**Fax: (360) 734-1639 (USA Only)**  
**Email: [sales@southbendtools.com](mailto:sales@southbendtools.com)**

# Table of Contents

<b>INTRODUCTION.....</b>	<b>2</b>	<b>ACCESSORIES.....</b>	<b>33</b>
Identification.....	2	<b>MAINTENANCE.....</b>	<b>35</b>
Description of Controls & Components.....	3	Maintenance Schedule.....	35
Product Specifications.....	5	Cleaning & Protecting.....	35
<b>SAFETY.....</b>	<b>7</b>	Machine Storage.....	35
Understanding Risks of Machinery.....	7	<b>SERVICE.....</b>	<b>36</b>
Basic Machine Safety.....	7	Tensioning/Replacing V-Belt.....	36
Additional Combination Sander Safety.....	9	<b>TROUBLESHOOTING.....</b>	<b>38</b>
<b>PREPARATION.....</b>	<b>10</b>	<b>ELECTRICAL.....</b>	<b>40</b>
Preparation Overview.....	10	Electrical Safety Instructions.....	40
Required for Setup.....	10	Wiring Diagram.....	41
Power Supply Requirements.....	11	Electrical Component Pictures.....	42
Converting Voltage to 230V.....	13	<b>PARTS.....</b>	<b>44</b>
Unpacking.....	15	Machine Body.....	44
Inventory.....	15	Stand.....	46
Cleaning & Protecting.....	16	Miter Gauge.....	47
Location.....	17	Machine Labels.....	48
Assembly.....	18	Warranty.....	49
Dust Collection.....	21		
Test Run.....	22		
<b>OPERATION.....</b>	<b>23</b>		
Operation Overview.....	23		
Sanding Tips.....	24		
Choosing Sandpaper.....	24		
Stock Inspection and Requirements.....	24		
Horizontal Sanding.....	25		
Contour Sanding.....	27		
Vertical Sanding.....	27		
Disc Sanding.....	29		
Changing Sanding Belt.....	30		
Tensioning Sanding Belt.....	30		
Tracking Sanding Belt.....	31		
Changing Sanding Disc.....	32		

# Identification



## **⚠️ WARNING**

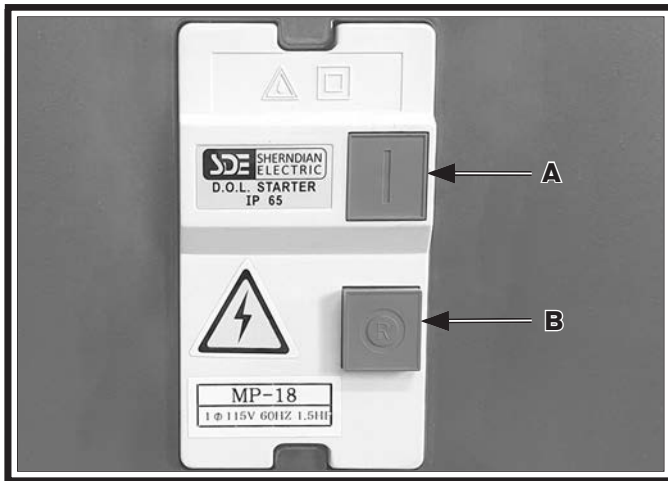
**For Your Own Safety Read Instruction Manual Before Operating Sander**

- a) Wear eye protection.
- b) Support workpiece with miter gauge, backstop, or worktable.
- c) Maintain  $\frac{1}{16}$ " maximum clearance between table and sanding belt or disc.

# Description of Controls & Components

Refer to **Figures 1–5** and the following descriptions to become familiar with the basic controls and components used to operate this machine.

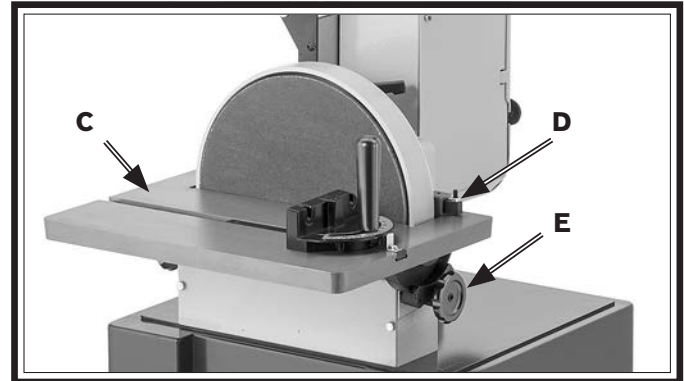
## Power Controls



**Figure 1. Power ON/OFF Switch.**

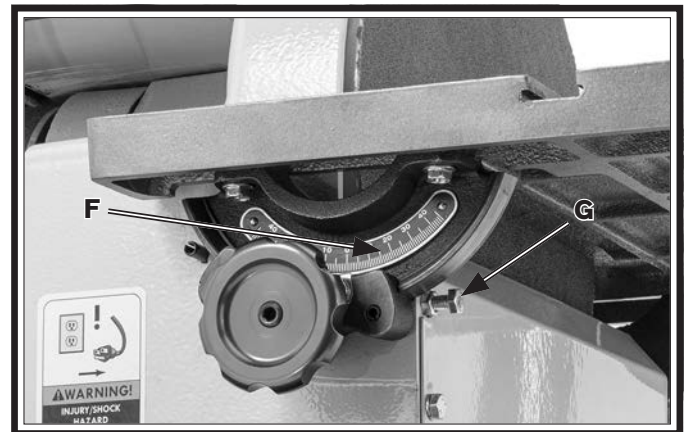
- A. Green Power ON Button:** Press to turn motor *ON*.
- B. Red Power OFF Button:** Press to turn motor *OFF*.

## Disc Sander



**Figure 2. Disc sander features.**

- C. Sanding Disc Work Table:** Supports workpiece as it is being moved back and forth against sanding disc.
- D. 90° Tilt Stop:** Used for quick table tilt adjustments to 90°.
- E. Disc Table Tilt Lock Knob (1 of 2):** Loosen lock knobs on both sides of table for adjustments from 15° up to 45° down.



**Figure 3. Sanding disc table angle scale.**

- F. Sanding Disc Table Angle Scale:** Indicates angle of sanding table.
- G. 45° Tilt Stop:** Factory set at 45°; easily adjusts for quick table tilts when sanding repetitive angles.

## Belt Sander

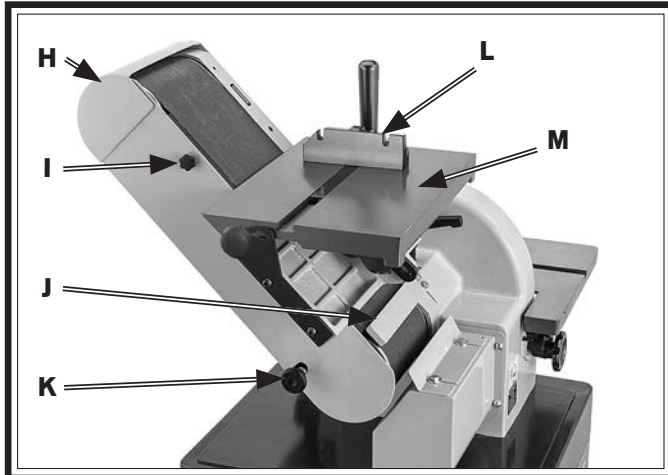


Figure 4. Belt sander features.

- H. Sanding Belt End Guard:** Protects against accidental contact with end of sanding belt. Guard swings open for contour sanding.
- I. Sanding Belt Access Lock Knob (1 of 2):** Secures sanding belt access panel. Remove lock knobs for belt access.
- J. Back Stop:** Prevents workpiece from being ejected from belt. Must be used when belt sander is in horizontal position and table/fence assembly is in fence configuration.
- K. Indexing Pin:** Positive locking pin stops belt sander tilt at 0° (vertical), 45°, and 90° (horizontal).
- L. Miter Gauge:** Used for miter sanding. Adjustable from 60° left–60° right.
- M. Sanding Belt Table:** Supports workpiece as it is being moved back and forth against sanding belt.

**Note:** Table may also be configured to use as a fence when belt sander is used in the horizontal position.

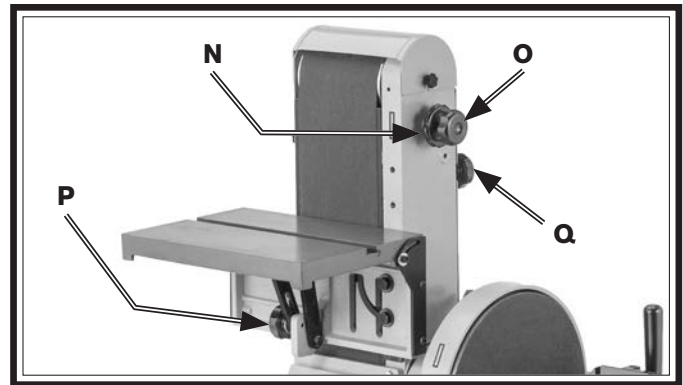


Figure 5. Belt sander controls.

- N. Sanding Belt Tracking Lock Knob:** Loosen lock knob to allow movement of sanding belt tracking knob, tighten to lock tracking knob in place.
- O. Sanding Belt Tracking Knob:** Controls side-to-side tracking of sanding belt.
- P. Table Tilt Lock Knob:** Loosen lock knob to adjust work table to desired angle.
- Q. Sanding Belt Tension Knob:** Turns clockwise to increase tension on sanding belt, turns counter-clockwise to decrease tension.

	<h1 style="margin: 0;">Product Specifications</h1> <p style="margin: 5px 0;">P.O. Box 2027, Bellingham, WA 98227 U.S.A.                  PHONE: (360) 734-1540 • © South Bend Tools  <a href="http://www.southbendtools.com">www.southbendtools.com</a></p>	
---	---	---

## Model SB1093

# 6" x 48" Belt / 12" Disc Combination Sander

**Product Dimensions**

Weight..... 268 lbs.  
 Width (side-to-side) x Depth (front-to-back) x Height..... 28 x 30 x 54-1/2 in.  
 Footprint (Length x Width)..... 21 x 19 in.

**Shipping Dimensions**

Type..... Wood Crate  
 Content..... Machine  
 Weight..... 327 lbs.  
 Length x Width x Height..... 33 x 24 x 48 in.  
 Must Ship Upright..... Yes

**Electrical**

Power Requirement..... 115V or 230V, Single-Phase, 60 Hz  
 Prewired Voltage..... 115V  
 Full-Load Current Rating..... 14A at 115V, 7A at 230V  
 Minimum Circuit Size..... 15A  
 Connection Type..... Cord & Plug  
 Power Cord Included..... Yes  
 Power Cord Length..... 78 in.  
 Power Cord Gauge..... 14 AWG  
 Plug Included..... Yes  
 Included Plug Type..... 5-15 for 115V  
 Recommended Plug Type..... 6-15 for 230V  
 Switch Type..... Magnetic Switch w/Overload Protection

**Motors**

**Main**

Horsepower..... 1.5 HP  
 Phase..... Single-Phase  
 Amps..... 14A/7A  
 Speed..... 1725 RPM  
 Type..... TEFC Capacitor-Start Induction  
 Power Transfer ..... Belt  
 Bearings..... Shielded & Permanently Lubricated  
 Centrifugal Switch/Contacts Type..... External

**Main Specifications**

**Belt Sander Info**

Sanding Belt Width.....	6 in.
Sanding Belt Length.....	48 in.
Sanding Belt Speed.....	2690 FPM
Sanding Belt Tilt.....	90 deg.
Table Length.....	14 in.
Table Width.....	10 in.
Table Thickness.....	1 in.
Table Tilt.....	0 - 45 deg.
Table-to-Floor Height.....	43 in.
Max Height of Belt in Vertical Position.....	53 in.
Belt Tension Release Type.....	Quick-Release Knob
Platen Type.....	Cast Iron
Platen Length.....	14-1/2 in.
Platen Width.....	6 in.

**Disc Sander Info**

Disc Diameter.....	12 in.
Disc Speed.....	2360 RPM
Disc Sandpaper Backing Type.....	PSA
Table Length.....	17-3/8 in.
Table Width.....	9 in.
Table Thickness.....	1 in.
Table Tilt.....	Up 15, Down 45 deg.
Table-to-Floor Height.....	34-1/2 in.

**Construction Materials**

Base.....	Pre-Formed Steel
Table.....	Precision-Ground Cast Iron
Disc.....	Aluminum
Miter Gauge.....	Aluminum
Paint Type/Finish.....	Epoxy/Powder Coat

**Other Related Info**

Miter Gauge Slot Width.....	3/4 in.
Miter Gauge Slot Height.....	3/8 in.
Number of Dust Ports.....	1
Dust Port Size.....	4 in.
Compatible Mobile Base.....	T28922

**Other**

Country of Origin .....	Taiwan
Warranty .....	2 Years
Approximate Assembly & Setup Time .....	45 Minutes
Serial Number Location .....	ID Label
Sound Rating .....	82 - 84 dB
ISO 9001 Factory .....	Yes

**Features**

- Two Precision-Ground Cast-Iron Tables
- Heavy-Duty Cabinet Stand
- Heavy-Duty Miter Gauge
- Belt Sander Table Tilts 0-45 Degrees
- Disc Sander Table Tilts Down 45 and Up 15 Degrees






# Understanding Risks of Machinery

Operating all machinery and machining equipment can be dangerous or relatively safe depending on how it is installed and maintained, and the operator's experience, common sense, risk awareness, working conditions, and use of personal protective equipment (safety glasses, respirators, etc.).

The owner of this machinery or equipment is ultimately responsible for its safe use. This responsibility includes proper installation in a safe environment, personnel training and usage authorization, regular inspection and maintenance, manual availability and comprehension, application of safety devices, integrity of cutting tools or accessories, and the usage of approved personal protective equipment by all operators and bystanders.

The manufacturer of this machinery or equipment will not be held liable for injury or property damage from negligence, improper training, machine modifications, or misuse. Failure to read, understand, and follow the manual and safety labels may result in serious personal injury, including amputation, broken bones, electrocution, or death.

The signals used in this manual to identify hazard levels are as follows:

 <b>DANGER</b>	<i>Death or catastrophic harm WILL occur.</i>	 <b>CAUTION</b>	<i>Moderate injury or fire MAY occur.</i>
 <b>WARNING</b>	<i>Death or catastrophic harm COULD occur.</i>	<b>NOTICE</b>	<i>Machine or property damage may occur.</i>

## Basic Machine Safety

**Owner's Manual:** All machinery and machining equipment presents serious injury hazards to untrained users. To reduce the risk of injury, anyone who uses THIS item MUST read and understand this entire manual before starting.

**Personal Protective Equipment:** Operating or servicing this item may expose the user to flying debris, dust, smoke, dangerous chemicals, or loud noises. These hazards can result in eye injury, blindness, long-term respiratory damage, poisoning, cancer, reproductive harm or hearing loss. Reduce your risks from these hazards by wearing approved eye protection, respirator, gloves, or hearing protection.

**Trained/Supervised Operators Only:** Untrained users can seriously injure themselves or bystanders. Only allow trained and properly supervised personnel to operate this item. Make sure safe operation instructions are clearly understood. If electrically powered, use padlocks and master switches, and remove start switch keys to prevent unauthorized use or accidental starting.

**Guards/Covers:** Accidental contact with moving parts during operation may cause severe entanglement, impact, cutting, or crushing injuries. Reduce this risk by keeping any included guards/covers/doors installed, fully functional, and positioned for maximum protection.

**Entanglement:** Loose clothing, gloves, neckties, jewelry or long hair may get caught in moving parts, causing entanglement, amputation, crushing, or strangulation. Reduce this risk by removing/securing these items so they cannot contact moving parts.

**Mental Alertness:** Operating this item with reduced mental alertness increases the risk of accidental injury. Do not let a temporary influence or distraction lead to a permanent disability! Never operate when under the influence of drugs/alcohol, when tired, or otherwise distracted.

**Safe Environment:** Operating electrically powered equipment in a wet environment may result in electrocution; operating near highly flammable materials may result in a fire or explosion. Only operate this item in a dry location that is free from flammable materials.

**Electrical Connection:** With electrically powered equipment, improper connections to the power source may result in electrocution or fire. Always adhere to all electrical requirements and applicable codes when connecting to the power source. Have all work inspected by a qualified electrician to minimize risk.

**Disconnect Power:** Adjusting or servicing electrically powered equipment while it is connected to the power source greatly increases the risk of injury from accidental startup. Always disconnect power **BEFORE** any service or adjustments, including changing blades or other tooling.

**Secure Workpiece/Tooling:** Loose workpieces, cutting tools, or rotating spindles can become dangerous projectiles if not secured or if they hit another object during operation. Reduce the risk of this hazard by verifying that all fastening devices are properly secured and items attached to spindles have enough clearance to safely rotate.

**Chuck Keys or Adjusting Tools:** Tools used to adjust spindles, chucks, or any moving/rotating parts will become dangerous projectiles if left in place when the machine is started. Reduce this risk by developing the habit of always removing these tools immediately after using them.

**Work Area:** Clutter and dark shadows increase the risks of accidental injury. Only operate this item in a clean, non-glaring, and well-lighted work area.

**Properly Functioning Equipment:** Poorly maintained, damaged, or malfunctioning equipment has higher risks of causing serious personal injury compared to those that are properly maintained. To reduce this risk, always maintain this item to the highest standards and promptly repair/service a damaged or malfunctioning component. Always follow the maintenance instructions included in this documentation.

**Unattended Operation:** Electrically powered equipment that is left unattended while running cannot be controlled and is dangerous to bystanders. Always turn the power **OFF** before walking away.

**Health Hazards:** Certain cutting fluids and lubricants, or dust/smoke created when cutting, may contain chemicals known to the State of California to cause cancer, respiratory problems, birth defects, or other reproductive harm. Minimize exposure to these chemicals by wearing approved personal protective equipment and operating in a well ventilated area.

**Difficult Operations:** Attempting difficult operations with which you are unfamiliar increases the risk of injury. If you experience difficulties performing the intended operation, **STOP!** Seek an alternative method to accomplish the same task, ask a qualified expert how the operation should be performed, or contact our Technical Support for assistance.

# Additional Combination Sander Safety

## ⚠️ WARNING

**Serious injury or death can occur from fingers, clothing, jewelry, or hair getting pinched/entangled in rotating disc, belt, spindle or other moving components. Abrasion injuries can occur from touching moving sandpaper with bare skin. Workpieces thrown by sanding surface can strike operator or bystanders with moderate force, causing impact injuries. Long-term respiratory damage can occur from using sander without proper use of a respirator. To reduce the risk of these hazards, operator or bystanders MUST completely heed the hazards and warnings below.**

**Sandpaper Direction:** Feeding workpiece incorrectly can cause it to be thrown from machine, striking operator or bystanders, or causing your hands to slip into the moving sandpaper. To reduce these risks, only sand against direction of sandpaper travel, ensure workpiece is properly supported, and avoid introducing sharp edges into moving sandpaper on the leading side of the workpiece.

**In-running Nip Points:** The gap between moving sandpaper and fixed table/support creates a pinch point for fingers or workpieces; the larger this gap is, the greater the risk of fingers or workpieces getting caught in it. Minimize this risk by adjusting table/support to no more than 1/16" away from sandpaper.

**Hand Placement:** Rotating sandpaper can remove skin quickly. Always keep hands away from moving sandpaper during operation. Stop machine to clean table of sawdust and chips.

**Minimum Stock Dimension:** Small workpieces can be aggressively pulled from your hands, causing contact with sanding surface. Always use a jig or other holding device when sanding small workpieces, and keep hands and fingers at least 2" away from sanding surface.

**Feeding Workpiece:** Forcefully jamming workpiece into sanding surface could cause it to be grabbed aggressively, pulling hands into sanding surface. Firmly grasp workpiece in both hands and ease it into sandpaper using light pressure.

**Avoiding Entanglement:** Becoming entangled in moving parts can cause pinching and crushing injuries. To avoid these hazards, keep all guards in place and closed. DO NOT wear loose clothing, gloves, or jewelry, and tie back long hair.

**Workpiece Support:** Workpiece kickback can occur with violent force if workpiece is not properly supported during operation. Always sand with workpiece firmly against table or another support device.

**Sanding Dust:** Sanding creates large amounts of dust that can lead to eye injury or respiratory illness. Reduce your risk by always wearing approved eye and respiratory protection when using sander. Never operate without adequate dust collection system in place and running. However, dust collection is not a substitute for using a respirator.

**Workpiece Inspection:** Nails, staples, knots, or other imperfections in workpiece can be dislodged and thrown from sander at a high rate of speed at people, or cause damage to sandpaper or sander. Never sand stock that has embedded foreign objects or questionable imperfections.

**Sandpaper Condition:** Worn or damaged sandpaper can fly apart and throw debris at operator, or aggressively grab workpiece, resulting in subsequent injuries from operator loss of workpiece control. Always inspect sandpaper before operation and replace if worn or damaged.

**Workpiece Integrity:** Sanding fragile workpieces can result in loss of control, resulting in abrasion injuries, impact injuries, or damage to sandpaper. Only sand solid workpieces that can withstand power sanding forces. Make sure workpiece shape is properly supported; avoid sanding workpieces without flat bottom surfaces unless some type of jig is used to maintain support and control when sanding force is applied.

## Preparation Overview

The purpose of the preparation section is to help you prepare your machine for operation. The list below outlines the basic process. Specific steps for each of these points will be covered in detail later in this section.

### The typical preparation process is as follows:

1. Unpack the machine and inventory the contents of the box/crate.
2. Clean the machine and its components.
3. Identify an acceptable location for the machine and move it to that location.
4. Level the machine with included leveling feet.
5. Assemble the loose components and make any necessary adjustments or inspections to ensure the machine is ready for operation.
6. Connect the machine to the power source.
7. Test run the machine to make sure it functions properly and is ready for operation.

### **WARNING**

**Serious injury could occur if you connect machine to power before completing setup process. DO NOT connect to power until instructed later in this manual.**

## Required for Setup

The items listed below are required to successfully set up and prepare this machine for operation.

### For Lifting

- Additional person to help lift machine.

### For Power Connection

- A power source that meets the minimum circuit requirements for this machine. (Refer to the **Power Supply Requirements** section for details.)

### For Assembly

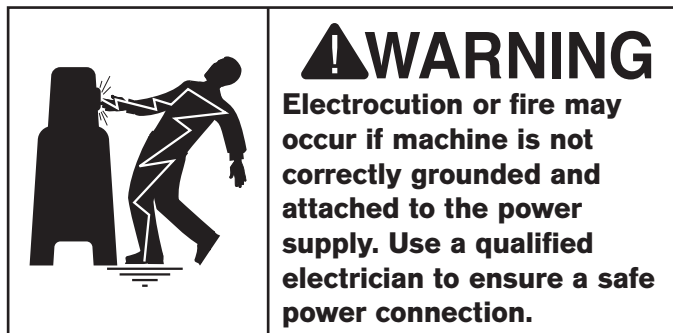
- Safety Glasses for Each Person
- Level
- Phillips Screwdriver #2
- Combination Wrenches 10mm, 17mm
- Hex Wrench 8mm
- 4" x 4" x 12" Wood Block
- Dust Hose 4" (length as needed)
- Hose Clamp 4"
- Dust Collection System

# Power Supply Requirements

## Availability

Before installing the machine, consider the availability and proximity of the required power supply circuit. If an existing circuit does not meet the requirements for this machine, a new circuit must be installed.

To minimize the risk of electrocution, fire, or equipment damage, installation work and electrical wiring must be done by an electrician or qualified service personnel in accordance with applicable electrical codes and safety standards.



## Full-Load Current Rating

The full-load current rating is the amperage a machine draws at 100% of the rated output power. On machines with multiple motors, this is the amperage drawn by the largest motor or sum of all motors and electrical devices that might operate at one time during normal operations.

**Full-Load Rating at 115V ..... 14 Amps**

**Full-Load Rating at 230V ..... 7 Amps**

The full-load current is not the maximum amount of amps that the machine will draw. If the machine is overloaded, it will draw additional amps beyond the full-load rating.

If the machine is overloaded for a sufficient length of time, damage, overheating, or fire may result—especially if connected to an undersized circuit. To reduce the risk of these hazards, avoid overloading the machine during operation and make sure it is connected to a power supply circuit that meets the requirements in the following section.

## Circuit Information

A power supply circuit includes all electrical equipment between the main breaker box or fuse panel in your building and the incoming power connections inside the machine. This circuit must be safely sized to handle the full-load current that may be drawn from the machine for an extended period of time. (If this machine is connected to a circuit protected by fuses, use a time delay fuse marked D.)

### **CAUTION**

**For your own safety and protection of property, consult an electrician if you are unsure about wiring practices or applicable electrical codes.**

**Note:** The circuit requirements in this manual are for a dedicated circuit—where only one machine will be running at a time. If this machine will be connected to a shared circuit where multiple machines will be running at the same time, consult a qualified electrician to ensure the circuit is properly sized.

## Circuit Requirements for 115V

This machine is prewired to operate on a power supply circuit that has verified ground and meets the following requirements:

**Nominal Voltage ..... 110V, 115V, 120V**  
**Cycle ..... 60 Hz**  
**Phase ..... Single-Phase**  
**Circuit Rating ..... 15 Amps**  
**Plug/Receptacle (included) ..... NEMA 5-15**

## Circuit Requirements for 230V

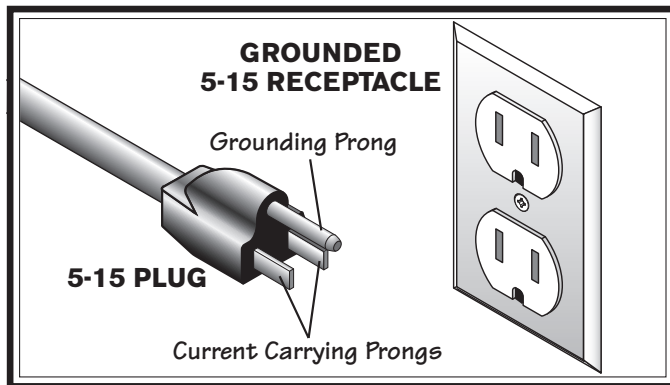
This machine can be converted to operate on a power supply circuit that has verified ground and meets the requirements listed below. (Refer to **Voltage Conversion** instructions for details).

**Nominal Voltage ..... 208V, 220V, 230V, 240V**  
**Cycle ..... 60 Hz**  
**Phase ..... Single-Phase**  
**Circuit Rating ..... 15 Amps**  
**Plug/Receptacle ..... NEMA 6-15**

## Grounding Requirements

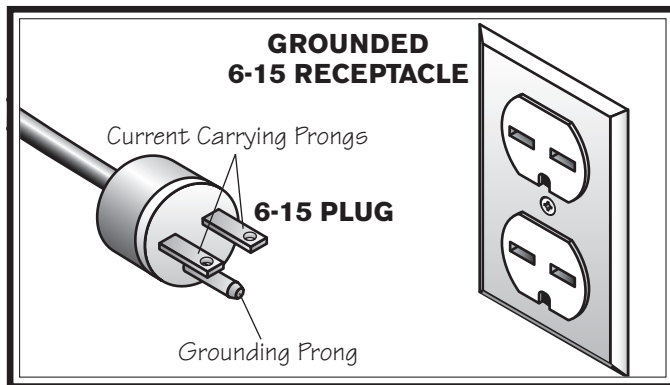
This machine must be grounded! In the event of certain types of malfunctions or breakdowns, grounding provides a path of least resistance for electric current in order to reduce the risk of electric shock.

**For 115V operation:** This machine is equipped with a power cord that has an equipment-grounding wire and a grounding plug (similar to the figure below). The plug must only be inserted into a matching receptacle (outlet) that is properly installed and grounded in accordance with all local codes and ordinances.



**Figure 6. NEMA 5-15 plug and receptacle.**

**For 230V operation:** The plug specified under "Circuit Requirements for 230V" on the previous page has a grounding prong that must be attached to the equipment-grounding wire inside the power cord. The plug must only be inserted into a matching receptacle (see following figure) that is properly installed and grounded in accordance with all local codes and ordinances.



**Figure 7. NEMA 6-15 plug and receptacle.**

## **!WARNING**

**Serious injury could occur if you connect the machine to power before completing the setup process. DO NOT connect to power until instructed later in this manual.**

Improper connection of the equipment-grounding wire can result in a risk of electric shock. The wire with green insulation (with or without yellow stripes) is the equipment-grounding wire. If repair or replacement of the power cord or plug is necessary, do not connect the equipment-grounding wire to a live (current carrying) terminal.

Check with an electrician or qualified service personnel if you do not understand these grounding requirements, or if you are in doubt about whether the tool is properly grounded.

If you ever notice that a cord or plug is damaged or worn, disconnect it from power, and immediately replace it with a new one.

## Extension Cords

We do not recommend using an extension cord with this machine. If you must use one, only use it if absolutely necessary and only on a temporary basis.

Extension cords cause voltage drop, which may damage electrical components and shorten motor life. Voltage drop increases as the extension cord size gets longer and the gauge size gets smaller (higher gauge numbers indicate smaller sizes).

Any extension cord used with this machine must contain a ground wire, match the required plug and receptacle listed in the **Circuit Requirements** for the applicable voltage, and meet the following requirements:

- Minimum Gauge Size.....12 AWG**
- Maximum Length (Shorter is Better) ....50 ft.**

# Converting Voltage to 230V

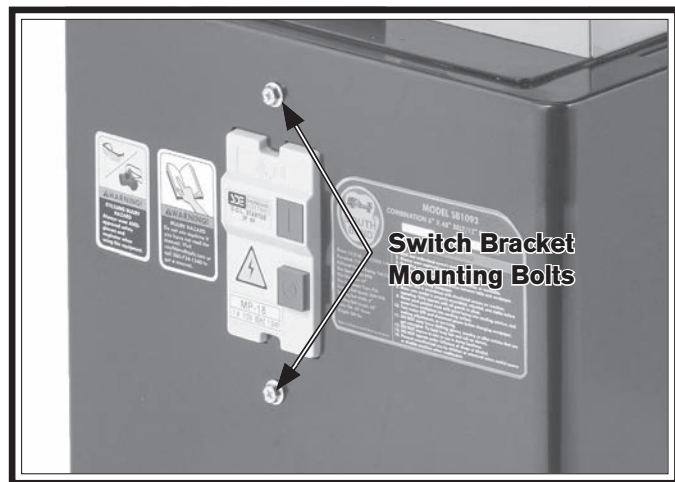
The voltage conversion procedure consists of replacing the magnetic switch, rewiring the motor, and installing the correct plug. The voltage conversion **MUST** be performed by an electrician or qualified service personnel.

**IMPORTANT:** *If the diagram included on the motor conflicts with this one, the motor may have changed since the manual was printed. Use the diagram provided on the motor junction box instead.*

Items Needed	Qty
Phillips Head Screwdriver #2.....	1
Electrical Tape .....	As Needed
Wire Nut (14 AWG).....	1
Wire Cutter/Stripper.....	1
230V Magnetic Switch Assy (PSB1093216X).....	1
6-15 Plug.....	1

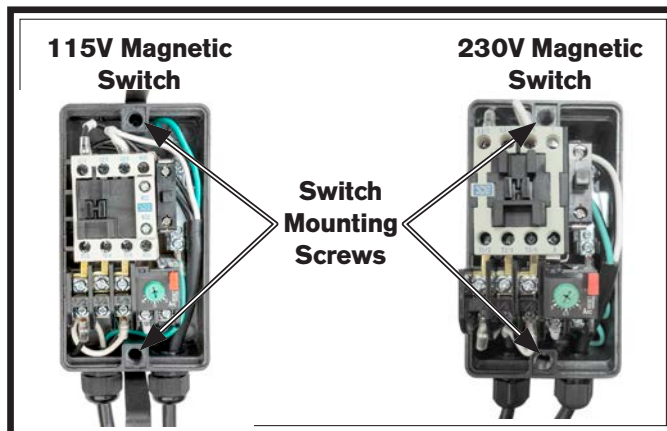
**To convert to 230V:**

1. DISCONNECT MACHINE FROM POWER!
2. Cut off existing 5-15 plug.
3. Remove (2) M8-1.25 x 20 flange bolts located above and below the power switch, remove switch from inside cabinet (see **Figure 8**).



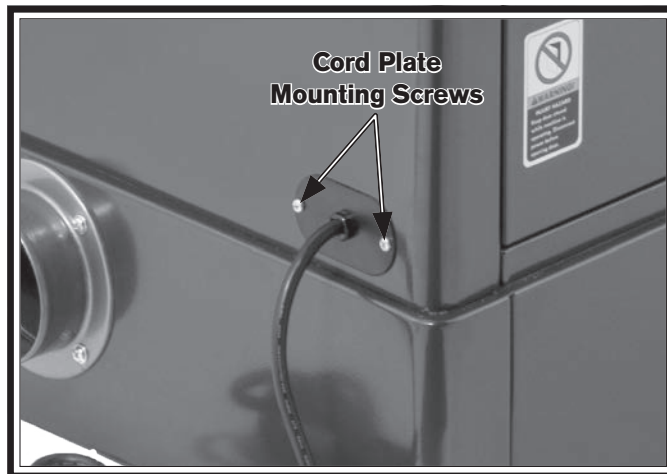
**Figure 8. Magnetic switch mounting bolts.**

4. Remove (2) M4-.7 x 10 Phillips head screws and separate magnetic switch from mounting bracket (see **Figure 9**).



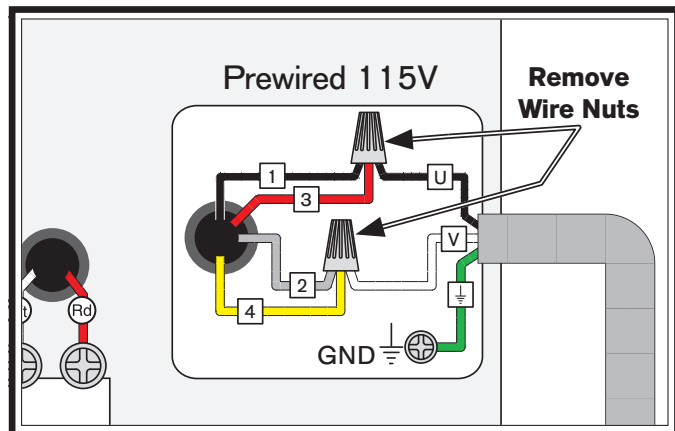
**Figure 9. Magnetic switch assembly.**

5. Remove (2) M5-.8 x 12 Phillips head screws from power cord plate, then feed plate and power cord through opening into cabinet (see **Figure 10**).



**Figure 10. Power cord plate.**

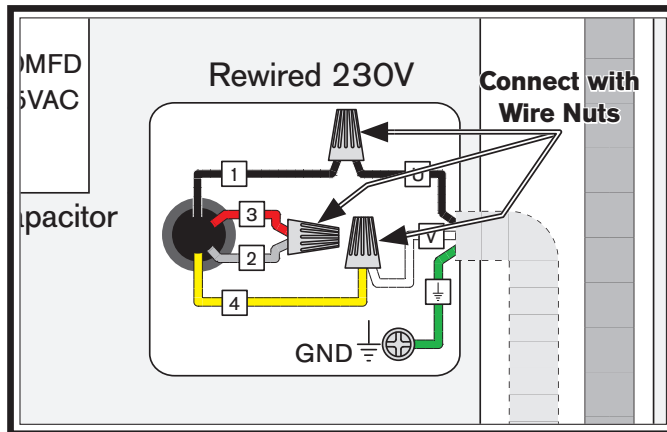
6. Open motor junction box, remove two wire nuts shown in **Figure 11**, then disconnect wires and remove 115V switch assembly.



**Figure 11. Inside motor junction box (pre-wired to 115V).**

7. Refer to wiring diagram on **Page 41** to verify 230V switch wiring.
8. Attach mounting bracket to 230V magnetic switch using (2) Phillips head screws from **Step 4**.
9. Install switch bracket to cabinet using (2) flange bolts from **Step 3**.
10. Feed new power cord through opening and secure power cord plate using (2) Phillips head screws from **Step 5**.

11. Use wire nuts to connect wires as indicated in **Figure 12**. Twist wire nuts onto their respective wires and wrap them with electrical tape so they will not come loose.



**Figure 12. Motor rewired to 230V.**

12. Close and secure motor junction box.
13. Install NEMA 6-15 plug according to manufacturer's instructions.



# Unpacking

This item was carefully packaged to prevent damage during transport. If you discover any damage, please immediately call Customer Service at (360) 734-1540 for advice. You may need to file a freight claim, so save the containers and all packing materials for possible inspection by the carrier or its agent.

# Inventory

<b>Crate (Figure 13)</b>	<b>Qty</b>
<b>A. Sander Body</b> .....	1

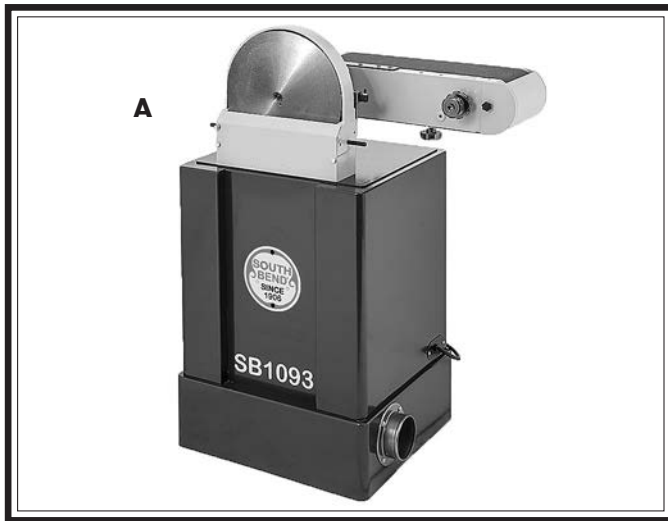


Figure 13. Sander unit.

## NOTICE

If you cannot find an item on this list, carefully check around/inside the machine and packaging materials. Often, these items get lost in packaging materials while unpacking or they are pre-installed at the factory.

<b>Assembly Components (Figure 14)</b>	<b>Qty</b>
<b>B.</b> Disc Sanding Table .....	1
<b>C.</b> Belt Sanding Table/Fence.....	1
<b>D.</b> Dust Port 4" .....	1
<b>E.</b> Belt Sander Back Stop.....	1
<b>F.</b> Miter Gauge .....	1
<b>G.</b> Sanding Disc 12" (Not Shown) .....	1

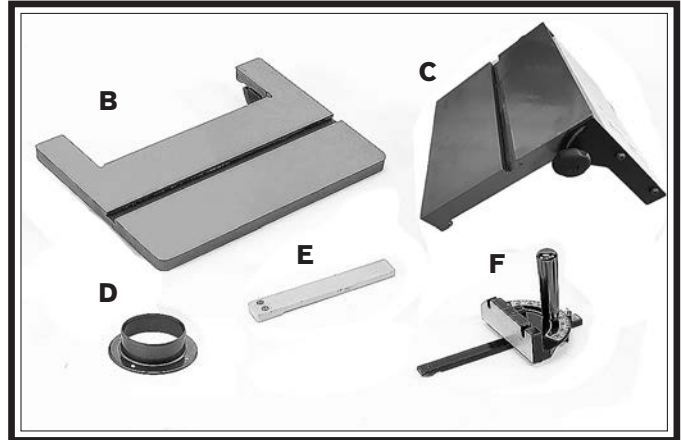


Figure 14. Assembly components.

<b>Hardware Bag (Figure 15)</b>	<b>Qty</b>
<b>H.</b> Cap Screws M10-1.5 x 30 (Fence/Table) .....	2
<b>I.</b> Fender Washers 10mm (Fence/Table) .....	2
<b>J.</b> Hex Bolts M6-1 x 20 (Back Stop) .....	2
<b>K.</b> Lock Washers 6mm (Back Stop) .....	2
<b>L.</b> Flange Screws M6-1 x 12 (Dust Port) .....	4
<b>M.</b> Leveling Feet M12-1.75 x 20 .....	4
<b>N.</b> Flat Washers 12mm.....	8
<b>O.</b> Hex Nuts M12-1.75 .....	8

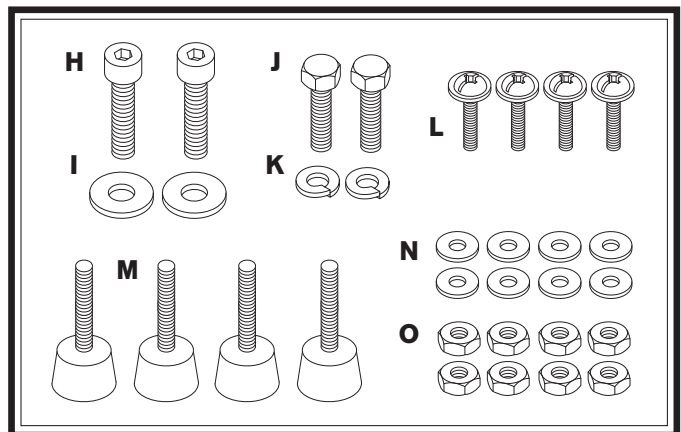


Figure 15. Hardware bag contents.

## Cleaning & Protecting

The unpainted surfaces are coated at the factory with a heavy-duty rust preventative that prevents corrosion during shipment and storage. The benefit of this rust preventative is that it works very well. The downside is that it can be time-consuming to thoroughly remove.

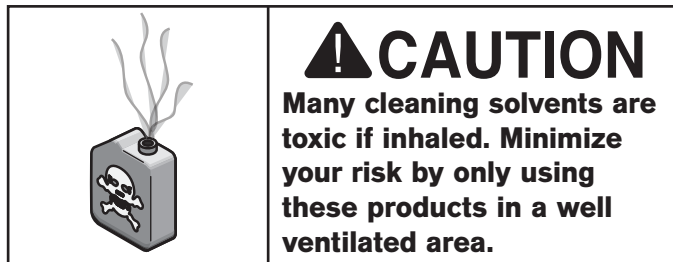
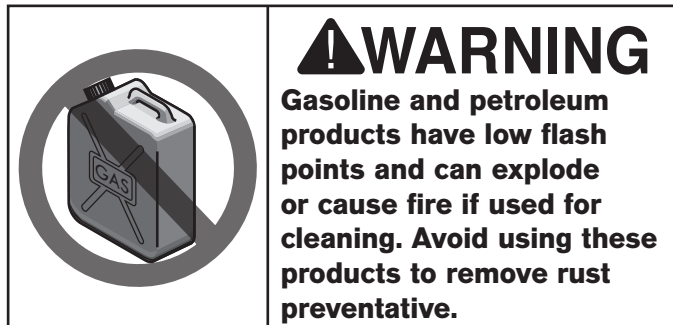
Be patient and do a careful job when cleaning and removing the rust preventative. The time you spend doing this will reward you with smooth-sliding parts and a better appreciation for the proper care of the unpainted surfaces.

Although there are many ways to successfully remove the rust preventative, the following process works well in most situations.

### Before cleaning, gather the following:

- Disposable rags
- Cleaner/degreaser (certain citrus-based degreasers work extremely well and they have non-toxic fumes)
- Safety glasses & disposable gloves

**Note:** Automotive degreasers, mineral spirits, or WD•40 can be used to remove rust preventative. Before using these products, though, test them on an inconspicuous area of a painted surface to make sure they will not damage it.



## NOTICE

**Avoid chlorine-based solvents, such as acetone or brake parts cleaner that may damage painted surfaces. Always follow the manufacturer's instructions when using any type of cleaning product.**

### Basic steps for removing rust preventative:

1. Put on safety glasses and disposable gloves.
2. Coat all surfaces that have rust preventative with a liberal amount of your cleaner or degreaser and let them soak for a few minutes.
3. Wipe off the surfaces. If your cleaner or degreaser is effective, the rust preventative will wipe off easily.

**Note:** To clean off thick coats of rust preventative on flat surfaces, such as beds or tables, use a PLASTIC paint scraper to scrape off the majority of the coating before wiping it off with your rag. (Do not use a metal scraper or it may scratch the surface.)

4. Repeat **Steps 2–3** as necessary until clean, then coat all unpainted surfaces with a quality metal protectant or light oil to prevent rust.

### T23692—Orange Power Degreaser

A great product for removing the waxy shipping grease from the *non-painted* parts of the machine during clean up.



Figure 16. T23692 Orange Power Degreaser.

## Location

### Physical Environment

The physical environment where your machine is operated is important for safe operation and longevity of parts. For best results, operate this machine in a dry environment that is free from excessive moisture, hazardous or flammable chemicals, airborne abrasives, or extreme conditions. Extreme conditions for this type of machinery are generally those where the ambient temperature is outside the range of 41°–104°F; the relative humidity is outside the range of 20–95% (non-condensing); or the environment is subject to vibration, shocks, or bumps.

### Electrical Installation

Place this machine near an existing power source. Make sure all power cords are protected from traffic, material handling, moisture, chemicals, or other hazards. Make sure to leave access to a means of disconnecting the power source or engaging a lockout/tagout device.

### Lighting

Lighting around the machine must be adequate enough to perform operations safely. Shadows, glare, or strobe effects that may distract or impede the operator must be eliminated.

### Weight Load

Refer to the **Machine Specifications** for the weight of your machine. Make sure that the surface upon which the machine is placed will bear the weight of the machine, additional equipment that may be installed on the machine, and the heaviest workpiece that will be used. Additionally, consider the weight of the operator and any dynamic loading that may occur when operating the machine.

### Space Allocation

Consider the largest size of workpiece that will be processed through this machine and provide enough space around the machine for adequate operator material handling or the installation of auxiliary equipment. With permanent installations, leave enough space around the machine to open or remove doors/covers as required by the maintenance and service described in this manual.

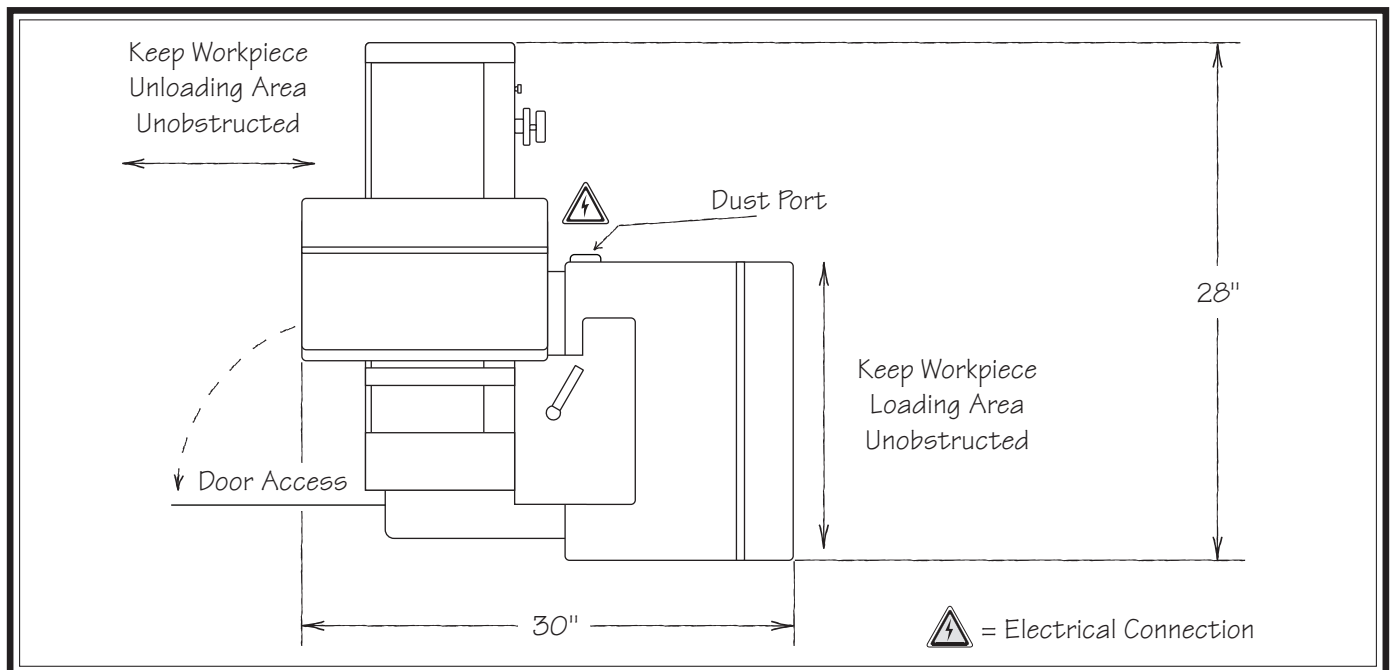
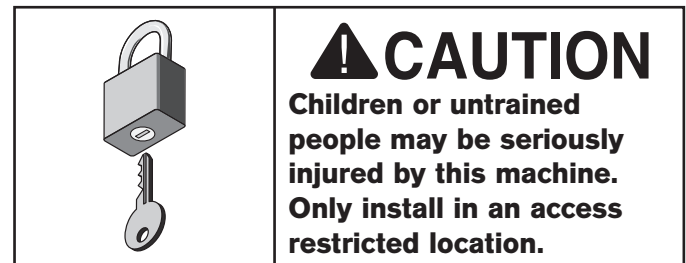


Figure 17. Minimum working clearances.

## Assembly

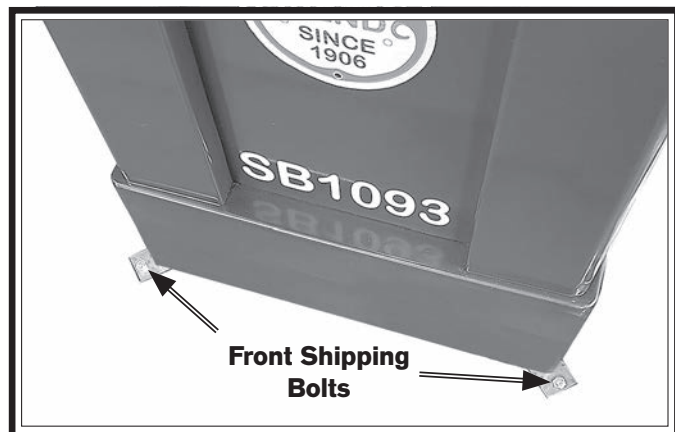
This machine must be fully assembled before it can be operated. Before beginning the assembly process, refer to **Required for Setup** on **Page 10** and gather all listed items. To ensure the assembly process goes smoothly, first clean any parts that are covered or coated in heavy-duty rust preventative (if applicable).



Review the **Power Supply** section on **Page 11**, then prepare a location for the sander.

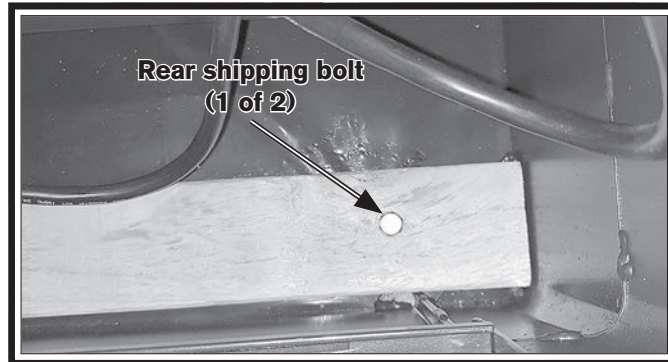
### To assemble sander:

1. Remove and inventory all contents from packaging.
2. Remove hex bolts and clips securing sander to front of pallet (see **Figure 18**).



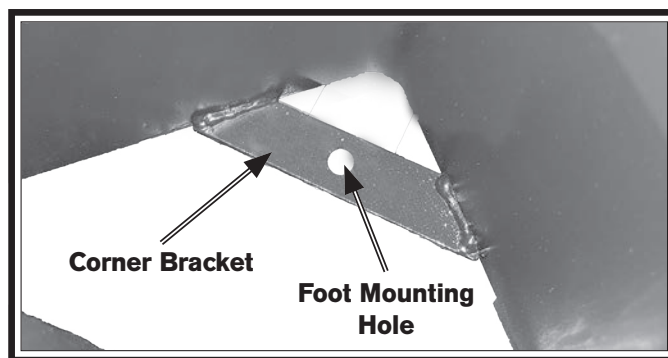
**Figure 18. Front shipping bolt locations.**

3. Open rear access door, then remove hex bolts and wood securing sander to rear of pallet (see **Figure 19**).

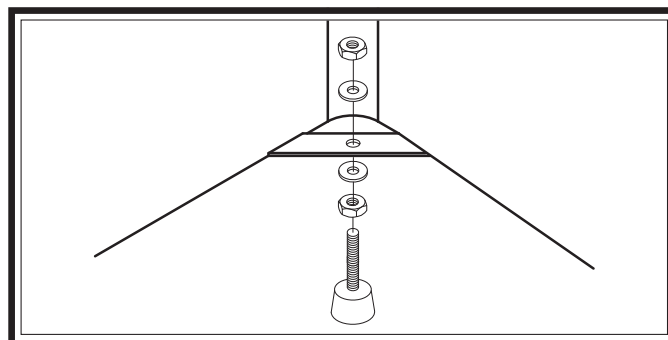


**Figure 19. Rear shipping bolts.**

4. Lift machine off of pallet and set on a protected surface.
  5. Tip machine to one side and place 4" x 4" wood block under side of machine.
- Note:** Have an assistant support machine from falling over during this procedure.
6. Install (1) leveling foot, (2) 12mm flat washers, and (2) M12-1.75 hex nuts to each corner bracket inside cabinet (see **Figures 20-21**).

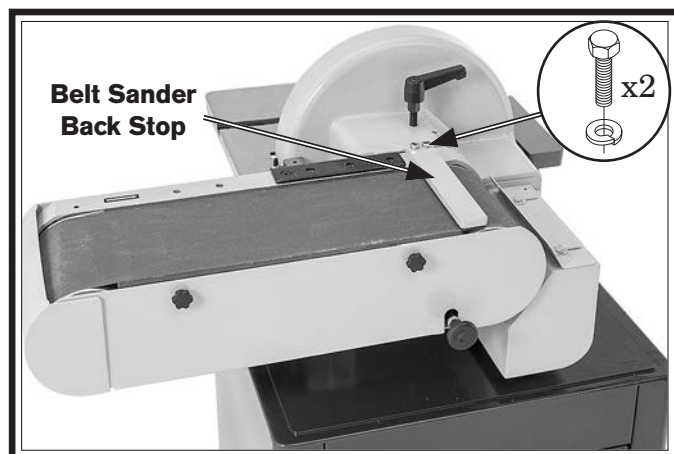


**Figure 20. Corner bracket for leveling foot.**



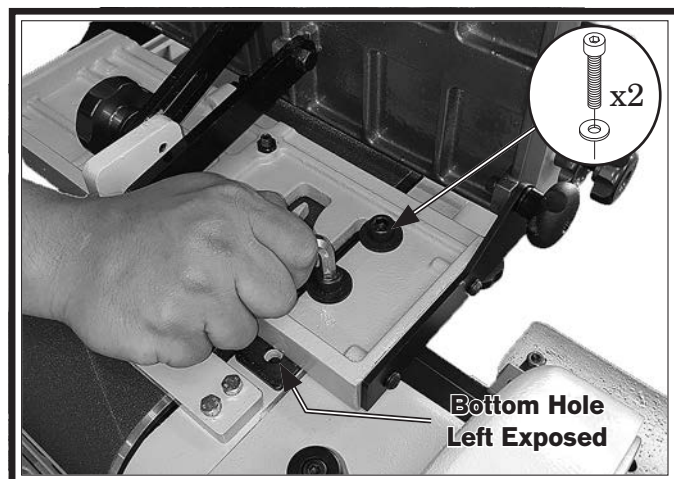
**Figure 21. Example of foot installation.**

7. Remove wood block, then tip machine to other side, place block under machine, and repeat **Step 6** to install remaining (2) leveling feet.
8. Place machine in desired location and level using feet adjustment nuts.
9. Place back stop across belt sander and align with two bottom holes, then attach using (2) M6-1 x 20 hex bolts and (2) 6mm lock washers as shown in **Figure 22**.



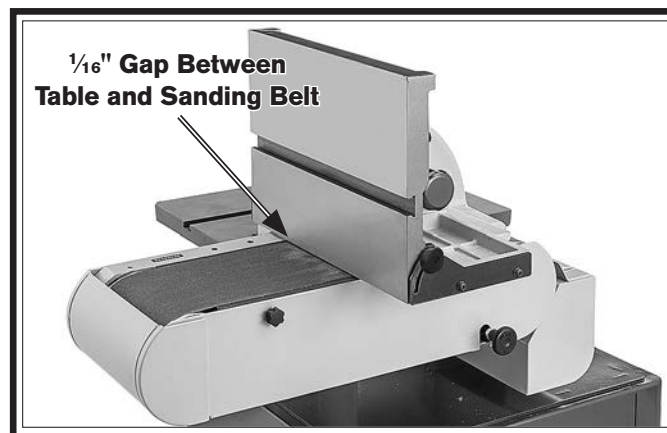
**Figure 22. Belt Sander back stop.**

10. Lay table/fence assembly on belt sander and align slots with second and third holes in mounting spacer plate, leaving bottom hole exposed and secure with (2) M10-1.5 x 25 cap screws and (2) 10mm fender washers (see **Figure 23**).



**Figure 23. Mounting table/fence assembly.**

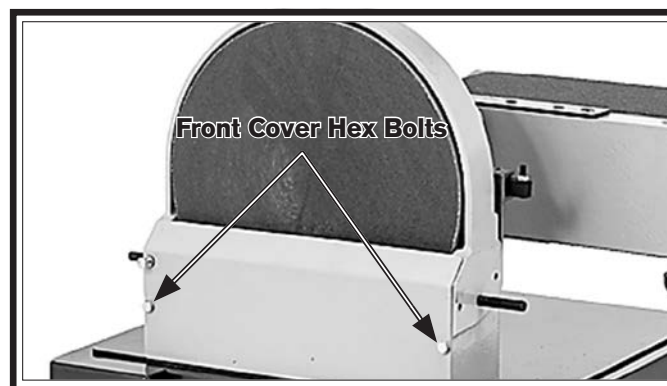
**Note:** Make sure the gap between the table and sanding belt is no more than  $\frac{1}{16}$ ". Loosen table lock knobs and adjust as necessary (see **Figure 24**).



**Figure 24. Belt sander table/fence gap.**

11. Loosen (2) hex bolts on front cover of disc sander (see **Figure 25**).

**Note:** Loosening hex bolts will allow easier access to install sanding disc. **DO NOT** remove bolts.

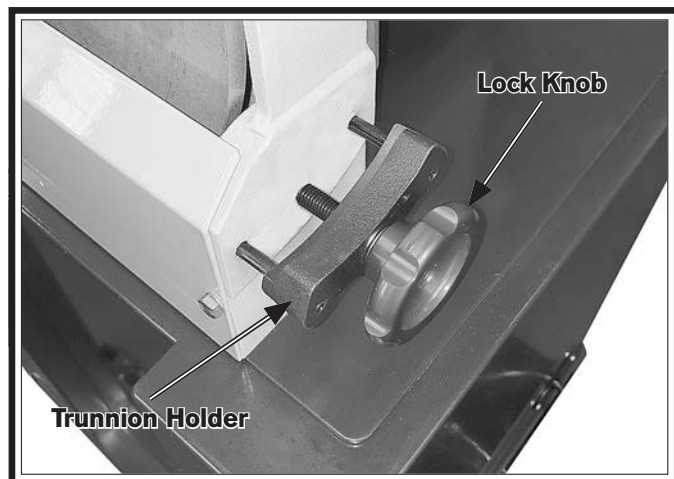


**Figure 25. Disc sander cover.**

12. Carefully peel protective backing half way from back of sanding disc.
13. Slide half of sanding disc (that still has backing) down behind front plate and line top of sanding disc with top of aluminum disc.
14. Gently press disc adhesive to disc.
15. Rotate disc 180°, then pull remainder of protective backing off disc.

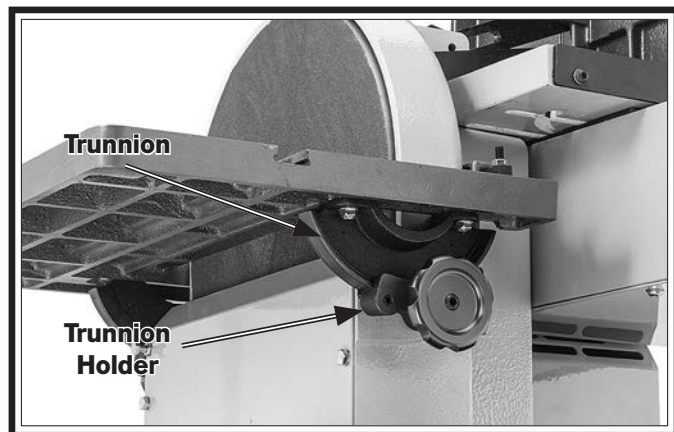
16. Firmly press sanding disc against aluminum disc to ensure it is secure.
17. Tighten front cover hex bolts.
18. Loosen disc sanding table lock knobs and thread to end of studs, then pull trunnion holders out away from sander body (see **Figure 26**).

**Note:** DO NOT remove lock knobs.



**Figure 26.** Trunnion holders.

19. Place disc sander table trunnions into trunnion holders, slide trunnion holders in against table trunnions, then tighten knobs (see **Figure 27**).



**Figure 27.** Disc sander table installed.

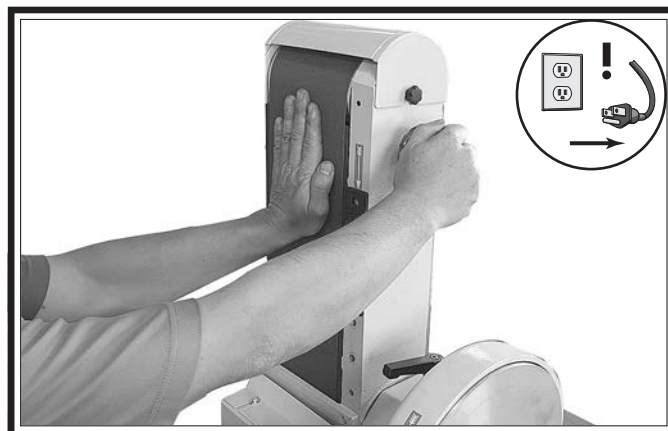
20. Loosen tilt lock lever, pull indexing pin, and stand belt sander to vertical position, then tighten tilt lock lever.

21. Tension sanding belt by turning tension knob clockwise until belt is stiff.

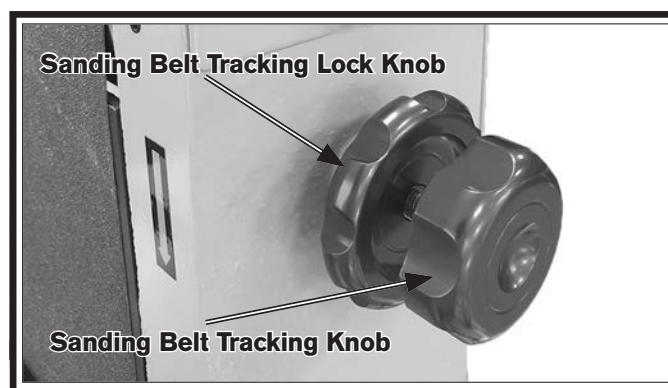
**Note:** Over-tensioning sanding belt will cause it to stretch and become weak, shortening the lifespan of the sanding belt.

22. Check sanding belt tracking by hand by pulling down on belt. Sanding belt should remain at center of drums. If necessary, adjust tracking by first, loosening tracking lock knob, then turning tracking knob left or right until sanding belt remains at center of drums (see **Figures 28–29**).

**Note:** For more information on sanding belt tracking, refer to **Tracking Sanding Belt** on **Page 31**.

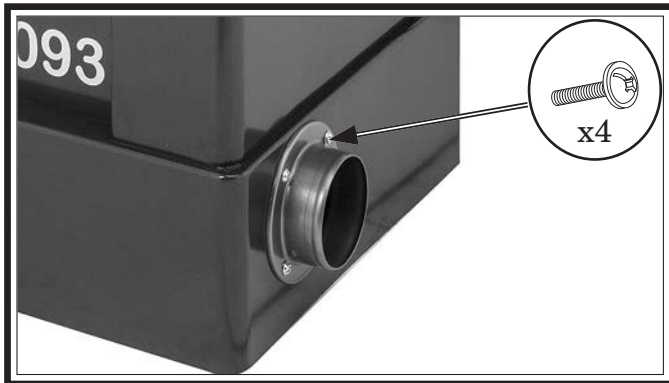


**Figure 28.** Hand tracking sanding belt.



**Figure 29.** Sanding belt tracking knob.

23. Tighten tracking lock knob.
24. Install dust port using (4) M6-1 x 12 flange screws (see **Figure 30**).



**Figure 30.** Dust port installed on cabinet.

## Dust Collection

### ⚠ CAUTION

This machine creates a lot of wood chips/ dust during operation. Breathing airborne dust on a regular basis can result in permanent respiratory illness. Reduce your risk by wearing a respirator and capturing the dust with a dust-collection system.

#### Recommended CFM at Dust Port: 400 CFM

*Do not confuse this CFM recommendation with the rating of the dust collector. To determine the CFM at the dust port, you must consider these variables: (1) CFM rating of the dust collector, (2) hose type and length between the dust collector and the machine, (3) number of branches or wyes, and (4) amount of other open lines throughout the system. Explaining how to calculate these variables is beyond the scope of this manual. Consult an expert or purchase a good dust collection "how-to" book.*

#### To connect sander to a dust collector:

1. Fit a 4" dust hose connected to a dust collector over dust port and secure in place with hose clamp.
2. Tug hose to make sure it does not come off.

**Note:** *A tight fit is necessary and ensures proper performance during operation.*

## Test Run

After all preparation steps have been completed, the machine and its safety features must be tested to ensure correct operation. If you discover a problem with the operation of the machine or its safety components, do not operate it further until you have resolved the problem.

**Note:** Refer to **Troubleshooting** on **Page 38** for solutions to common problems that may occur. If you need additional help, contact our Tech Support at (360) 734-1540.

The test run consists of verifying the following:

- Motor powers up and runs correctly.
- Magnetic switch control works correctly.

### **WARNING**

**Serious injury or death can result from using this machine BEFORE understanding its controls and related safety information. DO NOT operate, or allow others to operate, machine until the information is understood.**

### **WARNING**

**DO NOT start machine until all preceding setup instructions have been performed. Operating an improperly set up machine may result in malfunction or unexpected results that can lead to serious injury, death, or machine/property damage.**

### To test run machine:

1. Clear away all tools and objects used during preparation and assembly.
2. Connect machine to power source.
3. Press green Start button to turn machine **ON**.

**Note:** Keep an eye on the belt tracking when first starting the machine. If the belt immediately tracks to one side or the other, turn the machine off, **DISCONNECT POWER** and repeat **Step 22** in **Assembly**. Follow steps in **Tracking Sanding Belt** on **Page 31** to fine tune belt tracking adjustments.

— When operating properly, machine runs smoothly with little or no vibration or rubbing noises. If machine is operating correctly, the test run is complete.

— Investigate and correct strange or unusual noises or vibrations before operating machine further. **ALWAYS** disconnect machine from power when investigating or correcting potential problems.

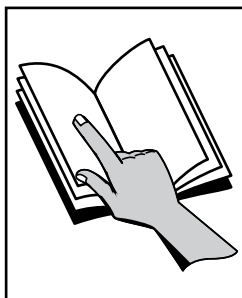
4. Press red OFF button to turn machine **OFF**. Congratulations, the test run is complete!



## Operation Overview

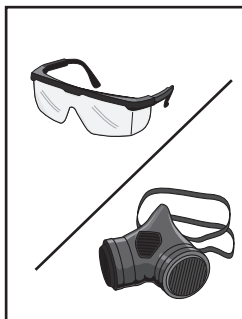
The purpose of this overview is to provide the novice machine operator with a basic understanding of how the machine is used during operation, so they can more easily understand the controls discussed later in this manual.

**Note:** Due to the generic nature of this overview, it is not intended to be an instructional guide for performing actual machine operations. To learn more about specific operations and machining techniques, seek training from people experienced with this type of machine, and do additional research outside of this manual by reading "how-to" books, trade magazines, or websites.



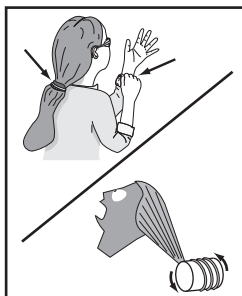
### **!WARNING**

To reduce the risk of serious injury when using this machine, read and understand this entire manual before beginning any operations.



### **!WARNING**

To reduce risk of eye injury from flying chips or lung damage from breathing dust, always wear safety glasses and a respirator when operating this machine.



### **!WARNING**

Keep hair, clothing, and jewelry away from moving parts at all times. Entanglement can result in death, amputation, or severe crushing injuries!

To complete a typical operation, the operator does the following:

1. Examines the workpiece to make sure it is suitable for sanding.
2. Determines which sanding grit to use and installs belt/disc.
3. Adjusts table tilt and/or fence position to desired location.
4. Secures loose clothing, removes loose jewelry, and ties back long hair.
5. Puts on safety glasses, respirator and any other required protective equipment.
6. Starts sander and dust collector.
7. Holds workpiece firmly against table and miter gauge (if used), pushes workpiece into sanding belt or along down-spin of sanding disc, and moves workpiece back and forth to wear sandpaper evenly and prevent overheating.
8. Stops sander.

## Sanding Tips

- Replace the sandpaper with a higher grit to achieve a finer finish.
- Extend the life of the sandpaper by regularly using PRO-STIK® abrasive belt cleaners (see **Accessories on Page 33**).
- When sanding workpieces with a bow or crown, place the high point up on the table to prevent the workpiece from rocking.
- Hold workpiece securely with both hands. Use work table to support workpiece.
- Sanding discs/belts clog and wear. Change sandpaper whenever you notice a difference in sanding quality/performance.
- To increase the life of the sanding disc/belt and ensure even wear, move the workpiece back and forth across the sanding surface.

## Choosing Sandpaper

The Model SB1093 uses a 6" x 48" sanding belt and a 12" sanding disc.

There are many types of sanding belts and discs to choose from. We recommend aluminum oxide for general workshop environments. Below is a chart that groups abrasives into different classes, and shows which grits fall into each class.

Grit	Class	Usage
36	Extra Coarse	Rough sawn boards, thickness sanding, and glue removal.
60	Coarse	Thickness sanding and glue removal.
80–100	Medium	Removing marks and initial finish sanding.
120–180	Fine	Finish sanding.

The general rule of thumb is to sand a workpiece with progressively higher grit numbers, with no one grit increase of more than 50 grits at a time. Avoid skipping grits; the larger the grit increase, the harder it will be to remove the scratches from the previous grit.

Ultimately, the type of wood you use and your stage of finish will determine the best grit types to install on your sander.

### WARNING

**Sanding surfaces can cause serious personal injury if they come in contact with fingers, hands or other body parts. Use extreme care to provide a safe distance between the belt and any part of your body.**

## Stock Inspection and Requirements

Some workpieces are not safe or may require modification before they are safe to sand.

**Before sanding, inspect all workpieces for the following:**

- **Material Type:** This machine is intended for ONLY sanding natural and man-made wood products. This machine is NOT designed to sand metal, glass, stone, tile, drywall or cementitious backerboard.
- **Foreign Objects:** Nails, staples, dirt, rocks and other foreign objects are often embedded in wood. While sanding, these objects can become dislodged and tear the sanding belt. Always visually inspect your workpiece for these items. If they can't be removed, DO NOT sand the workpiece.
- **Excessive Glue or Finish:** Sanding workpieces with excess glue or finish will load up the abrasive, reducing its usefulness and lifespan.

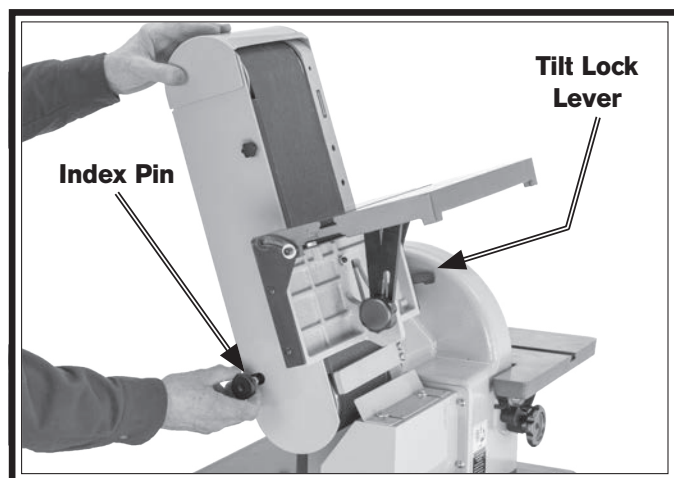
## Horizontal Sanding

If the belt sander is in the vertical position, follow the steps, "To set up sander for horizontal sanding" below, to set up the sander for horizontal sanding. If the sander is already in the horizontal position, skip ahead to "To perform horizontal or edge sanding" on **Page 26**.

### Setting Up Sander For Horizontal Sanding

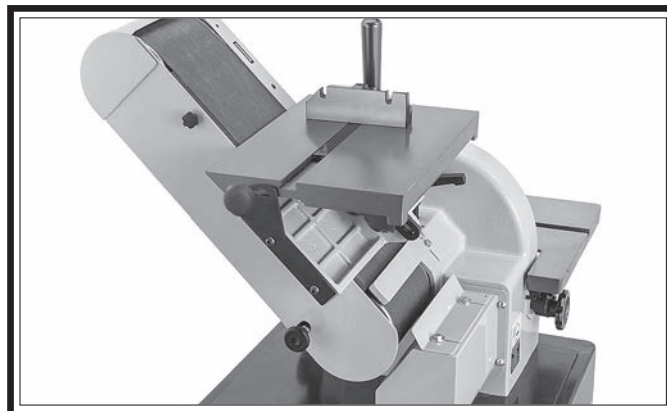
1. DISCONNECT MACHINE FROM POWER!
2. Loosen belt sander lock lever by turning clockwise, then pull indexing pin out and carefully tilt belt sander to desired position; tighten tilt lock lever (see **Figure 31**).

**Note:** The indexing pin will snap into locked position at 45°. Simply pull the indexing pin back out to continue tilting to 90°.



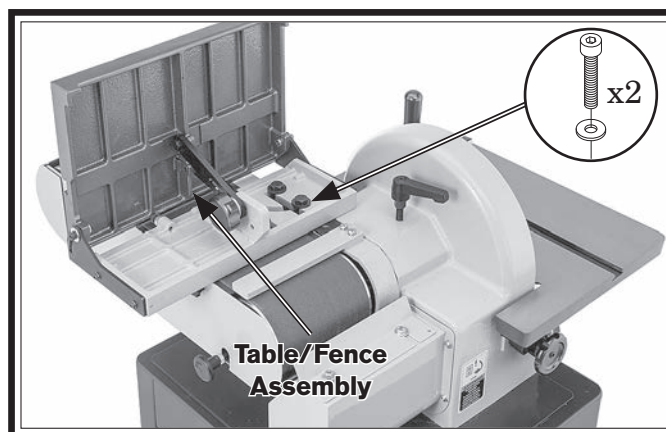
**Figure 31. Tilting belt sander.**

**Note:** To use the belt sander in the 45° position, leave the indexing pin engaged at 45° point and tighten the tilt lock lever. Loosen the tilt lock knob to adjust the table if necessary (see **Figure 32**).



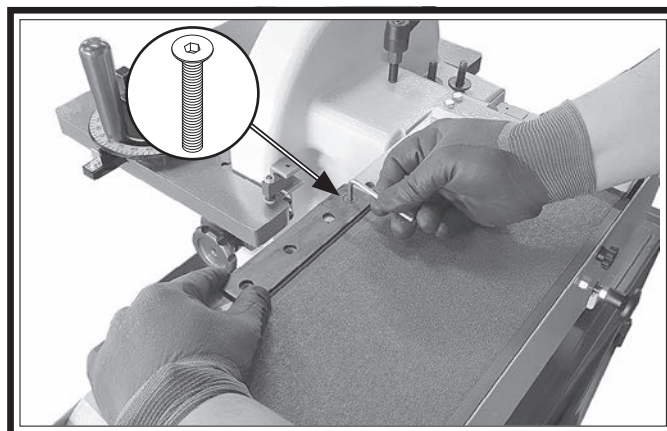
**Figure 32. Belt sander in 45° position.**

3. Remove (2) cap screws and (2) washers and remove table assembly (see **Figure 33**).



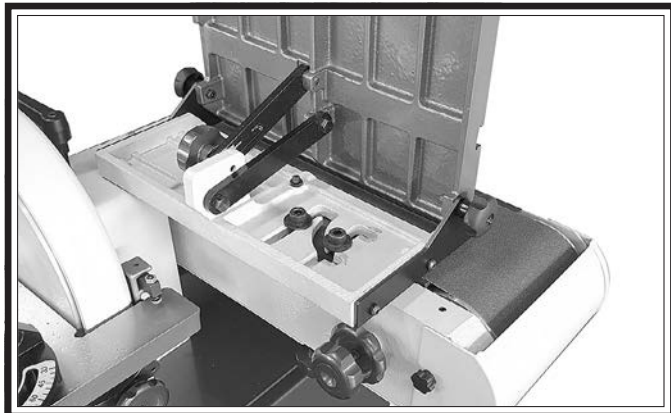
**Figure 33. Table assembly mounting screws.**

4. Loosen table/fence spacer plate and rotate 180° to align with upper holes; re-tighten spacer plate (see **Figure 34**).



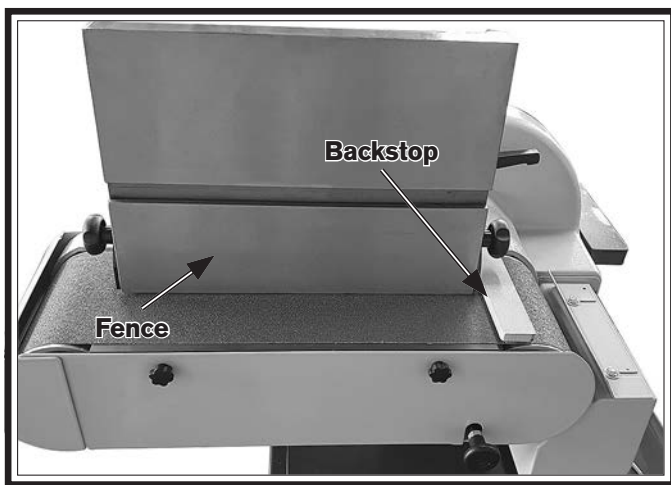
**Figure 34. Rotating spacer plate.**

- Position table/fence assembly over spacer plate and re-install mounting bolts and washers (see **Figure 35**).



**Figure 35. Fence mounting position.**

- Position fence in desired position, then tighten mounting screws (see **Figure 36**).



**Figure 36. Fence installed.**

**Note:** The back stop is intended to keep the workpiece from being thrown from the belt. It may be removed for longer work pieces and to perform 'through-sanding' operations however, the back stop should immediately be re-installed after this type of operation.

## Performing Horizontal Edge Sanding

- DISCONNECT MACHINE FROM POWER!
- Make sure sanding belt is tensioned correctly (see **Tensioning Sanding Belt** on Page 30).

- Make sure belt tracking is correctly set (see **Tracking Sanding Belt** on Page 31).
- Adjust angles of fence, if necessary, for operation.
- Turn sander and dust collector **ON**.
- Place workpiece firmly against fence.
- Slowly move workpiece into sanding belt.
- While holding back end of workpiece against backstop and fence with both hands, and while keeping your fingers away from belt, slowly feed workpiece into belt, as shown in **Figures 37–38**.

**Note:** The belt sander can also be used with the fence removed however, the back stop must remain installed.



**Figure 37. Example of sanding face of workpiece in horizontal position.**



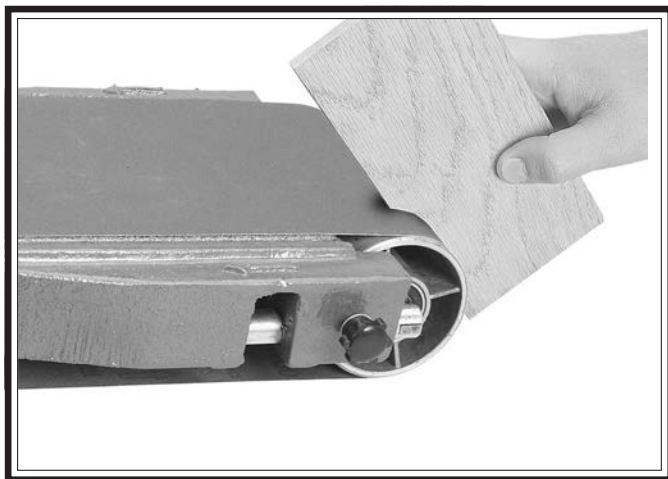
**Figure 38. Example of sanding edge of workpiece in horizontal position.**

## Contour Sanding

Contour sanding can be done by opening the end guard and using the end of the sanding belt.

### To perform contour sanding:

1. DISCONNECT MACHINE FROM POWER!
2. Place belt sander in horizontal position (see **Page 25** for instructions).
3. Make sure the sanding belt is tensioned correctly (see **Tensioning Sanding Belt on Page 30**).
4. Make sure belt tracking is correctly set (see **Tracking Belt on Page 31**).
5. Loosen knob that secures end guard and swing guard open.
6. Turn the sander *ON*.
7. Slowly feed workpiece into curved end of belt and continue moving workpiece profile along contour until you achieve desired shape, as shown in **Figure 39**.



**Figure 39. Example of contour sanding.**

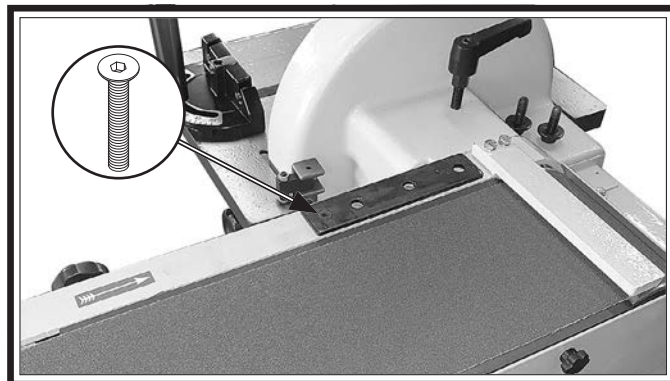
8. When finished contour sanding, close and secure end guard.

## Vertical Sanding

If the belt sander is in the horizontal position, proceed to, "To set up sander for vertical sanding" below, to set up the sander for vertical sanding. If the sander is already in the vertical position, skip ahead to "To perform vertical sanding" on **Page 28**.

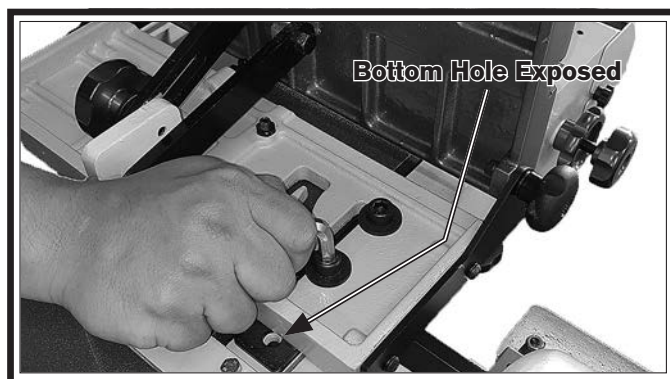
### Setting Up Sander For Vertical Sanding

1. DISCONNECT MACHINE FROM POWER!
2. Remove fence mounting bolts, flat washers and fence assembly.
3. Loosen table/fence spacer connecting screw and rotate spacer plate 180° to line up with lower mounting holes, then tighten screw (see **Figure 40**).



**Figure 40. Fence spacer in lower position.**

4. Lay table/fence assembly on belt sander and align slots with holes in mounting spacer plate, leaving bottom hole exposed, then install mounting bolts and washers (see **Figure 41**).



**Figure 41. Mounting table assembly.**

- Loosen tilt lock lever, pull indexing pin and stand belt sander to vertical position, then tighten tilt lock lever.

**Note:** Make sure the gap between the table and sanding belt is no more than  $\frac{1}{16}$ ". Loosen table lock knobs and adjust as necessary (see *Figure 42*).

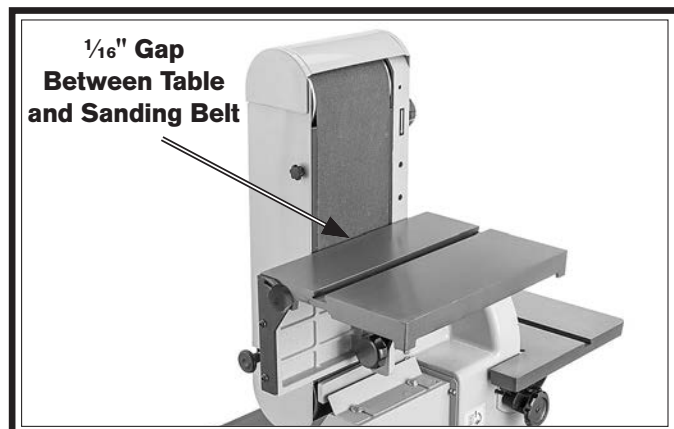


Figure 42. Proper sander table gap.

## **! WARNING**

Do not operate this equipment when wearing loose clothing, gloves, neckties, rings, bracelets or other jewelry that might get caught in the moving belt. Serious personal injury may result. You must re-install the idler roller and sleeve guard before performing edge or horizontal sanding operations.

## Performing Vertical Sanding

- Make sure the sanding belt is tensioned correctly (see **Tensioning Sanding Belt** on **Page 30**).
- Make sure belt tracking is correctly set (see **Tracking Sanding Belt** on **Page 31**).
- Adjust angles of work table and miter gauge for operation.
- Turn sander and dust collector *ON*.
- Place workpiece on table and firmly against the miter gauge.

- Slowly and with light pressure, move workpiece into sanding belt. See **Figures 43–45** for examples of vertical belt sanding.



Figure 43. Example of end grain sanding.

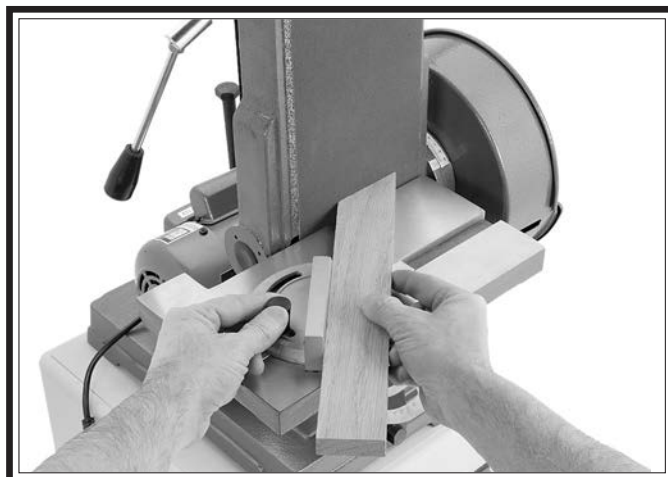


Figure 44. Example of vertical miter sanding.

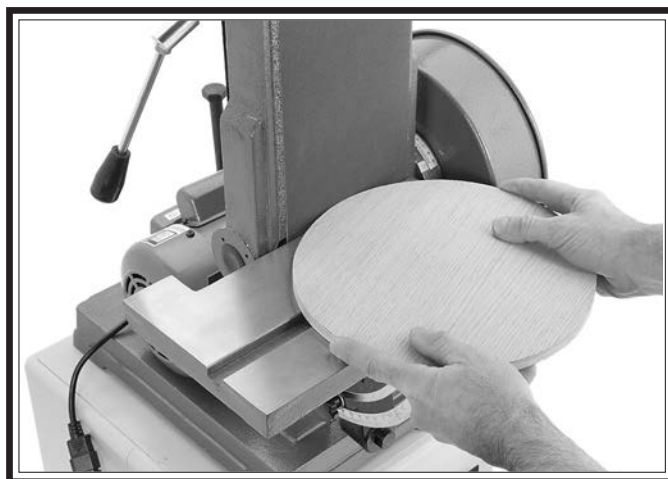


Figure 45. Example of sanding round workpiece in vertical position.

## Disc Sanding

The sanding disc can be used to create flat, smooth ends and edges of workpieces.

### **⚠ CAUTION**

Always keep the workpiece on the left side of the wheel that rotates down toward the work table. This will keep the workpiece from flying out of your hands due to kickback.

### **⚠ CAUTION**

To reduce the risk of your fingers getting trapped between the work table and sanding disc, make sure the table is approximately  $\frac{1}{16}$ " away from the sanding disc.

#### To use sanding disc:

1. DISCONNECT MACHINE FROM POWER!
2. Adjust angles of work table and miter gauge for operation.
3. Connect sander to power, turn it **ON**, and allow it to reach full speed.
4. Place workpiece on the work table and firmly against the miter gauge.
5. With light pressure, slowly move workpiece into the left side of the sanding disc. See **Figures 46–49** for examples of disc sanding.

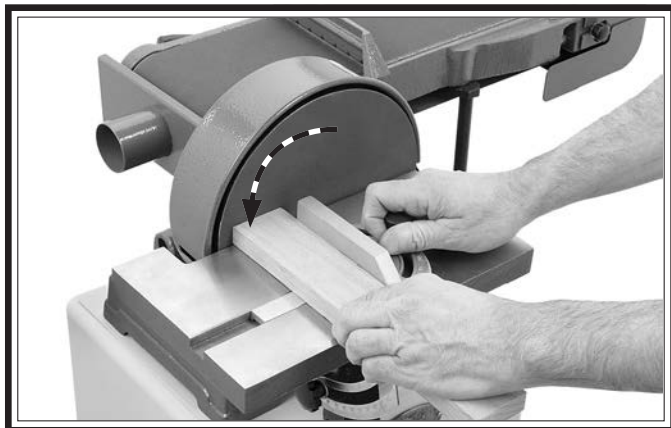


Figure 46. Example of 90° disc sanding.



Figure 47. Example of miter sanding.

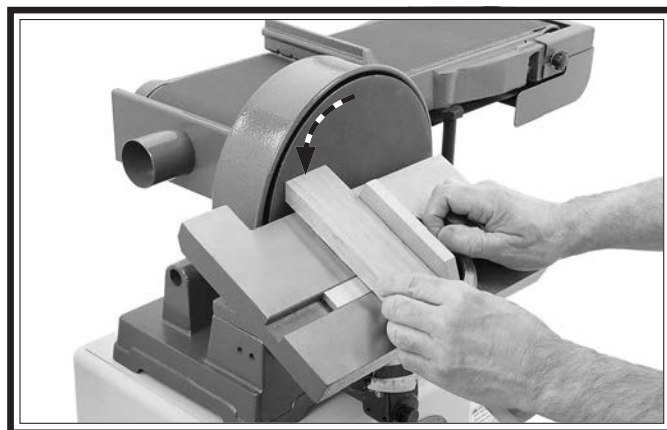


Figure 48. Example of angle sanding.

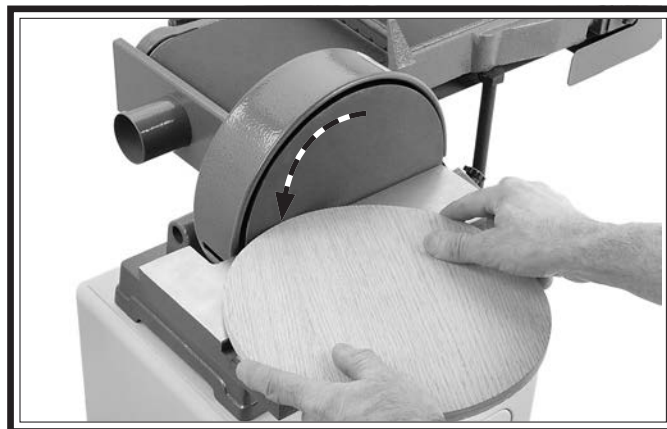


Figure 49. Example of sanding round workpiece.

**Note:** To prevent burning the workpiece and overloading the sanding disc, move the workpiece slowly back and forth from the left side of the sanding disc to the center.

## Changing Sanding Belt

Some sanding belts are designed to sand in only one direction and will have a direction indicated on the back of the belt. The Model SB1093 is designed so that the sanding belt travels clockwise as viewed from the side.

### To change sanding belt:

1. DISCONNECT MACHINE FROM POWER!
2. Loosen end guard lock knob and swing end guard open.
3. Remove side cover by unscrewing (2) lock knobs (see **Figure 50**).
4. Loosen belt tension knob (see **Figure 50**) until sanding belt is loose and slides freely back and forth.

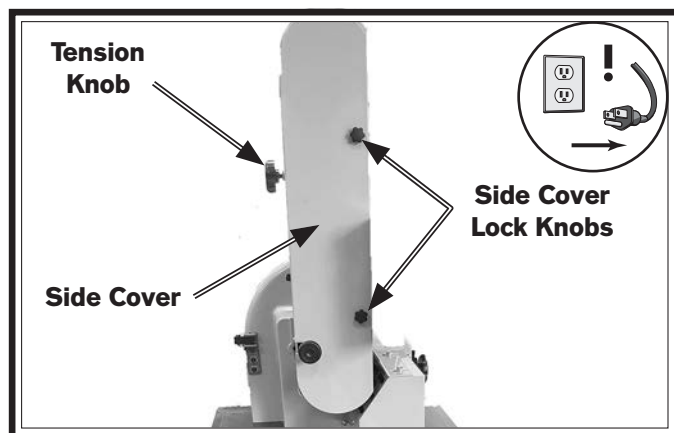


Figure 50. Sanding belt access components.

5. Remove belt from rollers and sanding belt frame (see **Figure 51**).

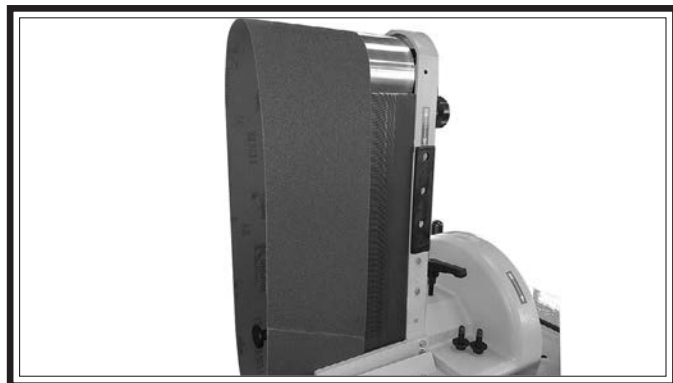


Figure 51. Example of removing sanding belt.

6. Slide new sanding belt over rollers and position at center.
7. Follow steps for **Tensioning Sanding Belt** on **This Page** and **Tracking Sanding Belt** on **Page 31**.
8. Re-install side cover and close end guard.

## Tensioning Sanding Belt

Sanding belt tension will change over time as the sanding belt wears and the user tends to apply more pressure during usage. A belt that is not tensioned properly becomes inefficient, wanders back and forth, or creates excessive wear on your machine.

Optimal settings for sanding belt tension often change, so use this as a guide to help determine the right belt tension.

### Symptoms of low belt tension:

**Tracking Problems:** A loose belt will tend to wander to one side and/or the other. This may also be a sign of a worn/stretched belt in which case, it may be time to replace it.

**Belt Slippage:** If you notice the belt slipping during operation or the printing on the back of the belt is highly worn, this is likely a sign that your belt is loose.

### Symptoms of high belt tension:

**Tracking Problems:** A belt that is too tight will also cause tracking problems, although the belt will usually tend to track to one side, not wander back and forth.

**Machine Stops Quickly:** When properly tensioned, the machine will turn a few revolutions after the power has been turned off. If your machine stops quickly after being turned off, this may be a sign of a sanding belt that is too tight.

**Belt Wears Prematurely:** An over-tensioned sanding belt will stretch and become weak, shortening the lifespan of the belt.



**To adjust sanding belt tension:**

1. Turn sanding belt tension knob clockwise to tighten sanding belt; turn counter-clockwise to loosen. Tension sanding belt by turning tension knob (see **Figure 52**) until belt is stiff.

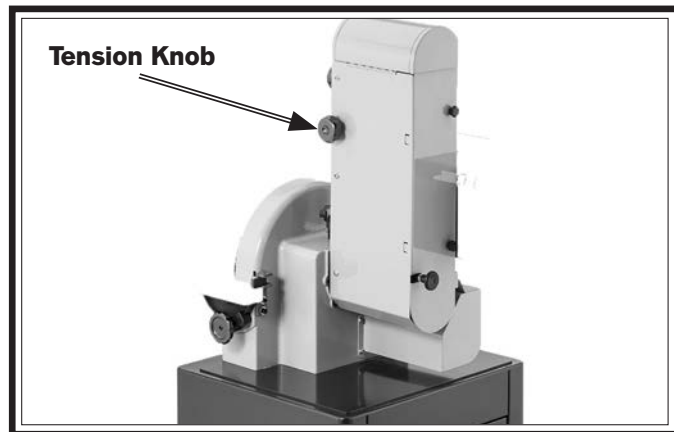


Figure 52. Sanding belt tension knob.

2. Continue to **Tracking Sanding Belt**.

**Tracking Sanding Belt**

The aim of tracking the belt is to keep it centered on the rollers.

**Tracking Belt**

1. DISCONNECT MACHINE FROM POWER!
2. Make sure sanding belt is properly tensioned (see **Tensioning Sanding Belt** on **Page 30**).
3. Rotate sanding belt by hand while watching belt alignment on rollers (see **Figure 53**). Belt should stay in center of roller.

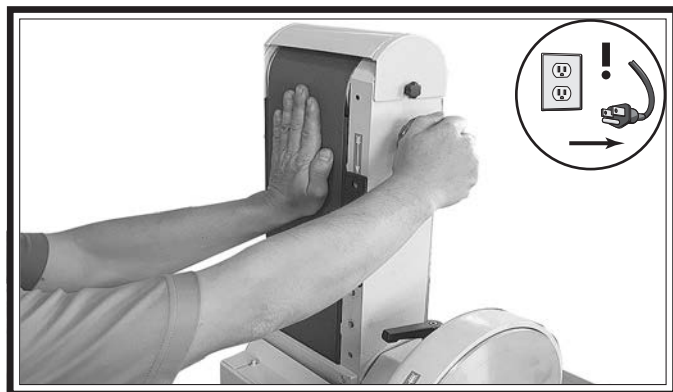


Figure 53. Hand tracking sanding belt.

— If sanding belt stays in center of rollers as you rotate belt by hand, proceed to "Fine tuning belt tracking".

— If the sanding belt *does not* stay in the center of the rollers, continue to **Step 4**.

4. Loosen belt tracking lock knob, then turn tracking knob counter-clockwise to move belt *left*, turn tracking knob clockwise to move belt *right* (see **Figure 54**).

**Note:** After hand tracking is complete, continue to "**Fine tuning belt tracking**".

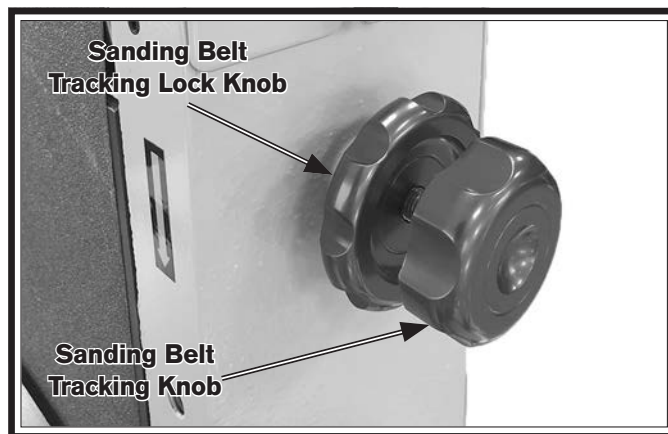


Figure 54. Sanding belt tracking and lock knob.

**Fine Tuning Belt Tracking**

1. Reconnect machine to power.
2. With one hand on belt tracking knob, press green ON button to start machine.
 

**Note:** Watch belt closely. If the belt jumps quickly to one side or the other, stop machine and repeat **Steps 1–4** in **Tracking Belt**.
3. With machine running, slowly turn tracking knob to move belt left or right until belt stays in center of rollers.
4. Tighten tracking lock knob.

# Changing Sanding Disc

The Model SB1093 accepts 12" diameter paper-backed pressure sensitive adhesive (PSA) discs (refer to **Accessories** on **Page 33**).

## Tools Needed

Wrench 10mm ..... 1

Qty

## To change sanding disc:

1. DISCONNECT MACHINE FROM POWER!

2. Loosen disc table tilt lock knobs and thread to end of studs.

**Note:** To avoid having the table suddenly drop, loosen lock knobs **BEFORE** moving 90° stop.

**IMPORTANT:** Do not remove lock knobs. Unscrew knobs to end of threaded stud to allow trunnion holders to be pulled away from sander body.

3. While holding table, rotate 90° stop, then carefully pull trunnion holders away from machine and remove work table (see **Figures 55–56**).

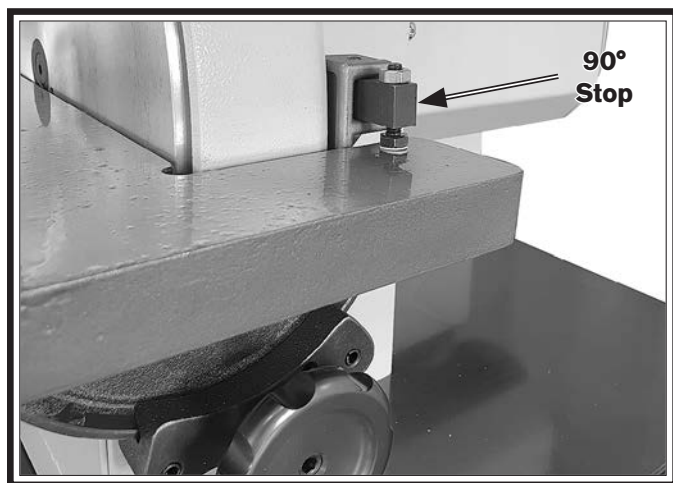


Figure 55. Disc table 90° stop.

4. Loosen (2) hex bolts and washers on front cover of disc sander, DO NOT remove cover. See **Figure 56** for component and fastener locations.

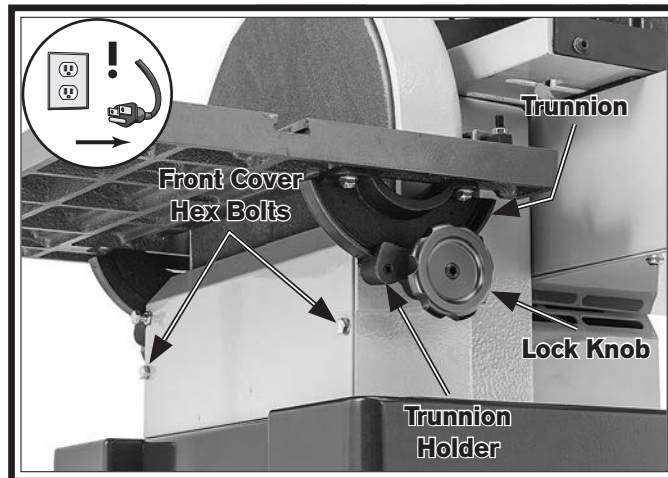


Figure 56. Disc sander table components.

5. Remove PSA sanding disc from aluminum plate.

6. Remove dried-on adhesive from aluminum plate using acetone or lacquer thinner and brush, then let it dry.

**CAUTION:** Follow the manufacturer's safety recommendations when using acetone or lacquer thinner.

7. Peel off backing from new PSA disc, then press it onto aluminum plate, working from center outward, making sure it contacts surface evenly.

8. Tighten front cover hex bolts loosened in **Step 4**.

9. Re-install work table and secure trunnions with lock knobs.

# Accessories

This section includes the most common accessories available for your machine through our exclusive dealer, Grizzly Industrial, Inc., at [grizzly.com](http://grizzly.com).

**⚠ WARNING**

**Installing unapproved accessories may cause machine to malfunction, resulting in serious personal injury or machine damage. To reduce this risk, only install accessories recommended by South Bend or Grizzly.**

**NOTICE**

**Refer to Grizzly's website or latest catalog for additional recommended accessories.**

**G0862—3 HP Portable Cyclone Dust Collector**  
 The G0862 features a 3 HP motor, a whopping 1941 CFM of airflow capacity, and a 35-gallon collection capacity. It's packed with features like a quick-release collection drum, latching system, high-efficiency, two-stage separation driven by a 15" cast-aluminum impeller, durable powder coated finish, and a heavy-duty steel frame and housing.



**Figure 57. Model G0862 3 HP Portable Cyclone Dust Collector.**

**12" PSA Aluminum Oxide Sanding Discs**  
 Our aluminum oxide sanding discs are manufactured in ISO 9002 factories to ensure the highest quality and are available in packs of two.

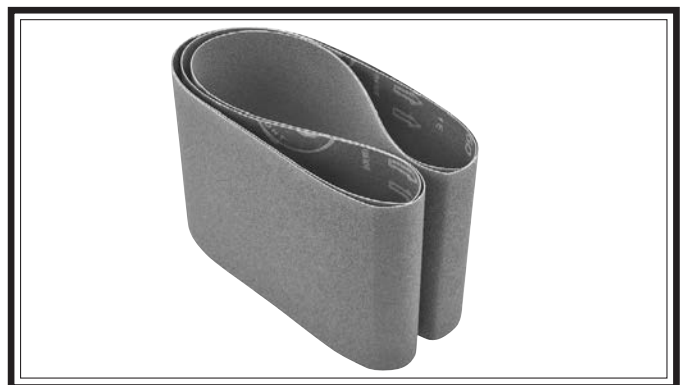
- D1335** ..... 60-Grit
- D1336** ..... 80-Grit
- D1337** ..... 100-Grit
- D1338** ..... 120-Grit
- D1339** ..... 150-Grit
- D1340** ..... 180-Grit
- D1341** ..... 220-Grit



**Figure 58. 12" sandpaper discs.**

**6" x 48" Aluminum Oxide Sanding Belts**  
 Our aluminum oxide sanding belts are sized right for all of your belt sanding needs and are sold in packs of 10.

- H3515** ..... 60-Grit
- H3516** ..... 80-Grit
- H3517** ..... 100-Grit
- H3518** ..... 120-Grit
- H3519** ..... 150-Grit
- H3520** ..... 180-Grit
- H3521** ..... 220-Grit



**Figure 59. Assortment of sanding belts.**

**order online at [www.grizzly.com](http://www.grizzly.com) or call 1-800-523-4777**

- G5562—SLIPIT® 1 Qt. Gel**
- G5563—SLIPIT® 12 Oz. Spray**
- G2870—Boeshield® T-9 4 Oz. Spray**
- G2871—Boeshield® T-9 12 Oz. Spray**
- H3788—G96® Gun Treatment 12 Oz. Spray**
- H3789—G96® Gun Treatment 4.5 Oz. Spray**



**Figure 60. Recommended products for protecting unpainted cast iron/steel parts on machinery.**

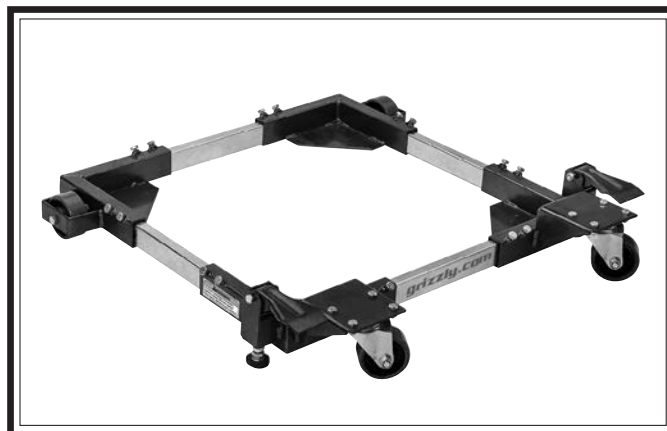
Wood dust has been linked to nasal cancer and severe respiratory illnesses. If you work around dust everyday, a half-mask respirator can be a lifesaver. Also compatible with safety glasses!

- H2499—Small Half-Mask Respirator**
- H3631—Medium Half-Mask Respirator**
- H3632—Large Half-Mask Respirator**
- H3635—Cartridge Filter Pair P100**



**Figure 61. Half-mask respirator with disposable cartridge filters.**

**T28922 Bear Crawl® "Cub" Mobile Base**  
 The Grizzly Bear Crawl Mobile Base is the end-product of years of customer input, product design and testing. We believe it to be the best Universal-Base system available. The Cub version of the Bear Crawl was designed for a wide variety of smaller footprint machines sized 14" x 14" to 22½" x 22½" weighing up to 900 lbs.



**Figure 62. T28922 Bear Crawl® mobile base.**

**PRO-STIK® Abrasive Surface Cleaners**  
 Extend the life of your sanding discs and sleeves! Choose the Pro-Stik® with a handle for greater control or without a handle for more usable area.

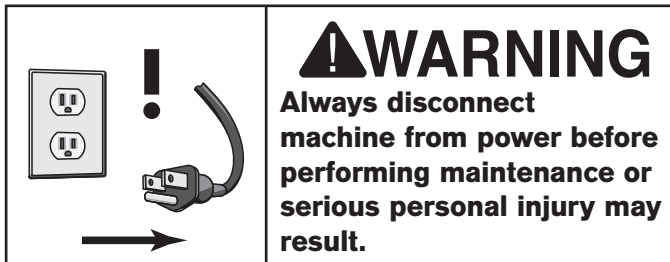
- W1306** ..... 1½" x 1½" x 8½"
- W1307** ..... 2" x 2" x 12"
- W1308** ..... 1½" x 1½" x 9" with Handle
- W1309** ..... 2" x 2" x 11" with Handle



**Figure 63. PRO-STIK® Abrasive Cleaners.**

**order online at [www.grizzly.com](http://www.grizzly.com) or call 1-800-523-4777**

## Maintenance Schedule Machine Storage



For optimum performance from your machine, follow this maintenance schedule and refer to any specific instructions given in this section.

### Ongoing

- Check/correct loose mounting bolts.
- Check/correct damaged or worn sanding belt/disc.
- Check/correct worn or damaged wires.
- Clean/protect table.
- Correct any other unsafe condition.

### Monthly

- Check for V-belt tension, damage, or wear.

## Cleaning & Protecting

Cleaning the Model SB1093 is relatively easy. Vacuum excess wood chips and sawdust, and wipe off the remaining dust with a dry cloth. If any resin has built up, use a resin dissolving cleaner to remove it.

Protect the unpainted cast iron table by wiping it clean after every use—this ensures moisture from wood dust does not remain on bare metal surfaces. Keep the table rust-free with regular applications of products like G96® Gun Treatment, SLIPIT®, or Boeshield® T-9. See **Accessories** beginning on **Page 33** for more information.

All machinery will develop serious rust problems and corrosion damage if it is not properly prepared for storage. If decommissioning this machine, use the steps in this section to ensure that it remains in good condition.

### To prepare machine for storage or decommission it from service:

1. Disconnect all power sources to machine.
2. Thoroughly clean all unpainted, bare metal surfaces, then coat them with light weight grease or rust preventative. Take care to ensure these surfaces are completely covered but that grease or rust preventative is kept off of painted surfaces.

**Note:** *If the machine will be out of service for only a short period of time, use way oil or a good grade of medium-weight machine oil (not auto engine oil) in place of the grease or rust preventative.*

3. Loosen or remove belt so it does not become stretched while machine is not in use.
4. Completely cover machine with tarp or plastic sheet that will keep out dust and resist liquid or moisture. If machine will be stored in/near direct sunlight, use cover that will block the sun's rays.

# Tensioning/Replacing V-Belt

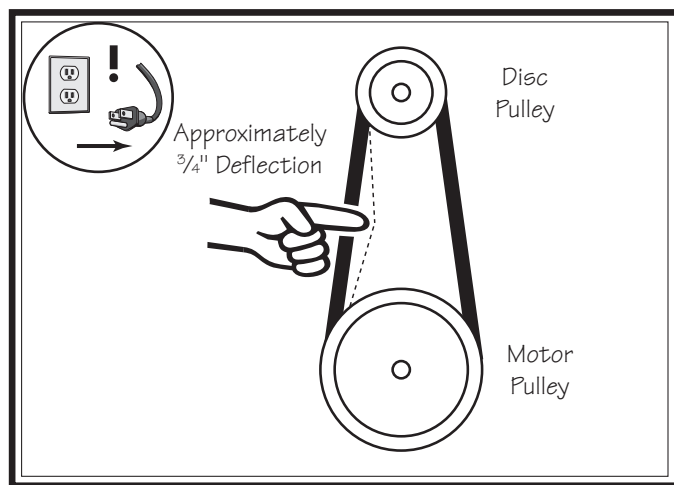
Maintaining proper V-belt tension is critical when it comes to machine operation. A belt that is too loose will result in excess heat, slippage and premature wear of the belt and pulleys. Too much tension can cause excess wear on the belt as well as damage to the bearings, and shafts.

**Note:** After the first 16 hours of operation with a new belt, check and re-tension the drive belt, as it may stretch and seat during this time, which will cause it to lose the initial tension that you set.

**Tools Needed** Qty  
 Wrench 10mm, 17mm..... 1

## Checking V-Belt Tension

1. DISCONNECT MACHINE FROM POWER!
2. Open rear access door.
3. Check V-belt tension by applying moderate pressure approximately mid-way between pulleys (see **Figure 64**).
  - If V-belt deflection is approximately 3/4", belt is correctly tensioned and no adjustment is necessary.
  - If deflection is not approximately 3/4", V-belt is not correctly tensioned. Follow steps to loosen or tighten V-belt.



**Figure 64. Proper belt tension.**

## Tightening V-belt

1. Loosen bottom nut on belt tensioning bolt (see **Figure 65**).



**Figure 65. Drive belt tensioning bolt.**

2. Turn top nut clockwise to lower motor.

**Note:** Check belt tension every couple of turns until proper tension is achieved. DO NOT over tighten belt. An over-tightened belt will cause the belt to wear prematurely and will also increase wear on the pulleys, shafts, and bearings.

3. Tighten both nuts against motor mounting plate.

## Loosening V-Belt

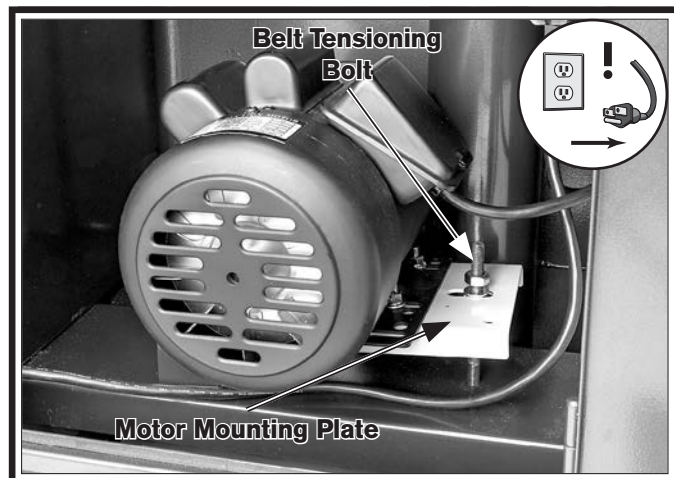
1. Loosen top nut on belt tensioning bolt (see **Figure 65**).

**Note:** Motor will raise with the tension of the belt. Check tension every couple of turns until proper tension is achieved. An under-tensioned belt may cause excessive heat and premature belt and pulley wear.

2. Tighten both nuts against motor mounting plate.

## Replacing V-Belt

1. DISCONNECT MACHINE FROM POWER!
2. Open rear access door.
3. Loosen top nut on belt tensioning bolt enough to raise motor and remove belt from motor pulley (see **Figure 66**).



**Figure 66.** Drive belt tensioning bolt.

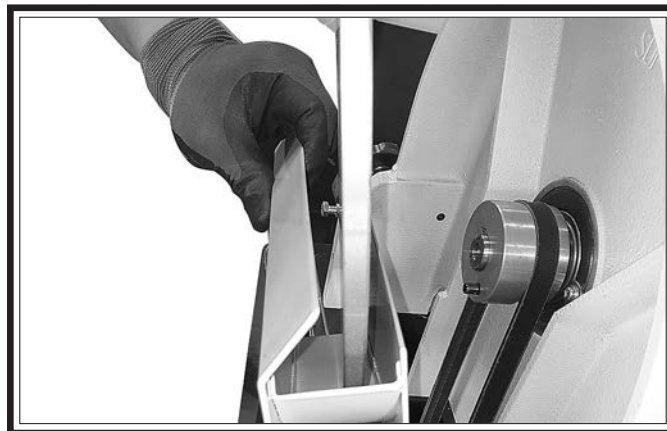
4. Follow **Steps 2–6 of Changing Sanding Disc on Page 32**.
5. While holding mounting disc, use 5mm hex wrench to loosen hex screw in center of disc, then remove screw (see **Figure 67**).



**Figure 67.** Removing disc mounting screw.

6. Remove (2) hex bolts and washers from front cover, then remove disc and front cover together, as shown in **Figure 68**.

**IMPORTANT:** *Aluminum disc and front cover must be removed together.*



**Figure 68.** Removing aluminum disc.

7. Follow **Steps 1–2 of Loosening V-Belt on Page 36**.
8. Roll belt off of motor pulley, then pull belt out from top of machine.
9. Feed new V-belt through top opening and set into disc pulley.
10. Lift motor enough to set belt into motor pulley.
11. Follow steps to tension V-belt located on **Page 36**.
12. Re-install aluminum disc and front cover tighten mounting screw.
13. Follow **Steps 7–9 of Changing Sanding Disc on Page 32**.

If you need replacement parts, or if you are unsure how to do any of the solutions given here, feel free to call us at (360) 734-1540.

Symptom	Possible Cause	Possible Solution
Machine does not start or a breaker trips.	<ol style="list-style-type: none"> <li>1. Incorrect power supply voltage or circuit size.</li> <li>2. Blown fuse/tripped circuit breaker at main panel.</li> <li>3. Plug/receptacle at fault/wired incorrectly.</li> <li>4. Thermal overload relay has tripped.</li> <li>5. Break or short in wiring; or loose connections.</li> <li>6. Motor ON/OFF switch at fault.</li> <li>7. Motor connection wired incorrectly.</li> <li>8. Start capacitor blown or at fault.</li> <li>9. Contactor not energized/has poor contacts.</li> <li>10. Centrifugal switch at fault.</li> <li>11. Motor at fault.</li> </ol>	<ol style="list-style-type: none"> <li>1. Ensure correct power supply voltage and circuit size.</li> <li>2. Correct the cause of overload, then reset/replace fuse or breaker.</li> <li>3. Test for good contacts; correct the wiring.</li> <li>4. Allow relay/motor to cool. If necessary, press reset button inside switch.</li> <li>5. Trace/replace broken or corroded wires; fix loose connections.</li> <li>6. Replace switch.</li> <li>7. Wire motor correctly (refer to inside junction box cover or manual).</li> <li>8. Replace start capacitor.</li> <li>9. Test all legs for power, test field coil and replace if at fault.</li> <li>10. Adjust/replace centrifugal switch.</li> <li>11. Test for shorted windings, bad bearings and repair or replace.</li> </ol>
Machine stalls or is underpowered.	<ol style="list-style-type: none"> <li>1. Too much pressure when feeding workpiece.</li> <li>2. Sanding belt in not tensioned properly.</li> <li>3. V-belt is worn or not tensioned properly.</li> <li>4. Belt slipping/pulleys misaligned.</li> <li>5. Plug/receptacle at fault.</li> <li>6. Pulley/sprocket slipping on shaft.</li> <li>7. Motor overheated, tripping machine circuit breaker.</li> <li>8. Run capacitor at fault.</li> <li>9. Motor bearings at fault.</li> <li>10. Centrifugal switch/contact points at fault.</li> <li>11. Motor at fault.</li> </ol>	<ol style="list-style-type: none"> <li>1. Reduce pressure when feeding workpiece.</li> <li>2. Check sanding belt tension. Re-tension sanding belt (<b>Page 30</b>).</li> <li>3. Inspect/replace/tension V-belt (<b>Page 36</b>).</li> <li>4. Tension/replace belt; ensure pulleys are aligned.</li> <li>5. Test for good contacts/correct wiring.</li> <li>6. Tighten/replace loose pulley/shaft.</li> <li>7. Clean motor/let cool, and reduce workload. Reset breaker.</li> <li>8. Test/repair/replace.</li> <li>9. Test/repair/replace.</li> <li>10. Adjust centrifugal switch/clean contact points. Replace either if at fault.</li> <li>11. Test/repair/replace.</li> </ol>



<b>Symptom</b>	<b>Possible Cause</b>	<b>Possible Solution</b>
Machine has excessive vibration or noise or noisy operation.	<ol style="list-style-type: none"> <li>1. Motor or component loose.</li> <li>2. Mobile base lock knobs loose or stand feet not adjusted properly.</li> <li>3. V-belt worn or not tensioned properly.</li> <li>4. Motor mount loose/broken.</li> <li>5. Sanding disc out of balance or loose.</li> <li>6. Motor fan rubbing on fan cover.</li> <li>7. Pulley loose or not in alignment; shaft bent.</li> <li>8. Motor bearings at fault.</li> </ol>	<ol style="list-style-type: none"> <li>1. Fix/replace fan cover; replace loose or damaged fan.</li> <li>2. Tighten mobile base lock knobs or adjust stand feet to stabilize machine.</li> <li>3. Inspect/replace/tension V-belt (<b>Page 36</b>).</li> <li>4. Tighten/replace.</li> <li>5. Tighten disc hub or replace disc.</li> <li>6. Fix/replace fan cover; replace loose/damaged fan.</li> <li>7. Replace worn pulley, key, and shaft, and realign.</li> <li>8. Test by rotating shaft; rotational grinding/loose shaft requires bearing replacement.</li> </ol>
Sanding belt will not track properly.	<ol style="list-style-type: none"> <li>1. Sanding belt is not tensioned properly.</li> <li>2. Sanding belt is stretched unevenly.</li> <li>3. Belt roller is worn.</li> </ol>	<ol style="list-style-type: none"> <li>1. Tension sanding belt (<b>Page 30</b>).</li> <li>2. Replace sanding belt (<b>Page 30</b>).</li> <li>3. Replace belt roller.</li> </ol>
Sanding belt slips during use.	<ol style="list-style-type: none"> <li>1. Sanding belt is not tensioned properly.</li> <li>2. Excessive workpiece pressure.</li> <li>3. V-belt is worn or not tensioned properly.</li> </ol>	<ol style="list-style-type: none"> <li>1. Tension sanding belt (<b>Page 30</b>).</li> <li>2. Reduce workpiece pressure against sanding belt.</li> <li>3. Inspect/tension V-belt (<b>Page 36</b>).</li> </ol>
Sanding disc slips during use.	<ol style="list-style-type: none"> <li>1. V-belt is worn or not tensioned properly.</li> <li>2. Disc shaft key is missing or broken.</li> </ol>	<ol style="list-style-type: none"> <li>1. Inspect/tension V-belt (<b>Page 36</b>).</li> <li>2. Inspect/replace disc shaft key.</li> </ol>
Excessive sanding belt or disc replacement.	<ol style="list-style-type: none"> <li>1. Not using full width of sanding surface.</li> <li>2. Excessive workpiece pressure.</li> </ol>	<ol style="list-style-type: none"> <li>1. Move workpiece back and forth across sanding surface (<b>Sanding Tips on Page 24</b>).</li> <li>2. Reduce workpiece pressure.</li> </ol>
Deep sanding grooves or scars in workpiece.	<ol style="list-style-type: none"> <li>1. Sandpaper too coarse for desired finish.</li> <li>2. Workpiece sanded across grain.</li> <li>3. Excessive pressure.</li> <li>4. Workpiece held still against belts/disc.</li> </ol>	<ol style="list-style-type: none"> <li>1. Use a finer grit sandpaper (<b>Page 24</b>).</li> <li>2. Sand workpiece with grain.</li> <li>3. Reduce workpiece pressure against sanding surface.</li> <li>4. Move workpiece back and forth across sanding surface.</li> </ol>
Burn marks on workpiece.	<ol style="list-style-type: none"> <li>1. Using too fine of sanding grit.</li> <li>2. Excessive pressure on workpiece.</li> <li>3. Workpiece held still for too long.</li> </ol>	<ol style="list-style-type: none"> <li>1. Use coarser grit sandpaper (<b>Page 24</b>).</li> <li>2. Reduce pressure on workpiece while sanding.</li> <li>3. Move workpiece back and forth across sanding surface.</li> </ol>

# Electrical Safety Instructions

These pages are accurate at the time of printing. In the constant effort to improve, however, we may make changes to the electrical systems of future machines. Study this section carefully. If you see differences between your machine and what is shown in this section, call Technical Support at (360) 734-1540 for assistance BEFORE making any changes to the wiring on your machine.

**Shock Hazard:** It is extremely dangerous to perform electrical or wiring tasks while the machine is connected to the power source. Touching electrified parts will result in personal injury including but not limited to severe burns, electrocution, or death. For your own safety, disconnect machine from the power source before servicing electrical components or performing any wiring tasks!

**Wire Connections:** All connections must be tight to prevent wires from loosening during machine operation. Double-check all wires disconnected or connected during any wiring task to ensure tight connections.

**Modifications:** Using aftermarket parts or modifying the wiring beyond what is shown in the diagram may lead to unpredictable results, including serious injury or fire.

**Motor Wiring:** The motor wiring shown in these diagrams is current at the time of printing, but it may not match your machine. Always use the wiring diagram inside the motor junction box.

**Circuit Requirements:** Connecting the machine to an improperly sized circuit will greatly increase the risk of fire. To minimize this risk, only connect the machine to a power circuit that meets the minimum requirements given in this manual.

**Capacitors/Inverters:** Some capacitors and power inverters store an electrical charge for up to 10 minutes after being disconnected from the power source. To reduce the risk of being shocked, wait at least this long before working on capacitors.

**Wire/Component Damage:** Damaged wires or components increase the risk of serious personal injury, fire, or machine damage. If you notice that any wires or components are damaged while performing a wiring task, replace those wires or components before completing the task.

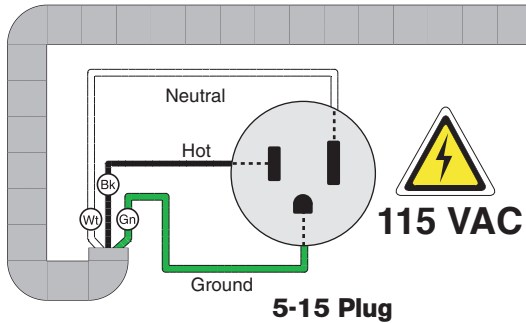
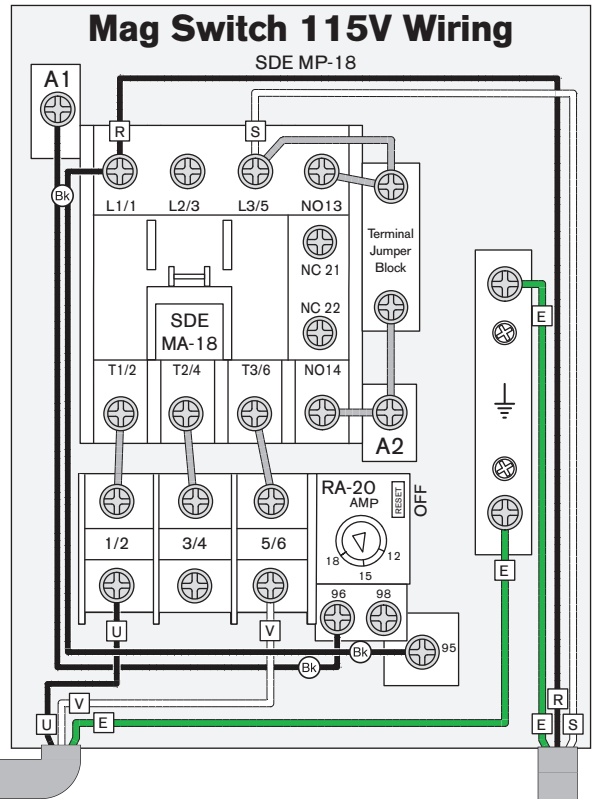
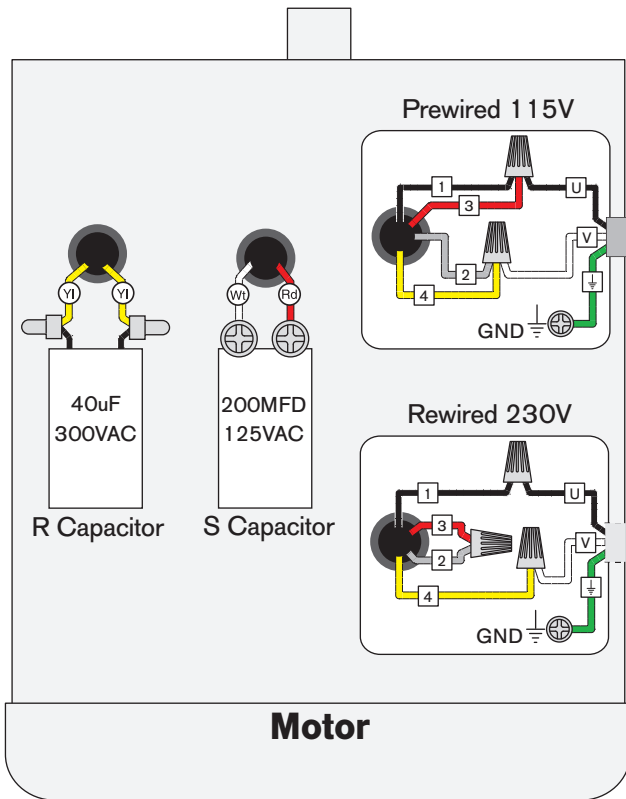
**Experiencing Difficulties:** If you are experiencing difficulties understanding the information included in this section, contact our Technical Support at (360) 734-1540.

## WIRING DIAGRAM COLOR KEY

BLACK — Bk	BLUE WHITE — Bw	RED — Rd	PINK — Pk	WHITE — Wt
BLUE — Bl	GREEN — Gn	LIGHT BLUE — Lb	PURPLE — Pu	YELLOW GREEN — Yg
BROWN — Br	GRAY — Gy	ORANGE — Or	TUR-QUIOSE — Tu	YELLOW — Yl

**NOTICE:** The photos and diagrams included in this section are best viewed in color. You can see them in color at [www.southbendtools.com](http://www.southbendtools.com).

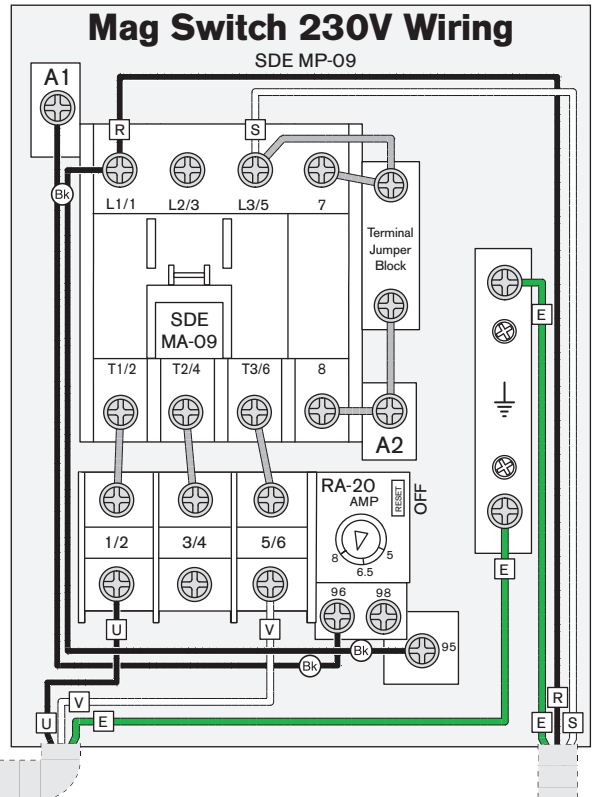
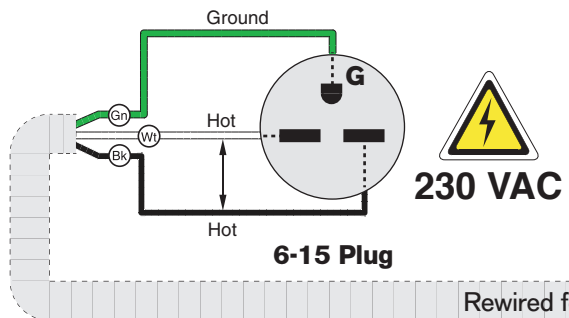
# Wiring Diagram



**WARNING!**

**SHOCK HAZARD!**

Disconnect power before working on wiring.



Rewired for 230V

# Electrical Component Pictures



Figure 69. 115V mag switch.

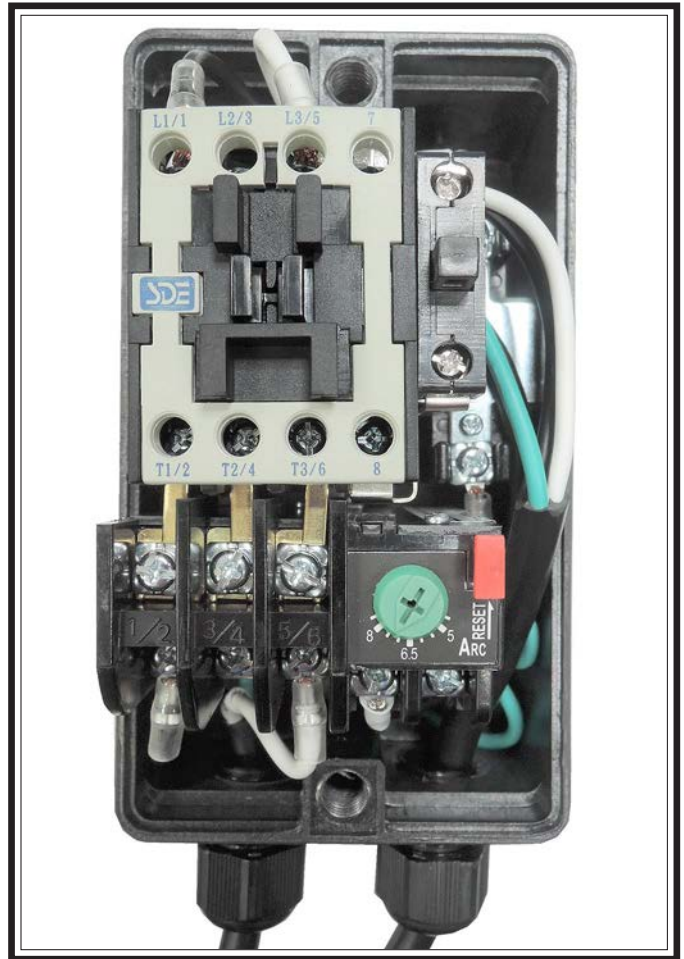


Figure 71. 230V mag switch.



Figure 70. Motor junction box (wired for 115V).



Figure 72. Motor junction box (wired for 230V).

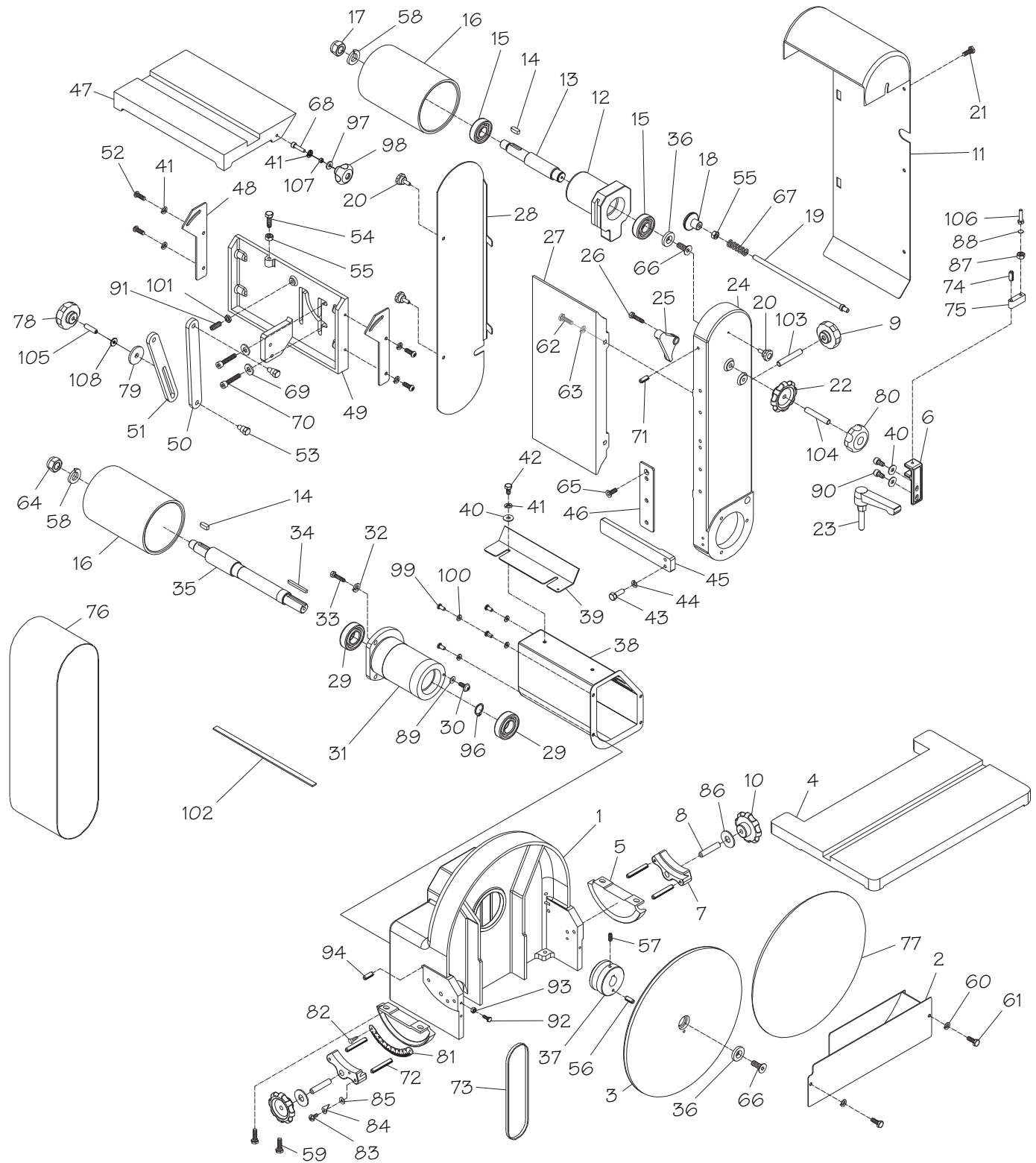


**Figure 73. Start capacitor.**



**Figure 74. Run capacitor.**

# Machine Body



REF PART #	DESCRIPTION
1	PSB1093001 DISC HOUSING
2	PSB1093002 DISC DUST CHUTE

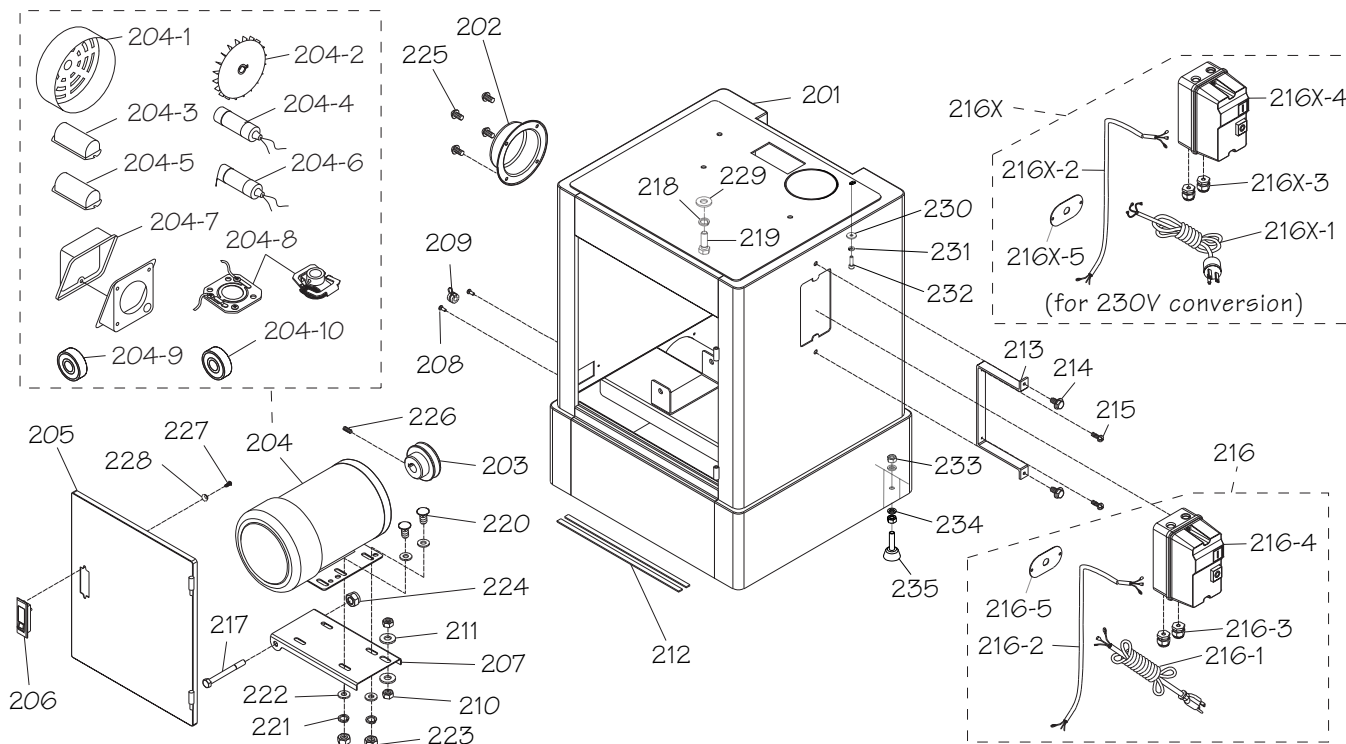
REF PART #	DESCRIPTION
3	PSB1093003 SANDING DISC PLATEN 12"
4	PSB1093004 DISC TABLE

# Machine Body Parts List (Cont.)

REF	PART #	DESCRIPTION
5	PSB1093005	TRUNNION
6	PSB1093006	TABLE BRACKET
7	PSB1093007	TRUNNION BRACKET
8	PSB1093008	SET SCREW M10-1.5 X 55
9	PSB1093009	KNOB M10-1.5, 6-LOBE, D52
10	PSB1093010	KNOB M10-1.5, 8-LOBE, D64
11	PSB1093011	SANDING BELT GUARD
12	PSB1093012	IDLER BEARING HOUSING
13	PSB1093013	IDLER SHAFT
14	PSB1093014	KEY 6 X 6 X 25 RE
15	PSB1093015	BALL BEARING 6204ZZ
16	PSB1093016	BELT ROLLER
17	PSB1093017	HEX NUT M16-2 LH
18	PSB1093018	KNOB M8-1.25, D25, ROUND
19	PSB1093019	BELT INDEX SHAFT
20	PSB1093020	KNOB BOLT M6-1 X 12, 6-LOBE, D21
21	PSB1093021	FLANGE SCREW M6-1 X 12
22	PSB1093022	KNOB M10-1.25, 8-LOBE, D63
23	PSB1093023	ADJUSTABLE HANDLE M10-1.5 X 45, 70L
24	PSB1093024	BELT FRAME
25	PSB1093025	PIVOT BLOCK
26	PSB1093026	HEX BOLT M8-1.25 X 25
27	PSB1093027	SANDING BELT PLATEN
28	PSB1093028	BELT ACCESS DOOR
29	PSB1093029	BALL BEARING 6205ZZ
30	PSB1093030	FLANGE SCREW M5-.8 X 8
31	PSB1093031	DRIVE BEARING HOUSING
32	PSB1093032	LOCK WASHER 8MM
33	PSB1093033	HEX BOLT M8-1.25 X 25
34	PSB1093034	KEY 6 X 6 X 40 RE
35	PSB1093035	DRIVE SHAFT
36	PSB1093036	FLAT WASHER 8 X 29 X 4.5MM
37	PSB1093037	DISC PULLEY
38	PSB1093038	BELT DUST CHUTE
39	PSB1093039	PINCH SHIELD
40	PSB1093040	FLAT WASHER 6MM
41	PSB1093041	LOCK WASHER 6MM
42	PSB1093042	HEX BOLT M6-1 X 12
43	PSB1093043	HEX BOLT M6-1 X 20
44	PSB1093044	LOCK WASHER 6MM
45	PSB1093045	BACK STOP
46	PSB1093046	PIVOT PLATE
47	PSB1093047	BELT TABLE
48	PSB1093048	TABLE BRACKET
49	PSB1093049	TABLE BASE
50	PSB1093050	TABLE ANGLE ADJUST BRACKET
51	PSB1093051	TABLE ANGLE BRACKET
52	PSB1093052	BUTTON HD CAP SCR M6-1 X 12
53	PSB1093053	SHOULDER BOLT M8-1.25 X 14, 9 X 18
54	PSB1093054	HEX BOLT M8-1.25 X 25
55	PSB1093055	HEX NUT M8-1.25
56	PSB1093056	ROLL PIN 6 X 20

REF	PART #	DESCRIPTION
57	PSB1093057	SET SCREW M6-1 X 8
58	PSB1093058	LOCK WASHER 16MM
59	PSB1093059	FLANGE BOLT M6-1 X 12
60	PSB1093060	LOCK WASHER 6MM
61	PSB1093061	HEX BOLT M6-1 X 8
62	PSB1093062	HEX BOLT M8-1.25 X 20
63	PSB1093063	LOCK WASHER 8MM
64	PSB1093064	HEX NUT M16-2 LH
65	PSB1093065	FLAT HD CAP SCR M6-1 X 12
66	PSB1093066	FLAT HD CAP SCR M8-1.25 X 20
67	PSB1093067	COMPRESSION SPRING 1 X 9 X 26
68	PSB1093068	CAP SCREW M6-1 X 30
69	PSB1093069	FENDER WASHER 10MM
70	PSB1093070	CAP SCREW M10-1.5 X 30
71	PSB1093071	ROLL PIN 6 X 24
72	PSB1093072	ROLL PIN 6 X 45
73	PSB1093073	V-BELT A49
74	PSB1093074	ROLL PIN 5 X 30
75	PSB1093075	STOP BLOCK
76	PSB1093076	SANDING BELT 6" X 48" 60-GRIT
77	PSB1093077	SANDING DISC 12" 60-GRIT PSA
78	PSB1093078	KNOB M8-1.25, 6-LOBE, D21
79	PSB1093079	FENDER WASHER 8 X 30 X 3MM
80	PSB1093080	KNOB M10-1.25, 6-LOBE, D52
81	PSB1093081	TABLE TILT SCALE
82	PSB1093082	RIVET 2 X 5MM NAMEPLATE
83	PSB1093083	PHLP HD SCR M6-1 X 8
84	PSB1093084	POINTER
85	PSB1093085	FLAT WASHER 6MM
86	PSB1093086	FLAT WASHER 10MM
87	PSB1093087	HEX NUT M6-1
88	PSB1093088	GASKET 1 X 10MM
89	PSB1093089	FENDER WASHER 5 X 19 X 1.5
90	PSB1093090	CAP SCREW M6-1 X 20
91	PSB1093091	SET SCREW M8-1.25 X 20
92	PSB1093092	HEX BOLT M6-1 X 25
93	PSB1093093	HEX NUT M6-1
94	PSB1093094	DOWEL PIN 6 X 20
96	PSB1093096	EXT RETAINING RING 25MM
97	PSB1093097	FENDER WASHER 6MM
98	PSB1093098	KNOB M6-1, 4-LOBE, D40
99	PSB1093099	BUTTON HD CAP SCR M6-1 X 12
100	PSB1093100	LOCK WASHER 6MM
101	PSB1093101	HEX NUT M8-1.25 THIN
102	PSB1093102	FOAM SEAL 2 X 7 X 10MM
103	PSB1093103	SET SCREW M10-1.5 X 60
104	PSB1093104	SET SCREW M10-1.25 X 60
105	PSB1093105	SET SCREW M8-1.25 X 35
106	PSB1093106	HEX BOLT M6-1 X 25
107	PSB1093107	BUSHING
108	PSB1093108	FLAT WASHER 8MM THIN

# Stand

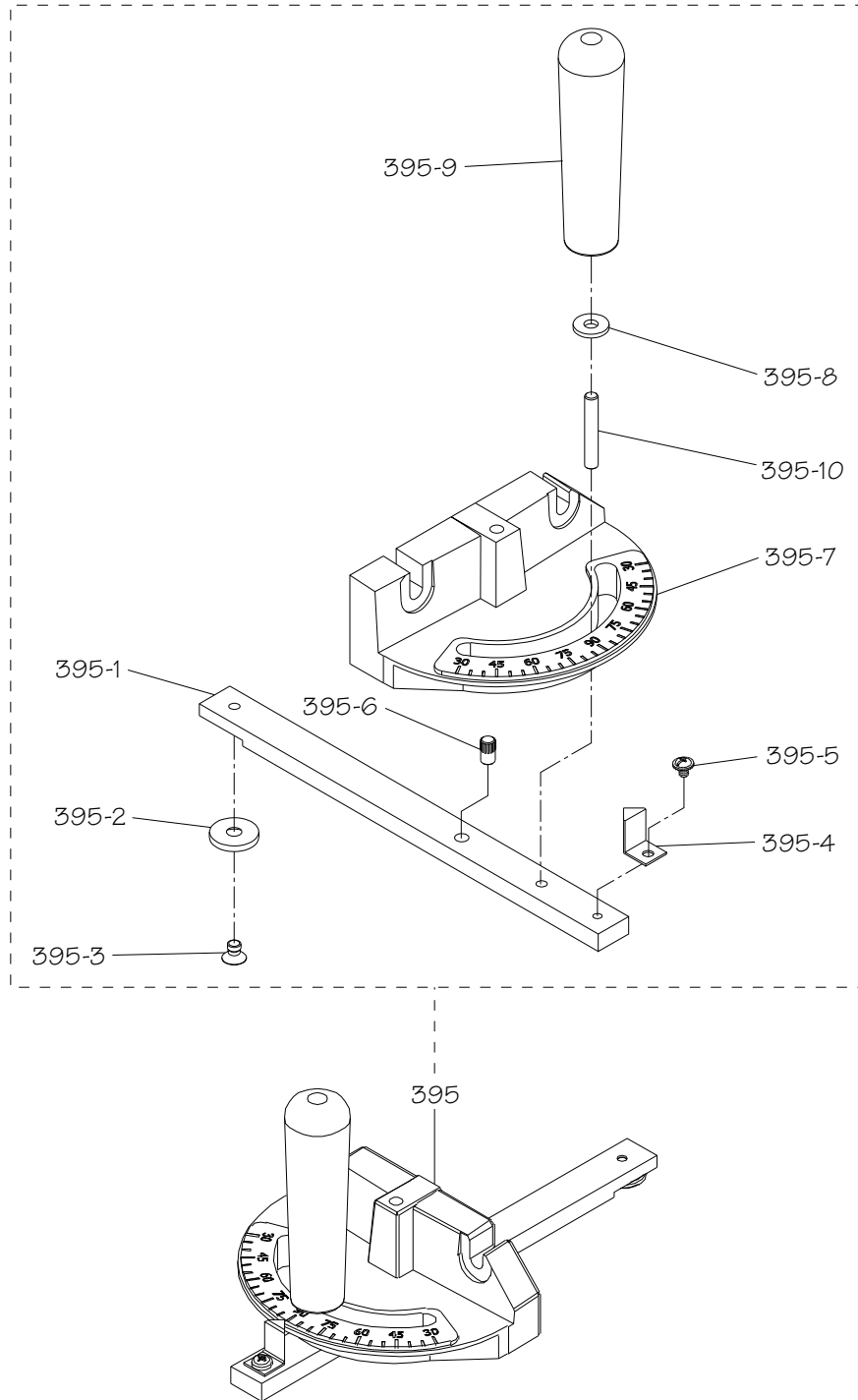


REF	PART #	DESCRIPTION
201	PSB1093201	STAND
202	PSB1093202	DUST PORT 4"
203	PSB1093203	MOTOR PULLEY
204	PSB1093204	MOTOR 1.5HP 115V/230V1-PH
204-1	PSB1093204-1	MOTOR FAN COVER
204-2	PSB1093204-2	MOTOR FAN
204-3	PSB1093204-3	S CAPACITOR COVER
204-4	PSB1093204-4	S CAPACITOR 200M 125V1-3/8 X 2-5/8
204-5	PSB1093204-5	R CAPACITOR COVER
204-6	PSB1093204-6	R CAPACITOR 40M 300V1-1/2 X 2-3/8
204-7	PSB1093204-7	MOTOR JUNCTION BOX
204-8	PSB1093204-8	CONTACT PLATE/CENTRIFUGAL SWITCH
204-9	PSB1093204-9	BALL BEARING 6203ZZ (FRONT)
204-10	PSB1093204-10	BALL BEARING 6202ZZ (REAR)
205	PSB1093205	DOOR
206	PSB1093206	DOOR LATCH ASSEMBLY
207	PSB1093207	MOTOR MOUNTING PLATE
208	PSB1093208	PHLP HD SCR M5-.8 X 12
209	PSB1093209	STRAIN RELIEF TYPE-1 5/16"
210	PSB1093210	HEX NUT M10-1.5
211	PSB1093211	FLAT WASHER 10MM
212	PSB1093212	FOAM SEAL 3 X 10 X 380MM
213	PSB1093213	SWITCH MOUNTING BRACKET
214	PSB1093214	FLANGE BOLT M8-1.25 X 20
215	PSB1093215	PHLP HD SCR M4-.7X 10
216	PSB1093216	MAGNETIC SWITCH ASSEMBLY 115V
216-1	PSB1093216-1	POWER CORD 14G 3W 78" 5-15P
216-2	PSB1093216-2	MOTOR CORD 14G 3W 22"

REF	PART #	DESCRIPTION
216-3	PSB1093216-3	STRAIN RELIEF TYPE-3 PG13.5
216-4	PSB1093216-4	MAGNETIC SWITCH SDE MP-18
216-5	PSB1093216-5	CORD PLATE
216X	PSB1093216X	MAGNETIC SWITCH ASSEMBLY 230V
216X-1	PSB1093216X-1	POWER CORD 14G 3W 78" 6-15P
216X-2	PSB1093216X-2	MOTOR CORD 14G 3W 22"
216X-3	PSB1093216X-3	STRAIN RELIEF TYPE-3 PG13.5
216X-4	PSB1093216X-4	MAGNETIC SWITCH SDE MP-09
216X-5	PSB1093216X-5	CORD PLATE
217	PSB1093217	HEX BOLT M10-1.5 X 160
218	PSB1093218	LOCK WASHER 8MM
219	PSB1093219	HEX BOLT M8-1.25 X 20
220	PSB1093220	HEX BOLT M8-1.25 X 25
221	PSB1093221	LOCK WASHER 8MM
222	PSB1093222	FLAT WASHER 8MM
223	PSB1093223	HEX NUT M8-1.25
224	PSB1093224	LOCK NUT M10-1.5
225	PSB1093225	FLANGE SCREW M6-1 X 12
226	PSB1093226	SET SCREW M6-1 X 12
227	PSB1093227	PHLP HD SCREW M4-.7X 4
228	PSB1093228	FLAT WASHER 4MM
229	PSB1093229	FENDER WASHER 8MM
230	PSB1093230	FLAT WASHER 6MM
231	PSB1093231	LOCK WASHER 6MM
232	PSB1093232	CAP SCREW M6-1 X 20
233	PSB1093233	HEX NUT M12-1.75
234	PSB1093234	FLAT WASHER 12MM
235	PSB1093235	RUBBER FOOT M12-1.75 X 68.5, 48.5



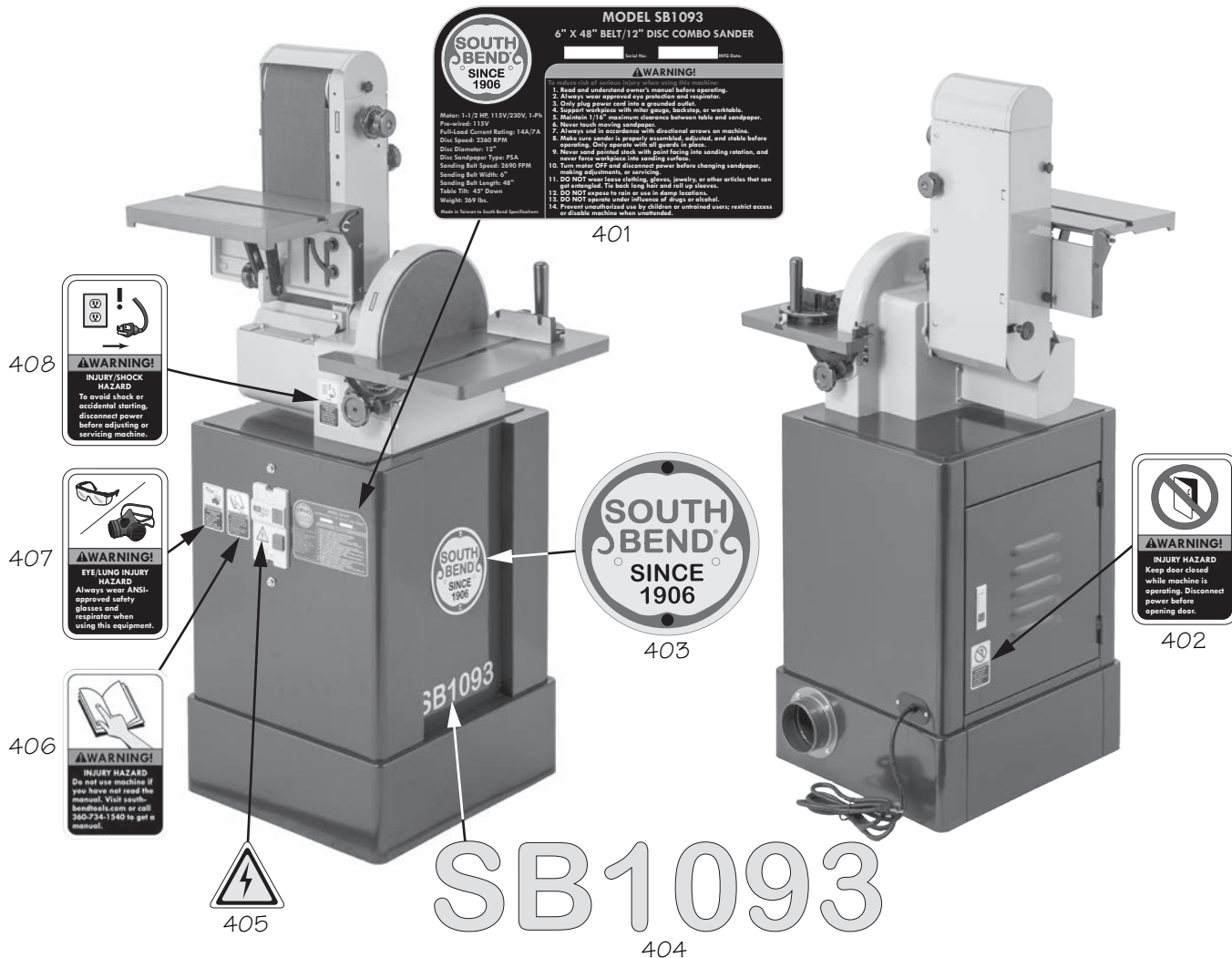
# Miter Gauge



REF	PART #	DESCRIPTION
395	PSB1093395	MITER GAUGE ASSEMBLY
395-1	PSB1093395-1	GUIDE BAR
395-2	PSB1093395-2	GUIDE WASHER 6 X 22 X 2.5MM
395-3	PSB1093395-3	FLAT HD SCR M6-1 X 6
395-4	PSB1093395-4	MITER ANGLE POINTER
395-5	PSB1093395-5	FLANGE SCREW M5-.8 X 8

REF	PART #	DESCRIPTION
395-6	PSB1093395-6	DOWEL PIN 6.5 X 10
395-7	PSB1093395-7	MITER GAUGE BODY
395-8	PSB1093395-8	FLAT WASHER 1/4 NYLON
395-9	PSB1093395-9	HOLLOW HANDLE 1-1/8 X 4-5/16, 1/4-20
395-10	PSB1093395-10	SET SCREW 1/4-20 X 1-1/2

# Machine Labels



# SB1093

REF	PART #	DESCRIPTION
401	PSB1093401	MACHINE ID LABEL
402	PSB1093402	DOOR CLOSED LABEL
403	PSB1093403	SOUTH BEND NAMEPLATE 152MM
404	PSB1093404	MODEL NUMBER LABEL

REF	PART #	DESCRIPTION
405	PSB1093405	ELECTRICITY LABEL
406	PSB1093406	READ MANUAL LABEL
407	PSB1093407	EYE/LUNG INJURY LABEL
408	PSB1093408	DISCONNECT POWER LABEL

**⚠ WARNING**

The safety labels provided with your machine are used to make the operator aware of the machine hazards and ways to prevent injury. The owner of this machine **MUST** maintain the original location and readability of these safety labels. If any label is removed or becomes unreadable, **REPLACE** that label before using the machine again. Contact South Bend Tools at (360) 734-1540 or [www.southbendtools.com](http://www.southbendtools.com) to order new labels.

# Warranty

This quality product is warranted by South Bend Tools to the original buyer for **2 years** from the date of purchase. This warranty does not apply to consumable parts, or defects due to any kind of misuse, abuse, negligence, accidents, repairs, alterations or lack of maintenance. We do not reimburse for third party repairs. In no event shall we be liable for death, injuries to persons or property, or for incidental, contingent, special or consequential damages arising from the use of our products.

We do not warrant or represent that this machine complies with the provisions of any law, act, code, regulation, or standard of any domestic or foreign government, industry, or authority. In no event shall South Bend's liability under this warranty exceed the original purchase price paid for this machine. Any legal actions brought against South Bend Tools shall be tried in the State of Washington, County of Whatcom.

This is the sole written warranty for this machine. Any and all warranties that may be implied by law, including any merchantability or fitness, for any purpose, are hereby limited to the duration of this warranty.

Thank you for your business and continued support.

To take advantage of this warranty, register at <https://www.grizzly.com/forms/warranty>, or you can scan the QR code below to be automatically directed to our warranty registration page. Enter all applicable information for the product.





[southbendtools.com](http://southbendtools.com)

