

CYCLONE DUST COLLECTORS

MODELS SB1092 & SB1094

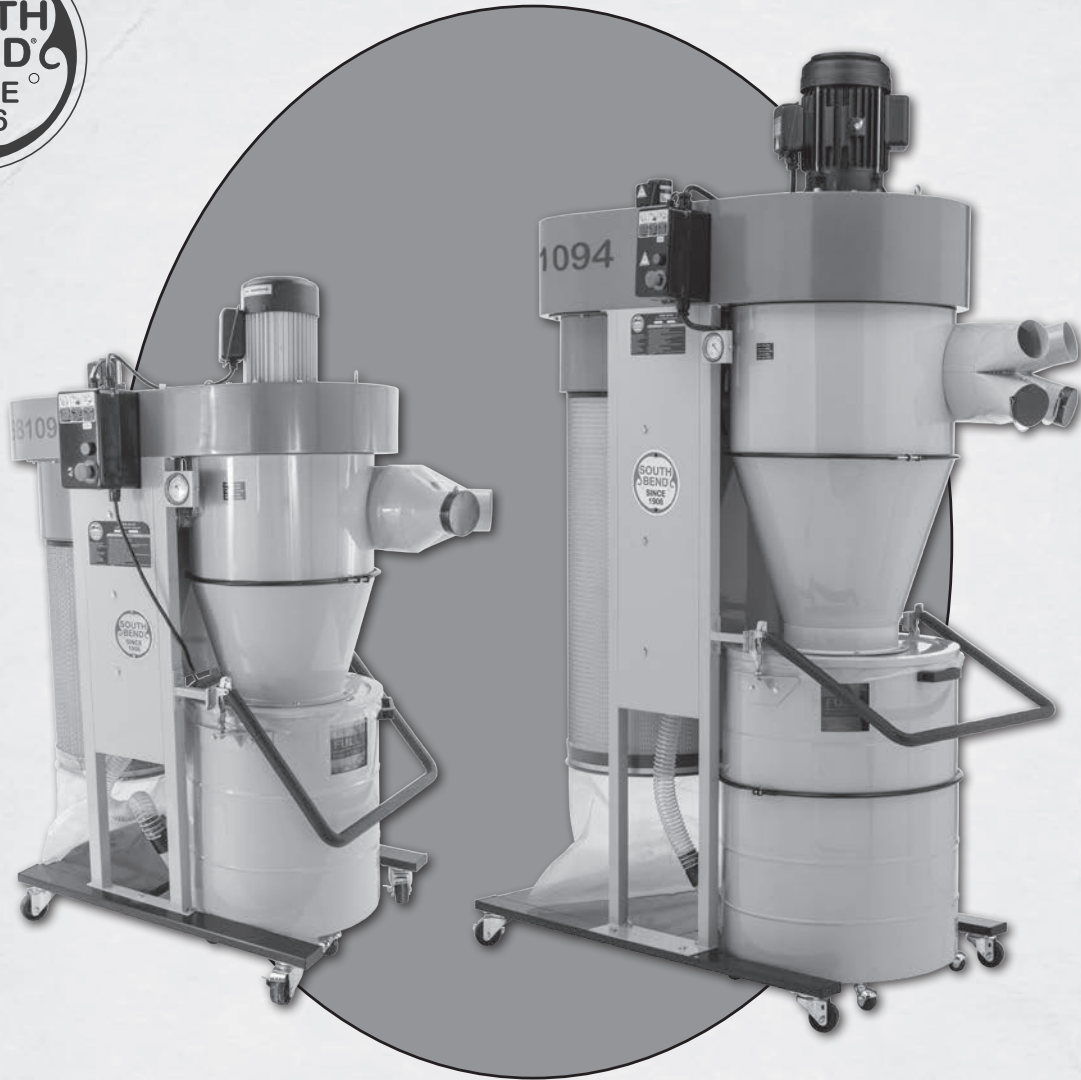

****Keep for Future Reference****

OWNER'S MANUAL

South Bend Tools®

A Tradition of Excellence

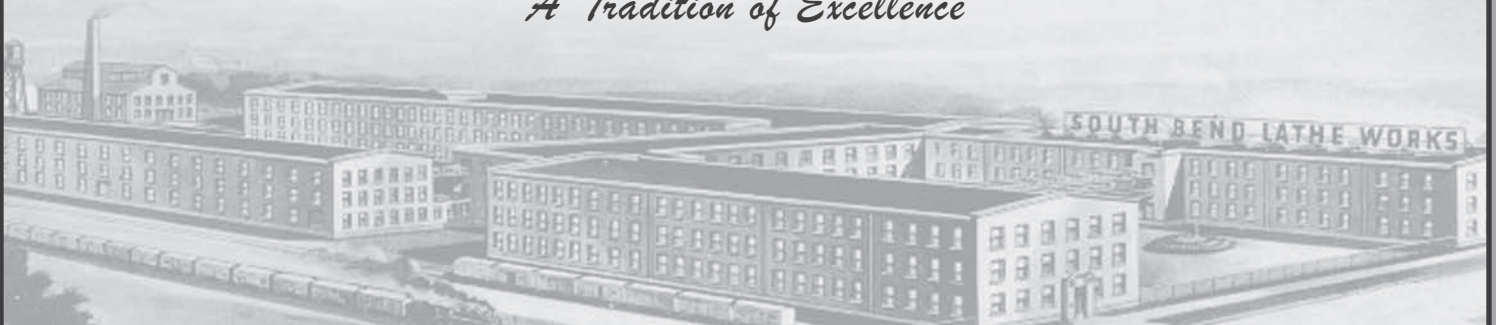

Scope of Manual

This manual helps the reader understand the machine, how to prepare it for operation, how to control it during operation, and how to keep it in good working condition. We assume the reader has a basic understanding of how to operate this type of machine, but that the reader is not familiar with the controls and adjustments of this specific model. As with all machinery of this nature, learning the nuances of operation is a process that happens through training and experience. If you are not an experienced operator of this type of machinery, read through this entire manual, then learn more from an experienced operator, schooling, or research before attempting operations. Following this advice will help you avoid serious personal injury and get the best results from your work.

Manual Feedback

We've made every effort to be accurate when documenting this machine. However, errors sometimes happen or the machine design changes after the documentation process—so the manual may not exactly match your machine. If a difference between the manual and machine leaves you in doubt, contact our customer service for clarification.

We highly value customer feedback on our manuals. If you have a moment, please share your experience using this manual. What did you like about it? Is there anything you would change to make it better? Did it meet your expectations for clarity, professionalism, and ease-of-use?

South Bend Tools
c/o Technical Documentation Manager
P.O. Box 2027
Bellingham, WA 98227
Email: manuals@southbendtools.com

Updates

For your convenience, any updates to this manual will be available to download free of charge through our website at:

www.southbendtools.com

Customer Service

We stand behind our machines. If you have any service questions, parts requests or general questions about your purchase, feel free to contact us.

South Bend Tools
P.O. Box 2027
Bellingham, WA 98227
Phone: (360) 734-1540
Fax: (360) 676-1075 (International)
Fax: (360) 734-1639 (USA Only)
Email: sales@southbendtools.com

Table of Contents

INTRODUCTION	2	OPERATION	33
Identification.....	2	Operation Overview.....	33
Description of Controls & Components	3	General Operation	33
Product Specifications	4	ACCESSORIES	34
SAFETY	7	MAINTENANCE	36
Understanding Risks of Machinery	7	Maintenance Schedule.....	36
Basic Machine Safety	7	Cleaning Canister Filter.....	36
Additional Dust Collector Safety	9	Removing/Replacing Drum Collection Bag	37
PREPARATION	10	Removing/Replacing Filter Collection Bag.....	37
Preparation Overview.....	10	SERVICE	38
Required for Setup.....	10	Removing/Replacing Canister Filter	38
Power Supply Requirements	11	Pairing Remote Control to Receiver	39
Unpacking	13	TROUBLESHOOTING	40
SB1092 Inventory	13	ELECTRICAL	42
SB1094 Inventory	14	Electrical Safety Instructions	42
Hardware Recognition Chart	15	SB1092 Wiring Diagram	43
Location	16	SB1092 Electrical Component Pictures.....	44
Assembly	17	SB1094 Wiring Diagram	45
Power Connection (SB1092).....	22	SB1094 Electrical Component Pictures.....	46
Power Connection (SB1094).....	22	PARTS	48
Test Run	23	SB1092 Parts	48
SYSTEM DESIGN	24	SB1094 Parts	50
General	24	Machine Labels	52
Duct Material.....	24	WARRANTY	53
System Design.....	26		
System Grounding	32		

Identification

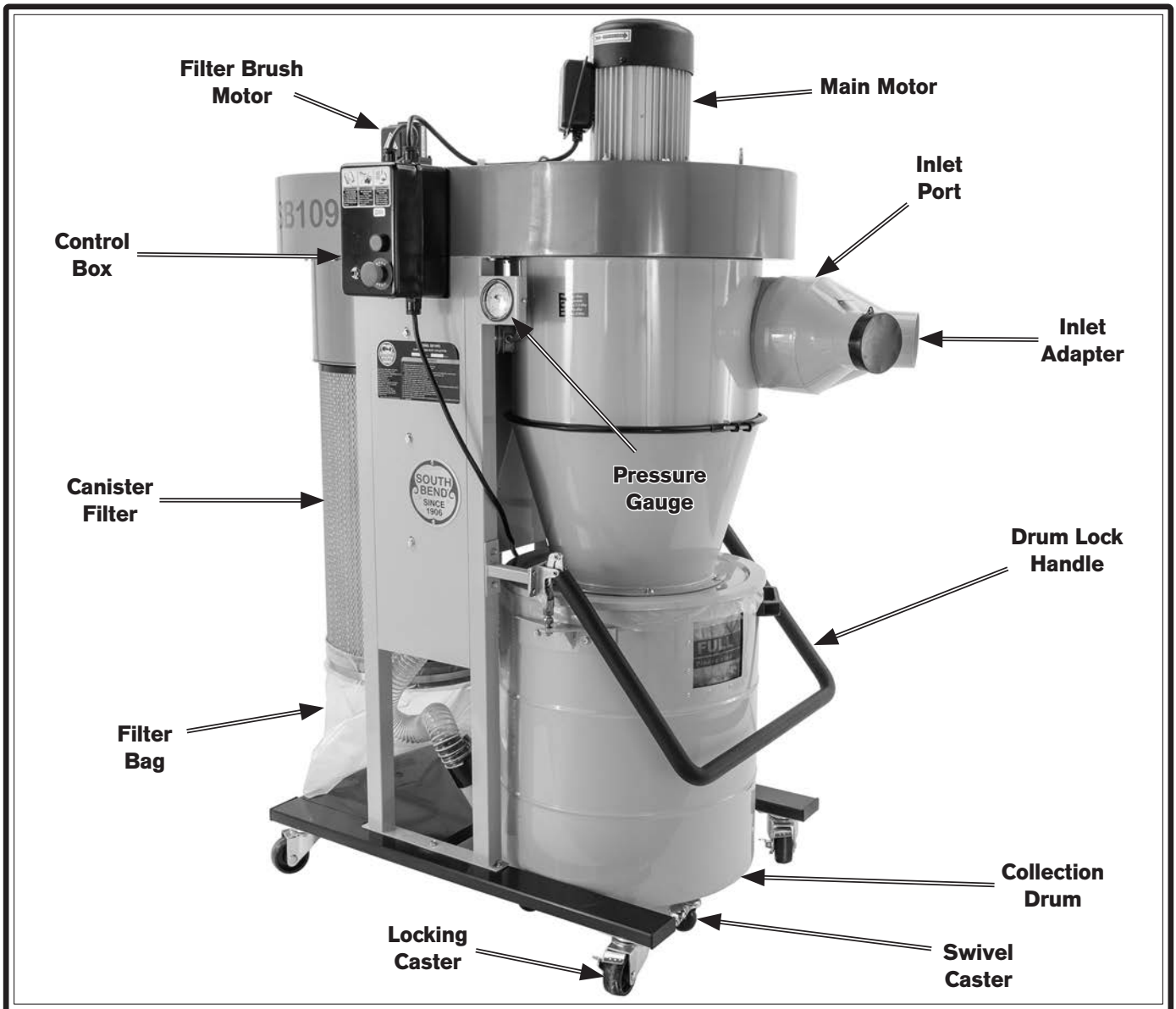

!WARNING

Serious personal injury could occur if you connect the machine to power before completing the setup process. **DO NOT** connect power until instructed to do so later in this manual.

!WARNING

Untrained users have an increased risk of seriously injuring themselves with this machine. Do not operate this machine until you have understood this entire manual and received proper training.

Description of Controls & Components

Refer to **Figures 1–2** and the following descriptions to become familiar with the basic controls and components used to operate this machine.

- A. Filter Brush Motor:** Turns **ON** automatically when main motor is turned **OFF**. Knocks dust cake off filter pleats, cleaning filter and maintaining air flow.
- B. Control Box:** Controls motor operation with a thermally protected magnetic switch. Houses an RF receiver for remote control operation.
- C. Start Button:** Turns machine **ON**.
- D. Stop Button:** Turns machine **OFF**.
- E. Inlet Adapter:** Allows connection of multiple 4" ducts to main inlet port. SB1092 adapter has two inlets and SB1094 adapter has four inlets.
- F. Pressure Gauge:** Displays vacuum pressure, indicating when filter and collection bags need to be cleaned or replaced. Clean filter when operating pressure drops below 200mmAq. If operating pressure reaches 150mmAq and cleaning does not improve performance, replace the filter.
- G. Drum Lock Handle:** Secures dust collection drum to lid when pressed down. Releases collection drum when lifted.
- H. Filter Collection Bag:** Collects fine dust particles from filter.
- I. Collection Drum:** Collects large dust particles. Equipped with vacuum equalizer for using plastic collection bags, and an inspection window to see when drum is full.
- J. Timer Indicator:** Displays current timer setting.
- K. Timer Control Buttons:** Changes timer setting between ∞ (indefinite operation), 2, 4, 6, and 8 hours.

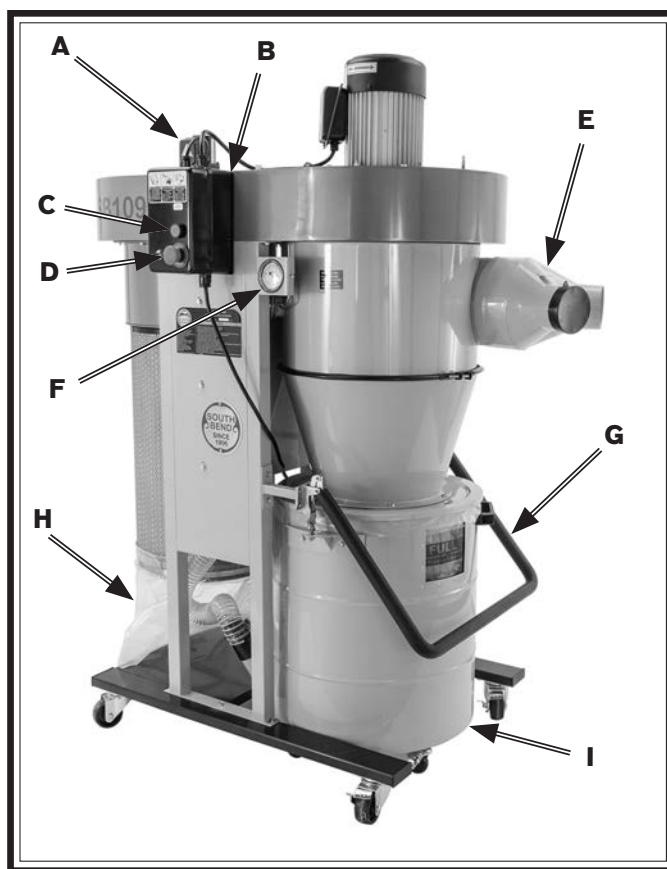

Figure 1. SB1092 & SB1094 components.

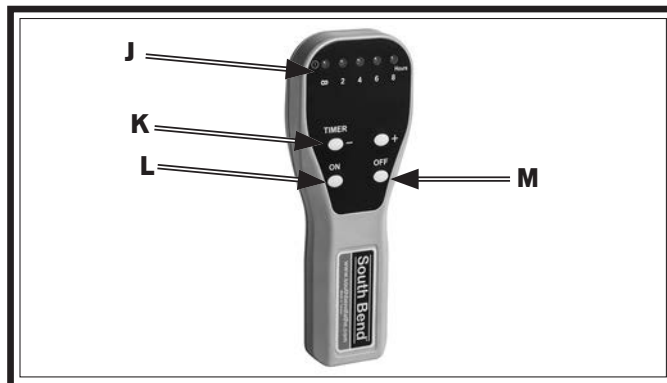

Figure 2. SB1092 & SB1094 remote control.

- L. ON Button:** Turns motor **ON**. If a timer setting is selected, motor automatically turns **OFF** after the selected amount of time.
- M. OFF Button:** Turns motor **OFF**.

Note: The remote control operates on radio frequency and has a 50-ft. range. It does not need to be aimed at the control box to operate.



Model SB1092 & SB1094 Cyclone Dust Collectors

Model Number	SB1092	SB1094
Product Dimensions		
Weight	267 lbs.	487 lbs.
Width x Depth x Height	51 x 31 x 64 in.	59 x 38 x 93-1/2 in.
Footprint (Length/Width)	26-1/2 x 36 in.	33 x 50 in.
Shipping Dimensions		
Carton #1 Type	Cardboard Box on Wooden Pallet	
Weight	330 lbs.	560 lbs.
Length x Width x Height	59 x 46 x 30 in.	78 x 32 x 51 in.
Operation		
Dust Collector Type	Two-Stage (Cyclone)	
Approved Dust Types	Wood	
Filter Type	Pleated Cartridge	
Airflow Performance	1132 CFM @ 1.1 in. SP	2399 CFM @ 2.12 in. SP
Max Static Pressure (at 0 CFM)	11.5 in.	11.4 in.
Main Inlet Size	8 in.	10 in.
Number of Adapter Inlets	2	4
Adapter Inlet Size	4 in.	
Machine Collection Capacity at One Time	2	4
Maximum Material Collection Capacity	28 Gallons	60 Gallons
Filtration Rating	1 Micron at 80% Efficiency	
Filter Surface Area	29 sq. ft.	90 sq. ft.

Model Number	SB1092	SB1094
Electrical		
Power Requirement	220V, Single-Phase, 60 Hz	
Full-Load Current Rating	9A	34A
Minimum Circuit Size	15A	50A
Connection Type	Cord & Plug	Permanent (Hardwire to Shutoff)
Power Cord Included	Yes	
Power Cord Length	130 in.	125 in.
Power Cord Gauge	14 AWG	8 AWG
Plug Included	Yes	N/A
Included/Recommended Plug Type	6-15	N/A
Switch Type	Remote Control Magnetic Switch w/Overload Protection	
Main Motor		
Type	TEFC Capacitor-Start Induction	
Horsepower	2 HP	5 HP
Phase	Single-Phase	
Amps	9A	34A
Speed	3450 RPM	
Power Transfer	Direct	
Bearings	Shielded & Permanently Lubricated	
Centrifugal Switch/Contacts Type	External	
Filter Brush Motor		
Type	TENV Induction	
Horsepower	6W	15W
Phase	Single-Phase	
Amps	0.12A	0.16A
Speed	1600 RPM	
Power Transfer	Direct	
Bearings	Shielded & Permanently Lubricated	
Centrifugal Switch/Contacts Type	External	

Model Number	SB1092	SB1094
Bag Information		
Number of Filter Bags	1	
Number of Collection Drum Bags	1	
Filter Bag Diameter	15 in.	20 in.
Filter Bag Length	19-11/16 in.	23-5/8 in.
Collection Drum Bag Diameter	19-1/2 in.	24-1/2 in.
Collection Drum Bag Length	32-11/16 in.	47-1/4 in.
Canister Information		
Number of Canister Filters	1	
Canister Filter Diameter	14-1/2 in.	19-5/8 in.
Canister Filter Length	23-5/8 in.	39-1/4 in.
Collection Drum Size	28 Gallons	60 Gallons
Impeller Information		
Impeller Type	Radial Fin	
Impeller Size	14-1/2 in.	15-5/8 in.
Impeller Blade Thickness	2.3mm	3mm
Construction		
Filter Collection Bag	Clear Plastic	
Drum Collection Bag	Clear Plastic	
Canister	Spun Bond Polyester	
Base	Steel	
Frame	Steel	
Impeller	Steel	
Paint Type/Finish	Powder Coated	
Blower Housing	Steel	
Body	Steel	
Collection Drum	Steel	
Manufacturer Specifications		
Country of Origin	Taiwan	
Warranty	2 Years	
Approximate Assembly & Setup Time	1 Hour	
Serial Number Location	ID Label	
Sound Rating	77 - 79 dB	84 - 86 dB

Understanding Risks of Machinery

Operating all machinery and machining equipment can be dangerous or relatively safe depending on how it is installed and maintained, and the operator's experience, common sense, risk awareness, working conditions, and use of personal protective equipment (safety glasses, respirators, etc.).

The owner of this machinery or equipment is ultimately responsible for its safe use. This responsibility includes proper installation in a safe environment, personnel training and usage authorization, regular inspection and maintenance, manual availability and comprehension, application of safety devices, integrity of cutting tools or accessories, and the usage of approved personal protective equipment by all operators and bystanders.

The manufacturer of this machinery or equipment will not be held liable for injury or property damage from negligence, improper training, machine modifications, or misuse. Failure to read, understand, and follow the manual and safety labels may result in serious personal injury, including amputation, broken bones, electrocution, or death.

The signals used in this manual to identify hazard levels are as follows:



Death or catastrophic harm WILL occur.



Moderate injury or fire MAY occur.



Death or catastrophic harm COULD occur.



Machine or property damage may occur.

Basic Machine Safety

Owner's Manual: All machinery and machining equipment presents serious injury hazards to untrained users. To reduce the risk of injury, anyone who uses THIS item MUST read and understand this entire manual before starting.

Personal Protective Equipment: Operating or servicing this item may expose the user to flying debris, dust, smoke, dangerous chemicals, or loud noises. These hazards can result in eye injury, blindness, long-term respiratory damage, poisoning, cancer, reproductive harm or hearing loss. Reduce your risks from these hazards by wearing approved eye protection, respirator, gloves, or hearing protection.

Trained/Supervised Operators Only: Untrained users can seriously injure themselves or bystanders. Only allow trained and properly supervised personnel to operate this item. Make sure safe operation instructions are clearly understood. If electrically powered, use padlocks and master switches, and remove start switch keys to prevent unauthorized use or accidental starting.

Guards/Covers: Accidental contact with moving parts during operation may cause severe entanglement, impact, cutting, or crushing injuries. Reduce this risk by keeping any included guards/covers/doors installed, fully functional, and positioned for maximum protection.

Entanglement: Loose clothing, gloves, neckties, jewelry or long hair may get caught in moving parts, causing entanglement, amputation, crushing, or strangulation. Reduce this risk by removing/securing these items so they cannot contact moving parts.

Mental Alertness: Operating this item with reduced mental alertness increases the risk of accidental injury. Do not let a temporary influence or distraction lead to a permanent disability! Never operate when under the influence of drugs/alcohol, when tired, or otherwise distracted.

Safe Environment: Operating electrically powered equipment in a wet environment may result in electrocution; operating near highly flammable materials may result in a fire or explosion. Only operate this item in a dry location that is free from flammable materials.

Electrical Connection: With electrically powered equipment, improper connections to the power source may result in electrocution or fire. Always adhere to all electrical requirements and applicable codes when connecting to the power source. Have all work inspected by a qualified electrician to minimize risk.

Disconnect Power: Adjusting or servicing electrically powered equipment while it is connected to the power source greatly increases the risk of injury from accidental startup. Always disconnect power **BEFORE** any service or adjustments, including changing blades or other tooling.

Secure Workpiece/Tooling: Loose workpieces, cutting tools, or rotating spindles can become dangerous projectiles if not secured or if they hit another object during operation. Reduce the risk of this hazard by verifying that all fastening devices are properly secured and items attached to spindles have enough clearance to safely rotate.

Chuck Keys or Adjusting Tools: Tools used to adjust spindles, chucks, or any moving/rotating parts will become dangerous projectiles if left in place when the machine is started. Reduce this risk by developing the habit of always removing these tools immediately after using them.

Work Area: Clutter and dark shadows increase the risks of accidental injury. Only operate this item in a clean, non-glaring, and well-lit work area.

Properly Functioning Equipment: Poorly maintained, damaged, or malfunctioning equipment has higher risks of causing serious personal injury compared to those that are properly maintained. To reduce this risk, always maintain this item to the highest standards and promptly repair/service a damaged or malfunctioning component. Always follow the maintenance instructions included in this documentation.

Unattended Operation: Electrically powered equipment that is left unattended while running cannot be controlled and is dangerous to bystanders. Always turn the power **OFF** before walking away.

Health Hazards: Certain cutting fluids and lubricants, or dust/smoke created when cutting, may contain chemicals known to the State of California to cause cancer, respiratory problems, birth defects, or other reproductive harm. Minimize exposure to these chemicals by wearing approved personal protective equipment and operating in a well ventilated area.

Difficult Operations: Attempting difficult operations with which you are unfamiliar increases the risk of injury. If you experience difficulties performing the intended operation, **STOP!** Seek an alternative method to accomplish the same task, ask a qualified expert how the operation should be performed, or contact our Technical Support for assistance.

Additional Dust Collector Safety

⚠️ WARNING

Long-term respiratory damage can occur from using dust collectors without proper use of a respirator. Fire or explosions can result in smoke inhalation, serious burns, or death—if machine is used to collect incorrect materials, is operated near potential explosion sources, or ducting is improperly grounded. Entanglement, amputation, or death can occur if hair, clothing, or fingers are pulled into the inlet. To reduce the risk of these hazards, operator and bystanders MUST completely heed the hazards and warnings below.

Intended Use. Collecting the wrong materials can result in serious inhalation hazards, fire, explosions, or machine damage. This machine is **ONLY** designed to collect wood dust and chips from woodworking machines. **DO NOT** use it to collect silica, polyurethane, toxic fumes, metal dust or shavings, lead paint, drywall, asbestos, biohazards, explosive dusts, flammable or combustible liquids or fumes, nor burning or smoking material.

Wear a Respirator. Fine dust that is too small to be caught in filter will be blown into ambient air. Always wear a NIOSH-approved respirator during operation and for a short time after to reduce your risk of permanent respiratory damage. Never collect dust from any hazardous material.

Impeller Hazards. To reduce risk of entanglement or contact with impeller, **DO NOT** place hands, hair, clothing, or tools in or near open dust collection inlet during operation, and keep small animals and children away. The powerful suction could easily pull them into impeller.

Hazardous Dust. Dust exposure created while using machinery may cause cancer, birth defects, or long-term respiratory damage. Be aware of dust hazards associated with each workpiece material, and always wear a NIOSH-approved respirator.

Emptying Dust. When emptying bag or drum, wear respirator and safety glasses. Empty dust away from ignition sources and into approved container.

Operating Location. To reduce respiratory exposure to fine dust, locate permanently installed dust collectors away from working area or in another room. **DO NOT** place dust collector where it can be exposed to rain or moisture, which creates a shock hazard and will reduce life of machine.

Power Disconnect. Turn machine **OFF**, disconnect from power supply, and allow impeller to completely stop before leaving machine unattended, or doing any maintenance or service.

Regular Cleaning. To reduce risk of starting a fire, regularly check/empty collection bags or drum to avoid buildup of fine dust, which can increase risk of fire. Regularly clean surrounding area where machine is operated—excessive dust buildup on overhead lights, heaters, electrical panels, or other heat sources will increase risk of fire.

Suspended Dust Particles. To reduce risk of death or injury caused by explosions or fires, **DO NOT** operate in areas where these risks are high, including spaces near pilot lights, open flames, or other ignition sources.

Avoiding Sparks. To reduce risk of fire, avoid collecting any metal objects or stones. These can possibly produce sparks when they strike impeller, which can smolder in wood dust for a long time before a fire is detected. If you accidentally cut into wood containing metal, immediately turn **OFF** dust collector, disconnect from power, and wait for impeller to stop. Then empty bag or drum into approved airtight metal container.

Fire Suppression. Only operate dust collector in locations that contain fire suppression system or have fire extinguisher nearby.

Static Electricity. To reduce risk of fire or explosions caused by sparks from static electricity, ground all ducting using grounding wire.

Dust Allergies. Dust from certain woods will cause an allergic reaction. Make sure you know what type of wood dust you will be exposed to in case of an allergic reaction.

Preparation Overview

The purpose of the preparation section is to help you prepare your machine for operation. The list below outlines the basic process. Specific steps for each of these points will be covered in detail later in this section.

The typical preparation process is as follows:

1. Unpack the machine and inventory the contents of the box/crate.
2. Clean the machine and its components.
3. Identify an acceptable location for the machine and move it to that location.
4. Assemble the loose components and make any necessary adjustments or inspections to ensure the machine is ready for operation.
5. Connect the machine to the power source.
6. Test run the machine to make sure it functions properly and is ready for operation.

WARNING

Like all machinery there is potential danger when operating this machine. Accidents are frequently caused by lack of familiarity or failure to pay attention. Use this machine with respect and caution to decrease the risk of operator injury. If normal safety precautions are overlooked or ignored, serious personal injury may occur.

Required for Setup

The items listed below are required to successfully set up and prepare this machine for operation.

For Lifting

- A forklift or hoist (rated for at least 500 lbs.).
- Lifting straps or chains and hooks (rated for at least 500 lbs.).

For Power Connection

- A power source that meets the minimum circuit requirements for this machine. (Refer to the **Power Supply Requirements** section for details.)
- A qualified electrician to ensure a safe and code-compliant connection to the power source.

For Assembly

- An Assistant
- Safety Glasses (for each person)
- Phillips Screwdriver #2

CAUTION

No list of safety guidelines can be complete. Every shop environment is different. Always consider safety first, as it applies to your individual working conditions. Use this and other machinery with caution and respect. Failure to do so may result in serious personal injury or property damage.

Power Supply Requirements

Availability

Before installing the machine, consider the availability and proximity of the required power supply circuit. If an existing circuit does not meet the requirements for this machine, a new circuit must be installed.

To minimize the risk of electrocution, fire, or equipment damage, installation work and electrical wiring must be done by an electrician or qualified service personnel in accordance with applicable electrical codes and safety standards.

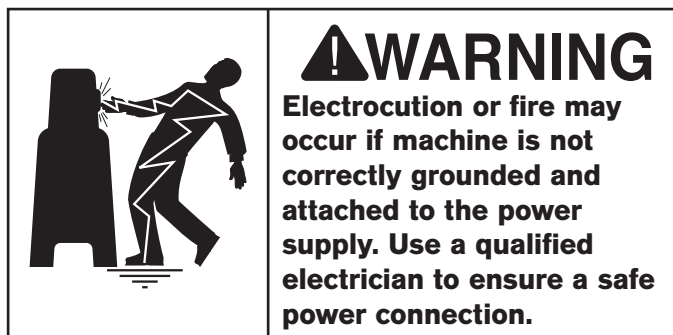

Full-Load Current Rating

The full-load current rating is the amperage a machine draws at 100% of the rated output power. On machines with multiple motors, this is the amperage drawn by the largest motor or sum of all motors and electrical devices that might operate at one time during normal operations.

SB1092 at 220V 9 Amps
SB1094 at 220V 34 Amps

The full-load current is not the maximum amount of amps that the machine will draw. If the machine is overloaded, it will draw additional amps beyond the full-load rating.

If the machine is overloaded for a sufficient length of time, damage, overheating, or fire may result—especially if connected to an undersized circuit. To reduce the risk of these hazards, avoid overloading the machine during operation and make sure it is connected to a power supply circuit that meets the requirements in the following section.

Circuit Information

A power supply circuit includes all electrical equipment between the main breaker box or fuse panel in your building and the incoming power connections inside the machine. This circuit must be safely sized to handle the full-load current that may be drawn from the machine for an extended period of time. (If this machine is connected to a circuit protected by fuses, use a time delay fuse marked D.)

Note: The circuit requirements in this manual are for a dedicated circuit—where only one machine will be running at a time. If this machine will be connected to a shared circuit where multiple machines will be running at the same time, consult a qualified electrician to ensure the circuit is properly sized.



Grounding Requirements

This machine must be grounded! In the event of certain types of malfunctions or breakdowns, grounding provides a path of least resistance for electric current in order to reduce the risk of electric shock.

Improper connection of the equipment-grounding wire can result in a risk of electric shock. The wire with green insulation (with or without yellow stripes) is the equipment-grounding wire. If repair or replacement of the power cord or plug is necessary, do not connect the equipment-grounding wire to a live (current carrying) terminal.

Check with an electrician or qualified service personnel if you do not understand these grounding requirements, or if you are in doubt about whether the tool is properly grounded.

If you ever notice that a cord or plug is damaged or worn, disconnect it from power, and immediately replace it with a new one.

SB1092 Circuit Information

This machine is prewired to operate on a power supply circuit that has a verified ground and meets the following requirements:

- Nominal Voltage 220V
- Cycle 60 Hz
- Phase Single-Phase
- Circuit Rating..... 15 Amps
- Plug/Receptacle (included) NEMA 6-15

This machine is equipped with a power cord that has an equipment-grounding wire and a grounding plug (similar to the figure below). The plug must only be inserted into a matching receptacle (outlet) that is properly installed and grounded in accordance with all local codes and ordinances.

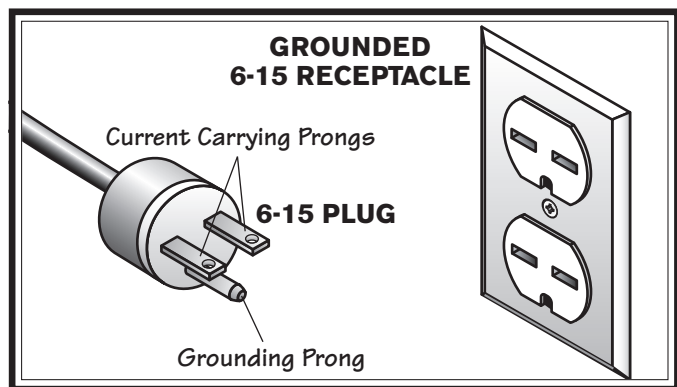

Figure 3. NEMA 6-15 plug and receptacle.

Extension Cords (SB1092 Only)

We do not recommend using an extension cord with this machine. If you must use one, only use it if absolutely necessary and only on a temporary basis.

Extension cords cause voltage drop, which may damage electrical components and shorten motor life. Voltage drop increases as the extension cord size gets longer and the gauge size gets smaller (higher gauge numbers indicate smaller sizes).

Any extension cord used with this machine must contain a ground wire, match the required plug and receptacle listed in the **Circuit Requirements** for the applicable voltage, and meet the following requirements:

- Minimum Gauge Size.....14 AWG
- Maximum Length (Shorter is Better)50 ft.

CAUTION

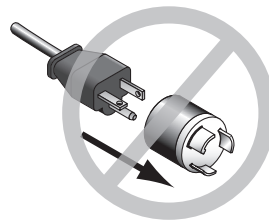

No adapter should be used with plug. If plug does not fit available receptacle, or if machine must be reconnected for use on a different type of circuit, reconnection must be performed by an electrician or qualified service personnel, and it must comply with all local codes and ordinances.

SB1094 Circuit Information

This machine is prewired to operate on a power supply circuit that has a verified ground and meets the following requirements:

- Nominal Voltage 220V
- Cycle 60 Hz
- Phase Single-Phase
- Circuit Rating..... 50 Amps
- Connection Hardwire with Locking Switch

A permanently connected (hardwired) power supply is typically installed with wires running through mounted and secured conduit. A disconnecting means, such as a locking switch (see **Figure 4**), must be provided to allow the machine to be disconnected (isolated) from the power supply when required. This installation must be performed by an electrician in accordance with all applicable electrical codes and ordinances.

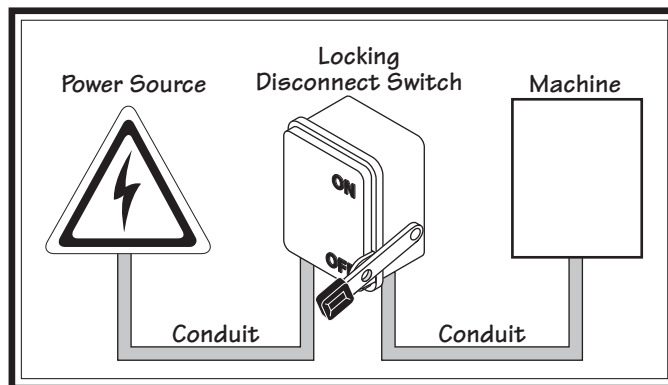

Figure 4. Typical hardwire setup with locking disconnect switch.

Unpacking

This item was carefully packaged to prevent damage during transport. If you discover any damage, please immediately call Customer Service at (360) 734-1540 for advice. You may need to file a freight claim, so take pictures and save all the containers and packing materials for possible inspection by the carrier or its agent.

SB1092 Inventory

Main Inventory (Figure 5)	Qty
A. Canister Filter.....	1
B. Housing Assembly.....	1
C. Collection Drum	1
D. Left Drum Bracket.....	1
E. Right Drum Bracket	1
F. Cone	1
G. Collection Drum Handle	1
H. Base	1
I. Drum Lid	1
J. Support Panel.....	1
K. Side Panel (Left)	1
L. Side Panel (Right).....	1
M. Inlet Adapter	1
N. Hose 2"	1
O. Quick Connector.....	1
P. Hose Clamps 2"	2
Q. Bag Clamp	1
R. Cone Clamp.....	1
S. Collection Bag, Drum (Clear Plastic).....	1
T. Drum Lock Handle Brackets.....	2
U. Drum Lock Handle.....	1
V. Collection Bag, Filter (Clear Plastic).....	1
W. Swivel Casters.....	2
X. Locking Swivel Casters	2
Y. Pressure Gauge Assembly	1
Z. Drum Casters.....	4
AA. Phillips Head Screws M5-.8 x 8.....	8
AB. Remote Control	1
AC. Hardware Bag	1
—Flange Bolts 5/16"-18 x 1/2".....	40
—Flange Bolts 5/16"-18 x 3/4".....	8
—Flange Bolts 5/16"-18 x 3/8".....	4
—Flange Bolts 1/4"-20 x 1/2".....	6
—Flat Head Screws 1/4"-20 x 1/2".....	2
—Open-Ends Wrench 10/12mm.....	1
AD. Foam Tape Roll 3/4" x 50" (Not Shown).....	1

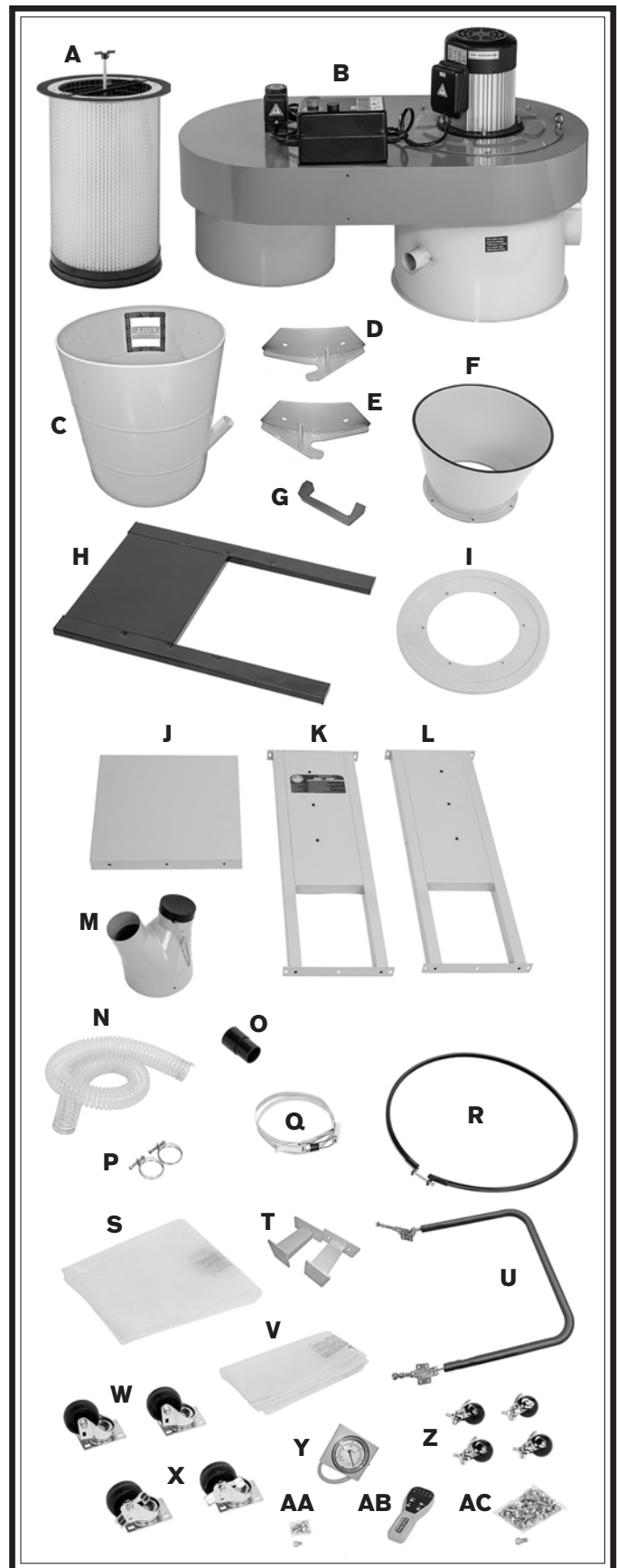

Figure 5. SB1092 main inventory.

SB1094 Inventory

Main Inventory (Figure 7)

	Qty
A. Housing Assembly.....	1
B. Right Drum Bracket	1
C. Left Drum Bracket.....	1
D. Upper Drum	1
E. Lower Drum	1
F. Cone	1
G. Base	1
H. Drum Lid	1
I. Upper Drum Handle	1
J. Support Panel.....	1
K. Side Panel (Left)	1
L. Side Panel (Right).....	1
M. Cone Clamp	1
N. Drum Clamp.....	1
O. Hoses 2"	2
P. Bag Clamp	1
Q. Hose Clamps 2"	4
R. Quick Connectors.....	2
S. Inlet Adapter	1
T. Collection Bag, Drum (Clear Plastic).....	1
U. Drum Lock Handle Brackets.....	2
V. Drum Lock Handle.....	1
W. Swivel Casters.....	2
X. Collection Bag, Filter (Clear Plastic)	1
Y. Locking Swivel Casters	2
Z. Pressure Gauge Assembly	1
AA. Drum Casters.....	4
AB. Phillips Head Screws M5-.8 x 8.....	8
AC. Remote Control	1
AD. Hardware Bag	1
—Flange Bolts 5/16"-18 x 1/2"	42
—Flange Bolts 5/16"-18 x 3/4"	8
—Flange Bolts 5/16"-18 x 3/8"	4
—Flange Bolts 1/4"-20 x 1/2"	6
—Flat Head Screws 1/4"-20 x 1/2".....	2
—Open-Ends Wrench 10/12mm.....	1
AE. Foam Tape Roll 3/4" x 50" (Not Shown).....	1

Filter Box (Figure 6)

	Qty
AF. Canister Filter.....	1

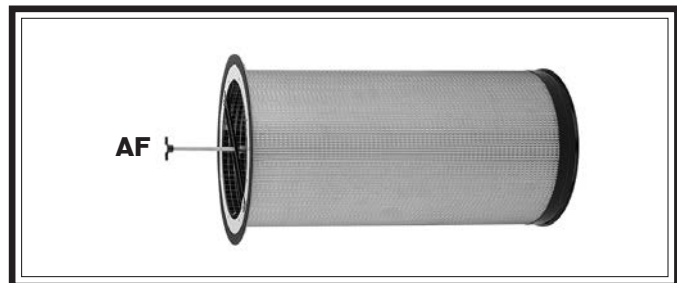

Figure 6. SB1094 canister filter.

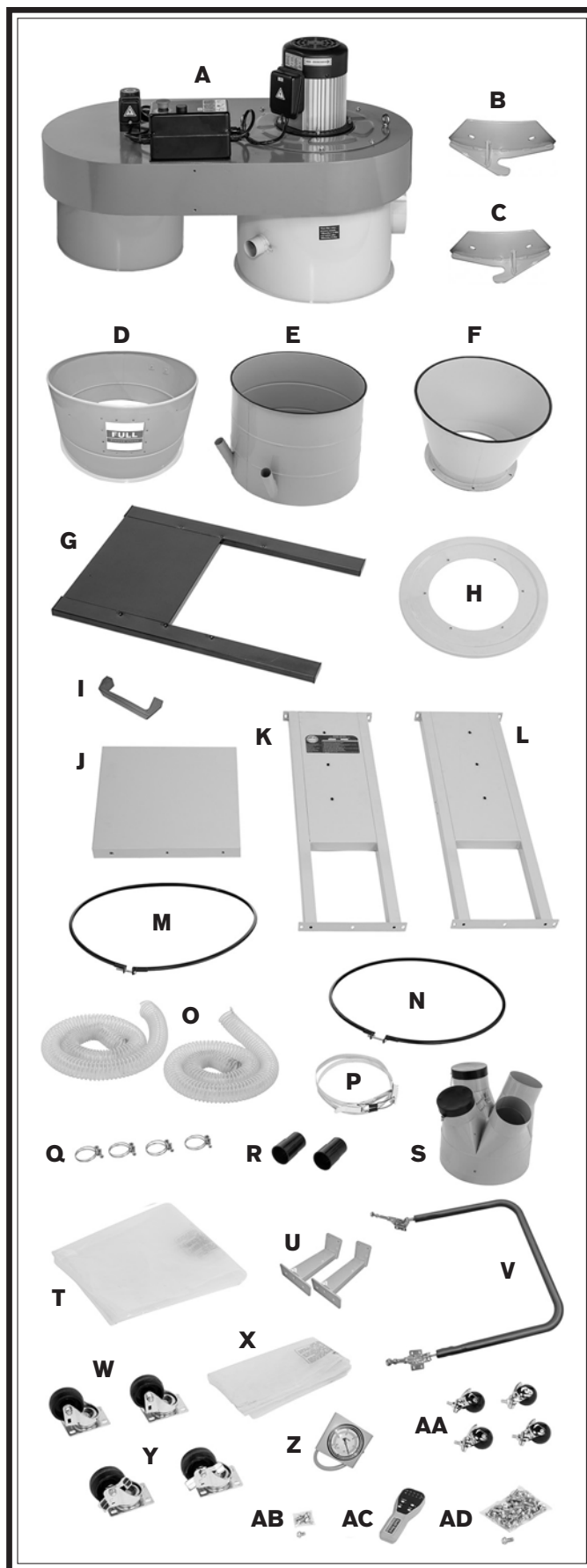

Figure 7. SB1094 main inventory.

Hardware Recognition Chart

USE THIS CHART TO MATCH UP
HARDWARE DURING THE INVENTORY
AND ASSEMBLY PROCESS.

MEASURE BOLT DIAMETER BY PLACING INSIDE CIRCLE

- #10
- 1/4"
- 5/16"
- 3/8"
- 7/16"
- 1/2"

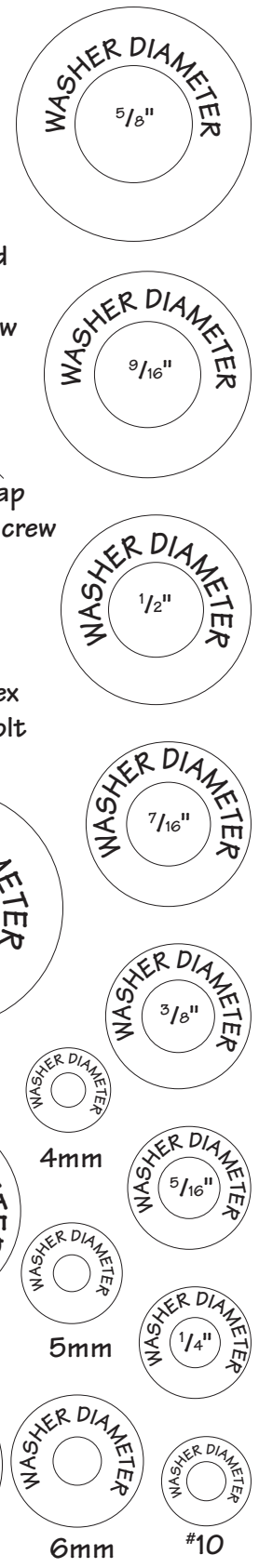
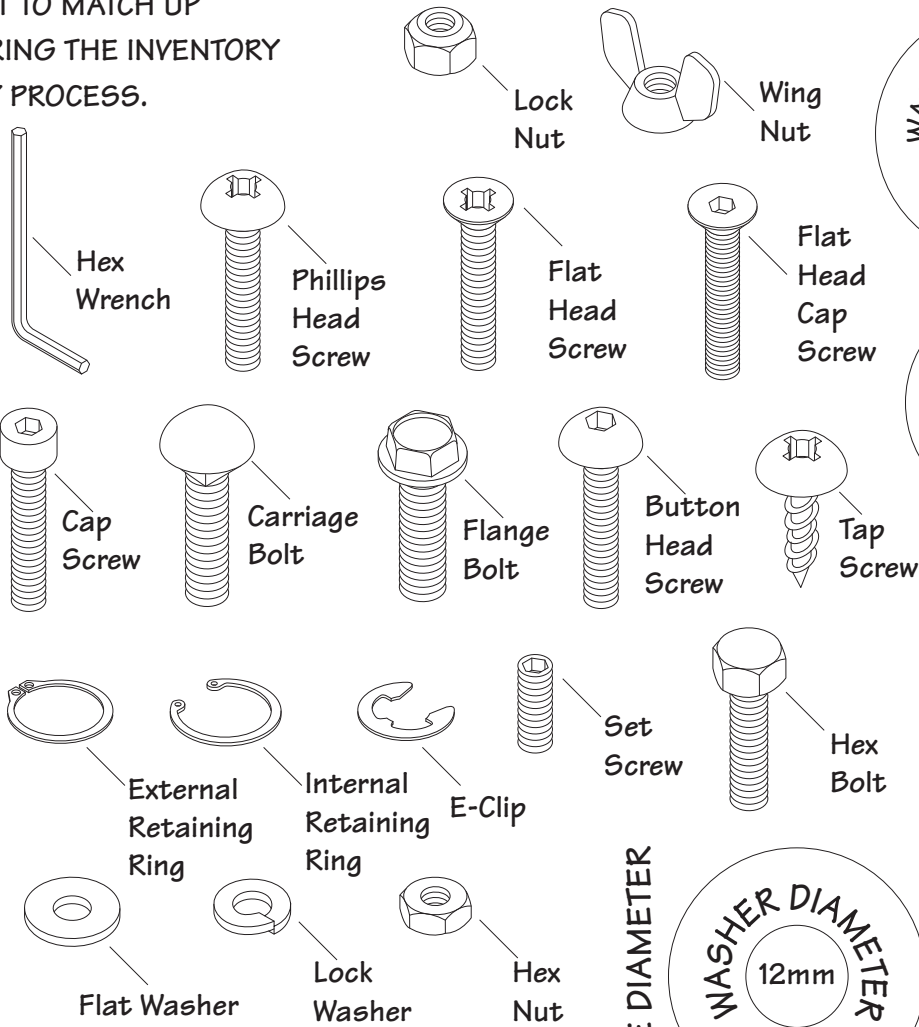

- 4mm
- 5mm
- 6mm
- 8mm
- 10mm
- 12mm
- 16mm

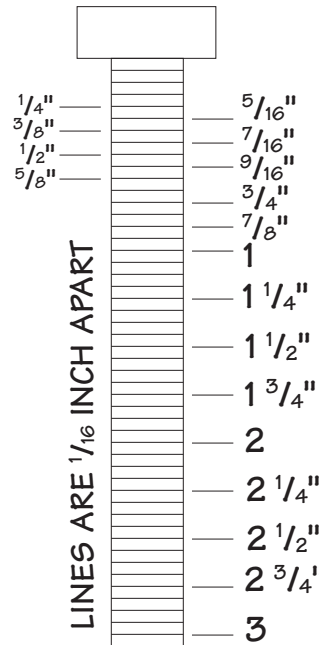
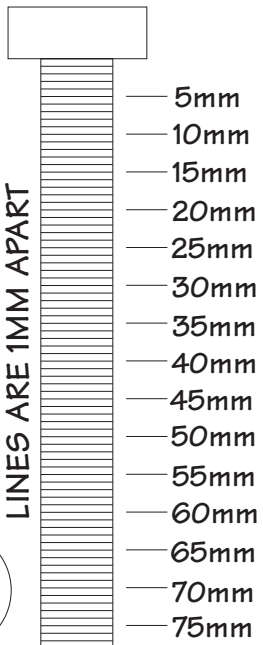

WASHERS ARE MEASURE BY THE INSIDE DIAMETER

Location

Physical Environment

The physical environment where your machine is operated is important for safe operation and longevity of parts. For best results, operate this machine in a dry environment that is free from excessive moisture, hazardous or flammable chemicals, airborne abrasives, or extreme conditions. Extreme conditions for this type of machinery are generally those where the ambient temperature is outside the range of 41°–104°F; the relative humidity is outside the range of 20–95% (non-condensing); or the environment is subject to vibration, shocks, or bumps.

Electrical Installation

Place this machine near an existing power source. Make sure all power cords are protected from traffic, material handling, moisture, chemicals, or other hazards. Make sure to leave access to a means of disconnecting the power source or engaging a lockout/tagout device.

Lighting

Lighting around the machine must be adequate enough to perform operations safely. Shadows, glare, or strobe effects that may distract or impede the operator must be eliminated.

Weight Load

Refer to the **Machine Specifications** for the weight of your machine. Make sure that the surface upon which the machine is placed will bear the weight of the machine, additional equipment that may be installed on the machine, and the heaviest workpiece that will be used. Additionally, consider the weight of the operator and any dynamic loading that may occur when operating the machine.

Space Allocation

Consider the largest size of workpiece that will be processed through this machine and provide enough space around the machine for adequate operator material handling or the installation of auxiliary equipment. With permanent installations, leave enough space around the machine to open or remove doors/covers as required by the maintenance and service described in this manual.

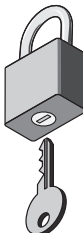
	<p>⚠ CAUTION Children or untrained people may be seriously injured by this machine. Only install in an access restricted location.</p>
--	---

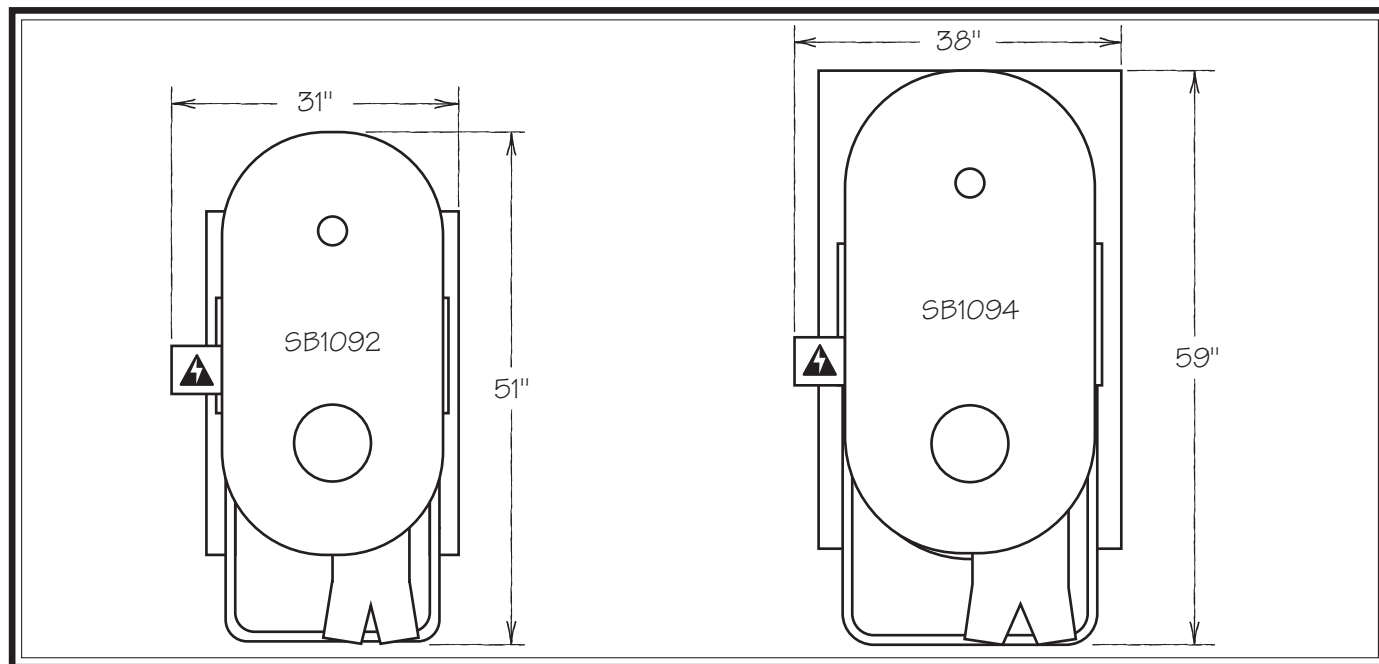

Figure 8. Clearances.

Assembly

The machine must be fully assembled before it can be operated. Before beginning the assembly process, refer to **Needed for Setup** and gather all listed items. To ensure the assembly process goes smoothly, first clean any parts that are covered or coated in heavy-duty rust preventative (if applicable).

To assemble dust collector:

1. Install (2) swivel casters and (2) locking casters on base with (16) $\frac{5}{16}$ "-18 x $\frac{1}{2}$ " flange bolts (see **Figure 9**).

Note: Locking casters install on end of base that sits beneath canister filter.

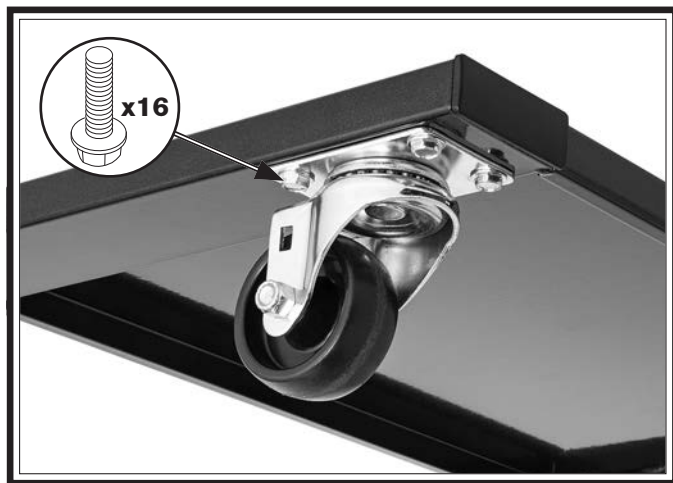

Figure 9. Swivel caster attached to base.

2. Attach side panels to base with $\frac{5}{16}$ "-18 x $\frac{1}{2}$ " flange bolts (see **Figures 10–11**).

Note: Use (6) bolts for SB1092 and (8) bolts for SB1094.

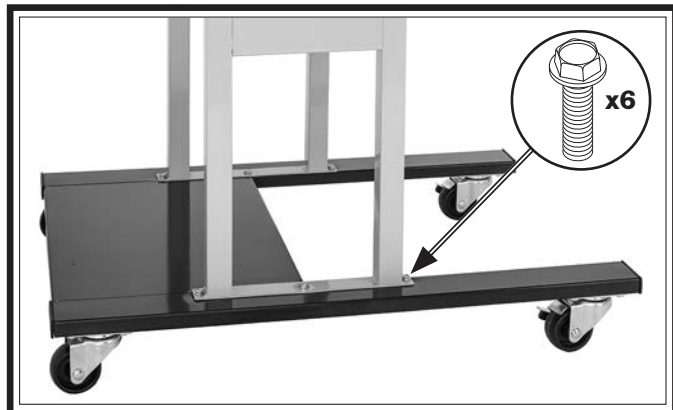

Figure 10. SB1092 side panel attached to base.

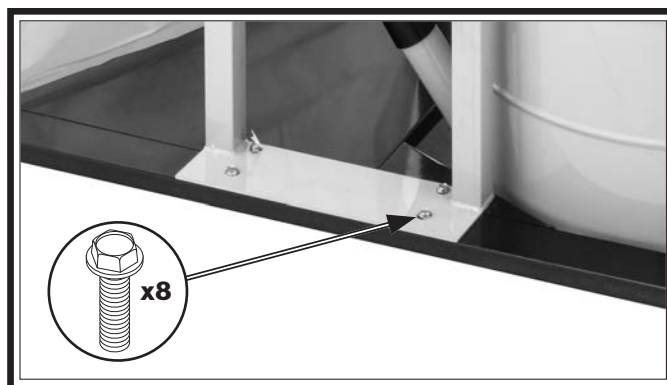

Figure 11. SB1094 side panel attached to base.

3. Attach support panel to side panels with (6) $\frac{5}{16}$ "-18 x $\frac{1}{2}$ " flange bolts (see **Figure 12**).

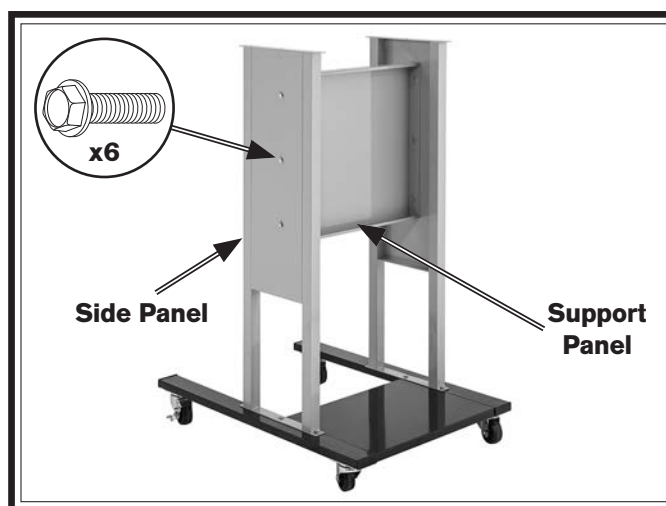

Figure 12. Support panel attached to side panels.

4. Attach switch box mounting plate to main housing with (2) pre-installed screws shown in **Figure 13**.

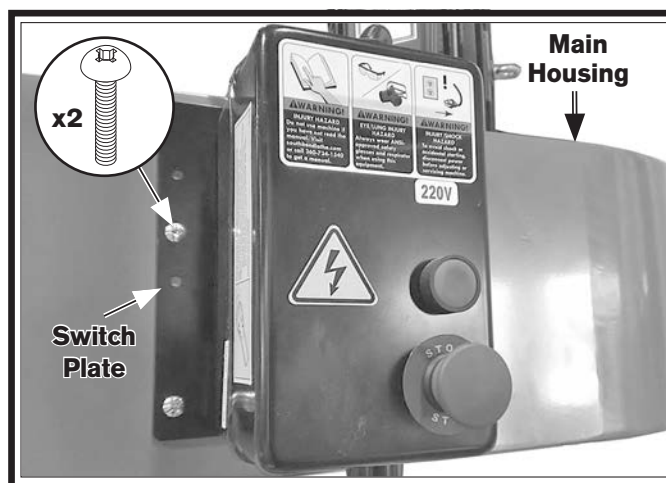
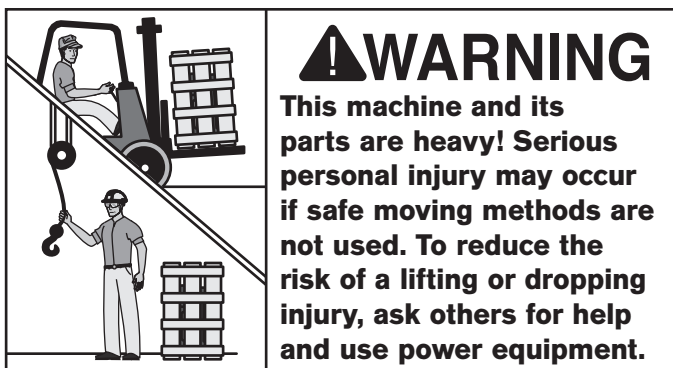

Figure 13. Switch box mounting plate attached to main housing.



5. Use a hoist or forklift with lifting hook through eye bolts to lift housing assembly (see **Figure 14**).

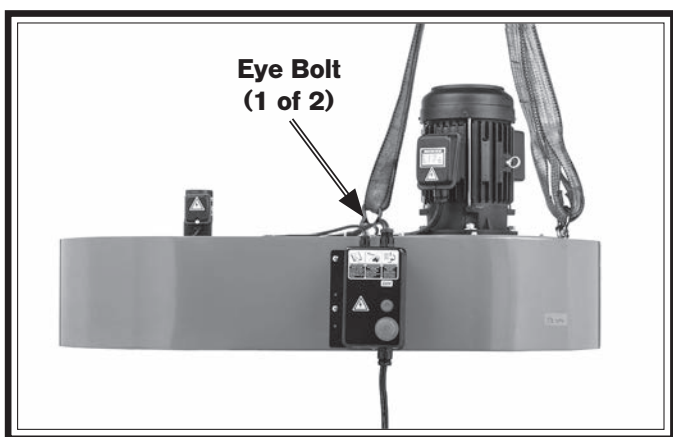

Figure 14. Lifting SB1092 housing assembly.

6. Position housing assembly over side panels and secure with (6) 5/16"-18 x 1/2" flange bolts (see **Figure 15**).

IMPORTANT: *Canister filter side of housing assembly must be over solid side of base.*

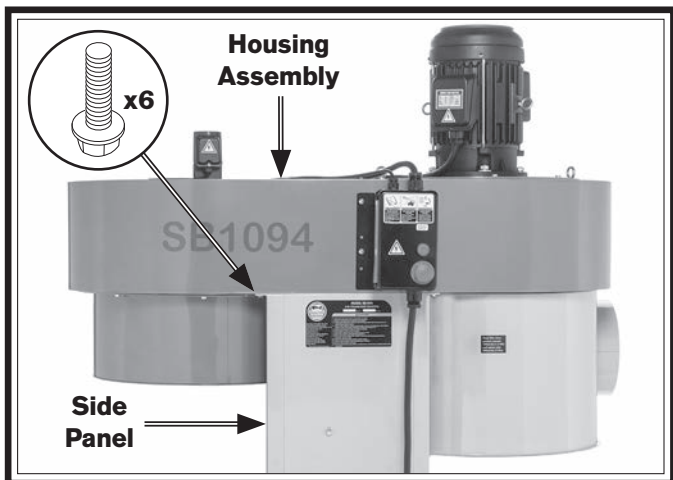

Figure 15. Housing assembly attached to side panels.

7. Install pressure gauge assembly (see **Figure 16**) on side panel with (2) 1/4"-20 x 1/2" flange bolts.
8. Connect pressure gauge tube to hose ports on housing assembly and pressure gauge (see **Figure 16**).
9. Attach 2" hose(s) to hose port(s) on housing assembly with 2" hose clamp(s) (see **Figure 16**).

Note: *Attach (1) hose for SB1092 and (2) hoses for SB1094.*

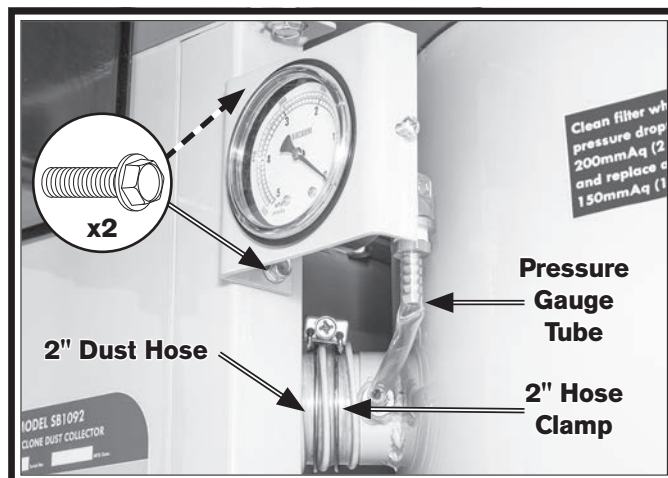

Figure 16. Pressure gauge assembly and 2" dust hose installed.

10. Attach quick connector(s) to open end(s) of 2" hose(s) with 2" hose clamp(s) (see **Figure 17**).

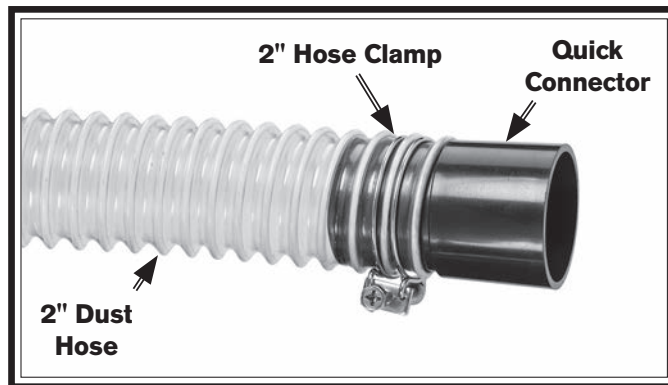

Figure 17. Quick connector attached to dust hose.

11. Attach drum lid to bottom of cone with (6) $\frac{5}{16}$ "-18 x $\frac{1}{2}$ " flange bolts (see **Figure 18**).

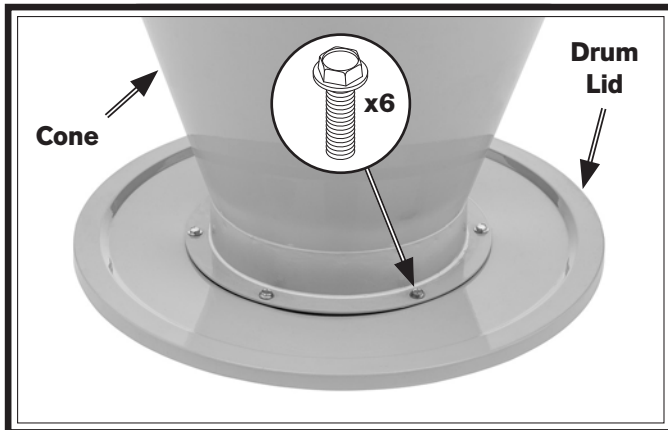

Figure 18. Drum lid attached to cone.

12. Attach cone to housing assembly with cone clamp, then tighten pre-installed hex bolt to secure (see **Figure 19**).

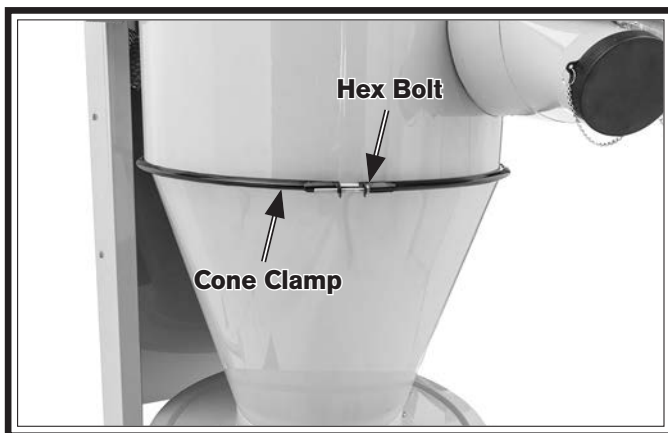

Figure 19. Cone attached to housing assembly.

13. Attach (2) drum lock handle brackets (see **Figure 20**) to side panels with (4) $\frac{1}{4}$ "-20 x $\frac{1}{2}$ " flange bolts.

14. Attach drum lock handle to brackets with (8) M5-.8 x 8 Phillips head screws (see **Figure 20**).

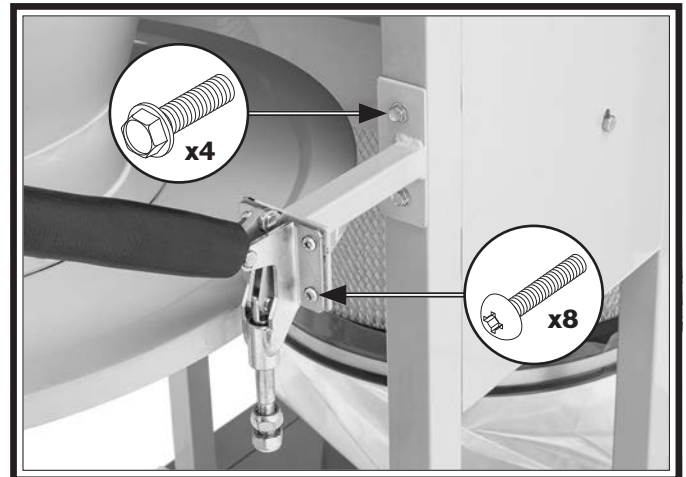

Figure 20. Drum lock handle attached to side panel.

15. Remove pre-installed screw from inlet adapter, then attach inlet adapter to housing assembly and tighten pre-installed screw to secure (see **Figure 21**).

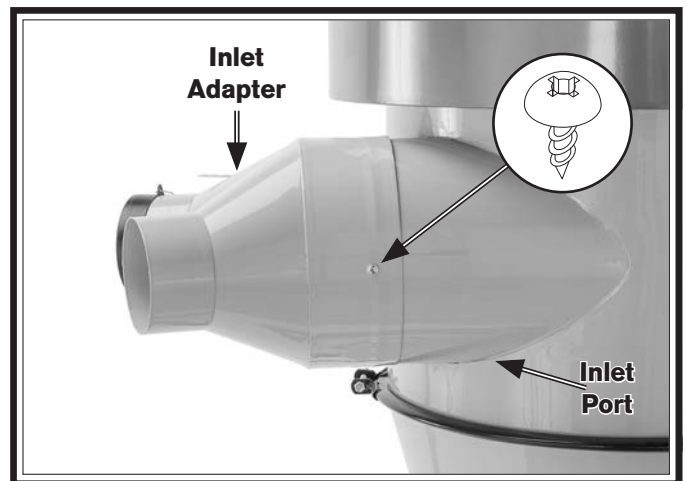
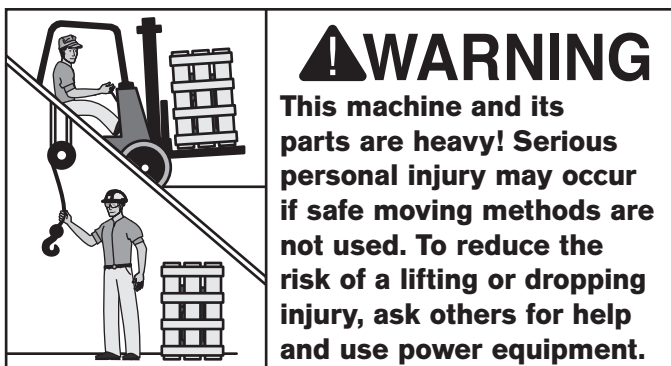

Figure 21. Inlet adapter attached to inlet port.



16. Support canister filter with forklift or jack and position it under housing assembly (see **Figure 22**). Rotate filter so that mounting holes align, then rotate spindle so spindle cap is aligned with motor shaft (see **Figure 23**).

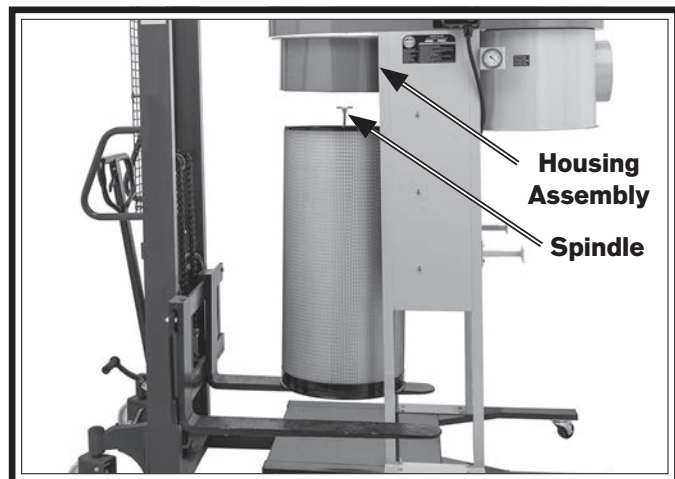

Figure 22. Canister filter in position for mounting.

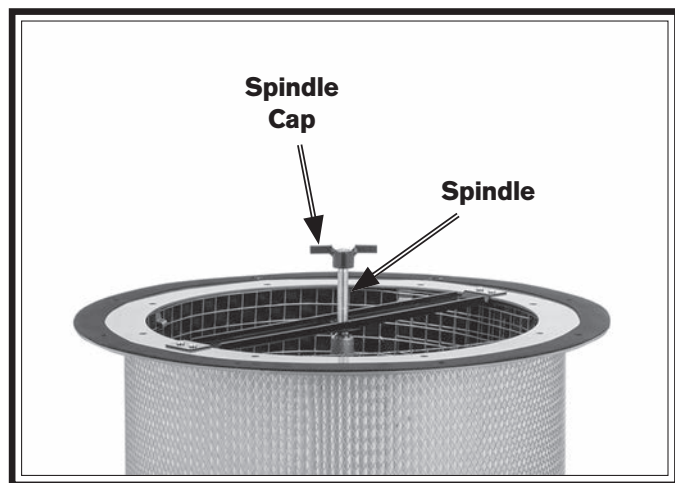

Figure 23. Spindle cap.

17. Attach canister filter to assembly housing with (8) $\frac{5}{16}$ "-18 x $\frac{3}{4}$ " flange bolts (see **Figure 24**).

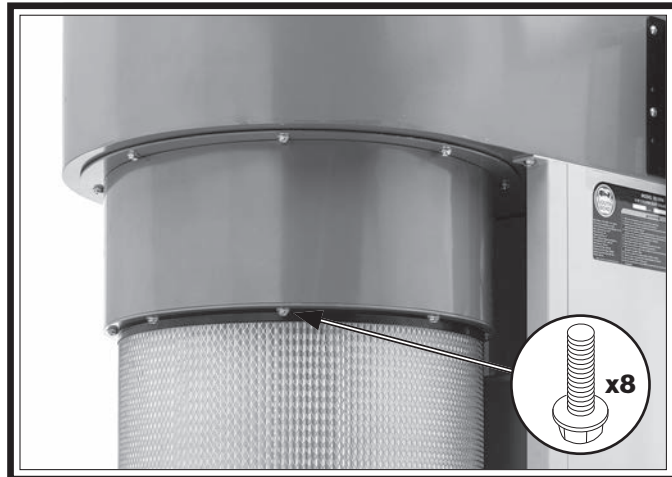

Figure 24. Canister filter attached to housing assembly.

18. Apply $\frac{3}{4}$ " foam tape to bottom rim of canister filter (see **Figure 25**).
19. Attach collection bag to canister filter with bag clamp (see **Figure 25**).

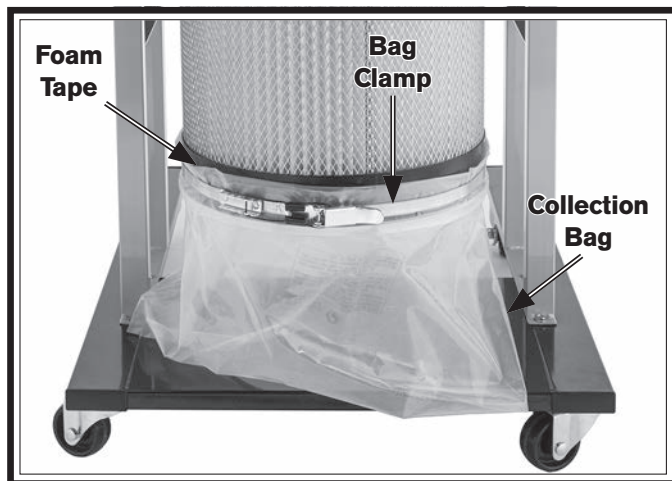

Figure 25. Filter collection bag clamped to filter.

- 20. SB1094 Only:** Attach upper drum to lower drum with drum clamp, then tighten pre-installed hex bolt to secure (see **Figure 26**).
- 21.** Attach left and right drum brackets to drum (see **Figure 26**) with (4) $\frac{5}{16}$ "-18 x $\frac{3}{8}$ " flange bolts.
- Note:** *Notches in brackets should face dust ports.*
- 22.** Attach handle to drum (see **Figure 26**) with (2) $\frac{1}{4}$ "-20 x $\frac{1}{2}$ " flat head screws.

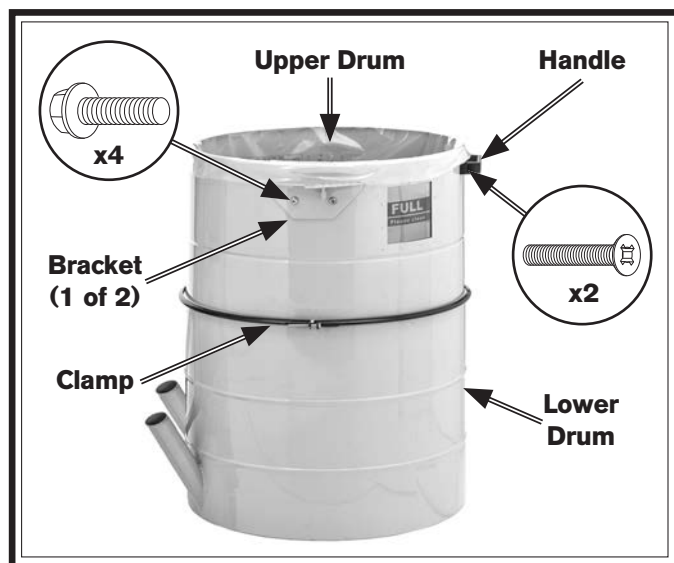

Figure 26. Drum brackets and handle installed (SB1094 shown).

- 23.** Thread (4) drum casters into holes on underside of drum (see **Figure 27**).
- 24.** Connect 2" dust hose(s) with quick connector(s) to lower port(s) of collection drum (see **Figure 27**).

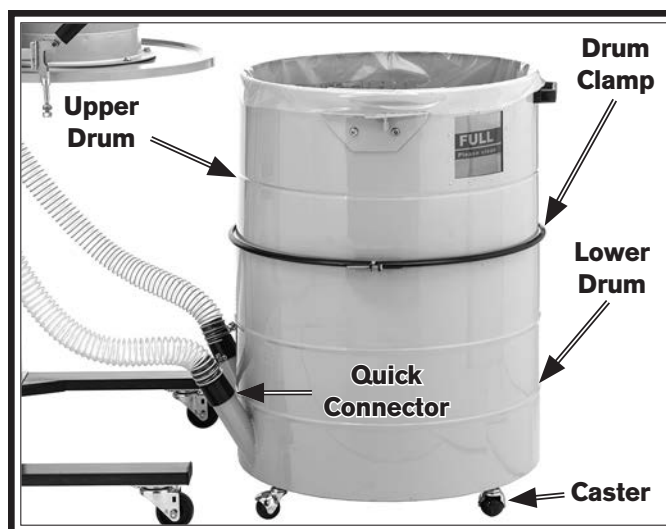

Figure 27. SB1094 collection drum assembled.

- 25.** Place bag inside collection drum, and fold excess over top of drum.
- 26.** Roll drum under lid so that drum brackets slide over lifting hardware, then lower lock handle to lift and seal drum (see **Figure 28**).

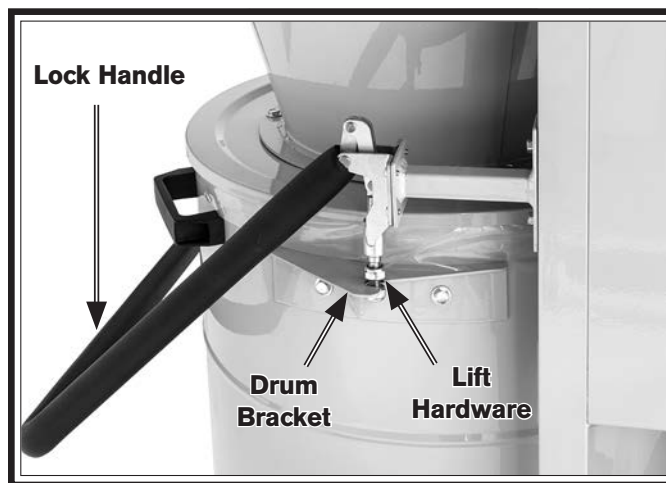

Figure 28. Collection drum secured and sealed by lift hardware.

Power Connection (SB1092)

Before the machine can be connected to the power source, an electrical circuit and connection device must be prepared per the **Power Supply Requirements** section in this manual, and all previous setup instructions in this manual must be complete to ensure that the machine has been assembled and installed properly.

Always make sure the power switch on the machine is turned OFF (or the OFF button is pushed in) before connecting power.

Power Connection

Insert power cord plug into a matching power supply receptacle. The machine is now connected to the power source.

If you need to disconnect the machine from power later, pull the plug completely out of the receptacle.

Power Connection (SB1094)

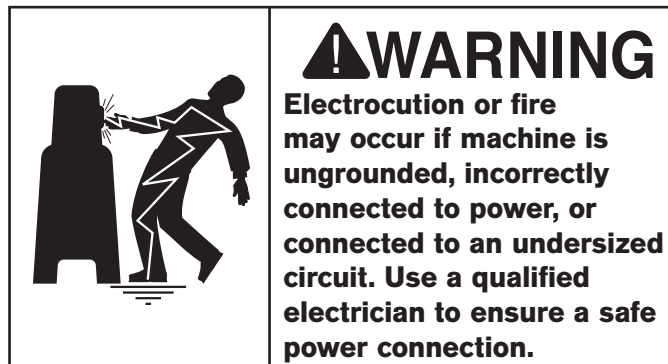

Hardwire setups require power supply lines to be enclosed inside of conduit, which is securely mounted and constructed in adherence to applicable electrical codes.

A hardwire setup for this machine must be equipped with a locking disconnect switch as a means to disconnect the power during adjustments or maintenance, which is a typical requirement for many lock-out/tag-out safety programs.

Figure 29 shows a simple diagram of a hardwire setup with a locking disconnect switch between the power supply and the machine.

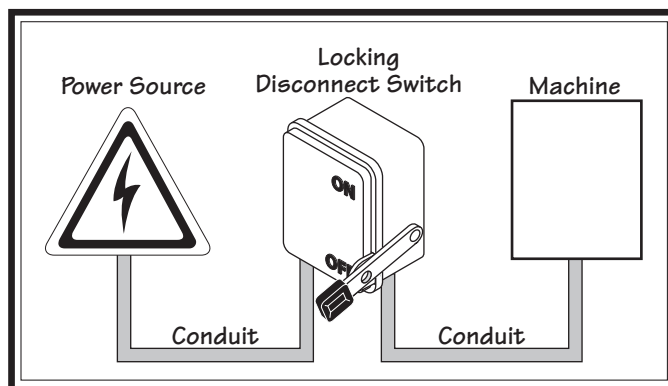

Figure 29. Typical hardwire setup with a locking disconnect switch.

Due to the complexity required for planning, bending, and installing the conduit necessary for a code-compliant hardwire setup, an electrician or other qualified person **MUST** perform this type of installation.

Test Run

After all preparation steps have been completed, the machine and its safety features must be tested to ensure correct operation. If you discover a problem with the operation of the machine or its safety components, do not operate it further until you have resolved the problem.

Note: Refer to **Troubleshooting on Page 40** for solutions to common problems. If you need additional help, contact our Tech Support at (360) 734-1540.

The test run consists of verifying the following:

- Motor powers up and runs correctly.
- Stop button works correctly.
- Remote control works correctly.

WARNING

Serious injury or death can result from using this machine BEFORE understanding its controls and related safety information. DO NOT operate, or allow others to operate, machine until the information is understood.

WARNING

DO NOT start machine until all preceding setup instructions have been performed. Operating an improperly set up machine may result in malfunction or unexpected results that can lead to serious injury, death, or machine/property damage.

To test run machine:

1. Clear all setup tools away from machine.
2. Lock all swivel casters on base.
3. Connect machine to dust-collection system or place covers over inlet adapter ports.

IMPORTANT: *DO NOT operate the dust collector without first connecting it to a dust-collection system or covering an inlet adapter port. Otherwise, the lack of airflow resistance will cause the motor to operate at full amperage load, which could trip your circuit breaker or blow a fuse.*

4. Press STOP button in.
5. Connect machine to power.
6. Standing away from intake port, press green button to turn machine **ON**. Verify motor starts up and runs smoothly without any problems or unusual noises.
7. Press STOP button to turn machine **OFF**.
8. To test remote control operation, press remote ON button to turn motor **ON**. The motor should run smoothly with little or no vibration or rubbing noises.
9. Press remote OFF button to turn motor **OFF**.

— If the machine does start or stop, press Stop button to turn machine **OFF**. Refer to **Pairing Remote Control to Receiver on Page 39** and ensure remote control is paired.

General

⚠ CAUTION

Always make sure there are no open flames or pilot lights in the same room as the dust collector. There is a risk of explosion if too much fine dust is dispersed into the air with an open flame present.



⚠ CAUTION

Always guard against static electrical buildup by grounding all dust collection lines.

The Model SB1092/SB1094 works quite well as a point-of-use dust collector, or for collecting dust from up to two (Model SB1092) or four (Model SB1094) machines simultaneously. The locking swivel casters make it easy to move around the shop near the machine being used.

Tips for Optimum Performance

- Avoid using more than 10' of flexible hose on any ducting line. The ridges inside flexible hose greatly increase static pressure loss, which reduces suction performance.
- Keep ducts between the dust collector and machines as short as possible.
- Keep ducting directional changes to a minimum. The more curved fittings you use, the greater the loss of suction at the dust-producing machine.
- Gradual directional changes are more efficient than sudden directional changes (i.e. use 45° elbows in place of 90° elbows whenever possible).
- The simpler the system, the more efficient and less costly it will be.

Duct Material

You have many choices regarding main line and branch line duct material. For best results, use smooth metal duct for the main line and branch lines, then use short lengths of flexible hose to connect each machine to the branch lines.

Plastic duct is also a popular material for home shops. However, be aware that there is a fire or explosion hazard if plastic duct material is not properly grounded to prevent static electrical buildup (refer to **System Grounding** at the end of this section). Another problem with using plastic duct is that it is less efficient per foot than metal.



⚠ CAUTION

Plastic duct generates static electrical buildup that can cause fire or shock. Properly ground it to reduce this risk.

Plastic Duct

The popularity of plastic duct is due to the fact that it is an economical and readily available product. It is also simple to assemble and easily sealed against air loss. The primary disadvantage of plastic duct for dust collection is the inherent danger of static electrical buildup.



Figure 30. Examples of plastic ducting components.

Metal Duct

Advantages of smooth metal duct are its conductivity, efficiency, and that it does not contribute to static electrical charge build-up. However, static charges are still produced when dust particles strike other dust particles as they move through the duct. Since metal duct is a conductor, it can be grounded quite easily to dissipate any static electrical charges.

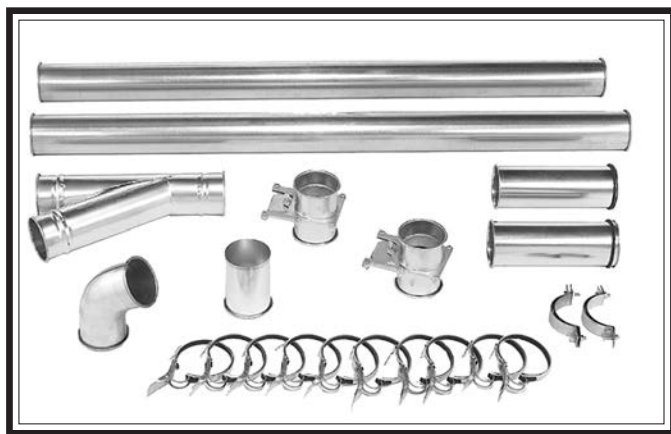

Figure 31. Examples of smooth metal duct and components.

There are a number of options when it comes to metal duct, but metal duct that is specially manufactured for dust collection is the best choice. When selecting your metal duct, choose high quality metal duct with smooth welded internal seams that will minimize airflow resistance. This type of duct usually connects to other ducts or elbows with a simple, self-sealing clamp, is very quick and easy to assemble, and can be readily dismantled and re-installed in a different configuration. This is especially important if you ever need to change things around in your shop or add more tools.

Avoid inferior metal duct that requires you to cut it to length and snap it together. This type of duct is time consuming to install because it requires you to seal all the seams with silicone and screw the components on the ends with sheet metal screws. Another disadvantage is the rough internal seams and crimped ends that unavoidably increase static pressure loss.

Flexible Duct

Flexible hose is generally used for short runs, small shops and at rigid duct-to-tool connections. There are many different types of flex hose on the market today. These are manufactured from materials such as polyethylene, PVC, cloth hose dipped in rubber and even metal, including steel and aluminum.

The superior choice here is metal flex hose that is designed to be flexible, yet be as smooth as possible inside to reduce static pressure loss.

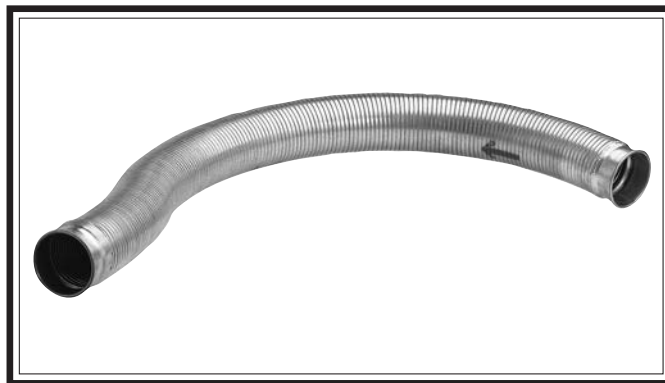

Figure 32. Example of flexible metal duct.

There are also many kinds of pure plastic flexible hose, such as non-perforated drainage type hose and dryer vent hose. Drainage type hose, while being economical, does not quite have the flexibility required for dust collection. The inside of the duct is also deeply corrugated and can increase the static pressure loss by as much as 50% over smooth wall duct. Dryer vent hose, while being completely flexible, is non-resistant to abrasion and has a tendency to collapse in a negative pressure system. We DO NOT recommend using dryer vent hose in your dust collection system.

If using flex-hose, you should choose one of the many types that are designed specifically for the movement of solid particles, i.e. dust, grains, and plastics. However, the cost of specifically designed flexible duct can vary greatly. Grizzly.com offers polyethylene hose, which is well suited for the removal of particulate matter, especially sawdust, since it is durable and completely flexible. Polyethylene is also very economical and available in a wide variety of diameters and lengths for most applications.

System Design

Decide Who Will Design

For most small-to-medium sized shops, you can design and build the dust collection system yourself without hiring engineers or consultants. We have included some basic information here to get you started on a basic design.

If you have a large shop or plan to design a complicated system, we recommend doing additional research beyond this manual or seeking the help of an expert.

Sketch Your Shop Layout

When designing a successful dust collection system, planning is the most important step. In this step, sketch a basic layout of your shop, including space requirements of different machines.

Your sketch only needs the basic details of the shop layout, similar to the figure below, including all your current/planned machines and your planned placement of the dust collector.

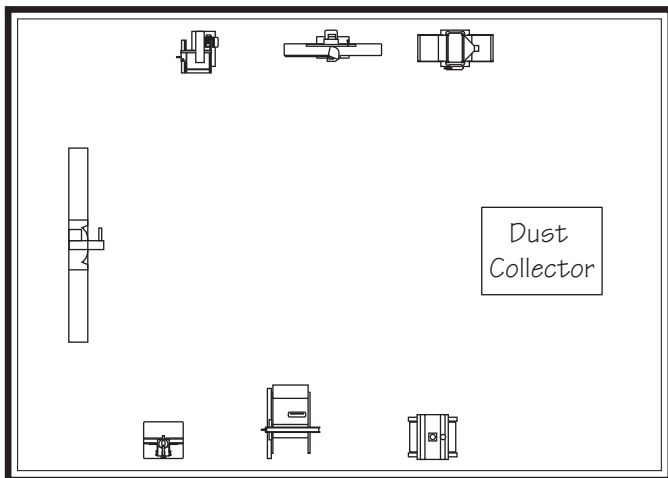

Figure 33. Basic sketch of shop layout.

Sketch a Basic Duct Layout

For the next step, sketch how you will connect your machines to the dust collector. Consider these general guidelines for an efficient system:

1. Machines that produce the most saw dust should be placed nearest to the dust collector (i.e. planers and sanders).
2. Ideally, you should design the duct system to have the shortest possible main line and secondary branch ducts. See the figures below for ideas of efficient versus inefficient duct layouts.

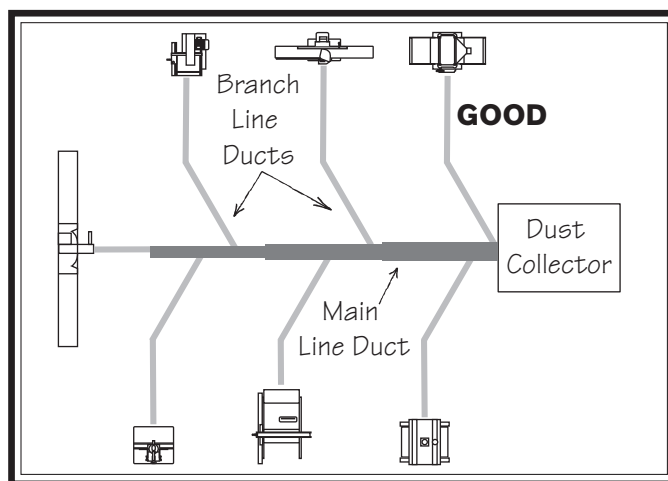

Figure 34. Efficient duct layout.

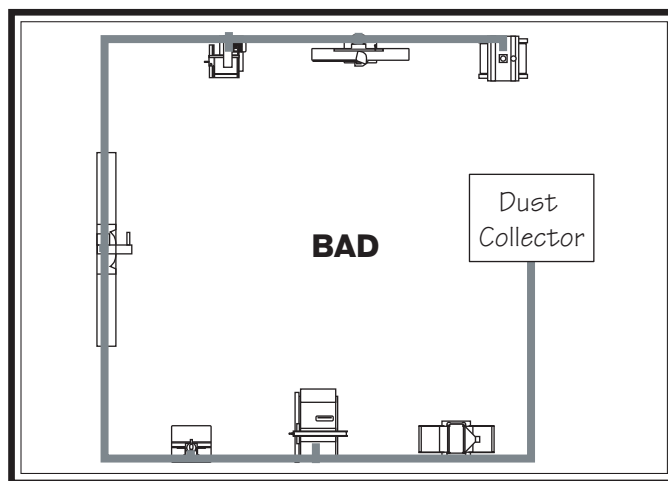

Figure 35. Inefficient duct layout.

3. Directional changes should be kept to a minimum. The more directional change fittings you use directly increases the overall resistance to airflow.

4. Gradual directional changes are more efficient than sudden directional changes (i.e. use the largest corner radius possible when changing hose or pipe direction).
5. Each individual branch line should have a blast gate immediately after the branch to control suction from one machine to another.
6. The simpler the system, the more efficient and less costly it will be.

Determine Required CFMs

Since each machine produces a different amount of sawdust, the requirements for the minimum amount of CFM to move that sawdust is unique to the machine (for example, a planer produces more sawdust than a table saw). Knowing this required CFM is important to gauging which size of duct to use.

Refer to the figure below for a close estimation of the airflow each machine requires. Keep in mind that machines that generate the most sawdust should be placed closest to the dust collector. If the machine has multiple dust ports, the total CFM required is the sum of all ports.

Machine Dust Port Size	Approximate Required CFM
2"	100
2.5"	150
3"	250
4"	400
5"	600
6"	850
7"	1200
8"	1600
9"	2000
10"	2500

Figure 36 . Approximate required air flow for machine, based on dust port size.

If the machine does not have a built-in dust port, use the following table to determine which size of dust port to install.

Machine	Average Dust Port Size
Table Saw	4"
Miter/Radial-Arm Saw.....	2"
Jointer (6" and smaller)	4"
Jointer (8"-12")	5"
Thickness Planer (13" and smaller)	4"
Thickness Planer (14"-20")	6"
Shaper.....	4"
Router (mounted to table).....	2"
Bandsaw	4"
Lathe.....	4"
Disc Sander (12" and smaller).....	2"
Disc Sander (13-18")	4"
Belt Sander (6" and smaller)	2"
Belt Sander (7"-9")	3"
Edge Sander (6" x 80" and smaller)	4"
Edge Sander (6" x 80" and larger).....	5"
Drum Sander (24" and smaller)	2 x 4"
Drum Sander (24" and larger).....	4 x 4"
Widebelt Sander (18" and smaller)	5"
Widebelt Sander (24"-37" single head)	2 x 6"
Widebelt Sander (24"-51" double head)	5 x 4"

Figure 37. Dust port size and quantity per average machine.

Write the required CFM for each machine on your sketch, as shown in the figure below.

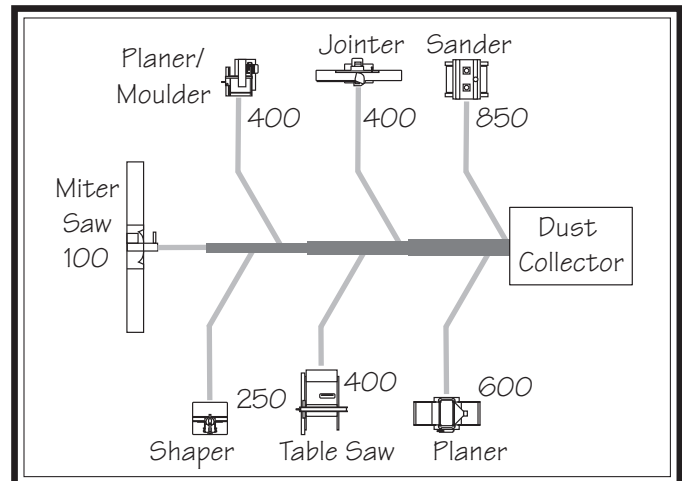

Figure 38. CFM requirements labeled for each machine.

Determine Main Line Duct Size

The general rule of thumb for a main line duct is that the velocity of the airflow must not fall below 3500 FPM.

For small/medium sized shops, using the inlet size of the dust collector as the main line duct size will usually keep the air velocity above 3500 FPM and, depending on your system, will allow you to keep multiple branches open at one time.

Mark your drawing, as shown in the figure below, but using the inlet size for your dust collector as the main line.

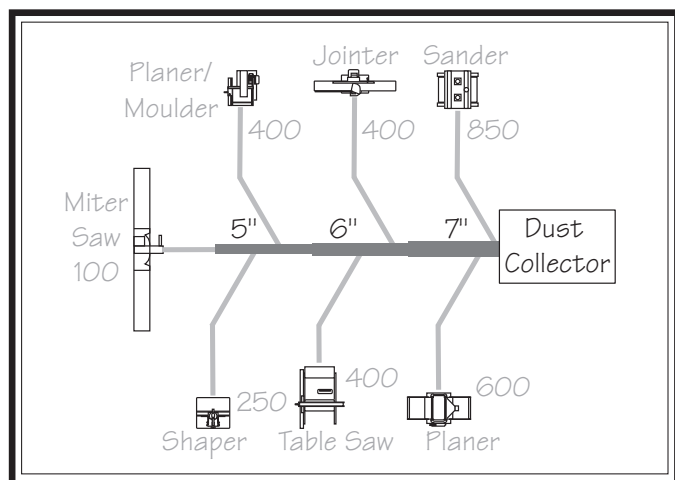

Figure 39. Main line size labeled on sketch.

Determine Branch Line Duct Size

The general rule of thumb for a branch line duct is that the velocity of the airflow must not fall below 4000 FPM.

For small/medium sized shops, using the dust port size from the machine as the branch line duct size will achieve the correct velocity in most applications. However, if the dust port on the machine is smaller than 4", make the branch line 4" and neck the line down right before the dust port.

Note: *Systems with powerful dust collectors work better if multiple blast gates are left open. This also allows you to run two machines at once. Experiment with different combinations of blast gates open / closed to find the best results for your system.*

Write your determined branch line sizes on your drawing, as shown in the following figure.

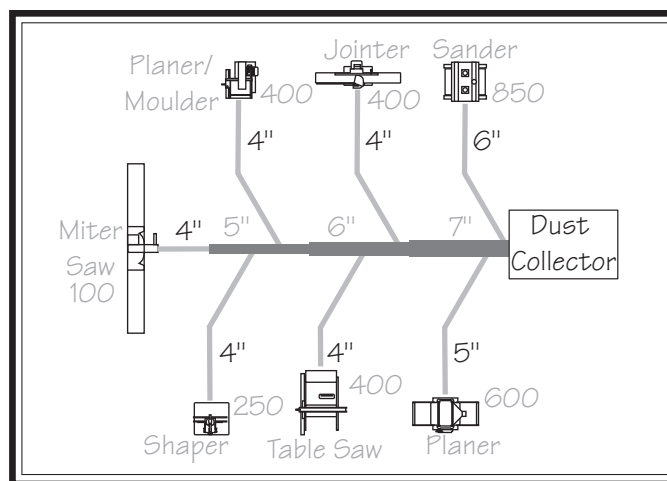

Figure 40. Branch line duct sizes labeled.

If two machines will connect to the same branch line and both will operate at the same time, then add the required CFM for each machine together and find the closest total CFM in the table below to determine the correct branch size.

If both machines will never run at the same time, reference the machine with the biggest dust port in the table below and add blast gates after the Y-branch to open/close the line to each machine.

Total CFM	Branch Line Size
400	4"
500	4"
600	5"
700	5"
800	6"
900	6"
1000	6"

Figure 41. Sizing chart for multiple machines on the same branch line.

Planning Drop Downs

Plan the drop downs for each machine, using blast gates wherever possible to control airflow.

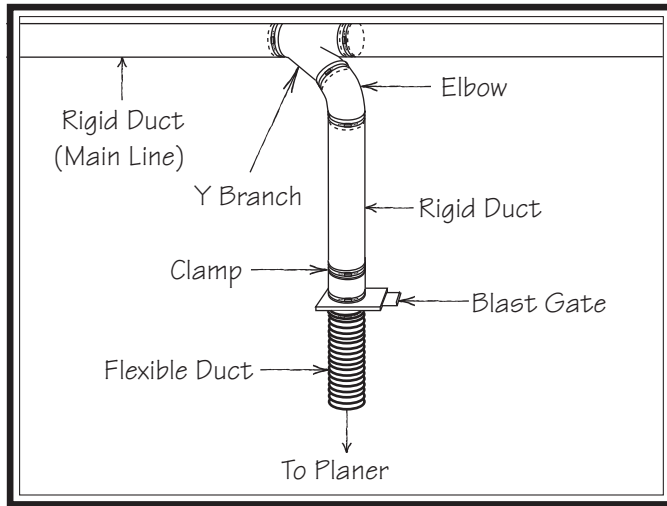

Figure 42. Drop-down setup.

Calculating Duct Resistance

Adding duct work, elbows, branches and any other components to a duct line increases airflow resistance (static pressure loss). This resistance can be minimized by using rigid (smooth) duct and gradual curves, as opposed to flexible duct and 90° elbows.

To help you think about this resistance, imagine riding a bicycle in a tunnel that is an exact replica of your duct work. If the inside of the tunnel is very bumpy (flexible duct) and has a lot of sharp turns (90° elbows), it will take a lot more effort to travel from one end to the other.

The purpose of calculating the resistance is to determine if it is low enough from the machine to the dust collector to meet the given CFM requirement for the machine. Use the following tables to calculate the resistance of duct work.

Duct Dia.	Approximate Static Pressure Loss Per Foot of Rigid Duct		Approximate Static Pressure Loss Per Foot of Flexible Duct	
	Main Lines at 3500 FPM	Branch Lines at 4000 FPM	Main Lines at 3500 FPM	Branch Lines at 4000 FPM
2"	0.091	0.122	0.35	0.453
2.5"	0.08	0.107	0.306	0.397
3"	0.071	0.094	0.271	0.352
4"	0.057	0.075	0.215	0.28
5"	0.046	0.059	0.172	0.225
6"	0.037	0.047	0.136	0.18
7"	0.029	0.036	0.106	0.141
8"	0.023	0.027	0.08	0.108
9"	0.017	0.019	0.057	0.079

Fitting Dia.	90° Elbow	45° Elbow	45° Wye(Y)	90° Wye(Y)
3"	0.47	0.235	0.282	0.188
4"	0.45	0.225	0.375	0.225
5"	0.531	0.266	0.354	0.236
6"	0.564	0.282	0.329	0.235
7"	0.468	0.234	0.324	0.216
8"	0.405	0.203	0.297	0.189

Figure 43. Static pressure loss charts.

In most small/medium shops it is only necessary to calculate the line with the longest duct length or the most fittings (operating under the assumption that if the line with the highest resistance works, the others will be fine).

To calculate the static pressure of any given line in the system, follow these steps:

1. Make a list of each size duct in the line, including the length, and multiply those numbers by the static pressure value given in the previous table.
2. List each type of elbow or branch and multiply the quantity (if more than one) by the static pressure loss given in the previous table.

3. Add the additional factors from the following table to your list.

Additional Factors	Static Pressure
Seasoned (well used) Dust Collection Filter	1"
Entry Loss at Large Machine Hood	2"

Figure 44. Additional factors affecting static pressure.

4. Total your list as shown in the example below to come up with your overall static pressure loss number for that line.

Note: Always account for a seasoned filter, so you don't end up with a system that only works right when the filter is clean.

Main Line	
6" Rigid Duct (0.037) at 20'	0.740
Branch Line	
4" Rigid Duct (0.075) at 10'	0.750
4" Flexible Duct (0.28) at 5'	1.400
Elbows/Branches	
6" 45° Y-Branch	0.329
4" 45° Elbow	0.225
Additional Factors	
Seasoned Filter	1.000
Total Static Pressure Loss	4.444

Figure 45. Totaling static pressure numbers.

Note: When calculating static pressure loss to determine if multiple lines can be left open at the same time, only include the main line numbers once.

5. Compare the total static pressure loss for that line to the closest CFM given on the performance curve for your dust collector.

Example: A typical Data Sheet Performance Curve is illustrated in the figure below. Find the total static pressure loss on the Static Pressure axis (4.4 in the current example), then refer to the closest value on the CFM axis—approximately 1120 CFM.

The 1120 CFM for the static pressure loss of the line connected to the router is well above the 220 CFM requirement of that machine.

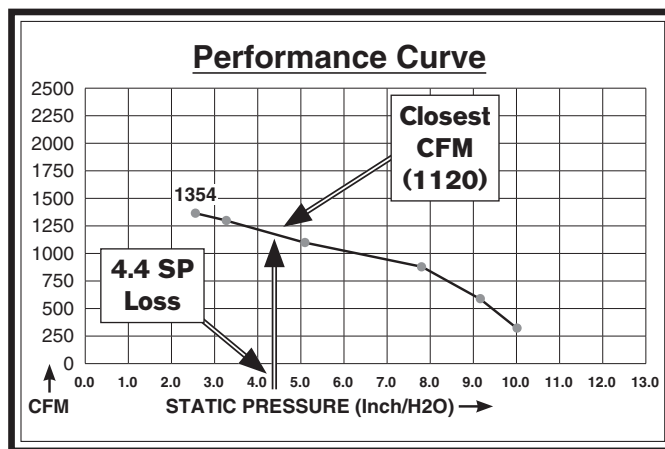

Figure 46. CFM for static pressure loss of line connected to a dust collector and router.

- If the CFM for your static pressure loss is above the requirement of the machine connected to the end of that branch line, then dust collection will most likely be successful. Congratulations! You've just designed your own dust system. Refer to the **Accessories** section of this manual to start buying the components necessary to make your system a reality.
- If the CFM for your static pressure loss is below the requirement of the machine, then that line will not effectively collect the dust. You must then modify some of the factors in that line to reduce the static pressure loss. Some of the ways to do this include 1) installing larger duct, 2) reducing amount of flexible duct used, 3) increasing machine dust port size, 4) moving machine closer to dust collector to eliminate duct length, and 5) reducing 90° elbows or replacing them with 45° elbows.

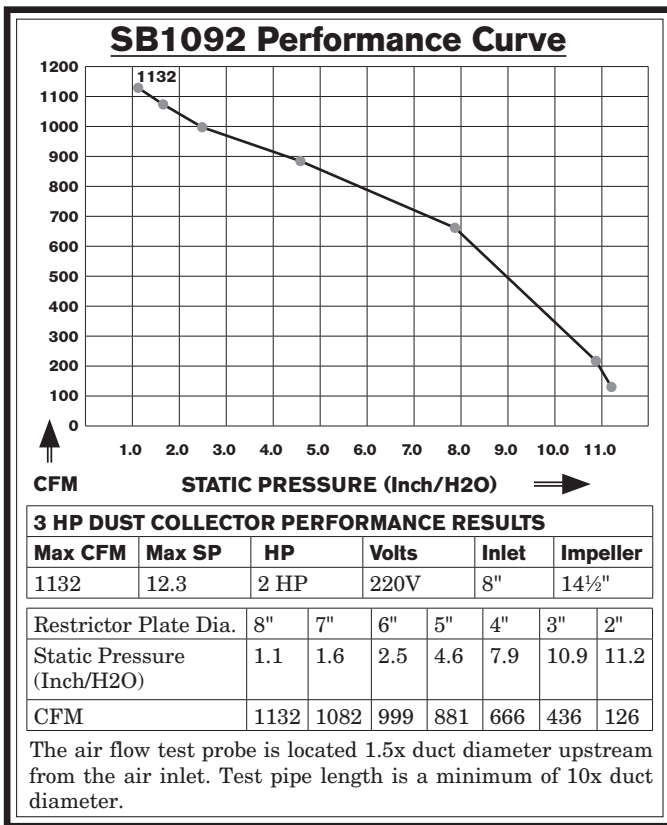

Figure 47. SB1092 performance data.

Example Materials List

After the system is designed, create a materials list of all the items you will need to build your dust collection system. This will make it easy when it comes time to purchase the materials.

Below is an example of some items that might be needed.

Description	Model	Quantity
6" Rigid Duct at 20'	G7364	4
4" Rigid Duct at 10'	G6162	2
4" Flex Hose at 5'	H7215	6
6" 45° Y-Branch	G7353	6
4" 45° Elbow	G6167	6

Figure 49. Example materials list.

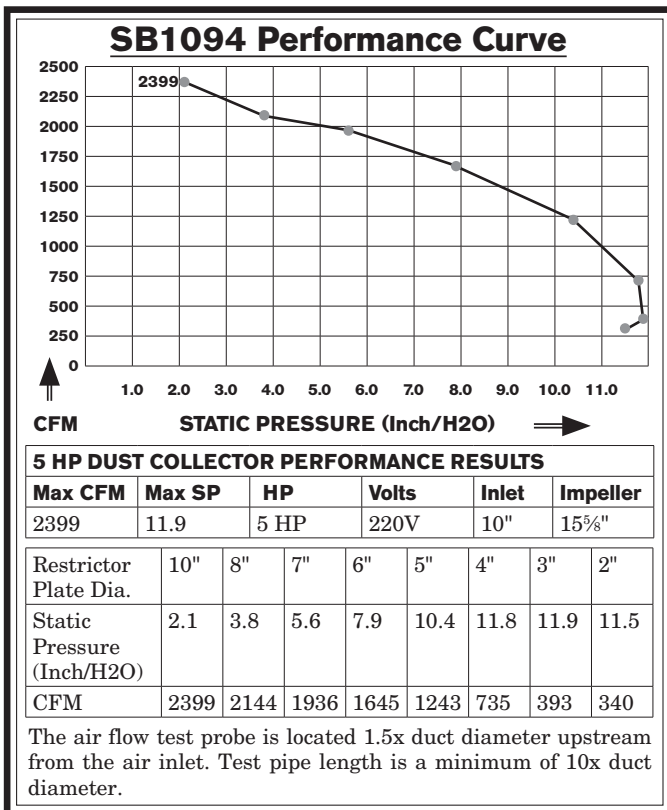

Figure 48. SB1094 performance data.

System Grounding

Since plastic hose is abundant, relatively inexpensive, easily assembled and air tight, it is a very popular material for conveying dust from woodworking machines to the dust collector.

We recommend only using short lengths of flexible hose (flex-hose) to connect the woodworking machine to the dust collector. However, plastic flex-hose and plastic duct are an insulator, and dust particles moving against the walls of the plastic duct create a static electrical buildup. This charge will build until it discharges to a ground.

If a grounding medium is not available to prevent static electrical buildup, the electrical charge will arc to the nearest grounded source. This electrical discharge may cause an explosion and subsequent fire inside the system.

To protect against static electrical buildup inside a non-conducting duct, a bare copper wire should be placed inside the duct along its length and grounded to the dust collector. You must also confirm that the dust collector is continuously grounded through the electrical circuit to the electric service panel.

If you connect the dust collector to more than one machine by way of a non-conducting branching duct system and blast gates, the system must still be grounded as mentioned above. We recommend inserting a continuous bare copper ground wire inside the entire duct system and attaching the wire to each grounded woodworking machine and dust collector.



Be sure that you extend the bare copper wire down all branches of the system. Do not forget to connect the wires to each other with wire nuts when two branches meet at a “Y” or “T” connection.

Ensure that the entire system is grounded. If using plastic blast gates to direct air flow, the grounding wire must be jumped (see the figure below) around the blast gate without interruption to the grounding system.

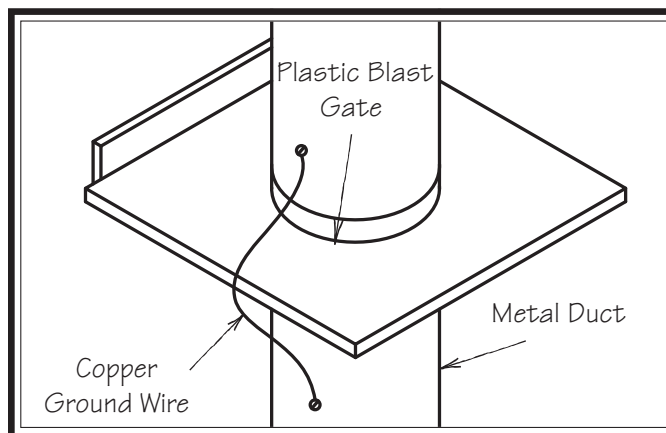

Figure 50. Ground jumper wire when using plastic blast gates and metal duct.

We also recommend wrapping the outside of all plastic ducts with bare copper wire to ground the outside of the system against static electrical buildup. Wire connections at Y's and T's should be made with wire nuts.

Attach the bare ground wire to each stationary woodworking machine and attach to the dust collector frame with a ground screw as shown in the figure below. Ensure that each machine is continuously grounded to the grounding terminal in your electric service panel.

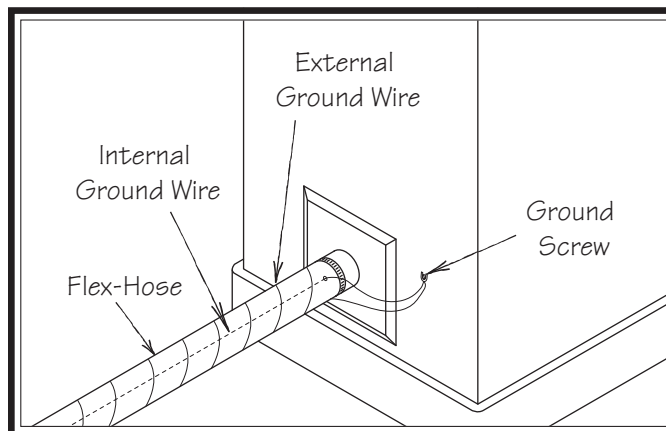
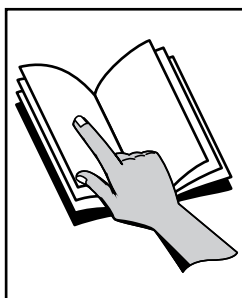

Figure 51. Flex-hose grounded to machine.

Operation Overview

The purpose of this overview is to provide the novice machine operator with a basic understanding of how the machine is used during operation, so they can more easily understand the controls discussed later in this manual.

Note: Due to the generic nature of this overview, it is not intended to be an instructional guide for performing actual machine operations. To learn more about specific operations and machining techniques, seek training from people experienced with this type of machine, and do additional research outside of this manual by reading "how-to" books, trade magazines, or websites.



!WARNING

To reduce the risk of serious injury when using this machine, read and understand this entire manual before beginning any operations.

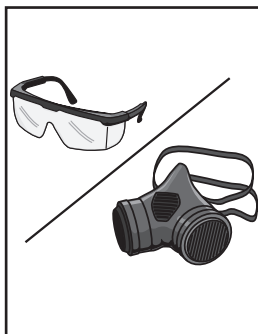

!WARNING

During operation, small wood chips and dust may become airborne, leading to serious eye injury or lung damage. Wear safety glasses and a respirator to reduce this risk.

General Operation

This cyclone dust collector creates a vortex of incoming air that extracts heavy wood chips and large dust particles, and then drops them into the steel drum below, which is lined with a plastic bag.

The remaining fine dust travels past the impeller and is then caught by a canister filter and deposited in the plastic collection bag below. The spun bond polyester filters catch 80 percent of particles 1 micron in size, and are pleated to provide maximum surface area for efficient air flow.

To maintain CFM after heavy use, the automatic filter brush knocks caked-on dust into the collection bag when the machine is turned **OFF**.

To complete a typical operation, the operator does the following:

1. Locks dust collector swivel casters.
2. Closes blast gates to direct vacuum pressure to desired machine.
3. Turns woodworking machine **ON**.
4. Turns dust collector **ON**.
5. Performs woodworking operation.
6. Turns woodworking machine **OFF**.
7. Turns dust collector **OFF**.

Accessories

⚠ WARNING

Installing unapproved accessories may cause machine to malfunction, resulting in serious personal injury or machine damage. To reduce this risk, only install accessories recommended by South Bend or Grizzly.

NOTICE

Refer to Grizzly's website or latest catalog for additional recommended accessories.

This section includes the most common accessories available for your machine, which are available through our exclusive dealer, Grizzly Industrial, Inc., at grizzly.com.

- D4206**—Clear Flexible Hose 4" x 10'
- D4256**—45° Elbow 4"
- W1034**—Heavy-Duty Clear Flex Hose 4" x 10'
- D2107**—Hose Hanger 4 1/4"
- W1015**—Y-Fitting 4" x 4" x 4"
- W1017**—90° Elbow 4"
- W1019**—Hose Coupler (Splice) 4"
- W1317**—Wire Hose Clamp 4"
- W1007**—Plastic Blast Gate 4"
- W1053**—Anti-Static Grounding Kit



Figure 52. 4" dust-collection accessories.

- G6177**—4" Metal Blast Gate
- G7340**—5" Metal Blast Gate
- G7358**—6" Metal Blast Gate
- H5234**—7" Metal Blast Gate
- H5249**—8" Metal Blast Gate

Control air flow and resistance between machines. These industrial blast gates can take the abuse of thousands of open and close cycles. Made specifically for production shops. These metal industrial dust collection fittings are simply the best you can find.

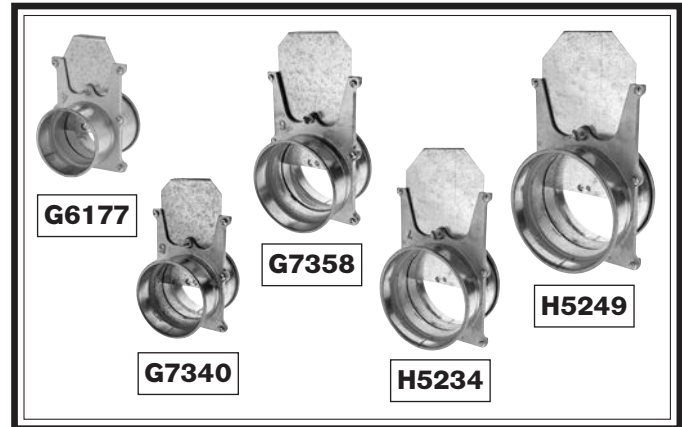

Figure 53. Metal blast gate assortment.

T27422—Viewing Spool 8"

This viewing spool is a section of acrylic glass with QF ends so you can keep an eye on your material flow. Makes it a cinch to check for slow-downs or debris! Ends are 22 gauge, 8" opening. Total length 12.5".



Figure 54. T27422 Viewing Spool.

order online at www.grizzly.com or call 1-800-523-4777

H5293—4" Metal Duct Starter Kit**H5295—5" Metal Duct Starter Kit****H5297—6" Metal Duct Starter Kit**

Save over 20% with this great starter kit. Includes: (2) machine adapters, (10) pipe clamps, (3) 5' straight pipes, (1) branch, (3) pipe hangers, (1) end cap, (3) adjustable nipples, (1) 90° elbow, and (1) 60° elbow.

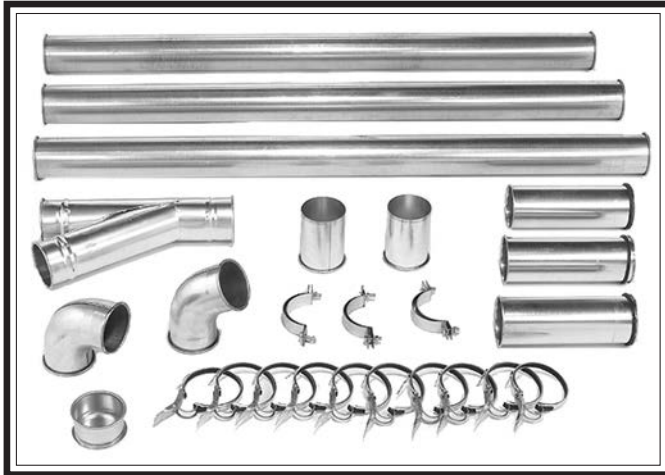

Figure 55. Metal Duct Starter Kit.

H5294—4" Metal Duct Machine Addition Kit**H5296—5" Metal Duct Machine Addition Kit****H5298—6" Metal Duct Machine Addition Kit**

Save over 20% with this great machine addition kit. Includes: (2) blast gates, (1) machine adapter, (10) pipe clamps, (2) pipe hangers, (2) 5' straight pipes, (2) adjustable nipples, (1) branch, and (1) 60° elbow.

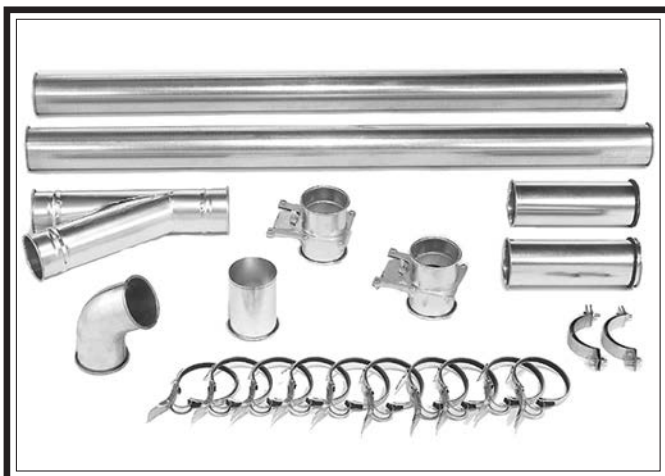

Figure 56. Metal Duct Machine Addition Kit.

SB1105—Replacement Filter (SB1092)**SB1107—Replacement Filter (SB1094)**

Figure 57. Replacement filter canisters.

T27900—Filter Collection Bag 20" x 23"**SB1104—Drum Collection Bag 19½" x 32¹¹/₁₆" (SB1092)****SB1106—Drum Collection Bag 24½" x 47¹/₄" (SB1094)**

Figure 58. Replacement collection bags.

order online at www.grizzly.com or call 1-800-523-4777

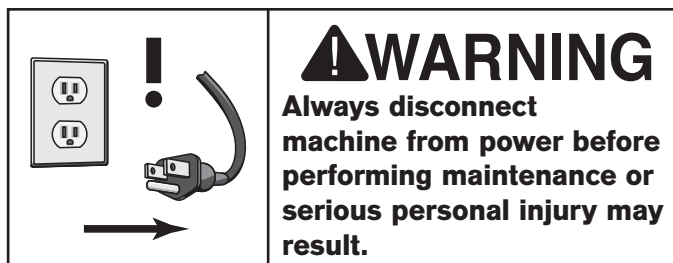

Maintenance Schedule

For optimum performance from your machine, follow this maintenance schedule and refer to any specific instructions given in this section.

Ongoing

To minimize your risk of injury and maintain proper machine operation, shut down the machine immediately if you ever observe any of the items below, and fix the problem before continuing operations:

- Loose mounting bolts.
- Damaged filter canister, cleaning paddle components, or collection bags.
- Worn or damaged wires.
- Suction leaks.
- Any other unsafe condition.

Monthly Check

- Clean/vacuum dust buildup off machine body and motor.

Semi-Annual/Annual Check (Depending on Frequency of Use)

- Replace canister filter.

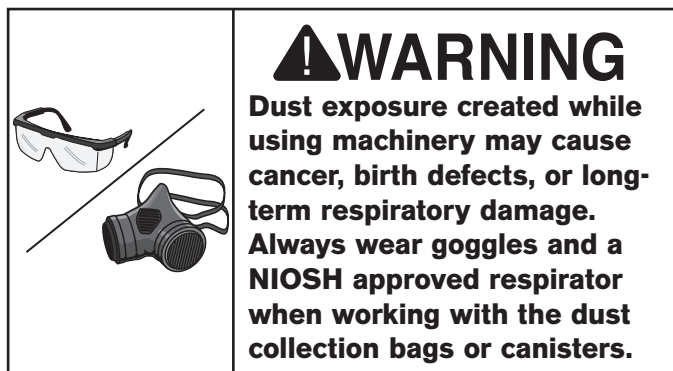

Cleaning Canister Filter

This dust collector uses an automatic filter brush to remove dust buildup and debris from the filter pleats. The system will turn **ON** for approximately 90 seconds after the machine is turned **OFF** to clean the canister filter and knock dust cake into the filter bag.

If operating pressure on pressure gauge drops below 200mmAq, remove canister filter and gently knock dust from pleats (refer to **Removing/Replacing Canister Filter** on **Page 38**). If operating pressure reaches 150mmAq and cleaning does not improve performance, replace the filter.

IMPORTANT: *DO NOT use water or high pressure to clean canister filter. Doing so will damage the filter and reduce filtration.*

Dispose of the filter collection bag when dust fills it about $\frac{1}{2}$ full (see **Removing/Replacing Filter Collection Bag** on **Page 37**).

IMPORTANT: *To contain wood dust and minimize risk of exposure, firmly tie bag closed.*

Removing/Replacing Drum Collection Bag

Dispose of the drum bag when dust fills it $\frac{3}{4}$ full. Replace the bag if it develops a leak or becomes damaged.

Items Needed	Qty
SB1104 Drum Collection Bag (SB1092).....	1
SB1106 Drum Collection Bag (SB1094).....	1

To remove and replace collection drum bag:

1. DISCONNECT MACHINE FROM POWER!
2. Lift drum lock handle to lower collection drum onto casters then roll drum out from under drum lid (see **Figure 59**).

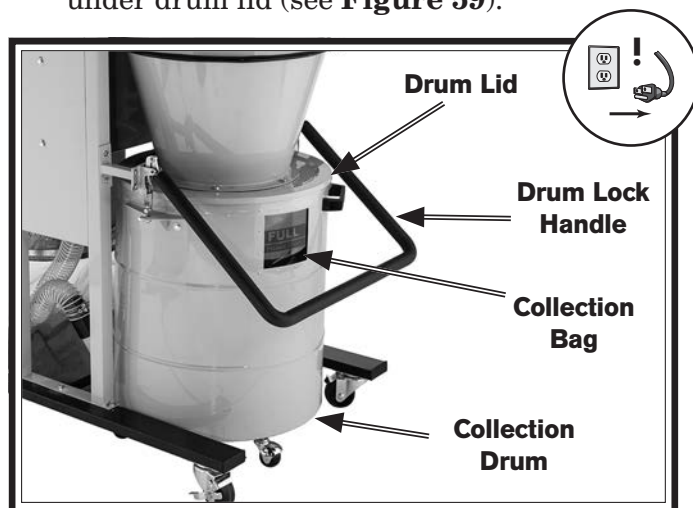

Figure 59. Drum collection bag components.

3. Lift collection bag out of drum, firmly tie closed, then dispose of contents.

IMPORTANT: *To contain wood dust and minimize risk of exposure, tie bag closed before disposal.*

4. Place new collection bag inside collection drum, and fold excess bag length over top of drum.
5. Move collection drum under lid and latch it closed.
6. Press drum lock handle down to lift collection drum off casters for operation.

Removing/Replacing Filter Collection Bag

Remove and replace the filter collection bag when it is about $\frac{1}{2}$ full.

Items Needed	Qty
T27900 Filter Collection Bag.....	1

To remove and replace filter collection bag or bags:

1. DISCONNECT MACHINE FROM POWER!
2. Release bag clamp around bottom of canister filter, then remove filter collection bag (see **Figure 60**).

IMPORTANT: *To contain wood dust and minimize risk of exposure, tie bag closed before disposal.*

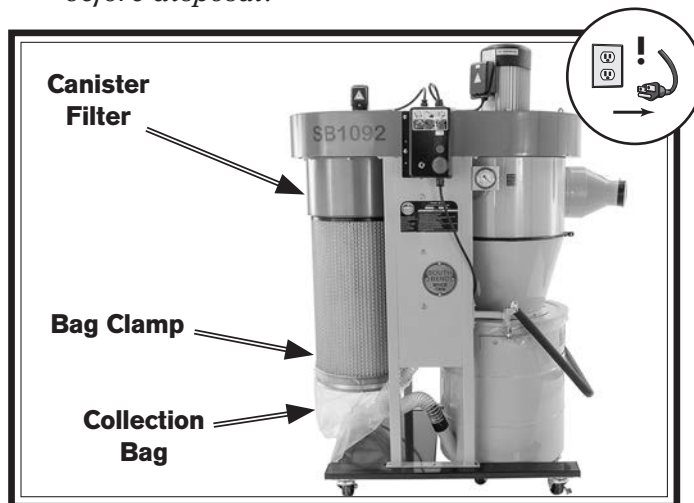

Figure 60. Filter collection bag components.

3. Attach new filter collection bag around bottom of canister filter and secure with clamp.

Removing/Replacing Canister Filter

If the canister filter is clogged or dirty and cleaning or washing it does not improve dust-collection performance, the canister filter must be replaced.

Items Needed	Qty
An Assistant	1
Safety Glasses (Per Person).....	1
Wrench or Socket, 12mm.....	1
Wrench or Socket, 10mm.....	1
Shop Vac.....	1
Forklift or Jack.....	1
SB1105 Canister Filter (SB1092).....	1
SB1107 Canister Filter (SB1094).....	1
T27900 Filter Collection Bag.....	1

To remove and replace canister filter:

1. DISCONNECT MACHINE FROM POWER!
2. Release bag clamp, then remove filter collection bag (see **Figure 61**). Tie bag closed.

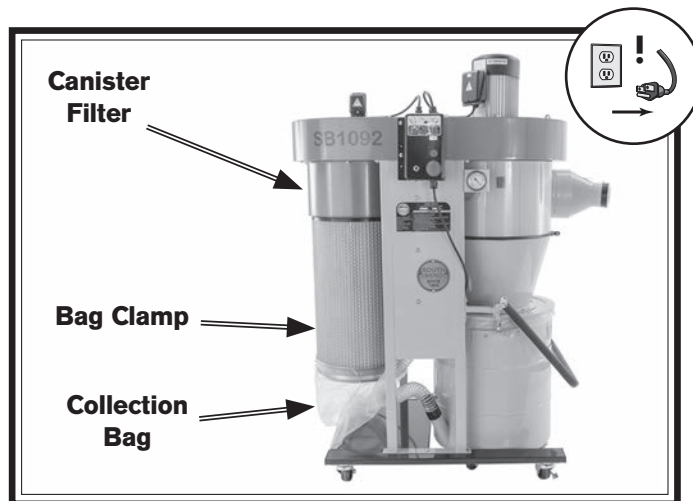
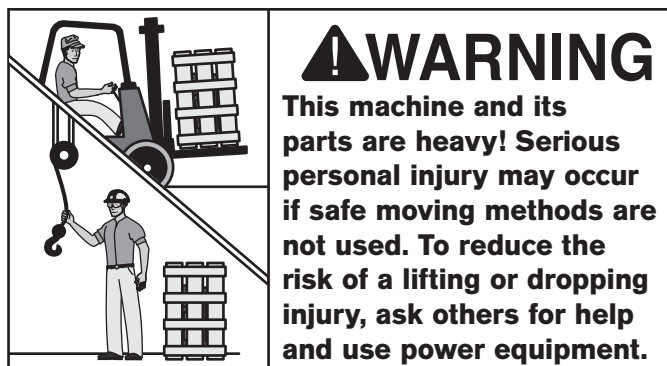

Figure 61. Filter collection bag components.



3. While supporting canister with forklift or jack, remove (8) flange bolts securing canister to housing assembly (see **Figure 62**).



Figure 62. Flange bolts securing canister to housing.

4. Vacuum loose dust inside impeller housing and on machine.
5. Support canister filter with forklift or jack and position it under housing assembly. Rotate filter so that mounting holes align, then rotate spindle so spindle cap is aligned with motor shaft.
6. Attach filter to assembly housing with (8) flange bolts (see **Figure 62**).
7. Attach new filter collection bag around bottom of canister filter and secure with clamp.

Pairing Remote Control to Receiver

The included remote control runs on 2 AAA batteries and has a range of approximately 50 feet. The receiver and remote control must be paired when the batteries are changed, or if the remote control begins to function erratically.

To pair remote:

1. Press and hold red RESET button for 3 seconds (see **Figure 63**) to clear receiver. Receiver will beep three times.

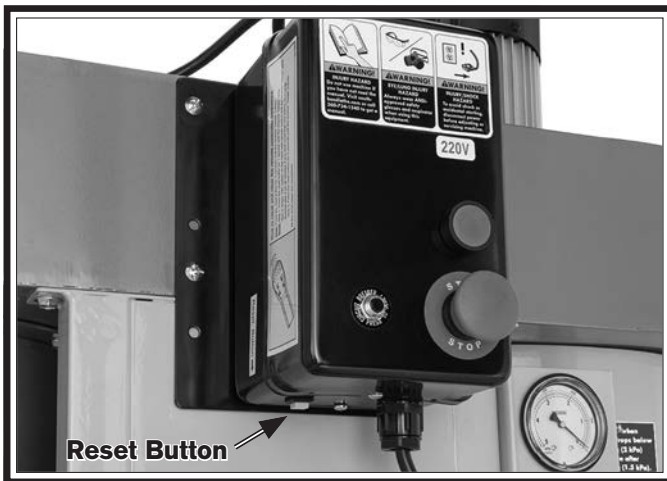

Figure 63. Receiver reset button.

2. Press and hold red RESET button for 1 second. Receiver will beep once when it is ready to pair with remote control.

3. Press and hold remote ON button for 2 seconds (see **Figure 64**). Receiver will beep twice when paired.

Note: Repeat step 3 for each controller you wish to pair to receiver.



Figure 64. Remote control.

4. Press and hold red RESET button for 3 seconds. Receiver will beep three times, indicating pairing is complete.

If you need replacement parts, or if you are unsure how to do any of the solutions given here, feel free to call us at (360) 734-1540.

Symptom	Possible Cause	Possible Solution
Machine does not start or a breaker trips immediately after startup.	<ol style="list-style-type: none"> Dust collector not properly connected to ducting. Machine circuit breaker has tripped (SB1092). Blown fuse. Incorrect power supply voltage or circuit size. Remote control not working. Remote receiver at fault. Thermal overload relay has tripped/ at fault (SB1094). Power supply circuit breaker tripped or fuse blown. Motor wires connected incorrectly. Start capacitor at fault. Wiring broken, disconnected, or corroded. Power switch/circuit breaker at fault. Centrifugal switch adjustment/ contact points at fault. Motor or motor bearings at fault. 	<ol style="list-style-type: none"> Connect dust collector to ducting (Page 24). Reset circuit breaker on switch. Replace fuse/ensure no shorts (Page 43 & 45). Ensure correct power supply voltage and circuit size. Replace battery; stay in signal range (Page 39). Replace. Reset. Adjust or replace if at fault. Ensure circuit is free of shorts. Reset circuit breaker or replace fuse. Correct motor wiring connections. Test/replace if at fault. Fix broken wires or disconnected/corroded connections. Test/replace. Adjust centrifugal switch/clean contact points. Replace either if at fault. Replace motor.
Machine stalls or is underpowered.	<ol style="list-style-type: none"> Dust collection ducting problem. Collection bags full. Canister filter clogged/at fault. Run capacitor at fault. Circuit board at fault. Dust collector too far from machine or undersized for dust-collection system. Motor overheated, tripping machine circuit breaker. Motor or motor bearings at fault. Centrifugal switch adjustment/ contact points at fault. 	<ol style="list-style-type: none"> Allow motor to cool, reset overload if necessary. Replace collection bags. Clean canister filter (Page 36); replace canister filter after 1 year of regular use (Page 38). Test/repair/replace. Replace if at fault. Move closer to machine/redesign ducting layout (Page 24)/upgrade dust collector. Clean motor/let cool, and reduce workload. Reset breaker. Test/repair/replace. Adjust centrifugal switch/clean contact points. Replace either if at fault.
Machine has excessive vibration or noise.	<ol style="list-style-type: none"> Motor or component loose. Motor mount loose/broken. Motor fan rubbing on fan cover. Centrifugal switch is at fault. Impeller damaged, unbalanced, or loose. Motor bearings at fault. 	<ol style="list-style-type: none"> Inspect/replace damaged or missing bolts/nuts, and retighten with thread-locking fluid. Tighten/replace. Fix/replace fan cover; replace loose/damaged fan. Adjust/replace centrifugal switch if available. Inspect/tighten/replace. Test by rotating shaft; rotational grinding/loose shaft requires bearing replacement.

Symptom	Possible Cause	Possible Solution
Loud, repetitious noise, or excessive vibration coming from dust collector (non-motor related).	<ol style="list-style-type: none"> 1. Dust collector not on a flat surface and wobbles/casters not locked. 2. Impeller damaged and unbalanced. 3. Impeller loose on the motor shaft. 	<ol style="list-style-type: none"> 1. Stabilize dust collector; lock casters. 2. Disconnect dust collector from power; inspect impeller for dents, bends, or loose fins; replace impeller if damaged. 3. Secure impeller; replace motor and impeller as a set if motor shaft and impeller hub are damaged.
Dust collector does not adequately collect dust or chips; poor performance.	<ol style="list-style-type: none"> 1. Collection bag full. 2. Canister filter clogged/at fault. 3. Ducting blocked/restricted. 4. Dust collector too far away from point of suction; duct clamps not properly secured; too many sharp bends in ducting. 5. Lumber is wet and dust is not flowing smoothly through ducting. 6. Ducting has one or more leaks, or too many open ports. 7. Not enough open branch lines at one time, causing velocity drop in main line. 8. Ducting and ports are incorrectly sized. 9. Machine dust-collection design inadequate. 10. Dust collector undersized. 11. Filter brush motor at fault. 	<ol style="list-style-type: none"> 1. Empty collection bag (Page 37). 2. Clean canister filter (Page 36); replace canister filter (Page 38). 3. Remove ducting from dust collector inlet and unblock restriction. A plumbing snake may be necessary. 4. Relocate dust collector closer to point of suction; re-secure ducts; remove sharp bends (Page 24). 5. Only process lumber with less than 20% moisture content. 6. Seal/eliminate all ducting leaks; close dust ports for lines not being used (Page 23). 7. Open 1 or 2 more blast gates to different branch lines to increase main line velocity. 8. Install correctly sized ducts and fittings (Page 24). 9. Use dust-collection hood on stand. 10. Install larger dust collector. 11. Test/repair/replace.
Dust collector blows sawdust into the air.	<ol style="list-style-type: none"> 1. Duct clamps or filter collection bag not properly clamped and secured; ducting loose/damaged. 2. Cylinder or funnel seals are loose or damaged. 	<ol style="list-style-type: none"> 1. Secure ducts and filter collection bag, making sure duct and bag clamp are tight; tighten/replace ducting. 2. Tighten all mounting and sealing points; replace damaged seals/gaskets.
Remote control does not operate dust collector.	<ol style="list-style-type: none"> 1. Machine is disconnected from power. 2. Remote control battery is weak or dead. 3. A wall or barrier disrupts the radio frequency, or controller is too far away. 4. Remote control not paired with receiver. 	<ol style="list-style-type: none"> 1. Verify machine is connected to power source. 2. Replace battery. 3. Move machine away from barrier; use remote within 50' of machine. 4. Program receiver to accept remote control (Page 39).

Electrical Safety Instructions

These pages are accurate at the time of printing. In the constant effort to improve, however, we may make changes to the electrical systems of future machines. Study this section carefully. If you see differences between your machine and what is shown in this section, call Technical Support at (360) 734-1540 for assistance BEFORE making any changes to the wiring on your machine.

Shock Hazard: It is extremely dangerous to perform electrical or wiring tasks while the machine is connected to the power source. Touching electrified parts will result in personal injury including but not limited to severe burns, electrocution, or death. For your own safety, disconnect machine from the power source before servicing electrical components or performing any wiring tasks!

Wire Connections: All connections must be tight to prevent wires from loosening during machine operation. Double-check all wires disconnected or connected during any wiring task to ensure tight connections.

Modifications: Using aftermarket parts or modifying the wiring beyond what is shown in the diagram may lead to unpredictable results, including serious injury or fire.

Motor Wiring: The motor wiring shown in these diagrams is current at the time of printing, but it may not match your machine. Always use the wiring diagram inside the motor junction box.

Circuit Requirements: Connecting the machine to an improperly sized circuit will greatly increase the risk of fire. To minimize this risk, only connect the machine to a power circuit that meets the minimum requirements given in this manual.

Capacitors/Inverters: Some capacitors and power inverters store an electrical charge for up to 10 minutes after being disconnected from the power source. To reduce the risk of being shocked, wait at least this long before working on capacitors.

Wire/Component Damage: Damaged wires or components increase the risk of serious personal injury, fire, or machine damage. If you notice that any wires or components are damaged while performing a wiring task, replace those wires or components before completing the task.

Experiencing Difficulties: If you are experiencing difficulties understanding the information included in this section, contact our Technical Support at (360) 734-1540.

WIRING DIAGRAM COLOR KEY

BLACK — Bk	BLUE WHITE — Bw	RED — Rd	PINK — Pk	WHITE — Wt
BLUE — Bl	GREEN — Gn	LIGHT BLUE — Lb	PURPLE — Pu	YELLOW GREEN — Yg
BROWN — Br	GRAY — Gy	ORANGE — Or	TUR-QUIOSE — Tu	YELLOW — Yl

NOTICE: The photos and diagrams included in this section are best viewed in color. You can see them in color at www.southbendtools.com.

SB1092 Wiring Diagram

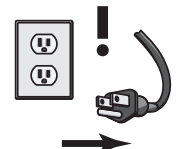

! WARNING!

SHOCK HAZARD!

Disconnect power before working on wiring.

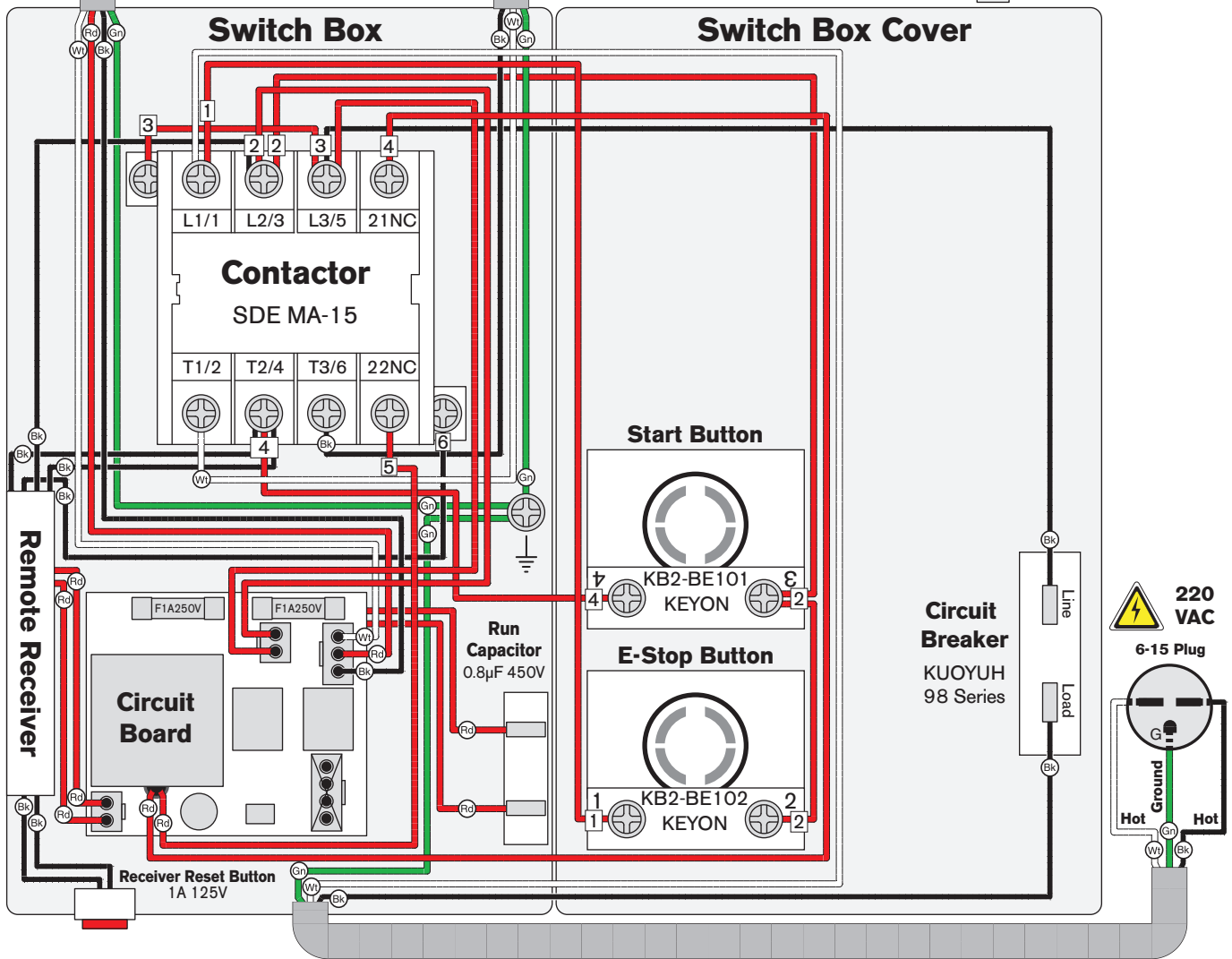
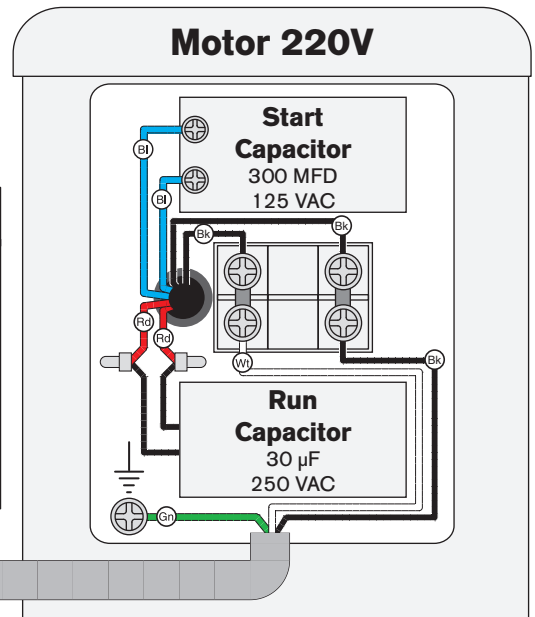
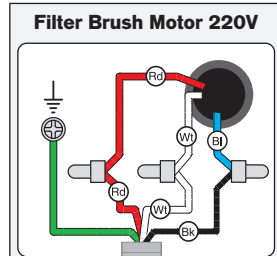

SB1092 Electrical Component Pictures

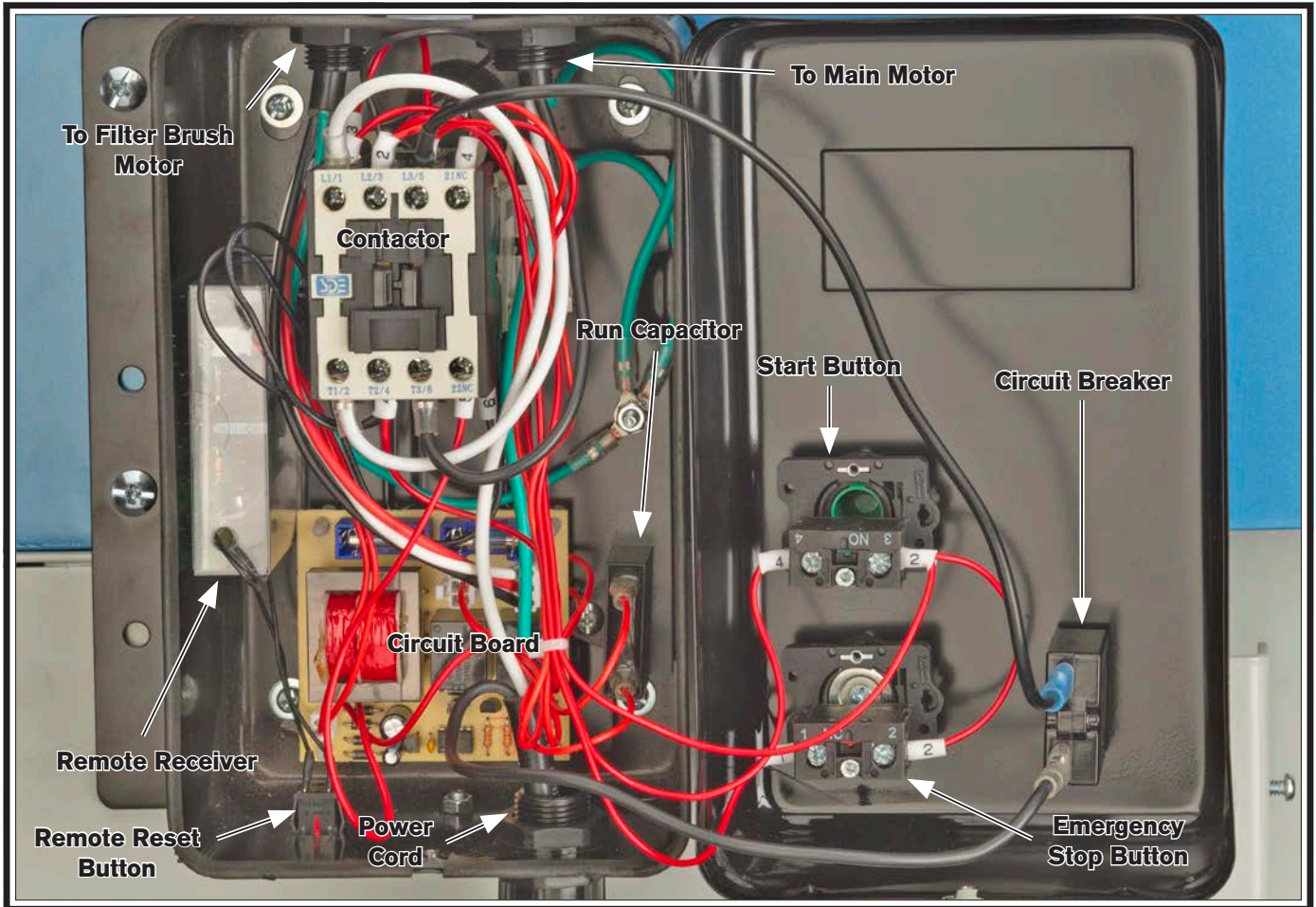

Figure 65. SB1092 switch box interior.

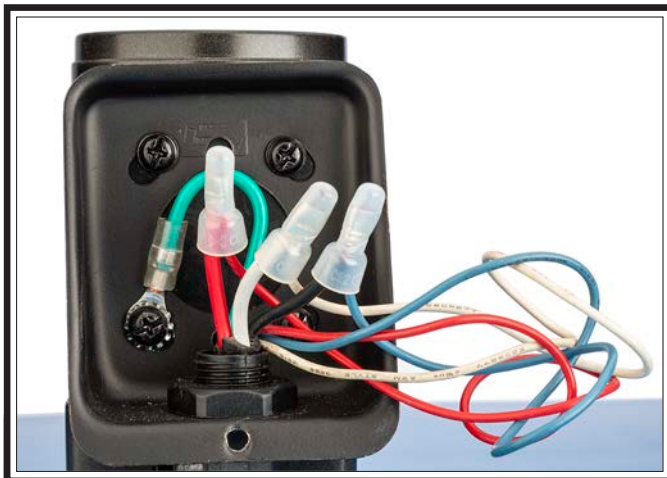
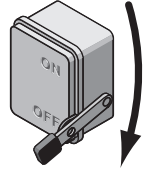

Figure 66. SB1092 filter brush motor junction box.

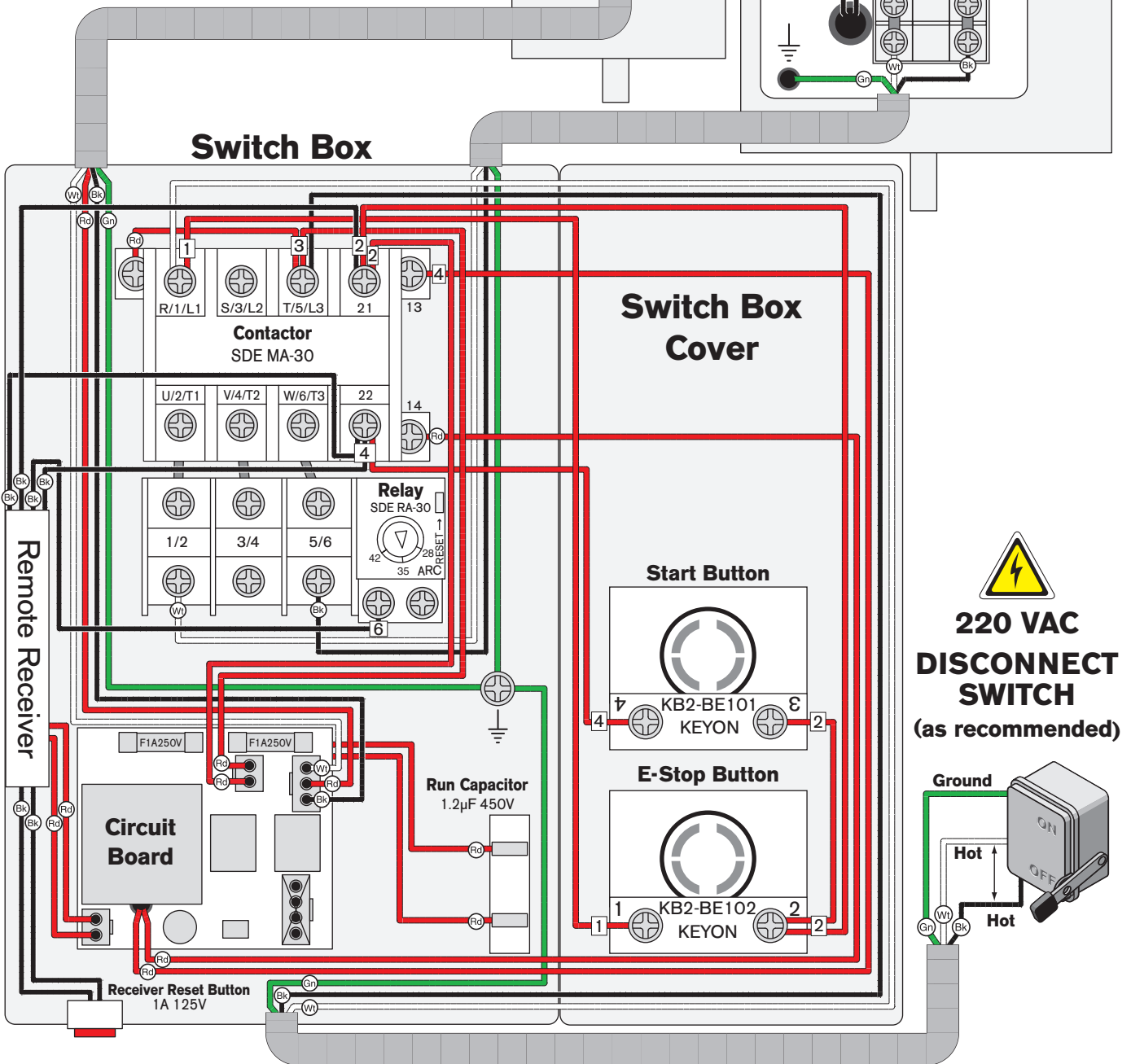
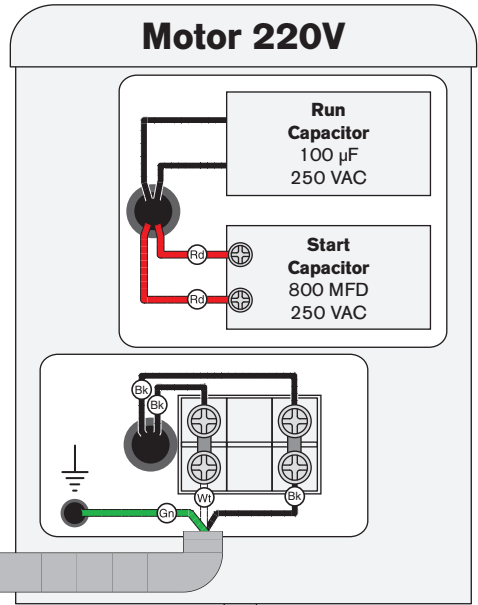
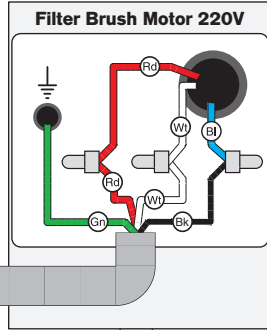



Figure 67. SB1092 main motor junction box.

SB1094 Wiring Diagram



⚠ WARNING!
DISCONNECT
POWER BEFORE
ADJUSTMENTS,
MAINTENANCE,
OR SERVICE.

**220 VAC
DISCONNECT
SWITCH
(as recommended)**

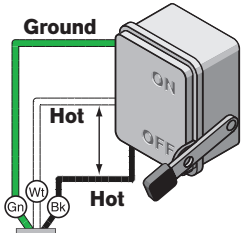

Ground
Hot
Hot

SB1094 Electrical Component Pictures

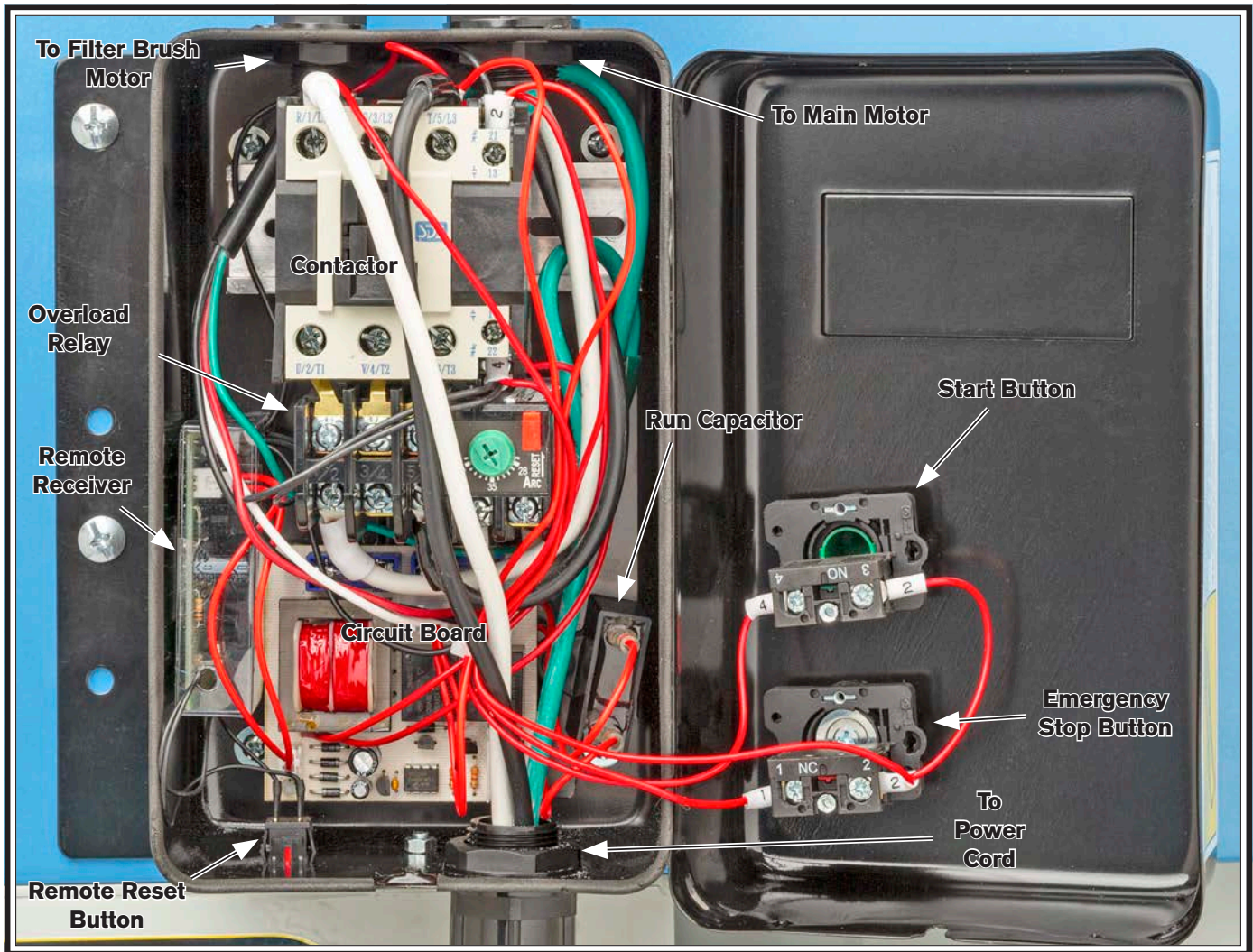

Figure 68. SB1094 switch box interior.

SB1094 Electrical Component Pictures



Figure 69. SB1094 filter brush motor junction box.

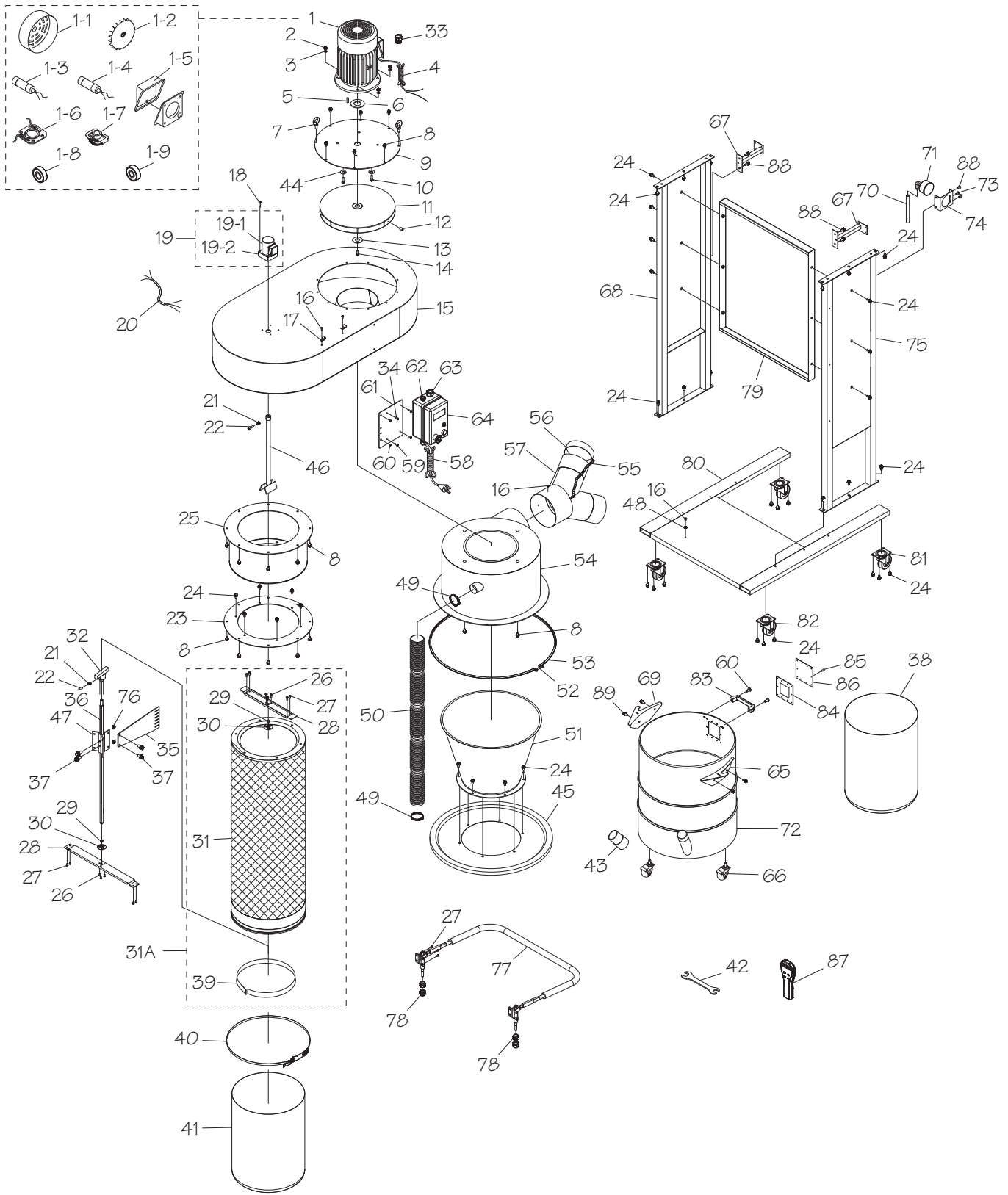

Figure 71. SB1094 main motor junction box.



Figure 70. SB1094 capacitor box.

SB1092 Parts



SB1092 Parts List

REF	PART #	DESCRIPTION
1	PSB1092001	MOTOR 2HP 220V 1-PH
1-1	PSB1092001-1	MOTOR FAN COVER
1-2	PSB1092001-2	MOTOR FAN
1-3	PSB1092001-3	S CAPACITOR 300M 125V
1-4	PSB1092001-4	R CAPACITOR 30M 250V
1-5	PSB1092001-5	JUNCTION BOX
1-6	PSB1092001-6	CONTACT PLATE
1-7	PSB1092001-7	CENTRIFUGAL SWITCH
1-8	PSB1092001-8	FRONT MOTOR BEARING 6205RZ
1-9	PSB1092001-9	REAR MOTOR BEARING 6203RZ
2	PSB1092002	HEX NUT 5/16-18
3	PSB1092003	LOCK WASHER 5/16
4	PSB1092004	MOTOR CORD 12G 3W 18"
5	PSB1092005	KEY 7 X 7 X 30
6	PSB1092006	RUBBER GASKET
7	PSB1092007	EYE BOLT 3/4", 5/16-18 X 5/8
8	PSB1092008	FLANGE BOLT 5/16-18 X 3/4
9	PSB1092009	MOTOR PLATE
10	PSB1092010	HEX BOLT 5/16-18 X 1
11	PSB1092011	IMPELLER 14.5" ALUMINUM
12	PSB1092012	SET SCREW 3/8-16 X 3/4
13	PSB1092013	IMPELLER WASHER
14	PSB1092014	CAP SCREW M6-1 X 25
15	PSB1092015	MAIN HOUSING
16	PSB1092016	TAP SCREW #10 X 3/8
17	PSB1092017	WIRE CLIP UC4
18	PSB1092018	CAP SCREW M4-.7 X 60
19	PSB1092019	FILTER BRUSH MOTOR ASSEMBLY
19-1	PSB1092019-1	MOTOR 6W 220V 1-PH
19-2	PSB1092019-2	GEAR REDUCER LUYANG 2GN90(B1)
20	PSB1092020	MOTOR CORD 14G 4W 22"
21	PSB1092021	HEX NUT M5-.8
22	PSB1092022	SET SCREW M5-.8 X 12
23	PSB1092023	CANISTER MOUNTING PLATE
24	PSB1092024	FLANGE BOLT 5/16-18 X 1/2
25	PSB1092025	MUFFLER
26	PSB1092026	PHLP HD SCR M5-.8 X 6
27	PSB1092027	PHLP HD SCR M5-.8 X 8
28	PSB1092028	SELF-ALIGNING SPINDLE MOUNTING PLATE
29	PSB1092029	BALL BEARING 1206
30	PSB1092030	BEARING RETAINER
31A	PSB1092031A	CANISTER FILTER ASSEMBLY
31	PSB1092031	CANISTER FILTER
32	PSB1092032	FILTER BRUSH SPINDLE CAP
33	PSB1092033	STRAIN RELIEF TYPE-3 M16-2
34	PSB1092034	PHLP HD SCR 10-24 X 1/4
35	PSB1092035	SCRAPER
36	PSB1092036	FILTER BRUSH SPINDLE
37	PSB1092037	FLANGE BOLT M5-.8 X 12
38	PSB1092038	DRUM COLLECTION BAG (PLASTIC)
39	PSB1092039	FOAM TAPE 3/4"

REF	PART #	DESCRIPTION
40	PSB1092040	BAG CLAMP
41	PSB1092041	FILTER COLLECTION BAG (PLASTIC)
42	PSB1092042	WRENCH 10 X 12MM OPEN-ENDS
43	PSB1092043	QUICK CONNECTOR
44	PSB1092044	FENDER WASHER 3/8
45	PSB1092045	DRUM LID
46	PSB1092046	FILTER BRUSH MOTOR SHAFT
47	PSB1092047	SCRAPER MOUNT
48	PSB1092048	EXT TOOTH WASHER 4MM
49	PSB1092049	HOSE CLAMP 2"
50	PSB1092050	FLEXIBLE HOSE 2"
51	PSB1092051	CYCLONE FUNNEL
52	PSB1092052	HEX BOLT 1/4-20 X 2-1/2
53	PSB1092053	CONE CLAMP
54	PSB1092054	INTAKE HOUSING
55	PSB1092055	CHAIN
56	PSB1092056	INLET CAP 4"
57	PSB1092057	INLET ADAPTER 8" X 4" X 2
58	PSB1092058	POWER CORD 14G 3W 130" 6-15P
59	PSB1092059	PHLP HD SCR 10-24 X 1/4
60	PSB1092060	FLAT HD SCR 1/4-20 X 1/2
61	PSB1092061	SWITCH BOX MOUNTING PLATE
62	PSB1092062	STRAIN RELIEF TYPE-3 M16-2
63	PSB1092063	STRAIN RELIEF TYPE-3 M20-2.5
64	PSB1092064	MAGNETIC SWITCH
65	PSB1092065	LEFT DRUM BRACKET
66	PSB1092066	DRUM CASTER 2"
67	PSB1092067	HANDLE BRACKET
68	PSB1092068	RIGHT SIDE PANEL
69	PSB1092069	RIGHT DRUM BRACKET
70	PSB1092070	CLEAR TUBE 6 X 175MM
71	PSB1092071	VACUUM PRESSURE GAUGE
72	PSB1092072	COLLECTION DRUM
73	PSB1092073	PHLP HD SCR 10-24 X 1/2
74	PSB1092074	VACUUM GAUGE MOUNT
75	PSB1092075	LEFT SIDE PANEL
76	PSB1092076	FLANGE NUT M5-.8
77	PSB1092077	DRUM LOCK HANDLE
78	PSB1092078	LOCK NUT M10-1.5
79	PSB1092079	SUPPORT PANEL
80	PSB1092080	BASE
81	PSB1092081	CASTER 3"
82	PSB1092082	LOCKING CASTER 3"
83	PSB1092083	DRUM HANDLE
84	PSB1092084	WINDOW SEAL
85	PSB1092085	RIVET 9 X 3 BLIND
86	PSB1092086	DRUM WINDOW
87	PSB1092087	REMOTE CONTROL
88	PSB1092088	FLANGE BOLT 1/4-20 X 1/2
89	PSB1092089	FLANGE BOLT 5/16-18 X 3/8

SB1094 Parts

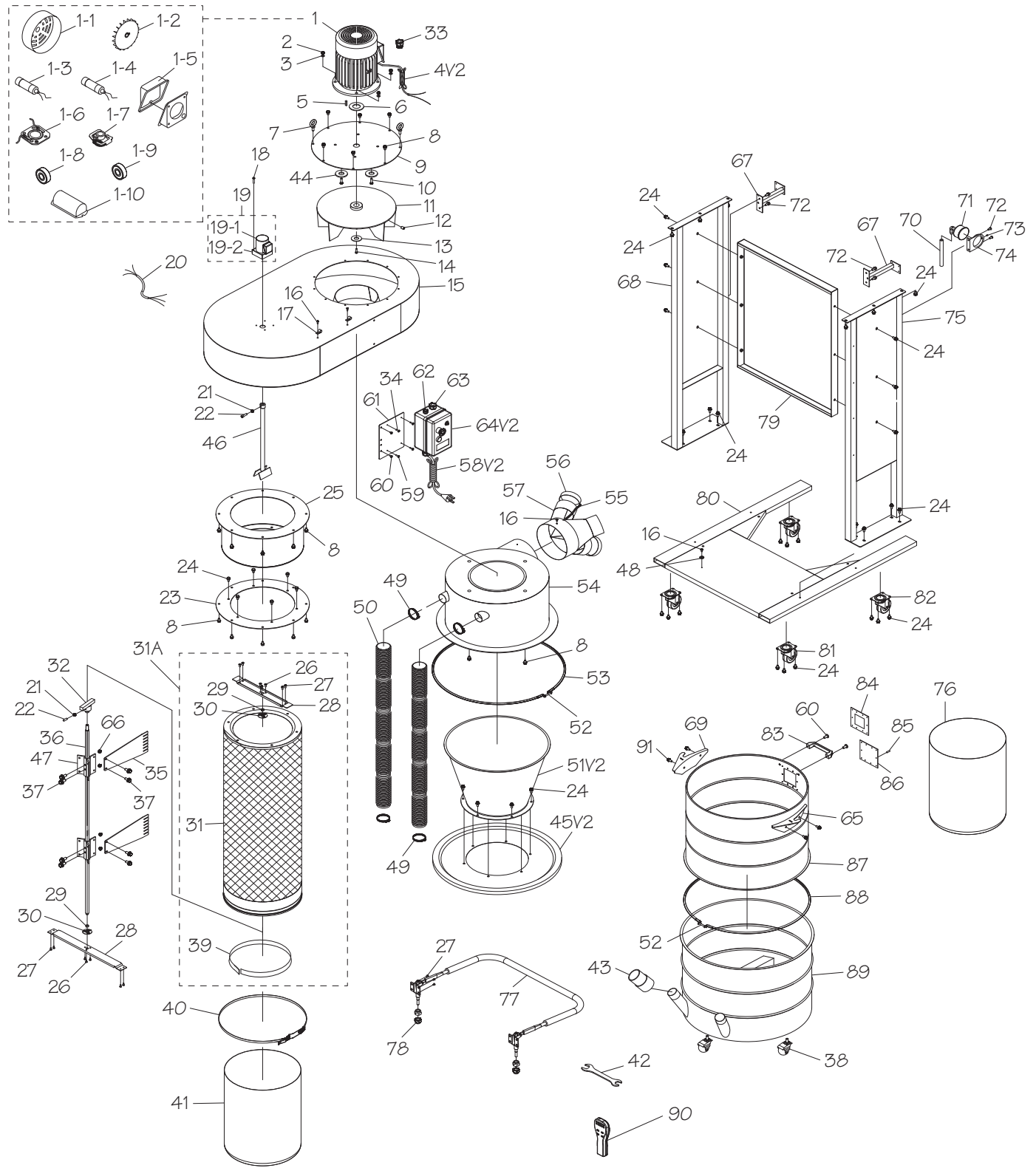

SB1094 Parts List

REF	PART #	DESCRIPTION
1	PSB1094001	MOTOR 5HP 220V 1-PH
1-1	PSB1094001-1	MOTOR FAN COVER
1-2	PSB1094001-2	MOTOR FAN
1-3	PSB1094001-3	S CAPACITOR 800M 250V
1-4	PSB1094001-4	R CAPACITOR 100M 250V
1-5	PSB1094001-5	JUNCTION BOX
1-6	PSB1094001-6	CONTACT PLATE
1-7	PSB1094001-7	CENTRIFUGAL SWITCH
1-8	PSB1094001-8	FRONT MOTOR BEARING 6306Z
1-9	PSB1094001-9	REAR MOTOR BEARING 6305Z
1-10	PSB1094001-10	CAPACITOR COVER
2	PSB1094002	HEX NUT 3/8-16
3	PSB1094003	LOCK WASHER 3/8
4V2	PSB1094004V2	MOTOR CORD 8G 3W 38" V2.08.23
5	PSB1094005	KEY 8 X 8 X 25
6	PSB1094006	RUBBER GASKET
7	PSB1094007	EYE BOLT 3/4", 5/16-18 X 5/8
8	PSB1094008	FLANGE BOLT 5/16-18 X 3/4
9	PSB1094009	MOTOR PLATE
10	PSB1094010	HEX BOLT 3/8-16 X 1-1/2
11	PSB1094011	IMPELLER 15.6" ALUMINUM
12	PSB1094012	SET SCREW 3/8-16 X 3/4
13	PSB1094013	IMPELLER WASHER
14	PSB1094014	CAP SCREW M6-1 X 25
15	PSB1094015	MAIN HOUSING
16	PSB1094016	TAP SCREW #10 X 3/8
17	PSB1094017	WIRE CLIP UC4
18	PSB1094018	CAP SCREW M4-.7 X 60
19	PSB1094019	FILTER BRUSH MOTOR ASSEMBLY
19-1	PSB1094019-1	MOTOR 15W 220V 1-PH
19-2	PSB1094019-2	GEAR REDUCER LUYANG 3GN90(B1)
20	PSB1094020	MOTOR CORD 20G 4W 43"
21	PSB1094021	HEX NUT M5-.8
22	PSB1094022	SET SCREW M5-.8 X 12
23	PSB1094023	CANISTER MOUNTING PLATE
24	PSB1094024	FLANGE BOLT 5/16-18 X 1/2
25	PSB1094025	MUFFLER
26	PSB1094026	PHLP HD SCR M5-.8 X 6
27	PSB1094027	PHLP HD SCR M5-.8 X 8
28	PSB1094028	SELF-ALIGNING SPINDLE MOUNTING PLATE
29	PSB1094029	BALL BEARING 1206
30	PSB1094030	BEARING RETAINER
31A	PSB1094031A	CANISTER FILTER ASSEMBLY
31	PSB1094031	CANISTER FILTER
32	PSB1094032	FILTER BRUSH SPINDLE CAP
33	PSB1094033	STRAIN RELIEF TYPE-3 M16-2
34	PSB1094034	PHLP HD SCR 10-24 X 1/4
35	PSB1094035	SCRAPER
36	PSB1094036	FILTER BRUSH SPINDLE
37	PSB1094037	FLANGE BOLT M5-.8 X 12
38	PSB1094038	DRUM CASTER 2"
39	PSB1094039	FOAM TAPE 3/4"

REF	PART #	DESCRIPTION
40	PSB1094040	BAG CLAMP
41	PSB1094041	FILTER COLLECTION BAG (PLASTIC)
42	PSB1094042	WRENCH 10 X 12MM OPEN-ENDS
43	PSB1094043	QUICK CONNECTOR
44	PSB1094044	FENDER WASHER 3/8
45V2	PSB1094045V2	DRUM LID V2.12.21
46	PSB1094046	FILTER BRUSH MOTOR SHAFT
47	PSB1094047	SCRAPER MOUNT
48	PSB1094048	EXT TOOTH WASHER 5MM
49	PSB1094049	HOSE CLAMP 2"
50	PSB1094050	FLEXIBLE HOSE 2"
51V2	PSB1094051V2	CYCLONE FUNNEL V2.12.21
52	PSB1094052	HEX BOLT 1/4-20 X 2-1/2
53	PSB1094053	CONE CLAMP
54	PSB1094054	INTAKE HOUSING
55	PSB1094055	CHAIN
56	PSB1094056	INLET CAP 4"
57	PSB1094057	INLET ADAPTER 10" X 4" X 4
58V2	PSB1094058V2	POWER CORD 8G 3W 125" V2.08.23
59	PSB1094059	PHLP HD SCR 10-24 X 1/4
60	PSB1094060	FLAT HD SCR 1/4-20 X 1/2
61	PSB1094061	SWITCH BOX MOUNTING PLATE
62	PSB1094062	STRAIN RELIEF TYPE-3 M16-2
63	PSB1094063	STRAIN RELIEF TYPE-3 M25-3
64V2	PSB1094064V2	MAGNETIC SWITCH V2.08.23
65	PSB1094065	LEFT DRUM BRACKET
66	PSB1094066	FLANGE NUT M5-.8
67	PSB1094067	HANDLE BRACKET
68	PSB1094068	RIGHT SIDE PANEL
69	PSB1094069	RIGHT DRUM BRACKET
70	PSB1094070	CLEAR TUBE 6 X 360MM
71	PSB1094071	VACUUM PRESSURE GAUGE
72	PSB1094072	FLANGE BOLT 1/4-20 X 1/2
73	PSB1094073	PHLP HD SCR 10-24 X 1/2
74	PSB1094074	VACUUM GAUGE MOUNT
75	PSB1094075	LEFT SIDE PANEL
76	PSB1094076	DRUM COLLECTION BAG (PLASTIC)
77	PSB1094077	DRUM LOCK HANDLE
78	PSB1094078	LOCK NUT M10-1.5
79	PSB1094079	SUPPORT PANEL
80	PSB1094080	BASE
81	PSB1094081	LOCKING CASTER 3"
82	PSB1094082	CASTER 3"
83	PSB1094083	DRUM HANDLE
84	PSB1094084	WINDOW SEAL
85	PSB1094085	RIVET 9 X 3 BLIND
86	PSB1094086	DRUM WINDOW
87	PSB1094087	UPPER COLLECTION DRUM
88	PSB1094088	DRUM CLAMP
89	PSB1094089	LOWER COLLECTION DRUM
90	PSB1094090	REMOTE CONTROL
91	PSB1094091	FLANGE BOLT 5/16-18 X 3/8

Machine Labels



MODEL SB1094
5 HP CYCLONE DUST COLLECTOR

WARNING!

To reduce the risk of serious injury when using this machine:

1. Read and understand owner's manual before operating.
2. Always wear approved eye protection and respirator.
3. Properly ground machine—connect to permanently grounded metal wiring system or an equipment-grounding conductor.
4. Only use this machine to collect wood dust/chips—never use to collect glass, metal, liquids, asbestos, silica, animal parts, biohazards, burning material, ashes, etc.
5. Do not expose to rain or use in wet areas.
6. Always disconnect power before servicing or cleaning.
7. Never handle, long hair, and loose clothing away from belt.
8. Never leave machine unattended during operation.
9. Do not use if power supply wires, controls, or any other electrical equipment becomes damaged—promptly repair!
10. Do not use without dust bag, container, or filter in place.
11. Always wear a respirator when emptying bags or canisters.
12. Do not modify machine in any way.
13. Prevent unauthorized use by children or untrained users; restrict access to disable machine when unattended.

Main Motor: 5 HP, 230V, 1.7A, 60 Hz
 Full Load Current Rating: 24A
 Airflow Performance: 2399 CFM @ 2.11" H₂O
 Max. Static Pressure: 1.4" H₂O
 Main Inlet Size: 10"
 Adapter Inlet Size: 4"
 Max. Collection Capacity: 60 Gallons
 Cartridge Filter: 18.5" x 9.5" x 1"
 Filter Rating: 1 Micron
 Replacement Filter: SB 129
 Replacement Filter Bag: T3700
 Replacement Dust Bag: SB 106
 Weight: 487 lbs.

Made in Taiwan to South Bend Specifications

REF	PART #	DESCRIPTION
101	PSB1092101	DUST COLLECTOR COMBO LABEL (SB1092)
101	PSB1094101	DUST COLLECTOR COMBO LABEL (SB1094)
102	PSB1092102	ELECTRICITY LABEL 1.4W X 1.2H
103	PSB1092103	VACUUM PRESSURE GAUGE LABEL
104	PSB1092104	SOUTH BEND REMOTE LABEL
105	PSB1092105	SOUTH BEND NAMEPLATE 90MM (SB1092)

REF	PART #	DESCRIPTION
105	PSB1094105	SOUTH BEND NAMEPLATE 125MM (SB1094)
106	PSB1092106	MACHINE ID LABEL (SB1092)
106	PSB1094106	MACHINE ID LABEL (SB1094)
107	PSB1092107	MODEL NUMBER LABEL (SB1092)
107	PSB1094107	MODEL NUMBER LABEL (SB1094)

⚠ WARNING

The safety labels provided with your machine are used to make the operator aware of the machine hazards and ways to prevent injury. The owner of this machine **MUST** maintain the original location and readability of these safety labels. If any label is removed or becomes unreadable, **REPLACE** that label before using the machine again. Contact South Bend Tools at (360) 734-1540 or www.southbendtools.com to order new labels.

Warranty

This quality product is warranted by South Bend Tools to the original buyer for **2 years** from the date of purchase. This warranty does not apply to consumable parts, or defects due to any kind of misuse, abuse, negligence, accidents, repairs, alterations or lack of maintenance. We do not reimburse for third party repairs. In no event shall we be liable for death, injuries to persons or property, or for incidental, contingent, special or consequential damages arising from the use of our products.

We do not warrant or represent that this machine complies with the provisions of any law, act, code, regulation, or standard of any domestic or foreign government, industry, or authority. In no event shall South Bend's liability under this warranty exceed the original purchase price paid for this machine. Any legal actions brought against South Bend Tools shall be tried in the State of Washington, County of Whatcom.

This is the sole written warranty for this machine. Any and all warranties that may be implied by law, including any merchantability or fitness, for any purpose, are hereby limited to the duration of this warranty.

Thank you for your business and continued support.

To take advantage of this warranty, register at <https://www.grizzly.com/forms/warranty>, or you can scan the QR code below to be automatically directed to our warranty registration page. Enter all applicable information for the product.





southbendtools.com

