



# Model SB1090 37" x 53" Downdraft Table INSTRUCTION SHEET

P.O. Box 2027, Bellingham, WA 98227 U.S.A.  
PHONE: (360) 734-1540 • www.southbendlathe.com



The Model SB1090 37" x 53" Downdraft Table features heavy-duty steel-frame construction, removable table boards, an internal V-bottom for directing air flow, and two 4" dust ports.

Both table shoulders sit 1½" below the center work table for efficient edge-sanding. Table height can be adjusted from 26" to 43" tall.



**Figure 1. SB1090 37" x 53" Downdraft Table.**

## Specifications

Table Size .....	37" x 53"
Shoulder Table Size .....	6" x 53"
Table Height Range .....	26"–43"
Dust Port Size .....	4"
Load Capacity (Per Suction Board).....	40.5 lbs.
Weight.....	140 lbs.

## Inventory

Main Inventory (Figure 2)	Qty
A. Table .....	1
B. Suction Boards .....	7
C. Shoulder Suction Boards .....	2
D. Foot Pads .....	4
E. Lower Support Legs .....	4
F. Upper Support Legs .....	4

Not Shown	Qty
• Flange Bolts 5/16"-18 x 1/2" .....	32
• Hex Nuts 1/2"-13 .....	4
• Work Stop Nuts.....	8
• Work Stops .....	8
• Grommets .....	264

### ⚠ WARNING

	<p><b>Incorrect use of this tool can result in death or serious injury. For your own safety, read and understand this entire document before using.</b></p>
	<p><b>To reduce risk of eye injury or lung damage from dust, always wear safety glasses and a respirator when operating downdraft table!</b></p>

**INJURY HAZARD!**

- Ensure table is properly set up and connected to a dust collection system before using.
- Only use table to collect wood dust.

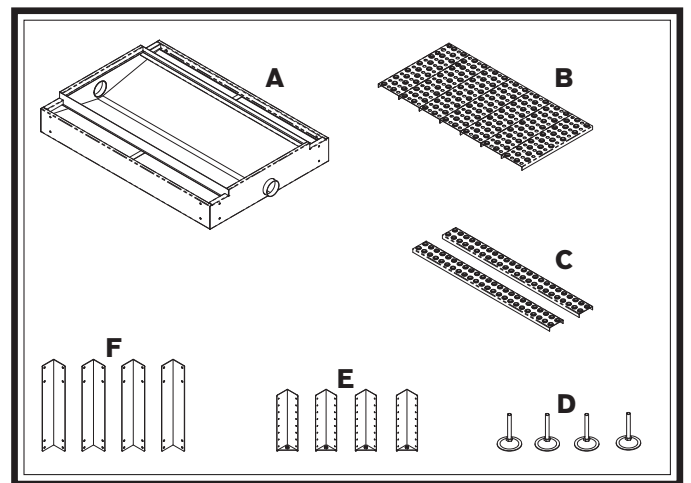

**Figure 2. Model SB1090 Inventory.**

# Needed for Setup

Description	Qty
• Additional Person for Lifting.....	1
• Safety Glasses (for each person) .....	1
• Adjustable Wrench.....	1
• Dust Collection Hose 4" .....	1
• Hose Clamp 4" .....	1

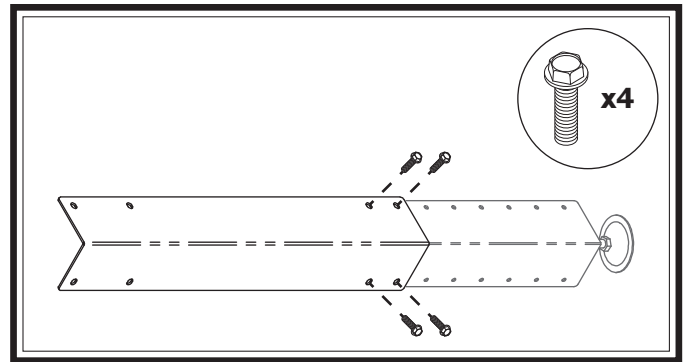

Figure 4. Attaching lower support leg to upper leg.

- Attach each support leg assembly to each corner of table using (4) 5/16"-18 x 1/2" flange bolts (see **Figure 5**).

# Assembly

The procedure that follows describes the general steps required for assembly.

## To assemble the downdraft table:

- Place a piece of cardboard or other protective material on a flat, level, hard floor, then place table face-down on it.
- Attach each foot pad to each lower support leg using (1) 1/2"-13 hex nut (see **Figure 3**).

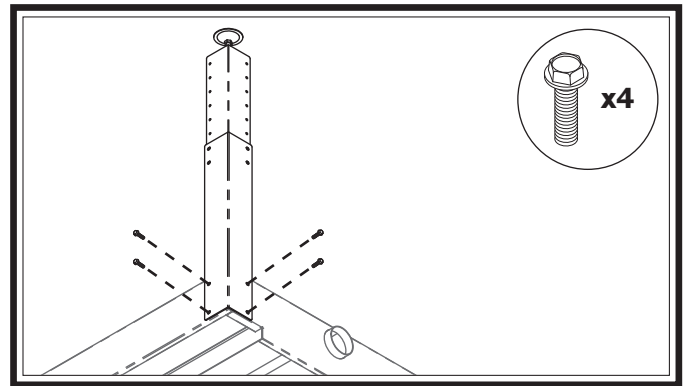

Figure 5. Attaching leg assembly to table.

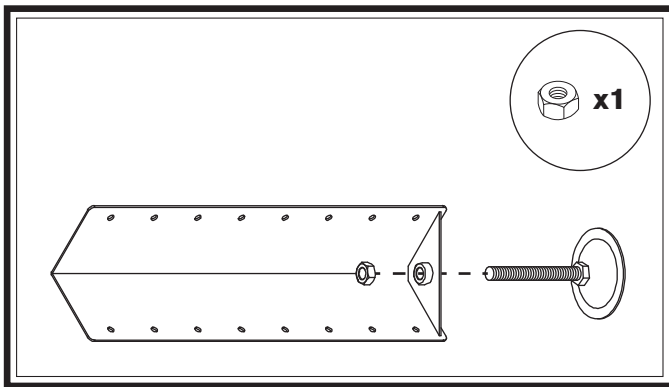

Figure 3. Attaching foot pad to lower support leg.

- Attach each lower support leg to each upper support leg using (4) 5/16"-18 x 1/2" flange bolts (see **Figure 4**).

- Stand table up, and place in desired position.
- Place suction boards in table and press grommets in holes, as desired.
- Connect downdraft table dust port to dust collection system with a 4" dust hose and clamp (see **Figure 6**).

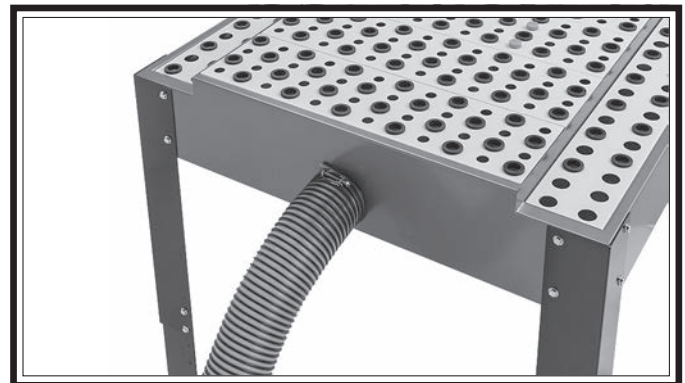
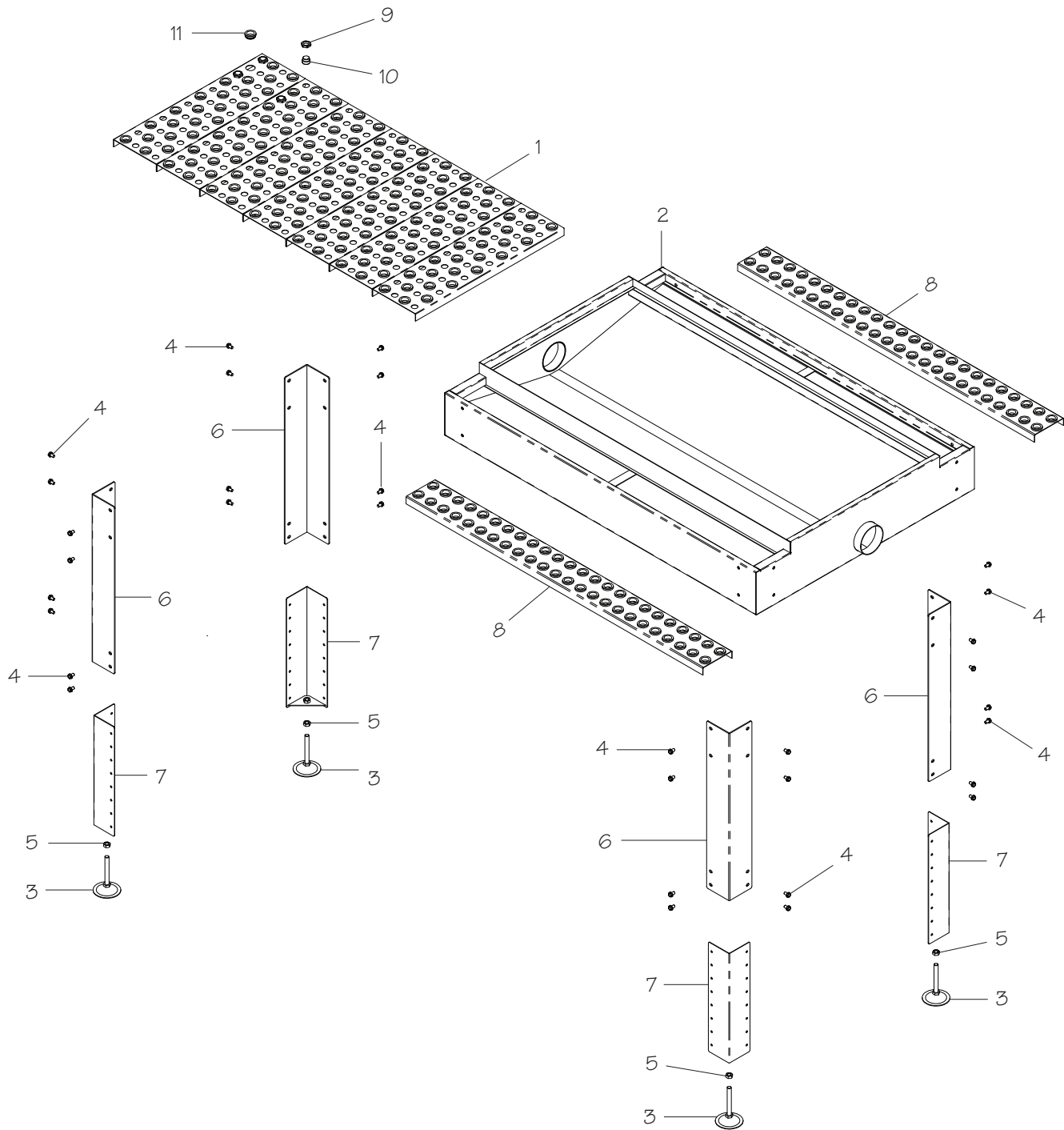

Figure 6. Dust hose connected to dust port.

# Parts Breakdown & List\*



REF PART #	DESCRIPTION
1	PSB1090001 SUCTION BOARD
2	PSB1090002 TABLE
3	PSB1090003 FOOT PAD 1/2-13 X 3-1/8
4	PSB1090004 FLANGE BOLT 5/16-18 X 1/2
5	PSB1090005 HEX NUT 1/2-13
6	PSB1090006 SUPPORT LEG (UPPER)

REF PART #	DESCRIPTION
7	PSB1090007 SUPPORT LEG (LOWER)
8	PSB1090008 SHOULDER SUCTION BOARD
9	PSB1090009 WORK STOP NUT
10	PSB1090010 WORK STOP
11	PSB1090011 GROMMET

\* Breakdown is for illustration purposes. Not all parts may be available for purchase.

# Machine Labels

# SB1090

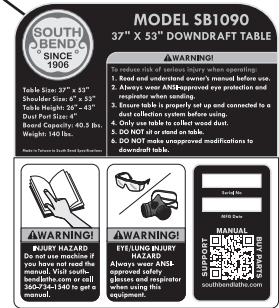

REF PART #	DESCRIPTION
101	PSB1090101 MODEL NUMBER LABEL
102	PSB1090102 SOUTH BEND NAMEPLATE 125MM
103	PSB1090103 MACHINE ID LABEL

REF PART #	DESCRIPTION
104	PSB1090104 TOUCH-UP PAINT, SB LIGHT BLUE
105	PSB1090105 TOUCH-UP PAINT, SB DARK BLUE

## **!WARNING**

The safety labels provided with your machine are used to make the operator aware of the machine hazards and ways to prevent injury. The owner of this machine **MUST** maintain the original location and readability of these safety labels. If any label is removed or becomes unreadable, **REPLACE** that label before using the machine again. Contact South Bend Lathe Co. at (360) 734-1540 or [www.southbendlathe.com](http://www.southbendlathe.com) to order new labels.