



MODEL M1116 MILL-DRILL w/DRO



OWNER'S MANUAL

(FOR MODELS MANUFACTURED SINCE 06/17)

Phone: (360) 734-3482 • Online Technical Support: techsupport@woodstockint.com

COPYRIGHT © FEBRUARY, 2018 BY WOODSTOCK INTERNATIONAL, INC.
WARNING: NO PORTION OF THIS MANUAL MAY BE REPRODUCED IN ANY SHAPE OR FORM WITHOUT
THE WRITTEN APPROVAL OF WOODSTOCK INTERNATIONAL, INC.

#19003KB Printed in China



WARNING!

This manual provides critical safety instructions on the proper setup, operation, maintenance, and service of this machine/tool. Save this document, refer to it often, and use it to instruct other operators.

Failure to read, understand and follow the instructions in this manual may result in fire or serious personal injury—including amputation, electrocution, or death.

The owner of this machine/tool is solely responsible for its safe use. This responsibility includes but is not limited to proper installation in a safe environment, personnel training and usage authorization, proper inspection and maintenance, manual availability and comprehension, application of safety devices, cutting/sanding/grinding tool integrity, and the usage of personal protective equipment.

The manufacturer will not be held liable for injury or property damage from negligence, improper training, machine modifications or misuse.



WARNING!

Some dust created by power sanding, sawing, grinding, drilling, and other construction activities contains chemicals known to the State of California to cause cancer, birth defects or other reproductive harm. Some examples of these chemicals are:

- Lead from lead-based paints.
- Crystalline silica from bricks, cement and other masonry products.
- Arsenic and chromium from chemically-treated lumber.

Your risk from these exposures varies, depending on how often you do this type of work. To reduce your exposure to these chemicals: Work in a well ventilated area, and work with approved safety equipment, such as those dust masks that are specially designed to filter out microscopic particles.

Contents

INTRODUCTION	2	ACCESSORIES	30
Woodstock Technical Support	2	Mill-Drill Accessories	30
Machine Specifications	3	MAINTENANCE	31
Identification	5	General	31
Controls & Components	6	Cleaning & Protecting	31
SAFETY	8	Lubrication	32
Standard Machinery Safety Instructions	8	Replacing DRO Battery	34
Additional Safety for Mills/Drills	10	SERVICE	35
ELECTRICAL	11	General	35
Circuit Requirements	11	Adjusting Gibs	35
Grounding Requirements	12	Adjusting Leadscrew Backlash	36
Extension Cords	12	Brush Replacement	37
SETUP	13	Troubleshooting.....	38
Unpacking	13	Electrical Safety Instructions.....	41
Items Needed for Setup	13	M1116 Electrical Components	42
Inventory	14	M1116 Wiring Diagram.....	43
Cleaning Machine.....	15	PARTS	44
Machine Placement	16	Column.....	44
Lifting & Moving.....	17	Control Panel	46
Bench Mounting.....	18	Headstock	47
Assembly.....	19	Tools & Chip Guard	49
Joining Drill Chuck & Arbor.....	19	Labels & Cosmetics	50
Lubrication	19	WARRANTY	53
Test Run.....	20		
Spindle Break-In	21		
Inspections & Adjustments	21		
OPERATIONS	22		
General	22		
Downfeed Controls.....	23		
Headstock Movement.....	24		
Table Travel	25		
DRO Components	26		
Installing/Removing Tooling	27		
Setting Spindle Speed	28		





INTRODUCTION

Woodstock Technical Support

This machine has been specially designed to provide many years of trouble-free service. Close attention to detail, ruggedly built parts and a rigid quality control program assure safe and reliable operation.

Woodstock International, Inc. is committed to customer satisfaction. Our intent with this manual is to include the basic information for safety, setup, operation, maintenance, and service of this product.

We stand behind our machines! In the event that questions arise about your machine, please contact Woodstock International Technical Support at (360) 734-3482 or send e-mail to: tech-support@shopfox.biz. Our knowledgeable staff will help you troubleshoot problems and process warranty claims.

If you need the latest edition of this manual, you can download it from <http://www.shopfox.biz>.
If you have comments about this manual, please contact us at:

Woodstock International, Inc.
Attn: Technical Documentation Manager
P.O. Box 2309
Bellingham, WA 98227
Email: manuals@woodstockint.com



MACHINE SPECIFICATIONS



© Woodstock International, Inc. • Phone #: (800) 840-8420 • Web: www.woodstockint.com

MODEL M1116 VARIABLE-SPEED MILL/DRILL WITH DRO

Product Dimensions

Weight..... 161 lbs.
 Width (side-to-side) x Depth (front-to-back) x Height..... 25-1/2 x 19-1/2 x 32-1/2 in.
 Footprint (Length x Width)..... 11 x 9 in.
 Space Required for Full Range of Movement (Width x Depth)..... 39 x 19-1/2 in.

Shipping Dimensions

Type..... Wood Crate
 Content..... Machine
 Weight..... 204 lbs.
 Length x Width x Height..... 24 x 22 x 32 in.
 Must Ship Upright..... Yes

Electrical

Power Requirement..... 110V, Single-Phase, 60 Hz
 Full-Load Current Rating..... 8A
 Minimum Circuit Size..... 15A
 Connection Type..... Cord & Plug
 Power Cord Included..... Yes
 Power Cord Length..... 6 ft.
 Power Cord Gauge..... 16 AWG
 Plug Included..... Yes
 Included Plug Type..... 5-15
 Switch Type..... ON/OFF Push Button Switch w/Safety Cover

Motors

Main

Horsepower..... 600W (3/4 HP)
 Phase..... Single-Phase
 Amps..... 10A
 Speed..... 4500 RPM
 Type..... High-Torque, Low-Noise DC
 Power Transfer Gear Drive
 Bearings..... Sealed & Permanently Lubricated
 Centrifugal Switch/Contacts Type..... N/A



Main Specifications

Operation Info

Spindle Travel.....	2 in.
Max Distance Spindle to Column.....	6-5/8 in.
Max Distance Spindle to Table.....	8-3/4 in.
Longitudinal Table Travel (X-Axis).....	13-1/8 in.
Cross Table Travel (Y-Axis).....	4-1/2 in.
Vertical Head Travel (Z-Axis).....	8-1/4 in.
Head Tilt (Left/Right).....	45 deg.
Drilling Capacity for Cast Iron.....	5/8 in.
Drilling Capacity for Steel.....	1/2 in.
End Milling Capacity.....	5/8 in.
Face Milling Capacity.....	2 in.

Table Info

Table Length.....	19-3/4 in.
Table Width.....	5-3/4 in.
Table Thickness.....	1-7/8 in.
Table Height (from Floor/Base).....	6 in.
Number of T-Slots.....	3
T-Slot Size.....	3/8 in.
T-Slots Centers.....	1-1/2 in.
X/Y-Axis Travel per Handwheel Revolution.....	0.1 in.
Z-Axis Travel per Handwheel Revolution.....	0.166 in.

Spindle Info

Spindle Taper.....	R-8
Number of Vertical Spindle Speeds.....	Variable
Range of Vertical Spindle Speeds.....	50 - 200 RPM
Quill Diameter.....	2.36 in.
Drawbar Thread Size.....	7/16-20
Drawbar Length.....	9-7/8 in.
Spindle Bearings.....	Tapered Roller Bearings

Construction

Spindle Housing/Quill.....	Cast Iron
Table.....	Cast Iron
Head.....	Cast Iron
Column/Base.....	Cast Iron
Paint Type/Finish.....	Enamel

Other

Country of Origin	China
Warranty	2 Years
Approximate Assembly & Setup Time	30 min.
Serial Number Location	ID Label
ISO 9001 Factory	Yes

Identification

Become familiar with the names and locations of the controls and features shown below to better understand the instructions in this manual.

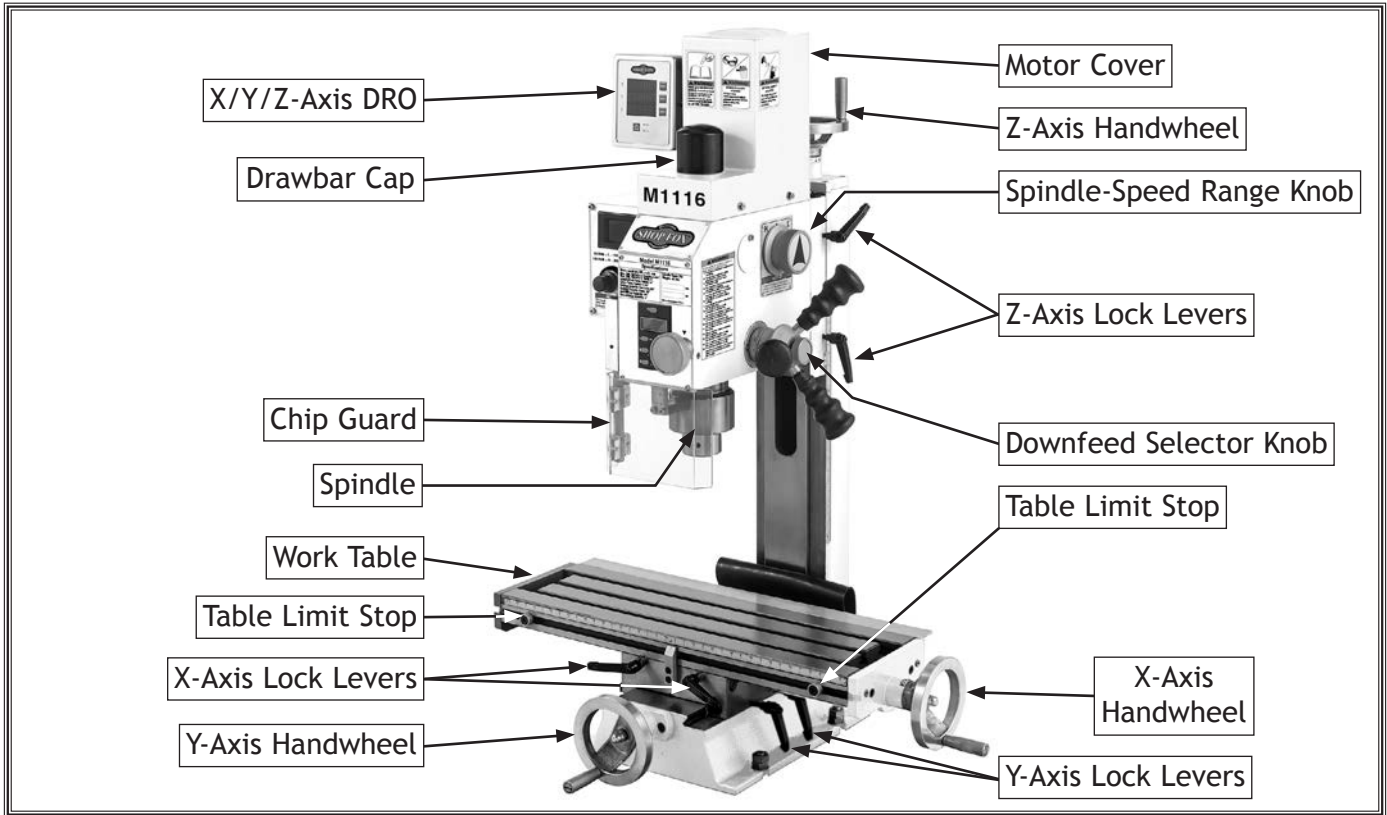

Figure 1. M1116 main identification.



Figure 2. M1116 headstock identification.

Controls & Components

Refer to Figures 3-4 and the following descriptions to become familiar with the basic controls and components of this machine. Understanding these items and how they work will help you understand the rest of the manual and stay safe when operating this machine.

- A. **Spindle Speed Range Knob:** Selects low gear "L" for maximum torque from 50-1000 RPM, or high gear "H" for 100-2000 RPM.
- B. **Z-Axis Handwheel:** Raises and lowers headstock.
- C. **Z-Axis Handwheel Graduated Collar:** Displays distance of Z-axis headstock travel in 0.002" increments. One full revolution is equal to 0.200" of headstock travel.
- D. **Z-Axis Lock Levers:** Lock position of headstock to column.
- E. **Downfeed Selector Knob:** Selects fine or coarse downfeed controls. When loosened, coarse downfeed is engaged; when tightened, fine downfeed is engaged.
- F. **Coarse Downfeed Handles:** Typically used for drilling operations for rapid drilling or plunge cutting. Spring-assisted return automatically returns spindle to top position when released.

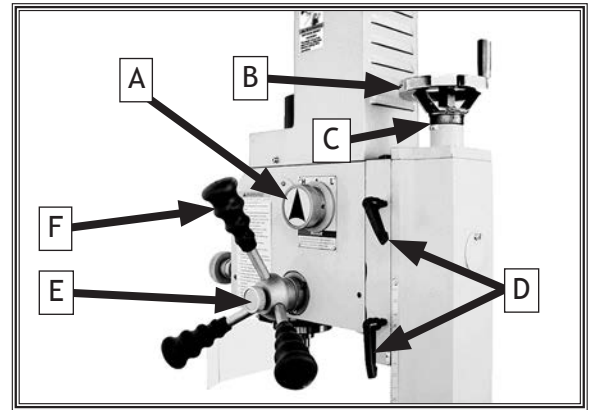
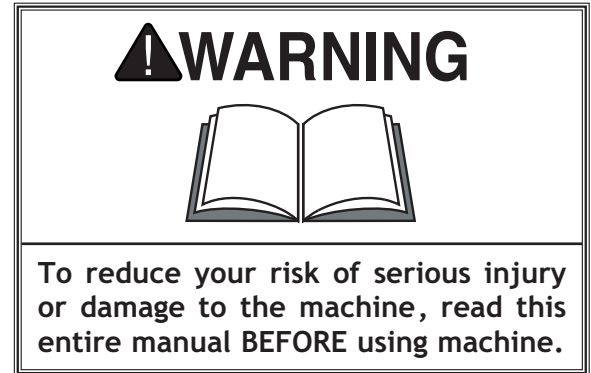

Figure 3. M1116 controls (right side).

Model M1116 (For Machines Mfd. Since 06/17)

- G. **Drawbar Cap/Drawbar:** Drawbar secures collets and tooling in the spindle.
- H. **Graduated Collar (Fine Downfeed):** Displays quill travel in 0.001" increments when the fine downfeed handwheel is used. One full revolution is equal to 0.100" of quill travel.
- I. **Fine Downfeed Handwheel:** Moves spindle up and down for precise Z-axis control when milling. Micrometer collar is graduated in increments of 0.001".
- J. **Spindle Depth DRO:** Displays a precise reading of vertical positioning of spindle. It can be zeroed at any position and manually increased or decreased independent of spindle position when operation requires it.
- K. **X-Axis Handwheel:** Manually moves table along X-axis (left to right).
- L. **X-Axis Handwheel Graduated Collar:** Displays distance of X-axis table travel in 0.002" increments. One full revolution is equal to 0.200" of table travel.
- M. **X-Axis Lock Levers:** Tighten to prevent X-axis table movement for increased rigidity during operations when X-axis should not move.
- N. **Y-Axis Handwheel:** Manually moves table along Y-axis (front to back).
- O. **Y-Axis Handwheel Graduated Collar:** Displays distance of Y-axis cross slide travel in 0.002" increments. One full revolution is equal to 0.200" of table travel.
- P. **Quill Lock Lever:** Locks vertical position of quill when tightened.
- Q. **OFF Button:** Stops spindle rotation.
- R. **Variable Spindle-Speed Dial:** Controls spindle speed from 50–1000 RPM in low range, and 100–2000 RPM in high range.
- S. **ON Button:** Push button to turn machine *ON*.
- T. **Spindle-Speed Tachometer:** Displays spindle speed RPM.

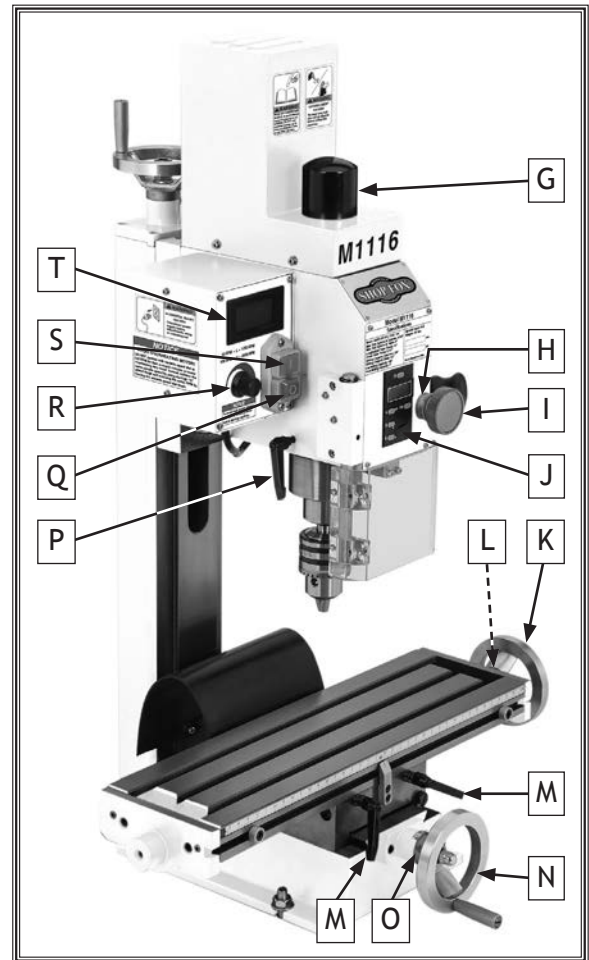

Figure 4. M1116 controls (front).

SAFETY

For Your Own Safety, Read Manual Before Operating Machine

The purpose of safety symbols is to attract your attention to possible hazardous conditions. This manual uses a series of symbols and signal words intended to convey the level of importance of the safety messages. The progression of symbols is described below. Remember that safety messages by themselves do not eliminate danger and are not a substitute for proper accident prevention measures—this responsibility is ultimately up to the operator!



Indicates an imminently hazardous situation which, if not avoided, **WILL** result in death or serious injury.



Indicates a potentially hazardous situation which, if not avoided, **COULD** result in death or serious injury.



Indicates a potentially hazardous situation which, if not avoided, **MAY** result in minor or moderate injury.

NOTICE

This symbol is used to alert the user to useful information about proper operation of the equipment or a situation that may cause damage to the machinery.

Standard Machinery Safety Instructions

OWNER'S MANUAL. Read and understand this owner's manual **BEFORE** using machine.

TRAINED OPERATORS ONLY. Untrained operators have a higher risk of being hurt or killed. Only allow trained/supervised people to use this machine. When machine is not being used, disconnect power, remove switch keys, or lock-out machine to prevent unauthorized use—especially around children. Make workshop kid proof!

DANGEROUS ENVIRONMENTS. Do not use machinery in areas that are wet, cluttered, or have poor lighting. Operating machinery in these areas greatly increases the risk of accidents and injury.

MENTAL ALERTNESS REQUIRED. Full mental alertness is required for safe operation of machinery. Never operate under the influence of drugs or alcohol, when tired, or when distracted.

ELECTRICAL EQUIPMENT INJURY RISKS. You can be shocked, burned, or killed by touching live electrical components or improperly grounded machinery. To reduce this risk, only allow an electrician or qualified service personnel to do electrical installation or repair work, and always disconnect power before accessing or exposing electrical equipment.

DISCONNECT POWER FIRST. Always disconnect machine from power supply **BEFORE** making adjustments, changing tooling, or servicing machine. This eliminates the risk of injury from unintended startup or contact with live electrical components.

EYE PROTECTION. Always wear ANSI-approved safety glasses or a face shield when operating or observing machinery to reduce the risk of eye injury or blindness from flying particles. Everyday eyeglasses are not approved safety glasses.

WEARING PROPER APPAREL. Do not wear clothing, apparel, or jewelry that can become entangled in moving parts. Always tie back or cover long hair. Wear non-slip footwear to avoid accidental slips, which could cause loss of workpiece control.

HAZARDOUS DUST. Dust created while using machinery may cause cancer, birth defects, or long-term respiratory damage. Be aware of dust hazards associated with each workpiece material, and always wear a NIOSH-approved respirator to reduce your risk.

HEARING PROTECTION. Always wear hearing protection when operating or observing loud machinery. Extended exposure to this noise without hearing protection can cause permanent hearing loss.

REMOVE ADJUSTING TOOLS. Tools left on machinery can become dangerous projectiles upon startup. Never leave chuck keys, wrenches, or any other tools on machine. Always verify removal before starting!

INTENDED USAGE. Only use machine for its intended purpose—never make modifications without prior approval from Woodstock International. Modifying machine or using it differently than intended will void the warranty and may result in malfunction or mechanical failure that leads to serious personal injury or death!

AWKWARD POSITIONS. Keep proper footing and balance at all times when operating machine. Do not overreach! Avoid awkward hand positions that make workpiece control difficult or increase the risk of accidental injury.

CHILDREN & BYSTANDERS. Keep children and bystanders at a safe distance from the work area. Stop using machine if they become a distraction.

GUARDS & COVERS. Guards and covers reduce accidental contact with moving parts or flying debris—make sure they are properly installed, undamaged, and working correctly.

FORCING MACHINERY. Do not force machine. It will do the job safer and better at the rate for which it was designed.

NEVER STAND ON MACHINE. Serious injury may occur if machine is tipped or if the cutting tool is unintentionally contacted.

STABLE MACHINE. Unexpected movement during operation greatly increases risk of injury or loss of control. Before starting, verify machine is stable and mobile base (if used) is locked.

USE RECOMMENDED ACCESSORIES. Consult this owner's manual or the manufacturer for recommended accessories. Using improper accessories will increase risk of serious injury.

UNATTENDED OPERATION. To reduce the risk of accidental injury, turn machine **OFF** and ensure all moving parts completely stop before walking away. Never leave machine running while unattended.

MAINTAIN WITH CARE. Follow all maintenance instructions and lubrication schedules to keep machine in good working condition. A machine that is improperly maintained could malfunction, leading to serious personal injury or death.

CHECK DAMAGED PARTS. Regularly inspect machine for any condition that may affect safe operation. Immediately repair or replace damaged or mis-adjusted parts before operating machine.

MAINTAIN POWER CORDS. When disconnecting cord-connected machines from power, grab and pull the plug—NOT the cord. Pulling the cord may damage the wires inside, resulting in a short. Do not handle cord/plug with wet hands. Avoid cord damage by keeping it away from heated surfaces, high traffic areas, harsh chemicals, and wet/damp locations.

EXPERIENCING DIFFICULTIES. If at any time you experience difficulties performing the intended operation, stop using the machine! Contact Technical Support at (360) 734-3482.

Additional Safety for Mills/Drills

WARNING

The primary risks of operating a mill are as follows: You can be seriously injured or killed by getting clothing, jewelry, or long hair entangled with rotating cutter/spindle. You can be severely cut or have fingers amputated from contact with the rotating cutter. You can be blinded or struck by broken cutting tools, metal chips, workpieces, or adjustment tools thrown from the rotating spindle with great force. To reduce your risk of serious injury when operating this machine, completely heed and understand the following:

UNDERSTAND ALL CONTROLS. Make sure you understand the function and proper use of all controls before starting. This will help you avoid making mistakes that result in serious injury.

AVOIDING ENTANGLEMENT. DO NOT wear loose clothing, gloves, or jewelry, and tie back long hair. Keep all guards in place and secure. Always allow spindle to stop on its own. DO NOT stop spindle using your hand or any other object.

WEAR FACE SHIELD. Always wear a face shield in addition to safety glasses. This provides more complete protection for your face than safety glasses alone.

USE CORRECT SPINDLE SPEED. Follow recommended speeds and feeds for each size and type of cutting tool. This helps avoid tool breakage during operation and ensures best cutting results.

INSPECT CUTTING TOOL. Inspect cutting tools for sharpness, chips, or cracks before each use. Replace dull, chipped, or cracked cutting tools immediately.

PROPERLY SECURE CUTTER. Firmly secure cutting tool or drill bit so it does not fly out of spindle during operation.

POWER DISRUPTION. In the event of a local power outage during operation, turn spindle switch OFF to avoid a possible sudden startup once power is restored.

CLEAN MACHINE SAFELY. Metal chips or shavings can be razor sharp. DO NOT clear chips by hand or compressed air that can force chips farther into machine—use a brush or vacuum instead. Never clear chips while spindle is turning.

SECURE WORKPIECE TO TABLE. Clamp workpiece to table or secure in a vise mounted to table, so workpiece cannot unexpectedly shift or spin during operation. NEVER hold workpiece by hand during operation.

PROPERLY MAINTAIN MACHINE. Keep machine in proper working condition to help ensure that it functions safely and all guards and other components work as intended. Perform routine inspections and all necessary maintenance. Never operate machine with damaged or worn parts that can break or result in unexpected movement during operation.

DISCONNECT POWER FIRST. To reduce risk of electrocution or injury from unexpected start-up, make sure mill/drill is turned OFF, disconnected from power, and all moving parts have come to a complete stop before changing cutting tools or starting any inspection, adjustment, or maintenance procedure.

REMOVE CHUCK KEY & SPINDLE TOOLS. Always remove chuck key, drawbar wrench, and other tools used on the spindle immediately after use. This will prevent them from being thrown by the spindle upon startup.

ELECTRICAL

Circuit Requirements

This machine must be connected to the correct size and type of power supply circuit, or fire or electrical damage may occur. Read through this section to determine if an adequate power supply circuit is available. If a correct circuit is not available, a qualified electrician **MUST** install one before you can connect the machine to power.

A power supply circuit includes all electrical equipment between the breaker box or fuse panel in the building and the machine. The power supply circuit used for this machine must be sized to safely handle the full-load current drawn from the machine for an extended period of time. (If this machine is connected to a circuit protected by fuses, use a time delay fuse marked D.)

Full-Load Current Rating

The full-load current rating is the amperage a machine draws at 100% of the rated output power. On machines with multiple motors, this is the amperage drawn by the largest motor or sum of all motors and electrical devices that might operate at one time during normal operations.

Full-Load Current Rating at 110V8 Amps

Circuit Requirements for 110V

This machine is prewired to operate on a power supply circuit that has a verified ground and meets the following requirements:

- Circuit Type 110V/120V, 60 Hz, Single-Phase
- Circuit Size 15 Amps
- Plug/Receptacle NEMA 5-15

⚠ WARNING

The machine must be properly set up before it is safe to operate. **DO NOT** connect this machine to the power source until instructed to do so later in this manual.

⚠ WARNING



Incorrectly wiring or grounding this machine can cause electrocution, fire, or machine damage. To reduce this risk, only an electrician or qualified service personnel should do any required electrical work on this machine.

NOTICE

The circuit requirements listed in this manual apply to a dedicated circuit—where only one machine will be running at a time. If this machine will be connected to a shared circuit where multiple machines will be running at the same time, consult with an electrician to ensure that the circuit is properly sized for safe operation.

ELECTRICAL

Grounding Requirements

This machine **MUST** be grounded. In the event of certain types of malfunctions or breakdowns, grounding provides a path of least resistance for electric current to travel—in order to reduce the risk of electric shock.

Improper connection of the equipment-grounding wire will increase the risk of electric shock. The wire with green insulation (with/without yellow stripes) is the equipment-grounding wire. If repair or replacement of the power cord or plug is necessary, do not connect the equipment-grounding wire to a live (current carrying) terminal.

Check with a qualified electrician or service personnel if you do not understand these grounding requirements, or if you are in doubt about whether the tool is properly grounded. If you ever notice that a cord or plug is damaged or worn, disconnect it from power, and immediately replace it with a new one.

For 110V Connection

This machine is equipped with a power cord with an equipment-grounding wire and NEMA 5-15 grounding plug (see figure). The plug must only be inserted into a matching receptacle that is properly installed and grounded in accordance with local codes and ordinances.

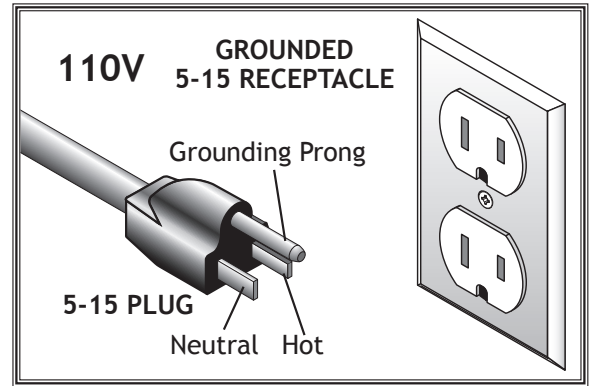
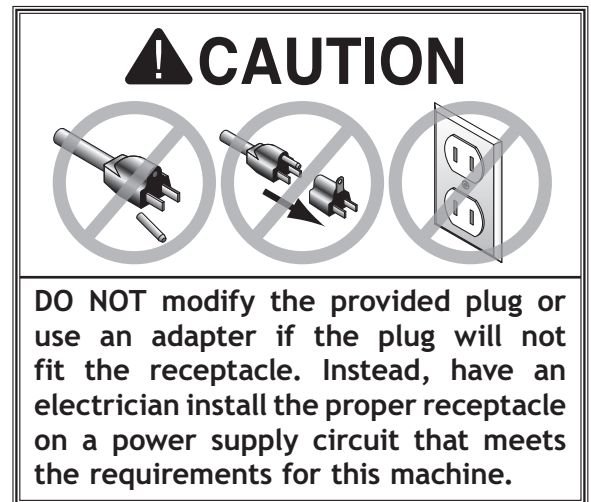

Figure 5. NEMA 5-15 plug & receptacle.



Extension Cords

We do not recommend using an extension cord with this machine. Extension cords cause voltage drop, which may damage electrical components and shorten motor life. Voltage drop increases with longer extension cords and smaller gauge sizes (higher gauge numbers indicate smaller sizes).

Any extension cord used with this machine must contain a ground wire, match the required plug and receptacle, and meet the following requirements:

- Minimum Gauge Size at 110V 14 AWG
- Maximum Length (Shorter is Better)..... 50 ft.

ELECTRICAL

SETUP

Unpacking

This machine has been carefully packaged for safe transportation. If you notice the machine has been damaged during shipping, please contact your authorized Shop Fox dealer immediately.

Items Needed for Setup

The following are needed to complete the setup process, but are not included with machine.

Description	Qty
• Additional People.....	1
• Safety Glasses.....	1
• Cleaner/Degreaser (Page 15)	As Needed
• Disposable Shop Rags	As Needed
• Forklift	1
• Lifting Sling (rated for at least 300 lbs.) (Page 17) .	1
• Mounting Hardware (Page 18).....	As Needed
• Brass Hammer (Page 27).....	1
• Mineral Spirits (Page 19).....	As Needed
• Wood Block (Page 19)	1



!WARNING
SUFFOCATION HAZARD!
 Immediately discard all plastic bags and packing materials to eliminate choking/suffocation hazards for children and animals.



!WARNING
 This machine presents serious injury hazards to untrained users. Read through this entire manual to become familiar with the controls and operations before starting the machine!



!WARNING
 Wear safety glasses during entire setup process!



!WARNING
 USE helpers or power lifting equipment to lift this machine. Otherwise, serious personal injury may occur.

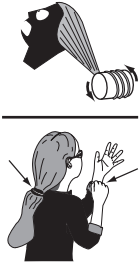

!WARNING
ENTANGLEMENT HAZARD!
 Tie back long hair, roll up sleeves, and remove loose clothing, jewelry, or gloves to prevent getting caught in moving parts.

SETUP

Inventory

The following is a list of items shipped with your machine. Before beginning setup, lay these items out and inventory them.

Note: *If you cannot find an item on this list, carefully check around/inside the machine and packaging materials. Often, these items get lost in packaging materials while unpacking or they are pre-installed at the factory.*

Inventory (Figure 6)	Qty
A. Handwheel Handles w/Shoulder Screws	3
B. Bottle for Oil	1
C. Toolbox	1
D. Drill Chuck Arbor R8 x B16	1
E. Spindle Pin	1
F. Standard Screwdriver #2	1
G. Phillips Screwdriver #2	1
H. Open-End Wrench 8/10mm	1
I. Open-End Wrench 12/14mm	1
J. Open-End Wrench 17/19mm	1
K. Drill Chuck 3-16mm w/Chuck Key	1
L. T-Bolt Assemblies M8-1.25 x 55	2
M. Hex Wrenches 2.5, 3, 4, 5, 6mm	1 Each

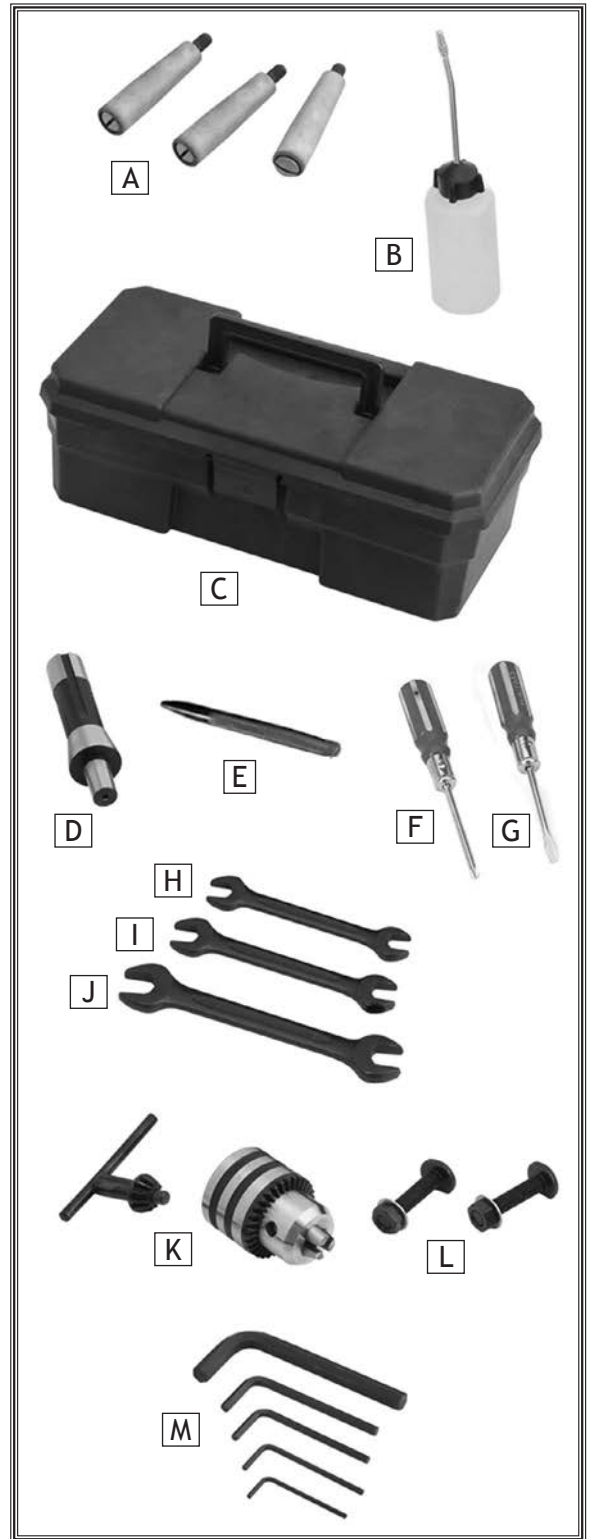

Figure 6. M1116 inventory.

Cleaning Machine

To prevent corrosion during shipment and storage of your machine, the factory has coated the bare metal surfaces of your machine with a heavy-duty rust prevention compound.

If you are unprepared or impatient, this compound can be difficult to remove. To ensure that the removal of this coating is as easy as possible, please gather the correct cleaner, lubricant, and tools listed below:

- Cleaner/degreaser designed to remove storage wax and grease
- Safety glasses & disposable gloves
- Solvent brush or paint brush
- Disposable Rags

To remove rust preventative coating, do these steps:

1. DISCONNECT MACHINE FROM POWER!
2. Put on safety glasses and disposable gloves.
3. Coat the rust preventative with a liberal amount of cleaner/degreaser, then let it soak for 5-10 minutes.
4. Wipe off surfaces. If your cleaner/degreaser is effective, the coating will wipe off easily.

Tip: An easier way to clean off thick coats of rust preventative from flat surfaces is to use a PLASTIC paint scraper to scrape off the majority of the coating before wiping it off with your rag. (Do not use a metal scraper or you may scratch your machine.)

5. Repeat cleaning steps as necessary until all of the compound is removed.
6. To prevent rust on freshly cleaned surfaces, immediately coat with a quality metal protectant.

! WARNING	
	<p>Gasoline and petroleum products have low flash points and can explode or cause fire if used to clean machinery. Avoid using these products to clean machinery. Many cleaning solvents are toxic if inhaled. Minimize your risk by only using these products in a well ventilated area.</p>

NOTICE
<p>In a pinch, automotive degreasers, mineral spirits or WD•40 can be used to remove rust preventative coating. Before using these products, though, test them on an inconspicuous area of your paint to make sure they will not damage it.</p>

SETUP

Machine Placement

Weight Load

Refer to the **Machine Specifications** for the weight of your machine. Make sure that the surface upon which the machine is placed will bear the weight of the machine, additional equipment that may be installed on the machine, and the heaviest workpiece that will be used. Additionally, consider the weight of the operator and any dynamic loading that may occur when operating the machine.

Space Allocation

Consider the largest size of workpiece that will be processed through this machine and provide enough space around the machine for adequate operator material handling or the installation of auxiliary equipment. With permanent installations, leave enough space around the machine to open or remove doors/covers as required by the maintenance and service described in this manual. See below for required space allocation.

Physical Environment

The physical environment where your machine is operated is important for safe operation and the longevity of its components. For best results, operate this machine in a dry environment that is free from excessive moisture, hazardous chemicals, airborne abrasives, or extreme conditions. Extreme conditions for this type of machinery are generally those where the ambient temperature range exceeds 41°-104°F; the relative humidity range exceeds 20-95% (non-condensing); or the environment is subject to vibration, shocks, or bumps.

Electrical Installation

Place this machine near an existing power source. Make sure all power cords are protected from traffic, material handling, moisture, chemicals, or other hazards. Make sure to leave access to a means of disconnecting the power source or engaging a lockout/tagout device.

Lighting

Lighting around the machine must be adequate enough that operations can be performed safely. Shadows, glare, or strobe effects that may distract or impede the operator must be eliminated.

SETUP

	<p>⚠ CAUTION</p> <p>Children or untrained people may be seriously injured by this machine. Only install in an access restricted location.</p>
---	--

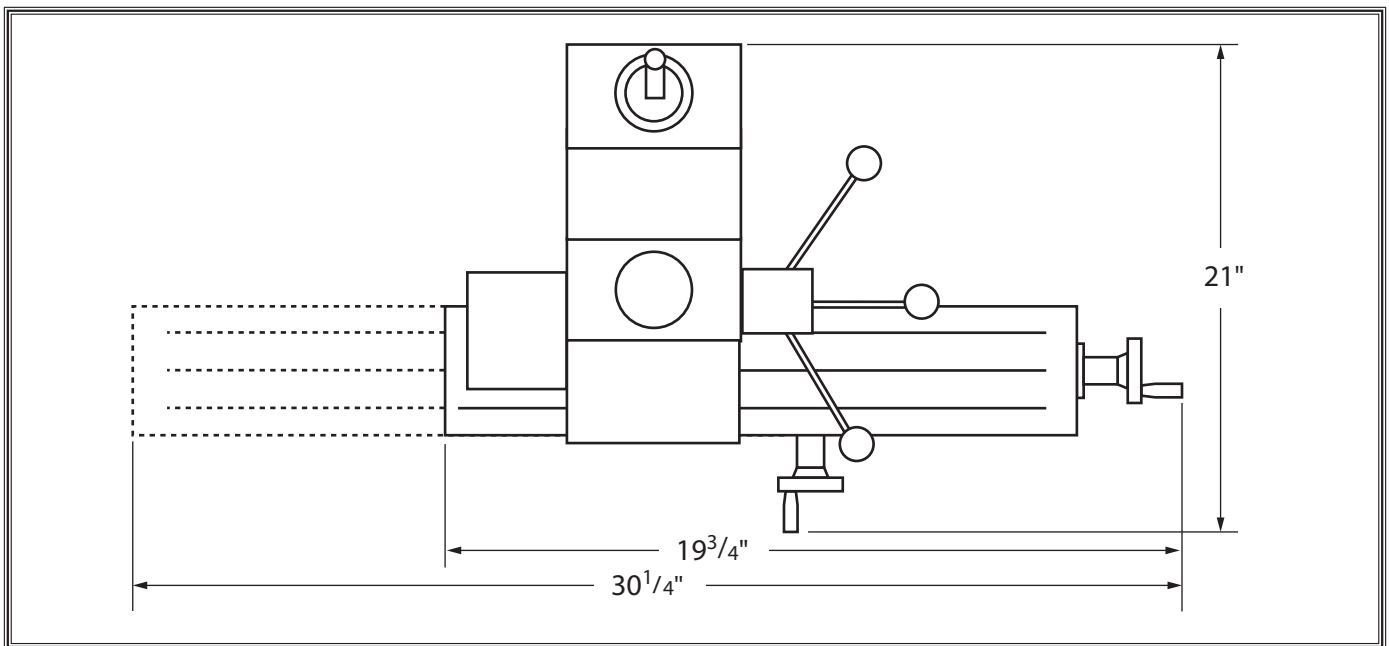

Figure 7. Working clearances.

Lifting & Moving

Use a forklift to lift the machine off the pallet and onto a suitable location.

The Model M1116 mill/drill can be mounted to a workbench or optional stand D4780 (see **Figure 8**). The stand is specifically designed for Model M1116 and comes with pre-drilled mounting holes.

To lift machine and place it in position, do these steps:

1. Place shipping crate next to workbench (or stand D4780) where machine will be placed.
2. Use vertical handwheel to raise headstock as far as possible (see **Figure 9**). Lock headstock in place to avoid sudden shifts during lifting.
3. Hang lifting sling from forklift fork and place it under headstock, as shown in **Figure 9**. **DO NOT** place sling over any controls or against any components that may be damaged from the force required for lifting.
4. Unbolt machine from pallet. Have an assistant on the ground steady machine to prevent it from swinging and lift it slightly off the pallet with forklift.
5. Carefully place machine onto workbench or optional stand D4780.
6. Mount machine to workbench following instructions in **Bench Mounting** on **Page 18**, or to stand following instructions included with stand.

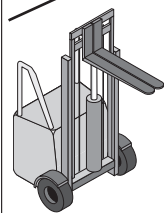
! WARNING
HEAVY LIFT!
 Straining or crushing injury may occur from improperly lifting the machine or some of its parts. To reduce this risk, get help from other people and use a forklift (or other lifting equipment) rated for weight of machine.



Figure 8. Optional stand D4780 for Model M1116.

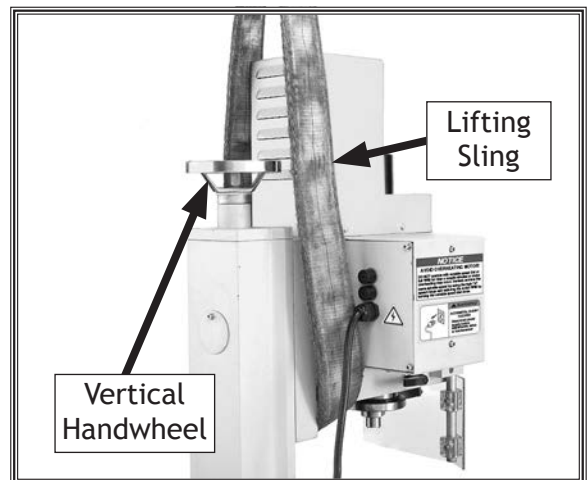

Figure 9. Headstock positioned for lifting.

SETUP

Bench Mounting

Number of Mounting Holes..... 4
 Diameter of Mounting Hardware Needed 1/2"

The base of this machine has mounting holes that allow it to be fastened to a workbench or other mounting surface to prevent it from moving during operation and causing accidental injury or damage.

The strongest mounting option is a "Through Mount" (see example) where holes are drilled all the way through the workbench—and hex bolts, washers, and hex nuts are used to secure the machine in place.

Another option is a "Direct Mount" (see example) where the machine is secured directly to the workbench with lag screws and washers.

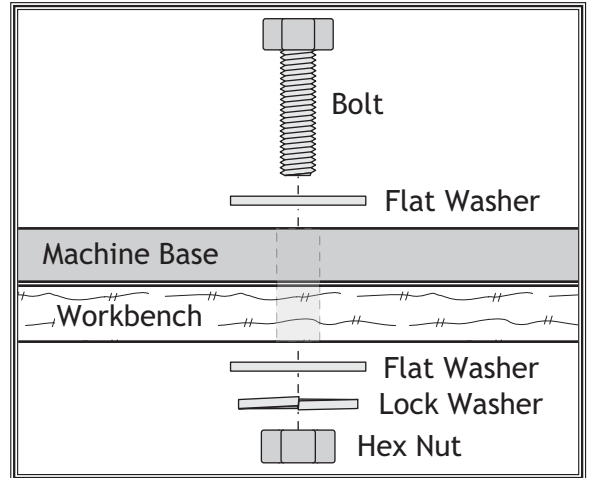

Figure 10. Typical "Through Mount" setup.

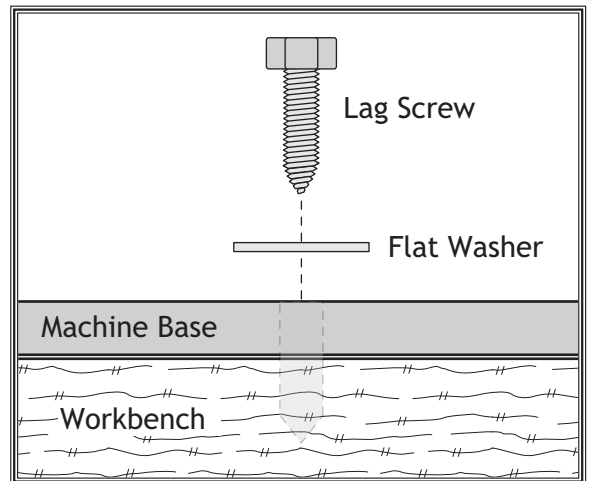

Figure 11. Typical "Direct Mount" setup.

Assembly

Except for the handwheel handles, the mill/drill is fully assembled at the factory.

Use a standard screwdriver to attach handwheel handles (see Figures 12-13).

Joining Drill Chuck & Arbor

A B16 x R8 arbor is included for the drill chuck that comes with this machine. The following procedure describes how to install the arbor in the chuck.

After the arbor is installed in the drill chuck, it is very difficult to separate the assembly. If you would like to use a different chuck in the future, we recommend getting a new arbor for that chuck.

IMPORTANT: DO NOT install the drill chuck and arbor into the spindle until AFTER the test run.

To join drill chuck and arbor, do these steps:

1. Use mineral spirits to clean drill chuck and arbor mating surfaces, especially the bore.
2. Retract chuck jaws completely into chuck.
3. Insert small end of arbor into chuck.
4. Hold assembly by arbor and tap chuck onto a block of wood with medium force, as illustrated in Figure 14.
5. Attempt to separate drill chuck and arbor by hand. If you can pull them apart, repeat Step 4.

Note: Refer to Installing/Removing Tooling section on Page 27 for installing arbor into spindle instructions.

Lubrication

The lubrication procedures highlighted in the Lubrication subsection of SECTION 6: MAINTENANCE must be completed before performing the test run or spindle break-in.

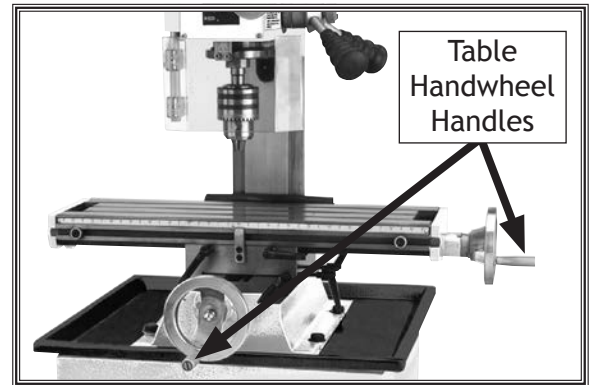

Figure 12. X- and Y-axis handwheel handles attached.

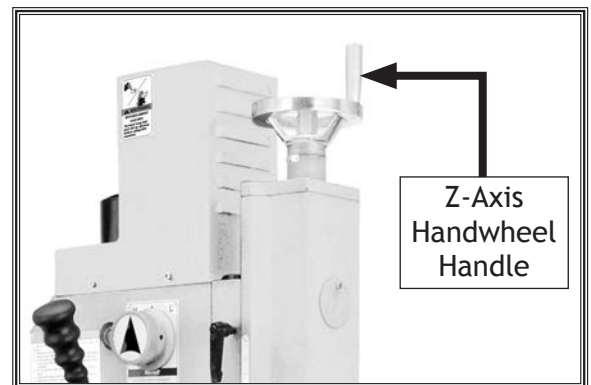

Figure 13. Z-axis handwheel handle attached.

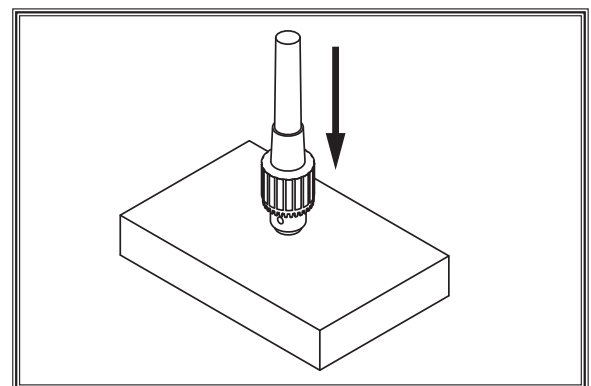

Figure 14. Tapping drill chuck/arbor on block of wood.

NOTICE

Damage caused by running the mill/drill without first properly lubricating headstock gears will not be covered under warranty.

SETUP

Test Run

Once assembly is complete, test run the machine to ensure it is properly connected to power and safety components are functioning properly.

If you find an unusual problem during the test run, immediately stop the machine, disconnect it from power, and fix the problem BEFORE operating the machine again. The **Troubleshooting** table in the **SERVICE** section of this manual can help.

The test run consists of verifying: 1) The motor powers up and runs correctly, 2) the chip guard works correctly.

1. Make sure all tools and objects used during setup are cleared away from machine.
2. Press OFF button (see **Figure 15**). This will help prevent unexpected startup when machine is connected to power.
3. Rotate variable spindle-speed dial to lowest setting.
4. Rotate spindle-speed range knob to low "L" gear setting (see **Figure 16**).

Note: When switching between gears, it may be necessary to rotate spindle by hand so gears will align and engage.

5. Connect mill/drill to power supply.
6. Press ON button. Spindle should begin to rotate clockwise (as viewed from top), and machine should run smoothly with little or no vibration or rubbing noises.
7. Press OFF button.
8. Open chip guard half way and press ON button. Machine should not start.
 - If machine does start (with chip guard opened half way), press OFF button and immediately disconnect power to machine. The chip guard safety feature is not working correctly. This safety feature must work properly before proceeding with regular operations. Refer to **Troubleshooting** table in this manual.

Congratulations! The Test Run is complete. Continue to **Spindle Break-In**.

⚠ WARNING

Serious injury or death can result from using this machine BEFORE understanding its controls and related safety information. DO NOT operate, or allow others to operate, machine until the information is understood.

⚠ WARNING

DO NOT start machine until all preceding setup instructions have been performed. Operating an improperly set up machine may result in malfunction or unexpected results that can lead to serious injury, death, or machine/property damage.

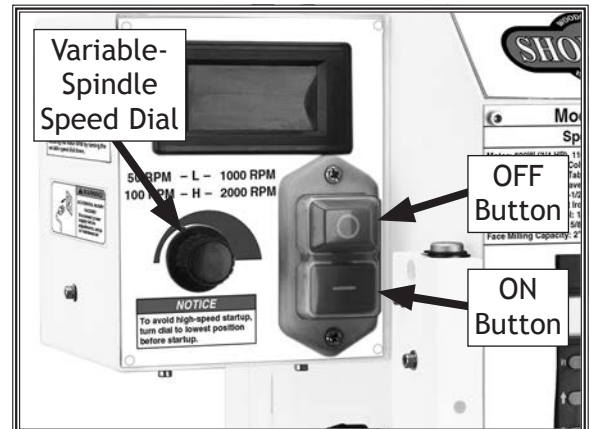

Figure 15. Location of mill/drill controls (front).

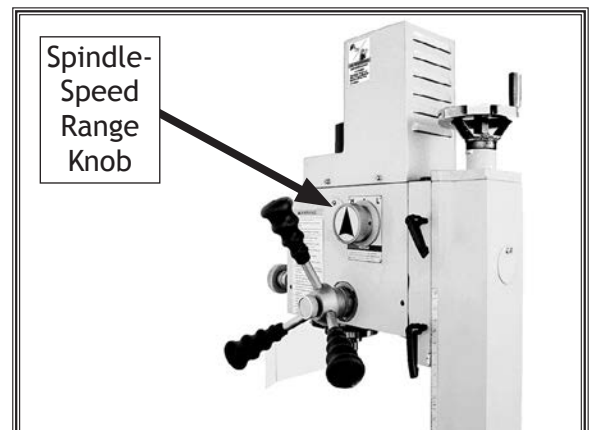

Figure 16. Rotate spindle-speed range knob right for low setting.

SETUP

Spindle Break-In

The spindle break-in procedure distributes lubrication throughout the bearings to reduce the risk of early bearing failure if there are any "dry" spots or areas where lubrication has settled in the bearings. You must complete this procedure before placing operational loads on the spindle for the first time when the machine is new or if it has been sitting idle for longer than 6 months.

Always start the spindle break-in at the lowest speed to minimize wear if there are dry spots. Allow the spindle to run long enough to warm up and distribute the bearing grease, then incrementally increase spindle speeds and repeat this process at each speed until reaching the maximum spindle speed. Following the break-in procedure in this progressive manner helps minimize any potential wear that could occur before lubrication is fully distributed.

To perform spindle break-in procedure, do these steps:

1. Successfully complete **Test Run** procedure beginning on **Page 20**.
2. Rotate spindle variable-speed dial to 50 RPM and spindle-speed range knob to low "L".
3. Press ON button.
4. Run spindle for minimum of 10 minutes.
5. Without stopping spindle, use spindle-speed dial to run machine at 500 and 1000 RPM for 10 minutes each.
6. Press OFF button.
7. Rotate spindle-speed dial to 100 RPM and spindle-speed range knob to high "H".
8. Press ON button.
9. Run machine for a minimum of 10 minutes.
10. Without stopping spindle, use spindle-speed dial to run machine at 1000 and 2000 RPM for 10 minutes each.
11. Press OFF button.

The spindle break-in of the machine is now complete!

NOTICE

You must complete this procedure to maintain the warranty. Failure to do this could cause rapid wear-and-tear of spindle bearings once they are placed under load.

Inspections & Adjustments

The following adjustments were performed at the factory before the machine was shipped:

- Gib Adjustments Page 35
- Leadscrew Backlash Adjustments Page 36

Be aware that these can change during the shipping process. Pay careful attention to these adjustments when first operating the machine. If you find that the adjustments are not set to your personal preferences, re-adjust them.

OPERATIONS

General

This machine will perform many types of operations that are beyond the scope of this manual. Many of these operations can be dangerous or deadly if performed incorrectly.

The instructions in this section are written with the understanding that the operator has the necessary knowledge and skills to operate this machine. If at any time you are experiencing difficulties performing any operation, stop using the machine!

The overview below provides the novice machine operator with a basic understanding of how the machine is used during operation, so the machine controls/components discussed later in this manual are easier to understand. Due to its generic nature, this overview is **NOT** intended to be an instructional guide.

To complete typical operation, operator does the following:

1. Examines workpiece to make sure it is suitable for cutting/drilling.
2. Puts on personal protective equipment.
3. Securely clamps workpiece to table.
4. With machine disconnected from power, installs correct tooling.
5. Adjusts headstock height above table.
6. Rotates spindle-speed dial to lowest setting.
7. Selects correct gear setting on gearbox.
8. Connects machine to power and presses ON button and rotates spindle-speed dial to correct spindle speed.
9. Uses downfeed controls or table controls to perform operation.
10. Presses OFF button and waits for spindle to completely stop before removing workpiece, changing tooling, or changing spindle speeds.

WARNING



To reduce your risk of serious injury or damage to the machine, read this entire manual **BEFORE** using machine.

WARNING



To reduce the risk of eye injury, always wear ANSI-approved safety glasses and face shield while operating this machine.

NOTICE

If you are an inexperienced operator, we strongly recommend that you read books or trade articles, or seek training from an experienced operator of this type of machinery before performing unfamiliar operations. Above all, safety must come first!

Downfeed Controls

Identification (Figure 17)

- A. Quill Lock Lever
- B. Spindle Depth DRO
- C. Fine Downfeed Handwheel
- D. Coarse Downfeed Handle
- E. Downfeed Selector Knob

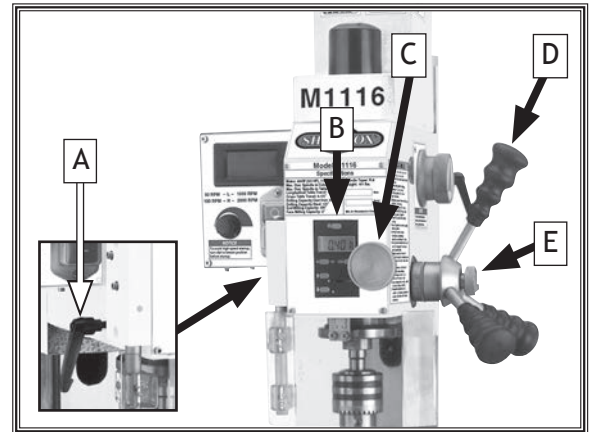

Figure 17. Identification of downfeed controls.

Using Spindle Depth DRO

1. Press Power/⏻ button (see Figure 18). A reading should appear on display.
2. Press in/mm button to select inches or millimeters. Each press of button switches between units.
3. Press ZERO to "zero" readout at any time. Current reading will be cleared and scale will reset to 0.00.

To increase or decrease reading, press ↑ or ↓ button. This is useful when calibrating mill/drill to known dimensions on a workpiece.

4. Press Power/⏻ button when operation is complete.

Using Coarse Downfeed

1. Loosen downfeed selector knob to engage coarse downfeed handles.
2. Loosen quill lock lever.
3. Turn on spindle depth DRO and zero it out.
4. Use coarse downfeed handles to raise and lower spindle while referencing spindle depth DRO for precise movement.

Using Fine Downfeed

1. Tighten downfeed selector knob to engage fine downfeed handwheel.
2. Loosen quill lock lever.
3. Turn on spindle depth DRO and zero it out.
4. Rotate fine downfeed handwheel to raise and lower spindle while referencing spindle depth DRO for precise movement.

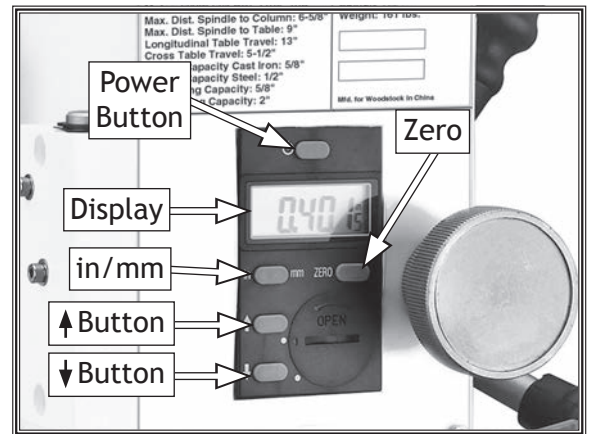

Figure 18. Identification of spindle depth DRO controls.

Headstock Movement

The headstock moves in the following ways:

- Travels up and down the column (Z-axis).
- Tilts 45° left or right relative to the table.

Raising/Lowering Headstock

1. DISCONNECT MACHINE FROM POWER!
2. Loosen both Z-axis lock levers shown in **Figure 19**.
3. Use vertical handwheel shown in **Figure 19** to adjust headstock height.
4. Retighten lock levers.

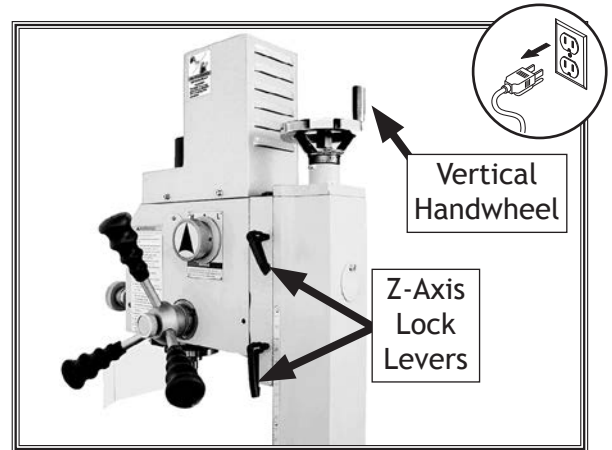

Figure 19. Location of Z-axis lock levers.

Tilting Headstock

Tools Needed

	Qty
Wrench 19mm	1
Wrench 14mm	1

To tilt headstock, do these steps:

1. DISCONNECT MACHINE FROM POWER!
2. Support headstock with one hand, then loosen headstock center bolt and angle lock nut (see **Figure 20**).
3. While watching tilt scale, rotate headstock to required angle, then retighten center bolt and angle lock nut to secure headstock.

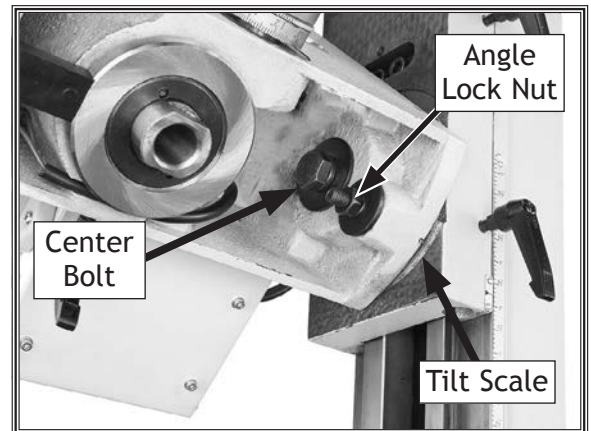

Figure 20. Headstock tilt controls.

Table Travel

The table travels in two directions and is controlled by handwheels, as illustrated in **Figure 21**:

- X-axis (longitudinal)
- Y-axis (cross)

Graduated Dials

The handwheels have graduated dials that are used to determine table movement in 0.002" increments, with one full revolution equalling 0.100".

Rotate graduated dial to a relative starting point (see **Figure 22**).

X-Axis Handwheel

Tool Needed	Qty
Hex Wrench 5mm	1

To use X-axis handwheel, do these steps:

1. Loosen both X-axis table locks shown in **Figure 23**.

Note: To re-adjust positioning of table locks, pull out on table lock handle and rotate.

2. Position table stops along front of table to restrict table travel.
3. Adjust X-axis graduated dial to zero, then use handwheel to move table.

Y-Axis Handwheel

The saddle does not have limit stops. To move the table along the Y-axis, loosen the Y-axis table locks shown in **Figure 23**, then use the handwheel in front of the table in the same manner as the X-axis handwheel.

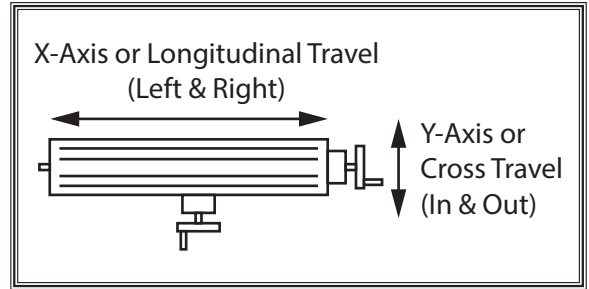

Figure 21. Possible directions of table travel.

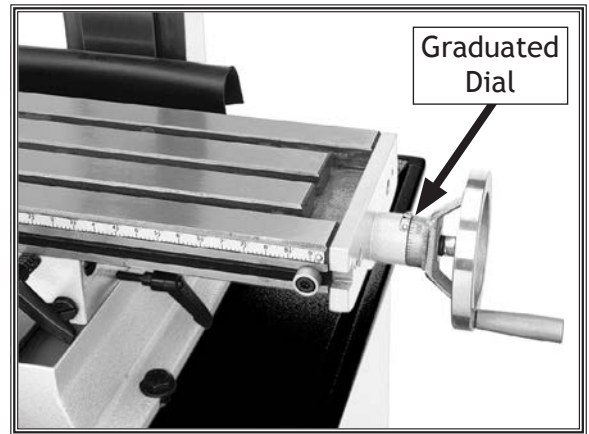

Figure 22. Graduated dial location.

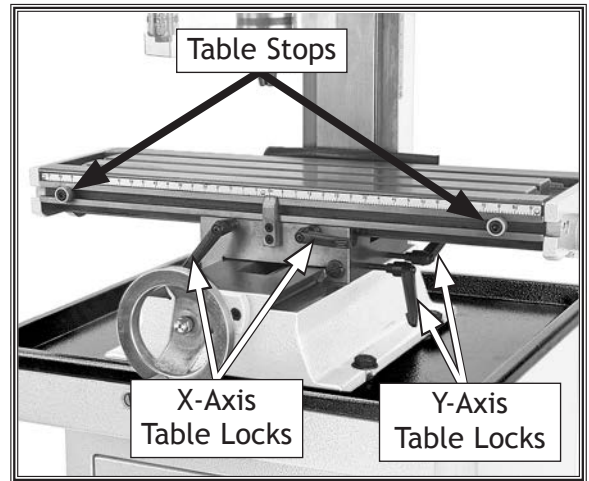

Figure 23. X- and Y-axis table travel locks.

OPERATIONS

DRO Components

Digital Readout (DRO)

The Model M1116 features a magnetically mounted DRO (see **Figure 24**) to measure X-axis (table), Y-axis (saddle), and Z-axis (column) travel.

Note: When placing the DRO, locate all cables so they do not interfere with machine operation and get pinched by moving components.

The X-axis sensor and scale are attached to the table. The Y-axis scale is attached to the saddle, and the Y-axis sensor is attached to the base. The Z-axis sensor and scale are attached to the column (see **Figure 25**).

Shielded cables run from each sensor to plugs on the back of the DRO (see **Figures 25–26**). The DRO connects to a 110V power supply with a dedicated power cord using a NEMA 1-15 plug.

Using the DRO

Refer to **Figure 27** for location of controls and display of the DRO.

- A. DRO displays current position of X-axis, Y-axis, and Z-axis in hundredths of a millimeter or thousandths of an inch.
- B. "X" value displays total X-axis travel from zero (0) along table.
- C. "Y" value displays total Y-axis travel from zero (0) along saddle.
- D. "Z" value displays total Z-axis travel from zero (0) along column.
- E. In/MM button allows users to choose measurement display in inches or millimeters.
- F. Green light indicates current display mode (inches or millimeters).
- G. ZERO buttons reset values at any point along the selected axis to 0.00.
- H. Magnetic mount.



Figure 24. DRO magnetically mounted to mill headstock.

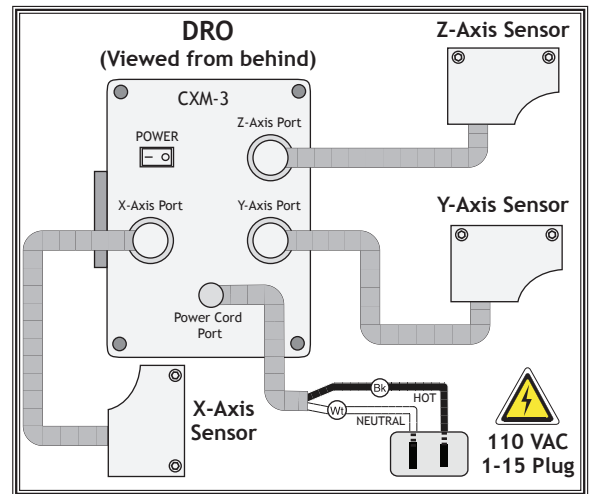

Figure 25. M1116 DRO wiring.

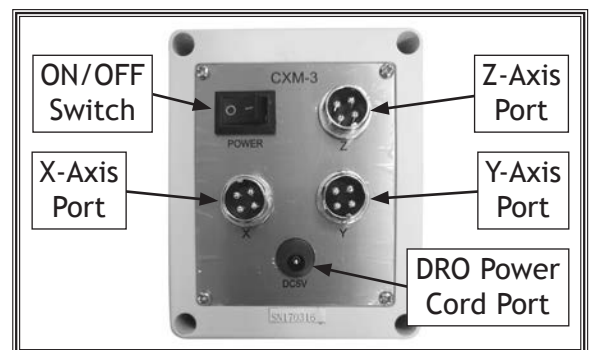

Figure 26. DRO cable connections (rear).



Figure 27. DRO controls and display.

Installing/Removing Tooling

The Model M1116 includes a 1-13mm drill chuck with an R8 arbor (see Figure 28).

Installing Tooling

Tools Needed	Qty
Spindle Pin	1
Wrench 8mm.....	1
Brass Hammer	1

To install tooling, do these steps:

1. DISCONNECT MACHINE FROM POWER!
2. Remove drawbar cap (see Figure 29).
3. Align tool slot (see Figure 30) with pin inside spindle, then insert tooling into spindle until in contacts drawbar.

Note: Height of drawbar inside spindle can be changed by rotating adjustment nut (see Figure 30).

4. From above, thread drawbar by hand into tooling.
5. Secure spindle with spindle pin and tighten drawbar with wrench, as shown in Figure 30.

Note: DO NOT overtighten drawbar.

6. Re-install drawbar cap.

Removing Tooling

1. DISCONNECT MACHINE FROM POWER!
2. Remove drawbar cap and secure spindle with spindle pin, as shown in Figure 30. Unthread drawbar from tooling one full rotation.

Note: DO NOT fully unthread tooling from drawbar or the drawbar and tool threads could be damaged in the next step.

3. Tap top of drawbar with brass hammer to unseat taper.
4. Hold tooling with one hand and unthread drawbar.

⚠ CAUTION

Cutting tools are sharp and can easily cause cutting injuries. Always protect your hands with leather gloves or shop rags when handling cutting tools.



Figure 28. 1-13mm drill chuck joined with R8 arbor.

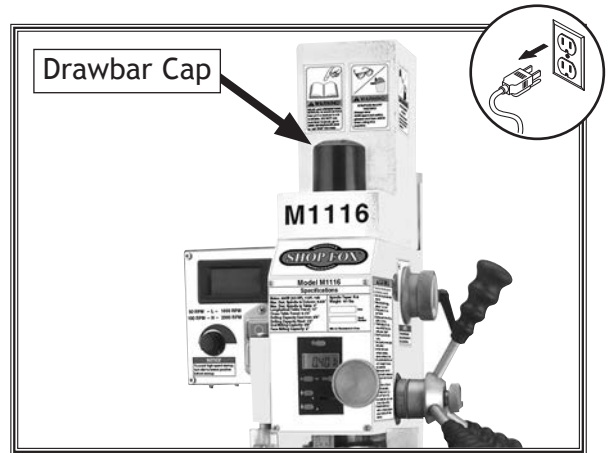

Figure 29. Location of drawbar cap.

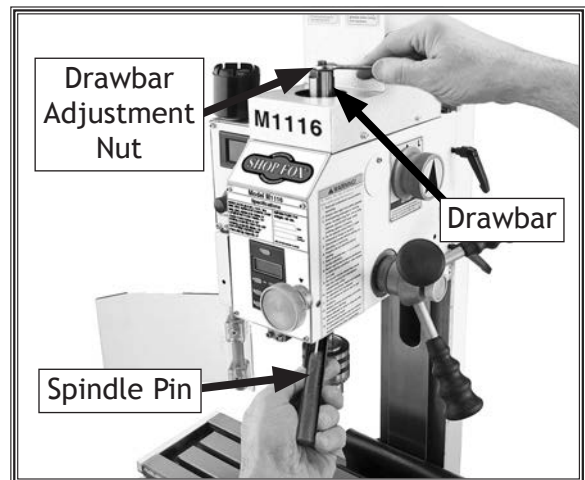

Figure 30. Components used when installing or removing tooling.

OPERATIONS

Setting Spindle Speed

Using the correct spindle speed is important for safe and satisfactory results, as well as maximizing tool life.

To set the spindle speed for operation, you will need to: 1) Determine the best spindle speed for the cutting/drilling task, and 2) adjust the gearbox knob and spindle-speed dial to produce determined speed.

Determining Spindle Speed

Many variables affect the optimum spindle speed to use for any given operation, but the two most important are the recommended cutting speed for the workpiece material and the diameter of the cutting tool, as noted in the formula shown in **Figure 31**.

Cutting speed, typically defined in feet per minute (FPM), is the speed at which the edge of a tool moves across the material surface.

A recommended cutting speed is an ideal speed for cutting a type of material in order to produce the desired finish and optimize tool life.

The books **Machinery's Handbook** or **Machine Shop Practice**, and some internet sites, provide excellent recommendations for which cutting speeds to use when calculating the spindle speed. These sources also provide a wealth of additional information about the variables that affect cutting speed and they are a good educational resource.

Also, there are a large number of easy-to-use spindle speed calculators that can be found on the internet. These sources will help you take into account the applicable variables in order to determine the best spindle speed for the operation.

<p>*Recommended $\frac{\text{Cutting Speed (FPM)} \times 12}{\text{Tool Dia. (in inches)} \times 3.14} = \text{Spindle Speed (RPM)}$ </p> <p>*Double if using carbide cutting tool</p>
--

Figure 31. Formula for determining best spindle speed.

Setting Spindle Speed

1. Shift spindle-speed range knob to either "L" (spindle speeds of 50–1000 RPM) or "H" (spindle speeds of 100–2000 RPM) (see **Figure 32**).

Note: *If necessary, rotate spindle by hand to mesh gears when changing ranges.*

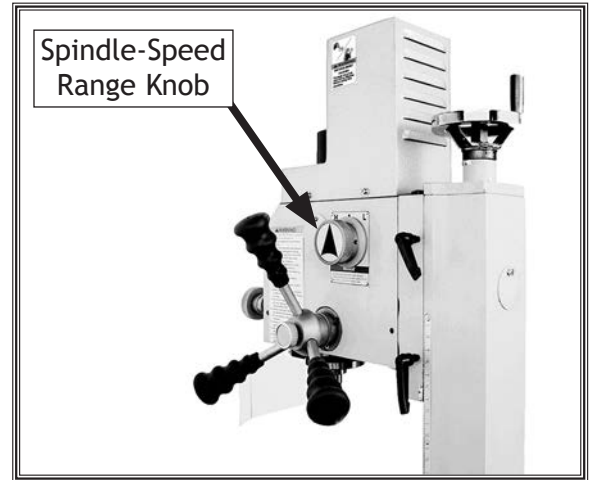

Figure 32. Select "L" or "H" to change spindle speed range.

2. Rotate variable-speed spindle dial fully counterclockwise to set spindle speed at lowest value (see **Figure 33**).
3. Press ON button.
4. Watch spindle speed tachometer readout and adjust variable-speed spindle dial as needed until desired RPM is reached.

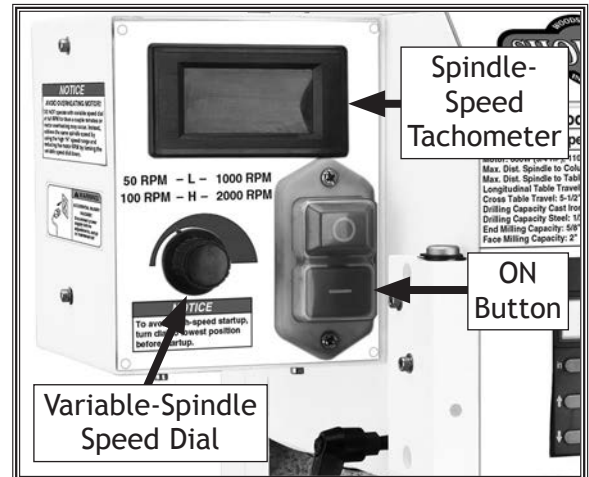

Figure 33. Spindle-speed controls.

NOTICE

Change spindle speed **ONLY** when the spindle is completely stopped. Otherwise, machine damage could occur.

ACCESSORIES

Mill-Drill Accessories

The following mill-drill accessories may be available through your local Woodstock International Inc. Dealer. If you do not have a dealer in your area, these products are also available through online dealers. Please call or e-mail Woodstock International Inc. Customer Service to get a current listing of dealers at: 1-800-840-8420 or at sales@woodstockint.com.

Both jaws on the Shop Fox **D4064 Precision Self-Centering Vise** move in equal and opposite directions so parts of varying size remain centered as long as the vise remains centered to the milling machine spindle. It's ideal for milling structural tubing of different diameters. Precision-ground dovetailed ways and an adjustable gib provide ultra-smooth operation. The jaws measure 4" wide by 1½" high. Maximum capacity is 4". Overall size is 10" long x 8½" wide x 4¼" high.

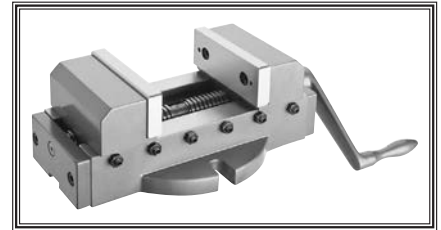

The Steelex **M1076 4" Rotary Table** is perfect for doing smaller, precision work, and features whole-degree scale on the dial, worm-gear drive, and a lash-adjustment screw.



The Steelex **M1079 12-Pc. R8 Collet Set** features collets that are precision ground to very close tolerances. Sizes include: 1/8", 3/16", 1/4", 5/16", 3/8", 7/16", 1/2", 9/16", 5/8", 11/16", 3/4" & 7/8". Switch out end mills the easy way—just attach the quick-change collet chuck to your mill and slip your end mill into the appropriate collet.



The Shop Fox **D4089 4-Pc. Machinist's Square Set** will prove useful in your shop. Each square is finely ground steel. All have common beam and blade widths and thicknesses which will allow them to be used in combination. 2", 3", 4" & 6" squares.

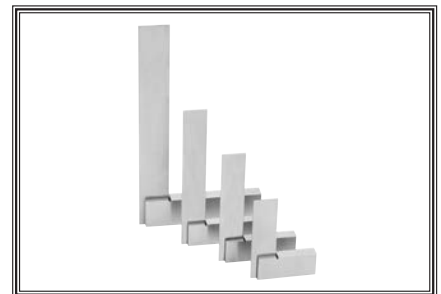

The Steelex **M1080 3/8" Clamping Kit** features case-hardened blocks, bolts, nuts and hold-downs. Clamping kit includes 24 3/8" studs, 6 pairs of step blocks, 6 1/2" T-nuts, 6 flange nuts, 4 coupling nuts, and 6 end hold-downs. Racks can be mounted to the wall or side of machine for easy access.

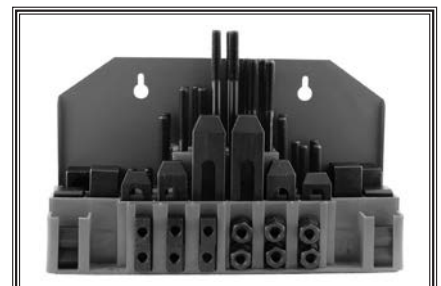

MAINTENANCE

General

For optimum performance from the machine, follow this maintenance schedule and refer to any specific instructions given in this section.

Daily Check:

- Loose mounting bolts.
- Damaged tooling.
- Clean debris and built up grime off of machine.
- Worn or damaged wires.
- Any other unsafe condition.

Every 8 Hours of Operation:

- Lubricate table and column ways (Page 32).
- Lubricate quill outside surface (Page 34).

Every 40 Hours of Operation:

- Lubricate table leadscrews (Page 33).

Every 90 Hours of Operation:

- Headstock gears (Page 33).
- Lubricate quill rack (Page 34).

Every 120 Hours of Operation:

- Lubricate Z-axis leadscrew (Page 32).

Cleaning & Protecting

Metal chips left on the machine that have been soaked with water-based coolant will invite oxidation and a gummy residue build-up around the moving parts. Use a brush and shop vacuum to remove chips and debris from the working surfaces of the mill/drill. Never blow off the mill/drill with compressed air, as this will force metal chips deep into the mechanisms and may cause injury to yourself or bystanders.

Remove any rust build-up from unpainted cast-iron surfaces of mill/drill and treat with a non-staining lubricant after cleaning.

Protect other unpainted cast-iron surfaces with regular applications of a product like South Bend Way Oil for Lathes.

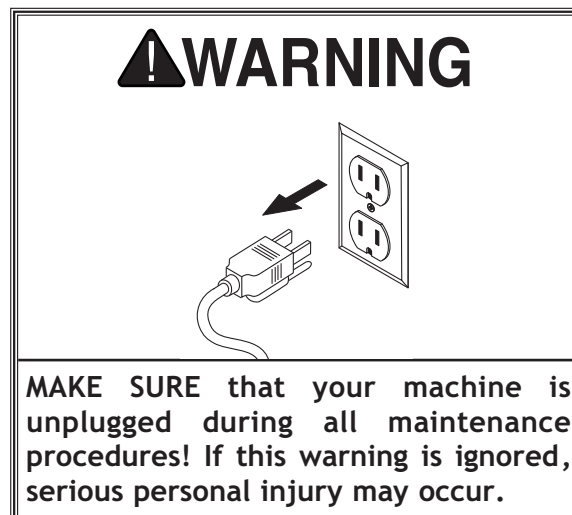

Figure 34. SB1365 South Bend Way Oil for Lathes.

MAINTENANCE

Lubrication

An essential part of lubrication is cleaning the components before lubricating them. This step is critical because grime and chips build up on lubricated components over time, which makes them hard to move.

Clean all exterior components in this section with mineral spirits, shop rags, and brushes before lubricating.

DISCONNECT MACHINE FROM POWER BEFORE PERFORMING LUBRICATION!

NOTICE

Follow reasonable lubrication practices as outlined in this manual. Failure to do so could lead to premature failure of machine and will void warranty.

Table and Column Ways

Lube TypeModel SB1365 or ISO 68 Equivalent
 Lube Amount..... Thin Coat
 Lubrication Frequency8 hrs. of Operation

Regular lubrication will ensure mill/drill performs at its highest potential. Regularly wipe table and column ways with recommended lubrication, then move components back and forth several times to ensure smooth movements (see Figures 35-37).

Z-Axis Leadscrew

Lube Type NLGI#2
 Lube Amount..... Thin Coat
 Lubrication Frequency120 hrs. of Operation

To lubricate Z-axis leadscrew, do these steps:

1. DISCONNECT MACHINE FROM POWER!
2. Lower headstock as far as you can without contacting spindle to table surface.
3. Rotate cover to expose Z-axis leadscrew as shown in Figure 38. Use mineral spirits and a brush to clean as much existing grease and debris off of Z-axis leadscrew as possible. Allow leadscrew to dry.
4. Using a brush, apply NLGI#2 grease to exposed leadscrew threads, then move headstock through its full range of motion several times to disperse grease along full length of leadscrew.

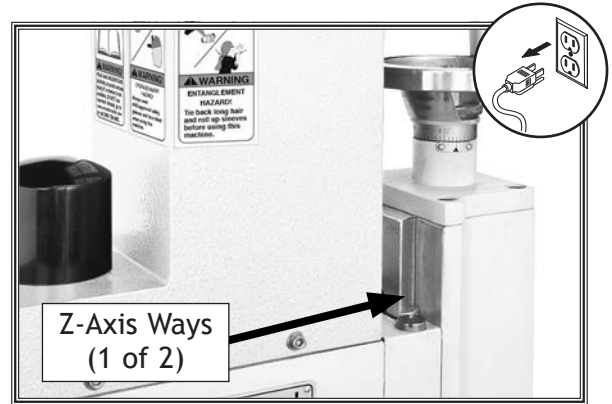

Figure 35. Z-axis way lubrication points.

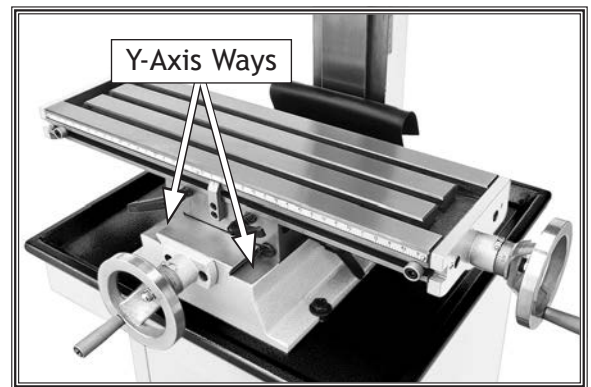

Figure 36. Y-axis way lubrication points.

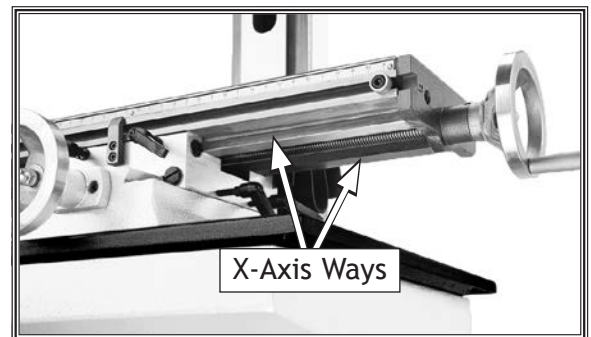

Figure 37. X-axis lubrication points.

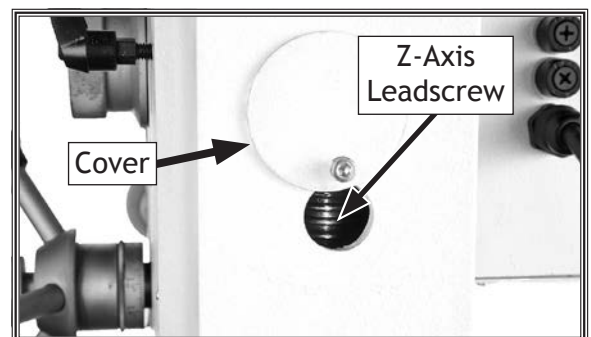

Figure 38. Z-axis leadscrew cover and lubrication point.

MAINTENANCE

Table Leadscrews

Lube TypeModel SB1365 or ISO 68 Equivalent
Lube Amount..... Thin Coat
Lubrication Frequency 40 hrs. of Operation

To lubricate table leadscrews, do these steps:

1. DISCONNECT MACHINE FROM POWER!
2. Using Y-axis handwheel, move table as far forward as possible.
3. Use a 4mm hex wrench to remove rubber way cover, then use mineral spirits and a brush to clean existing grease and debris off of Y-axis leadscrew shown in **Figure 39**. Allow leadscrew to dry.
4. Apply thin coat of ISO 68 machine oil to exposed leadscrew threads, then move table through its full range of cross motion several times to disperse oil along full length of leadscrew.
5. Using X-axis handwheel, move table as far to one side as possible.
6. From beneath table, use mineral spirits and a brush to clean as much of existing grease and debris as possible off of X-axis leadscrew shown in **Figure 40**. Allow leadscrew to dry.
7. Repeat **Step 4** to lubricate X-axis leadscrew.

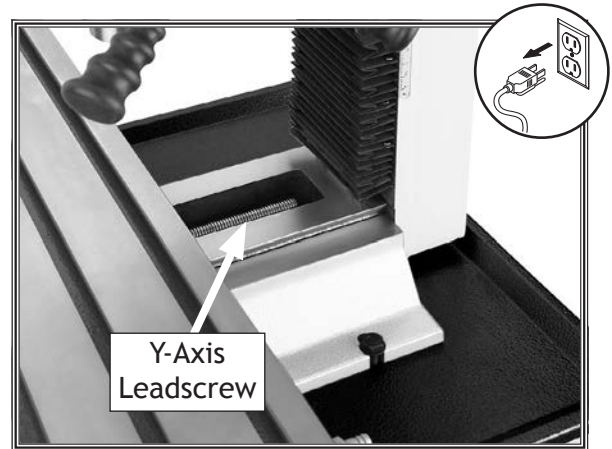

Figure 39. Location of Y-axis leadscrew (way cover removed).



Figure 40. Location of X-axis leadscrew.

Headstock Gears

Lube Type NLGI#2
Lube Amount..... Thin Coat
Lubrication Frequency 90 hrs. of Operation

To lubricate headstock gears, do these steps:

1. Remove cap screw and headstock gear access cover shown in **Figure 41**.
2. Using small brush, apply thin coat of grease to headstock gears.
3. Operate mill/drill in both high and low gear settings to work grease through gears.
4. Re-install access cover and cap screw removed in **Step 1**.

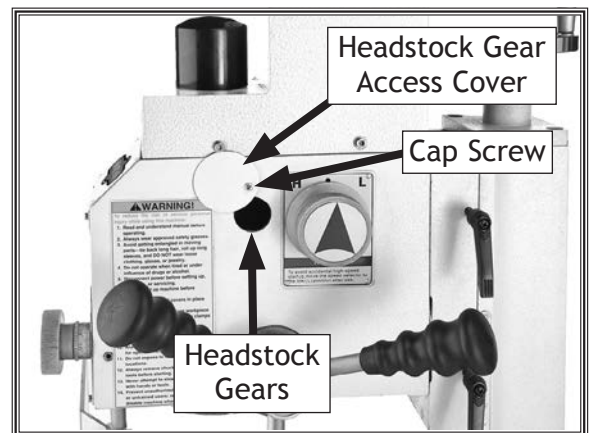

Figure 41. Headstock access cover and cap screw location.

Quill Outside Surface

Lube TypeModel SB1365 or ISO 68 Equivalent
 Lube Amount..... Thin Coat
 Lubrication Frequency8 hrs. of Operation

To lubricate quill, do these steps:

1. Without disturbing grease on quill rack, clean outside smooth surface of quill (see **Figure 42**) with mineral spirits and shop rags.
2. When dry, apply thin coat of lubricant to smooth surface, then move spindle up and down to evenly distribute oil.

Quill Rack

Lube Type NLGI#2
 Lube Amount..... Thin Coat
 Lubrication Frequency 90 hrs. of Operation

To lubricate quill rack, do these steps:

1. Move quill down to gain full access to quill rack (see **Figure 43**).
2. Clean teeth with mineral spirits, shop rags, and brush.
3. When dry, apply thin coat of grease to teeth and raise/lower quill several times to evenly distribute.

Note: Re-apply oil that may have been removed during the cleaning process to the quill surface around the rack.

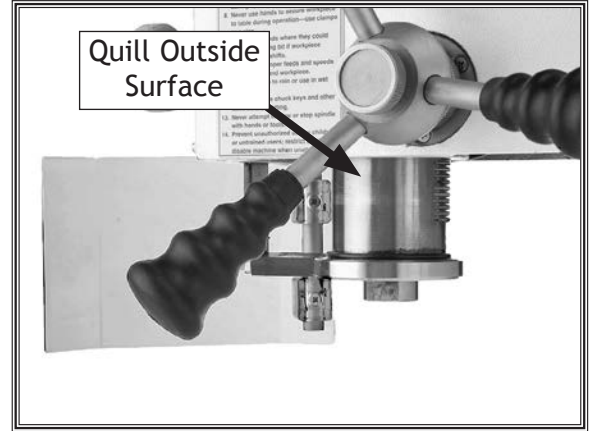

Figure 42. Outside surface of quill.

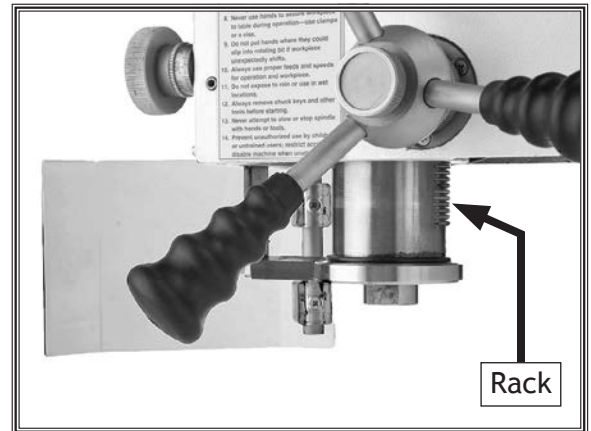

Figure 43. Quill rack location.

Replacing DRO Battery

If the spindle depth DRO stops operating correctly, the 3V lithium cell battery may need replacing.

To replace DRO battery, do these steps:

1. Use a #3 standard screwdriver to remove battery cover (see **Figure 44**).
2. Remove old battery, dispose of it according to state and federal regulations, then replace it with a new one.
3. Replace battery cover.



Figure 44. Battery cover for DRO.

MAINTENANCE

SERVICE

General

This section covers the most common service adjustments or procedures that may need to be made during the life of your machine.

If you require additional machine service not included in this section, please contact Woodstock International Technical Support at (360) 734-3482 or send e-mail to: techsupport@woodstockint.com.

Adjusting Gibs

Tool Needed	Qty
Standard Screwdriver #2.....	1

Gibs are tapered lengths of metal sandwiched between two moving surfaces to control how much friction they have when they slide past one another. Correctly adjusting the gibs is critical to producing accurate milling results.

Tight gibs make table movement more accurate but stiff. Loose gibs make table movement sloppy but easy. The goal of gib adjustment is to remove unnecessary sloppiness without causing the ways to bind.

Tip: Many experienced machinists adjust the gibs until there is just a slight drag in table movement.

Standard screws on each end allow gib adjustment to increase or decrease the friction between the sliding surfaces of the ways.

DISCONNECT MACHINE FROM POWER BEFORE ADJUSTING THE GIBS!

Make sure all table locks are loose. Then, loosen one gib adjustment screw (see **Figure 45**) and tighten the opposing screw the same amount to move the gib, while at the same time using the handwheels to move the table until you feel a slight drag in that path of movement.

⚠ WARNING

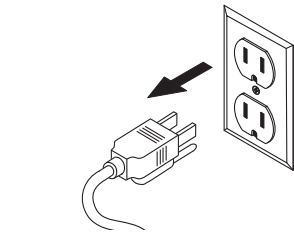

MAKE SURE that your machine is unplugged during all service procedures! If this warning is ignored, serious personal injury may occur.

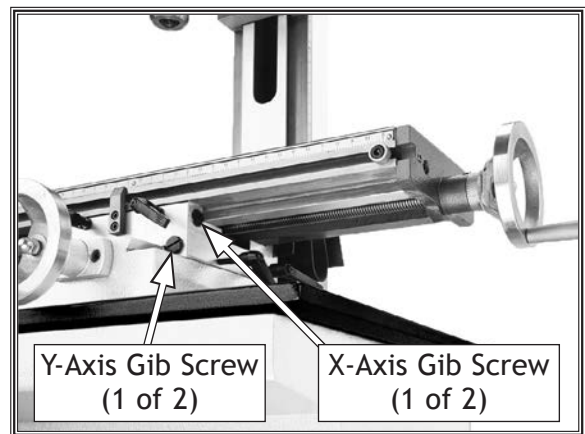

Figure 45. Location of gib screws.

Adjusting Leadscrew Backlash

Leadscrew backlash is the amount of free-play movement in the leadscrew (when changing the direction of rotation) before the attached device begins to move.

Leadscrews must have a certain amount of backlash, but over time, this will increase with normal wear. Generally, 0.003"-0.006" leadscrew backlash is acceptable to ensure smooth movement and reduce the risk of premature thread wear.

The X- and Y-axis leadscrew backlash is adjusted by using a long 5mm hex wrench to tighten/loosen the cap screw on the leadscrew nut. This adjusts the force the split leadscrew nut exerts on the leadscrew threads.

The X-axis leadscrew nut shown in **Figure 46** is accessed from underneath the left side of the table.

The Y-axis leadscrew nut is similar and is accessed from underneath the machine base.

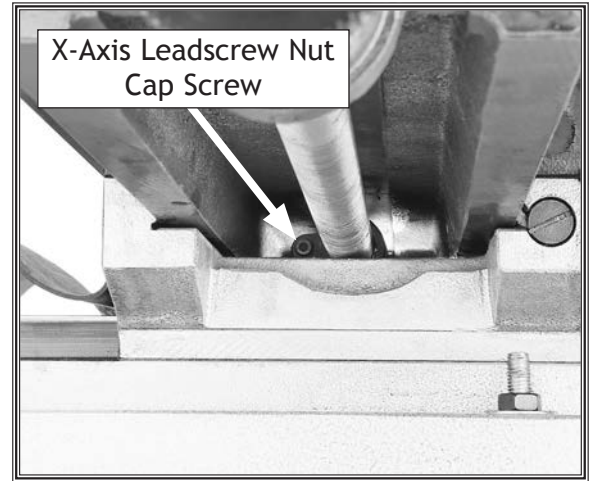

Figure 46. Example of X-axis leadscrew nut cap screw for adjusting backlash.

Brush Replacement

This mill/drill is equipped with a universal motor that uses two carbon brushes to transmit electrical current inside the motor. These brushes are considered to be regular "wear items" or "consumables" that will need to be replaced during the life of the motor. The frequency of required replacement is often related to how much the motor is used and how hard it is pushed.

Replace the carbon brushes in pairs (part number: XM1116202) when the motor no longer reaches full power, or when the brushes measure less than 1/4" long (new brushes are 5/8" long).

Tools Needed:	Qty
Hex Wrench 3mm	1
Standard Screwdriver #2.....	1

To inspect and replace motor brushes, do these steps:

1. DISCONNECT MACHINE FROM POWER!
2. Remove motor cover by removing cap screws (see Figure 47).
3. Unscrew one of the brush caps (see Figure 48).
4. Remove old brush assembly. If brush is worn down to less than 1/4", then replace it with a new one. Otherwise re-install old brush (see Figure 49).
5. Replace brush cap to secure brush.
6. Repeat Steps 3-5 for second brush assembly on other side of motor.
7. Replace motor cover.

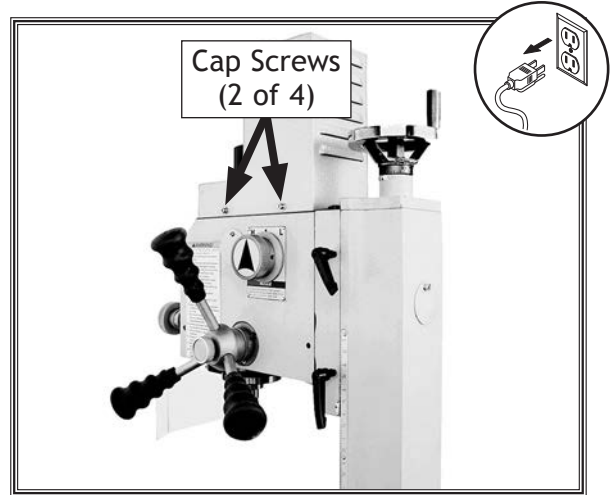

Figure 47. Location of motor cover cap screws.



Figure 48. Removing motor brush cap.



Figure 49. Inserting new motor brush.

Troubleshooting

The following troubleshooting tables cover common problems that may occur with this machine. If you need replacement parts or additional troubleshooting help, contact our Technical Support.

Note: Before contacting Tech Support, find the machine serial number and manufacture date, and if available, your original purchase receipt. This information is required to properly assist you.

Motor & Electrical

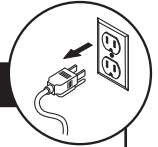

PROBLEM	POSSIBLE CAUSE	CORRECTIVE ACTION
Machine does not start or a breaker trips.	<ol style="list-style-type: none"> 1. Blown fuse in machine. 2. Chuck guard open. 3. Incorrect power supply voltage or circuit size. 4. Plug/receptacle at fault/wired incorrectly. 5. Power supply circuit breaker tripped or fuse blown. 6. Motor wires connected incorrectly. 7. Wiring open/has high resistance. 8. Motor brushes at fault. 9. Chuck guard safety switch at fault. 10. Circuit board at fault. 11. Motor at fault. 12. Potentiometer/variable-speed dial at fault. 	<ol style="list-style-type: none"> 1. Replace fuse/ensure no shorts. 2. Close guard. 3. Ensure power supply voltage and circuit size (Page 41). 4. Test for good contacts; correct wiring (Page 41). 5. Ensure circuit is sized correctly and free of shorts. Reset circuit breaker or replace fuse (Page 41). 6. Correct motor wiring connections (Page 41). 7. Check/fix broken, disconnected, corroded wires; repair/replace as necessary (Page 42). 8. Remove/replace brushes (Page 37). 9. Replace safety switch (Page 41). 10. Test/replace (Page 42). 11. Test/repair/replace (Page 41). 12. Test/replace (Page 41).
Machine stalls or is overloaded.	<ol style="list-style-type: none"> 1. Feed rate/cutting speed too fast. 2. Wrong cutter type. 3. Machine undersized for task or tooling incorrect for task. 4. Motor wired incorrectly. 5. Motor bearings at fault. 6. Motor overheated. 7. Motor at fault. 	<ol style="list-style-type: none"> 1. Decrease feed rate/cutting speed. 2. Use correct cutter for task. 3. Use correct cutter/bit; reduce spindle RPM; use coolant fluid if possible. 4. Wire motor correctly (Page 41). 5. Test/repair/replace. 6. Clean motor/let cool/reduce workload. 7. Test/repair/replace.
Machine has vibration or noisy operation.	<ol style="list-style-type: none"> 1. Motor or machine component loose. 2. Machine incorrectly mounted or sits unevenly. 3. Motor fan rubbing on fan cover. 4. Workpiece not secure. 5. Excessive depth of cut. 6. Cutter/tooling loose. 7. Cutter dull or at fault. 8. Bit is chattering. 9. Motor bearings at fault. 	<ol style="list-style-type: none"> 1. Inspect/replace damaged bolts/nuts, and retighten with blue thread-locking fluid. 2. Tighten/replace mounting bolts in bench/stand; relocate/shim machine (Page 18). 3. Fix/replace dented fan cover; replace loose/damaged fan. 4. Properly clamp workpiece on table or in vise. 5. Decrease depth of cut. 6. Make sure tooling is properly secured. 7. Replace/resharpen cutter. 8. Replace/sharpen bit; index bit to workpiece; use appropriate feed rate and cutting RPM. 9. Test by rotating shaft; rotational grinding/loose shaft requires bearing replacement.

Operation

PROBLEM	POSSIBLE CAUSE	CORRECTIVE ACTION
Tool loose in spindle.	<ol style="list-style-type: none"> 1. Cutting tool not fully drawn up into spindle taper. 2. Debris on cutting tool or in spindle taper. 3. Taking too big of cut. 	<ol style="list-style-type: none"> 1. Tighten drawbar (do not overtighten) (Page 27). 2. Clean collet and spindle taper. 3. Lessen depth of cut and allow chips to clear.
Breaking tools or cutters.	<ol style="list-style-type: none"> 1. Spindle speed/feed rate too fast for depth of cut, cutting tool size, or workpiece material. 2. Cutting tool too small. 3. Improper or no cutting lubricant/ cutting tool getting too hot. 4. Taking too big of a cut. 5. Spindle extended too far down. 	<ol style="list-style-type: none"> 1. Reduce spindle speed (Page 28); reduce feed rate; take lighter cut. 2. Use larger cutting tool and slower feed rate. 3. Use proper lubricant for operation. 4. Lessen depth of cut and allow chips to clear. 5. Fully retract spindle and lower headstock. This increases rigidity.
Workpiece vibrates or chatters during operation.	<ol style="list-style-type: none"> 1. Table locks not tight. 2. Workpiece not secure. 3. Spindle speed/feed rate too fast. 4. Spindle extended too far down. 	<ol style="list-style-type: none"> 1. Tighten table locks (Page 25). 2. Properly clamp workpiece on table or in vise. 3. Reduce spindle speed (Page 28); reduce feed rate. 4. Fully retract spindle and lower headstock. This increases rigidity.
Table is hard to move.	<ol style="list-style-type: none"> 1. Table locks tightened down. 2. Chips loaded up on ways. 3. Ways are dry and need lubrication. 4. Table limit stops interfering. 5. Gibs too tight. 	<ol style="list-style-type: none"> 1. Release table locks (Page 25). 2. Frequently clean away chips that load up during milling operations. 3. Lubricate ways (Page 32). 4. Adjust table limit stops out of the way (Page 25). 5. Adjust gibs (see Page 35).
Bad surface finish.	<ol style="list-style-type: none"> 1. Spindle speed/feed rate too fast. 2. Dull/incorrect cutting tool. 3. Wrong rotation direction of cutting tool. 4. Workpiece not secure. 5. Spindle extended too far down during or at beginning of operation. 	<ol style="list-style-type: none"> 1. Reduce spindle speed (Page 28); reduce feed rate. 2. Sharpen/replace cutting tool; select better tool for operation. 3. Check for proper direction of cutting tool rotation. 4. Properly clamp workpiece on table or in vise. 5. Fully retract spindle and lower headstock. This increases rigidity.
Threads not smooth.	<ol style="list-style-type: none"> 1. Cutting edge chipped on cutting tool. 2. Cutting tool not centered. 3. Chip packing. 4. Galling (adhesion between surfaces). 	<ol style="list-style-type: none"> 1. Replace cutting tool. 2. Center cutting tool. 3. Use spiral point/spiral fluted taps; reduce number of flutes to provide extra chip room. 4. Use proper coolant; reduce tapping speed.
Cutting results not square.	<ol style="list-style-type: none"> 1. Table travel inconsistent. 	<ol style="list-style-type: none"> 1. Adjust gibs (Page 35).

Operation

PROBLEM	POSSIBLE CAUSE	CORRECTIVE ACTION
Spindle speed readout does not display reading.	<ol style="list-style-type: none"> 1. Shorted/disconnected wiring/plugs. 2. Spindle speed sensor has gone bad. 3. Spacing between sensor and scale incorrect. 	<ol style="list-style-type: none"> 1. Inspect circuit boards, sensors, plugs, and wiring connections. Repair/replace as necessary. 2. Test/replace as necessary. 3. Adjust spacing between sensor and scale.

Digital Readout Units (DRO)

PROBLEM	POSSIBLE CAUSE	CORRECTIVE ACTION
X/Y/Z-Axis DRO or spindle depth DRO do not give reading.	<ol style="list-style-type: none"> 3. Shorted/disconnected wiring/plugs. 1. X/Y/Z-Axis DRO is not plugged in. 2. Spindle depth DRO battery is dead. 	<ol style="list-style-type: none"> 3. Inspect sensors, plugs, and wiring connections. Replace/repair as necessary. 1. Connect DRO to power (Page 26). 2. Replace battery (Page 34).
X/Y/Z-Axis DRO reading is incorrect.	<ol style="list-style-type: none"> 1. Spacing between sensor and scale is incorrect. 2. Initial reading is incorrect. 3. Sensor has gone bad. 	<ol style="list-style-type: none"> 1. Adjust spacing between sensor and scale. 2. Zero/reset DRO at beginning point (Page 26). 3. Test/replace sensor as necessary.

Electrical Safety Instructions

These pages are current at the time of printing. However, in the spirit of improvement, we may make changes to the electrical systems of future machines. Compare the manufacture date of your machine to the one stated in this manual, and study this section carefully.

If there are differences between your machine and what is shown in this section, call Technical Support at (360) 734-3482 for assistance BEFORE making any changes to the wiring on your machine. An updated wiring diagram may be available. **Note:** Please gather the serial number and manufacture date of your machine before calling. This information can be found on the main machine label.

WARNING

SHOCK HAZARD. Working on wiring that is connected to a power source is extremely dangerous. Touching electrified parts will result in personal injury including but not limited to severe burns, electrocution, or death. Disconnect the power from the machine before servicing electrical components!

QUALIFIED ELECTRICIAN. Due to the inherent hazards of electricity, only a qualified electrician should perform wiring tasks on this machine. If you are not a qualified electrician, get help from one before attempting any kind of wiring job.

WIRE CONNECTIONS. All connections must be tight to prevent wires from loosening during machine operation. Double-check all wires disconnected or connected during any wiring task to ensure tight connections.

WIRE/COMPONENT DAMAGE. Damaged wires or components increase the risk of serious personal injury, fire, or machine damage. If you notice that any wires or components are damaged while performing a wiring task, replace those wires or components before completing the task.

MODIFICATIONS. Using aftermarket parts or modifying the wiring beyond what is shown in the diagram may lead to unpredictable results, including serious injury or fire.

MOTOR WIRING. The motor wiring shown in these diagrams is current at the time of printing, but it may not match your machine. Always use the wiring diagram inside the motor junction box.

CAPACITORS/INVERTERS. Some capacitors and power inverters store an electrical charge for up to 10 minutes after being disconnected from the power source. To reduce the risk of being shocked, wait at least this long before working on capacitors.

CIRCUIT REQUIREMENTS. You MUST follow the requirements at the beginning of this manual when connecting your machine to a power source.

EXPERIENCING DIFFICULTIES. If you are experiencing difficulties understanding the information included in this section, contact our Technical Support at (360) 734-3482.

NOTICE

The photos and diagrams included in this section are best viewed in color. You can view these pages in color at www.shopfox.biz.

WIRING DIAGRAM COLOR KEY

BLACK	BLUE	YELLOW	LIGHT BLUE
WHITE	BROWN	YELLOW GREEN	BLUE WHITE
GREEN	GRAY	PURPLE	TUR-QUOISE
RED	ORANGE	PINK	

M1116 Electrical Components

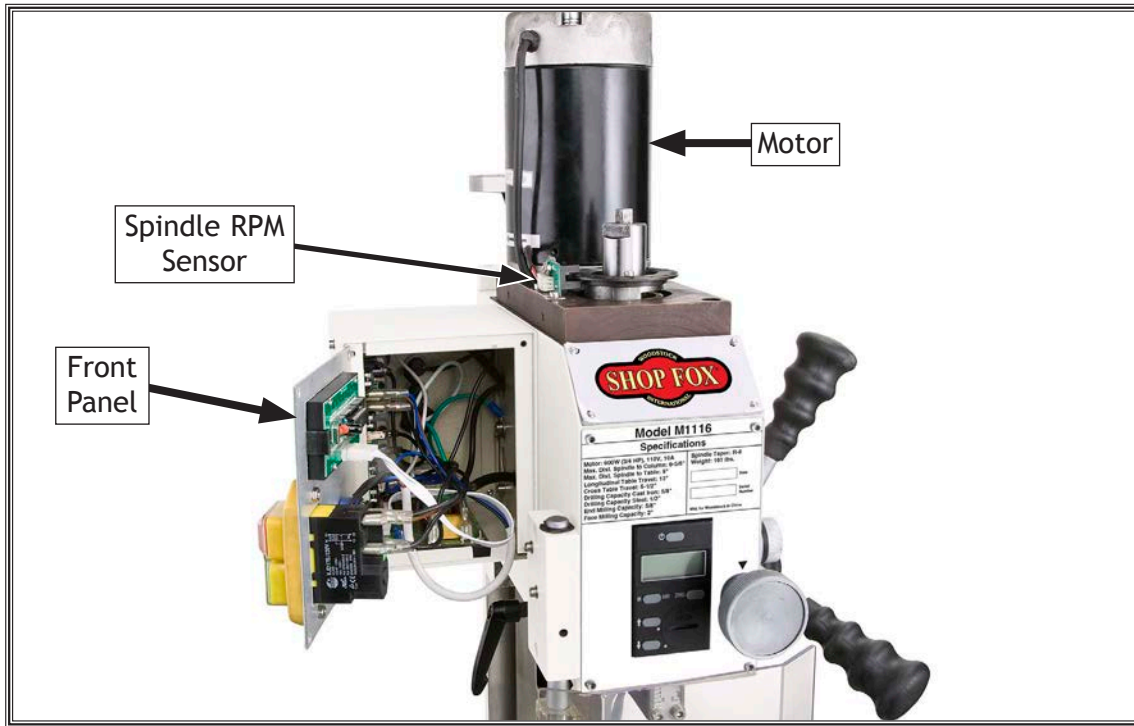

Figure 50. Wiring overview.

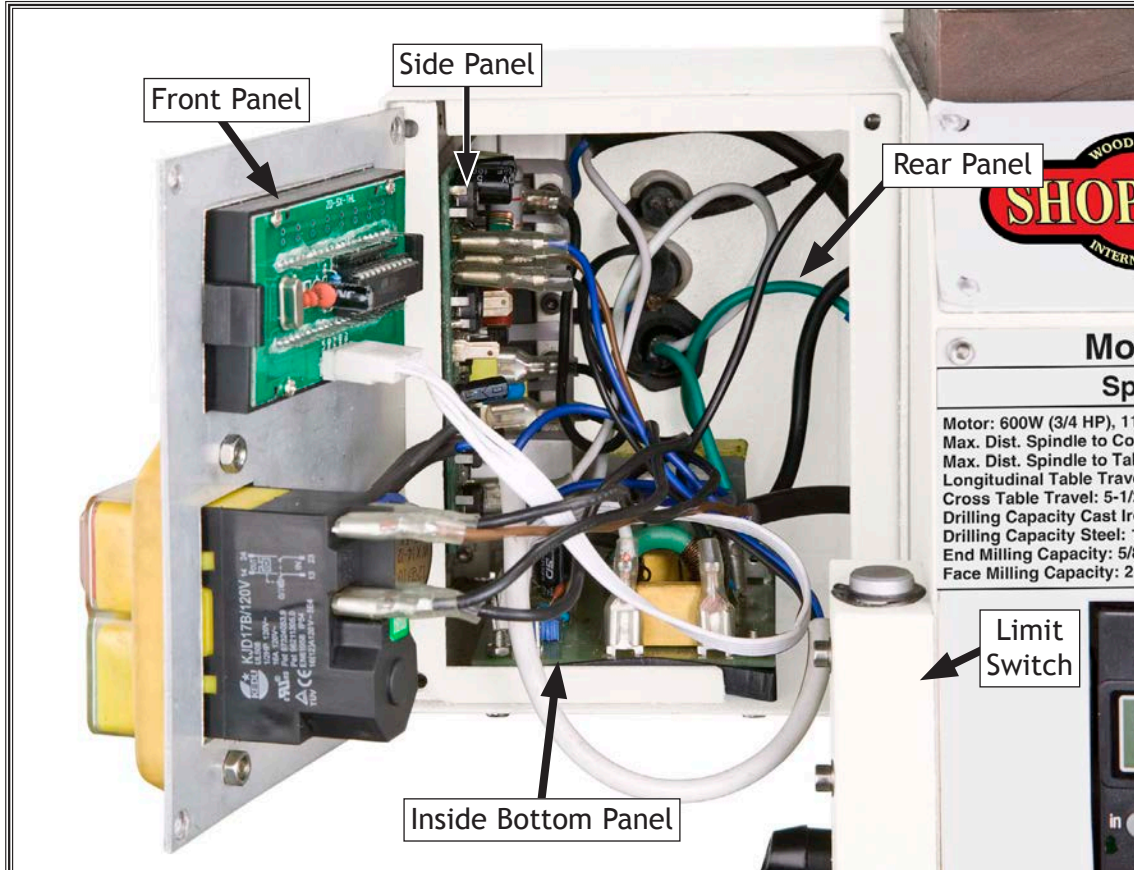
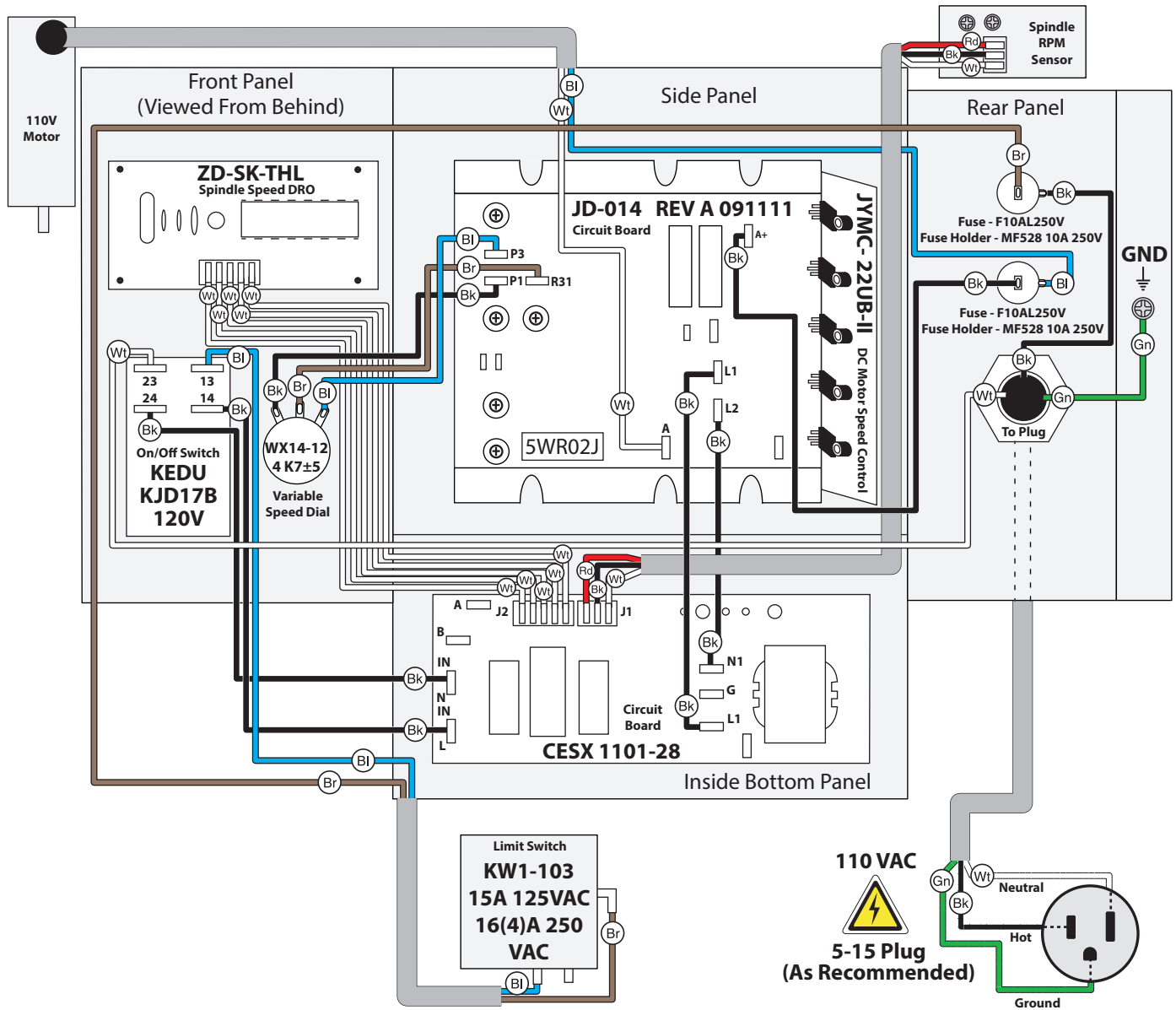

Figure 51. Control panel wiring overview.

M1116 Wiring Diagram



NOTICE

This motor wiring diagram is current at the time of printing; however, always use the diagram on the inside of the junction box cover when rewiring your motor!

SERVICE

PARTS

Column

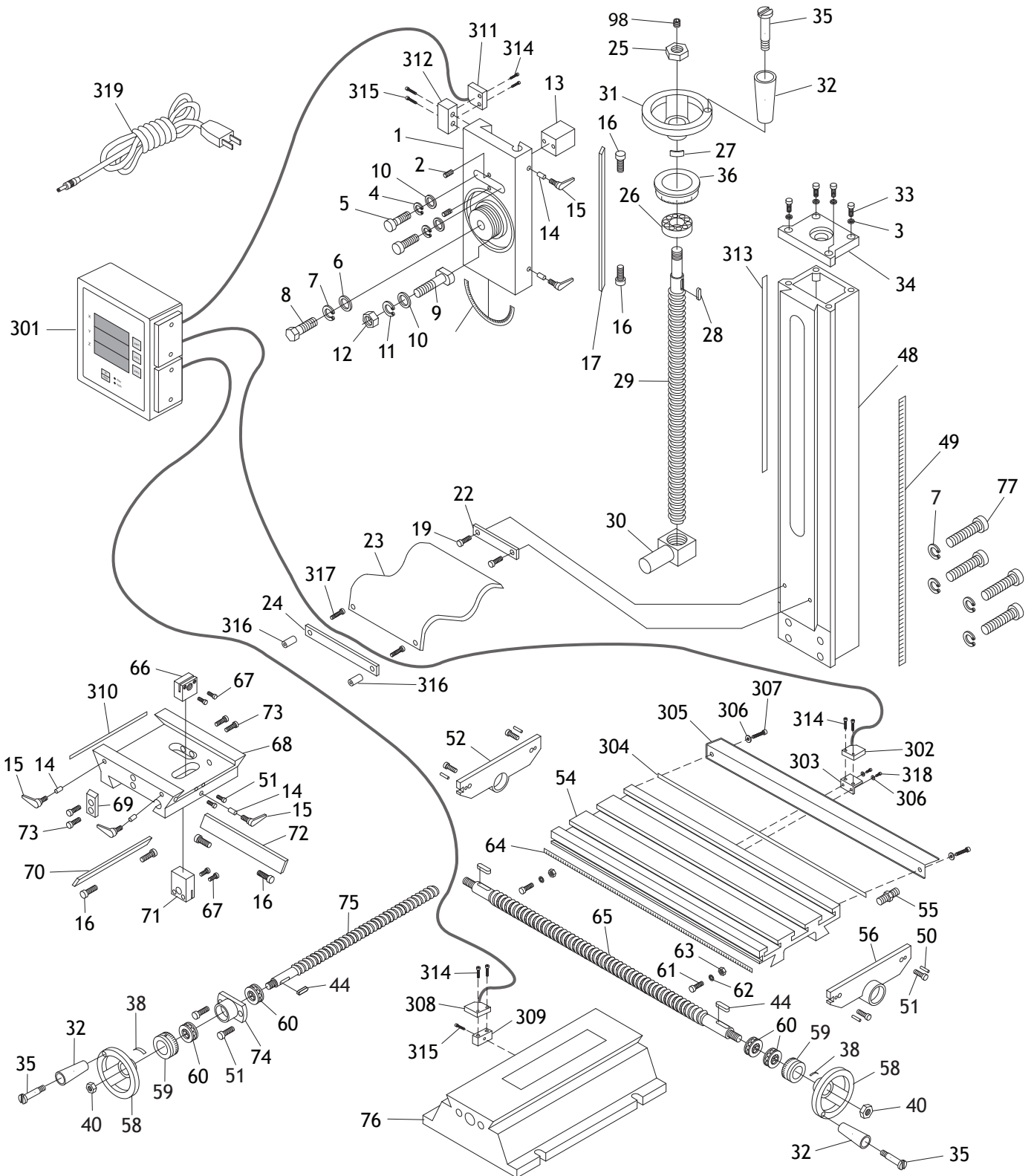

PARTS

Column Parts List

REF PART #	DESCRIPTION	REF PART #	DESCRIPTION		
1	XM1116001	Z-AXIS SLIDE	55	XM1116055	COOLANT HOSE FITTING
2	XM1116002	SET SCREW M6-1 X 16	56	XM1116056	X-AXIS LEADSCREW BRACKET (RH)
3	XM1116003	FLAT WASHER 6MM	57	XM1116057	HANDLE W/OUT SHAFT 15 X 50, 8D
4	XM1116004	LOCK WASHER 8MM	58	XM1116058	HANDWHEEL TYPE-4 100D X 10B-K X M6-1
5	XM1116005	CAP SCREW M8-1.25 X 25	59	XM1116059	TABLE GRADUATED DIAL
6	XM1116006	FLAT WASHER 12MM	60	XM1116060	THRUST BEARING 51100
7	XM1116007	LOCK WASHER 12MM	61	XM1116061	CAP SCREW M6-1 X 10
8	XM1116008	CAP SCREW M12-1.75 X 40	62	XM1116062	LIMIT STOP
9	XM1116009	T-BOLT M8-1.25 X 60	63	XM1116063	T-NUT M6-1
10	XM1116010	FLAT WASHER 8MM	64	XM1116064	X-AXIS SCALE
11	XM1116011	LOCK WASHER 8MM	65	XM1116065	X-AXIS LEADSCREW
12	XM1116012	HEX NUT M8-1.25	66	XM1116066	X-AXIS LEADSCREW NUT
13	XM1116013	SLIDE ALIGNMENT BLOCK	67	XM1116067	CAP SCREW M4-.7 X 20
14	XM1116014	LOCK PLUNGER, BRASS	68	XM1116068	SADDLE
15	XM1116015	ADJUSTABLE HANDLE 50L, M6-1 X 16	69	XM1116069	TABLE STOP BLOCK
16	XM1116016	GIB ADJUSTMENT SCREW M6-1 X 25	70	XM1116070	Y-AXIS GIB
17	XM1116017	Z-AXIS GIB	71	XM1116071	Y-AXIS LEADSCREW NUT
18	XM1116018	HEADSTOCK ANGLE SCALE	72	XM1116072	X-AXIS GIB
19	XM1116019	CAP SCREW M5-.8 X 10	73	XM1116073	CAP SCREW M6-1 X 25
22	XM1116022	Z-AXIS WAY COVER BRACKET	74	XM1116074	X-AXIS BEARING HOUSING
23	XM1116023	Y-AXIS WAY COVER	75	XM1116075	X-AXIS LEADSCREW
24	XM1116024	Y-AXIS WAY COVER BRACKET	76	XM1116076	BASE
25	XM1116025	HEX NUT M10-1.5 TALL	77	XM1116077	CAP SCREW M12-1.75 X 90
26	XM1116026	THRUST BEARING 51200	98	XM1116098	SET SCREW M10-1.5 X 8
27	XM1116027	INDICATOR PLATE	301	XM1116301	DRO DISPLAY UNIT
28	XM1116028	MACHINE KEY 4 X 4 X 16	302	XM1116302	X-AXIS DRO SENSOR
29	XM1116029	Z-AXIS LEADSCREW	303	XM1116303	X-AXIS SENSOR MOUNTING BRACKET
30	XM1116030	Z-AXIS LEADSCREW NUT	304	XM1116304	X-AXIS METALLIC STRIP 10 X 480MM
31	XM1116031	HANDWHEEL TYPE-4 100D X 10B-K X M6-1	305	XM1116305	ALUMINUM BRACKET 30 X 480MM
32	XM1116032	HANDLE W/OUT SHAFT 15 X 50, 8D	306	XM1116306	FLAT WASHER 4MM
33	XM1116033	CAP SCREW M6-1 X 14	307	XM1116307	CAP SCREW M4-.7 X 8
34	XM1116034	COLUMN TOP COVER	308	XM1116308	Y-AXIS DRO SENSOR
35	XM1116035	SHOULDER SCREW M6-1 X 60, 8 X 45	309	XM1116309	Y-AXIS SENSOR MOUNTING BLOCK
36	XM1116036	Z-AXIS GRADUATED DIAL	310	XM1116310	Y-AXIS METALLIC STRIP 10 X 150MM
38	XM1116038	HANDWHEEL CURVED PLATE SPRING	311	XM1116311	Z-AXIS DRO SENSOR
40	XM1116040	HEX NUT M8-1.25	312	XM1116312	Z-AXIS SENSOR MOUNTING BLOCK
44	XM1116044	MACHINE KEY 4 X 4 X 12	313	XM1116313	Z-AXIS METALLIC STRIP 10 X 390MM
48	XM1116048	COLUMN	314	XM1116314	CAP SCREW M3-.5 X 16
49	XM1116049	Z-AXIS SCALE	315	XM1116315	CAP SCREW M4-.7 X 16
50	XM1116050	THREADED SLEEVE M6-1 X 16	316	XM1116316	STEEL SLEEVE 5 X 18 X 33L
51	XM1116051	CAP SCREW M6-1 X 14	317	XM1116317	CAP SCREW M5-.8 X 50
52	XM1116052	X-AXIS LEADSCREW BRACKET (LH)	318	XM1116318	CAP SCREW M4-.7 X 8
54	XM1116054	TABLE	319	XM1116319	DRO POWER CORD 2W 18G 72" 1-15P

Control Panel

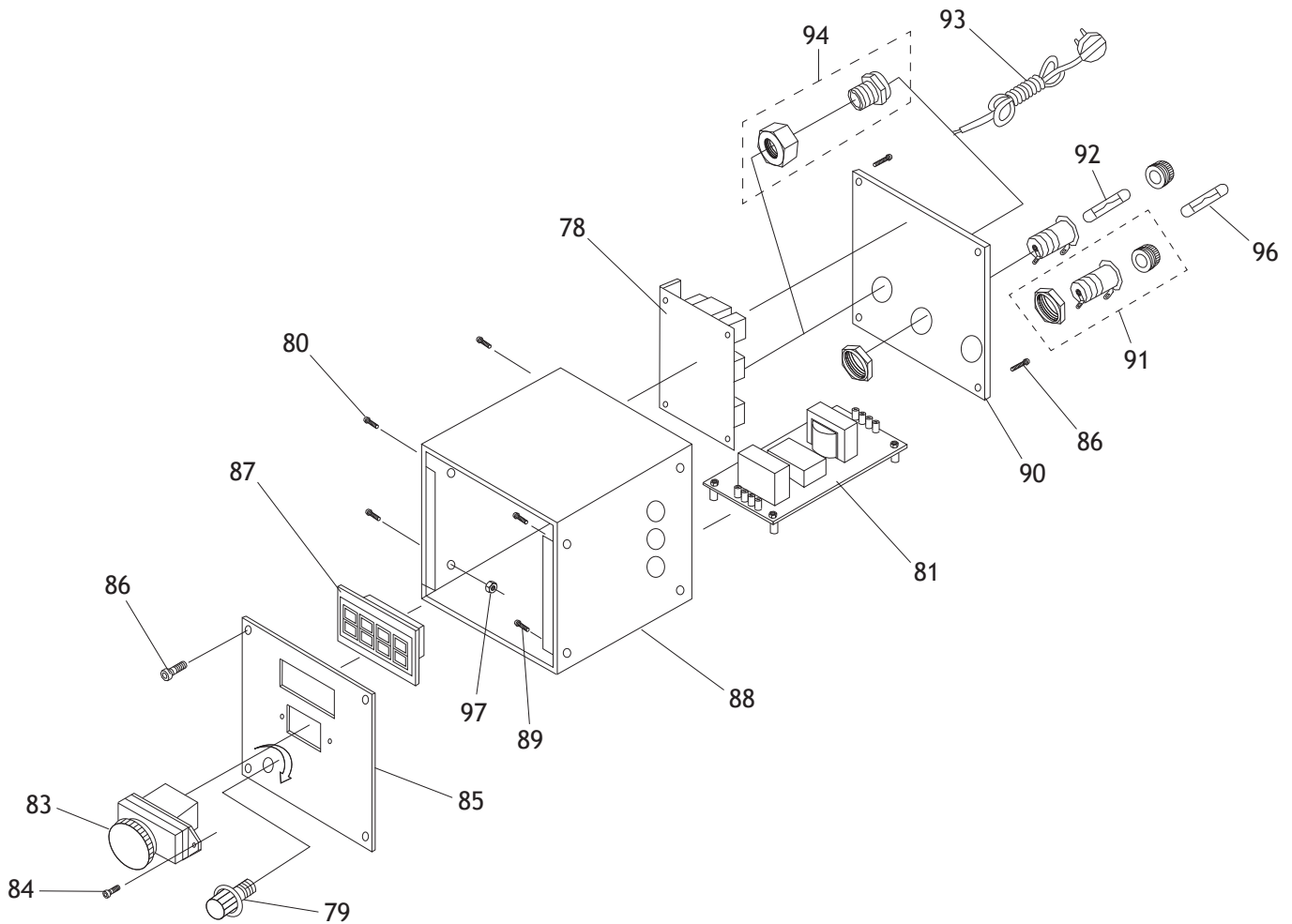

REF PART #	DESCRIPTION
78	XM1116078 CIRCUIT BOARD JD-014 5WR02J
79	XM1116079 SPINDLE POTENTIOMETER WX14-12
80	XM1116080 CAP SCREW M3-.5 X 16
81	XM1116081 CIRCUIT BOARD CESX 1101-28
83	XM1116083 ON/OFF SWITCH KEDU KJD-17B/120V
84	XM1116084 CAP SCREW M4-.7 X 10
85	XM1116085 CONTROL PANEL PLATE
86	XM1116086 CAP SCREW M4-.7 X 6
87	XM1116087 RPM DIGITAL DISPLAY ZD-SX-THL

REF PART #	DESCRIPTION
88	XM1116088 ELECTRICAL BOX
89	XM1116089 CAP SCREW M5-.8 X 8
90	XM1116090 ELECTRICAL BOX REAR COVER
91	XM1116091 FUSE HOLDER
92	XM1116092 FUSE 15A 250V FAST-ACTING, GLASS
93	XM1116093 POWER CORD 16G 3W 72" 5-15P
94	XM1116094 STRAIN RELIEF M20 X 1.5 TYPE-3
96	XM1116096 FUSE 10A 250V FAST-ACTING, GLASS
97	XM1116097 HEX NUT M3-.5

Headstock

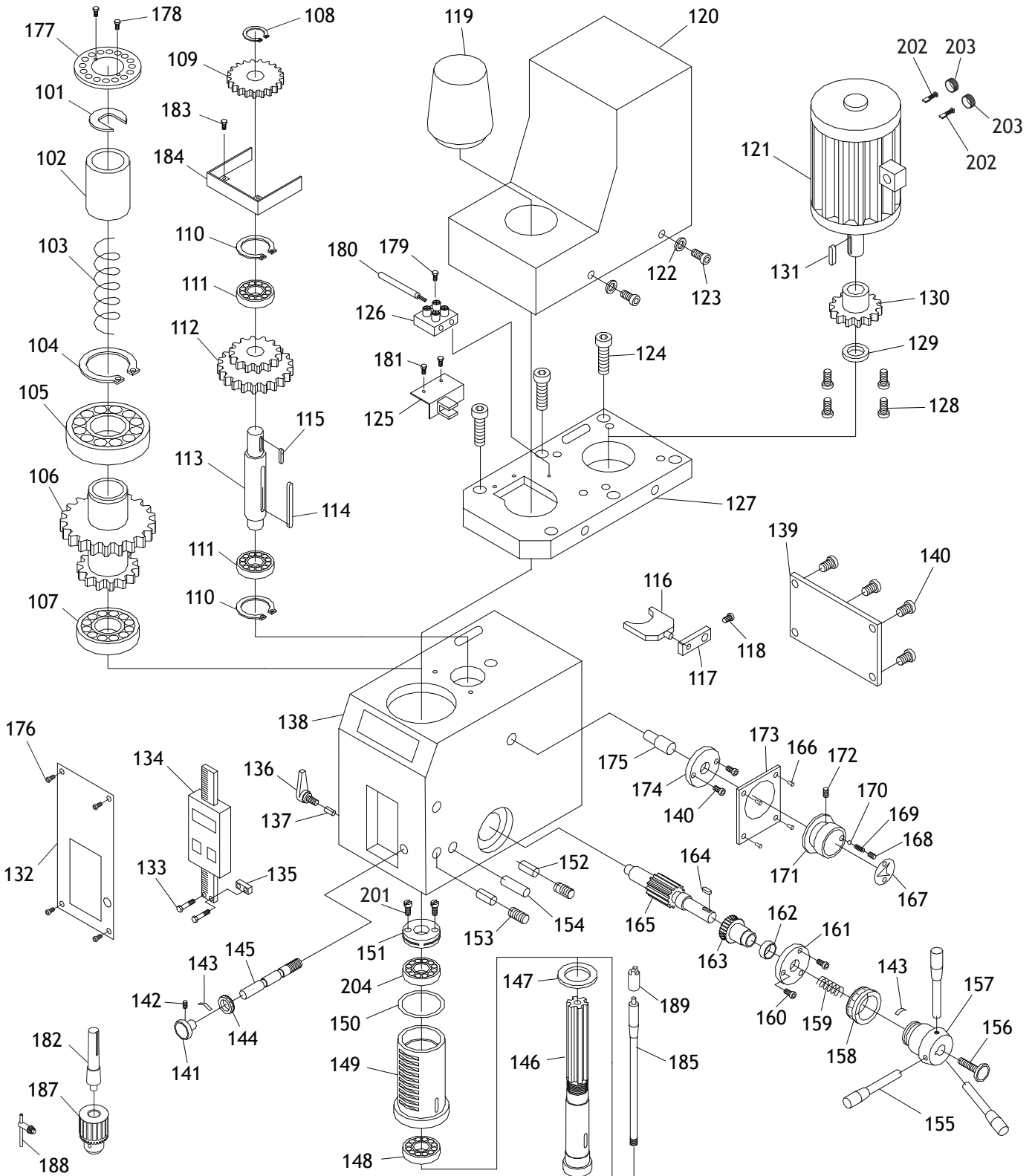

Headstock Parts List

REF PART #	DESCRIPTION	
101	XM1116101	QUILL RETAINING CLIP
102	XM1116102	BUSHING
103	XM1116103	COMPRESSION SPRING 2.5 X 29 X 100
104	XM1116104	EXT RETAINING RING 45MM
105	XM1116105	BALL BEARING 6209ZZ
106	XM1116106	COMBO GEAR 60/70T
107	XM1116107	ANG CONTACT BEARING 7007-2RSD
108	XM1116108	EXT RETAINING RING 15MM
109	XM1116109	GEAR 37T
110	XM1116110	EXT RETAINING RING 32MM
111	XM1116111	BALL BEARING 6002ZZ
112	XM1116112	COMBO GEAR 42/62T
113	XM1116113	SHAFT
114	XM1116114	MACHINE KEY 5 X 5 X 50
115	XM1116115	MACHINE KEY 5 X 5 X 12
116	XM1116116	FORK
117	XM1116117	FORK ARM
118	XM1116118	CAP SCREW M5-.8 X 8
119	XM1116119	DRAWBAR CAP
120	XM1116120	MOTOR COVER
121	XM1116121	MOTOR 600W 110VDC
122	XM1116122	FLAT WASHER 4MM
123	XM1116123	CAP SCREW M4-.7 X 8
124	XM1116124	CAP SCREW M6-1 X 14
125	XM1116125	L-BRACKET
126	XM1116126	SPEED SENSOR
127	XM1116127	MOTOR MOUNT
128	XM1116128	CAP SCREW M5-.8 X 12
129	XM1116129	MOTOR GEAR RING
130	XM1116130	GEAR 25T
131	XM1116131	MACHINE KEY 4 X 4 X 6
132	XM1116132	HEADSTOCK FRONT PANEL PLATE
133	XM1116133	HEX BOLT M3-.5 X 6
134	XM1116134	Z-AXIS DRO ASSEMBLY
135	XM1116135	DRO SLIDE MOUNT
136	XM1116136	ADJUSTABLE HANDLE 50L, M6-1 X 16
137	XM1116137	LOCK PLUNGER, BRASS
138	XM1116138	HEADSTOCK CASTING
139	XM1116139	HEADSTOCK REAR COVER
140	XM1116140	CAP SCREW M4-.7 X 8
141	XM1116141	FINE DOWNFEED KNOB 12 X 26 X 45D
142	XM1116142	SET SCREW M5-.8 X 6
143	XM1116143	SPRING PIECE
144	XM1116144	FINE DOWNFEED GRADUATED DIAL
145	XM1116145	WORM SHAFT
146	XM1116146	SPINDLE R8

REF PART #	DESCRIPTION	
147	XM1116147	QUILL SEAL, RUBBER (LOWER)
148	XM1116148	TAPERED ROLLER BEARING 32005
149	XM1116149	QUILL
150	XM1116150	QUILL SEAL, RUBBER (UPPER)
151	XM1116151	PRELOAD ADJUSTER NUT
152	XM1116152	DOWEL PIN 4 X 20, BRASS
153	XM1116153	SET SCREW M5-.8 X 12
154	XM1116154	DOWEL PIN 6 X 30
155	XM1116155	COARSE DOWNFEED LEVER M10-1.5 X 14
156	XM1116156	KNOB BOLT M8-1.25 X 30
157	XM1116157	COARSE DOWNFEED HUB
158	XM1116158	COARSE DOWNFEED GRADUATED DIAL
159	XM1116159	COMPRESSION SPRING 1.2 X 12 X 2.5
160	XM1116160	CAP SCREW M4-.7 X 40
161	XM1116161	FLANGE
162	XM1116162	BUSHING
163	XM1116163	WORM GEAR
164	XM1116164	MACHINE KEY 4 X 4 X 12
165	XM1116165	GEAR SHAFT 16T
166	XM1116166	RIVET 2 X 5MM NAMEPLATE, STEEL
167	XM1116167	HI/LO GEAR INDICATOR PLATE
168	XM1116168	SET SCREW M8-1.25 X 8
169	XM1116169	COMPRESSION SPRING 0.8 X 5 X 25
170	XM1116170	STEEL BALL 6.5MM
171	XM1116171	HI/LO GEAR KNOB 50D
172	XM1116172	SET SCREW M5-.8 X 16
173	XM1116173	SPEED KNOB PLATE
174	XM1116174	FORK SHAFT FLANGE
175	XM1116175	FORK SHAFT
176	XM1116176	CAP SCREW M3-.5 X 6
177	XM1116177	SPINDLE RING 16MM
178	XM1116178	CAP SCREW M3-.5 X 6
179	XM1116179	HEX BOLT M3-.5 X 12
180	XM1116180	SPEED SENSOR CORD
181	XM1116181	HEX BOLT M3-.5 X 6
182	XM1116182	DRILL CHUCK ARBOR R8 X B16
183	XM1116183	CAP SCREW M3-.5 X 6
184	XM1116184	GEAR GUARD
185	XM1116185	DRAWBAR 7/16-20 X 9-7/8
187	XM1116187	DRILL CHUCK B16 3-16MM
188	XM1116188	DRILL CHUCK KEY 1/4" STD 11T SD-3/4"
189	XM1116189	DRAWBAR RETAINER CAP
201	XM1116201	PRELOAD ADJUSTER SCREW M5-.8 X 10
202	XM1116202	MOTOR CARBON BRUSH
203	XM1116203	MOTOR CARBON BRUSH CAP 1-PC
204	XM1116204	TAPERED ROLLER BEARING 32005

Tools & Chip Guard

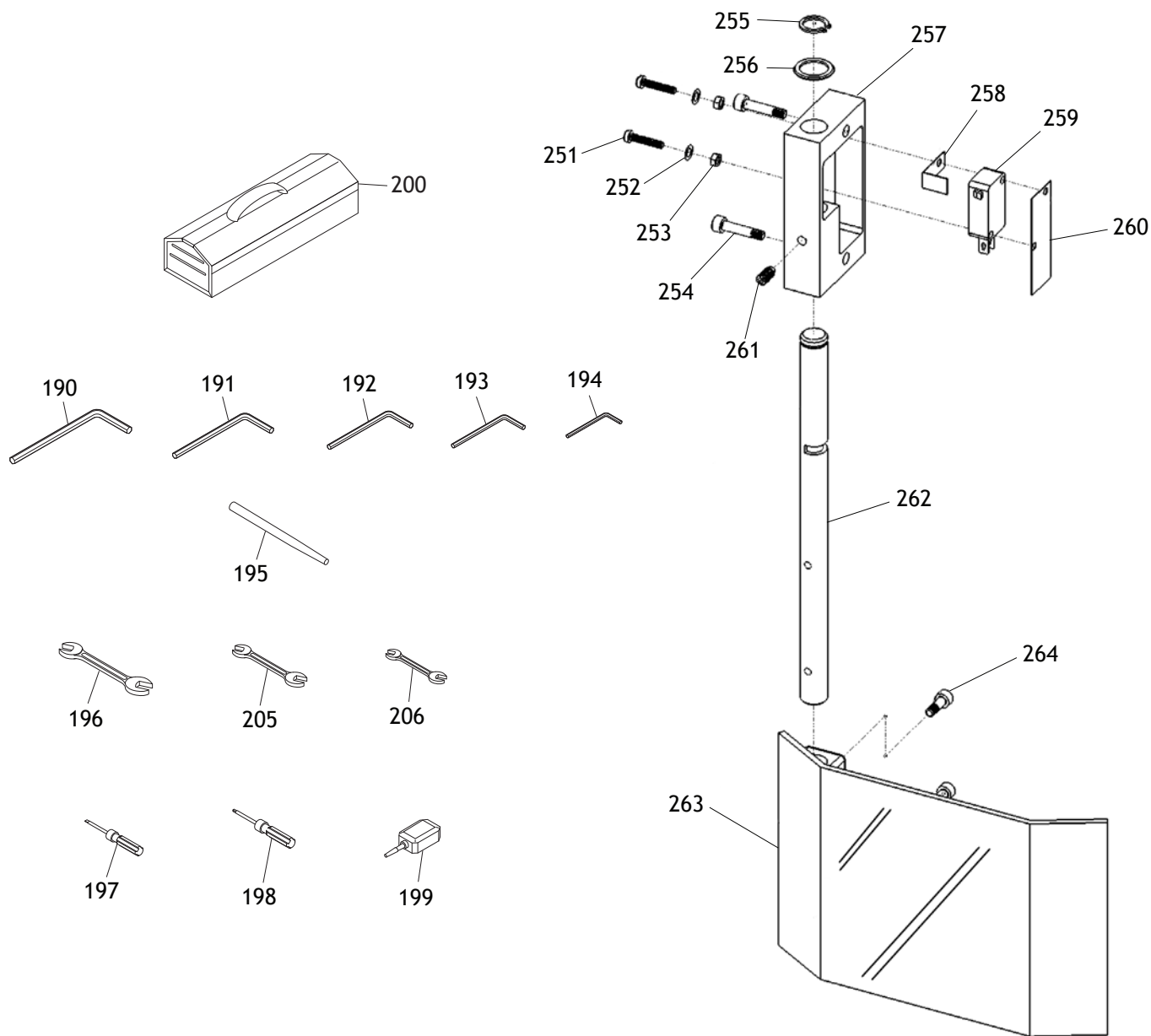

REF	PART #	DESCRIPTION
190	XM1116190	HEX WRENCH 6MM
191	XM1116191	HEX WRENCH 5MM
192	XM1116192	HEX WRENCH 4MM
193	XM1116193	HEX WRENCH 3MM
194	XM1116194	HEX WRENCH 2.5MM
195	XM1116195	SPINDLE PIN
196	XM1116196	WRENCH 17 X 19MM OPEN-ENDS
197	XM1116197	SCREWDRIVER FLAT #2
198	XM1116198	SCREWDRIVER PHILLIPS #2
199	XM1116199	BOTTLE FOR OIL
200	XM1116200	TOOLBOX
205	XM1116205	WRENCH 12 X 14MM OPEN-ENDS
206	XM1116206	WRENCH 8 X 10MM OPEN-ENDS
251	XM1116251	CAP SCREW M3-.5 X 16

REF	PART #	DESCRIPTION
252	XM1116252	FLAT WASHER 3MM
253	XM1116253	HEX NUT M3-.5
254	XM1116254	CAP SCREW M5-.8 X 15
255	XM1116255	EXT RETAINING RING 12MM
256	XM1116256	WAVY WASHER 20MM
257	XM1116257	GUARD MOUNTING BLOCK
258	XM1116258	LIMIT SWITCH L-BRACKET, COPPER
259	XM1116259	LIMIT SWITCH DATER KW1-103
260	XM1116260	PROTECTIVE PAPER
261	XM1116261	SET SCREW M5-.8 X 10
262	XM1116262	CHIP GUARD POST
263	XM1116263	CHIP GUARD
264	XM1116264	PHLP HD SCR M4-.7 X 10

Labels & Cosmetics

416

401

402

M1116

403

404

405

406

407

408
(D4780 only)

409

(D4780 only)

410

411

412

413

414

415

! WARNING

Safety labels warn about machine hazards and how to prevent serious personal injury. The owner of this machine **MUST** maintain the original location and readability of all labels on this machine. If any label is removed or becomes unreadable, **REPLACE** that label before allowing machine to be operated again. Contact us at (360) 734-3482 or www.woodstockint.com to order new labels.

REF	PART #	DESCRIPTION
401	XM1116401	READ MANUAL LABEL
402	XM1116402	MODEL NUMBER LABEL
403	XM1116403	SHOP FOX LABEL
404	XM1116404	EYE INJURY WARNING LABEL
405	XM1116405	ENTANGLEMENT HAZARD LABEL
406	XM1116406	HI/LO SPEED RANGE LABEL
407	XM1116407	GENERAL WARNINGS LABEL
408	XM1116408	SHOP FOX NAMEPLATE (D4780)

REF	PART #	DESCRIPTION
409	XM1116409	TIPPING HAZARD LABEL (D4780)
410	XM1116410	TOUCH-UP PAINT, SHOP FOX BLACK
411	XM1116411	TOUCH-UP PAINT, SHOP FOX WHITE
412	XM1116412	MACHINE ID LABEL
413	XM1116413	AVOID OVERHEATING MOTOR LABEL
414	XM1116414	DISCONNECT POWER LABEL
415	XM1116415	ELECTRICITY LABEL
416	XM1116416	CONTROL PANEL LABEL

Warranty Registration

Name _____

Street _____

City _____ State _____ Zip _____

Phone # _____ Email _____ Invoice # _____

Model # _____ Serial # _____ Dealer Name _____ Purchase Date _____

The following information is given on a voluntary basis. It will be used for marketing purposes to help us develop better products and services. Of course, all information is strictly confidential.

1. How did you learn about us?

Advertisement Friend Local Store
 Mail Order Catalog Website Other:

2. How long have you been a woodworker/metalworker?

0-2 Years 2-8 Years 8-20 Years 20+ Years

3. How many of your machines or tools are Shop Fox?

0-2 3-5 6-9 10+

4. Do you think your machine represents a good value? Yes No

5. Would you recommend Shop Fox products to a friend? Yes No

6. What is your age group?

20-29 30-39 40-49
 50-59 60-69 70+

7. What is your annual household income?

\$20,000-\$29,000 \$30,000-\$39,000 \$40,000-\$49,000
 \$50,000-\$59,000 \$60,000-\$69,000 \$70,000+

8. Which of the following magazines do you subscribe to?

<input type="checkbox"/> Cabinet Maker	<input type="checkbox"/> Popular Mechanics	<input type="checkbox"/> Today's Homeowner
<input type="checkbox"/> Family Handyman	<input type="checkbox"/> Popular Science	<input type="checkbox"/> Wood
<input type="checkbox"/> Hand Loader	<input type="checkbox"/> Popular Woodworking	<input type="checkbox"/> Wooden Boat
<input type="checkbox"/> Handy	<input type="checkbox"/> Practical Homeowner	<input type="checkbox"/> Woodshop News
<input type="checkbox"/> Home Shop Machinist	<input type="checkbox"/> Precision Shooter	<input type="checkbox"/> Woodsmith
<input type="checkbox"/> Journal of Light Cont.	<input type="checkbox"/> Projects in Metal	<input type="checkbox"/> Woodwork
<input type="checkbox"/> Live Steam	<input type="checkbox"/> RC Modeler	<input type="checkbox"/> Woodworker West
<input type="checkbox"/> Model Airplane News	<input type="checkbox"/> Rifle	<input type="checkbox"/> Woodworker's Journal
<input type="checkbox"/> Modeltec	<input type="checkbox"/> Shop Notes	<input type="checkbox"/> Other:
<input type="checkbox"/> Old House Journal	<input type="checkbox"/> Shotgun News	

9. Comments: _____

FOLD ALONG DOTTED LINE

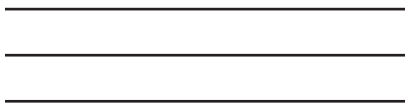

Place
Stamp
Here



WOODSTOCK INTERNATIONAL INC.
P.O. BOX 2309
BELLINGHAM, WA 98227-2309



FOLD ALONG DOTTED LINE

TAPE ALONG EDGES--PLEASE DO NOT STAPLE

WARRANTY

Woodstock International, Inc. warrants all Shop Fox machinery to be free of defects from workmanship and materials for a period of two years from the date of original purchase by the original owner. This warranty does not apply to defects due directly or indirectly to misuse, abuse, negligence or accidents, lack of maintenance, or reimbursement of third party expenses incurred.

Woodstock International, Inc. will repair, replace, or arrange for a dealer refund, at its expense and option, the Shop Fox machine or machine part proven to be defective for its designed and intended use, provided that the original owner returns the product prepaid to an authorized warranty or repair facility as designated by our Bellingham, Washington office with proof of their purchase of the product within two years, and provides Woodstock International, Inc. reasonable opportunity to verify the alleged defect through inspection. If it is determined there is no defect, or that the defect resulted from causes not within the scope of Woodstock International Inc.'s warranty, then the original owner must bear the cost of storing and returning the product.

This is Woodstock International, Inc.'s sole written warranty and any and all warranties that may be implied by law, including any merchantability or fitness, for any particular purpose, are hereby limited to the duration of this written warranty. We do not warrant that Shop Fox machinery complies with the provisions of any law, acts or electrical codes. We do not reimburse for third party repairs. In no event shall Woodstock International, Inc.'s liability under this limited warranty exceed the purchase price paid for the product, and any legal actions brought against Woodstock International, Inc. shall be tried in the State of Washington, County of Whatcom. We shall in no event be liable for death, injuries to persons or property or for incidental, contingent, special or consequential damages arising from the use of our products.

Every effort has been made to ensure that all Shop Fox machinery meets high quality and durability standards. We are committed to continuously improving the quality of our products, and reserve the right to change specifications at any time.



High Quality Machines and Tools

Woodstock International, Inc. carries thousands of products designed to meet the needs of today's woodworkers and metalworkers.

Ask your dealer about these fine products:

BROSWA
PRECISION STOP BLOCK

JOINTER PAL[®]

Rotacator[®]

THE REBEL[®]

DURASTICK[®]

Gutmann[®]

BOARD BUDDIES[®]

Junglee[®]

PLANER PAL[®]



PARROT VISE[®]

SLICKPLANE[®]

PRO-STIK[®]
ABRASIVE BELT & DISC CLEANER

ACCU-SHARP[®]



STEELEX[®]
PLUS

STEELEX[®]
FINE TOOLS

Aluma-Classic[®]

WHOLESALE ONLY

WOODSTOCK INTERNATIONAL, INC.

Phone: (360) 734-3482 • Fax: (360) 671-3053 • Toll Free Fax: (800) 647-8801

P.O.Box 2309 • Bellingham, WA 98227

SHOPFOX.BIZ