

MODEL M1011 24" PAN AND BOX BRAKE



INSTRUCTION MANUAL

Phone: 1-360-734-3482 • On-Line Technical Support: tech-support@shopfox.biz

COPYRIGHT © SEPTEMBER, 2004 BY WOODSTOCK INTERNATIONAL, INC. REVISED MAY, 2012 (TR)

WARNING: NO PORTION OF THIS MANUAL MAY BE REPRODUCED IN ANY SHAPE OR FORM WITHOUT

THE WRITTEN APPROVAL OF WOODSTOCK INTERNATIONAL, INC.

Contents

INTRODUCTION 2

 Woodstock Technical Support 2

 About Your New 24" Pan and Box Brake 2

 Specifications 2

 Controls and Features 3

SAFETY 4

 Standard Safety Instructions 4

 Safety Instructions for Pan and Box Brakes 5

SET UP 6

 Unpacking 6

 Inventory 6

 Cleaning 6

 Tool Placement 7

 Mounting 7

OPERATIONS 8

 General 8

MAINTENANCE 9

 General 9

 Cleaning and Lubrication 9

PARTS 10

WARRANTY 12

USE THE QUICK GUIDE PAGE LABELS TO SEARCH OUT INFORMATION FAST!





INTRODUCTION

Woodstock Technical Support

We stand behind our machines! In the event that a defect is found, parts are missing or questions arise about your machine, please contact Woodstock International Technical Support at 1-360-734-3482 or send e-mail to: tech-support@shopfox.biz. Our knowledgeable staff will help you troubleshoot problems, send out parts or arrange warranty returns.

If you need the latest edition of this manual, you can download it from <http://www.shopfox.biz>. If you still have questions after reading the latest manual, or if you have comments please contact us at:

Woodstock International, Inc.
Attn: Technical Support Department
P.O. Box 2309
Bellingham, WA 98227

About Your New 24" Pan and Box Brake

Your new SHOP FOX® 24" Pan and Box Brake has been specially designed to provide many years of trouble-free service. Close attention to detail, ruggedly built parts and a rigid quality control program assure safe and reliable operation.

This pan and box brake is an indispensable tool if you need to increase the strength of sheet metal plates with bends, or you intend on fabricating more complicated brackets, gussets, boxes, and fixtures. When bolted to a secure workbench, your pan and box brake allows you easily bend 24" wide mild steels up to 20 gauge (1mm) thick in a range of angles from 0° to 135°. The removable and adjustable fingers can be installed in a variety of positions to accommodate for varying widths of metal.

Woodstock International, Inc. is committed to customer satisfaction in providing this manual. It is our intent to make sure all the information necessary for safety, ease of assembly, practical use and durability of this product are included.

Specifications

- Dimensions..... 11" Tall x 30-11/16 Wide x 14" Deep
- Working Height..... 9"
- Maximum Steel Width..... 24"
- Maximum Steel Thickness 20 Gauge (1mm)
- Approximate Pan and Box Brake Weight 110 lbs.

Controls and Features

Use the list below and Figure 1 to become familiar with your new pan and box brake.

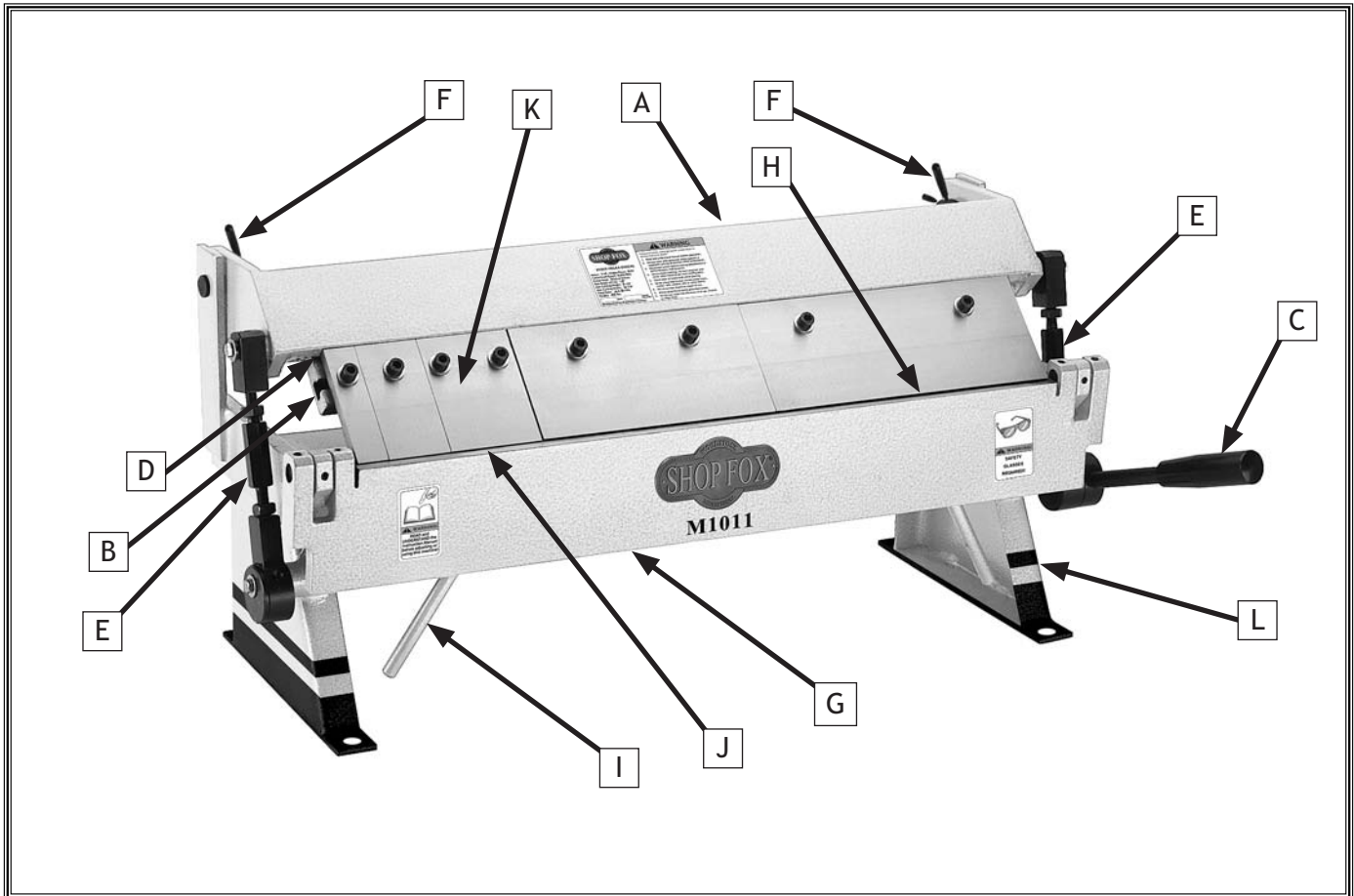

Figure 1. Typical M1011 24" Pan and box brake controls and features.

- | | |
|--|---|
| <p>A. Holddown Assembly—Applies clamping pressure to the sheet metal to be bent.</p> <p>B. Holddown Finger Channel—Allows for the finger T-nut to slide down the length of the holddown to adjust for different widths of sheet metal.</p> <p>C. Holddown Clamping Lever—Allows you to clamp and unclamp the sheet metal through the cam mechanism.</p> <p>D. Holddown Stop Flange—Allows for quick indexing of one or many fingers.</p> <p>E. Holddown Height Turnbuckle—Allows for adjusting the holddown clamping height so metal of various thicknesses can be clamped and bent.</p> <p>F. Finger Position Control—Allows for adjusting the holddown and fingers to move them closer or farther away from the point of bend.</p> | <p>G. Apron—Allows for even bending and support for sheet metal.</p> <p>H. Apron Face—Applies even pressure along the surface of the sheet metal during the bend.</p> <p>I. Apron Lever—Allows you to bend the sheet metal with two levers.</p> <p>J. Finger Knife-Edge—Allows for extremely sharp bend if required.</p> <p>K. High-Strength Fingers—Allows for bending many different widths of metal.</p> <p>L. Body—Supports all components and is drilled for mounting on a heavy duty workbench.</p> |
|--|---|

SAFETY

**READ MANUAL BEFORE OPERATING MACHINE.
FAILURE TO FOLLOW INSTRUCTIONS BELOW WILL
RESULT IN PERSONAL INJURY.**



Indicates an imminently hazardous situation which, if not avoided, **WILL** result in death or serious injury.



Indicates a potentially hazardous situation which, if not avoided, **COULD** result in death or serious injury.



Indicates a potentially hazardous situation which, if not avoided, **MAY** result in minor or moderate injury.

NOTICE

This symbol is used to alert the user to useful information about proper operation of the tool, and/or a situation that may cause damage to the tool.

Standard Safety Instructions

1. **Read and understand the Instruction Manual before operating this tool.** Learn the applications, limitations and potential hazards of this tool. Keep the manual in a safe and convenient place for future reference.
2. **Keep work area clean and well lighted.** Clutter and inadequate lighting invite potential hazards.
3. **Wear eye protection at all times.** Use safety glasses with side shields or safety goggles that meet the appropriate standards of the American National Standards Institute (ANSI).
4. **Ensure all safety guards are securely in place** and in working condition.
5. **Keep work area clean, free of clutter, grease, etc.**
6. **Keep children and visitors away.** Visitors must be kept at a safe distance while operating unit.
7. **Childproof your workshop and dangerous tools** with padlocks, master switches or by removing starter keys where applicable.
8. **Do not force tool.** The tool will do a safer and better job at the rate for which it was designed.
9. **Use correct tool.** Do not force the tool or attachment to do a job for which it was not designed.
10. **Wear proper apparel.** Do not wear loose clothing, neck ties, gloves, jewelry, and secure long hair away from moving parts.
11. **Keep proper footing and balance** at all times.

12. **Perform tool maintenance and care.** Follow lubrication and pre-use inspections listed in the manual.
13. **If at any time you are experiencing difficulties** performing the intended operation, stop using the tool! Then contact our Technical Support Department or ask a qualified expert how the operation should be performed.
14. **Habits—good and bad—are hard to break.** Develop good habits in your shop and safety will become second-nature to you.

Safety Instructions for Pan and Box Brakes

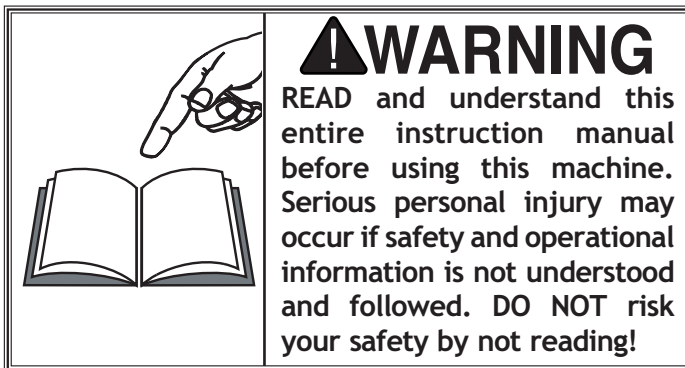

1. **Do Not overload the pan and box brake.** Bend 20 gauge (1mm thick) or thinner metal. Overloading this tool can cause injury from flying parts.
2. **Do Not use a torch near the fingers.** Heating metal with a torch while the metal is in the pan and box brake will weaken the fingers.
3. **Always chamfer and de-burr sharp sheet metal edges.** Sharp edges on sheet metal can cut your fingers to the bone. Always chamfer and de-burr sheet metal before bending in the pan and box brake.
4. **Always wear leather gloves and approved safety glasses when using this tool.**
5. **If at any time you are experiencing difficulties performing the intended operation, STOP** using the tool and contact our Technical Support Department, or ask a qualified expert how the operation should be performed.
6. **Never use tools that are in poor condition.** Inspect the pan and box brake for any cracked linkage, levers, or loose fasteners. Correct any problems before use.

SET UP

Unpacking

The SHOP FOX® Model M1011 has been carefully packaged for safe transporting. If you notice the machine has been damaged, please contact Woodstock International Technical Support at 1-360-734-3482 or send e-mail to: tech-support@shopfox.biz



! WARNING

SUFFOCATION HAZARD!

Immediately discard all plastic bags and packing materials to eliminate a choking and suffocation hazard for children and animals.

! WARNING



READ and understand this entire instruction manual before using this tool. Serious personal injury may occur if safety and operational information is not understood and followed. DO NOT risk your safety by not reading!

SETUP

Inventory

The following is a list of the parts components shipped with the SHOP FOX® Model M1011.

Box Contents:

- A. Lever1
- B. 24" Pan and Box Brake1
- C. 1" Fingers2
- D. 2" Fingers4
- E. 3" Fingers2
- F. 4" Fingers2

Should any part be missing, examine the packaging carefully to be sure those parts are not among the packing materials. If any parts are missing, find the part number in the back of this manual and contact Woodstock International, Inc. at 360-734-3482 or at tech-support@shopfox.biz

Cleaning

1. Remove the fingers from the pan and box brake.
2. Clean the protective coating from machine surfaces and fingers. **Note:** Use a mild solvent and soft rag. Harsh solvents like thinners, gasoline, acetone etc. will damage painted surfaces and can permanently etch metal surfaces
3. Place a light coat of machine oil on all machined surfaces to prevent rust.

Tool Placement

- **Workbench Load:** Make sure that your workbench is strong enough to support the pan and box brake and the work pieces that will be bent. The workbench should not move when you are bending sheet metal.
- **Working Clearances:** Consider existing and anticipated needs, size of material to be processed through the tool, and the space needed for auxiliary stands, work tables or other machinery when establishing a location for your pan and box brake.
- **Lighting:** Lighting should be bright enough to eliminate shadow and prevent eye strain.

Mounting

A securely mounted pan and box brake gives you a better feel for the amount of sheet metal "spring back" and give you excellent control during the bending process.

To mount the pan and box brake, do these steps:

1. Mount the Model M1011 to a flat and level work surface, which is solid enough to hold the pan and box brake and the work material.
2. Place the pan and box brake onto the work surface and make sure there is adequate work room on all sides.
3. Use a pen or pencil to transfer the hole locations to the mounting surface.
4. Drill four $\frac{3}{8}$ " diameter holes in the work surface.
5. Mount the pan and box brake to the work surface using $\frac{5}{16}$ " bolts, washers, and nuts.



OPERATIONS

General

This pan and box brake is an indispensable tool if you need to increase the strength of sheet metal plates with bends, or you intend on fabricating more complicated brackets, gussets, boxes, and fixtures.

This manual covers initial setup and describes pan and box brake functions. Not covered is how to avoid problems with cracks in bends or compensate for structural problems in the various types of metal you bend. These problems can be solved by understanding the bendability properties of metal, how to calculate the maximum and minimum bend radius, spring back values, and bend allowances.

Refer to publications and training if needed to understand the mechanics of metal bending. With an increased knowledge and practice, you will be able to fabricate excellent sheet metal items.

To make a basic bend, do these steps:

1. Seat and install enough fingers against the holddown stop flange, to match the width of metal to be bent (see Figure 2).
2. Lift the hold down lever (see Figure 3), and insert the sheet metal between the fingers and apron.
3. Align the sheet metal bend mark with the apron edge, and lightly clamp the sheet metal in place. If the lever is hard to lock in position, adjust both holddown lock turnbuckles (see Figure 2) to accept the workpiece thickness.
4. Adjust both finger setback cam levers to adjust the fingers in or out, so the finger tips are set back from the apron edge a minimum of 1-1/2 times the metal thickness. **Note:** If the finger tips are any closer, you will damage the finger tips during the bend.
5. Lower the hold down lever and clamp the sheet metal in place. **Note:** Do not force the hold down lever.
6. Lift up on the apron levers until the sheet metal bend angle is at your desired angle.

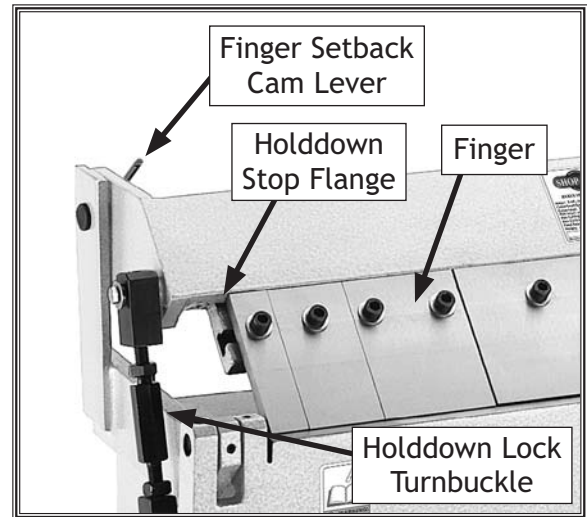

Figure 2. Fingers and turnbuckle.

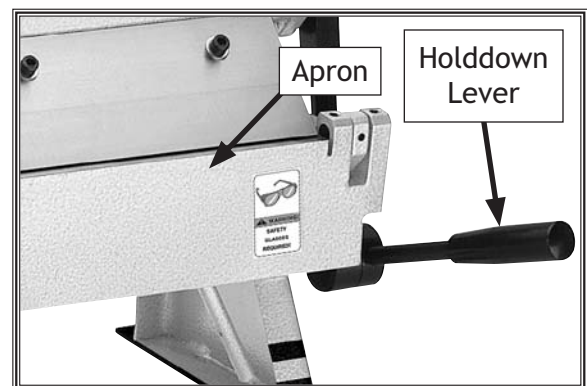

Figure 3. Holddown lever.

MAINTENANCE

General

Regular periodic maintenance will ensure optimum pan and box brake performance. Make a habit of inspecting your pan and box brake each time you use it.

Check for the following conditions and repair or replace when necessary:

- Loose mounting bolts.
- Worn fingers.
- Worn or cracked pivot pins or links.
- Bent or cracked levers.
- Any other condition that could hamper the safe operation of this tool.

Cleaning and Lubrication

1. Clean the machined surfaces so no metal shavings, burrs, or foreign material exists.
Note: Use a mild solvent and soft rag. Harsh solvents like thinners, gasoline, acetone will damage painted surfaces and can permanently etch metal surfaces.
2. Wipe a light coat of machine oil on all machined surfaces to prevent rust and apply a drop of machine oil at the locations shown in **Figure 4**.

	<p>CAUTION</p> <p>NEVER use gasoline or other petroleum-based solvents to clean with. ALWAYS work in well-ventilated areas far from possible ignition sources when using solvents to clean machinery. Many solvents are toxic when inhaled or ingested. Use care when disposing of waste rags and towels to be sure they do not create fire or environmental hazards.</p>
--	--

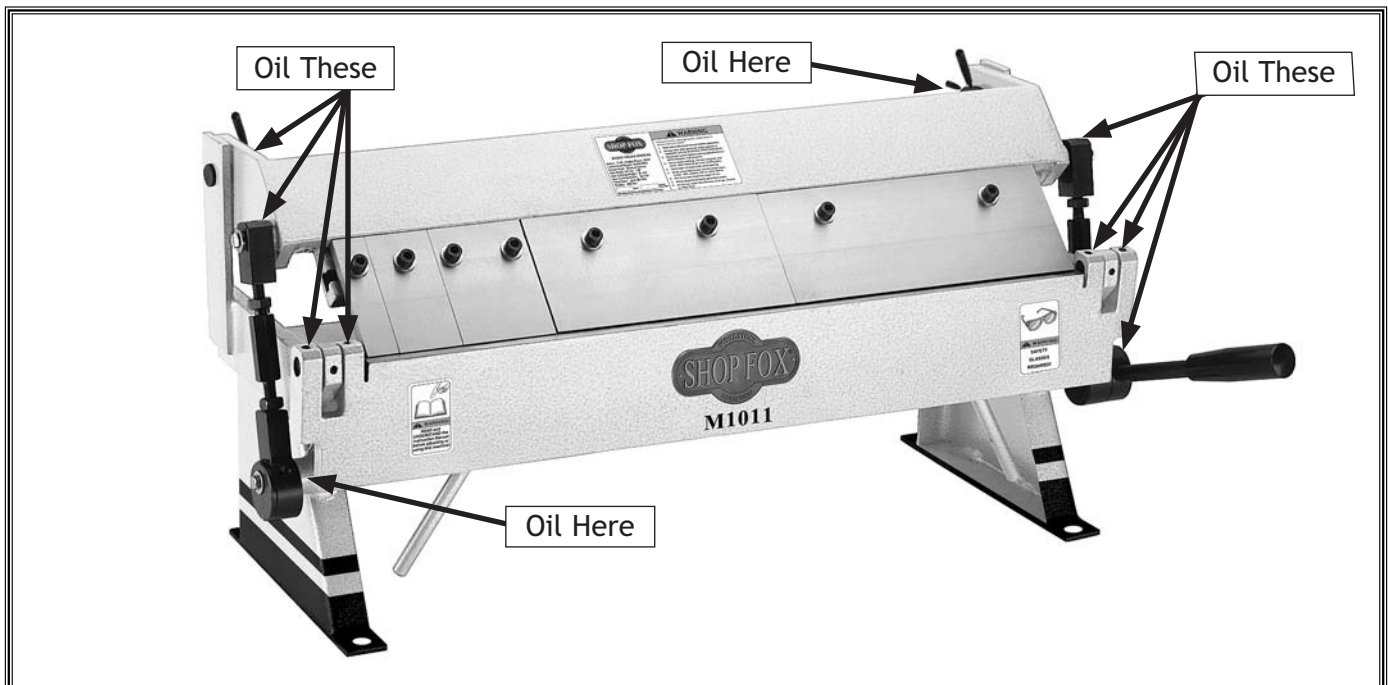
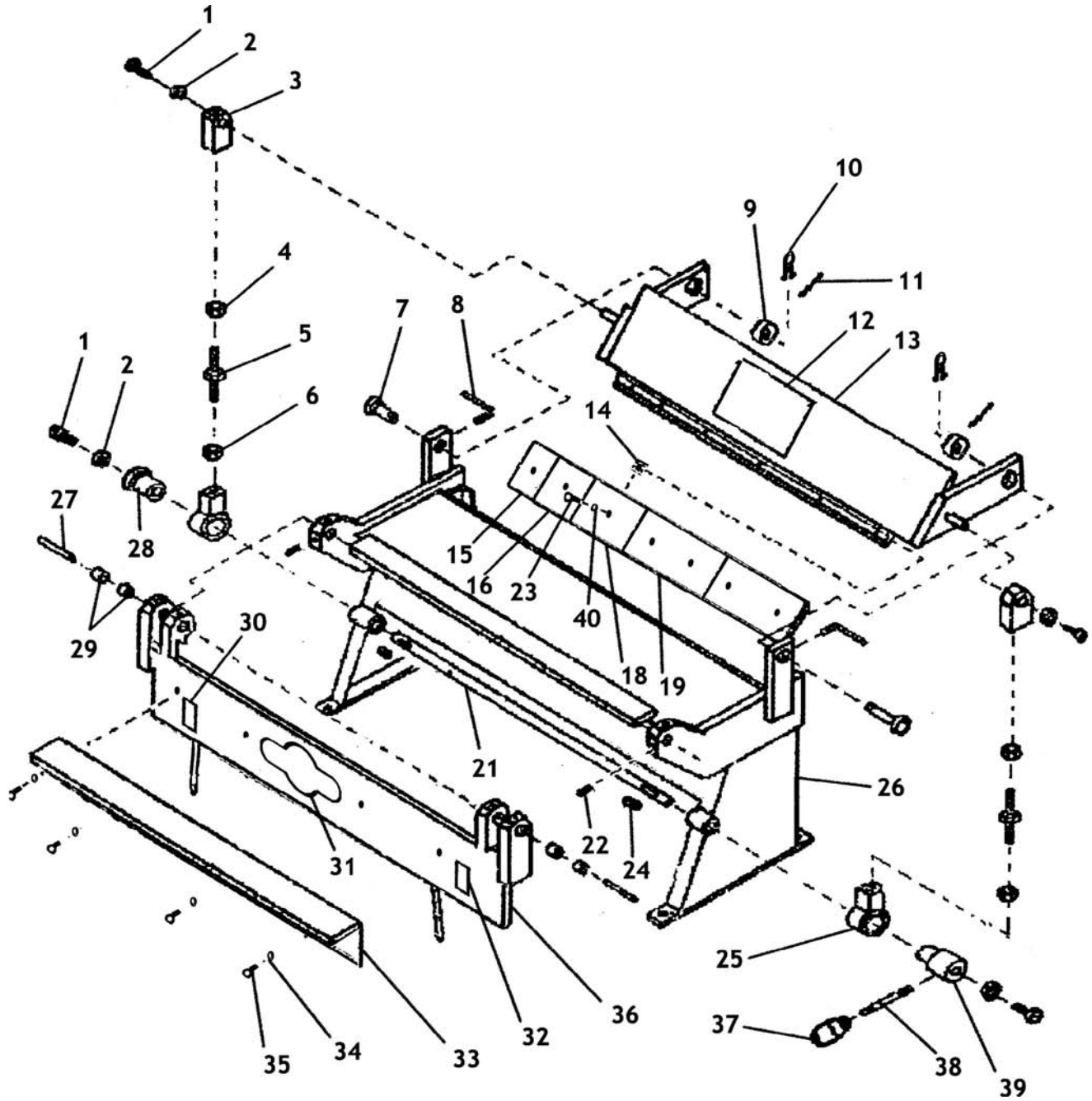

Figure 4. Lubrication points.



PARTS



REF	PART #	DESCRIPTION
1	XPSB04M	CAP SCREW M6-1 X 10
2	XPW03M	FLAT WASHER 6MM
3	XM1011003	CONNECTING BLOCK
4	XPN02M	HEX NUT M10-1.5
5	XM1011005	TURNBUCKLE
6	XPN02M	HEX NUT M10-1.5
7	XM1011007	PIN SHAFT
8	XM1011008	LOCK LEVER
9	XM1011009	UPPER ECCENTRIC
10	XM1011010	SPLIT PIN
11	XM1011011	LEVER
12	XM1011012	MACHINE ID LABEL
13	XM1011013	HOLD DOWN ASSEMBLY
14	XM1011014	T-NUT
15	XM1011015	FINGER (1")
16	XM1011016	FINGER (2")
18	XM1011018	FINGER (3")
19	XM1011019	FINGER (4")
21	XM1011021	SHAFT

REF	PART #	DESCRIPTION
22	XPSS01M	SET SCREW M6-1.0 X 10
23	XPSB14M	CAP SCREW M8-1.25 X 20
24	XPK47M	KEY 4 X 4 X 15MM
25	XM1011025	BUSHING
26	XM1011026	BODY
27	XM1011027	SMALL SHAFT
28	XM1011028	LOWER LEFT ECCENTRIC
29	XM1011029	BUSHING
30	XM1011030	READ MANUAL LABEL
31	XM1011031	SHOP FOX LOGO
32	XM1011032	SAFETY GLASSES LABEL
33	XM1011033	APRON ANGLE
34	XPW01M	FLAT WASHER 8MM
35	XPB85M	HEX BOLT M8-1.25 X 18
36	XM1011036	APRON
37	XM1011037	HANDLE
38	XM1011038	SCREW ROD
39	XM1011039	LOWER RIGHT ECCENTRIC
40	XPW01M	FLAT WASHER 8MM

WARRANTY

Woodstock International, Inc. warrants all **SHOP FOX**[®] machinery to be free of defects from workmanship and materials for a period of 2 years from the date of original purchase by the original owner. This warranty does not apply to defects due directly or indirectly to misuse, abuse, negligence or accidents, lack of maintenance, or to repairs or alterations made or specifically authorized by anyone other than Woodstock International, Inc.

Woodstock International, Inc. will repair or replace, at its expense and at its option, the **SHOP FOX**[®] machine or machine part which in normal use has proven to be defective, provided that the original owner returns the product prepaid to the **SHOP FOX**[®] factory service center or authorized repair facility designated by our Bellingham, WA office, with proof of their purchase of the product within 2 years, and provides Woodstock International, Inc. reasonable opportunity to verify the alleged defect through inspection. If it is determined there is no defect, or that the defect resulted from causes not within the scope of Woodstock International Inc.'s warranty, then the original owner must bear the cost of storing and returning the product.

This is Woodstock International, Inc.'s sole written warranty and any and all warranties that may be implied by law, including any merchantability or fitness, for any particular purpose, are hereby limited to the duration of this written warranty. We do not warrant that **SHOP FOX**[®] machinery complies with the provisions of any law or acts. In no event shall Woodstock International, Inc.'s liability under this warranty exceed the purchase price paid for the product, and any legal actions brought against Woodstock International, Inc. shall be tried in the State of Washington, County of Whatcom. We shall in no event be liable for death, injuries to persons or property or for incidental, contingent, special or consequential damages arising from the use of our products.

Every effort has been made to ensure that all **SHOP FOX**[®] machinery meets high quality and durability standards. We reserve the right to change specifications at any time because of our commitment to continuously improve the quality of our products.

WARRANTY REGISTRATION

Name _____

Street _____

City _____ State _____ Zip _____

Phone Number _____ E-Mail _____ FAX _____

MODEL # _____ SERIAL # _____ DEALER NAME _____ PURCHASE DATE ____ / ____ / ____

The following information is given on a voluntary basis and is strictly confidential.

CUT ALONG DOTTED LINE

1. How did you first learn about us? 9. What stationary woodworking tools do you own? Check all that apply.

<input type="checkbox"/> Advertisement <input type="checkbox"/> Friend <input type="checkbox"/> Mail order Catalog <input type="checkbox"/> Local Store <input type="checkbox"/> World Wide Web Site <input type="checkbox"/> Other _____	<input type="checkbox"/> Air Compressor <input type="checkbox"/> Panel Saw <input type="checkbox"/> Band Saw <input type="checkbox"/> Planer <input type="checkbox"/> Drill Press <input type="checkbox"/> Power Feeder <input type="checkbox"/> Drum Sander <input type="checkbox"/> Radial Arm Saw <input type="checkbox"/> Dust Collector <input type="checkbox"/> Shaper <input type="checkbox"/> Horizontal Boring Machine <input type="checkbox"/> Spindle Sander <input type="checkbox"/> Jointer <input type="checkbox"/> Table Saw <input type="checkbox"/> Lathe <input type="checkbox"/> Vacuum Veneer Press <input type="checkbox"/> Mortiser <input type="checkbox"/> Wide Belt Sander <input type="checkbox"/> Other _____
--	--

2. Which of the following magazines do you subscribe to.

<input type="checkbox"/> Cabinetmaker <input type="checkbox"/> Family Handyman <input type="checkbox"/> Fine Homebuilding <input type="checkbox"/> Woodsmith <input type="checkbox"/> Home Handyman <input type="checkbox"/> Journal of Light Construction <input type="checkbox"/> Old House Journal <input type="checkbox"/> Popular Mechanics <input type="checkbox"/> Popular Science <input type="checkbox"/> Popular Woodworking <input type="checkbox"/> Other _____	<input type="checkbox"/> WOOD <input type="checkbox"/> Wooden Boat <input type="checkbox"/> Woodshop News <input type="checkbox"/> Today's Homeowner <input type="checkbox"/> Woodwork <input type="checkbox"/> Woodworker <input type="checkbox"/> Woodworker's Journal <input type="checkbox"/> Workbench <input type="checkbox"/> American How-To
---	--

10. Which benchtop tools do you own? Check all that apply.

<input type="checkbox"/> 1" x 42" Belt Sander <input type="checkbox"/> 5" - 8" Drill Press <input type="checkbox"/> 8" Table Saw <input type="checkbox"/> 8" - 10" Bandsaw <input type="checkbox"/> Disc/Belt Sander <input type="checkbox"/> Mini Jointer <input type="checkbox"/> Other _____	<input type="checkbox"/> 6" - 8" Grinder <input type="checkbox"/> Mini Lathe <input type="checkbox"/> 10" - 12" Thickness Planer <input type="checkbox"/> Scroll Saw <input type="checkbox"/> Spindle/Belt Sander
---	---

3. Which of the following woodworking/remodeling shows do you watch?

<input type="checkbox"/> Backyard America <input type="checkbox"/> Home Time <input type="checkbox"/> The American Woodworker <input type="checkbox"/> Other _____	<input type="checkbox"/> The New Yankee Workshop <input type="checkbox"/> This Old House <input type="checkbox"/> Woodwright's Shop
---	---

11. Which portable/hand held power tools do you own? Check all that apply.

<input type="checkbox"/> Belt Sander <input type="checkbox"/> Biscuit Joiner <input type="checkbox"/> Circular Saw <input type="checkbox"/> Detail Sander <input type="checkbox"/> Drill/Driver <input type="checkbox"/> Miter Saw <input type="checkbox"/> Other _____	<input type="checkbox"/> Orbital Sander <input type="checkbox"/> Palm Sander <input type="checkbox"/> Portable Planer <input type="checkbox"/> Saber Saw <input type="checkbox"/> Reciprocating Saw <input type="checkbox"/> Router
---	--

4. What is your annual household income?

<input type="checkbox"/> \$20,000-\$29,999 <input type="checkbox"/> \$30,000-\$39,999 <input type="checkbox"/> \$40,000-\$49,999 <input type="checkbox"/> \$50,000-\$59,999	<input type="checkbox"/> \$60,000-\$69,999 <input type="checkbox"/> \$70,000-\$79,999 <input type="checkbox"/> \$80,000-\$89,999 <input type="checkbox"/> \$90,000 +
--	---

12. What machines/supplies would you like to see?

5. What is your age group?

<input type="checkbox"/> 20-29 <input type="checkbox"/> 30-39 <input type="checkbox"/> 40-49	<input type="checkbox"/> 50-59 <input type="checkbox"/> 60-69 <input type="checkbox"/> 70 +
--	---

13. What new accessories would you like Woodstock International to carry?

6. How long have you been a woodworker?

<input type="checkbox"/> 0 - 2 Years <input type="checkbox"/> 2 - 8 Years	<input type="checkbox"/> 8 - 20 Years <input type="checkbox"/> 20+ Years
--	---

14. Do you think your purchase represents good value?

Yes No

7. How would you rank your woodworking skills?

<input type="checkbox"/> Simple <input type="checkbox"/> Intermediate	<input type="checkbox"/> Advanced <input type="checkbox"/> Master Craftsman
--	--

15. Would you recommend **SHOP FOX®** products to a friend?

Yes No

8. How many **SHOP FOX®** machines do you own? _____

16. Comments: _____

FOLD ALONG DOTTED LINE

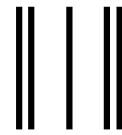
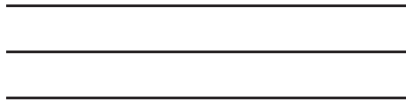

Place
Stamp
Here

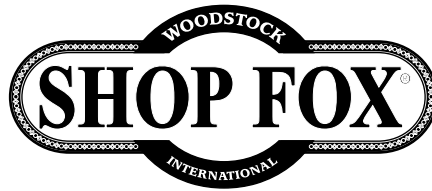

WOODSTOCK INTERNATIONAL INC.
P.O. BOX 2309
BELLINGHAM, WA 98227-2309



FOLD ALONG DOTTED LINE

TAPE ALONG EDGES--PLEASE DO NOT STAPLE