

Grizzly *Industrial, Inc.*®

1" X 30" BELT/5" DISC SANDER MODEL H6070 INSTRUCTION MANUAL

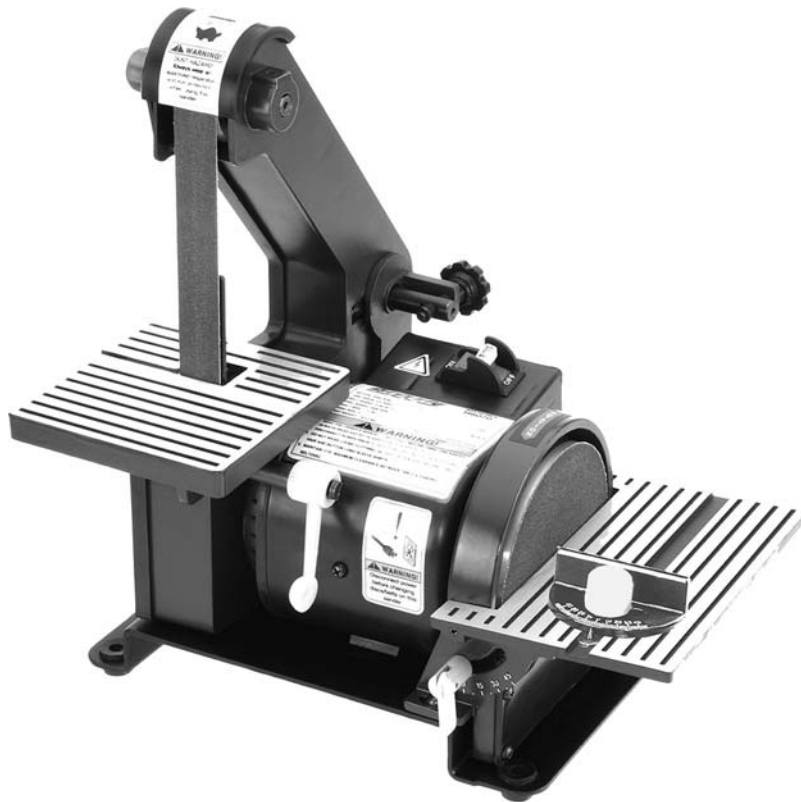

COPYRIGHT © APRIL 2004, BY GRIZZLY INDUSTRIAL, INC.
**WARNING: NO PORTION OF THIS MANUAL MAY BE REPRODUCED IN ANY SHAPE
OR FORM WITHOUT THE WRITTEN APPROVAL OF GRIZZLY INDUSTRIAL, INC.**
#6230 PRINTED IN CHINA

WARNING

Some dust created by power sanding, sawing, grinding, drilling, and other construction activities contains chemicals known to the State of California to cause cancer, birth defects or other reproductive harm. Some examples of these chemicals are:

- Lead from lead-based paints.
- Crystalline silica from bricks, cement, and other masonry products.
- Arsenic and chromium from chemically treated lumber.

Your risk from these exposures varies, depending on how often you do this type of work. To reduce your exposure to these chemicals: work in a well ventilated area, and work with approved safety equipment, such as those dust masks that are specially designed to filter out microscopic particles.

Table of Contents

SECTION 1: INTRODUCTION	2
Foreword ...Đ	2
Contact InfoĐ	2
Identification	3
H6070 Machine Data Sheet.....	4
SECTION 2: SAFETY.....	5
Safety Instructions for Power Tools	5
Additional Safety Instructions for Sanders	7
SECTION 3: CIRCUIT REQUIREMENTS	8
Motor Amp Draw	8
Grounding...Đ	8
Circuit Breaker	8
Minimum Cord Size.....	8
SECTION 4: SET UP	9
About this Section	9
Unpacking ..Đ	9
Inventory...Đ	10
Hardware Recognition Chart.....	11
Site Considerations	12
Disc Table and Guard	13
Sanding Belt Table.....	14
Sanding Belt.....	15
Sanding Disc	16
Belt Tracking	17
PlatenĐ	18
Table Squaring.....	18
Mounting...Đ	19
SECTION 5: OPERATIONS.....	20
Safe Operation	20
Starting the Sander	20
Disc End-Sanding	21
Belt End-Sanding	21
Contour Sanding	22
Chisel Sharpening.....	22
SECTION 6: MAINTENANCE	23
Schedule ..Đ	23
Troubleshooting.....	24
H6070 Parts Breakdown	25
H6070 Wiring Diagram.....	27
Warranty & Returns.....	28

SECTION 1: INTRODUCTION

Foreword

We are proud to offer the Model H6070 1" x 30" Belt/5" Disc Sander. This machine is part of a growing Grizzly family of fine woodworking machinery. When used according to the guidelines set forth in this manual, you can expect years of trouble-free, enjoyable operation and proof of Grizzly's commitment to customer satisfaction.

We are pleased to provide this manual with the Model H6070. It was written to guide you through assembly, review safety considerations, and cover general operating procedures. It represents our effort to produce the best documentation possible.

The specifications, drawings, and photographs illustrated in this manual represent the Model H6070 as supplied when the manual was prepared. However, owing to Grizzly's policy of continuous improvement, changes may be made at any time with no obligation on the part of Grizzly. For your convenience, we always keep current Grizzly manuals available on our website at www.grizzly.com. Any updates to your machine will be reflected in these manuals as soon as they are complete. Visit our site often to check for the latest updates to this manual!



Contact Info

If you have any comments regarding this manual, please write to us at the address below:

Grizzly Industrial, Inc.
c/o Technical Documentation
P.O. Box 2069
Bellingham, WA 98227-2069

We stand behind our machines. If you have any service questions or parts requests, please call or write us at the location listed below.

Grizzly Industrial, Inc.
1203 Lycoming Mall Circle
Muncy, PA 17756
Phone: (570) 546-9663
Fax: (800) 438-5901
E-Mail: techsupport@grizzly.com
Web Site: <http://www.grizzly.com>



Identification

Compare the list of components and features below with **Figure 1** to become familiar with your new sander. This knowledge will help you understand the manual, and how to assemble and safely use the sander.

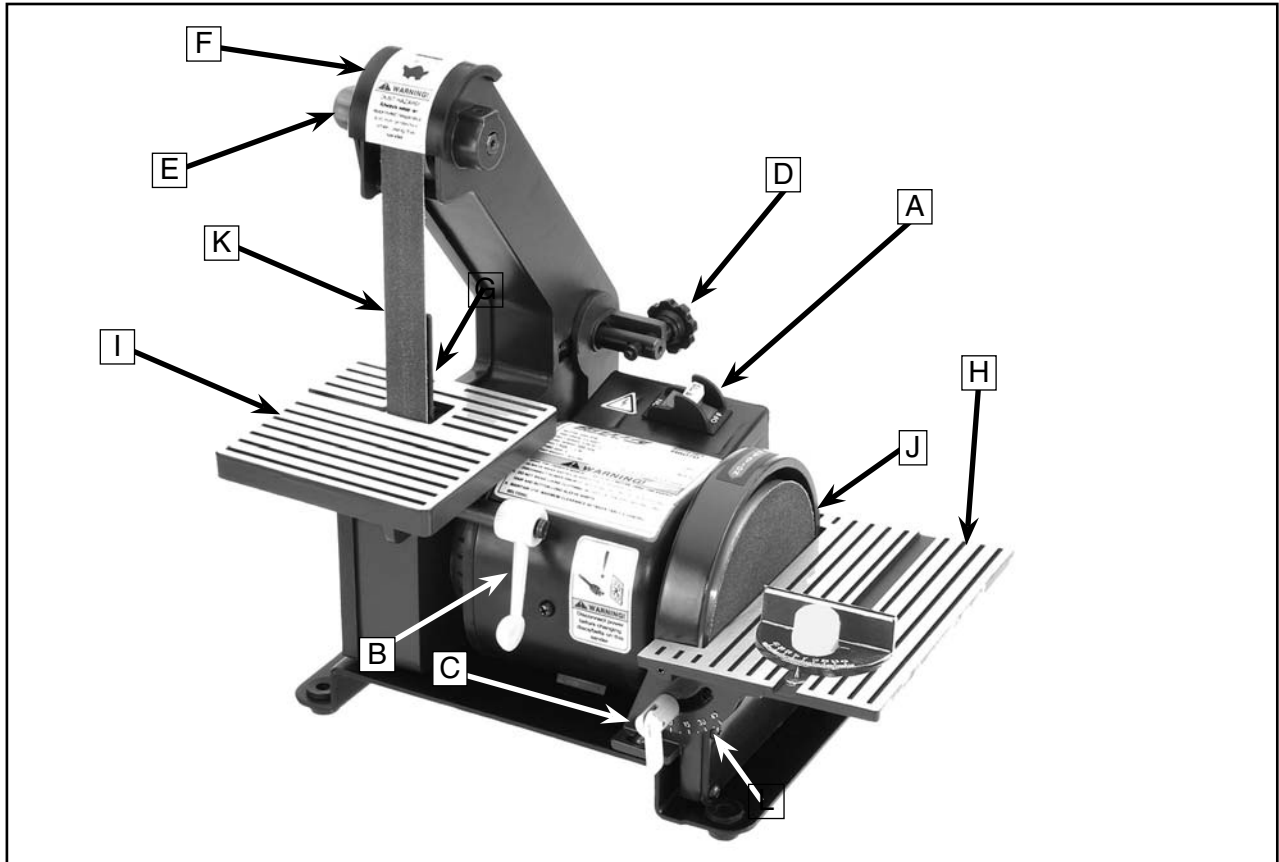

Figure 1. Belt/disc sander components and controls.

- A. ON/OFF Switch**—Toggles power to sander.
- B. Table Lock Lever**—Locks belt sanding table to desired angle.
- C. Table Lock Lever**—Locks disc sanding table to desired angle.
- D. Tracking Knob**—Sets belt to correct tracking.
- E. Belt Guard Lock Knob**—Locks the belt guard in place.
- F. Belt Guard**—Protects user from flying debris.
- G. Belt Platen**—Supports the belt during sanding.
- H. Sanding Disc Table**—Supports the workpiece at various angles for disc sanding.
- I. Sanding Belt Table**—Supports the workpiece at various angles for belt sanding.
- J. Abrasive Disc**—General duty self-adhesive sanding disc.
- K. Abrasive Belt**—General duty directional sanding belt.
- L. Tilt Scale**—Indicates the tilt of the sanding disc table.



MACHINE DATA SHEET

Customer Service #: (570) 546-9663 • To Order Call: (800) 523-4777 • Fax #: (800) 438-5901

H6070 1" x 30" Belt/5" Disc Sander

Design Type Bench Model

Overall Dimensions:

Belt Table Size 5 $\frac{1}{8}$ " W x 5 $\frac{1}{8}$ " D
 Disc Table Size 4" W x 7 $\frac{5}{16}$ " D
 Overall Width 14"
 Overall Depth 10 $\frac{3}{4}$ "
 Overall Height 14 $\frac{1}{2}$ "
 Shipping Weight 21 lbs.
 Machine Weight 19 lbs.

Capacities:

Belt Speed..... 3150 SFP
 Table Tilt Range..... 0°-45°
 Disc Dust Chute Port O.D..... 1 $\frac{13}{16}$ "
 Belt Dust Chute Port O.D..... 1 $\frac{3}{4}$ "
 Belt Size 1" x 30"
 Disc Size Diameter..... 5"
 Disc Speed..... 3450 RPM

Construction:

Table Ground Cast Aluminum
 Stand Punched Steel
 Spindle Bearings Ball Bearings, Sealed and Lubricated for Life

Motor:

Type TEFC Induction
 Horsepower $\frac{1}{3}$ " HP
 Phase / Voltage Single-Phase / 110V
 Amps 2.5A
 Cycle / RPM..... 60 Hertz / 3450 RPM
 Switch..... 110V Toggle w/Safety Key
 Bearings Shielded & Lubricated Ball Bearings

Features:

..... Dual Dust Ports
 Safety Guards
 Adjustable Platen
 Universal Positioning Lock Levers
 Removable Safety Key
 Machined Aluminum Tables
 Takes Standard 1" x 30" belts and 5 discs
 Manual Belt Tracking Adjustment
 Rubber Foot Mounting

Specifications, while deemed accurate, are not guaranteed.

SECTION 2: SAFETY

WARNING

For Your Own Safety Read Instruction Manual Before Operating This Equipment

The purpose of safety symbols is to attract your attention to possible hazardous conditions. This manual uses a series of symbols and signal words which are intended to convey the level of importance of the safety messages. The progression of symbols is described below. Remember that safety messages by themselves do not eliminate danger and are not a substitute for proper accident prevention measures.



Indicates an imminently hazardous situation which, if not avoided, WILL result in death or serious injury.



Indicates a potentially hazardous situation which, if not avoided, COULD result in death or serious injury.



Indicates a potentially hazardous situation which, if not avoided, MAY result in minor or moderate injury. It may also be used to alert against unsafe practices.

NOTICE

This symbol is used to alert the user to useful information about proper operation of the equipment.

WARNING

Safety Instructions for Power Tools

- KEEP GUARDS IN PLACE** and in working order.
- REMOVE ADJUSTING KEYS AND WRENCHES.** Form a habit of checking to see that keys and adjusting wrenches are removed from tool before turning on.
- KEEP WORK AREA CLEAN.** Cluttered areas and benches invite accidents.
- NEVER USE IN DANGEROUS ENVIRONMENT.** DO NOT use power tools in damp or wet locations, or where any flammable or noxious fumes may exist. Keep work area well lighted.
- KEEP CHILDREN AND VISITORS AWAY.** All children and visitors should be kept at a safe distance from work area.
- MAKE WORKSHOP CHILD PROOF** with padlocks, master switches, or by removing starter keys.
- NEVER FORCE TOOL.** It will do the job better and safer at the rate for which it was designed.
- USE RIGHT TOOL.** DO NOT force tool or attachment to do a job for which it was not designed.

⚠️ **WARNING**

Safety Instructions for Power Tools

- 9. USE PROPER EXTENSION CORD.** Make sure your extension cord is in good condition. Conductor size should be in accordance with the chart below. The amperage rating should be listed on the motor or tool nameplate. An undersized cord will cause a drop in line voltage resulting in loss of power and overheating. Your extension cord must also contain a ground wire and plug pin. Always repair or replace extension cords if they become damaged.

Minimum Gauge for Extension Cords

AMP RATING	LENGTH		
	25ft	50ft	100ft
0-6	16	16	16
7-10	16	16	14
11-12	16	16	14
13-16	14	12	12
17-20	12	12	10
21-30	10	10	No

- 10. WEAR PROPER APPAREL.** DO NOT wear loose clothing, gloves, neckties, rings, bracelets, or other jewelry which may get caught in moving parts. Non-slip footwear is recommended. Wear protective hair covering to contain long hair.
- 11. ALWAYS USE SAFETY GLASSES.** Also use face or dust mask if cutting operation is dusty. Everyday eyeglasses only have impact resistant lenses, they are NOT safety glasses.
- 12. SECURE WORK.** Use clamps or a vise to hold work when practical. It's safer than using your hand and frees both hands to operate tool.
- 13. DO NOT OVER-REACH.** Keep proper footing and balance at all times.
- 14. MAINTAIN TOOLS WITH CARE.** Keep tools sharp and clean for best and safest performance. Follow instructions for lubricating and changing accessories.

- 15. USE RECOMMENDED ACCESSORIES.** Consult the owner's manual for recommended accessories. The use of improper accessories may cause risk of injury.

- 16. REDUCE THE RISK OF UNINTENTIONAL STARTING.** On machines with magnetic contact starting switches there is a risk of starting if the machine is bumped or jarred. Always disconnect from power source before adjusting or servicing. Make sure switch is in OFF position before reconnecting.

- 17. CHECK DAMAGED PARTS.** Before further use of the tool, a guard or other part that is damaged should be carefully checked to determine that it will operate properly and perform its intended function. Check for alignment of moving parts, binding of moving parts, breakage of parts, mounting, and any other conditions that may affect its operation. A guard or other part that is damaged should be properly repaired or replaced.

- 18. NEVER LEAVE TOOL RUNNING UNATTENDED. TURN POWER OFF.** DO NOT leave tool until it comes to a complete stop.

- 19. NEVER OPERATE A MACHINE WHEN TIRED, OR UNDER THE INFLUENCE OF DRUGS OR ALCOHOL.** Full mental alertness is required at all times when running a machine.

- 20. NEVER ALLOW UNSUPERVISED OR UNTRAINED PERSONNEL TO OPERATE THE MACHINE.** Make sure any instructions you give in regards to machine operation are approved, correct, safe, and clearly understood.

- 21. IF AT ANY TIME YOU ARE EXPERIENCING DIFFICULTIES** performing the intended operation, stop using the machine! Then contact our service department or ask a qualified expert how the operation should be performed.

WARNING

Additional Safety Instructions for Sanders

- 1. BELT GUARDS.** Always use the belt guards on all sanding operations; in other words, DO NOT remove any guard!
- 2. KEEP HANDS OUTSIDE BELT GUARD.** Keep hands outside of the belt or disc guard area when sanding.
- 3. WORKPIECE CONTROL.** Make sure the workpiece is placed in a stable position on the table before sanding.
- 4. SAFETY WEAR.** Use safety glasses and a respirator to make sanding operations safe.
- 5. JAMMED WORKPIECE.** Turn OFF and Unplug the sander before clearing a jammed workpiece.
- 6. STALLED SANDER.** Turn the sander OFF before attempting to "free" a stalled workpiece.
- 7. INTERNAL ADJUSTMENTS.** Always disconnect the sander from the power source before making adjustments.
- 8. DAMAGED SANDPAPER.** Never use sandpaper that is frayed, has pleated wrinkles, or has bald spots; otherwise, serious personal injury could occur.
- 9. EXPERIENCING DIFFICULTIES.** If at any time you are experiencing difficulties performing the intended operation, stop using the sander! Contact our Service Department at (570) 546-9663 for help.

WARNING

Like all machines there is danger associated with the Model H6070. Accidents are frequently caused by lack of familiarity or failure to pay attention. Use this machine with respect and caution to lessen the possibility of operator injury. If normal safety precautions are overlooked or ignored, serious personal injury may occur.

CAUTION

No list of safety guidelines can be complete. Every shop environment is different. Always consider safety first, as it applies to your individual working conditions. Use this and other machinery with caution and respect. Failure to do so could result in serious personal injury, damage to equipment, or poor work results.

SECTION 3: CIRCUIT REQUIREMENTS

Motor Amp Draw

The following shows the amp draw for the motor when running:

Motor at 110V, Single-Phase

Amp Draw.....2.5 Amps



Grounding



! WARNING
Electrocution or a fire can result if the sander is not grounded correctly. Make sure all electrical circuits are grounded. DO NOT use the machine if it is not grounded.

In the event of an electrical short, grounding provides electric current a path of least resistance to reduce the risk of electrical shock to the operator. Ground the power cord and this machine in accordance with all local codes and ordinances and NEVER remove the grounding pin on the electrical plug. See **Figure 2**.

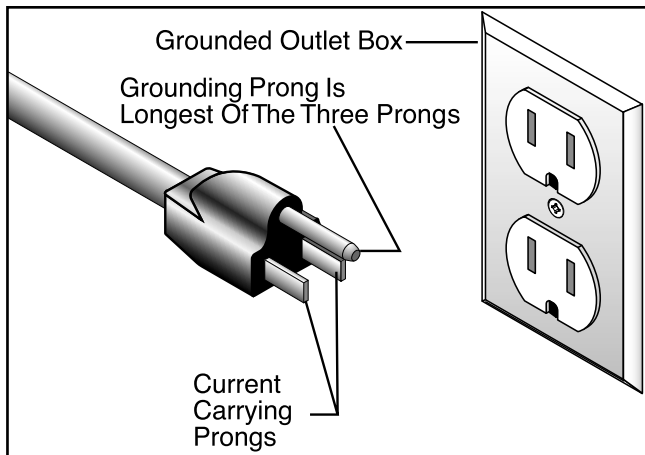

Figure 2. Three prong plug.



Circuit Breaker

Use the following guidelines when choosing a circuit breaker (circuit breakers rated any higher are not adequate to protect the circuit):

110V, Single-Phase

Circuit Breaker..... 15 Amps



Minimum Cord Size

If you need an extension cord to operate this sander, choose a cord that has a ground wire and plug pin, and meets or exceeds the minimum specifications below for safe operation. Remember, an undersized conductor causes a drop in line voltage that results in low power to the sander and an overheats the extension cord. Always repair or replace extension cords if they become damaged.

Extension Cords

- Make sure the cord is rated Standard Service (grade S) or better.
- The extension cord must also contain a ground wire and plug pin.
- Use at least a 16 gauge cord that is no longer than 100 feet!



SECTION 4: SET UP

About this Section

The purpose of this section is to guide you through the required steps to get your machine out of its packaging and into operating condition. If you are unfamiliar with the components and features, refer to "Identification" on **page 3** for a complete description of sander items.

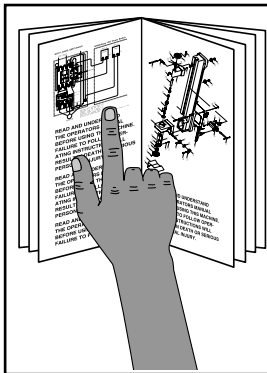
	<p>!WARNING This machine presents serious injury hazards to untrained users. Read through this entire manual to become familiar with the controls and operations before starting the machine!</p>
--	--

	<p>!WARNING Wear safety glasses during the entire set up process!</p>
---	--



Unpacking

The Model H6070 was carefully packed when it left our warehouse. If you discover the machine is damaged after you have signed for delivery, please immediately call Customer Service at (570) 546-9663 for advice.

Save the containers and all packing materials for possible inspection by the carrier or its agent. Otherwise, filing a freight claim can be difficult.

When you are completely satisfied with the condition of your shipment, you should inventory the parts.



Inventory

Use **Figure 3** and the list below to inventory the hardware and components for the Model H6070. If you have any questions, please call our customer service at (570) 546-9663.

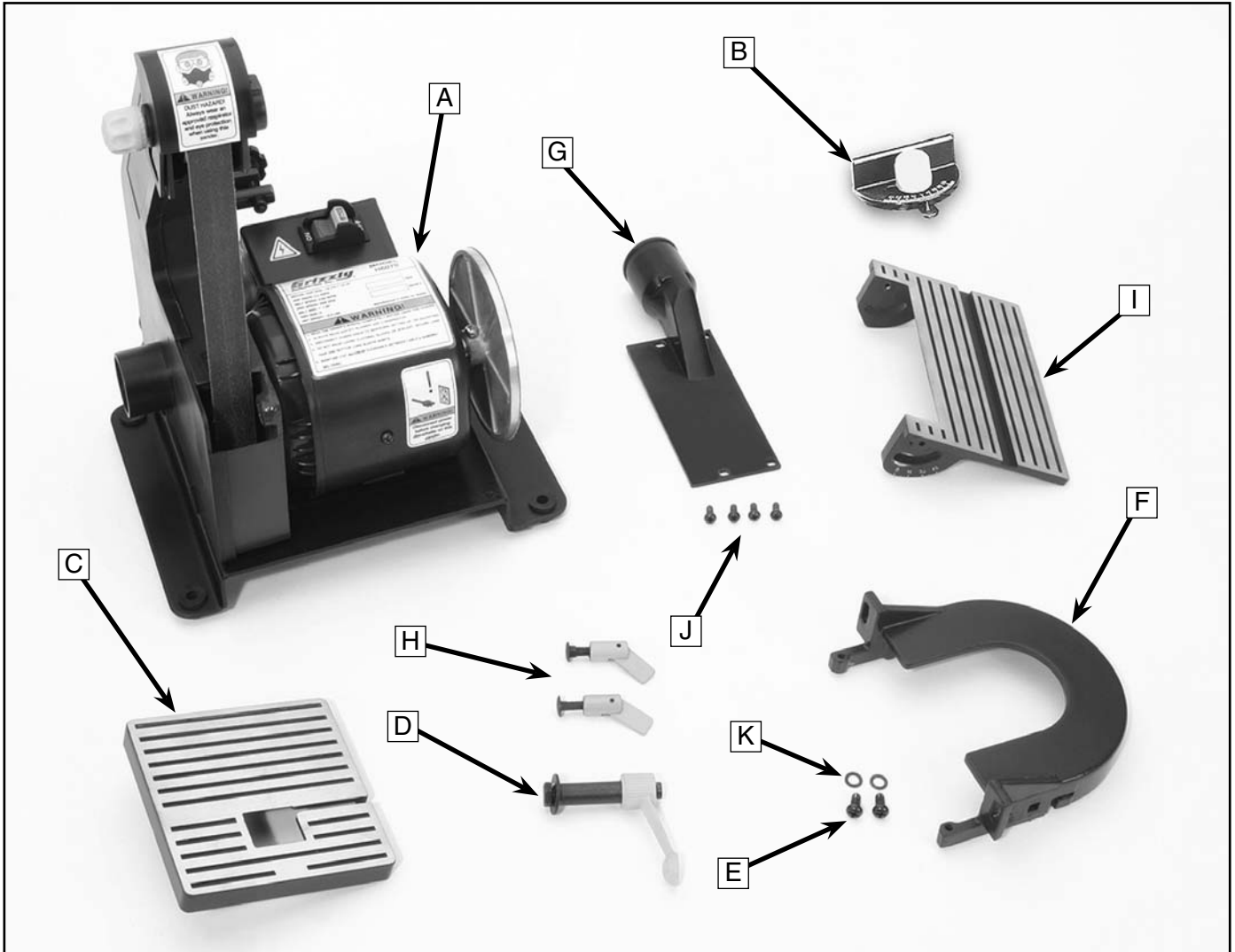

Figure 3. Model H6070 packaging inventory.







DESCRIPTION	QTY
A. Sander Assembly	1
B. Miter Gauge.....g	1
C. Sanding Belt Table.....	1
D. Sanding Belt Table Lock Lever Assembly	1
E. Sanding Disc Safety Guard Philip Head Screw M6-1.0 X 12.....	2
F. Sanding Disc Safety Guard	1
G. Sanding Disc Table Dust Chute.....	1
H. Sanding Disc Table Lock Lever Assembly.....	1
I. Sanding Disc Table	1
J. Sanding Disc Dust Chute Mounting Philip Head Screw M5-.8 X 12	4
K. Sanding Disc Dust Chute Mounting 6MM Flat Washer	2









Hardware Recognition Chart

USE THIS CHART TO MATCH UP HARDWARE DURING THE ASSEMBLY PROCESS!

MEASURE BOLT DIAMETER BY PLACING INSIDE CIRCLE

-  #10
-  1/4"
-  5/16"
-  3/8"
-  7/16"
-  1/2"

-  4mm
-  6mm
-  8mm
-  10mm
-  12mm
-  16mm

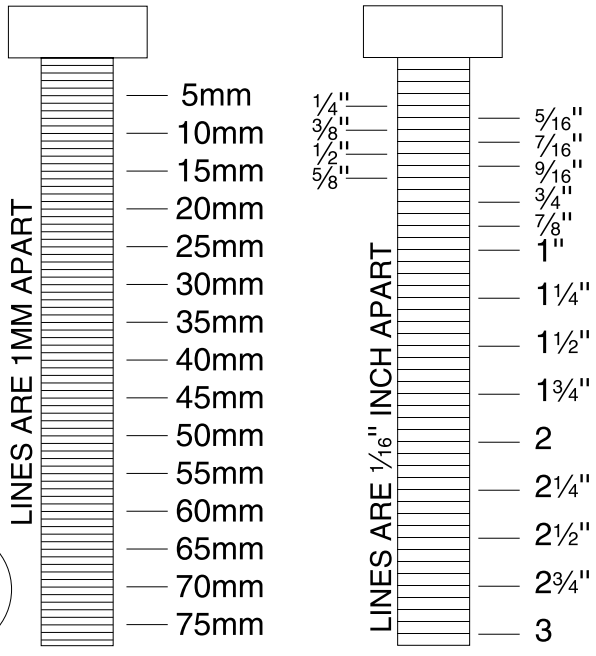
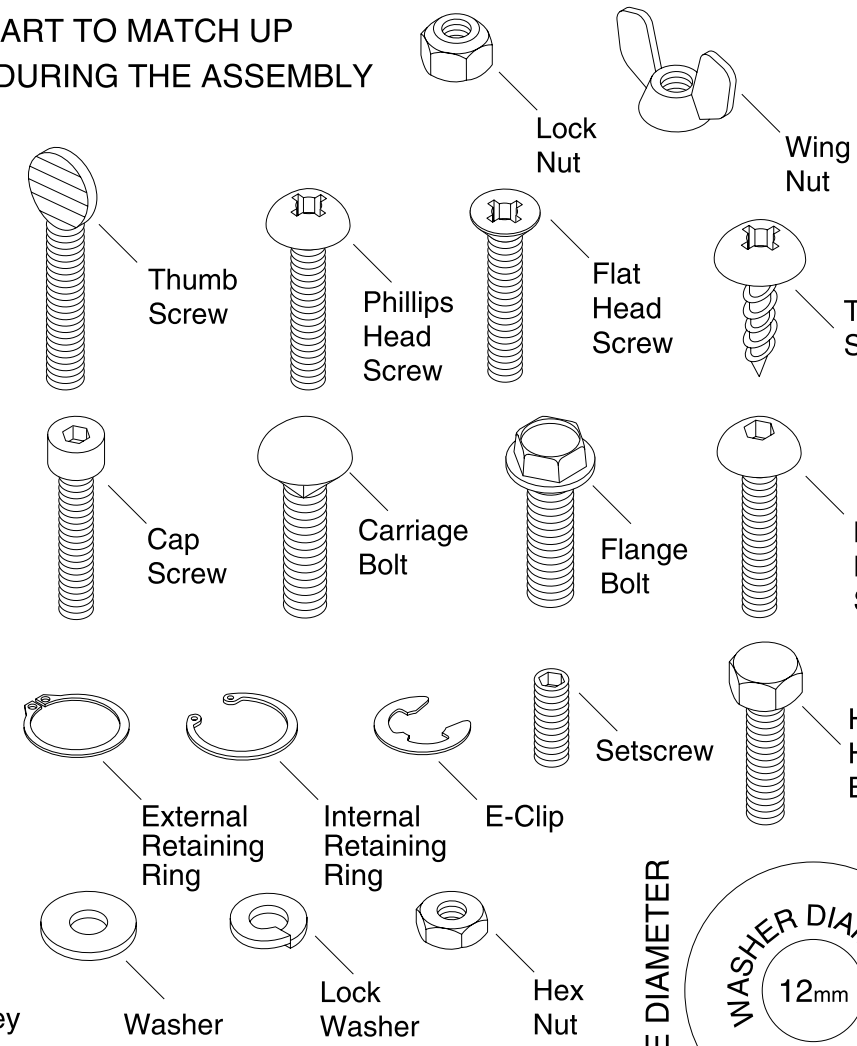

WASHERS ARE MEASURED BY THE INSIDE DIAMETER

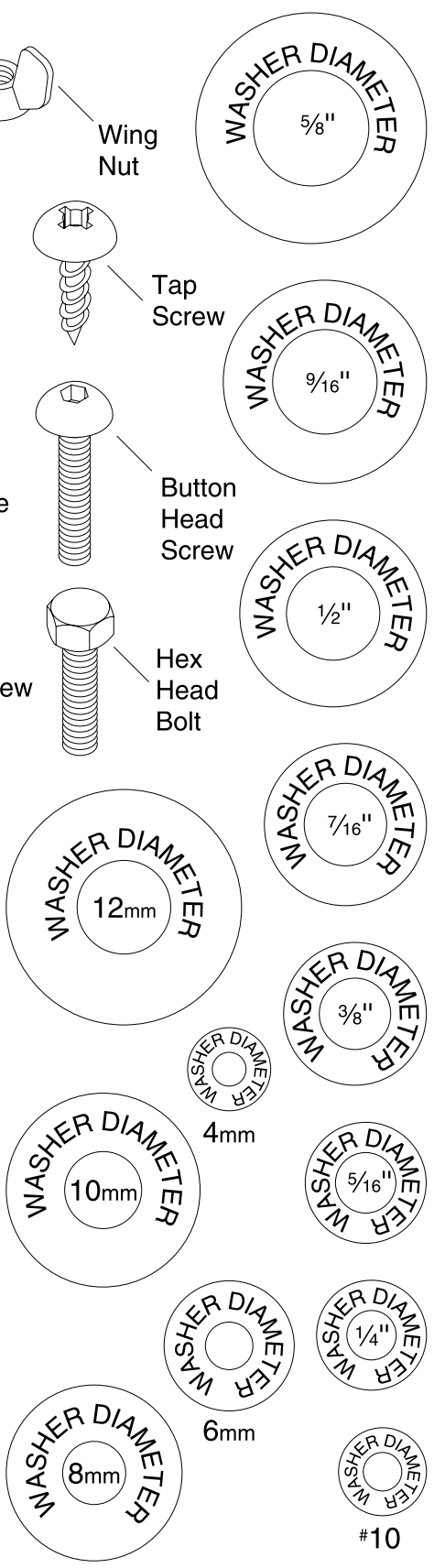

Site Considerations

Workbench and Tool Table Load Capacity

The Model H6070 weighs approximately 19 lbs. Most shop work benches and tool tables, are suitable for your new machine. Some tables or work benches may require additional reinforcement to support the combined weight of the machine and the workpiece.

Working Clearances

Consider existing and anticipated needs, size of material to be processed through each machine, and space for auxiliary stands, work tables or other machinery when establishing a location for your sander.

	<p>⚠ WARNING</p> <p>Unsupervised children and visitors inside your shop could receive serious personal injury. Ensure child and visitor safety by keeping all entrances to the shop locked at all times. DO NOT allow unsupervised children or visitors in the shop at any time.</p>
--	--



Disc Table and Guard

This sander uses a miter-slotted tilting sanding table, with a graduated degree scale that indicates the table angle. For dust collection, the safety guard also incorporates a dust port with an OD of 1¹³/₁₆" for connection to a flexible dust collection hose.

Hardware Needed:	Qty
Sanding Disc Safety Guard	1
Safety Guard Philip Head Screw M6-1 x 12	2
Safety Guard Washer 6MM.....	2
Sanding Disc Table	1
Sanding Disc Table Lock Lever Assembly.....	1
Sanding Disc Table Dust Chute	1
Dust Chute Philip Head Screw M5-0.8 x 12	4
Dust Chute Washer 5MM.....	4

Tools Needed:	Qty
Phillips #2 Screwdriver	1

To install the sanding disc table, guard, and dust chute:

1. Align the table hinge pins into the slots in the sanding disc safety guard, and install the two lock lever assemblies as shown in **Figure 4**.

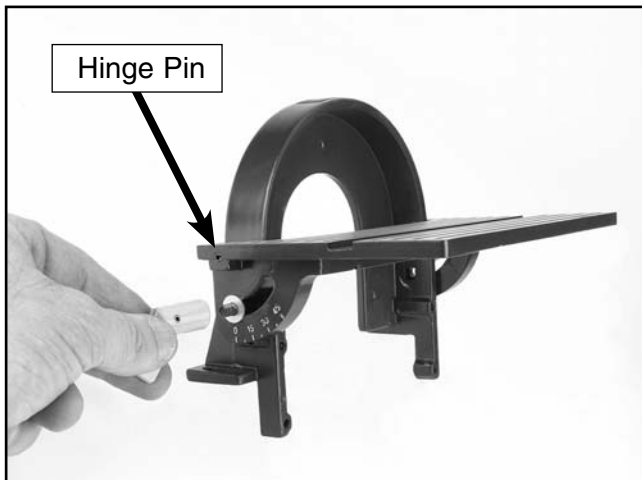

Figure 4. Disc guard and table assembly.

2. Position the safety disc guard and table onto the sander so there is a 1/16" gap between the sandpaper and the table (see **Figure 6**), and install the two screws and washers as shown in **Figure 5**.



Figure 5. Disc guard and table installation.

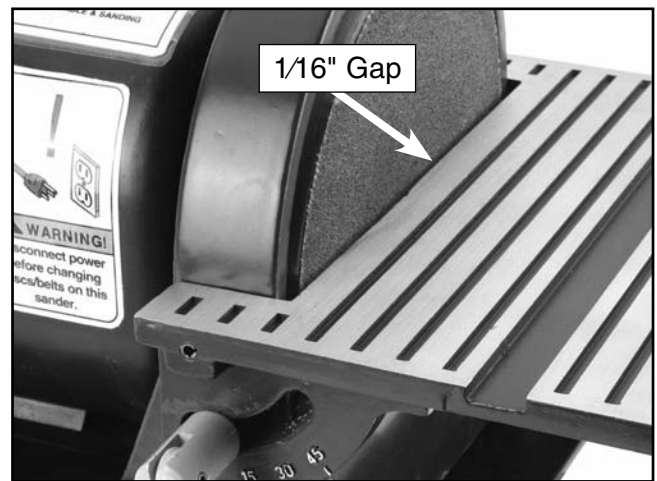

Figure 6. Sanding disc-to-table clearance.

3. Position the dust chute on the sander, and install the four screws and washers as shown in **Figure 7**.



Figure 7. Dust chute installation.



Sanding Belt Table

This sander uses a tilting sanding table with a universal positioning lock lever. For dust collection, the safety guard also incorporates a dust port with an OD of 1³/₄" for connection to flexible dust collection hose.

Hardware Needed:	Qty
Sanding Belt Table	1
Sanding Belt Table Lock Lever Assembly	1

Tools Needed:	Qty
Standard #2 Screwdriver.....	1

To install the sanding belt table:

1. If not already removed, remove the sanding belt guard as outlined in **step 2** on **page 14**.
2. Position the sanding belt table on the table support as shown in **Figure 8**.
3. Disassemble the sanding belt table lock lever and insert the square head bolt into the table support.

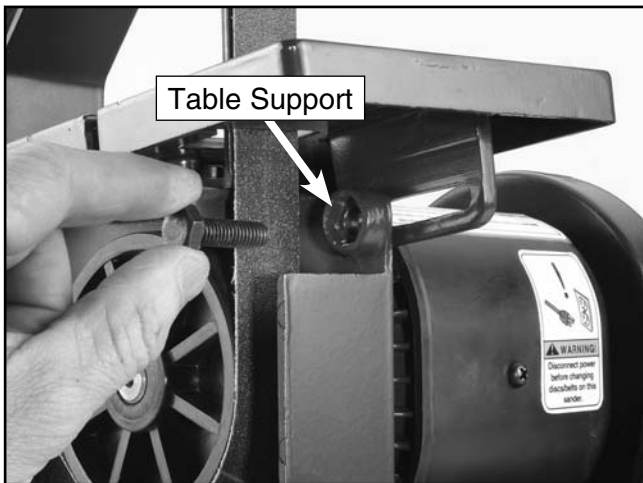

Figure 8. Lock lever square head bolt Installation.

4. Install the flat washer and thread the splined shaft onto the square head bolt as shown in **Figure 9**.

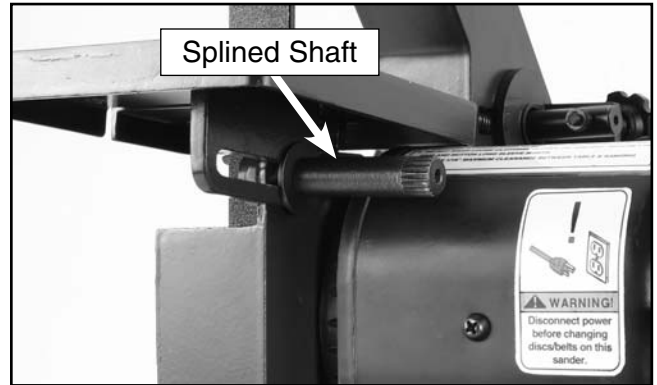

Figure 9. Splined lever shaft installed.

5. Install the universal lever so it is meshed with the splined lever shaft, and insert the spring and screw as shown in **Figure 10**.

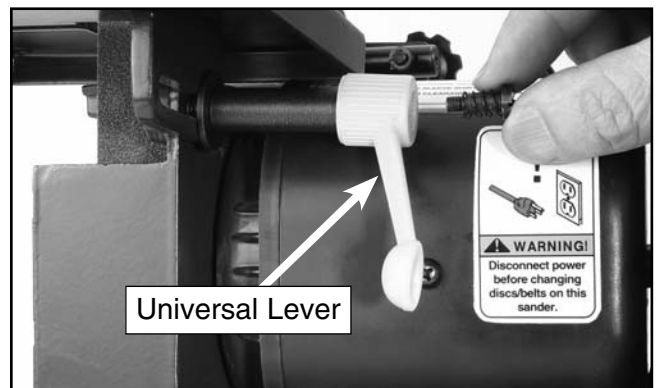

Figure 10. Lever, spring, and screw installation.

6. Tighten the screw until it is snug and the head protrudes above the lever as shown in **Figure 11**, and reinstall the belt guard.



Figure 11. Installed universal lock lever.



Sanding Belt

Sanding belt removal and installation is quick and easy, and your sander accepts an array of sanding belts that are 1" x 30." With the belt tracking knob, setting belt tracking is a snap.

Hardware Needed: Qty
Sanding Belt 1" x 30" 1

To remove and install a sanding belt:

1. **Unplug the sander!**
2. Remove the belt guard lock knob, the upper guard, and the side guard, shown in **Figure 12**.



Figure 12. Belt guards and lock knobs.

3. Rotate the sanding belt by hand and work the belt off of the wheels. If the belt is tight, you can turn the tracking knob to tilt the tracking wheel to slide the belt on and off the wheels easily.
4. Observe the rotation direction of the belt and install the belt so the arrow on the belt points the same as the arrow on the sander. See **Figure 13** for knob location.

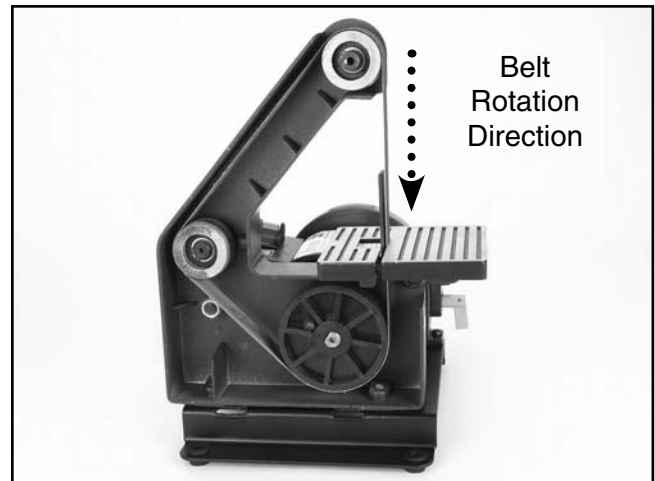

Figure 13. Sanding belt direction.

5. Rotate the belt by hand and turn the tracking knob until the belt tracks at the center of the wheels. See **Figure 14** for belt direction.

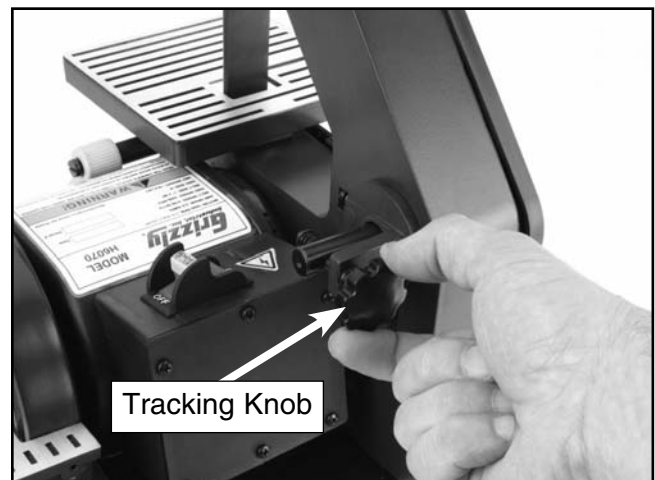

Figure 14. Setting belt tracking.

6. Reinstall both belt guards and the lock knob.
7. Make sure there is a gap of 1/16" between the backside of the sandpaper and the platen surface, and that the table is perpendicular to the platen.
 - If the gap is incorrect, refer to "Platen" on **page 18** and adjust the platen as outlined.
 - If the table is out of square with the platen, refer to "Table Squaring" on **page 18** and adjust the table as outlined.



Sanding Disc

Sanding disc removal and installation is quick and easy, and your sander accepts an array of 5" diameter self-adhesive sanding discs.

Hardware Needed: Qty
5" Self-Adhesive Sanding Disc 1

To remove and install a sanding disc:

1. **Unplug the sander!**
2. Remove the two disc guard mounting screws and washers on either side of the disc guard shown in **Figure 15**.



Figure 15. Removing disc guard and table.

3. Lift the disc guard, table, and dust chute as a complete assembly from the sander as shown in **Figure 16**.



Figure 16. Disc guard, table, and dust chute removed.

4. Peel the old sanding disc from the sanding wheel (see **Figure 17**) and clean the surface with mineral spirits and dry the surface so it is clean.



Figure 17. Sanding disc removal and Installation.

5. Carefully center the new self-adhesive disc on the sanding wheel and place the sanding disc to the wheel.
6. Reinstall the disc guard, table, and dust chute as a complete assembly onto the sander so there is a 1/16" gap between the sandpaper and the table (see **Figure 18**), and install the two screws and the washers as shown in **Figure 15**.

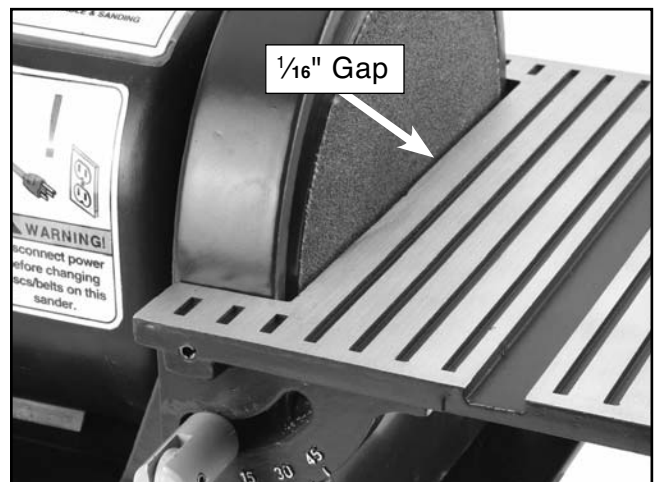

Figure 18. Sanding disc-to-table clearance.

7. Refer to "Table Squaring" on **page 18** and make sure the table is square with the sanding disc.



Belt Tracking

As you use your belt sander, the belt may begin to track off center due to wear. If this situation exists, you should adjust the tracking. The tracking knob makes setting belt tracking quick and easy.

To adjust the sanding belt tracking:

1. **Unplug the sander!**
2. Remove the belt guard lock knob, the upper guard, and the side guard shown in **Figure 19**.



Figure 19. Belt covers.

3. Rotate the belt by hand and observe the tracking position. The belt should track at the center of all the wheels.
 - If the sanding belt tracks off-center to the left as you are looking at the front of the sander, rotate the tracking knob (see **Figure 20**) counterclockwise until the belt tracks to the center.
 - If the sanding belt tracks off-center to the right, rotate the tracking knob clockwise until the belt tracks to the center.

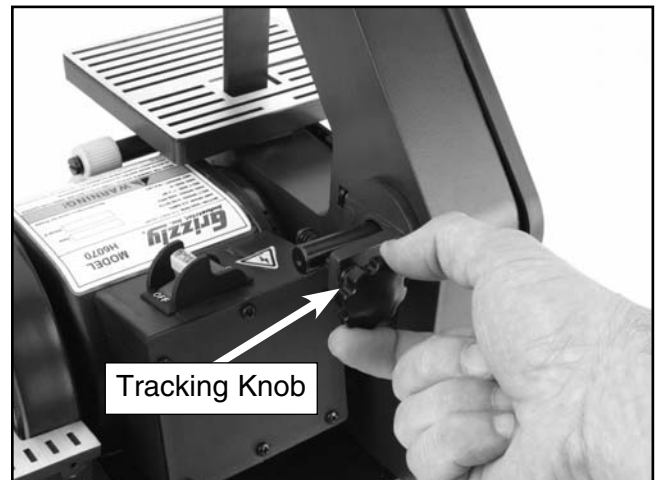

Figure 20. Setting the belt tracking (rear view).

4. Reinstall the belt guards and plug in the sander.
5. Quickly flip the power switch ON then OFF so you can observe where the belt is tracking at high speed, and fine-tune the tracking with the knob as required.



Platen

The platen acts as a surface to sand against. This platen is adjustable and should have gap of $\frac{1}{16}$ " between the sandpaper and the platen. At times you may find it useful to remove the platen for polishing or contour sanding.

Tools Needed: Qty
Hex Wrench 3mm..... 1

To adjust or remove the platen:

1. **Unplug the sander!**
2. Loosen the table lock lever and tilt the table forward for access to the platen cap screws shown in **Figure 21**.

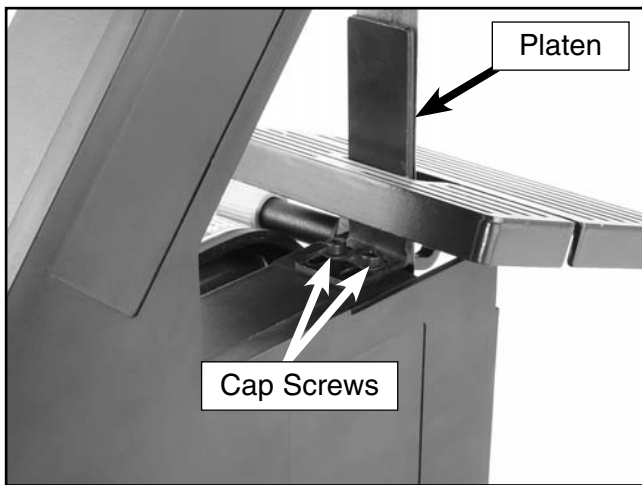

Figure 21. Platen and cap screws.

- If you need to polish or contour sand, remove the cap screws, washers, and platen.
- If you need to set the platen-to-belt clearance, loosen the cap screws, and move the platen to get $\frac{1}{16}$ " between the platen and the belt, and retighten the cap screws.

3. Refer to "Table Squaring" on this page, and adjust the table as outlined to make it square or perpendicular with the platen.



Table Squaring

For best results when maintaining perpendicular sanding, keep a combination square close at hand. This tool will serve as a quick way to zero the table 90° to the sanding surface.

Tools Needed: Qty
Small Combination Square..... 1

To square the tables to the platen or sanding disc:

1. **Unplug the sander!**
2. Loosen the table lock lever(s) and use the combination square to square the table to the platen or the table to the disc as shown in **Figures 22** and **23**.

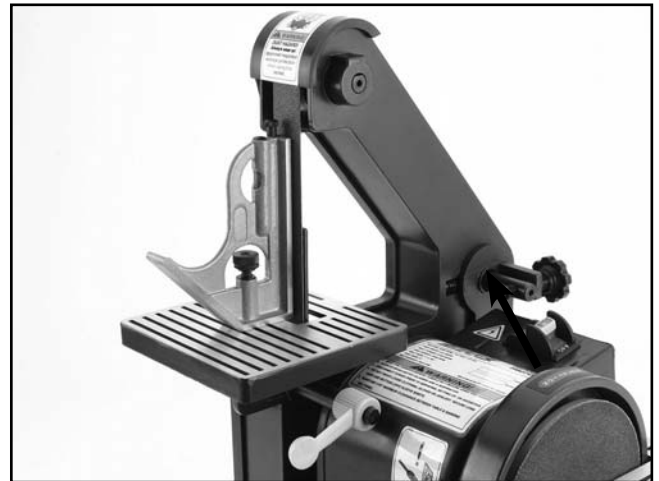

Figure 22. Squaring table to platen.

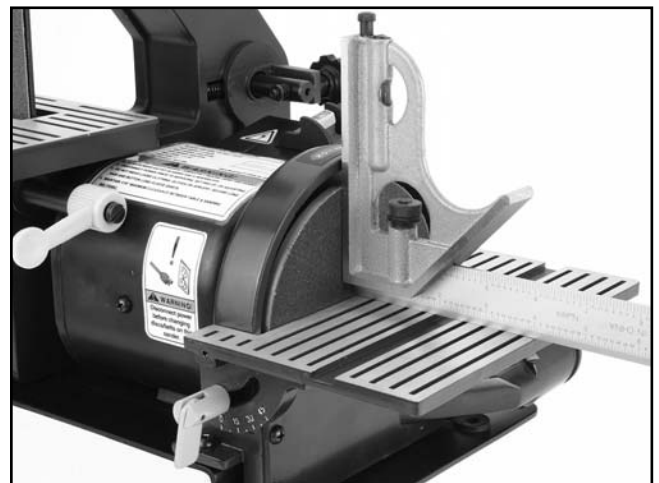

Figure 23. Squaring table to disc.



Mounting

This sander must be installed to a horizontal mounting surface like a sturdy workbench or tool table for sanding control and safety. The Model H6070 weighs approximately 19 lbs. and is equipped with four rubber feet, which act as insulators and shock absorbers to reduce any vibration during operation. Review "Site Considerations" on **page 12** for additional basic information.

⚠ WARNING

ONLY operate this sander when it is securely mounted to a sturdy surface. Otherwise, the sander can flip and injure you.

Hardware Needed:	Qty
Hex Bolt 3/8"-16 x Mounting Thickness.....	8
Lock Washer 3/8".....	4
Flat Washer 3/8".....	8
Hex Nut 3/8"-16.....	8

Tools Needed:	Qty
Electric Drill.....	1
Drill Bit 3/8".....	1
Wrench 3/8".....	2
Pencil.....	1

To mount the sander to a workbench or tool table:

- 1. Unplug the sander!**
- 2.** Set the sander on the mounting surface, and mark the hole location.
- 3.** Drill four mounting holes through the mounting surface, and set the sander rubber feet over the mounting holes.

- 4.** Install all mounting hardware in the order as shown in **Figure 24**, and tighten the compression nuts just until the rubber feet start to swell slightly.
- 5.** Tighten the jam nuts against the compression nuts.
 - If the workbench or tool table vibrates during sander use, stabilize the workbench or tool table with shims or adjust the feet.

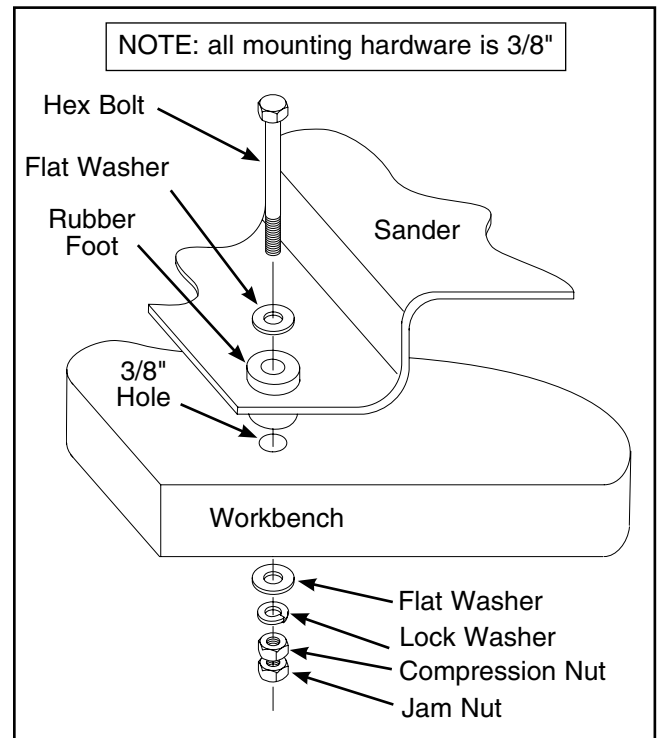

Figure 24. Sander mounting layout.



SECTION 5: OPERATIONS

Safe Operation

Your safety is important. Please review Section 2: Safety before operating this saw. The operator is ultimately responsible for his/her own safety, as well as the safety of bystanders. Every sanding operation is uniquely different and no amount of safety instructions can replace good common sense and a properly adjusted machine.

!WARNING

Damage to your eyes and lungs could result from using this machine without proper protective gear. Always wear safety glasses and a respirator when operating this machine.

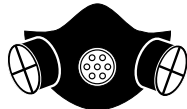

!WARNING

Loose hair and clothing could get caught in machinery and cause serious personal injury. Keep loose clothing and long hair away from moving machinery.

NOTICE

The following section was designed to give instructions on the basic operations of this machine. However, it is in no way comprehensive of all of the machine's applications. **WE STRONGLY RECOMMEND** that you read books, trade magazines, or get formal training to maximize the potential of your machine.



Starting the Sander

!WARNING

ONLY operate this sander when it is securely mounted to a sturdy surface. Otherwise, the sander can flip over and injure you.

To start the sander:

1. Once the sander is assembled and adjusted properly, insert the safety lockout key (see **Figure 25**) and plug the sander in.



Figure 25. Inserting/removing safety key.

2. Turn the sander ON, and listen and observe for any abnormal noise or vibration.
 - If the sander has an abnormal noise or vibration, immediately turn the machine OFF, unplug it, and investigate and correct the problem. Refer to "Troubleshooting" on **page 24** for common problems and solutions.
 - If the sander operates fine, refer to the following pages for basic sanding operations:
 - Disc End-Sanding, **page 21**.
 - Belt End-Sanding, **page 21**.
 - Contour Sanding, **page 22**.
 - Chisel Sharpening, **page 22**.



Disc End-Sanding

With the Model H6070, you can sand the end of a workpiece at a chosen angle. The angle is achieved by tilting the disc table or using the miter gauge.

To sand the end of a workpiece with the abrasive disc:

1. Review the "Safe Operation" warnings on **page 20**, and take the necessary steps.

⚠ WARNING

NEVER feed the workpiece into the disc at the right side of the disc. The disc will grab the workpiece causing chatter, vibration, and possible injury to you.

2. Turn the sander ON, and recognize the direction of rotation.
3. Slowly feed the workpiece into the left side of the disc as shown in **Figure 26** so the workpiece does not chatter or vibrate.



Figure 26. Disc rotation and workpiece position.



Belt End-Sanding

With the Model H6070, you can sand the end of a workpiece at a chosen angle. The angle is achieved by tilting the belt table.

To sand the end of a workpiece with the abrasive belt:

1. Review the "Safe Operation" warnings on **page 20**, and take the necessary steps.
2. Make sure the platen is in place and the table-to-platen angle is at the desired degree.
3. Turn the sander ON, and slowly feed the workpiece into the sanding belt, as shown in **Figure 27**, so the workpiece does not chatter or vibrate.

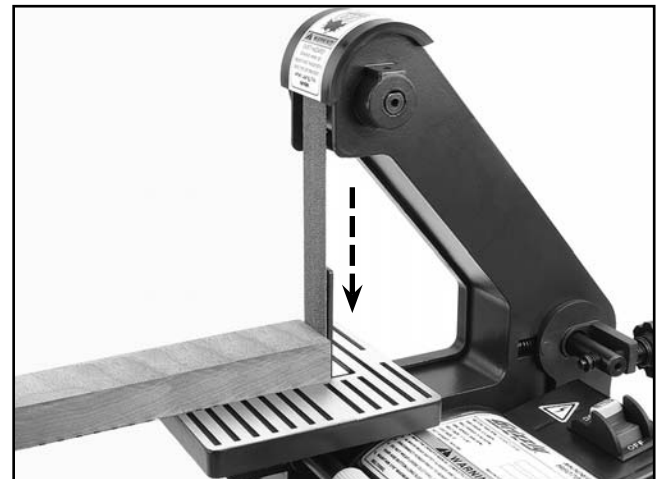

Figure 27. Belt rotation and workpiece position.



Contour Sanding

With the Model H6070, you can contour sand or polish a workpiece. With the backstop removed, the sanding belt will conform to a curved edge for sanding or polishing.

To contour or polish the end of a workpiece with the abrasive belt:

1. Review the "Safe Operation" warnings on **page 20**, and take the necessary steps.
2. Remove the platen.
3. Turn the sander ON, and slowly feed the workpiece into the sanding belt as shown in **Figure 28**, so the workpiece does not chatter or vibrate.



Figure 28. Contour sanding/polishing, and belt direction.



Chisel Sharpening

With the Model H6070, you can also sharpen your shop chisels. You will need to make a false table out of wood for safety.

To sharpen a chisel with the abrasive belt:

1. Review the "Safe Operation" warnings on **page 20**, and take the necessary steps.
2. Tilt the sanding belt table to the angle needed for sharpening.

!WARNING

When the table is tilted, NEVER attempt to sharpen chisels or any other tool without using a false table covering the large gap between the table and belt. Otherwise, the gap is too large and the chisel could be pulled into the sander causing severe injury.

3. Make a false table and clamp it to the sanding table with a 1/16" gap between the false table and the belt.
4. Turn the sander ON, and slowly feed the chisel into the sanding belt as shown in **Figure 29**, so the chisel does not chatter, vibrate, or grab and tear the belt.

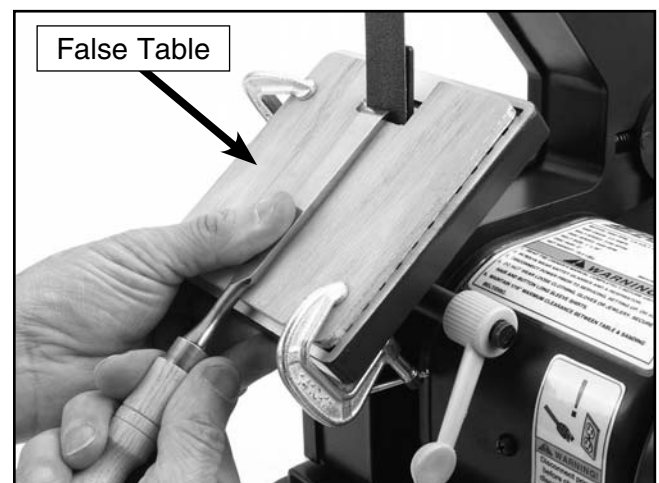

Figure 29. Chisel sharpening.



SECTION 6: MAINTENANCE

Schedule

No lubrication is required for this sander. All bearings are sealed and permanently lubricated.

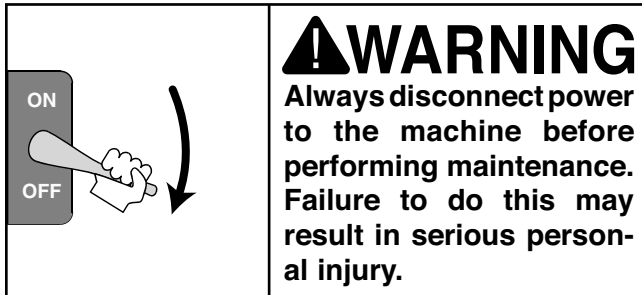

Pre-use Check:

- Loose mounting bolts.
- Loose tables, lock levers, platen, or bolts.
- Loose or missing safety guards.
- Damaged abrasive belt or disc.
- Worn or damaged wires.
- Plug condition.
- Any other condition unsafe condition.



Troubleshooting

Symptom	Possible Cause	Possible Solution
Sander will not start; fuses or circuit breakers trip.	<ol style="list-style-type: none"> 1. Low voltage or tripped circuit breaker. 2. Loose or open wire. 3. Start capacitor is at fault. 4. Motor is at fault. 	<ol style="list-style-type: none"> 1. Check power supply for proper voltage, and repair for cause of tripped circuit breaker. 2. Inspect all lead connections on motor for loose or open connections. 3. Replace start capacitor. 4. Replace motor.
Sander fails to develop full power, output of motor decreases rapidly with decrease in voltage at motor terminals.	<ol style="list-style-type: none"> 1. Power line overloaded with lights, appliances, and other motors. 2. Undersized wires or circuits too long. 3. General overloading of power company facilities. 	<ol style="list-style-type: none"> 1. Reduce load on power line. 2. Increase wire sizes or reduce length of wire. 3. Request a power check from the power company.
Motor overheats.	<ol style="list-style-type: none"> 1. Motor overloaded. 2. Air circulation through the motor restricted. 	<ol style="list-style-type: none"> 1. Reduce load on motor. 2. Clean out motor to provide normal air circulation.
Sander stalls (resulting in blown fuses or tripped circuit).	<ol style="list-style-type: none"> 1. Short circuit in motor or loose connections. 2. Incorrect fuses or circuit breakers in power line. 3. Motor overloaded. 	<ol style="list-style-type: none"> 1. Repair or replace connections on motor for loose or shorted terminals or worn insulation. 2. Install correct fuses or circuit breakers. 3. Reduce load on motor.
Sander vibrates.	<ol style="list-style-type: none"> 1. Rubber feet worn or loose mounting. 2. Table or workbench is not level or is not sitting flat on the floor. 3. Worn bearings. 	<ol style="list-style-type: none"> 1. Replace the rubber feet, tighten the mounting bolts. 2. Shim or adjust the feet. 3. Replace bearings.



H6070 Parts Breakdown

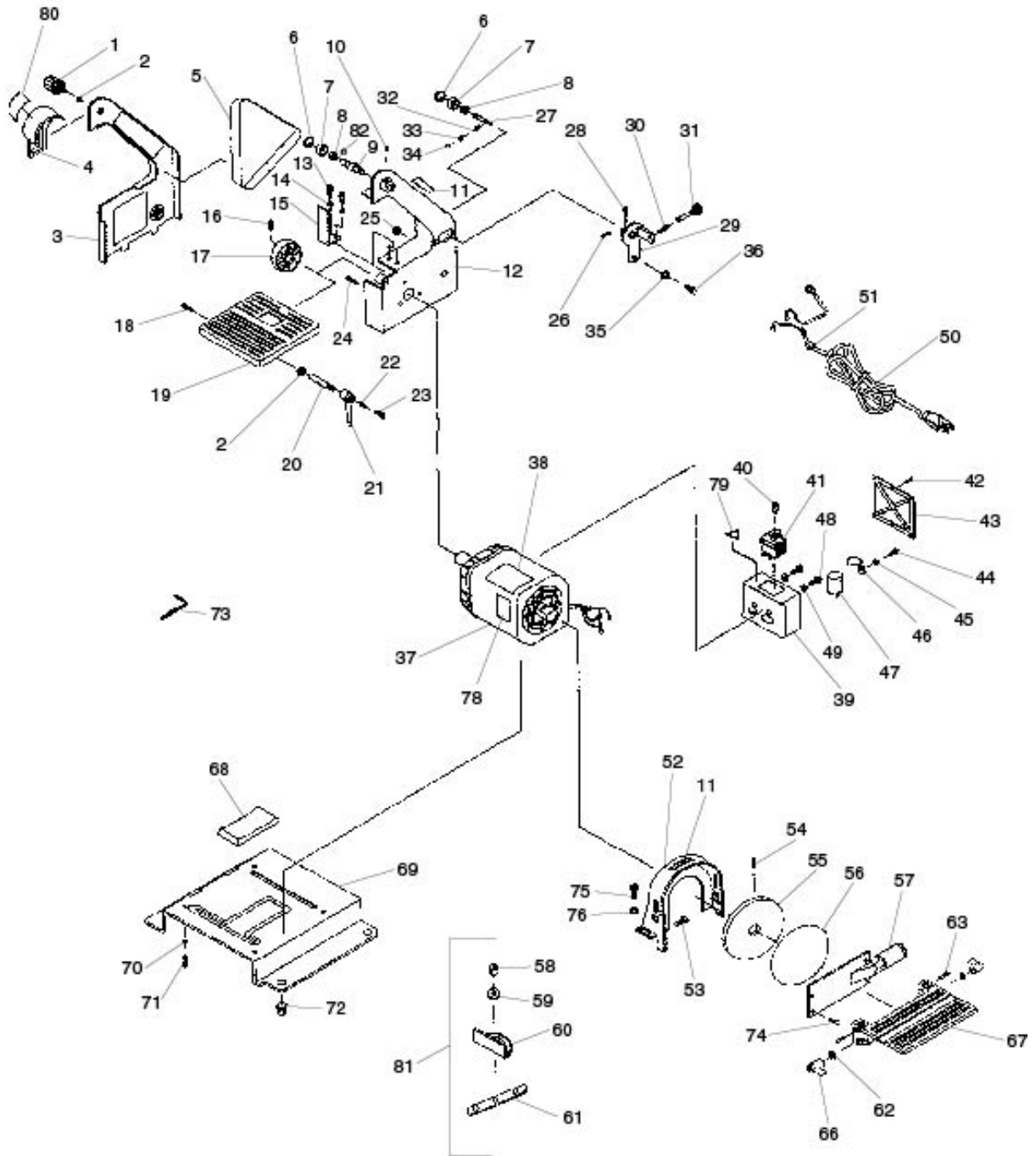

H6070

REF	PART #	DESCRIPTION
1	PH6070001	KNOB BOLT M8-1.25 X 16
2	PW01M	FLAT WASHER 8MM
3	PH6070003	BELT SAFETY COVER (LARGE)
4	PH6070004	BELT SAFETY COVER (SMALL)
5	H4858	SANDING BELT 1" X 30" 80-GRIT
6	PR02M	EXT RETAINING RING 14MM
7	PH6070007	WHEEL
8	P6202	BEARING 6202 2RZ
9	PH6070009	SHAFT
10	PSS01M	SET SCREW M6-1 X 10
11	PH6070011	ROTATION LABEL
12	PH6070012	BELT GUARD
13	PSB23M	CAP SCREW M4-.7 X 12
14	PLW02M	LOCK WASHER 4MM
15	PH6070015	PLATEN
16	PSB26M	CAP SCREW M6-1.0 X 12
17	PH6070017	WHEEL
18	PB07M	HEX BOLT M8-1.25 X 25
19	PH6070019	TABLE
20	PH6070020	SPLINED LEVER SHAFT
21	PH6070021	LEVER HANDLE
22	PH6070022	SPRING .08 X 7 X 10MM
23	PH6070023	SPECIAL SCREW
24	PFH02M	FLAT HD SCR M6-1.0 X 12
25	PLN05M	LOCK NUT M10-1.5
26	PH6070026	SPRING 1.4 X 8 X 35MM
27	PH6070027	BELT TENSION SHAFT
28	PRP20M	ROLL PIN 4 X 22MM
29	PH6070029	BELT TENSION BRACKET
30	PH6070030	SPRING 1 X 10 X 18MM
31	PH6070031	TRACKING KNOB ASSEMBLY
32	PH6070032	SPRING .8 X 7 X 13MM
33	PW02M	FLAT WASHER 5MM
34	PH6070034	SPECIAL WASHER
35	PW04M	FLAT WASHER 10MM
36	PB01M	HEX BOLT M10-1.5 X 30
37	PH6070037	MOTOR
38	PH6070038	DATA LABEL
39	PH6070039	WIRING BOX

REF	PART #	DESCRIPTION
40	PH6070040	SWITCH SAFETY KEY
41	PH6070041	SWITCH
42	PHTEK8	TAP SCREW #8 X 1/2"
43	PH6070043	WIRING BOX COVER
44	PS08M	PHLP HD SCR M5-.8 X 12
45	PW02M	FLAT WASHER 5MM
46	PH6070046	CAPACITOR STRAP
47	PH6070047	CAPACITOR 16MFD/250VAC
48	PS08M	PHLP HD SCR M5-.8 X 12
49	PW02M	FLAT WASHER 5MM
50	PH6070050	18-AWG 7' POWER CBL/W PLUG
51	PH6070051	STRAIN RELIEF
52	PH6070052	DISC SAFETY COVER
53	PH6070053	SQUARE HD BOLT M6-1.0 X 25
54	PS26M	PHLP HD SCR M6-1.0 X 20
55	PH6070055	ALUMINUM DISC
56	G3699	5" PSA SANDING DISC 80 GRIT
57	PH6070057	DUST CHUTE ASSEMBLY
58	PH6070058	MITER KNOB BOLT M6-1.0 X 10
59	PW03M	FLAT WASHER 6MM
60	PH6070060	MITER HOUSING
61	PH6070061	MITER BAR ASSEMBLY
62	PW03M	FLAT WASHER 6MM
63	PRP39M	ROLL PIN 4 X 20MM
66	PH6070066	LEVER ASSEMBLY
67	PH6070067	TABLE
68	PH6070068	RUBBER MOTOR SEAT
69	PH6070069	BASE PLATE
70	PLW04M	LOCK WASHER 8MM
71	PB09M	HEX BOLT M8-1.25 X 20
72	PH6070072	RUBBER FOOT
73	PAW03M	HEX WRENCH 3MM
74	PS23M	PHLP HD SCR M5-.8 X 12
75	PS14M	PHLP HD SCR M6-1 X 12
76	PW03M	FLAT WASHER 6MM
78	PH6070078	UNPLUG 110V LABEL
79	PH6070079	ELECTRICAL WARNING
80	PH6070080	DUST/GOGGLES WARNING
81	PH6070081	COMPLETE MITER ASSEMBLY
82	PH6070082	INT RETAINING RING 36MM

H6070 Wiring Diagram

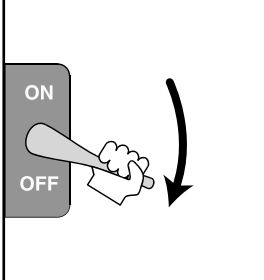
	<p>⚠ DANGER</p> <p>Always disconnect power to the sander before you perform any electrical work. Otherwise serious injury or death could occur!</p>
---	--

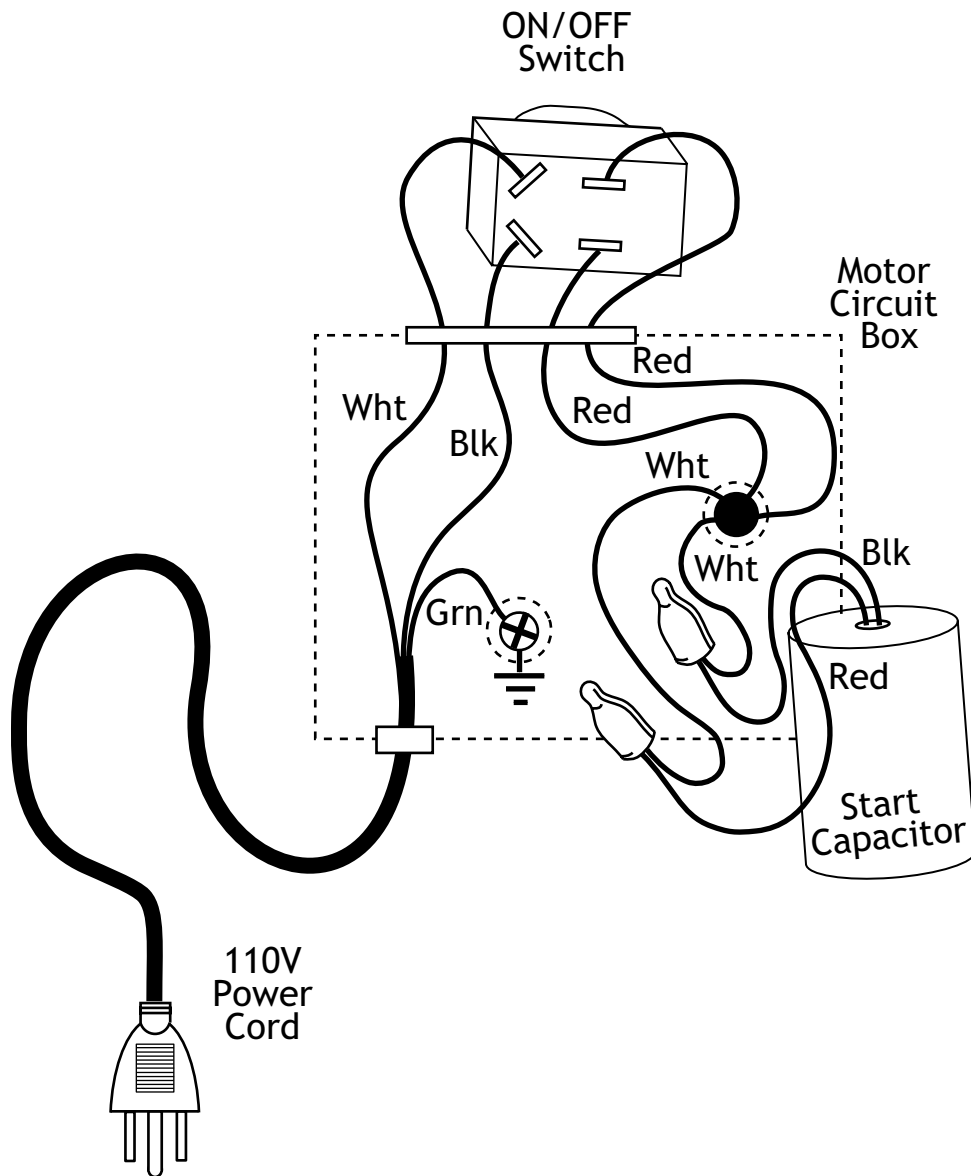

Warranty & Returns

Grizzly Industrial, Inc. warrants every product it sells for a period of 1 year to the original purchaser from the date of purchase. This warranty does not apply to defects due directly or indirectly to misuse, abuse, negligence, accidents, repairs or alterations or lack of maintenance. This is Grizzly's sole written warranty and any and all warranties that may be implied by law, including any merchantability or fitness, for any particular purpose, are hereby limited to the duration of this written warranty. We do not warrant or represent that the merchandise complies with the provisions of any law or acts unless the manufacturer so warrants. In no event shall Grizzly's liability under this warranty exceed the purchase price paid for the product and any legal actions brought against Grizzly shall be tried in the State of Washington, County of Whatcom.

We shall in no event be liable for death, injuries to persons or property or for incidental, contingent, special, or consequential damages arising from the use of our products.

To take advantage of this warranty, contact us by mail or phone and give us all the details. We will then issue you a "Return Number," which must be clearly posted on the outside as well as the inside of the carton. We will not accept any item back without this number. Proof of purchase must accompany the merchandise.

The manufacturers reserve the right to change specifications at any time because they constantly strive to achieve better quality equipment. We make every effort to ensure that our products meet high quality and durability standards and we hope you never need to use this warranty.

Please feel free to write or call us if you have any questions about the machine or the manual.

Thank you again for your business and continued support. We hope to serve you again soon.



WARRANTY CARD

Name _____
 Street _____
 City _____ State _____ Zip _____
 Phone Number _____ E-Mail _____ FAX _____
MODEL # _____ **Serial #** _____ **Order #** _____

The following information is given on a voluntary basis. It will be used for marketing purposes to help us develop better products and services. Of course, all information is strictly confidential.

CUT ALONG DOTTED LINE

- | | | | | | | | | | | | | | | | | | | | | | | | | | | | | | | | | | | | | | | | | | | | | | | | | | | | | | | | | | | | | | | | | | | | | | | | | | | | | | | | | | | | | | | | | | | | | | | | | | | | | | |
|---|---|--|---------------------------------------|-------------------------------|--|--------------------------------------|--|--|--|------------------------------------|--|-----------------------------------|--|-------------------------------------|--|---|--|------------------------------------|--|--|--------------------------------------|--|---|--|------------------------------------|---|--|--|--------------------------------------|--|--|--|--|--|--|--|--|--|--------------------------------|--------------------------------|--------------------------------|--------------------------------|--------------------------------|------------------------------------|--------------------------------------|---------------------------------------|--------------------------------------|------------------------------------|---------------------------------|-----------------------------------|---------------------------------------|---|---|------------------------------------|---------------------------------|---------------------------------|--------------------------------------|---------------------------------------|--------------------------------------|---|---|---------------------------------|--|---|----------------------------------|------------------------------------|--------------------------------|--|-----------------------------------|---|--------------------------------------|--|---|---|--|--|-------------------------------------|---------------------------------------|---|--|-------------------------------------|---|--|---------------------------------------|--|--------------------------------------|--|--------------------------------------|---|---|--------------------------------------|---------------------------------------|--|--|------------------------------------|---------------------------------------|--|------------------------------------|---------------------------------|--------------------------------------|--|
| <p>1. How did you learn about us?</p> <p> <input type="checkbox"/> Advertisement <input type="checkbox"/> Friend
 <input type="checkbox"/> Catalog <input type="checkbox"/> Card Deck
 <input type="checkbox"/> World Wide Web
 <input type="checkbox"/> Other _____ </p> <p>2. Which of the following magazines do you subscribe to.</p> <table border="0" style="width: 100%;"> <tr> <td><input type="checkbox"/> American How-To</td> <td><input type="checkbox"/> Today's Homeowner</td> </tr> <tr> <td><input type="checkbox"/> Cabinetmaker</td> <td><input type="checkbox"/> WOOD</td> </tr> <tr> <td><input type="checkbox"/> Family Handyman</td> <td><input type="checkbox"/> Wooden Boat</td> </tr> <tr> <td><input type="checkbox"/> Fine Homebuilding</td> <td><input type="checkbox"/> Woodshop News</td> </tr> <tr> <td><input type="checkbox"/> Home Handyman</td> <td><input type="checkbox"/> Woodsmith</td> </tr> <tr> <td><input type="checkbox"/> Journal of Light Construction</td> <td><input type="checkbox"/> Woodwork</td> </tr> <tr> <td><input type="checkbox"/> Old House Journal</td> <td><input type="checkbox"/> Woodworker</td> </tr> <tr> <td><input type="checkbox"/> Popular Mechanics</td> <td><input type="checkbox"/> Woodworker's Journal</td> </tr> <tr> <td><input type="checkbox"/> Popular Science</td> <td><input type="checkbox"/> Workbench</td> </tr> <tr> <td><input type="checkbox"/> Popular Woodworking</td> <td></td> </tr> <tr> <td><input type="checkbox"/> Other _____</td> <td></td> </tr> </table> <p>3. Which of the following woodworking/remodeling shows do you watch?</p> <table border="0" style="width: 100%;"> <tr> <td><input type="checkbox"/> Backyard America</td> <td><input type="checkbox"/> The New Yankee Workshop</td> </tr> <tr> <td><input type="checkbox"/> Home Time</td> <td><input type="checkbox"/> This Old House</td> </tr> <tr> <td><input type="checkbox"/> The American Woodworker</td> <td><input type="checkbox"/> Woodwright's Shop</td> </tr> <tr> <td><input type="checkbox"/> Other _____</td> <td></td> </tr> </table> <p>4. What is your annual household income?</p> <table border="0" style="width: 100%;"> <tr> <td><input type="checkbox"/> \$20,000-\$29,999</td> <td><input type="checkbox"/> \$60,000-\$69,999</td> </tr> <tr> <td><input type="checkbox"/> \$30,000-\$39,999</td> <td><input type="checkbox"/> \$70,000-\$79,999</td> </tr> <tr> <td><input type="checkbox"/> \$40,000-\$49,999</td> <td><input type="checkbox"/> \$80,000-\$89,999</td> </tr> <tr> <td><input type="checkbox"/> \$50,000-\$59,999</td> <td><input type="checkbox"/> \$90,000 & over</td> </tr> </table> <p>5. What is your age group?</p> <table border="0" style="width: 100%;"> <tr> <td><input type="checkbox"/> 20-29</td> <td><input type="checkbox"/> 50-59</td> </tr> <tr> <td><input type="checkbox"/> 30-39</td> <td><input type="checkbox"/> 60-69</td> </tr> <tr> <td><input type="checkbox"/> 40-49</td> <td><input type="checkbox"/> 70 & over</td> </tr> </table> <p>6. How long have you been a woodworker?</p> <table border="0" style="width: 100%;"> <tr> <td><input type="checkbox"/> 0 - 2 Years</td> <td><input type="checkbox"/> 8 - 20 Years</td> </tr> <tr> <td><input type="checkbox"/> 2 - 8 Years</td> <td><input type="checkbox"/> 20+ Years</td> </tr> </table> <p>7. How would you rank your woodworking skills?</p> <table border="0" style="width: 100%;"> <tr> <td><input type="checkbox"/> Simple</td> <td><input type="checkbox"/> Advanced</td> </tr> <tr> <td><input type="checkbox"/> Intermediate</td> <td><input type="checkbox"/> Master Craftsman</td> </tr> </table> <p>8. What stationary woodworking tools do you own? Check all that apply.</p> <table border="0" style="width: 100%;"> <tr> <td><input type="checkbox"/> Air Compressor</td> <td><input type="checkbox"/> Panel Saw</td> </tr> <tr> <td><input type="checkbox"/> Sander</td> <td><input type="checkbox"/> Planer</td> </tr> <tr> <td><input type="checkbox"/> Drill Press</td> <td><input type="checkbox"/> Power Feeder</td> </tr> <tr> <td><input type="checkbox"/> Drum Sander</td> <td><input type="checkbox"/> Radial Arm Saw</td> </tr> <tr> <td><input type="checkbox"/> Dust Collector</td> <td><input type="checkbox"/> Shaper</td> </tr> <tr> <td><input type="checkbox"/> Horizontal Boring Machine</td> <td><input type="checkbox"/> Spindle Sander</td> </tr> <tr> <td><input type="checkbox"/> Jointer</td> <td><input type="checkbox"/> Table Saw</td> </tr> <tr> <td><input type="checkbox"/> Lathe</td> <td><input type="checkbox"/> Vacuum Veneer Press</td> </tr> <tr> <td><input type="checkbox"/> Mortiser</td> <td><input type="checkbox"/> Wide Belt Sander</td> </tr> <tr> <td><input type="checkbox"/> Other _____</td> <td></td> </tr> </table> | <input type="checkbox"/> American How-To | <input type="checkbox"/> Today's Homeowner | <input type="checkbox"/> Cabinetmaker | <input type="checkbox"/> WOOD | <input type="checkbox"/> Family Handyman | <input type="checkbox"/> Wooden Boat | <input type="checkbox"/> Fine Homebuilding | <input type="checkbox"/> Woodshop News | <input type="checkbox"/> Home Handyman | <input type="checkbox"/> Woodsmith | <input type="checkbox"/> Journal of Light Construction | <input type="checkbox"/> Woodwork | <input type="checkbox"/> Old House Journal | <input type="checkbox"/> Woodworker | <input type="checkbox"/> Popular Mechanics | <input type="checkbox"/> Woodworker's Journal | <input type="checkbox"/> Popular Science | <input type="checkbox"/> Workbench | <input type="checkbox"/> Popular Woodworking | | <input type="checkbox"/> Other _____ | | <input type="checkbox"/> Backyard America | <input type="checkbox"/> The New Yankee Workshop | <input type="checkbox"/> Home Time | <input type="checkbox"/> This Old House | <input type="checkbox"/> The American Woodworker | <input type="checkbox"/> Woodwright's Shop | <input type="checkbox"/> Other _____ | | <input type="checkbox"/> \$20,000-\$29,999 | <input type="checkbox"/> \$60,000-\$69,999 | <input type="checkbox"/> \$30,000-\$39,999 | <input type="checkbox"/> \$70,000-\$79,999 | <input type="checkbox"/> \$40,000-\$49,999 | <input type="checkbox"/> \$80,000-\$89,999 | <input type="checkbox"/> \$50,000-\$59,999 | <input type="checkbox"/> \$90,000 & over | <input type="checkbox"/> 20-29 | <input type="checkbox"/> 50-59 | <input type="checkbox"/> 30-39 | <input type="checkbox"/> 60-69 | <input type="checkbox"/> 40-49 | <input type="checkbox"/> 70 & over | <input type="checkbox"/> 0 - 2 Years | <input type="checkbox"/> 8 - 20 Years | <input type="checkbox"/> 2 - 8 Years | <input type="checkbox"/> 20+ Years | <input type="checkbox"/> Simple | <input type="checkbox"/> Advanced | <input type="checkbox"/> Intermediate | <input type="checkbox"/> Master Craftsman | <input type="checkbox"/> Air Compressor | <input type="checkbox"/> Panel Saw | <input type="checkbox"/> Sander | <input type="checkbox"/> Planer | <input type="checkbox"/> Drill Press | <input type="checkbox"/> Power Feeder | <input type="checkbox"/> Drum Sander | <input type="checkbox"/> Radial Arm Saw | <input type="checkbox"/> Dust Collector | <input type="checkbox"/> Shaper | <input type="checkbox"/> Horizontal Boring Machine | <input type="checkbox"/> Spindle Sander | <input type="checkbox"/> Jointer | <input type="checkbox"/> Table Saw | <input type="checkbox"/> Lathe | <input type="checkbox"/> Vacuum Veneer Press | <input type="checkbox"/> Mortiser | <input type="checkbox"/> Wide Belt Sander | <input type="checkbox"/> Other _____ | | <p>9. How many of your woodworking machines are Grizzly? _____</p> <p>10. Which benchtop tools do you own? Check all that apply.</p> <table border="0" style="width: 100%;"> <tr> <td><input type="checkbox"/> 1" x 42" Belt Sander</td> <td><input type="checkbox"/> 6" - 8" Grinder</td> </tr> <tr> <td><input type="checkbox"/> 5" - 8" Drill Press</td> <td><input type="checkbox"/> Mini Lathe</td> </tr> <tr> <td><input type="checkbox"/> 8" Table Saw</td> <td><input type="checkbox"/> 10" - 12" Thickness Planer</td> </tr> <tr> <td><input type="checkbox"/> 8" - 10" Sander</td> <td><input type="checkbox"/> Scroll Saw</td> </tr> <tr> <td><input type="checkbox"/> Disc/Belt Sander</td> <td><input type="checkbox"/> Spindle/Belt Sander</td> </tr> <tr> <td><input type="checkbox"/> Mini Jointer</td> <td></td> </tr> <tr> <td><input type="checkbox"/> Other _____</td> <td></td> </tr> </table> <p>11. How many of the machines checked above are Grizzly? _____</p> <p>12. Which portable/hand held power tools do you own? Check all that apply.</p> <table border="0" style="width: 100%;"> <tr> <td><input type="checkbox"/> Belt Sander</td> <td><input type="checkbox"/> Orbital Sander</td> </tr> <tr> <td><input type="checkbox"/> Biscuit Joiner</td> <td><input type="checkbox"/> Palm Sander</td> </tr> <tr> <td><input type="checkbox"/> Circular Saw</td> <td><input type="checkbox"/> Portable Planer</td> </tr> <tr> <td><input type="checkbox"/> Detail Sander</td> <td><input type="checkbox"/> Saber Saw</td> </tr> <tr> <td><input type="checkbox"/> Drill/Driver</td> <td><input type="checkbox"/> Reciprocating Saw</td> </tr> <tr> <td><input type="checkbox"/> Miter Saw</td> <td><input type="checkbox"/> Router</td> </tr> <tr> <td><input type="checkbox"/> Other _____</td> <td></td> </tr> </table> <p>13. What machines/supplies would you like Grizzly Industrial to carry?

 _____</p> <p>14. What new accessories would you like Grizzly Industrial to carry?

 _____</p> <p>15. What other companies do you purchase your tools and supplies from?

 _____</p> <p>16. Do you think your purchase represents good value?
 <input type="checkbox"/> Yes <input type="checkbox"/> No</p> <p>17. Would you recommend Grizzly Industrial to a friend?
 <input type="checkbox"/> Yes <input type="checkbox"/> No</p> <p>18. Would you allow us to use your name as a reference for Grizzly customers in your area? Note: We never use names more than three times.
 <input type="checkbox"/> Yes <input type="checkbox"/> No</p> <p>19. Comments: _____

 _____</p> | <input type="checkbox"/> 1" x 42" Belt Sander | <input type="checkbox"/> 6" - 8" Grinder | <input type="checkbox"/> 5" - 8" Drill Press | <input type="checkbox"/> Mini Lathe | <input type="checkbox"/> 8" Table Saw | <input type="checkbox"/> 10" - 12" Thickness Planer | <input type="checkbox"/> 8" - 10" Sander | <input type="checkbox"/> Scroll Saw | <input type="checkbox"/> Disc/Belt Sander | <input type="checkbox"/> Spindle/Belt Sander | <input type="checkbox"/> Mini Jointer | | <input type="checkbox"/> Other _____ | | <input type="checkbox"/> Belt Sander | <input type="checkbox"/> Orbital Sander | <input type="checkbox"/> Biscuit Joiner | <input type="checkbox"/> Palm Sander | <input type="checkbox"/> Circular Saw | <input type="checkbox"/> Portable Planer | <input type="checkbox"/> Detail Sander | <input type="checkbox"/> Saber Saw | <input type="checkbox"/> Drill/Driver | <input type="checkbox"/> Reciprocating Saw | <input type="checkbox"/> Miter Saw | <input type="checkbox"/> Router | <input type="checkbox"/> Other _____ | |
| <input type="checkbox"/> American How-To | <input type="checkbox"/> Today's Homeowner | | | | | | | | | | | | | | | | | | | | | | | | | | | | | | | | | | | | | | | | | | | | | | | | | | | | | | | | | | | | | | | | | | | | | | | | | | | | | | | | | | | | | | | | | | | | | | | | | | | | |
| <input type="checkbox"/> Cabinetmaker | <input type="checkbox"/> WOOD | | | | | | | | | | | | | | | | | | | | | | | | | | | | | | | | | | | | | | | | | | | | | | | | | | | | | | | | | | | | | | | | | | | | | | | | | | | | | | | | | | | | | | | | | | | | | | | | | | | | |
| <input type="checkbox"/> Family Handyman | <input type="checkbox"/> Wooden Boat | | | | | | | | | | | | | | | | | | | | | | | | | | | | | | | | | | | | | | | | | | | | | | | | | | | | | | | | | | | | | | | | | | | | | | | | | | | | | | | | | | | | | | | | | | | | | | | | | | | | |
| <input type="checkbox"/> Fine Homebuilding | <input type="checkbox"/> Woodshop News | | | | | | | | | | | | | | | | | | | | | | | | | | | | | | | | | | | | | | | | | | | | | | | | | | | | | | | | | | | | | | | | | | | | | | | | | | | | | | | | | | | | | | | | | | | | | | | | | | | | |
| <input type="checkbox"/> Home Handyman | <input type="checkbox"/> Woodsmith | | | | | | | | | | | | | | | | | | | | | | | | | | | | | | | | | | | | | | | | | | | | | | | | | | | | | | | | | | | | | | | | | | | | | | | | | | | | | | | | | | | | | | | | | | | | | | | | | | | | |
| <input type="checkbox"/> Journal of Light Construction | <input type="checkbox"/> Woodwork | | | | | | | | | | | | | | | | | | | | | | | | | | | | | | | | | | | | | | | | | | | | | | | | | | | | | | | | | | | | | | | | | | | | | | | | | | | | | | | | | | | | | | | | | | | | | | | | | | | | |
| <input type="checkbox"/> Old House Journal | <input type="checkbox"/> Woodworker | | | | | | | | | | | | | | | | | | | | | | | | | | | | | | | | | | | | | | | | | | | | | | | | | | | | | | | | | | | | | | | | | | | | | | | | | | | | | | | | | | | | | | | | | | | | | | | | | | | | |
| <input type="checkbox"/> Popular Mechanics | <input type="checkbox"/> Woodworker's Journal | | | | | | | | | | | | | | | | | | | | | | | | | | | | | | | | | | | | | | | | | | | | | | | | | | | | | | | | | | | | | | | | | | | | | | | | | | | | | | | | | | | | | | | | | | | | | | | | | | | | |
| <input type="checkbox"/> Popular Science | <input type="checkbox"/> Workbench | | | | | | | | | | | | | | | | | | | | | | | | | | | | | | | | | | | | | | | | | | | | | | | | | | | | | | | | | | | | | | | | | | | | | | | | | | | | | | | | | | | | | | | | | | | | | | | | | | | | |
| <input type="checkbox"/> Popular Woodworking | | | | | | | | | | | | | | | | | | | | | | | | | | | | | | | | | | | | | | | | | | | | | | | | | | | | | | | | | | | | | | | | | | | | | | | | | | | | | | | | | | | | | | | | | | | | | | | | | | | | | |
| <input type="checkbox"/> Other _____ | | | | | | | | | | | | | | | | | | | | | | | | | | | | | | | | | | | | | | | | | | | | | | | | | | | | | | | | | | | | | | | | | | | | | | | | | | | | | | | | | | | | | | | | | | | | | | | | | | | | | |
| <input type="checkbox"/> Backyard America | <input type="checkbox"/> The New Yankee Workshop | | | | | | | | | | | | | | | | | | | | | | | | | | | | | | | | | | | | | | | | | | | | | | | | | | | | | | | | | | | | | | | | | | | | | | | | | | | | | | | | | | | | | | | | | | | | | | | | | | | | |
| <input type="checkbox"/> Home Time | <input type="checkbox"/> This Old House | | | | | | | | | | | | | | | | | | | | | | | | | | | | | | | | | | | | | | | | | | | | | | | | | | | | | | | | | | | | | | | | | | | | | | | | | | | | | | | | | | | | | | | | | | | | | | | | | | | | |
| <input type="checkbox"/> The American Woodworker | <input type="checkbox"/> Woodwright's Shop | | | | | | | | | | | | | | | | | | | | | | | | | | | | | | | | | | | | | | | | | | | | | | | | | | | | | | | | | | | | | | | | | | | | | | | | | | | | | | | | | | | | | | | | | | | | | | | | | | | | |
| <input type="checkbox"/> Other _____ | | | | | | | | | | | | | | | | | | | | | | | | | | | | | | | | | | | | | | | | | | | | | | | | | | | | | | | | | | | | | | | | | | | | | | | | | | | | | | | | | | | | | | | | | | | | | | | | | | | | | |
| <input type="checkbox"/> \$20,000-\$29,999 | <input type="checkbox"/> \$60,000-\$69,999 | | | | | | | | | | | | | | | | | | | | | | | | | | | | | | | | | | | | | | | | | | | | | | | | | | | | | | | | | | | | | | | | | | | | | | | | | | | | | | | | | | | | | | | | | | | | | | | | | | | | |
| <input type="checkbox"/> \$30,000-\$39,999 | <input type="checkbox"/> \$70,000-\$79,999 | | | | | | | | | | | | | | | | | | | | | | | | | | | | | | | | | | | | | | | | | | | | | | | | | | | | | | | | | | | | | | | | | | | | | | | | | | | | | | | | | | | | | | | | | | | | | | | | | | | | |
| <input type="checkbox"/> \$40,000-\$49,999 | <input type="checkbox"/> \$80,000-\$89,999 | | | | | | | | | | | | | | | | | | | | | | | | | | | | | | | | | | | | | | | | | | | | | | | | | | | | | | | | | | | | | | | | | | | | | | | | | | | | | | | | | | | | | | | | | | | | | | | | | | | | |
| <input type="checkbox"/> \$50,000-\$59,999 | <input type="checkbox"/> \$90,000 & over | | | | | | | | | | | | | | | | | | | | | | | | | | | | | | | | | | | | | | | | | | | | | | | | | | | | | | | | | | | | | | | | | | | | | | | | | | | | | | | | | | | | | | | | | | | | | | | | | | | | |
| <input type="checkbox"/> 20-29 | <input type="checkbox"/> 50-59 | | | | | | | | | | | | | | | | | | | | | | | | | | | | | | | | | | | | | | | | | | | | | | | | | | | | | | | | | | | | | | | | | | | | | | | | | | | | | | | | | | | | | | | | | | | | | | | | | | | | |
| <input type="checkbox"/> 30-39 | <input type="checkbox"/> 60-69 | | | | | | | | | | | | | | | | | | | | | | | | | | | | | | | | | | | | | | | | | | | | | | | | | | | | | | | | | | | | | | | | | | | | | | | | | | | | | | | | | | | | | | | | | | | | | | | | | | | | |
| <input type="checkbox"/> 40-49 | <input type="checkbox"/> 70 & over | | | | | | | | | | | | | | | | | | | | | | | | | | | | | | | | | | | | | | | | | | | | | | | | | | | | | | | | | | | | | | | | | | | | | | | | | | | | | | | | | | | | | | | | | | | | | | | | | | | | |
| <input type="checkbox"/> 0 - 2 Years | <input type="checkbox"/> 8 - 20 Years | | | | | | | | | | | | | | | | | | | | | | | | | | | | | | | | | | | | | | | | | | | | | | | | | | | | | | | | | | | | | | | | | | | | | | | | | | | | | | | | | | | | | | | | | | | | | | | | | | | | |
| <input type="checkbox"/> 2 - 8 Years | <input type="checkbox"/> 20+ Years | | | | | | | | | | | | | | | | | | | | | | | | | | | | | | | | | | | | | | | | | | | | | | | | | | | | | | | | | | | | | | | | | | | | | | | | | | | | | | | | | | | | | | | | | | | | | | | | | | | | |
| <input type="checkbox"/> Simple | <input type="checkbox"/> Advanced | | | | | | | | | | | | | | | | | | | | | | | | | | | | | | | | | | | | | | | | | | | | | | | | | | | | | | | | | | | | | | | | | | | | | | | | | | | | | | | | | | | | | | | | | | | | | | | | | | | | |
| <input type="checkbox"/> Intermediate | <input type="checkbox"/> Master Craftsman | | | | | | | | | | | | | | | | | | | | | | | | | | | | | | | | | | | | | | | | | | | | | | | | | | | | | | | | | | | | | | | | | | | | | | | | | | | | | | | | | | | | | | | | | | | | | | | | | | | | |
| <input type="checkbox"/> Air Compressor | <input type="checkbox"/> Panel Saw | | | | | | | | | | | | | | | | | | | | | | | | | | | | | | | | | | | | | | | | | | | | | | | | | | | | | | | | | | | | | | | | | | | | | | | | | | | | | | | | | | | | | | | | | | | | | | | | | | | | |
| <input type="checkbox"/> Sander | <input type="checkbox"/> Planer | | | | | | | | | | | | | | | | | | | | | | | | | | | | | | | | | | | | | | | | | | | | | | | | | | | | | | | | | | | | | | | | | | | | | | | | | | | | | | | | | | | | | | | | | | | | | | | | | | | | |
| <input type="checkbox"/> Drill Press | <input type="checkbox"/> Power Feeder | | | | | | | | | | | | | | | | | | | | | | | | | | | | | | | | | | | | | | | | | | | | | | | | | | | | | | | | | | | | | | | | | | | | | | | | | | | | | | | | | | | | | | | | | | | | | | | | | | | | |
| <input type="checkbox"/> Drum Sander | <input type="checkbox"/> Radial Arm Saw | | | | | | | | | | | | | | | | | | | | | | | | | | | | | | | | | | | | | | | | | | | | | | | | | | | | | | | | | | | | | | | | | | | | | | | | | | | | | | | | | | | | | | | | | | | | | | | | | | | | |
| <input type="checkbox"/> Dust Collector | <input type="checkbox"/> Shaper | | | | | | | | | | | | | | | | | | | | | | | | | | | | | | | | | | | | | | | | | | | | | | | | | | | | | | | | | | | | | | | | | | | | | | | | | | | | | | | | | | | | | | | | | | | | | | | | | | | | |
| <input type="checkbox"/> Horizontal Boring Machine | <input type="checkbox"/> Spindle Sander | | | | | | | | | | | | | | | | | | | | | | | | | | | | | | | | | | | | | | | | | | | | | | | | | | | | | | | | | | | | | | | | | | | | | | | | | | | | | | | | | | | | | | | | | | | | | | | | | | | | |
| <input type="checkbox"/> Jointer | <input type="checkbox"/> Table Saw | | | | | | | | | | | | | | | | | | | | | | | | | | | | | | | | | | | | | | | | | | | | | | | | | | | | | | | | | | | | | | | | | | | | | | | | | | | | | | | | | | | | | | | | | | | | | | | | | | | | |
| <input type="checkbox"/> Lathe | <input type="checkbox"/> Vacuum Veneer Press | | | | | | | | | | | | | | | | | | | | | | | | | | | | | | | | | | | | | | | | | | | | | | | | | | | | | | | | | | | | | | | | | | | | | | | | | | | | | | | | | | | | | | | | | | | | | | | | | | | | |
| <input type="checkbox"/> Mortiser | <input type="checkbox"/> Wide Belt Sander | | | | | | | | | | | | | | | | | | | | | | | | | | | | | | | | | | | | | | | | | | | | | | | | | | | | | | | | | | | | | | | | | | | | | | | | | | | | | | | | | | | | | | | | | | | | | | | | | | | | |
| <input type="checkbox"/> Other _____ | | | | | | | | | | | | | | | | | | | | | | | | | | | | | | | | | | | | | | | | | | | | | | | | | | | | | | | | | | | | | | | | | | | | | | | | | | | | | | | | | | | | | | | | | | | | | | | | | | | | | |
| <input type="checkbox"/> 1" x 42" Belt Sander | <input type="checkbox"/> 6" - 8" Grinder | | | | | | | | | | | | | | | | | | | | | | | | | | | | | | | | | | | | | | | | | | | | | | | | | | | | | | | | | | | | | | | | | | | | | | | | | | | | | | | | | | | | | | | | | | | | | | | | | | | | |
| <input type="checkbox"/> 5" - 8" Drill Press | <input type="checkbox"/> Mini Lathe | | | | | | | | | | | | | | | | | | | | | | | | | | | | | | | | | | | | | | | | | | | | | | | | | | | | | | | | | | | | | | | | | | | | | | | | | | | | | | | | | | | | | | | | | | | | | | | | | | | | |
| <input type="checkbox"/> 8" Table Saw | <input type="checkbox"/> 10" - 12" Thickness Planer | | | | | | | | | | | | | | | | | | | | | | | | | | | | | | | | | | | | | | | | | | | | | | | | | | | | | | | | | | | | | | | | | | | | | | | | | | | | | | | | | | | | | | | | | | | | | | | | | | | | |
| <input type="checkbox"/> 8" - 10" Sander | <input type="checkbox"/> Scroll Saw | | | | | | | | | | | | | | | | | | | | | | | | | | | | | | | | | | | | | | | | | | | | | | | | | | | | | | | | | | | | | | | | | | | | | | | | | | | | | | | | | | | | | | | | | | | | | | | | | | | | |
| <input type="checkbox"/> Disc/Belt Sander | <input type="checkbox"/> Spindle/Belt Sander | | | | | | | | | | | | | | | | | | | | | | | | | | | | | | | | | | | | | | | | | | | | | | | | | | | | | | | | | | | | | | | | | | | | | | | | | | | | | | | | | | | | | | | | | | | | | | | | | | | | |
| <input type="checkbox"/> Mini Jointer | | | | | | | | | | | | | | | | | | | | | | | | | | | | | | | | | | | | | | | | | | | | | | | | | | | | | | | | | | | | | | | | | | | | | | | | | | | | | | | | | | | | | | | | | | | | | | | | | | | | | |
| <input type="checkbox"/> Other _____ | | | | | | | | | | | | | | | | | | | | | | | | | | | | | | | | | | | | | | | | | | | | | | | | | | | | | | | | | | | | | | | | | | | | | | | | | | | | | | | | | | | | | | | | | | | | | | | | | | | | | |
| <input type="checkbox"/> Belt Sander | <input type="checkbox"/> Orbital Sander | | | | | | | | | | | | | | | | | | | | | | | | | | | | | | | | | | | | | | | | | | | | | | | | | | | | | | | | | | | | | | | | | | | | | | | | | | | | | | | | | | | | | | | | | | | | | | | | | | | | |
| <input type="checkbox"/> Biscuit Joiner | <input type="checkbox"/> Palm Sander | | | | | | | | | | | | | | | | | | | | | | | | | | | | | | | | | | | | | | | | | | | | | | | | | | | | | | | | | | | | | | | | | | | | | | | | | | | | | | | | | | | | | | | | | | | | | | | | | | | | |
| <input type="checkbox"/> Circular Saw | <input type="checkbox"/> Portable Planer | | | | | | | | | | | | | | | | | | | | | | | | | | | | | | | | | | | | | | | | | | | | | | | | | | | | | | | | | | | | | | | | | | | | | | | | | | | | | | | | | | | | | | | | | | | | | | | | | | | | |
| <input type="checkbox"/> Detail Sander | <input type="checkbox"/> Saber Saw | | | | | | | | | | | | | | | | | | | | | | | | | | | | | | | | | | | | | | | | | | | | | | | | | | | | | | | | | | | | | | | | | | | | | | | | | | | | | | | | | | | | | | | | | | | | | | | | | | | | |
| <input type="checkbox"/> Drill/Driver | <input type="checkbox"/> Reciprocating Saw | | | | | | | | | | | | | | | | | | | | | | | | | | | | | | | | | | | | | | | | | | | | | | | | | | | | | | | | | | | | | | | | | | | | | | | | | | | | | | | | | | | | | | | | | | | | | | | | | | | | |
| <input type="checkbox"/> Miter Saw | <input type="checkbox"/> Router | | | | | | | | | | | | | | | | | | | | | | | | | | | | | | | | | | | | | | | | | | | | | | | | | | | | | | | | | | | | | | | | | | | | | | | | | | | | | | | | | | | | | | | | | | | | | | | | | | | | |
| <input type="checkbox"/> Other _____ | | | | | | | | | | | | | | | | | | | | | | | | | | | | | | | | | | | | | | | | | | | | | | | | | | | | | | | | | | | | | | | | | | | | | | | | | | | | | | | | | | | | | | | | | | | | | | | | | | | | | |

FOLD ALONG DOTTED LINE



Place
Stamp
Here



GRIZZLY INDUSTRIAL, INC.
P.O. BOX 2069
BELLINGHAM, WA 98227-2069



FOLD ALONG DOTTED LINE

Send a Grizzly Catalog to a friend:

Name _____
Street _____
City _____ State _____ Zip _____

TAPE ALONG EDGES--PLEASE DO NOT STAPLE