

Grizzly **Industrial, Inc.**®

MODEL G9972Z **11" X 26" LIGHT-DUTY** **LATHE w/GEARBOX** **OWNER'S MANUAL** *(For models manufactured since 03/20)*

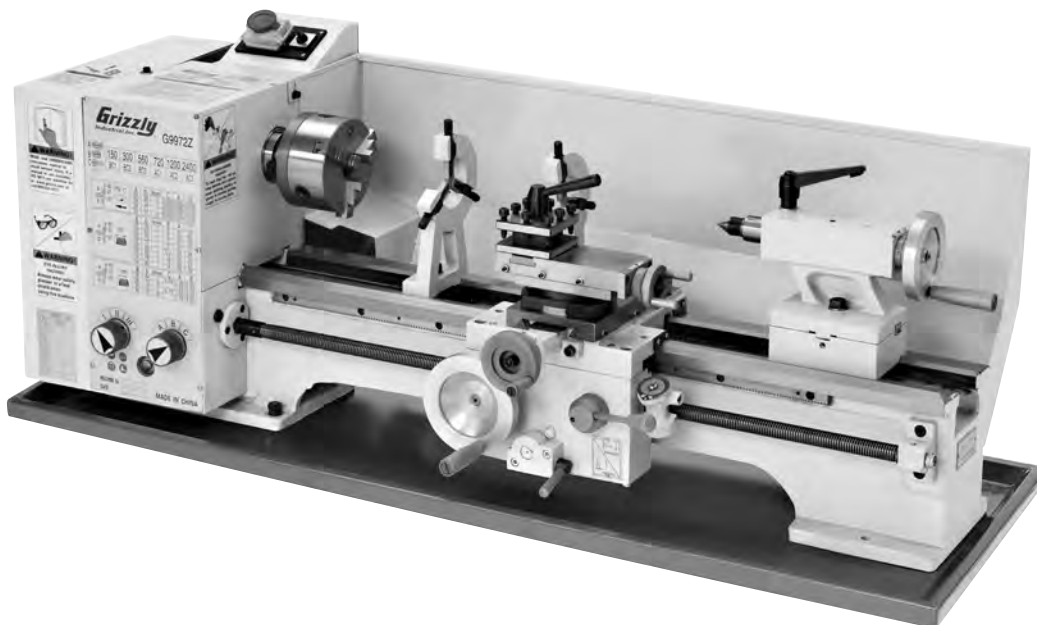

COPYRIGHT © JULY, 2008 BY GRIZZLY INDUSTRIAL, INC., REVISED APRIL, 2020 (CS)
WARNING: NO PORTION OF THIS MANUAL MAY BE REPRODUCED IN ANY SHAPE
OR FORM WITHOUT THE WRITTEN APPROVAL OF GRIZZLY INDUSTRIAL, INC.

#TS10714 PRINTED IN CHINA

V3.04.20



WARNING!

This manual provides critical safety instructions on the proper setup, operation, maintenance, and service of this machine/tool. Save this document, refer to it often, and use it to instruct other operators.

Failure to read, understand and follow the instructions in this manual may result in fire or serious personal injury—including amputation, electrocution, or death.

The owner of this machine/tool is solely responsible for its safe use. This responsibility includes but is not limited to proper installation in a safe environment, personnel training and usage authorization, proper inspection and maintenance, manual availability and comprehension, application of safety devices, cutting/sanding/grinding tool integrity, and the usage of personal protective equipment.

The manufacturer will not be held liable for injury or property damage from negligence, improper training, machine modifications or misuse.



WARNING!

Some dust created by power sanding, sawing, grinding, drilling, and other construction activities contains chemicals known to the State of California to cause cancer, birth defects or other reproductive harm. Some examples of these chemicals are:

- **Lead from lead-based paints.**
- **Crystalline silica from bricks, cement and other masonry products.**
- **Arsenic and chromium from chemically-treated lumber.**

Your risk from these exposures varies, depending on how often you do this type of work. To reduce your exposure to these chemicals: Work in a well ventilated area, and work with approved safety equipment, such as those dust masks that are specially designed to filter out microscopic particles.

Table of Contents

INTRODUCTION	2	SECTION 5: ACCESSORIES	47
Foreword	2	SECTION 6: MAINTENANCE	50
Contact Info	2	Schedule	50
Functional Overview	2	Cleaning & Protecting	50
Identification	3	Lubrication	51
Controls & Components	4	SECTION 7: SERVICE	55
Machine Data Sheet	6	Troubleshooting	55
SECTION 1: SAFETY	8	Cross Slide Backlash Adjustment	58
Safety Instructions for Machinery	8	Gib Adjustments	59
Additional Safety for Metal Lathes	10	Half-Nut Adjustment	60
Additional Safety for Chucks	11	Shear Pin Replacement	60
SECTION 2: POWER SUPPLY	12	Ribbed Belt Replacement	61
SECTION 3: SETUP	14	Bearing Preload	61
Preparation	14	SECTION 8: WIRING	64
Unpacking	14	Wiring Safety Instructions	64
Needed for Setup	14	Wiring Diagram	65
Inventory	15	SECTION 9: PARTS	66
Cleanup	15	Headstock	66
Site Considerations	16	Change Gears	68
Moving & Placement	16	Feed Rate Gearbox	69
Mounting	17	Apron	71
Check Gearbox Oil	18	Saddle & Cross Slide	73
Test Run	18	Compound Slide & Tool Post	74
Spindle Break-In	20	Tailstock	75
Carriage Lock	21	Bed	76
Recommended Adjustments	21	Steady Rest	77
SECTION 4: OPERATIONS	22	Follow Rest	77
Operation Overview	22	Electrical Components	78
Chuck & Faceplate Mounting	23	Accessories	79
Installation & Removal Devices	23	Labels & Cosmetics	80
Chuck Installation	24	WARRANTY & RETURNS	81
Chuck Removal	25		
Changing Jaw Set	26		
Scroll Chuck Clamping	27		
4-Jaw Chuck	27		
Faceplate	28		
Tailstock	29		
Centers	33		
Steady Rest	35		
Follow Rest	36		
Compound Rest	36		
Four-Way Tool Post	37		
Manual Feed	38		
Spindle Speed	39		
Power Feed	41		
Feed Rate	42		
Threading Controls	45		

INTRODUCTION

Machine Description

The primary purpose of Model G9972Z 11" x 26" Light-Duty Lathe w/Gearbox is to make concentric cuts in metal stock. With the lathe, round stock can be made perfectly concentric, threaded, drilled, knurled, bored, tapered, etc. Square stock can be made into precision round shafts used for axles, spindles, leadscrews, punches, etc.

The maximum size of workpiece a lathe can cut is determined by the swing, which is the distance from the center line of the spindle to the bed, and the throw, which is the maximum distance between the tailstock and the spindle. However, this lathe features an open spindle that allows longer workpieces to extend through the headstock. The carriage, which moves left and right, is equipped with a power feed system for automated cutting and threading operations.

Contact Info

We stand behind our machines! If you have questions or need help, contact us with the information below. Before contacting, make sure you get the **serial number** and **manufacture date** from the machine ID label. This will help us help you faster.

Grizzly Technical Support
1815 W. Battlefield
Springfield, MO 65807
Phone: (570) 546-9663
Email: techsupport@grizzly.com

We want your feedback on this manual. What did you like about it? Where could it be improved? Please take a few minutes to give us feedback.

Grizzly Documentation Manager
P.O. Box 2069
Bellingham, WA 98227-2069
Email: manuals@grizzly.com

Manual Accuracy

We are proud to provide a high-quality owner's manual with your new machine!

We made every effort to be exact with the instructions, specifications, drawings, and photographs in this manual. Sometimes we make mistakes, but our policy of continuous improvement also means that **sometimes the machine you receive is slightly different than shown in the manual.**

If you find this to be the case, and the difference between the manual and machine leaves you confused or unsure about something, check our website for an updated version. We post current manuals and manual updates for free on our website at www.grizzly.com.

Alternatively, you can call our Technical Support for help. Before calling, make sure you write down the **Manufacture Date** and **Serial Number** from the machine ID label (see below). This information is required for us to provide proper tech support, and it helps us determine if updated documentation is available for your machine.

Grizzly Industrial		MODEL GXXXX	
		MACHINE NAME	
SPECIFICATIONS		▲ WARNING!	
Motor:		To reduce risk of serious injury when using this machine:	
Specification:		Read manual before operation.	
Specification:		Wear safety glasses and respirator.	
Specification:		Ensure safety devices are correctly adjusted/setup and	
Weight:		power is connected to grounded circuit before starting.	
		4. Make sure the motor has stopped and disconnect	
		power before adjustments, maintenance, or service.	
		5. DO NOT expose to rain or dampness.	
		6. DO NOT modify this machine in any way.	
		7.	
		8.	
		9. Do not use while under the influence of drugs or alcohol.	
		10. Maintain machine carefully to prevent accidents.	
		Manufactured for Grizzly in Taiwan	



Identification

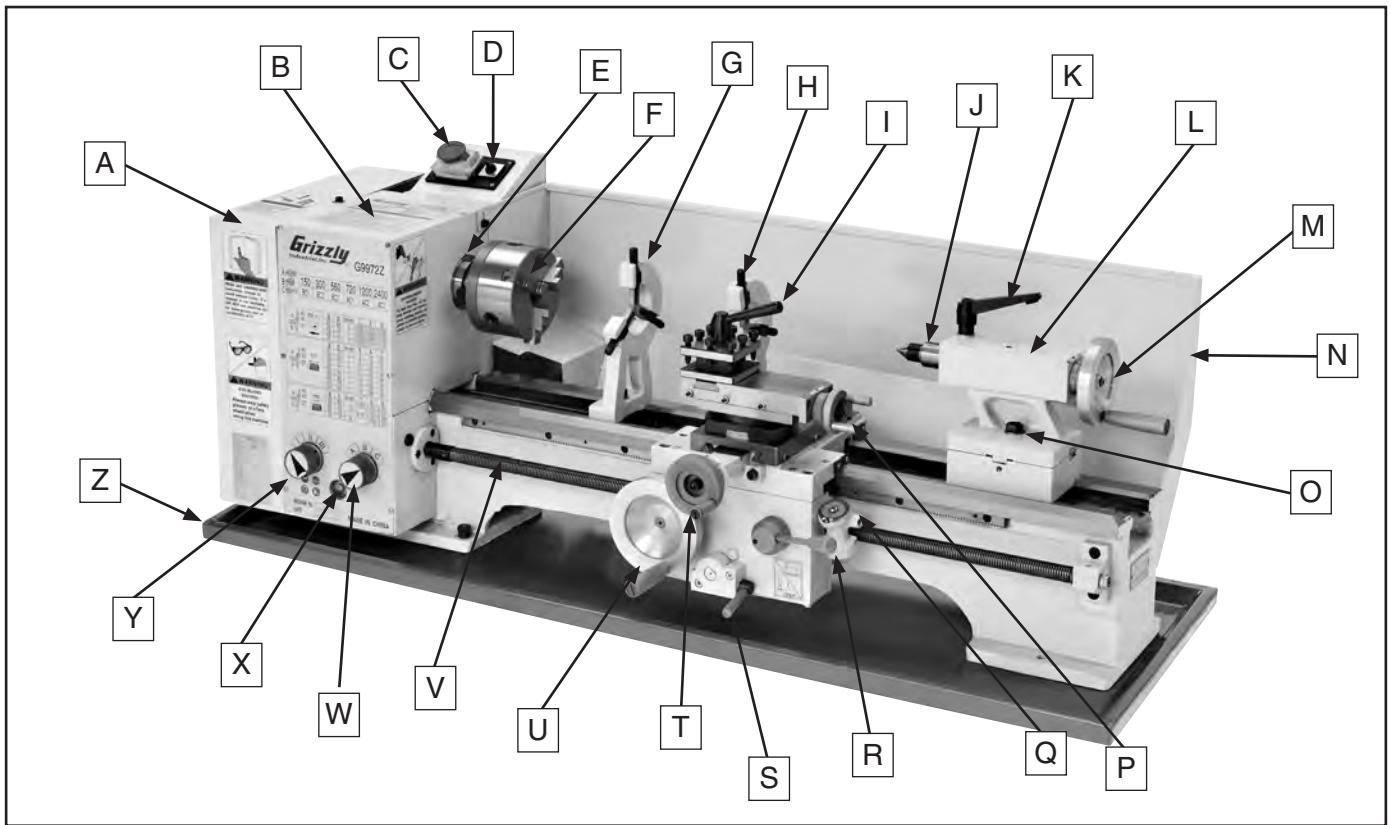

Figure 1. Model G9972Z identification.

- | | |
|--|---|
| A. Change Gear Cover | N. Splash Guard |
| B. Headstock | O. Tailstock Lock Bolt |
| C. Motor ON/OFF Switch | P. Compound Slide & Handwheel |
| D. Spindle Switch | Q. Thread Dial |
| E. Threaded Spindle 1 $\frac{3}{4}$ "-8 MT#4 | R. Half-Nut Lever |
| F. 3-Jaw Chuck 5" | S. Power Feed Lever |
| G. Steady Rest | T. Cross Slide Handwheel |
| H. Follow Rest | U. Carriage Handwheel |
| I. 4-Way Tool Post | V. Leadscrew $\frac{3}{4}$ "-8 x 34 $\frac{1}{2}$ " |
| J. Tailstock Quill | W. Right Feed Rate Dial |
| K. Quill Lock | X. Feed Rate Gearbox Oil Sight Glass |
| L. Tailstock | Y. Left Feed Rate Dial |
| M. Quill Handwheel | Z. Chip Pan |



Controls & Components



Refer to the following figures and descriptions to become familiar with the basic controls and components of this machine. Understanding these items and how they work will help you understand the rest of the manual and minimize your risk of injury when operating this machine.

Headstock

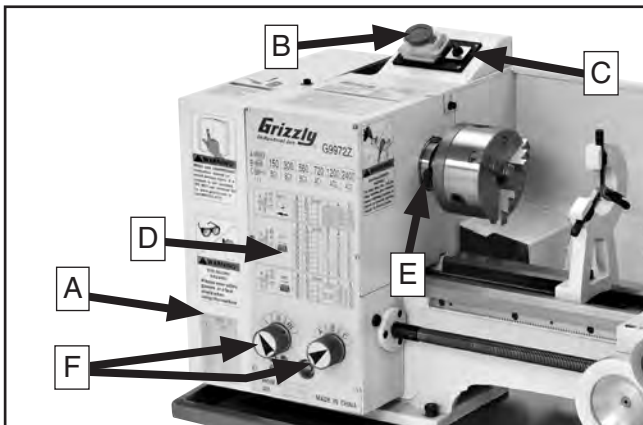

Figure 2. Headstock controls and charts.

- A. **Thread Dial Chart:** Shows the numbers on the thread dial to engage the half-nut for threading operations.
- B. **Power Switch:** Allows power to flow to the motor—lift the switch for the ON button, and press the top red button to cut power to the motor.
- C. **Spindle Switch:** Starts/stops spindle rotation—turn the switch to the left for clockwise rotation, to the right for counterclockwise rotation, and to the center to stop spindle rotation.

- D. **Configuration Chart:** Provides configuration information for spindle speeds, power feed rates, and threading operations.
- E. **Spindle:** Holds a chuck, faceplate, or center for workpiece mounting.
- F. **Feed Rate Dials:** Configure the feed rate gearing for carriage power feed and threading operations.

Tailstock

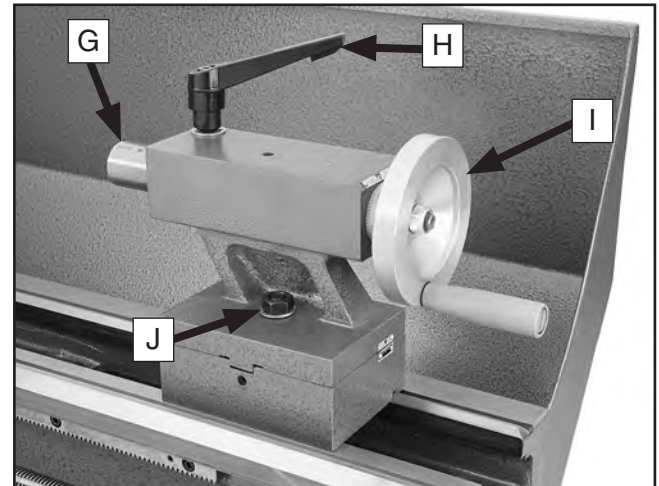

Figure 3. Tailstock controls and components.

- G. **Quill:** Holds a tapered center or tool and moves toward or away from the spindle with the use of the handwheel.
- H. **Quill Lock:** Locks the quill and the installed tool in place.
- I. **Quill Handwheel:** Moves the quill in and out of the tailstock casting.
- J. **Tailstock Lock Nut:** Secures the tailstock in place on the bedway.



Carriage

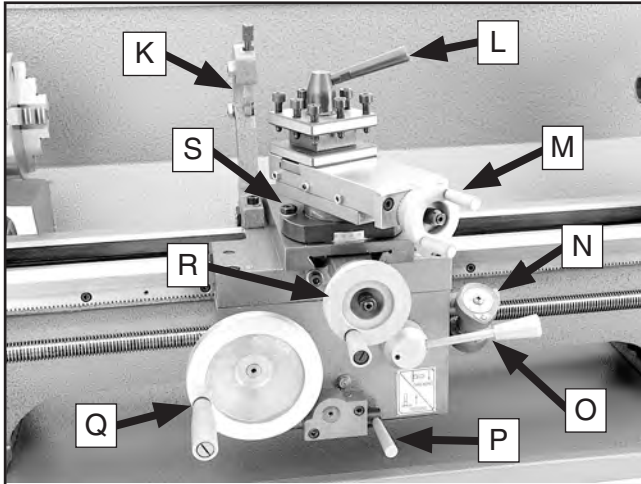

Figure 4. Carriage controls and components.

- K. Follow Rest:** Follows the movement of the carriage and provides support for long, slender stock to prevent workpiece flexing from the pressure of the cutting tool.
- L. 4-Way Tool Post Lock Lever:** Secures the cutting tools in the tool post.
- M. Compound Slide Handwheel:** Moves the compound slide and tooling toward or away from the workpiece.
- N. Thread Dial:** Shows when to engage the half-nut during inch threading operations.
- O. Half-Nut Lever:** Opens and closes the half-nut on the longitudinal leadscrew, which engages the carriage power feed for threading.
- P. Power Feed Lever:** Configures the apron gears for powered carriage movement. Move the lever up to engage the power feed and down to disengage.

NOTICE

NEVER attempt to engage the carriage power feed (lever up) and the half-nut (lever down) at the same time, and **NEVER** force these levers. Always disengage the half-nut (lever up) before moving the power feed lever up. Otherwise, severe damage to the lathe could occur.

- Q. Carriage Handwheel:** Moves the carriage along the bedway.
- R. Cross Slide Handwheel:** Move the cross slide and tooling in a path perpendicular to the workpiece.
- S. Compound Slide Lock Nuts:** Secures the rotational position of the compound slide





MACHINE DATA SHEET

Customer Service #: (570) 546-9663 · To Order Call: (800) 523-4777 · Fax #: (800) 438-5901

MODEL G9972Z 11" X 26" BENCH LATHE W/ GEARBOX

Product Dimensions:

Weight..... 490 lbs.
 Width (side-to-side) x Depth (front-to-back) x Height..... 51 x 23 x 19 in.
 Footprint (Length x Width)..... 51 x 18 in.

Shipping Dimensions:

Type..... Wood Crate
 Content..... Machine
 Weight..... 560 lbs.
 Length x Width x Height..... 58 x 30 x 26 in.
 Must Ship Upright..... Yes

Electrical:

Power Requirement..... 110V, Single-Phase, 60 Hz
 Full-Load Current Rating..... 13.6A
 Minimum Circuit Size..... 20A
 Connection Type..... Cord & Plug
 Power Cord Included..... Yes
 Power Cord Length..... 4 ft.
 Power Cord Gauge..... 12 AWG
 Plug Included..... Yes
 Included Plug Type..... 5-15
 Switch Type..... ON/OFF Push Button Switch w/Safety Cover

Motors:

Main

Horsepower..... 1 HP
 Phase..... Single-Phase
 Amps..... 13.6A
 Speed..... 1725 RPM
 Type..... TEFC Capacitor-Start Induction
 Power Transfer Belt Drive
 Bearings..... Shielded & Permanently Lubricated
 Centrifugal Switch/Contacts Type..... Internal

Main Specifications:

Operation Info

Swing Over Bed..... 10-1/2 in.
 Distance Between Centers..... 26 in.
 Swing Over Cross Slide..... 6-3/8 in.
 Swing Over Saddle..... 6-3/8 in.
 Maximum Tool Bit Size..... 1/2 in.
 Compound Travel..... 3-1/2 in.
 Carriage Travel..... 23 in.
 Cross Slide Travel..... 7 in.



Headstock Info

Spindle Bore..... 25 mm
Spindle Size..... 1-3/4 in.
Spindle Taper..... MT#4
Spindle Threads..... 8 TPI
Number of Spindle Speeds..... 6
Spindle Speeds..... 150 – 2400 RPM
Spindle Type..... Threaded
Spindle Bearings..... Tapered Roller

Tailstock Info

Tailstock Quill Travel..... 2-1/2 in.
Tailstock Taper..... MT#3
Tailstock Barrel Diameter..... 1.125 in.

Threading Info

Number of Longitudinal Feeds..... 12
Range of Longitudinal Feeds..... 0.0022 – 0.0150 in./rev.
Number of Inch Threads..... 24
Range of Inch Threads..... 8 – 56 TPI
Number of Metric Threads..... 10
Range of Metric Threads..... 0.5 – 3.0 mm

Dimensions

Bed Width..... 6 in.
Carriage Leadscrew Diameter..... 3/4 in.
Leadscrew TPI..... 8 TPI
Carriage Leadscrew Length..... 34-1/2 in.
Steady Rest Capacity..... 1/4 – 2 in.
Follow Rest Capacity..... 1/4 – 2 in.
Faceplate Size..... 8 in.

Other

Optional Stand..... G9973

Construction

Base..... Formed Steel
Headstock..... Cast Iron
End Gears..... Steel
Bed..... Hardened and Precision-Ground Cast Iron
Body..... Cast Iron
Paint Type/Finish..... Epoxy

Other Specifications:

Country of Origin China
Warranty 1 Year
Approximate Assembly & Setup Time 1 Hour
Serial Number Location ID Label

Features:

- Easy to Read Control Panel
- Emergency Stop
- Long Bed Accommodates 26" Between Centers
- Threading Dial



SECTION 1: SAFETY

For Your Own Safety, Read Instruction Manual Before Operating This Machine

The purpose of safety symbols is to attract your attention to possible hazardous conditions. This manual uses a series of symbols and signal words intended to convey the level of importance of the safety messages. The progression of symbols is described below. Remember that safety messages by themselves do not eliminate danger and are not a substitute for proper accident prevention measures. Always use common sense and good judgment.



Indicates an imminently hazardous situation which, if not avoided, **WILL** result in death or serious injury.



Indicates a potentially hazardous situation which, if not avoided, **COULD** result in death or serious injury.



Indicates a potentially hazardous situation which, if not avoided, **MAY** result in minor or moderate injury. It may also be used to alert against unsafe practices.

NOTICE

Alerts the user to useful information about proper operation of the machine to avoid machine damage.

Safety Instructions for Machinery

WARNING

OWNER'S MANUAL. Read and understand this owner's manual **BEFORE** using machine.

TRAINED OPERATORS ONLY. Untrained operators have a higher risk of being hurt or killed. Only allow trained/supervised people to use this machine. When machine is not being used, disconnect power, remove switch keys, or lock-out machine to prevent unauthorized use—especially around children. Make your workshop kid proof!

DANGEROUS ENVIRONMENTS. Do not use machinery in areas that are wet, cluttered, or have poor lighting. Operating machinery in these areas greatly increases the risk of accidents and injury.

MENTAL ALERTNESS REQUIRED. Full mental alertness is required for safe operation of machinery. Never operate under the influence of drugs or alcohol, when tired, or when distracted.

ELECTRICAL EQUIPMENT INJURY RISKS. You can be shocked, burned, or killed by touching live electrical components or improperly grounded machinery. To reduce this risk, only allow qualified service personnel to do electrical installation or repair work, and always disconnect power before accessing or exposing electrical equipment.

DISCONNECT POWER FIRST. Always disconnect machine from power supply **BEFORE** making adjustments, changing tooling, or servicing machine. This prevents an injury risk from unintended startup or contact with live electrical components.

EYE PROTECTION. Always wear ANSI-approved safety glasses or a face shield when operating or observing machinery to reduce the risk of eye injury or blindness from flying particles. Everyday eyeglasses are **NOT** approved safety glasses.



WARNING

WEARING PROPER APPAREL. Do not wear clothing, apparel or jewelry that can become entangled in moving parts. Always tie back or cover long hair. Wear non-slip footwear to reduce risk of slipping and losing control or accidentally contacting cutting tool or moving parts.

HAZARDOUS DUST. Dust created by machinery operations may cause cancer, birth defects, or long-term respiratory damage. Be aware of dust hazards associated with each workpiece material. Always wear a NIOSH-approved respirator to reduce your risk.

HEARING PROTECTION. Always wear hearing protection when operating or observing loud machinery. Extended exposure to this noise without hearing protection can cause permanent hearing loss.

REMOVE ADJUSTING TOOLS. Tools left on machinery can become dangerous projectiles upon startup. Never leave chuck keys, wrenches, or any other tools on machine. Always verify removal before starting!

USE CORRECT TOOL FOR THE JOB. Only use this tool for its intended purpose—do not force it or an attachment to do a job for which it was not designed. Never make unapproved modifications—modifying tool or using it differently than intended may result in malfunction or mechanical failure that can lead to personal injury or death!

AWKWARD POSITIONS. Keep proper footing and balance at all times when operating machine. Do not overreach! Avoid awkward hand positions that make workpiece control difficult or increase the risk of accidental injury.

CHILDREN & BYSTANDERS. Keep children and bystanders at a safe distance from the work area. Stop using machine if they become a distraction.

GUARDS & COVERS. Guards and covers reduce accidental contact with moving parts or flying debris. Make sure they are properly installed, undamaged, and working correctly BEFORE operating machine.

FORCING MACHINERY. Do not force machine. It will do the job safer and better at the rate for which it was designed.

NEVER STAND ON MACHINE. Serious injury may occur if machine is tipped or if the cutting tool is unintentionally contacted.

STABLE MACHINE. Unexpected movement during operation greatly increases risk of injury or loss of control. Before starting, verify machine is stable and mobile base (if used) is locked.

USE RECOMMENDED ACCESSORIES. Consult this owner's manual or the manufacturer for recommended accessories. Using improper accessories will increase the risk of serious injury.

UNATTENDED OPERATION. To reduce the risk of accidental injury, turn machine **OFF** and ensure all moving parts completely stop before walking away. Never leave machine running while unattended.

MAINTAIN WITH CARE. Follow all maintenance instructions and lubrication schedules to keep machine in good working condition. A machine that is improperly maintained could malfunction, leading to serious personal injury or death.

DAMAGED PARTS. Regularly inspect machine for damaged, loose, or mis-adjusted parts—or any condition that could affect safe operation. Immediately repair/replace BEFORE operating machine. For your own safety, DO NOT operate machine with damaged parts!

MAINTAIN POWER CORDS. When disconnecting cord-connected machines from power, grab and pull the plug—NOT the cord. Pulling the cord may damage the wires inside. Do not handle cord/plug with wet hands. Avoid cord damage by keeping it away from heated surfaces, high traffic areas, harsh chemicals, and wet/damp locations.

EXPERIENCING DIFFICULTIES. If at any time you experience difficulties performing the intended operation, stop using the machine! Contact our Technical Support at (570) 546-9663.



Additional Safety for Metal Lathes

WARNING

Serious injury or death can occur from getting entangled in, crushed between, or struck by rotating parts on a lathe! Unsecured tools or workpieces that fly loose from rotating objects can also strike nearby operators with deadly force. To minimize the risk of getting hurt or killed, anyone operating this machine **MUST** completely heed the hazards and warnings below.

CLOTHING, JEWELRY & LONG HAIR. Tie back long hair, remove jewelry, and do not wear loose clothing or gloves. These can easily get caught on rotating parts and pull you into lathe.

ROTATING PARTS. Always keep hands and body at a safe distance from rotating parts—especially those with projecting surfaces. Never hold anything against rotating workpiece, such as emery cloth, that can pull you into lathe.

GUARDING. Guards and covers protect against entanglement or flying objects. Always ensure they are properly installed while machine is running.

ADJUSTMENT TOOLS. Remove all chuck keys, wrenches, and adjustment tools before turning lathe **ON**. A tool left on the lathe can become a deadly projectile when spindle is started.

SAFE CLEARANCES. Before starting spindle, verify workpiece has adequate clearance by hand-rotating it through its entire range of motion.

NEW SETUPS. Test each new setup by starting spindle rotation at the lowest speed and standing to the side of the lathe until workpiece reaches full speed and you can verify safe rotation.

SPINDLE SPEEDS. Using spindle speeds that are too fast for the workpiece or clamping equipment can cause rotating parts to come loose and strike nearby people with deadly force. Always use slow spindle speeds with large or non-concentric workpieces. Never exceed rated RPM of the chuck.

LONG STOCK SAFETY. Long stock can whip violently if not properly supported. Always support any stock that extends from the chuck/headstock more than three times its own diameter.

CLEARING CHIPS. Metal chips can be razor sharp. Avoid clearing them by hand or with a rag. Use a brush or vacuum instead.

SECURE WORKPIECE. An improperly secured workpiece can fly off spindle with deadly force. Make sure workpiece is properly secured before starting the lathe.

CHUCKS. Chucks can be heavy and difficult to hold. During installation and removal, protect your hands and precision bed ways by using a chuck cradle or piece of plywood over the bed ways. Use lifting equipment, as necessary, for large chucks.

STOPPING SPINDLE. Always allow spindle to completely stop on its own, or use a brake, if provided. Never put hands or another object on a spinning workpiece to make it stop faster.

CRASHING. A serious explosion of metal parts can occur if cutting tool or other lathe component hits rotating chuck or a projecting part of workpiece. Resulting metal fragments can strike nearby people and lathe will be seriously damaged. To reduce risk of crashing, **ALWAYS** release automatic feeds after use, **NEVER** leave lathe unattended, and **CHECK** all clearances before starting lathe.

COOLANT SAFETY. Coolant can become very toxic through prolonged use and aging. To minimize toxicity, change coolant regularly. When using, position nozzle properly to avoid splashing operator or causing a slipping hazard on floor.

TOOL SELECTION. Cutting with incorrect or dull tooling increases risk of injury from broken or dislodged components, or as a result of extra force required for operation. Always use sharp tooling that is right for the job.

SANDING/POLISHING. To reduce risk of entanglement, never wrap emery cloth around rotating workpiece. Instead, use emery cloth with the aid of a tool or backing board.

MEASURING WORKPIECE. To reduce risk of entanglement, never measure rotating workpieces.



Additional Safety for Chucks

WARNING

ENTANGLEMENT. Entanglement with a rotating chuck can lead to death, amputation, broken bones, or other serious injury. Never attempt to slow or stop the lathe chuck by hand, and always roll up long sleeves, tie back long hair, and remove any jewelry or loose apparel BEFORE operating.

CHUCK SPEED RATING. Excessive spindle speeds greatly increase the risk of the workpiece or chuck being thrown from the machine with deadly force. Never use spindle speeds faster than the chuck RPM rating or the safe limits of your workpiece.

USING CORRECT EQUIPMENT. Many workpieces can only be safely turned in a lathe if additional support equipment, such as a tailstock or steady/follow rest, is used. If the operation is too hazardous to be completed with the lathe or existing equipment, the operator must have enough experience to know when to use a different machine or find a safer way.

TRAINED OPERATORS ONLY. Using a chuck incorrectly can result in workpieces coming loose at high speeds and striking the operator or bystanders with deadly force. To reduce the risk of this hazard, read and understand this document and seek additional training from an experienced chuck user before using a chuck.

CHUCK CAPACITY. Avoid exceeding the capacity of the chuck by clamping an oversized workpiece. If the workpiece is too large to safely clamp with the chuck, use a faceplate or a larger chuck if possible. Otherwise, the workpiece could be thrown from the lathe during operation, resulting in serious impact injury or death.

CLAMPING FORCE. Inadequate clamping force can lead to the workpiece being thrown from the chuck and striking the operator or bystanders. Maximum clamping force is achieved when the chuck is properly maintained and lubricated, all jaws are fully engaged with the workpiece, and the maximum chuck clamping diameter is not exceeded.

PROPER MAINTENANCE. All chucks must be properly maintained and lubricated to achieve maximum clamping force and withstand the rigors of centrifugal force. To reduce the risk of a thrown workpiece, follow all maintenance intervals and instructions in this document.

DISCONNECT POWER. Serious entanglement or impact injuries could occur if the lathe is started while you are adjusting, servicing, or installing the chuck. Always disconnect the lathe from power before performing these procedures.

WARNING

Like all machinery there is potential danger when operating this machine. Accidents are frequently caused by lack of familiarity or failure to pay attention. Use this machine with respect and caution to decrease the risk of operator injury. If normal safety precautions are overlooked or ignored, serious personal injury may occur.

CAUTION

No list of safety guidelines can be complete. Every shop environment is different. Always consider safety first, as it applies to your individual working conditions. Use this and other machinery with caution and respect. Failure to do so could result in serious personal injury, damage to equipment, or poor work results.



SECTION 2: POWER SUPPLY

Availability

Before installing the machine, consider the availability and proximity of the required power supply circuit. If an existing circuit does not meet the requirements for this machine, a new circuit must be installed. To minimize the risk of electrocution, fire, or equipment damage, installation work and electrical wiring must be done by an electrician or qualified service personnel in accordance with all applicable codes and standards.

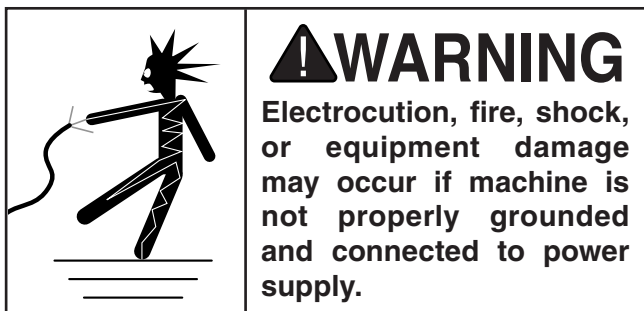

Full-Load Current Rating

The full-load current rating is the amperage a machine draws at 100% of the rated output power. On machines with multiple motors, this is the amperage drawn by the largest motor or sum of all motors and electrical devices that might operate at one time during normal operations.

Full-Load Current Rating at 110V... 13.6 Amps

The full-load current is not the maximum amount of amps that the machine will draw. If the machine is overloaded, it will draw additional amps beyond the full-load rating.

If the machine is overloaded for a sufficient length of time, damage, overheating, or fire may result—especially if connected to an undersized circuit. To reduce the risk of these hazards, avoid overloading the machine during operation and make sure it is connected to a power supply circuit that meets the specified circuit requirements.

! WARNING

Serious injury could occur if you connect machine to power before completing setup process. DO NOT connect to power until instructed later in this manual.

110V Circuit Requirements

This machine is prewired to operate on a power supply circuit that has a verified ground and meets the following requirements:

Nominal Voltage 110V, 115V, 120V
Cycle 60 Hz
Phase Single-Phase
Power Supply Circuit 20 Amps

A power supply circuit includes all electrical equipment between the breaker box or fuse panel in the building and the machine. The power supply circuit used for this machine must be sized to safely handle the full-load current drawn from the machine for an extended period of time. (If this machine is connected to a circuit protected by fuses, use a time delay fuse marked D.)

! CAUTION

For your own safety and protection of property, consult an electrician if you are unsure about wiring practices or electrical codes in your area.

Note: *Circuit requirements in this manual apply to a dedicated circuit—where only one machine will be running on the circuit at a time. If machine will be connected to a shared circuit where multiple machines may be running at the same time, consult an electrician or qualified service personnel to ensure circuit is properly sized for safe operation.*



Grounding & Plug Requirements

This machine **MUST** be grounded. In the event of certain malfunctions or breakdowns, grounding reduces the risk of electric shock by providing a path of least resistance for electric current.

This machine is equipped with a power cord that has an equipment-grounding wire and a grounding plug. Only insert plug into a matching receptacle (outlet) that is properly installed and grounded in accordance with all local codes and ordinances. **DO NOT** modify the provided plug!

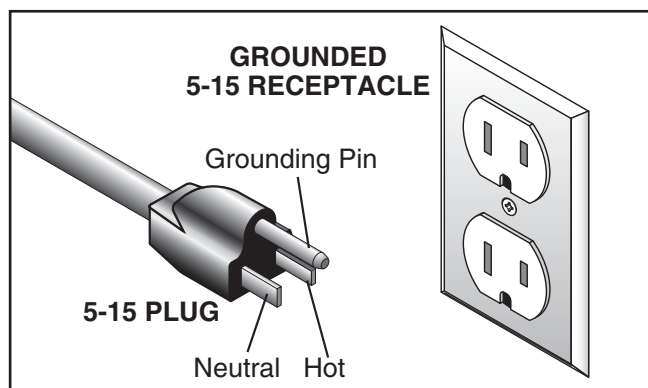

Figure 5. Typical 5-15 plug and receptacle.

⚠ CAUTION

SHOCK HAZARD!

Two-prong outlets do not meet the grounding requirements for this machine. Do not modify or use an adapter on the plug provided—if it will not fit the outlet, have a qualified electrician install the proper outlet with a verified ground.

Improper connection of the equipment-grounding wire can result in a risk of electric shock. The wire with green insulation (with or without yellow stripes) is the equipment-grounding wire. If repair or replacement of the power cord or plug is necessary, do not connect the equipment-grounding wire to a live (current carrying) terminal.

Check with a qualified electrician or service personnel if you do not understand these grounding requirements, or if you are in doubt about whether the tool is properly grounded. If you ever notice that a cord or plug is damaged or worn, disconnect it from power, and immediately replace it with a new one.

Extension Cords

We do not recommend using an extension cord with this machine. If you must use an extension cord, only use it if absolutely necessary and only on a temporary basis.

Extension cords cause voltage drop, which can damage electrical components and shorten motor life. Voltage drop increases as the extension cord size gets longer and the gauge size gets smaller (higher gauge numbers indicate smaller sizes).

Any extension cord used with this machine must be in good condition and contain a ground wire and matching plug/receptacle. Additionally, it must meet the following size requirements:

Minimum Gauge Size 14 AWG
Maximum Length (Shorter is Better).....50 ft.



SECTION 3: SETUP

Preparation

The list below outlines the basic process of preparing your machine for operation. Specific steps are covered later in this section.

The typical preparation process is as follows:

1. Unpack lathe and inventory contents of box/ crate.
2. Clean lathe and its components.
3. Identify and move lathe to acceptable location.
4. Assemble loose components and make any necessary adjustments or inspections to ensure lathe is ready for operation.
5. Connect lathe to power source.
6. Test run lathe to ensure it functions properly.
7. Perform spindle break-in procedure to prepare lathe for operation.

Unpacking

This machine was carefully packaged for safe transport. When unpacking, separate all enclosed items from packaging materials and inspect them for shipping damage. ***If items are damaged, please call us immediately at (570) 546-9663.***

IMPORTANT: Save all packaging materials until you are completely satisfied with the machine and have resolved any issues between Grizzly or the shipping agent. ***You MUST have the original packaging to file a freight claim. It is also extremely helpful if you need to return your machine later.***

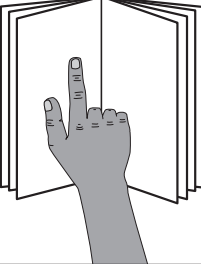
	<p>⚠️ WARNING This machine presents serious injury hazards to untrained users. Read through this entire manual to become familiar with the controls and operations before starting the machine!</p>
--	--

	<p>⚠️ WARNING Wear safety glasses during the entire setup process!</p>
--	---

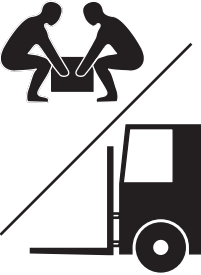
	<p>⚠️ WARNING HEAVY LIFT! Straining or crushing injury may occur from improperly lifting machine or some of its parts. To reduce this risk, get help from other people and use a forklift (or other lifting equipment) rated for weight of this machine.</p>
---	--

Needed for Setup

The following items are needed to complete the setup process, but are not included with your machine:

Description	Qty
• Assistant.....	1
• Safety Glasses	1 For Each Person
• Machinist's Level	1
• Lifting Straps (rated for at least 750 lbs)	2
• Power Lifting Equipment (rated for at least 750 lbs).....	As Needed
• Machine Mounting Hardware	As Needed
• NGLI #2 Grease	As Needed
• ISO 68 or Equivalent Lubricant ..	As Needed



Inventory

The following is a description of the main components shipped with your machine. Lay the components out to inventory them.

Note: *If you can't find an item on this list, check the mounting location on the machine or examine the packaging materials carefully. Occasionally we pre-install certain components for shipping purposes.*

Inventory (Figure 6)	Qty
A. Lathe 11" x 26" (not shown).....	1
B. Faceplate 8"	1
C. Toolbox	1
D. Steady Rest.....	1
E. Follow Rest.....	1
F. 4-Way Tool Post	1
G. 3-Jaw Chuck 5"	1
H. 4-Jaw Chuck 6½".....	1
I. 3-Jaw Chuck Key	1
J. Dead Center MT#4	1
K. External Jaws for 3-Jaw Chuck.....	3
L. Dead Center MT#3	1
M. Change Gears 28, 35, 63, 69, 70, 77, 78T	1 Each
N. Screwdrivers Standard/Phillips.....	1 Each
O. Spanner Wrench	1
P. Hex Wrenches 3, 4, 5, 6, 8mm	1 Each
Q. Wrenches 8/10, 12/14, 17/19mm.....	1 Each
R. 4-Jaw Chuck Key	1
S. V-belt 3L290 (not shown)	1
T. Splash Pan (not shown)	1

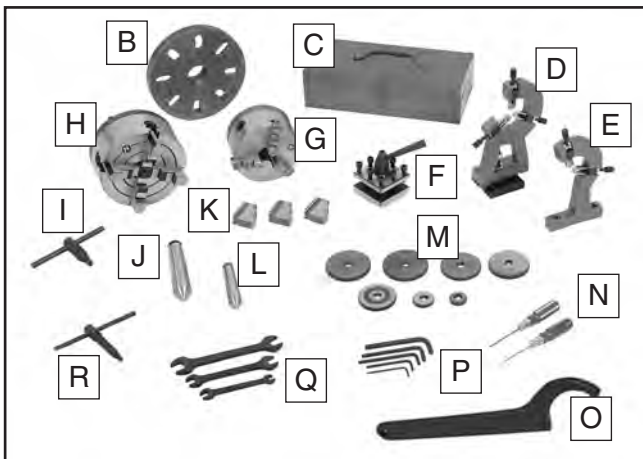

Figure 6. Model G9972Z inventory.

Cleanup

The unpainted surfaces of your machine are coated with a heavy-duty rust preventative that prevents corrosion during shipment and storage. This rust preventative works extremely well, but it will take a little time to clean.

Be patient and do a thorough job cleaning your machine. The time you spend doing this now will give you a better appreciation for the proper care of your machine's unpainted surfaces.

There are many ways to remove this rust preventative, but the following steps work well in a wide variety of situations. Always follow the manufacturer's instructions with any cleaning product you use and make sure you work in a well-ventilated area to minimize exposure to toxic fumes.

Before cleaning, gather the following:

- Disposable rags
- Cleaner/degreaser (WD•40 works well)
- Safety glasses & disposable gloves
- Plastic paint scraper (optional)

Basic steps for removing rust preventative:

1. Put on safety glasses.
2. Coat the rust preventative with a liberal amount of cleaner/degreaser, then let it soak for 5–10 minutes.
3. Wipe off the surfaces. If your cleaner/degreaser is effective, the rust preventative will wipe off easily. If you have a plastic paint scraper, scrape off as much as you can first, then wipe off the rest with the rag.
4. Repeat **Steps 2–3** as necessary until clean, then coat all unpainted surfaces with a quality metal protectant to prevent rust.

NOTICE

Avoid harsh solvents like acetone or brake parts cleaner that may damage painted surfaces. Always test on a small, inconspicuous location first.



Site Considerations

Floor Load

Refer to the **Machine Data Sheet** on **Page 6** for the weight and footprint specifications of your machine. Some residential floors may require additional reinforcement to support both the machine and operator. Make sure the workbench or stand you plan to use can safely handle the weight and vibration of the lathe and operational materials.

Placement Location

Consider existing and anticipated needs, size of material to be processed through each machine, and space for auxiliary stands, work tables or other machinery when establishing a location for your new machine. See **Figure 7** for the minimum working clearances.

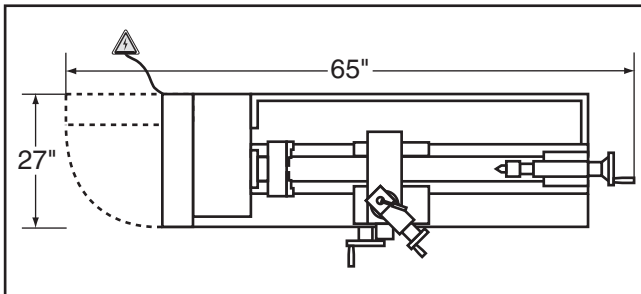
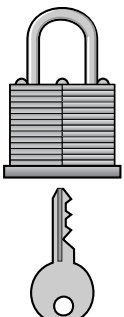
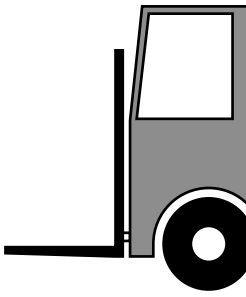

Figure 7. Minimum working clearances.

	<p>⚠ CAUTION</p> <p>Children and visitors may be seriously injured if unsupervised around this machine. Lock entrances to the shop or disable start switch or power connection to prevent unsupervised use.</p>
---	--

Moving & Placement

	<p>⚠ WARNING</p> <p>The Model G9972Z is a heavy machine. Serious personal injury may occur if safe moving methods are not used. To be safe, get assistance and use power equipment rated for at least 750 lbs. to move the shipping crate and remove the machine from the crate.</p>
--	---

To move and place your lathe:

1. Remove the top and side crating materials, and the chip pan, 4-jaw chuck, faceplate, and toolbox from the shipping pallet.
2. Position the chip pan on the selected mounting surface and use it as a template to prepare holes for the mounting hardware (refer to **Mounting** on **Page 17**).
3. Use the 17mm wrench to remove the hex nuts that secure the lathe to the shipping pallet.

<p>⚠ WARNING</p> <p>Only use lifting straps and power lifting equipment rated for at least 750 lbs. and in good working condition. If the lathe falls or tips over while moving it, serious personal injury and property damage could result.</p>
--



4. Wrap the lifting straps around the bed and between the leadscrew and the bedway, as shown in **Figure 8**.

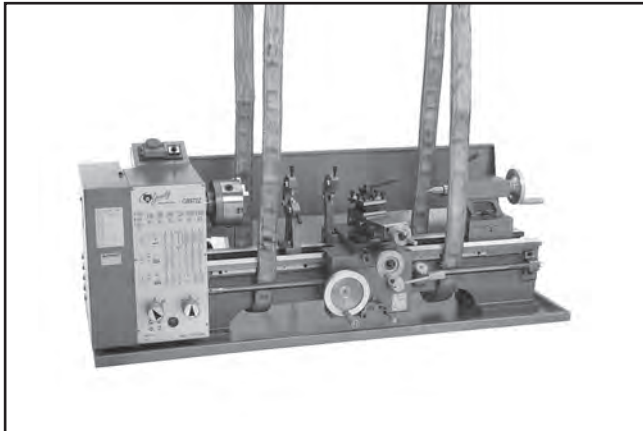

Figure 8. Lifting strap positions.

NOTICE

Make sure the lifting straps are between the leadscrew and bedway to avoid bending the leadscrew when lifting the lathe.

5. Position the lifting straps at either end of the bedway, then secure them to the lifting equipment.
6. With the help of an assistant to balance and steady the load, lift the lathe and place it on the chip pan with the mounting holes aligned.

Note: *If necessary, move the carriage or tailstock to help balance the load.*

7. To ensure accurate results from your lathe, use a machinist's precision level to make the lathe bedway exactly level from side-to-side and front-to-back. If necessary, use shims between the lathe and chip pan.

Note: *Re-check the bedway after 24 hours, after two weeks, then annually to make sure it remains level.*

Mounting

The strongest mounting option is a "Through Mount" where holes are drilled all the way through the workbench, and hex bolts, washers, and hex nuts are used to secure the lathe to the workbench, as illustrated in **Figure 9**.

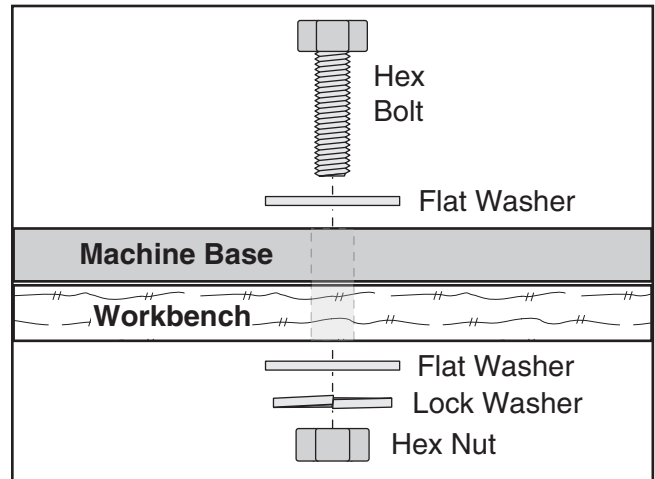

Figure 9. Example of a through mount setup.

Another option for mounting is a "Direct Mount" where the machine is simply secured to the workbench with a lag screw, as illustrated in **Figure 10**.

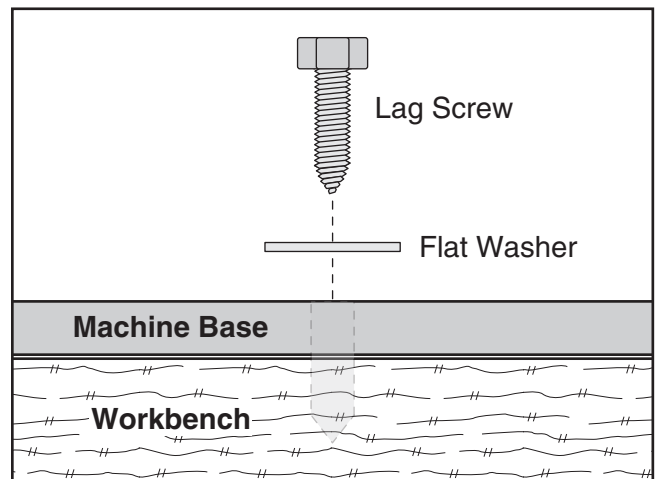

Figure 10. Example of a direct mount setup.

Note: *We recommend using a silicon sealant between the flat washers and the chip pan to avoid coolant or other fluids leaking through onto the bench or floor.*



Check Gearbox Oil

It is critical that you make sure there is oil in the feed rate gearbox before proceeding with the test run. Refer to the **Lubrication** instructions on **Page 51** for more details on which type of oil to use, how much to use, and where to put it.



Test Run

Once assembly is complete, test run the machine to ensure it is properly connected to power and safety components are functioning correctly.

If you find an unusual problem during the test run, immediately stop the machine, disconnect it from power, and fix the problem **BEFORE** operating the machine again. The **Troubleshooting** table in the **SERVICE** section of this manual can help.

The Test Run consists of verifying the following: 1) The motor powers up and runs correctly.

WARNING

Serious injury or death can result from using this machine **BEFORE** understanding its controls and related safety information. **DO NOT** operate, or allow others to operate, machine until the information is understood.

WARNING

DO NOT start machine until all preceding setup instructions have been performed. Operating an improperly set up machine may result in malfunction or unexpected results that can lead to serious injury, death, or machine/property damage.

To test run machine:

1. Clear all setup tools away from machine.
2. Perform all lubrication procedures as instructed in the **Lubrication** subsection on **Page 51**.



3. Move the half-nut lever up to disengage the half-nut, and push the power feed lever down to disengage the carriage power feed, as shown in **Figure 11**.

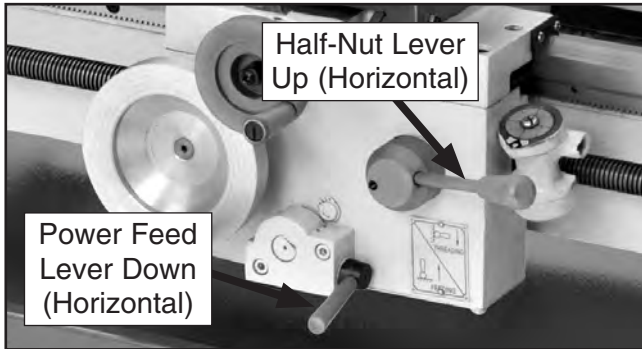

Figure 11. Half-nut and power feed lever positions for Test Run.

NOTICE

ALWAYS make sure the power feed lever and the half-nut lever are disengaged before starting the lathe to avoid carriage crashes with the headstock or tailstock.

4. Connect the machine to the power source.
5. Flip the spindle switch to the right "R" position—the spindle should rotate *counterclockwise* and the leadscrew should turn *clockwise*.
6. Lift the cover of the motor ON/OFF switch and turn the motor **ON**.

Note: Listen to and watch for abnormal noises or actions. The machine should run smoothly with little or no vibration or rubbing noises.

Strange or unusual noises should be investigated and corrected before operating the machine further. Always disconnect the machine from power when investigating or correcting potential problems.

7. Flip the spindle switch to the center "O" position and wait for the spindle to come to a complete stop.
8. Turn the spindle switch to the left "L" position—the spindle should rotate *clockwise* and the leadscrew should turn *counterclockwise*.
9. Press the red button on the motor ON/OFF switch.
 - If the motor stops, the emergency stop feature of the switch is working as designed.
 - If the motor does NOT stop, immediately disconnect the machine from power. The emergency stop feature is not working correctly. This safety feature must work properly before proceeding with regular operations. Call Tech Support for help.
10. After successfully completing all the **Test Run** steps, proceed to **Spindle Break-In**.



Spindle Break-In

The spindle break-in procedure distributes lubrication throughout the bearings to reduce the risk of early bearing failure if there are any "dry" spots or areas where lubrication has settled in the bearings. You **must** complete this procedure **before** placing operational loads on the spindle for the first time when the machine is new or if it has been sitting idle for longer than 6 months.

Always start the spindle break-in at the lowest speed to minimize wear if there *are* any dry spots. Allow the spindle to run long enough to warm up and distribute the bearing grease, then incrementally increase spindle speeds and repeat this process at each speed until reaching the maximum spindle speed. Following the break-in procedure in this progressive manner helps minimize any potential wear that could occur before lubrication is fully distributed.

NOTICE

You must complete this procedure to maintain the warranty. Failure to do this could cause rapid wear-and-tear of spindle bearings once they are placed under load.

1. DISCONNECT LATHE FROM POWER!
2. Make sure the lathe is properly lubricated (refer to **Lubrication** on **Page 51** for detailed instructions).
3. Configure the spindle belt for the lowest spindle speed (refer to **Spindle Speed** on **Page 39** for detailed instructions).
4. Connect the machine to power, turn the spindle switch to the "R" position to start spindle rotation in the counterclockwise direction, then let the lathe run for 10 minutes.
5. Stop the spindle rotation and wait until the spindle has come to a complete stop.
6. Start spindle rotation in the opposite clockwise direction and let the lathe run for 10 minutes.
7. Disconnect the machine from power, then repeat **Steps 4–6** for each of the spindle speeds.
8. Turn the lathe **OFF**. The spindle break-in is complete and your lathe is ready for operation.



Carriage Lock

The carriage is supplied with a lock bolt on the front right-hand side of the saddle (see **Figure 12**). This bolt locks the carriage in place for increased rigidity when making face cuts. This lock bolt must be loosened before attempting to move the carriage manually or with the power feed.

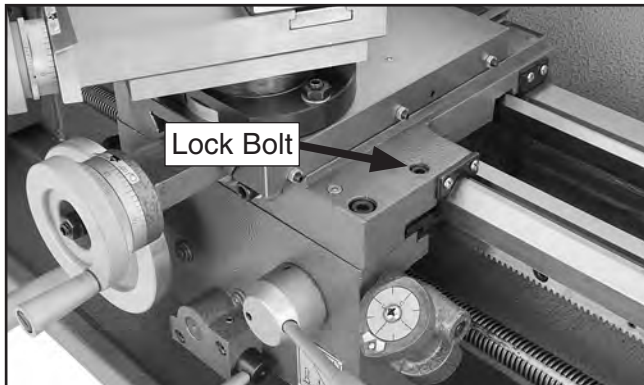

Figure 12. Carriage lock bolt.

Recommended Adjustments

For your convenience, the adjustments listed below have been performed at the factory.

However, because of the many variables involved with shipping, we recommend that you at least verify the following adjustments to ensure the best possible results from your new machine.

Step-by-step instructions for these adjustments can be found in the **SERVICE** section starting on **Page 55**.

Factory adjustments that should be verified:

- Cross slide backlash adjustment (**Page 58**)
- Gib adjustments (**Page 59**)



SECTION 4: OPERATIONS

Operation Overview

The purpose of this overview is to provide the novice machine operator with a basic understanding of how the machine is used during operation, so the machine controls/components discussed later in this manual are easier to understand.

Due to the generic nature of this overview, it is **not** intended to be an instructional guide. To learn more about specific operations, read this entire manual, seek additional training from experienced machine operators, and do additional research outside of this manual by reading "how-to" books, trade magazines, or websites.

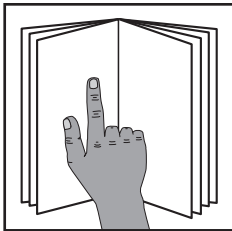

!WARNING

To reduce your risk of serious injury, read this entire manual **BEFORE** using machine.

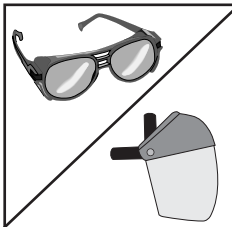

!WARNING

To reduce risk of eye injury from flying chips always wear safety glasses or face shield when operating.

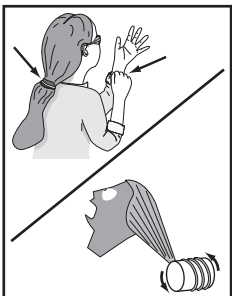

!WARNING

Keep hair, clothing, and jewelry away from moving parts at all times. Entanglement can result in death, amputation, or severe crushing injuries!

NOTICE

Complete the Test Run & Break-In procedure on Pages 18–20 before using this lathe for any cutting or threading operations; otherwise, gear box damage will occur.

NOTICE

If you are not experienced with this type of machine, **WE STRONGLY RECOMMEND** that you seek additional training outside of this manual. Read books/magazines or get formal training before beginning any projects. Regardless of the content in this section, Grizzly Industrial will not be held liable for accidents caused by lack of training.

To complete a typical operation, the operator does the following:

1. Puts on safety glasses, rolls up sleeves, removes jewelry, and secures any clothing, jewelry, or hair that could get entangled in moving parts.
2. Examines workpiece to make sure it is suitable for turning, then securely mounts workpiece in chuck, between centers, or on faceplate.
3. Mounts tooling, aligns it with workpiece, then backs it away to establish safe startup clearance.
4. Clears all setup tools from lathe.
5. Checks for safe clearances by rotating workpiece by hand at least one full revolution.
6. Sets correct spindle speed for the operation.
7. If using power feed, selects the proper feed rate for the operation.
8. Starts spindle rotation, then engages half nut.
9. Uses various carriage controls to move the tooling into the workpiece for operations.
10. When finished cutting, disengages the half nut (power feed only), moves the spindle direction switch to the OFF position, waits for the spindle to completely stop, then removes the workpiece.



Chuck & Faceplate Mounting

This lathe is equipped with a threaded spindle nose. With this type of spindle, a chuck or faceplate is screwed directly onto the spindle nose.

!WARNING

Never use spindle speeds faster than the chuck RPM rating or the safe limits of your workpiece. Excessive spindle speeds greatly increase the risk of the workpiece or chuck being thrown from the machine with deadly force!

This lathe ships with the 5" 3-jaw chuck installed. This is a scroll-type chuck where all three jaws move in unison when the chuck key is used.

The included 6½" 4-jaw chuck features independent jaws, which are used for square or unevenly-shaped stock, and to mount work that needs to be adjusted to near zero total indicated runout.

If neither chuck can hold your workpiece, the cast iron 8" faceplate has slots for T-bolts that hold standard or custom clamping hardware. With the correct clamping hardware, a faceplate offers a wide range of uses, including machining non-concentric workpieces, straight turning between centers, off-center turning, and boring.

Both the chucks and the faceplate mount to the threaded spindle in the same manner.

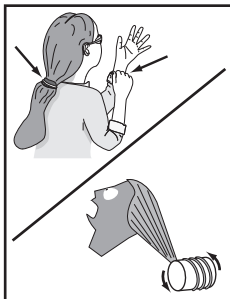

!WARNING

Keep hair, clothing, and jewelry away from moving parts at all times. Entanglement can result in death, amputation, or severe crushing injuries!

Installation & Removal Devices

Because chucks are heavy and often awkward to hold, some kind of support or protective device should be used during installation or removal. The weight and size of the chuck will determine the appropriate device to use (refer to the following figure for examples).

!WARNING

A dropped chuck can cause amputation, serious crushing injuries, or property damage. Always use a support or protective device to reduce this risk when installing or removing a chuck.

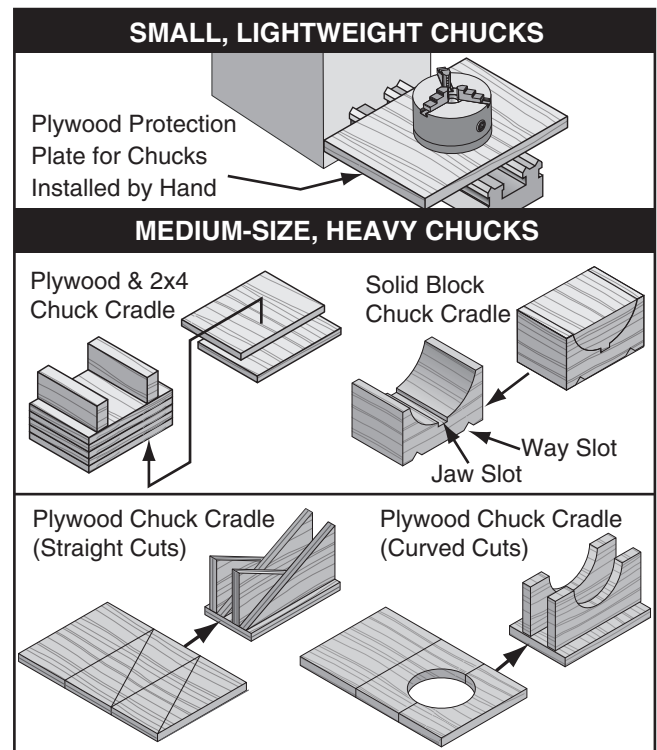

Figure 13. Examples of common devices used during chuck installation and removal.



Chuck Installation

To ensure accurate work, it is extremely important to make sure the spindle nose and chuck mating surfaces are clean. Even a small amount of lint or debris can affect accuracy.

The chuck is properly installed when it threads all the way onto the spindle nose (see **Figure 14** below) and is seated against the spindle shoulder.

There are two chucks included with the Model G9972Z: a 3-jaw and 4-jaw. A chuck key has been included for each.

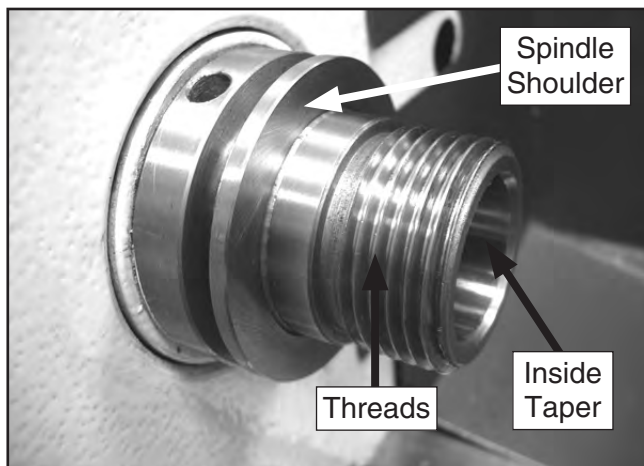

Figure 14. Spindle nose.

Tools Needed	Qty
Hex Wrench 5mm.....	1
Chuck Key (3- or 4-Jaw).....	As Needed
Spanner Wrench.....	1

To install the chuck:

1. DISCONNECT LATHE FROM POWER!
2. Use an appropriate device to protect the ways and support the chuck during the installation process (refer to **Installation & Removal Devices** on **Page 23**).
3. Thoroughly clean, inspect, deburr, and lightly oil all threads and mating surfaces.
4. Thread the chuck onto the spindle nose and hand-tighten it.

5. Insert spanner wrench and tighten chuck with chuck key until it is seated snug against the spindle shoulder as shown in **Figure 15**.

Note: Overtightening chuck will make removal difficult and could damage threads.

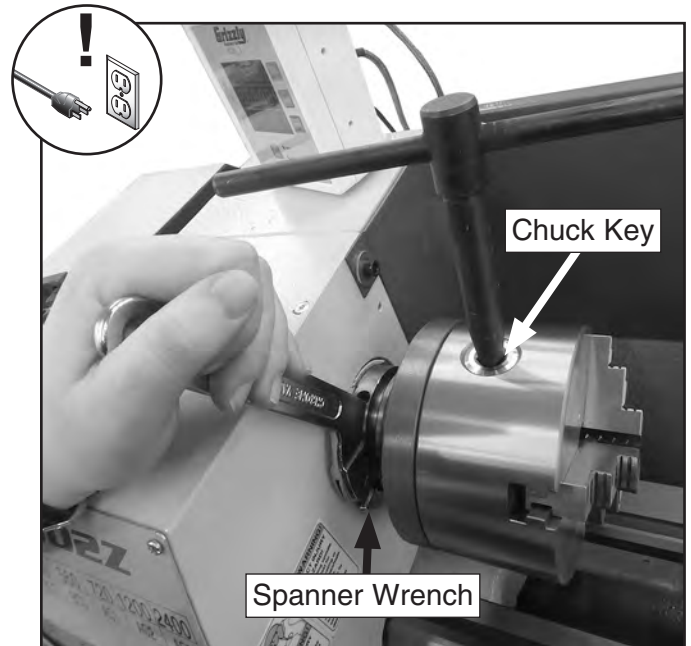

Figure 15. Example of using chuck key and spanner wrench to tighten chuck onto spindle.

6. Position spindle clamps as shown in **Figure 16**, then secure with cap screws.

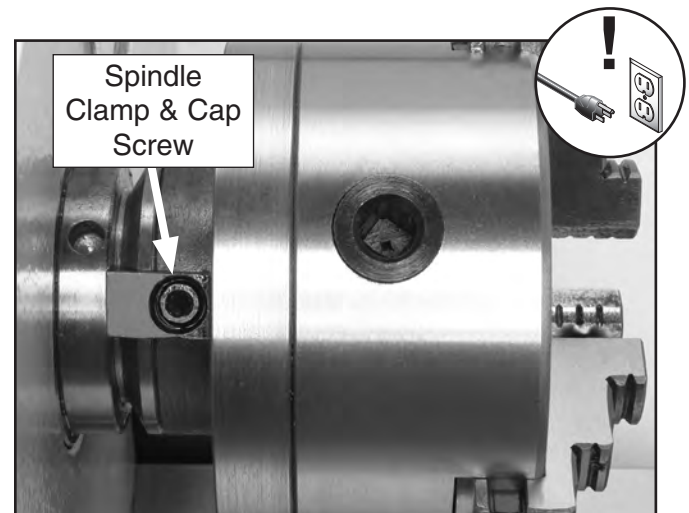
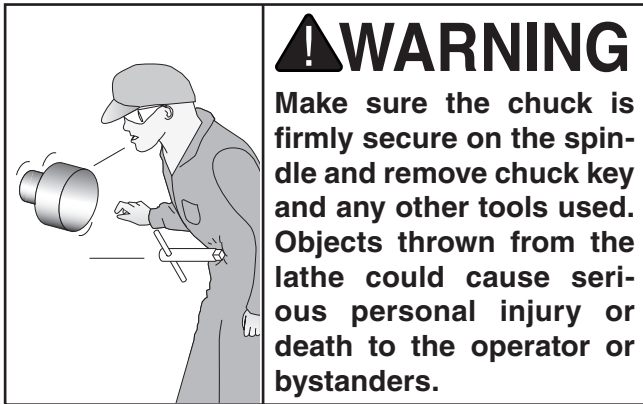

Figure 16. Spindle clamp and cap screw securing chuck/faceplate to spindle.



- Remove the chuck cradle or plywood and any tools used before starting the lathe.



- Insert spanner wrench into spindle indent, as shown in **Figure 18**, then support and unthread the chuck from spindle using chuck key.

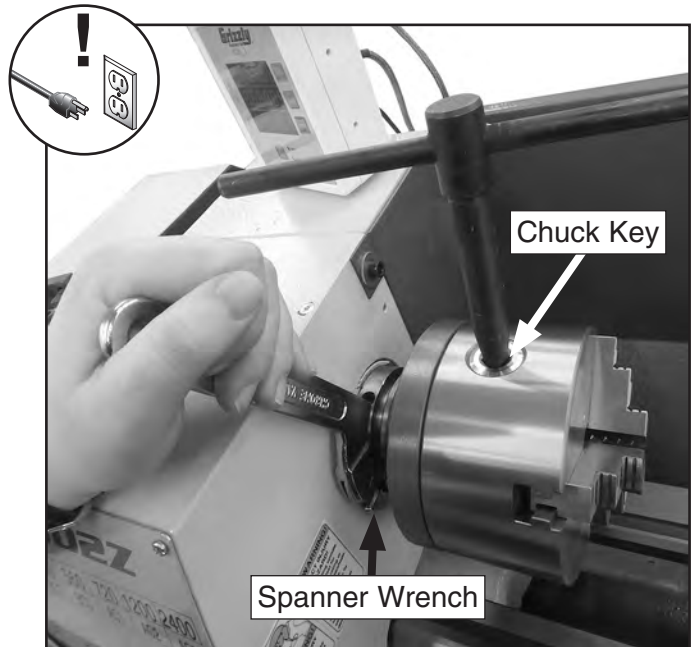

Figure 18. Example of using chuck key and spanner wrench to tighten chuck onto spindle.

Chuck Removal

Tools Needed:	Qty
Spanner Wrench.....	1
Chuck Key (3- or 4-Jaw).....	1
Hex Wrench 5mm.....	1

To remove the chuck:

- DISCONNECT LATHE FROM POWER!
- Use an appropriate device to protect the ways and support the chuck (refer to **Installation & Removal Devices** on **Page 23**).
- Remove both spindle clamps from behind the chuck or faceplate (see **Figure 17**).

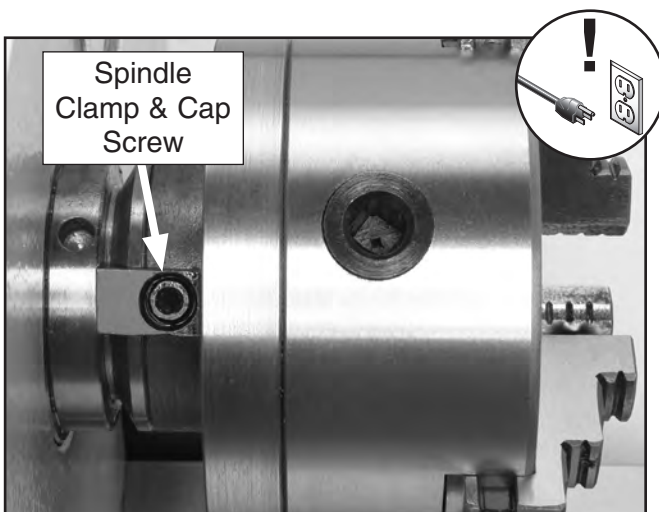

Figure 17. Spindle clamp and cap screw securing chuck/faceplate to spindle.



Changing Jaw Set

Tools Needed:	Qty
Chuck Wrench.....	1

The 3-jaw scroll chuck included with the lathe features inside and outside hardened steel jaw sets (see **Figure 19**), which move in unison to center a concentric workpiece.

When installing the jaws, it is important to make sure they are installed correctly. Incorrect installation will result in jaws that do not converge evenly and are unable to securely clamp a workpiece.

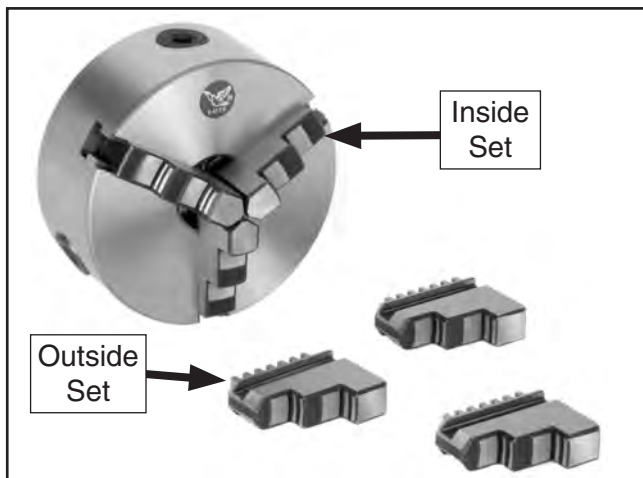

Figure 19. Chuck and jaw selection.

Jaws are numbered from 1–3 (see **Figure 20**). They are designed to be installed in numerical order in the jaw guides so they will hold a concentric workpiece evenly.

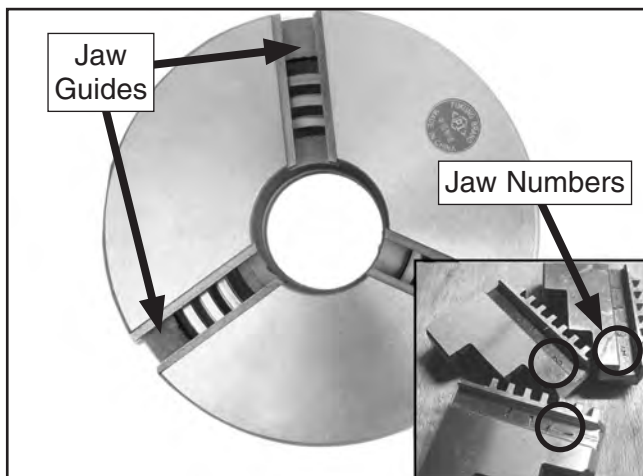

Figure 20. Jaw guide and jaw numbers.

To change the jaw set:

1. DISCONNECT LATHE FROM POWER!
2. Place a piece of plywood over the bedways to protect them from potential damage.
3. Insert the chuck key and turn it counterclockwise to back the jaws out and remove them.
4. Use mineral spirits to clean the debris and grime from the jaws and chuck jaw guides.
5. Apply a thin coat of white lithium grease to the surfaces of the removed jaw set. Store in a safe place free from moisture and abrasives.
6. Rotate the chuck key clockwise until you see the tip of the scroll-gear lead thread just begin to enter a jaw guide (see **Figure 21**).

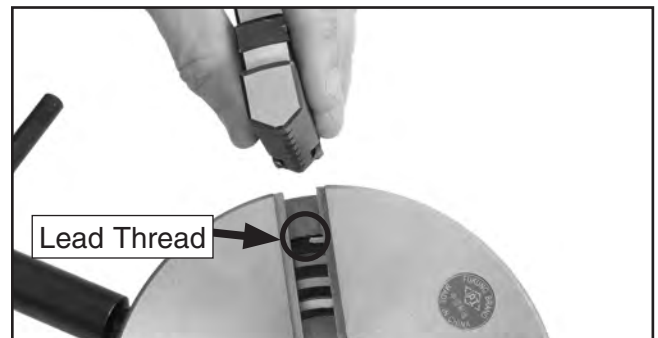

Figure 21. Lead thread on scroll gear.

7. Insert jaw #1 into the jaw guide and hold the jaw against the scroll-gear.
8. Rotate the chuck key clockwise one turn to engage the tip of the scroll-gear lead thread into the jaw. Pull the jaw; it should be locked into the jaw guide.
9. Install the remaining jaws in numerical order, in the same manner.
 - If installed correctly, the jaws will converge evenly at the center of the chuck.
 - If the jaws do not converge evenly, remove them. Re-install the jaws sequentially 1–3, and make sure each one engages with the scroll-gear lead thread during its first rotation.



Scroll Chuck Clamping

The 3-jaw scroll-type chuck has an internal scroll-gear that moves all jaws in unison when adjusted with the chuck key. The chuck will hold cylindrical parts on-center with the axis of spindle rotation and can be rotated at high speeds if the workpiece is properly clamped and balanced.

Never mix jaw types or positions to accommodate an odd-shaped workpiece. The chuck will spin out of balance and may throw the workpiece! Instead, use an independent jaw chuck or a faceplate.

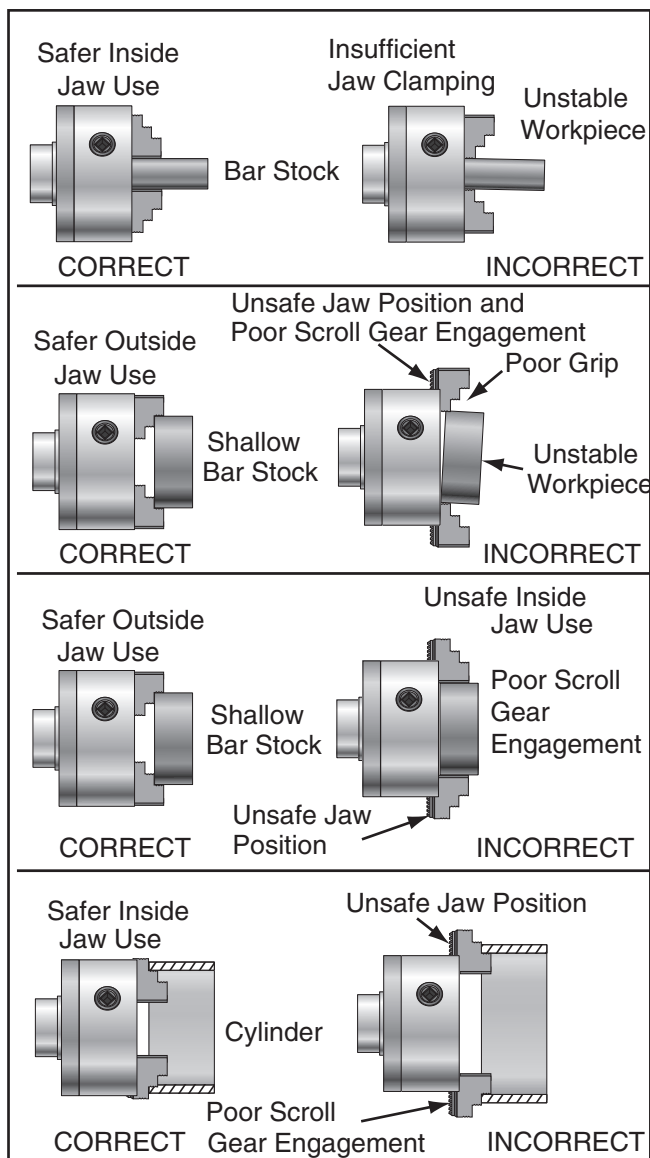

Figure 22. Jaw selection and workpiece holding.

4-Jaw Chuck

Refer to the **Chuck Installation** (see **Page 24**) and **Chuck Removal** (see **Page 25**) instructions to install or remove the 4-jaw chuck.

The 4-jaw chuck features independently adjustable hardened steel jaws for holding non-concentric or off-center workpieces. Each jaw can be independently removed from the chuck body and reversed for a wide range of work holding versatility.

⚠️ WARNING

Because of the dynamic forces involved in machining a non-concentric or off-center workpiece, always use a low spindle speed to reduce risk of the workpiece coming loose and being thrown from the lathe, which could cause death or serious personal injury.

Tools Needed:	Qty
4-Jaw Chuck Key	1
Dial Indicator	1

To mount the workpiece:

1. DISCONNECT LATHE FROM POWER!
2. Place a chuck cradle or plywood on the bedway below the chuck to protect the bedway surfaces.
3. Use the chuck key to open each jaw so the workpiece will lay flat against the chuck face, jaw steps, or into the spindle opening.
4. With help from another person or a holding device, position the workpiece so it is centered in the chuck.



5. Tighten each jaw in small increments. After you have adjusted the first jaw, continue tightening the remaining jaws in an opposing sequence, as shown by the sequential order in **Figure 23**.

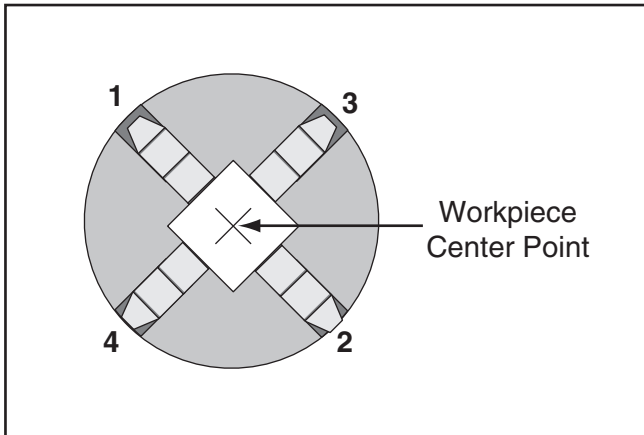

Figure 23. 4-jaw tightening sequence.

6. After the workpiece is held in place by the jaws, use a dial indicator to make sure the workpiece is centered in the chuck.

— If the workpiece is not correctly centered, make fine adjustments by slightly loosening one jaw and tightening the opposing jaw until the workpiece is correctly positioned (see **Figure 24** for an example).



Figure 24. Generic picture of non-cylindrical workpiece correctly mounted on the 4-jaw chuck.

Faceplate

Refer to the **Chuck Installation** (see **Page 24**) and **Chuck Removal** (see **Page 25**) instructions to install or remove the faceplate.

The faceplate included with your lathe can be used for a wide range of operations, including machining non-concentric workpieces, straight turning between centers, off-center turning, and boring.

The tools needed for mounting a workpiece will vary depending on the type of setup you have.

!WARNING

Machining non-concentric workpieces at a high speed could cause the workpiece to be thrown from the spindle with deadly force at the operator or bystanders. To reduce this risk, only machine non-concentric workpieces at low speeds and clamp counter-weights to faceplate to balance it.

!WARNING

Failure to properly secure a workpiece to the faceplate could cause the workpiece to be thrown from the lathe with deadly force at the operator or bystanders. Use a minimum of THREE independent clamping devices to hold the workpiece onto the faceplate.

To mount a non-concentric workpiece to the faceplate:

1. DISCONNECT LATHE FROM POWER!
2. Protect the bedway with a piece of plywood.



3. With help from another person or a holding device to support the workpiece, position it onto the faceplate and clamp it in place with a minimum of three independent clamping devices (see **Figure 25** for an example).

Be sure to take into account the rotational and cutting forces that will be applied to the workpiece when clamping it to the faceplate. If necessary, use counter-weights to balance the assembly and use a dial indicator to make sure that the workpiece is properly positioned for your operation.

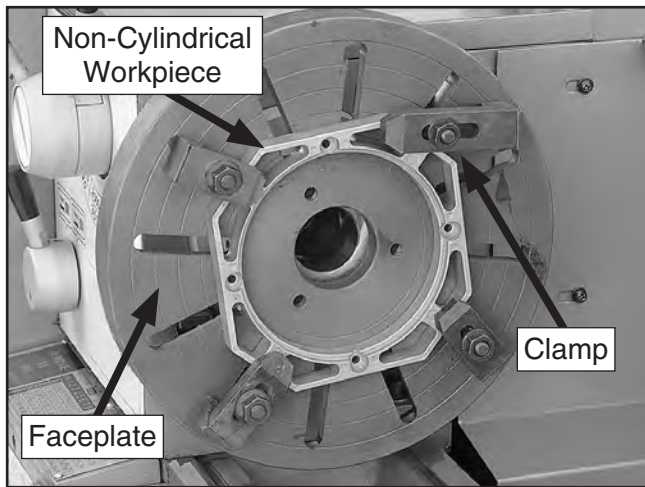

Figure 25. Generic picture of workpiece clamped in a faceplate.

Tailstock

The tailstock (see **Figure 26**) is typically used to support long workpieces by means of a live or dead center (refer to **Centers** on **Page 33**). It can also be used to hold a drill or chuck to bore holes in the center of a part. Custom arbors and tapers can also be cut on your lathe by using the offset tailstock adjustment.

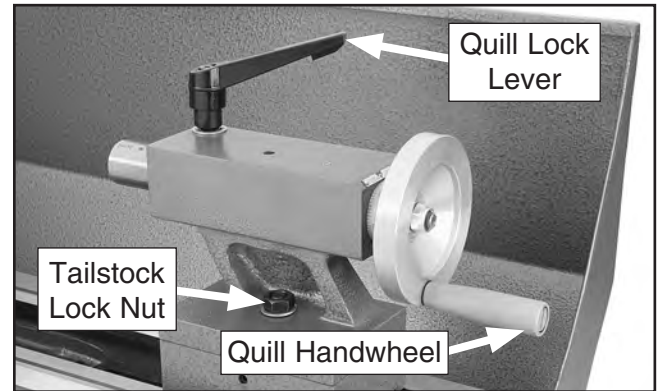

Figure 26. Tailstock and quill lock handles in locked position.

Graduated Dial

Increments.....	0.001"
One Full Revolution.....	0.060"

Increments on Quill

Inch	0"-2½" in ⅛" Increments
Metric.....	0–65mm in 1mm Increments

Positioning Tailstock

1. Loosen tailstock lock nut to unlock the tailstock from the bedway.
2. Slide the tailstock to the desired position.
3. Tighten the tailstock lock nut to lock the tailstock against the bedway.

Using Quill

1. Loosen the quill lock lever.
2. Turn quill handwheel clockwise to move quill toward spindle or counterclockwise to move it away from it.
3. Tighten the quill lock lever.



Installing Tooling

This tailstock uses a quill with an MT#3 taper that accepts a variety of tapered arbors and tooling, including tang arbors and drill bits (see **Figures 27–28** for examples).

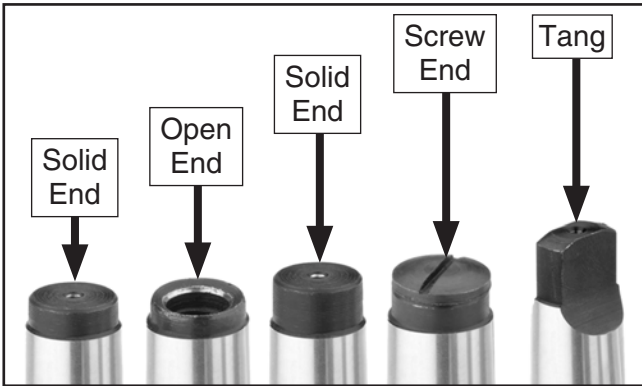

Figure 27. Types of tapered arbors and tooling.

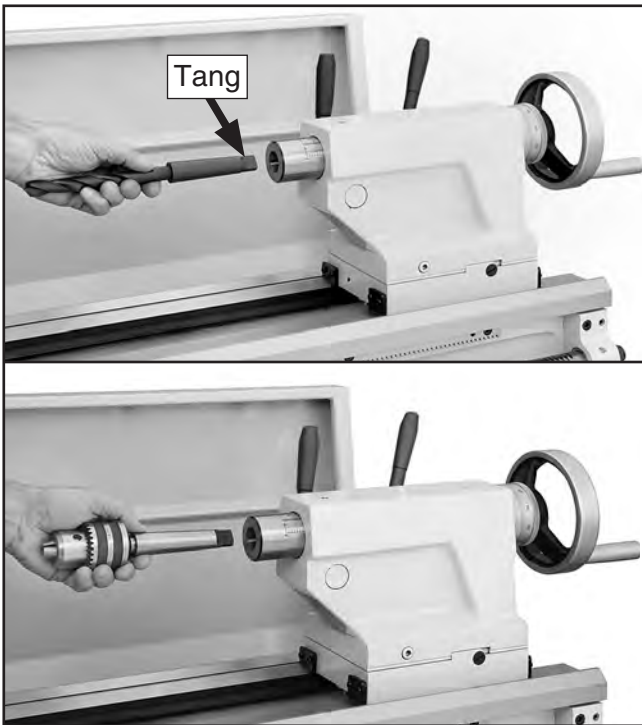

Figure 28. Example photos of inserting MT#3 tools with tangs into a typical tailstock.

Note: If the tooling has an open hole in the end, then a screw can be threaded into the end of the tool to provide a solid surface for the quill pin to push against when the quill is retracted for tool removal. Otherwise, removal of such tooling may be difficult.

To install tooling in the tailstock:

1. With the tailstock locked in place, unlock the quill, then use the handwheel to extend it approximately 1".
2. Thoroughly clean and dry the tapered mating surfaces of the quill and the center, making sure that no lint or oil remains on the tapers.
3. With a firm and quick motion, insert the tool into the quill, as shown in **Figure 28** on **on this page**. Check to see if it is firmly seated by attempting to twist it—a firmly seated tool will not twist.
4. Unlock the tailstock and move it until the tip of the tool is close to, but not touching, the workpiece, then re-lock the tailstock.
5. Start spindle rotation, unlock the quill lock lever, then turn the quill handwheel clockwise to feed the tool into the workpiece.

Removing Tooling

1. Use a shop rag to hold the tool.
2. Rotate the quill handwheel counterclockwise until the tool is forced out of the quill.

Offsetting Tailstock

The tailstock can be offset from the spindle centerline for turning tapers. Move the tailstock top casting toward the front of the lathe to machine a taper at the tailstock end. Conversely, position the tailstock top casting toward the back of the lathe to machine a taper at the spindle end.

Note: The marks on the offset indicator are arbitrary. For a precise offset, use a dial indicator to check quill movement while adjusting the screws.

Tools Needed

	Qty
Hex Wrench 4mm.....	1
Open-End Wrench 19mm.....	1



To offset the tailstock:

1. Loosen the tailstock lock nut (see **Figure 29**).

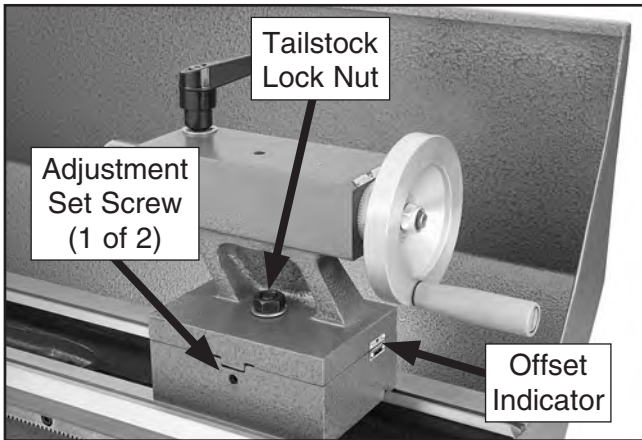

Figure 29. Left offset adjustment.

2. Rotate the adjustment set screws in opposite directions for the desired offset (see the illustration in **Figure 30**).

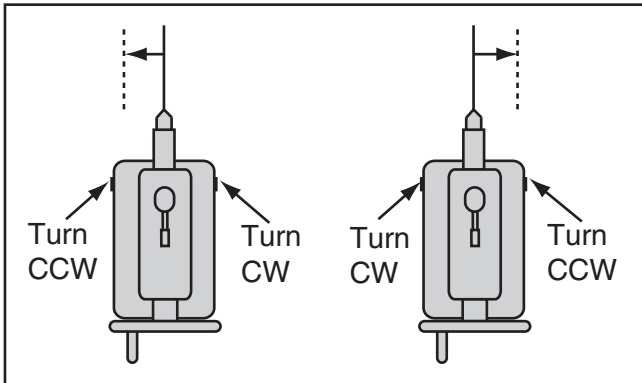

Figure 30. Set screw adjustment in relation to tailstock movement.

3. Retighten the tailstock lock nut to secure the offset.

Aligning Tailstock to Spindle Centerline

This is an essential adjustment that should be verified or performed each time the tailstock is used to turn concentric workpieces between centers or immediately after offsetting the tailstock when turning a taper. If the tailstock is not aligned with the spindle centerline when it is supposed to be, turning results will be inaccurate along the length of the workpiece.

Items Needed	Qty
Hex Wrench 4mm.....	1
Open-End Wrench 19mm.....	1
Round Stock 2" x 6"	2
Precision Level	1
Precision Calipers	1
Dial Indicator	1

To align the tailstock to the spindle centerline:

1. Use the precision level to make sure the bedway is level from side-to-side and from front-to-back.
 - If the bedway is not level, correct this condition before continuing (refer to **Leveling & Mounting** on **Page 17**).
2. Center drill both ends of one piece of round stock, then set it aside for use in **Step 5**.
3. Use the other piece of round stock to make a dead center, and turn it to a 60° point, as illustrated in **Figure 31**.

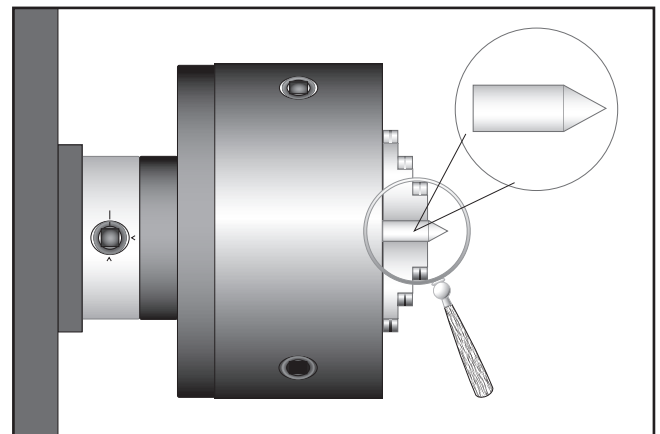

Figure 31. Turning a dead center.



Note: As long as this dead center remains in the chuck, the point of the center will remain true to the spindle centerline. The point will have to be refinished whenever the center is removed and then returned to the chuck.

4. Install a center in the tailstock.
5. Attach a lathe dog to the test stock from **Step 2**, then mount it between the centers (see **Figure 32** for an example).



Figure 32. Example photo of stock mounted between the centers.

6. Turn 0.010" off the stock diameter.
7. Mount a test or dial indicator so that the plunger is on the tailstock quill.

Note: If necessary in the following step, refer to **Offsetting Tailstock** on **Page 30** for detailed instructions.

8. Use calipers to measure both ends of the workpiece.

— If the test stock is *thicker* at the tailstock end, move the tailstock toward the *front* of the lathe $\frac{1}{2}$ the distance of the amount of taper (see **Figure 33**).

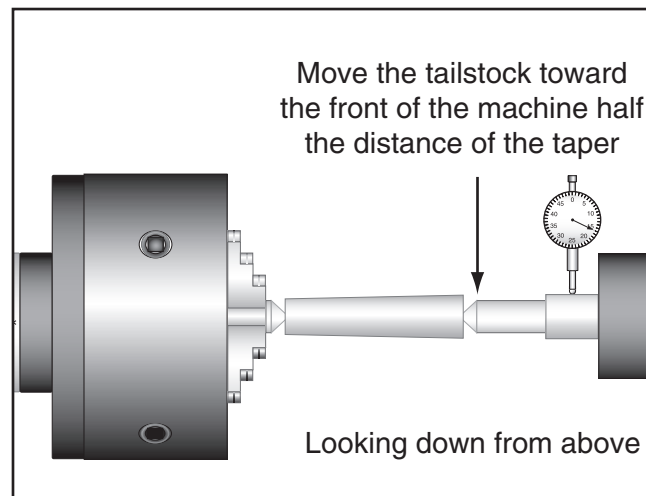

Figure 33. Adjust tailstock toward the operator.

— If the test stock is *thinner* at the tailstock end, move the tailstock toward the *back* of the lathe $\frac{1}{2}$ the distance of the amount of taper (see **Figure 34**).

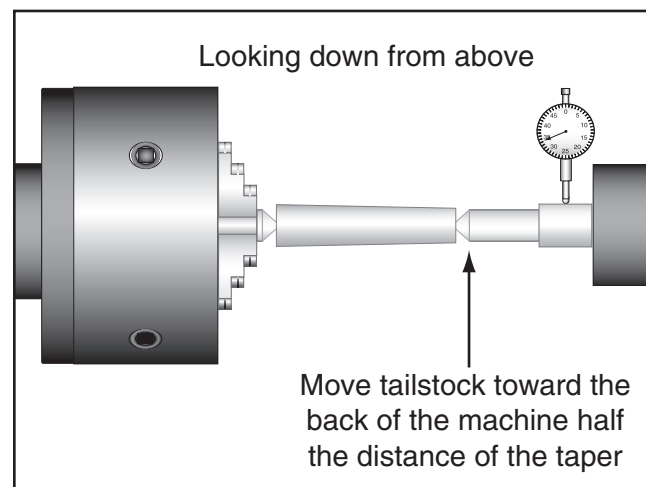

Figure 34. Adjust tailstock away from the operator.

9. Repeat **Steps 6–8** until the desired accuracy is achieved.



Centers

Figure 35 shows one of the two included MT#3 dead centers and the MT#4 dead center.

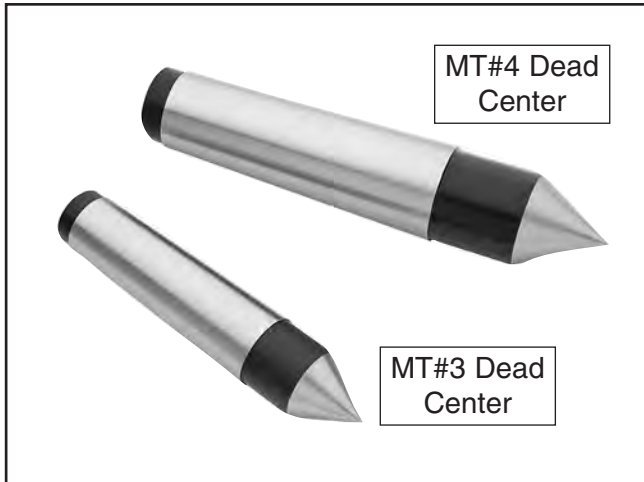

Figure 35. Dead centers.

The spindle taper is an MT#4 and will only receive the MT#4 dead center. The tailstock quill taper is an MT#3 and will only receive the MT#3 dead centers.

Dead Centers

A dead center is a one-piece center that does not rotate with the workpiece and is used to support long, slender workpieces in the tailstock.

A carbide-tipped dead center (not included) can better withstand the effects of friction than a typical dead center and is best used in the tailstock where the workpiece will rotate against it. The tip of a dead center must be generously lubricated during the operation to avoid premature wear and maximize smooth operation. Using low spindle speeds will also reduce the heat and wear from friction.

Use the dead center in the spindle for operations where the workpiece rotates with the center and does not generate friction.

Live Centers

A live center (not included) has bearings that allow the center tip and the workpiece to rotate together; it can be installed in the tailstock quill for higher speeds.

Mounting Dead Center in Spindle

1. DISCONNECT LATHE FROM POWER!
2. Thoroughly clean and dry all threads and mating surfaces of the spindle bore and the center, making sure that no lint or oil remains on these surfaces.

Note: *This will prevent the tapered surfaces from seizing due to operational pressures, which could make it very difficult to remove the center.*

3. Mount a chuck or faceplate onto the spindle, whichever is correct for your operation.
4. Insert the center into the spindle bore through the chuck or faceplate.

Figure 36 shows an example photo of a dead center installed in the spindle, using a lathe dog and faceplate for turning between centers.

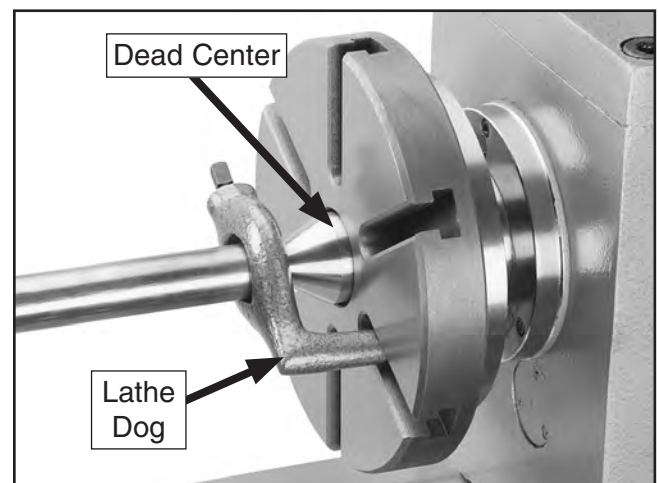

Figure 36. Example photo of using a dead center with a faceplate and lathe dog.



Removing Center from Spindle

To remove the center from the spindle, insert a piece of round bar stock or similar tool through the outboard end (on the left side of the headstock). Have another person hold onto the center with a gloved hand or shop rag, then tap the center loose.

Mounting Center in Tailstock

The included dead center or a live center can be used in the tailstock. Mounting instructions are the same for both. **Figure 37** shows an example photo of a dead center mounted in a tailstock.

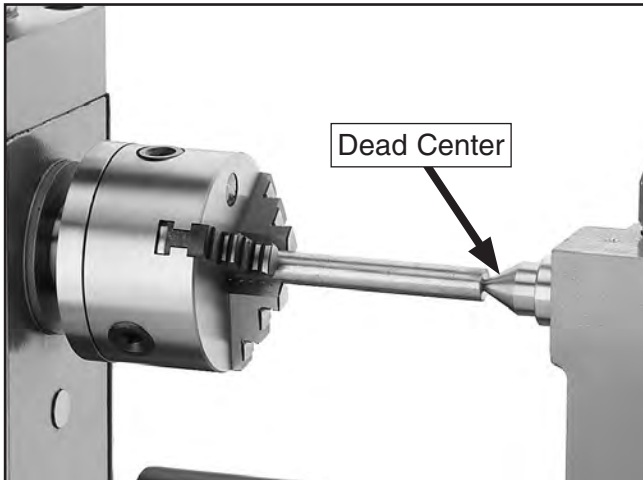

Figure 37. Example photo of using a dead center installed in the tailstock.

NOTICE

To avoid premature wear of the dead center or damage to the workpiece, use low spindle speeds and keep the tip of the dead center mounted in the tailstock well lubricated.

To mount a center in the tailstock:

1. DISCONNECT LATHE FROM POWER!
2. Thoroughly clean and dry the tapered mating surfaces of the tailstock quill bore and the center, making sure that no lint or oil remains on the tapers.

3. Use the quill handwheel to feed the quill out of the casting approximately 1" (see **Figure 38**).

Note: *The maximum quill travel is 2½", but we do not recommend extending the quill more than 2" or stability and accuracy will be reduced.*

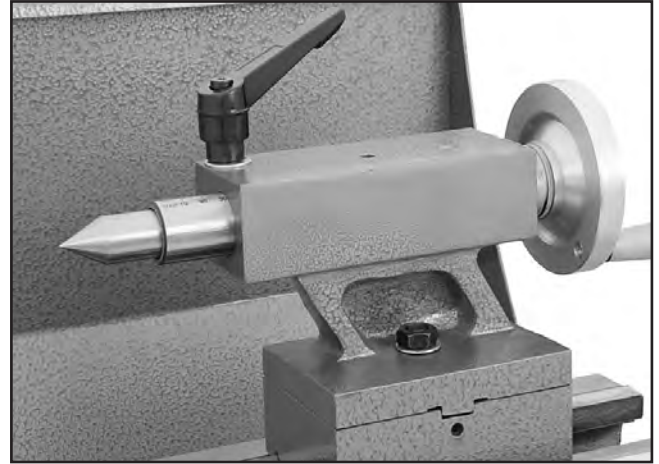

Figure 38. Dead center inserted into tailstock.

4. Insert the center into the tailstock quill.
5. Seat the center firmly into the quill during workpiece installation by rotating the quill handwheel clockwise to apply pressure, with the center engaged in the center hole in the workpiece.

Note: *Only apply enough pressure with the tailstock quill to securely mount the workpiece between centers. Avoid overtightening the center against the workpiece, or it may become difficult to remove later, and it will result in excessive friction and heat, which may damage the workpiece and center.*

6. Secure the quill lock lever and tailstock lock nut.

Removing Center from Tailstock

To remove the center from the quill, hold onto it with a gloved hand or shop rag, then rotate the quill handwheel counterclockwise to draw the quill back into the casting until the center releases.



Mounting Workpiece Between Centers

1. DISCONNECT LATHE FROM POWER!
2. Drill center holes in both ends of the workpiece.
3. Install a dead center in the spindle with a lathe dog and a chuck or faceplate, then install a live center or carbide-tipped dead center in the tailstock.
4. Lubricate the workpiece center holes, then mount the workpiece between the centers and hold it in place with light pressure from the tailstock center.
5. Seat the center firmly into the quill by rotating the quill handwheel clockwise to apply pressure against the workpiece (see the example in **Figure 39**).

Note: Only apply enough pressure to securely mount the workpiece between centers. Avoid over-tightening the center against the workpiece, or it may become difficult to remove later. Also, over-tightening will result in excessive friction and heat, which may damage the workpiece or center.



Figure 39. Example photo of a workpiece mounted between the centers.

6. Secure the quill lock lever and tailstock lock nut.

Steady Rest

The steady rest supports long shafts and can be mounted anywhere along the length of the bedway.

Familiarize yourself with the steady rest components shown in **Figure 40** to better understand its operation.

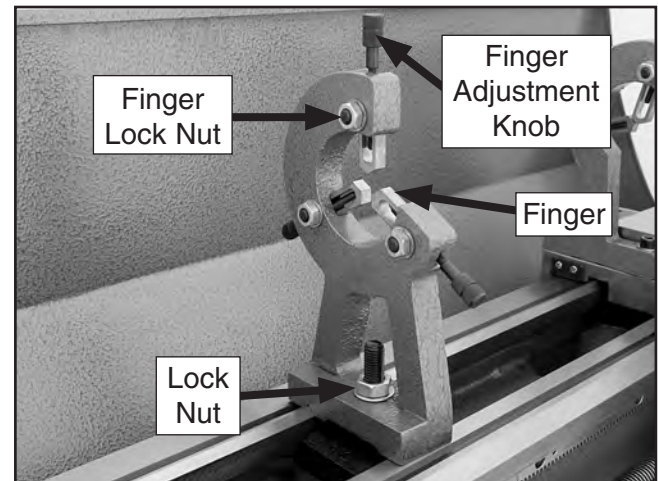

Figure 40. Steady rest components.

To install and use the steady rest:

1. DISCONNECT LATHE FROM POWER!
2. Thoroughly clean all mating surfaces, then place the steady rest base on the bedways so the triangular notch fits over the bedway prism.
3. Loosen the finger lock nuts shown in **Figure 40**, turn the finger adjustment knobs, and adjust the fingers as required for the workpiece.
4. Loosen the steady rest lock nut, position the steady rest where required to properly support the workpiece, then secure the lock nut.
5. Turn the finger adjustment knobs so the fingers are barely touching the workpiece, then tighten the finger lock nuts.
6. Lubricate the finger tips with an anti-seize lubricant during operation.

Note: Mill or file the tips if they show wear.



Follow Rest

The follow rest mounts to the saddle with two cap screws (see **Figure 41**). It is used on long, slender parts to prevent workpiece deflection from cutting tool pressure during operation. Adjust the follow rest fingers in the same manner as the those on the steady rest.

Note: *To reduce the effects of friction, lubricate the finger tips with generous anti-sieze lubricant during operation.*

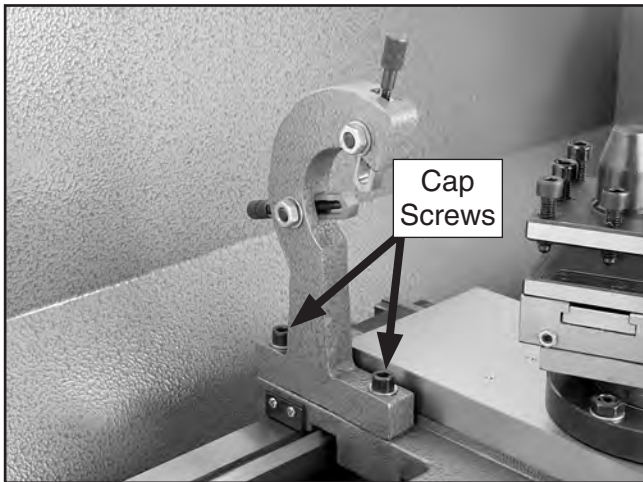

Figure 41. Follow rest attachment.

Compound Rest

The compound rest handwheel has an indirect-read graduated scale. This means the distance shown on the scale represents the actual distance the tool moves. The base of the compound rest has another graduated scale used for setting the cutting tool to a specific angle.

Graduated Dial

Increments..... 0.001" (0.025mm)
One Full Revolution 0.04" (1.02mm)

Tool Needed

Qty

Open-End Wrench 14mm..... 1

To set the compound rest at a certain angle:

1. Loosen the two hex nuts at the base of the compound rest (1 of 2 shown in **Figure 42**).

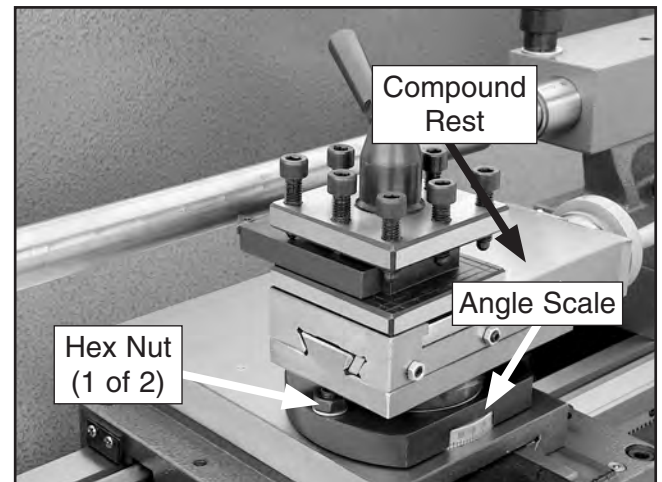

Figure 42. Compound rest.

2. Rotate the rest to the desired angle, as indicated by the scale at the base, then retighten the two hex nuts.

Tip: *The first time you set the angle of the compound rest for cutting threads, mark the location on the cross slide as a quick reference point. This will allow you to quickly return the compound rest to that exact angle the next time you need to cut threads.*



Four-Way Tool Post

The four-way tool post is mounted on top of the compound rest and allows a maximum of four 1/2" tools to be loaded simultaneously.

Each tool can be quickly indexed to the workpiece by loosening the top handle, rotating the tool post to the desired position, then re-tightening the handle to lock the tool into position.

Installing Tool

Tool Needed	Qty
Hex Wrench 6mm.....	1

To install a tool in the tool post:

1. Adjust the tool post screws so that the cutting tool can fit underneath them (see **Figure 43**).

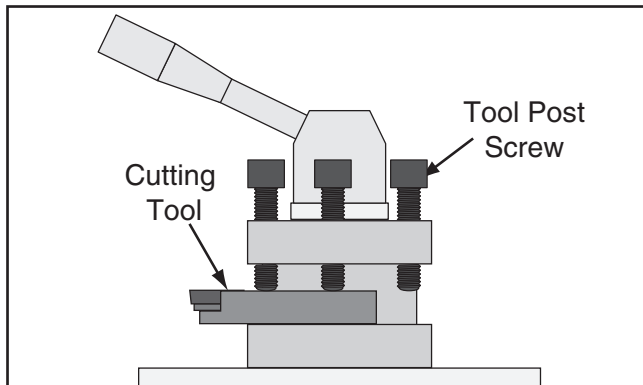

Figure 43. Example of tool mounted in tool post.

⚠WARNING

Over-extending a cutting tool from the post will increase the risk of tool chatter, breakage, or tool loosening during operation, which could cause metal pieces to be thrown at the operator or bystanders with great force. **DO NOT** extend a cutting tool more than 2.5 times the width of its cross-section (e.g., 2.5 x 0.5" = 1.25").

2. Firmly secure the cutting tool with at least two tool post screws.
3. Check and adjust the cutting tool to the spindle centerline, as instructed in the next subsection.

Aligning Cutting Tool with Spindle Centerline

For most operations, the cutting tool tip should be aligned with the spindle centerline, as illustrated in **Figure 44**.

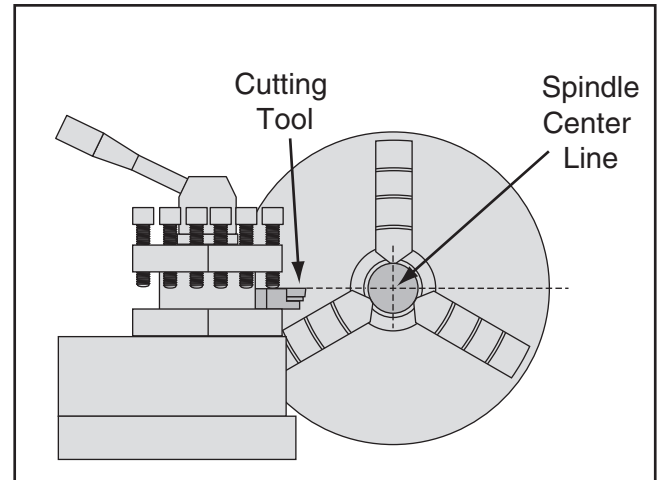

Figure 44. Cutting tool aligned with spindle centerline (viewed from tailstock).

There are a number of ways to check and align the cutting tool to the spindle centerline. If necessary, you can raise the cutting tool by placing steel shims underneath it. The shims should be as long and as wide as the cutting tool to properly support it.

Below are two common methods:

- Move the tailstock center over the cross slide and use a dial indicator to measure the distance from the surface of the cross slide to the tip of the center. Adjust the cutting tool height so it is the same distance above the cross slide as the tailstock center.
- Align the tip of the cutting tool with a tailstock center, as instructed in the following procedure. For this to work, the tailstock must be aligned to the spindle centerline (refer to **Aligning Tailstock To Spindle Centerline** on **Page 31** for detailed instructions).



Tools Needed	Qty
Hex Wrench 6mm.....	1
Steel Shims	As Needed
Cutting Tool	1
Tailstock Center.....	1

To align the cutting tool with the tailstock center:

1. Mount the cutting tool in the tool post, then secure the post so the tool faces the tailstock.
2. Install a center in the tailstock, and position the center tip near the cutting tool tip.
3. Lock the tailstock and quill in place.
4. Adjust the height of the cutting tool so that the tool tip is aligned vertically and horizontally with the center tip, as shown in **Figure 45**.

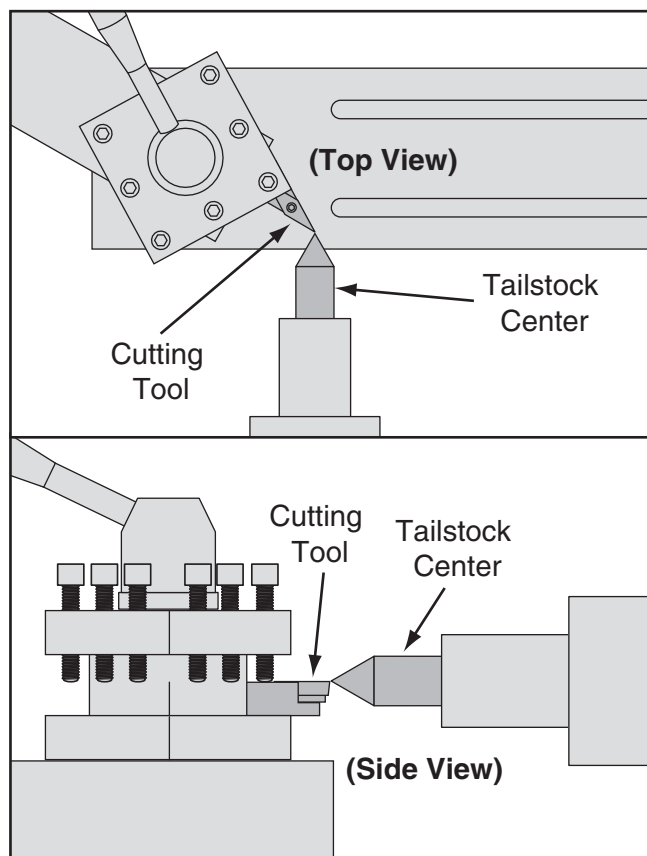

Figure 45. Cutting tool aligned to the tailstock center.

Manual Feed

The handwheels shown in **Figure 46** allow the operator to manually move the cutting tool.

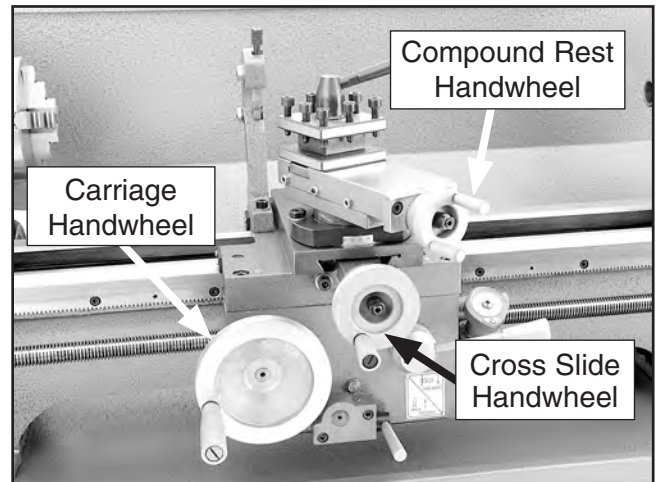

Figure 46. Manual handwheel controls.

Carriage Handwheel

Use the carriage handwheel to move the carriage left or right along the bed. This control is helpful when setting up the machine for turning or when manual movement is desired during turning operations.

Cross Slide Handwheel

Graduated Dial

Increments..... 0.001" (0.025mm)
 One Full Revolution..... 0.06" (1.52mm)

Use this to move the tool toward and away from the work. Adjust the position of the graduated scale by holding the handwheel with one hand and turning the dial with the other. The cross slide handwheel has an indirect-read graduated dial. This means the distance shown on the scale represents the actual distance the tool moves.

Compound Rest Handwheel

Graduated Dial

Increments 0.001" (0.025mm)
 One Full Revolution..... 0.04" (1.02mm)

Use this to move the cutting tool linearly along the set angle of the compound rest. Set the compound rest angle by hand-rotating it and securing in place with two hex nuts. The compound rest has an indirect-read graduated dial.



Spindle Speed

To set the correct spindle speed for your operation, you will need to: 1) Determine the spindle speed (RPM) needed for your workpiece material, and 2) configure the V-belt for the calculated spindle speed.

Calculating the Correct Spindle RPM

1. Use the table in **Figure 47** to determine the recommended cutting speed for the workpiece material.

Note: *Cutting speeds are expressed in surface feet per minute (SFM) that the cutter moves against the workpiece.*

Recommended Cutting Speeds		
Work Material	Average Tool Speed (sfm)	
	Rough Cuts	Finish Cuts
Magnesium	400	800
Aluminum	350	700
Brass & Bronze	250	500
Copper	100	250
Cast Iron (Soft)	100	250
Cast Iron (Hard)	50	150
Mild Steel	100	250
Cast Steel	70	150
Alloy Steels (Hard)	50	150
Tool Steel	50	150
Stainless Steel	60	180
Titanium	90	200
Hi Manganese Steel	40	100

Note: *These values are based on HSS cutting tools. For carbide cutting tools, double the average speed. These values are a guideline only. Refer to the MACHINERY'S HANDBOOK for more detailed information.*

Figure 47. Recommend cutting speed table.

2. Determine the final diameter, in inches, for the cut you intend to make.

Note: *For this step, you will need to average out the diameters or work with the finish diameter.*

3. Use the following formula to determine the correct spindle speed (RPM) for your operation:

$$\text{Dia. of Cut (in inches)} \times 3.14 \quad (\text{RPM})$$

*Double if using carbide cutting tool

Example A

You will finish cut 1/2" diameter piece of cast steel stock, using an HSS cutting tool.

Step 1:

$$150 \text{ (SFM from chart)} \times 4 = 600$$

Step 2:

$$600 / .5" \text{ (Diameter of workpiece)} = 1200$$

Result:

The correct spindle speed is 1200 RPM.

Example B

You will rough turn a 1" diameter piece of stainless steel, using a carbide cutting tool.

Step 1:

$$60 \text{ (SFM from chart)} \times 2 \text{ (for carbide tool)} = 120$$

Step 2:

$$120 \text{ (Determined SFM)} \times 4 = 480$$

Step 3:

$$480 / 1" \text{ (Diameter of workpiece)} = 480 \text{ RPM}$$

Result:

The correct spindle speed is 480 RPM.



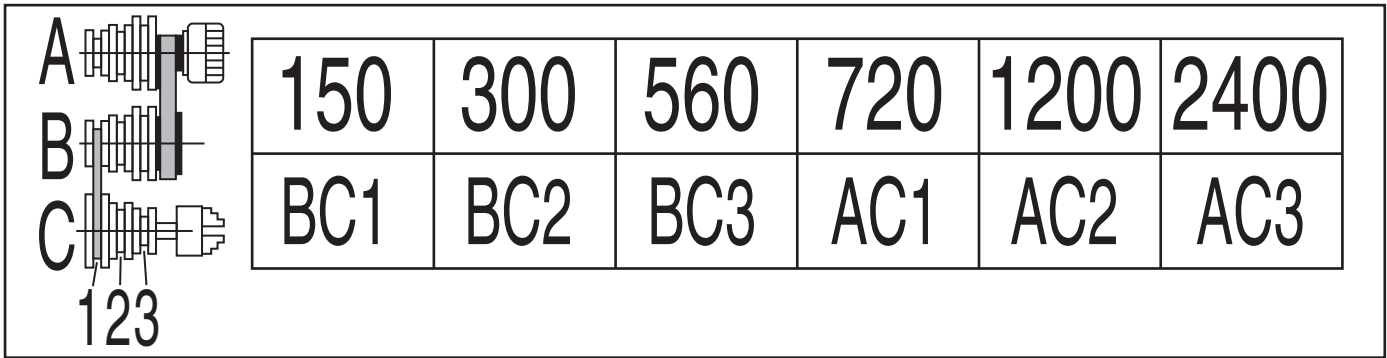

Figure 48. Model G9772Z spindle speed V-belt configuration chart.

WARNING
 The V-belt, change gears, and pulleys represent a serious entanglement hazard when the lathe is running. Always disconnect the lathe from power before opening the change gear cover.

- Use **Figures 49–50** to identify the "A", "B", and "C" pulleys. Also, note the location of the idler pulley.

Configuring the V-Belt

There are six spindle speeds available by properly positioning the V-belt on the motor, idler, and spindle pulleys.

Tools Needed	Qty
Wrench 17mm.....	1

To configure the V-belt:

- DISCONNECT LATHE FROM POWER!
- Refer to the chart in **Figure 48** above and find the spindle speed on the top row that is closest to your calculated spindle speed.

Note: This chart is also on the front of the headstock. In most cases, the calculated spindle speed will be between the available speeds. Use your best judgement when choosing either a higher or lower spindle speed.

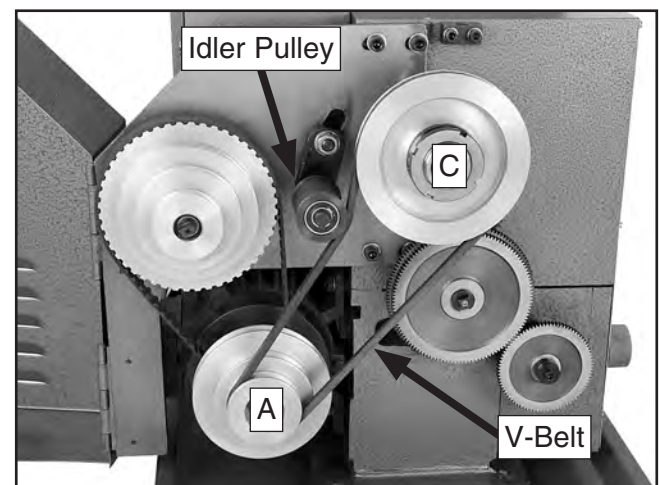

Figure 49. V-belt in the "A-C" configuration.

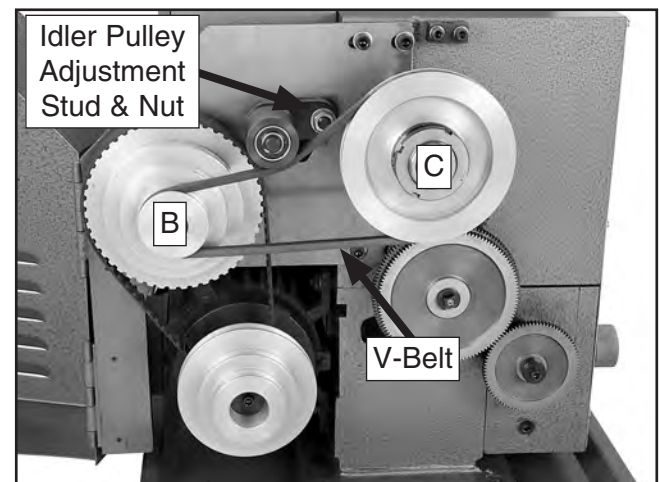

Figure 50. V-belt in the "B-C" configuration.

Note: There is hex nut on either end of the idler pulley adjustment stud that is loosened when adjusting the idler pulley.



4. Configure the V-belt on the pulleys according to the letter and number combination under the selected spindle speed from the chart in **Figure 48**.

Position the idler pulley on top of the V-belt with enough downward pressure to provide tension to the belt, then fully secure it in place. There is correct tension to the V-belt when there is approximately $\frac{1}{2}$ " deflection when moderate pressure is applied to the V-belt half-way between the pulleys.

Note: *The pulley slots are numbered 1–3 with number 1 being the outside slot.*

— For "A–C" configurations (see **Figure 49**), position the longer V-belt (32" in circumference) in the correct "C" pulley slot, then roll it onto the "A" pulley.

— For "B–C" configurations (see **Figure 50**), place the shorter V-belt (29" in circumference) in the correct "C" pulley slot, then roll it onto the "B" pulley.

Power Feed

"Power Feed" on a lathe simply means using the machine-driven components to feed the tool into the workpiece rather than feeding it manually with handwheels.

The speed at which the carriage travels is set with the feed rate dials (see **Feed Rate** on **Page 42** for detailed instructions), but it also depends on spindle speed.

NOTICE

Feed rate is based on the spindle speed. High feed rates result in a rapidly moving carriage. Pay close attention to the feed rate you have chosen and keep your hand poised over the power feed lever. Failure to fully understand this could cause the carriage to crash into the spindle or tailstock resulting in severe damage to the lathe.

When the proper feed rate has been selected for the operation, simply move the power feed lever up to engage the carriage with the power feed (see **Figure 51**). Move the lever down to disengage the power feed.

When the spindle is rotating counterclockwise (towards the operator), the carriage will move toward the spindle when engaged with the power feed. Conversely, when the spindle is rotating clockwise (away from the operator), the carriage will move toward the tailstock.

Note: *If the spindle is not turning, you may have to manually jog the carriage to engage the apron gearing with the leadscrew.*

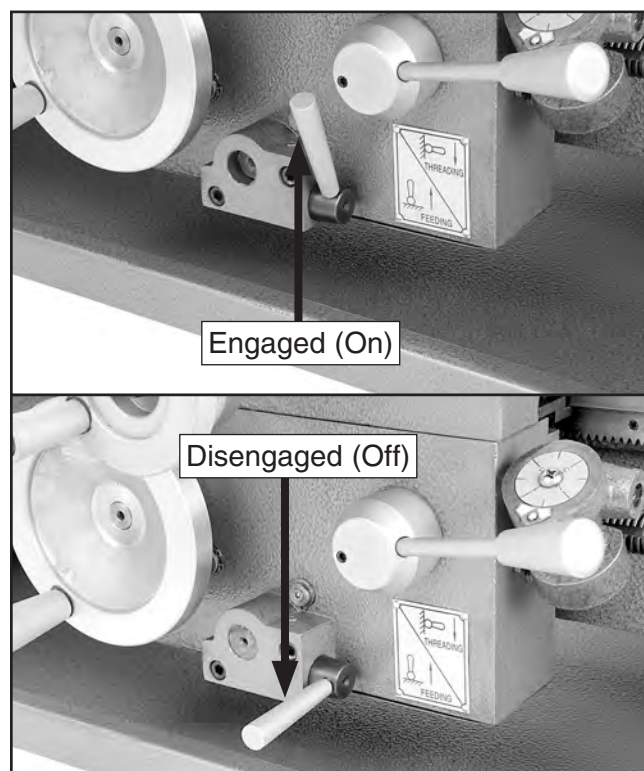

Figure 51. Power feed lever engaged and disengaged.

NOTICE

NEVER attempt to engage the carriage power feed (lever up) and the half-nut (lever down) at the same time. Always disengage the half-nut (lever up) before moving the power feed lever up. Otherwise, severe damage to the lathe could occur.



Feed Rate

Feed rate is the speed the tool travels during the operation and is expressed in inches of carriage travel per revolution of the spindle (IPR), and is set by configuring the change gears and feed rate dials.

The correct feed rate is determined by the workpiece material, the type of tooling used, and the desired finish. The table in **Figure 52** shows the recommended feed rate for turning most metals.

Recommended Feed Rates		
Work Material	Tool Feed Rate (IPR)	
	Rough Cuts	Finish Cuts
Magnesium	0.015–0.025	0.005–0.010
Aluminum	0.015–0.025	0.005–0.010
Brass & Bronze	0.015–0.025	0.003–0.010
Copper	0.010–0.020	0.004–0.008
Cast Iron (Soft)	0.015–0.025	0.005–0.010
Cast Iron (Hard)	0.010–0.020	0.003–0.010
Mild Steel	0.010–0.020	0.003–0.010
Cast Steel	0.010–0.020	0.003–0.010
Alloy Steels (Hard)	0.010–0.020	0.003–0.010
Tool Steel	0.010–0.020	0.003–0.010
Stainless Steel	0.010–0.020	0.003–0.010
Titanium	0.010–0.020	0.003–0.010
Hi Manganese Steel	0.010–0.020	0.003–0.010

Note: These values are a guideline only. Refer to the *MACHINERY'S HANDBOOK* for more detailed information.

Figure 52. Recommended feed rate table.

	a	b	lever	C	A	B
		24	84	II	0.0022	0.0045
	28	70	II	0.0030	0.0060	0.0120
	28	77	I	0.0033	0.0067	0.0135
	35	70	II	0.0038	0.0077	0.0150

Figure 54. Feed rate chart for power feed movement of the carriage.



Use **Figure 53** to identify the change gears and their positions.

Note: This lathe is shipped with the 24 tooth gear installed in the "a" position, and the 84 tooth gear in the "b" position.

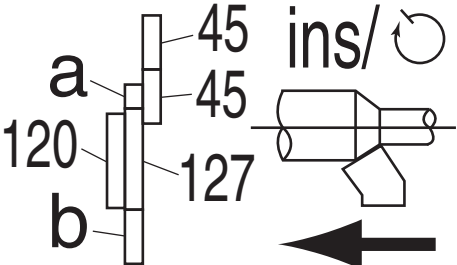
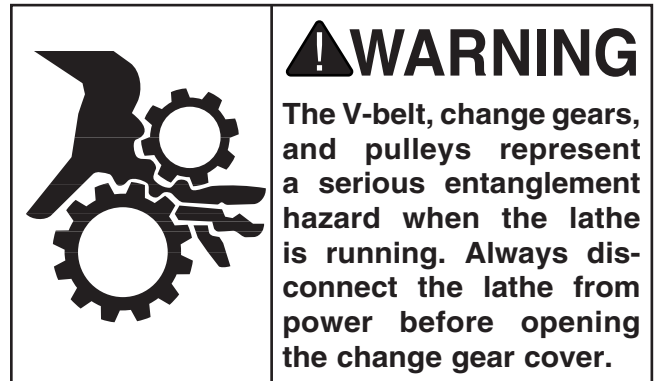
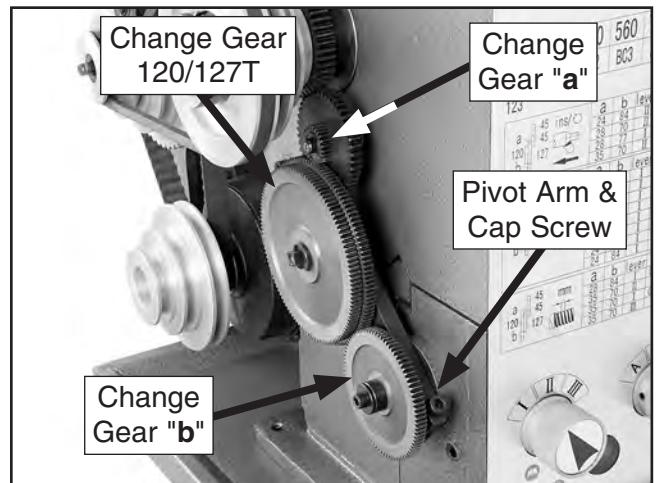

Figure 53. Change gears.



Tools Needed	Qty
Hex Wrench 5mm.....	1
Hex Wrench 6mm.....	1
Wrench 10mm	1
Wrench 14mm	1
Retaining Clip Wrench.....	1
NLGI #2 Grease	As Needed

Configuring Change Gears

1. DISCONNECT LATHE FROM POWER!
2. Examine the chart in **Figure 54** or **Figure 57** to determine the change gear configuration for the selected feed rate.

Note: *The feed rates are given in inches of carriage travel per revolution of the spindle (IPR).*

3. Open the change gear cover, then arrange the change gears as needed. Leave approximately 0.002"–0.003" (0.05–0.08mm) backlash between the gears.

Note: *Before you install the gears, thoroughly clean them with a stiff brush and mild solvent, then apply a light coat of NLGI #2 grease to the teeth.*

Change Gear "a"

- a. Loosen the cap screw securing the pivot arm, then lower it to disengage the 120/127T gear from change gear "a" (see **Figure 55**).

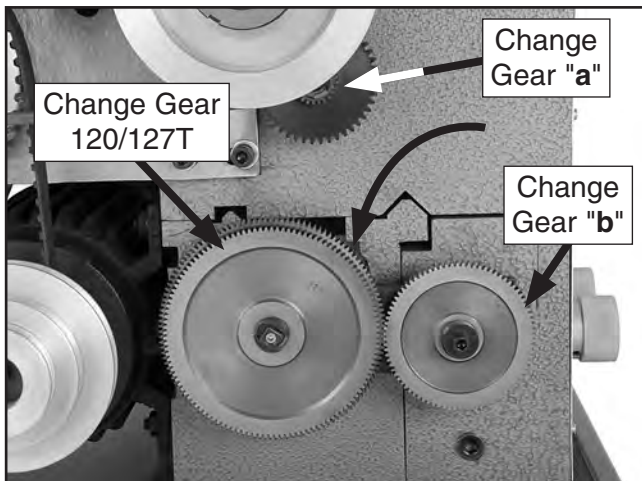

Figure 55. Change gear pivot arm in lowered position.

- b. Remove the E-clip that secures change gear "a", replace the gear with correct one, then replace the E-clip.
- c. Raise the pivot arm so that the 120/127T gear properly meshes with change gear "a", then re-tighten the cap screw to secure it in place.

Change Gear "b"

- a. Lower the pivot arm as described above.
- b. Loosen the square nut on the 120/127T gear and slide it along the pivot arm and away from change gear "b".
- c. Loosen and remove the cap screw securing change gear "b", then remove the flat washer, bushing, and the gear.
- d. Install the correct change gear "b", the bushing, flat washer, and cap screw.

Note: *If change gear "b" must mesh with the 120T gear when cutting metric threads, mount the bushing between the gear and the headstock to properly align the gear.*

- e. Slide the 120/127T gear over to properly mesh with change gear "b", then re-tighten the square nut.
- f. Raise the pivot arm and secure it in place as described above.

4. Rotate the spindle by hand and make sure all change gears are properly meshed and rotating.
 - If the change gears are not properly meshed or rotating freely, repeat this procedure until they are.
5. Close and secure the change gear cover.

Setting the Feed Rate Dials

1. Make sure the spindle motor is **OFF** and the spindle has come to a complete stop.
2. Examine the chart in **Figure 54** or **Figure 57**, then correctly set feed rate dials for your selected feed rate.



NOTICE

NEVER move the feed rate dials while the lathe is running, and **NEVER** force the dials when shifting. If the dial will not engage, rotate the spindle by hand while keeping light pressure on the dial. As the spindle rotates, the feed rate gears will align and the dial will slip into position.

Example of Setting Feed Rate

You will rough cut the length of an aluminum workpiece, reducing the diameter.

Step 1:

Examine the recommended feed rate table (Figure 52 on Page 42) to find the feed rate should be 0.015–0.025 IPR.

Step 2:

Select the nearest feed rate from the feed rate chart (Figure 54 on Page 42) for the lathe. In this case, it will be 0.0150 IPR.

Step 3:

Install the 35T change gear in position "a" and the 70T change gear in position "b".

Step 4:

Turn the left feed rate dial to "II" and the right dial to "B" (see Figure 56).

Note: It may be necessary to jog the spindle by hand to mesh the feed rate gearing and complete the setting of the dials.



Figure 56. Feed rate dials.

	a	b	lever	B	A	C
	35	70	I	8	16	32
	28	63	I	9	18	36
	28	70	I	10	20	40
	28	77	I	11	22	44
	24	69	I	11½	23	46
	28	84	I	12	24	48
	24	78	I	13	26	52
24	84	I	14	28	56	
	a	b	lever	C	A	B
	28	84	I	0.50	1.00	2.00
	35	70	II		1.25	2.50
	35	70	I	0.75	1.50	3.00
35	70	III		1.75	3.50	

Figure 57. Feed rate chart for threading.



Threading Controls

The purpose of this subsection is to orient you with the controls used when threading and how to use the threading dial on this machine.

Power Feed Lever

The power feed lever must be in the disengaged position (down and horizontal) for threading operations or the half-nut will not engage with the leadscrew (see **Figure 58**).

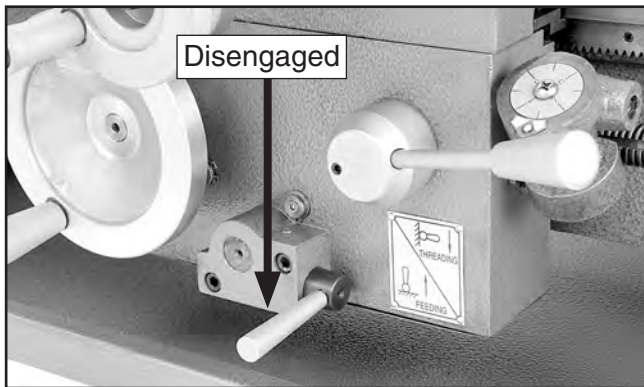

Figure 58. Power feed lever disengaged.

Half-Nut Lever

The half-nut lever engages the carriage with the leadscrew which moves the tool along the workpiece (see **Figure 59**).

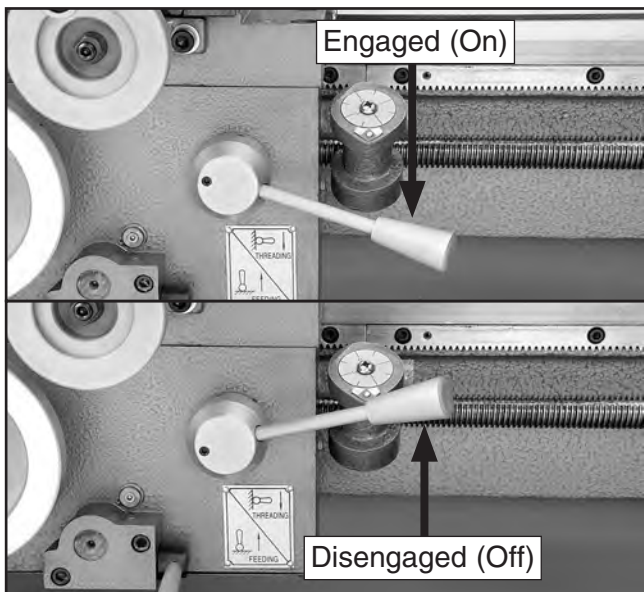

Figure 59. Half-nut lever engaged/disengaged.

Thread Dial & Chart

The numbers on the thread dial are used with the thread dial chart (**Figure 61** on **Page 46**) to show when to engage/disengage the half-nut during inch threading operations.

The thread dial must be engaged with the leadscrew to operate. To engage the thread dial, loosen the mounting cap screw, pivot the thread dial gear onto the leadscrew so the gear teeth mesh with the leadscrew, then re-tighten the cap screw (see **Figure 60**).

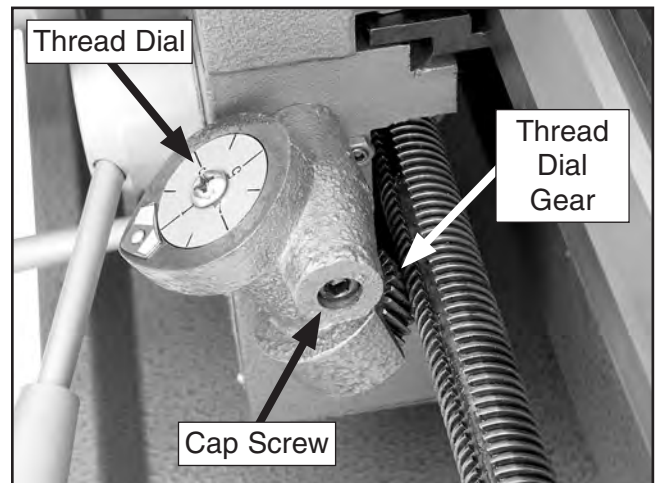

Figure 60. Thread dial.

NOTICE

NEVER attempt to engage the carriage power feed (lever up) and the half-nut (lever down) at the same time, and **NEVER** force these levers. Always disengage the power feed (lever down) before engaging the half-nut. Otherwise, severe damage to the lathe could occur.



To use the thread chart, find the thread pitch per inch (TPI) on the thread dial chart (see **Figure 61**) that you want to cut and reference the "Dial" number next to it. The dial number(s) indicate when to engage the half-nut when cutting that TPI.

 THREAD DIAL	
T.P.I.	DIAL
8 10	1 – 8
12 14	
15 18	
20 22	
24 26	
28 30	
36 38	
40 44	
46 48	
52 56	
9 11	1, 3 5, 7
13 19	
23	
9 ¹ / ₂ -11 ¹ / ₂	2, 6

Figure 61. Thread dial chart.

For example, to cut a TPI of 11, engage the half-nut when the thread dial pointer is on the 1, 3, 5, or 7. To cut a TPI of 24, engage the half-nut on any number between 1 and 8.

To maintain accuracy and consistency, engage the half-nut on the same thread dial number on each pass. Failure to start on the same number each time may lead to cutting off the thread made in the previous pass.

Note: *The thread dial is not used when cutting metric threads. Leave the half-nut engaged until the threads are complete.*

NOTICE

DO NOT engage the half-nut when the spindle speed is over 300 RPM. Ignoring this instruction could result in damage to the leadscrew or carriage components.



SECTION 5: ACCESSORIES

!WARNING

Installing unapproved accessories may cause machine to malfunction, resulting in serious personal injury or machine damage. To reduce this risk, only install accessories recommended for this machine by Grizzly.

NOTICE

Refer to our website or latest catalog for additional recommended accessories.

G9849—Magnetic Base/Dial Indicator Combo
Precision measurements and setups have never been so easy. Magnetic base engages with just the turn of a switch and allows pinpoint adjustment. The dial indicator features 0–1" travel and has a resolution of 0.001". This fine set includes a molded case for protection and convenience.



Figure 62. G9849 Magnetic Base/Dial Indicator Combo.

T27914—Moly-D Machine and Way Oil, 1 Gal.
This ISO 68 machine and way oil is one of the best we've found for maintaining bed ways, sliding ways, gearboxes, and leadscrews. Why? It is extremely tacky and includes the superior friction-reducing compound Moly-D to maximize component life and minimize wear.



Figure 63. T27914 Moly-D Machine and Way Oil.

T26419—Syn-O-Gen Synthetic Grease
Formulated with 100% pure synthesized hydrocarbon basestocks that are compounded with special thickeners and additives to make Syn-O-Gen non-melt, tacky, and water resistant. Extremely low pour point, extremely high temperature oxidation, and thermal stability produce a grease that is unmatched in performance.



Figure 64. T26419 Syn-O-Gen Synthetic Grease.

order online at www.grizzly.com or call 1-800-523-4777



G1070—MT3 Live Center Set

A super blend of quality and convenience, this live center set offers seven interchangeable tips. High-quality needle bearings prolong tool life and special tool steel body and tips are precision ground. Supplied in wooden box.



Figure 65. G1070 Live Center Set.

H7540—Metalworking Kit No. 1

Get started with the practical lathe kit that includes the following hand essentials:

- Double-ended boring bar with holder and two 1/4" HSS tool bits
- Two round head fly cutters
- Six-head knurling tool
- Double-ended knurling tool
- Straight turning tool holder with 5/16" HSS tool bit
- Cut-off tool holder with three HSS blades
- Hex wrenches
- Protective wooden case



Figure 66. Model H7540 Metalworking Kit No. 1.

G1075—52-PC. Clamping Kit, 1/2" T-Nut

Our clamping kits are among the best in the world! All the blocks, bolts, nuts, and hold-downs are case hardened. This clamping kit includes: 24 studs, 6 step block pairs, 6 T-nuts, 5 flange nuts, 4 coupling nuts, and 6 end hold-downs. The rack can be bolted to the wall or side of the machine for easy access.

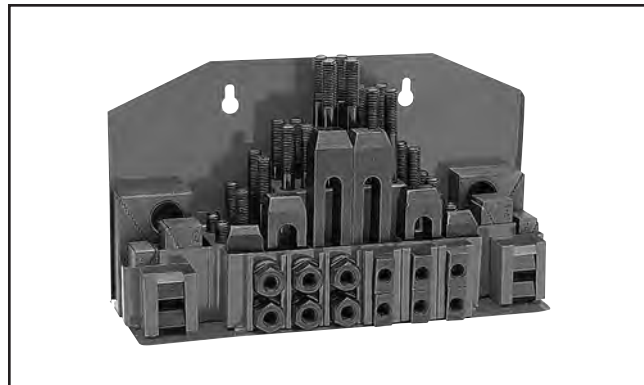

Figure 67. G1075 52-PC. Clamping Kit.

G9257—8" Dial Caliper

These traditional dial calipers are accurate to 0.001" and can measure outside surfaces, inside surfaces, and heights/depths. Features stainless steel, shock resistant construction and a dust proof display. An absolute treat for the perfectionist!



Figure 68. Model G9257 8" Dial Calipers.

order online at www.grizzly.com or call 1-800-523-4777



H2972—Cut Off Holder with Blade

H4268— $\frac{3}{32}$ " x $\frac{5}{8}$ " x 5" Replacement Blade

Small enough to fit most 4-way turret tool posts, but rugged enough to handle the job, this cut-off tool holder is a must. Comes with a wrench and cut-off tool bit. Uses $\frac{3}{32}$ " x $\frac{5}{8}$ " x 5" tool bits. Shank measures $\frac{1}{2}$ " x $\frac{1}{4}$ " x 3".



Figure 69. H2972 Cut Off Holder with Blade.

H2996—Double Ended Boring Bar

This is a well made boring bar and holder. The boring bar holds the tool bit at 90° at one end and 45° at the other. Comes with a wrench and tool bit. Bar size is $\frac{3}{8}$ " x 4 $\frac{1}{2}$ ", holder is 2 $\frac{1}{4}$ " x $\frac{1}{2}$ ", uses $\frac{1}{8}$ " tool bits.

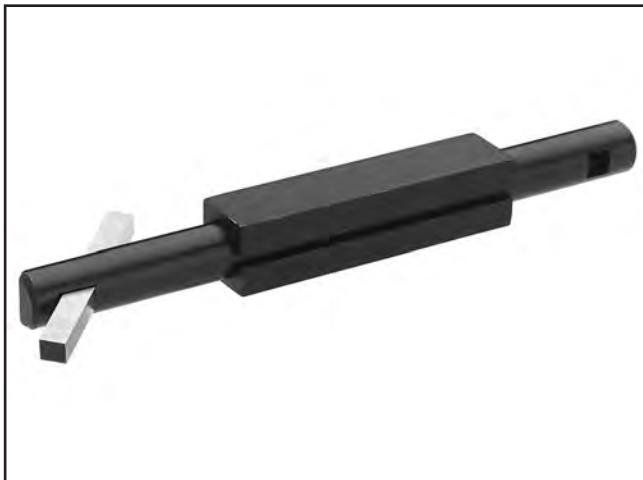

Figure 70. H2996 Double Ended Boring Bar.

H5936—2 Pc. Knurling Tool Set

This 2 piece set includes a $\frac{1}{2}$ " x 4" Single Knurling Tool Holder and a $\frac{1}{2}$ " x 4 $\frac{1}{2}$ " Double Knurling Tool Holder with Pivoting Head. Both have a black oxide finish.



Figure 71. H5936 2 Pc. Knurling Tool Set.

H2987— $\frac{1}{2}$ " Bent Lathe Dog

Just the thing for precision machining between centers! These bent tail Lathe Dogs are made of durable cast iron and feature square head bolts.

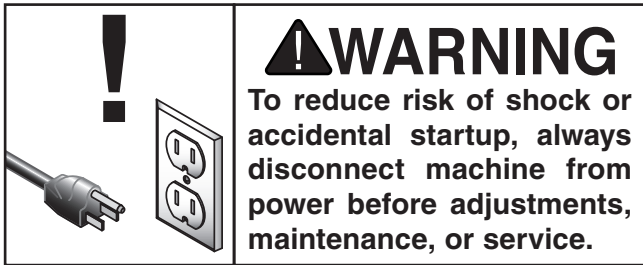

Figure 72. H2987-91 Lathe Dogs.

order online at www.grizzly.com or call 1-800-523-4777



SECTION 6: MAINTENANCE



Schedule

For optimum performance from this machine, this maintenance schedule must be strictly followed.

Ongoing

To minimize your risk of injury and maintain proper machine operation, shut down the machine immediately if you ever observe any of the items below, and fix the problem before continuing operations:

- Loose mounting bolts.
- Guards or covers removed.
- Worn or damaged wires.
- Any other unsafe condition.

Daily Maintenance

- Lubricate lathe (**Pages 51–54**).
- Disengage the half nut on the carriage (to prevent crashes upon startup).
- Ensure carriage lock bolt is loose.

Monthly Check

- V-belt tension, damage, or wear.

After First Three Months and Annually:

- Change feed rate gearbox oil (**Page 52**).

Cleaning & Protecting

Because of its importance, we recommend that the cleaning routine be planned into the workflow schedule.

Typically, the easiest way to clean swarf from the machine is to use a wet/dry shop vacuum that is dedicated for this purpose. The small chips left over after vacuuming can be wiped up with a slightly oiled rag. Avoid using compressed air to blow off chips, as this may drive them deeper into the moving surfaces or cause sharp chips to fly into your face or hands.

All unpainted and machined surfaces should be wiped down daily to keep them rust free and in top condition. This includes any surface that is vulnerable to rust if left unprotected (especially parts that are exposed to water soluble cutting fluid). Use a quality rust protectorate such as SLIPIT® or Boeshield® to prevent corrosion.

Recommended Metal Protectants

G5562—SLIPIT® 1 Qt. Gel

G5563—SLIPIT® 12 Oz. Spray

G2870—Boeshield® T-9 4 Oz. Spray

G2871—Boeshield® T-9 12 Oz. Spray

H3788—G96® Gun Treatment 12 Oz. Spray

H3789—G96® Gun Treatment 4.5 Oz. Spray



Figure 73. Recommended products for protecting unpainted cast iron/steel parts on machinery.



Lubrication

Your lathe has numerous moving metal-to-metal contacts that require proper lubrication to help ensure efficient and long-lasting operation.

Other than the lubrication points covered in this section, all other bearings are internally lubricated and sealed at the factory. Simply leave them alone unless they need to be replaced.

Before adding lubricant, clean away any debris and grime from the lubrication point to avoid contaminating the lubricant and increasing wear of the moving parts.

DISCONNECT THE LATHE FROM POWER BEFORE PERFORMING LUBRICATION!

Ball Oilers

Lubricant	Frequency	Qty
ISO 68 or Equivalent Lubricant	Every 8 Hours of Operation	1 squirt from Oil Can

Wipe clean and lubricate the ball oilers shown in **Figures 74–78**. To insert the oil, depress the ball with the tip of an oil can and squirt once.

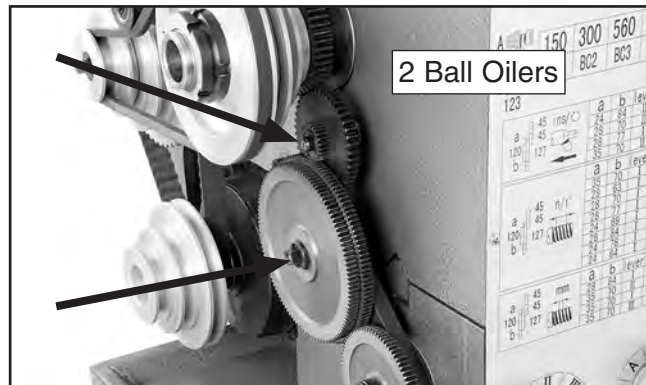

Figure 74. Change gear ball oilers.

NOTICE

Follow reasonable lubrication practices as outlined in this manual for your lathe. Failure to do so could lead to premature failure of your lathe and will void the warranty.



Figure 75. Spindle bearing ball oilers.

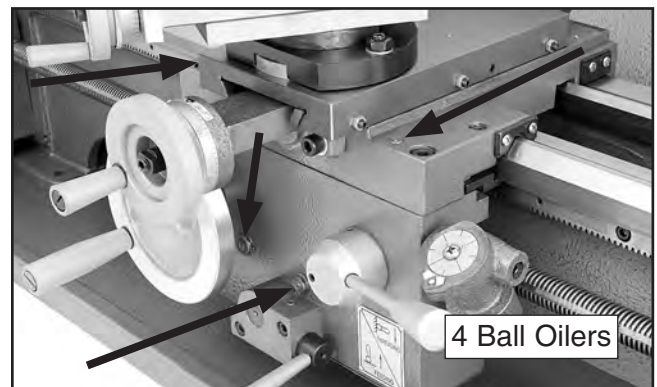

Figure 76. Apron ball oilers.

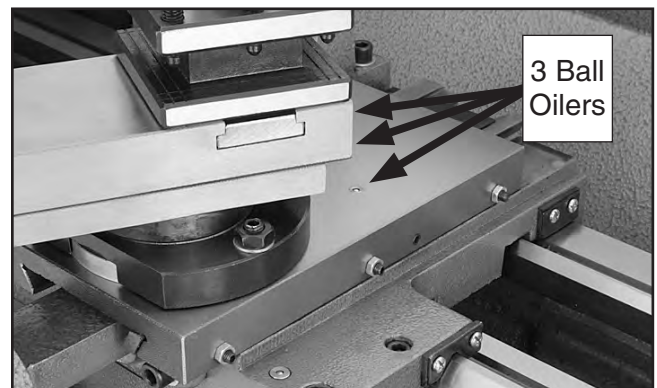

Figure 77. Cross slide ball oilers (one in view).



Figure 78. Tailstock quill and leadscrew ball oilers.



Feed Rate Gearbox Oil Reservoir

Lubricant	Frequency	Qty
ISO 68 or Equivalent Lubricant	Check/ Fill Every 8 Hours of Operation	Half-Way Mark in Sight Glass

The feed rate gearbox oil reservoir must be checked and oil added, if necessary, on a daily basis.

Tools Needed	Qty
Hex Wrench 8mm.....	1

To check and add oil to the reservoir:

1. Check the oil reservoir sight glass shown in **Figure 79**. If the oil level is below the half-way mark, continue with the following steps to add oil.

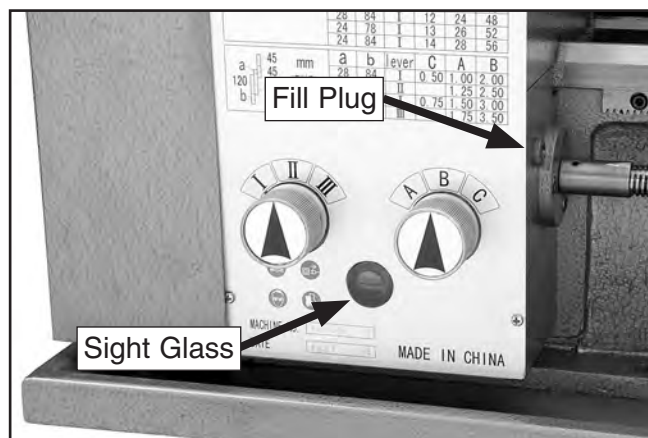

Figure 79. Feed rate gearbox oil reservoir sight glass and fill plug.

2. Wipe clean the area around the fill plug to prevent debris from falling into the reservoir when adding oil.
3. Remove the fill plug.
4. Slowly add oil until the level is centered in the sight glass.
5. Replace the fill plug.

NOTICE

The feed rate gearbox oil must be changed after the first three months of operation, then annually after that.

Tools Needed	Qty
Hex Wrench 8mm.....	1
Drain Pan (at least 1 Gallon Capacity).....	1

To change the oil in the reservoir:

1. DISCONNECT LATHE FROM POWER!
2. Open the change gear cover on the left of the headstock.
3. Remove the reservoir fill plug (see **Figure 79**).

Note: If you are experiencing difficulty removing the fill plug, do not remove the drain plug to drain the reservoir until you can successfully remove the fill plug. This way you can still operate the lathe until the issue is resolved.

4. Hold the drain pan under the reservoir drain plug, then remove the drain plug shown in **Figure 80**, and allow the oil to completely drain into the pan.

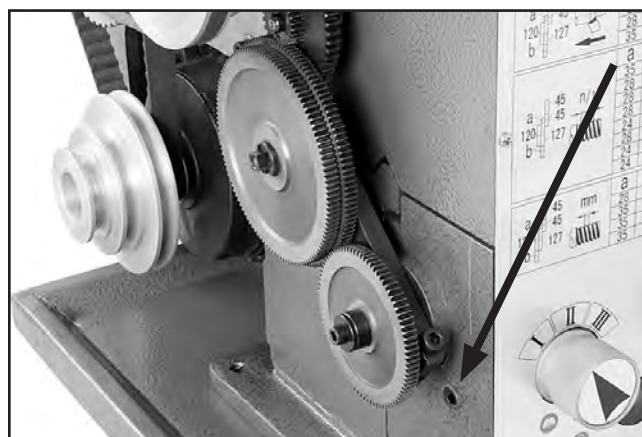

Figure 80. Feed rate gearbox oil reservoir drain plug.



5. While holding the pan under the drain hole, pour approximately ½ quart of clean oil into the reservoir to flush out any sediment from along the bottom.
6. Re-install the drain plug and add oil to the reservoir until the oil level is centered in the sight glass.
7. Re-install the fill plug and close the change gear cover.

Longitudinal Leadscrew & Carriage Rack

Lubricant	Frequency	Qty
ISO 68 or Equivalent Lubricant	Every 8 Hours of Operation	Thin Coat

Maintain a thin coat of oil on the longitudinal leadscrew threads and the carriage rack (see **Figure 81**) at all times. Use a stiff brush and mild solvent to remove any debris or grime before using a clean shop rag to wipe on the oil.

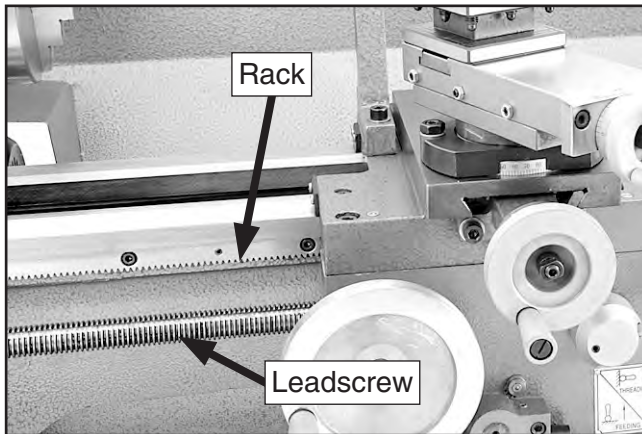

Figure 81. Longitudinal leadscrew and carriage rack.

Compound Slide

Lubricant	Frequency	Qty
Way Oil	Every 8 Hours of Operation	Thin Coat

Maintain a thin coat of way oil on the slide surface of the compound slide. Use the handwheel to move the compound slide all the way toward you (see **Figure 82**), then wipe clean the bottom slide with a rag and mild solvent. Apply the lubricant and move the compound slide back and forth to distribute the oil.

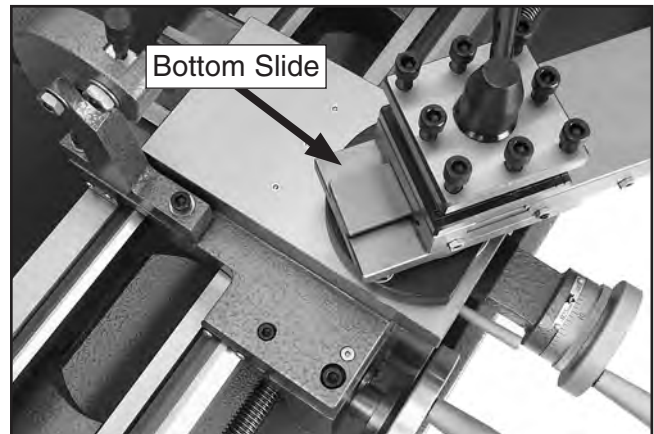

Figure 82. Compound bottom slide.



Feed Lever Plunger

Lubricant	Frequency	Qty
ISO 68 or Equivalent Lubricant	Every 8 Hours of Operation	1 squirt from Oil Can

Wipe clean the feed lever plunger shown in **Figure 83**, then apply the lubricant. With the machine **OFF**, move the feed lever up and down to distribute the oil.

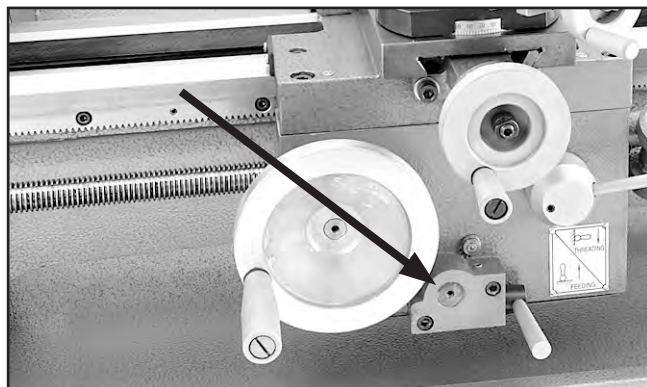

Figure 83. Feed lever plunger.

Bedways

Lubricant	Frequency	Qty
Way Oil	Every 8 Hours of Operation	Thin Coat

To keep the bedways rust-free and components sliding smoothly along the surface, maintain a thin coat of way oil on the bedway. Move the steady rest, carriage, and tailstock to access the entire length of the bedway.

We recommend using Model H8257 Primrose Armor Plate with Moly-D Machine and Way Oil (see **ACCESSORIES** on **Page 47**).

Change Gears

Lubricant	Frequency	Qty
NLGI #2 Grease	Check/Add Every 8 Hours of Operation	Thin Coat

Maintain a thin coat of grease on the change gear teeth. Move the V-belt away from the gears, then use a stiff brush and a mild solvent to clean debris and grime from the gears. Use a clean, dry rag to wipe off the solvent. Brush on a thin coat of lubricant to the teeth and rotate the spindle by hand to distribute the grease.

NOTICE

Follow reasonable lubrication practices as outlined in this manual for your lathe. Failure to do so could lead to premature failure of your lathe and will void the warranty.



SECTION 7: SERVICE

Review the troubleshooting procedures in this section if a problem develops with your machine. If you need replacement parts or additional help with a procedure, call our Technical Support. **Note:** *Please gather the serial number and manufacture date of your machine before calling.*

Troubleshooting

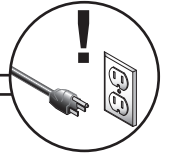

Motor & Electrical

Symptom	Possible Cause	Possible Solution
Machine does not start or a breaker trips.	<ol style="list-style-type: none"> 1. Plug or receptacle is at fault or wired incorrectly. 2. Start capacitor is at fault. 3. Wall fuse or circuit breaker is blown or tripped. 4. Motor connection is wired incorrectly. 5. Power supply is at fault, or is switched OFF. 6. Motor ON/OFF button is at fault. 7. Centrifugal switch is at fault. 8. Spindle switch is at fault. 9. Cable or wiring is open or has high resistance. 10. Motor is at fault. 	<ol style="list-style-type: none"> 1. Test power plug and receptacle for good contact and correct wiring. 2. Test capacitor and replace if necessary. 3. Make sure circuit breaker/fuse is sized correctly for machine load; replace faulty breaker. 4. Correct motor wiring (Page 65). 5. Make sure all hot lines and grounds are operational and have correct voltage. 6. Replace faulty motor ON/OFF button. 7. Adjust/replace. 8. Test; replace if necessary. 9. Troubleshoot wires for internal/external breaks; check for disconnected or corroded connections; repair or replace faulty wiring or connections. 10. Test/repair/replace.
Machine has vibration or noisy operation.	<ol style="list-style-type: none"> 1. Motor or component is loose. 2. V-belt worn, damaged, or loose. 3. Motor fan is rubbing on fan cover. 4. Pulley set screws or keys are missing or loose. 5. Machine is incorrectly mounted. 6. Cutting tool is chattering. 7. Workpiece or chuck is at fault. 8. Spindle bearings are at fault. 9. Motor bearings are at fault. 10. Gears are at fault. 	<ol style="list-style-type: none"> 1. Inspect/replace stripped or damaged fasteners; re-tighten with thread locking fluid. 2. Replace/re-tension V-belt (Page 40). 3. Repair/replace dented fan cover or fan. 4. Inspect set screws/keys; replace/tighten if necessary. 5. Re-tighten/replace machine mounting hardware as necessary; use shims where required. 6. Re-sharpen/replace cutting tool; index tool to workpiece; use correct feed rate and spindle speed. 7. Re-center and properly secure workpiece in chuck or faceplate; replace defective chuck/faceplate. 8. Tighten/replace spindle bearings (Page 61). 9. Rotate motor shaft to check for noisy or burnt bearing; repair/replace as necessary. 10. Replace bad gears/bearings.



Motor & Electrical (continued)

Symptom	Possible Cause	Possible Solution
Machine stalls or is overloaded.	<ol style="list-style-type: none"> 1. Wrong workpiece material. 2. Workpiece alignment is at fault. 3. Incorrect spindle speed for task. 4. Low power supply. 5. Run capacitor is at fault. 6. V-belt is slipping. 7. Plug or receptacle is at fault. 8. Motor connection is wired incorrectly. 9. Motor bearings are at fault. 10. Machine is undersized for the task. 11. Motor has overheated. 12. Spindle switch is at fault. 13. Motor is at fault. 14. Centrifugal switch is at fault. 	<ol style="list-style-type: none"> 1. Only process metal that has the correct properties for your type of machining. 2. Re-center and properly secure workpiece in chuck or faceplate. 3. Correctly set V-belt for your operation (Page 39). 4. Make sure all hot lines and grounds are operational and have correct voltage. 5. Test and replace if necessary. 6. Check V-belt and re-tension; replace if necessary (Page 40). 7. Test power plug and receptacle for good contact and correct wiring. 8. Correct motor wiring (Page 65). 9. Rotate motor shaft to check for noisy or burnt bearing; repair/replace as necessary. 10. Use sharp cutting tools at the correct angle, reduce feed rate or depth of cut, and use coolant if possible. 11. Clear obstacles away from the motor fan cover, let motor cool, and reduce workload on machine. 12. Test; replace if necessary. 13. Test/repair/replace. 14. Adjust/replace.



Operations

Symptom	Possible Cause	Possible Solution
Bad surface finish.	<ol style="list-style-type: none"> 1. Incorrect spindle speed or feed rate. 2. Dull tool or poor tool selection. 3. Too much play in gibs. 4. Tool too high. 	<ol style="list-style-type: none"> 1. Adjust for proper spindle speed and feed rate (Pages 39–42). 2. Use sharp tools; use correct tool for the operation. 3. Adjust gibs (Page 59). 4. Lower tool position.
Cannot remove tapered tool from tailstock quill.	<ol style="list-style-type: none"> 1. Quill not retracted all the way back into the tailstock. 2. Debris/oil not removed from tapered mating surfaces before inserting into quill. 	<ol style="list-style-type: none"> 1. Rotate the quill handwheel until the tapered tool is forced out of quill. 2. Always make sure that tapered mating surfaces are clean before inserting.
Gear(s) will not line up and mesh.	<ol style="list-style-type: none"> 1. Gear(s) not aligned in headstock. 	<ol style="list-style-type: none"> 1. Rotate spindle by hand until gear(s) falls into place.
Cutting tool or machine components vibrate excessively during cutting.	<ol style="list-style-type: none"> 1. Tool holder not tight enough. 2. Cutting tool too far out from holder; lack of support. 3. Too much play in gibs. 4. Cutting tool is dull. 5. Incorrect spindle speed or feed rate. 	<ol style="list-style-type: none"> 1. Check for debris, clean, and re-tighten. 2. Re-install cutting tool with no more than 1/3 of total length is sticking out of tool holder. 3. Adjust gibs (Page 59). 4. Sharpen/replace. 5. Adjust for proper spindle speed and feed rate (Pages 39–42).
Cross/compound slide or carriage feed has sloppy operation.	<ol style="list-style-type: none"> 1. Too much play in gibs. 2. Handwheel(s) loose. 3. Too much leadscrew backlash (cross slide only). 4. Leadscrew mechanism worn or out of adjustment. 	<ol style="list-style-type: none"> 1. Adjust gibs (Page 59). 2. Tighten handwheel fasteners. 3. Adjust leadscrew backlash (Page 58). 4. Tighten any loose fasteners on leadscrew mechanisms; check for excessive wear/replace if necessary.
Cross/compound slide or carriage feed hard to move.	<ol style="list-style-type: none"> 1. Gibs are loaded up with chips/grime. 2. Gibs are too tight. 3. Leadscrew backlash setting too tight (cross slide only). 4. Bedways are dirty/dry. 5. Gearing is at fault. 	<ol style="list-style-type: none"> 1. Remove gibs, clean ways, lubricate, and properly adjust gibs (Page 59). 2. Adjust gibs (Page 59). 3. Properly adjust cross slide leadscrew backlash (Page 58). 4. Clean and lubricate bedways. 5. Inspect/replace gearing.
Inaccurate turning results from one end of workpiece to the other.	<ol style="list-style-type: none"> 1. Tailstock not properly aligned with headstock. 	<ol style="list-style-type: none"> 1. Properly align tailstock with headstock (Page 31).
Chuck jaws will not move or do not move easily.	<ol style="list-style-type: none"> 1. Chips/debris lodged in jaws. 	<ol style="list-style-type: none"> 1. Remove jaws, clean and lubricate jaws, scroll-gear threads, and chuck, then replace jaws.
Tailstock quill will not feed out of tailstock.	<ol style="list-style-type: none"> 1. Quill lock is tightened down. 	<ol style="list-style-type: none"> 1. Turn quill lock counterclockwise to loosen.



Cross Slide Backlash Adjustment

Backlash is the amount of play in a leadscrew. It is felt when turning a handwheel in one direction, then turning it in the other direction. The distance that the handwheel moves without moving the leadscrew or components is the backlash.

When adjusting backlash, tighten the components enough to remove excessive backlash, but not so much that the components bind the leadscrew, making it hard to turn. Overtightening will cause excessive wear to the sliding block and leadscrew.

Tools Needed	Qty
Hex Wrench 4mm.....	1
Hex Wrench 5mm.....	1
Wrench 14mm	1

To adjust the cross slide backlash:

1. Loosen the hex nuts and remove the set screws and flat washers that secure the compound slide to the cross slide (see **Figures 84–85**).

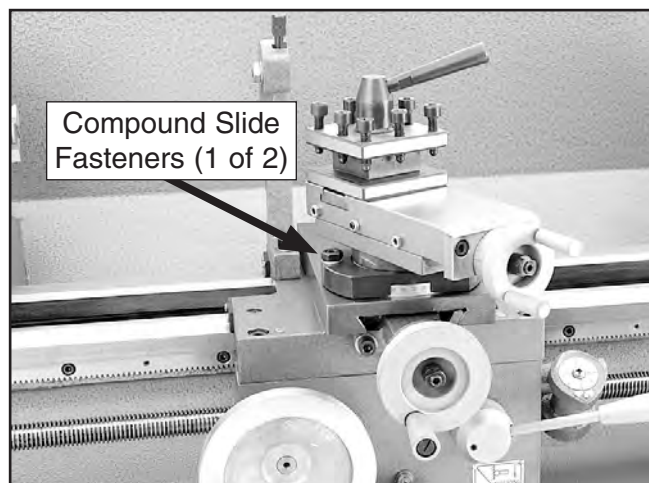

Figure 84. Compound slide fasteners.

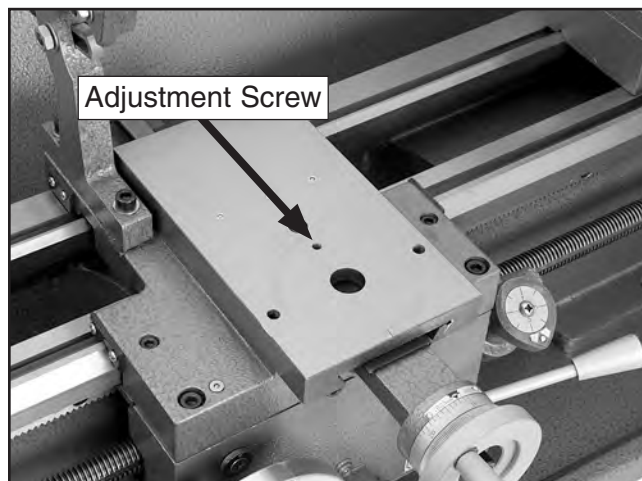

Figure 85. Cross slide backlash adjustment set screw (compound slide removed).

2. Remove the compound slide and place it in a clean, stable location.
3. Adjust the backlash adjustment cap screw shown in **Figure 85** in small increments.

Note: Turn the adjustment screw clockwise to reduce backlash and counterclockwise to increase it.

4. Test after each adjustment by rotating the handwheel back-and-forth until the backlash amount is acceptable.
5. Re-install the compound slide.



Gib Adjustments

The gibs on the Model G9972Z control the accuracy of the cross slide and compound slide movements. These gibs are sliding plates that either increase or decrease pressure on the sliding components around them.

The goal of gib adjustment is to remove unnecessary sloppiness without causing the ways to bind. Tight gibs make the movements more accurate, but harder to perform. Loose gibs make the movements sloppy, but easier to perform.

NOTICE

Excessively loose gibs may cause poor workpiece finishes, and may cause undue wear of the sliding surfaces and ways. Over-tightening the gibs may cause premature wear of these sliding surfaces.

Tools Needed	Qty
Wrench 8mm.....	1
Hex Wrench 2.5mm.....	1

To adjust the cross slide and compound slide gibs:

1. DISCONNECT LATHE FROM POWER!
2. Loosen the three hex nuts on the side of the slide (see **Figures 86–87**).

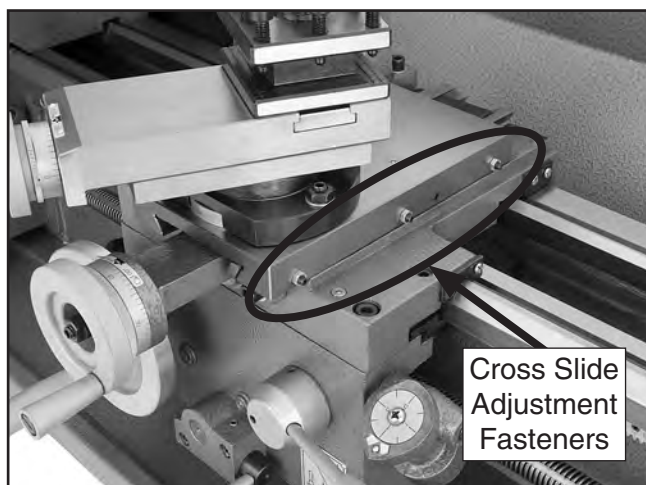

Figure 86. Cross slide gib adjustment hex nuts and set screws.

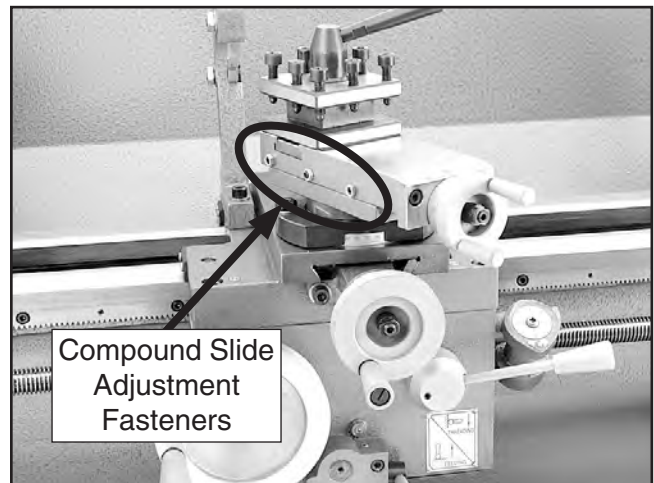

Figure 87. Compound slide gib adjustment hex nuts and set screws.

3. Make adjustments in small and equal increments to the three set screws, then test the movement of the slide by rotating the handwheel.

Note: *Turning the set screws clockwise will tighten the gib, and turning them counter-clockwise will loosen the gib.*

4. When you are satisfied with the gib adjustment, keep the set screws from moving and re-tighten the hex nuts to secure the settings.
5. Re-check the movement of the slide and, if necessary, repeat **Steps 2–4**.



Half-Nut Adjustment

Over time and with normal wear, the half-nut may become excessively loose when it engages the leadscrew. The half-nut gib is a flat bar that exerts pressure against the half-nut mechanism. The goal of the half-nut adjustment is to remove unnecessary looseness as the half-nut engages the leadscrew without binding it so tight that the half-nut will not release and possibly cause damage to the lathe.

Tools Needed	Qty
Wrench 8mm.....	1
Hex Wrench 5mm.....	1
Hex Wrench 2.5mm.....	1

To adjust the half-nut:

1. DISCONNECT LATHE FROM POWER!
2. Move the half-nut lever up to disengage the half-nut from the leadscrew, then remove the thread dial from the apron.
3. Loosen the two adjustment hex nuts, then adjust the set screws in small increments (see **Figure 88**).

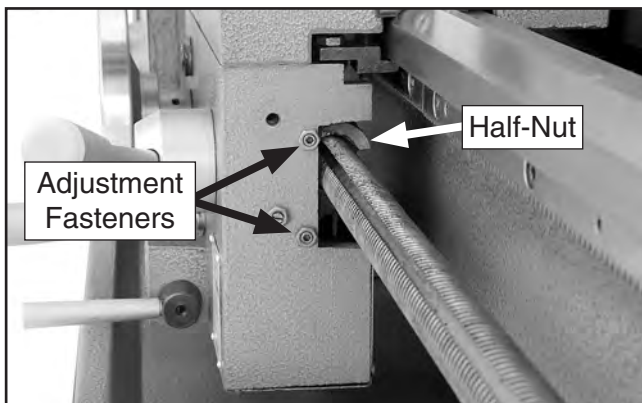

Figure 88. Half-nut gib adjustment hex nuts and set screws (thread dial removed).

5. Engage the half-nut with the leadscrew, then manually rock the carriage back-and-forth while observing the half-nut for looseness.
6. When you are satisfied with the adjustment, keep the set screws from moving while you re-tighten the hex nuts, then re-install the thread dial.

Shear Pin Replacement

The longitudinal leadscrew is secured to the feed rate gearing in the headstock with the use of a soft-metal shear pin (see **Figure 89**). The shear pin is designed to break and disengage power to the leadscrew to help protect more expensive lathe components if you crash your carriage or take too large of a cut and overload the lathe.

Contact Grizzly Customer Service at (570) 546-9663 to order a replacement shear pin (Part # P9972Z0315).

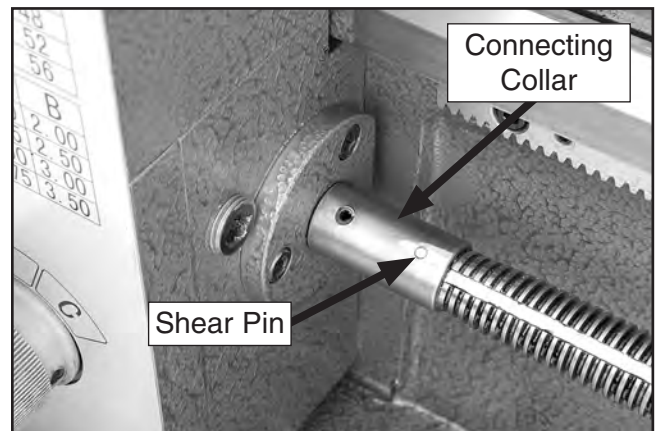

Figure 89. Longitudinal leadscrew shear pin.

Tools Needed	Qty
Hammer.....	1
Punch 2.5mm.....	1

To replace the shear pin:

1. DISCONNECT LATHE FROM POWER!
2. Rotate the leadscrew so the shear pin faces up and down. If the connecting collar rotates independently from the leadscrew, then rotate the collar so the shear pin holes align with those in the leadscrew.
3. Use the punch and hammer to drive out the pieces of the old shear pin.
4. Make sure the holes in the collar and leadscrew are aligned, then tap the new shear pin completely through the holes in the collar and leadscrew.



Ribbed Belt Replacement

The ribbed belt transfers power from the motor to the secondary drive pulley (see **Figure 90**). If the ribbed belt becomes excessively worn or damaged, you will need to replace it.

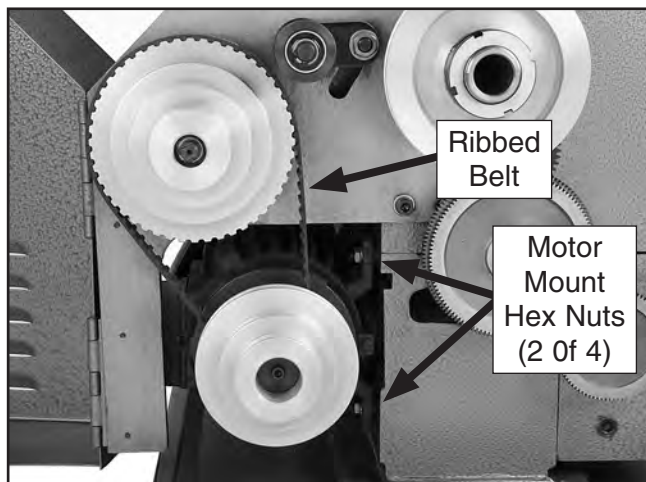

Figure 90. Ribbed belt and motor mount hex nuts.

Tools Needed	Qty
Hex Wrench 5mm (optional)	1
Wrench 14mm	1

To replace the ribbed belt:

1. DISCONNECT LATHE FROM POWER!
2. Open the change gear cover and remove the V-belt.
3. Loosen the four motor mount hex nuts and raise the motor up.

Note: *It may be more convenient to access the motor mount hex nuts if you first remove the rear splash guard.*

4. Roll the old ribbed belt off the pulleys and replace it with a new one, making sure that the belt ribs are seated in the pulley indents.
5. Lower the motor to produce reasonable tension on the ribbed belt, then re-tighten the motor mount hex nuts.
6. Re-install the V-belt and close the cover.

Model G9972Z (Mfd. Since 03/20)

Bearing Preload

This lathe is shipped from the factory with the spindle bearing preload properly adjusted. If the spindle ever develops excessive end-play and the workpiece finish suffers, you can adjust the bearing preload to remove the unnecessary end-play and improve the workpiece finish.

Tools Needed	Qty
Spanner Wrench 2"	1
Large Phillips Screwdriver	1
Dial Indicator with Magnetic Base	1
Heavy Dead Blow Hammer	1
Wooden Block	1

To adjust the spindle bearing preload:

1. Run the lathe for approximately 20 minutes on high speed to bring the lathe to normal operating temperature.
2. DISCONNECT LATHE FROM POWER!
3. Remove the chuck or faceplate from the spindle, then open the change gear cover to expose the outboard end of the spindle (see **Figure 91**).

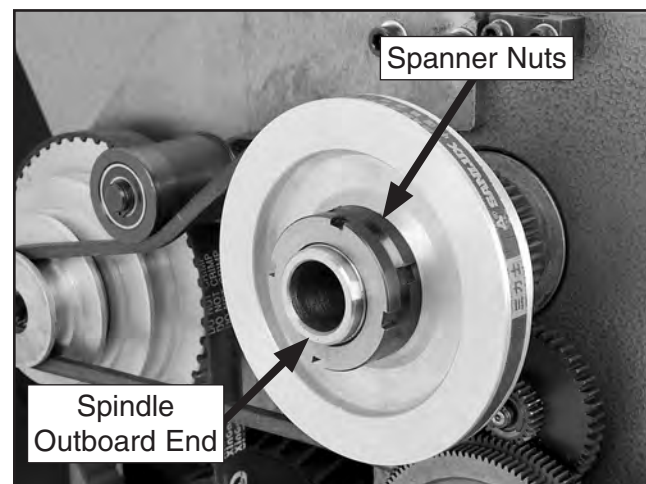

Figure 91. Outboard end of spindle and spanner nuts.



4. Insert the handle of a chuck key or similar tool in a spindle indent to keep the spindle from rotating, then remove the outer spanner nut (see **Figure 91**).
5. Loosen the inner spanner nut one full turn counterclockwise.

Note: You may have to tap on the outboard spindle tube as explained in **Step 6** to help unload the spindle preload and break the spanner nut loose.

6. Place a wooden block over the outboard end of the spindle, and hit it soundly with the heavy dead blow hammer (see **Figure 92**). Your goal is to slide the spindle forward just enough to introduce spindle end-play that you can feel by hand.

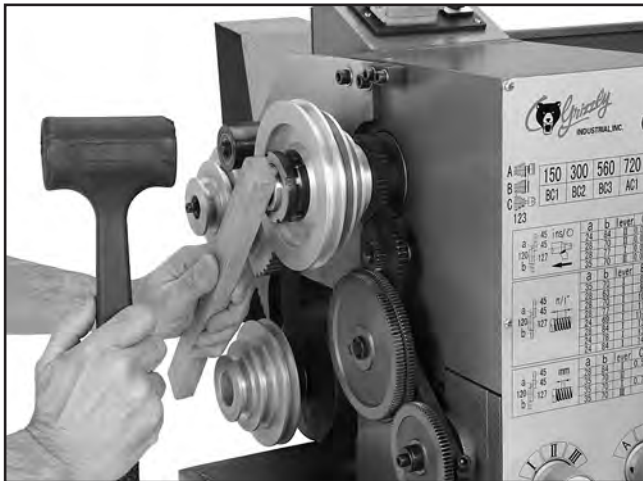

Figure 92. Producing detectable spindle end-play.

7. Place a dial indicator on the cross slide and move the carriage toward the spindle until the contact point of the indicator lightly touches the spindle face and the dial reads exactly zero (see **Figure 93**).



Figure 93. Dial indicator setup.

8. Move the carriage an additional 0.100" toward the headstock.
9. Insert the handle of a chuck key or similar tool in the spindle indents to keep the spindle from rotating, then tighten the inner spanner nut until the indicator dial needle just stops moving and is back to exactly zero.

Note: While tightening the spanner nuts, rock the spindle back and forth slightly to make sure the spindle tapered roller bearings seat properly in their races.

When the dial indicator needle stops moving, there will be no spindle end-play and no bearing preload. It is *essential* that you find this point without tightening the spanner nut too much and inadvertently preloading the spindle bearings.



Since it takes great effort to turn the inner spanner nut, you may find it difficult to know if you have gone past the zero end-play point or not. It is easiest to have someone watch the dial while you tighten the inner spanner nut. If you think you may have gone past the zero end-play point, take the time to unload the bearings as described earlier, then re-tighten the inner spanner nut until you know you have reached the correct setting.

10. When you are confident that you have adjusted the inner spanner nut until zero spindle end-play and preload exist, tighten the inner spanner nut an additional $\frac{1}{8}$ " of a turn clockwise to introduce the correct amount of spindle bearing preload (see **Figure 94**).

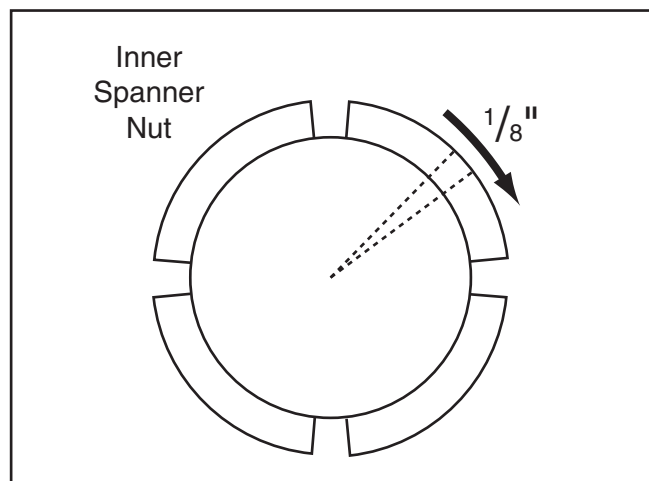

Figure 94. Turning inner spanner nut $\frac{1}{8}$ " clockwise.

11. Without causing the inner spanner nut to tighten any farther, install and tighten the outer spanner nut against the inner nut.

NOTICE

Do not overtighten the outer spanner nut because additional pressure can force the bearings even tighter against the races in the headstock and cause the headstock to compress, crack, or cause bearing failure.

To confirm that the spindle bearings are correctly preloaded:

1. Re-attach all removed lathe components and prepare it for operation.
2. Install the chuck and tighten the jaws into the center.
3. Set the spindle speed to a medium setting.
4. Connect the lathe to power and turn the lathe spindle **ON**.
5. Let the lathe run for 20 minutes.
6. Turn the spindle **OFF**, disconnect the lathe from power, remove the chuck, then check the temperature of the spindle.

— If the spindle nose is slightly warm to the touch, you have correct bearing preload.

— If the spindle nose is hotter than you can comfortably keep your hand on, the preload is too tight and you must repeat the bearing preload adjustment procedure. When repeating the procedure, rotate the inner spanner nut a little less during **Step 10** in the preceding instructions.



SECTION 8: WIRING

These pages are current at the time of printing. However, in the spirit of improvement, we may make changes to the electrical systems of future machines. Compare the manufacture date of your machine to the one stated in this manual, and study this section carefully.

If there are differences between your machine and what is shown in this section, call Technical Support at (570) 546-9663 for assistance BEFORE making any changes to the wiring on your machine. An updated wiring diagram may be available. **Note:** *Please gather the serial number and manufacture date of your machine before calling. This information can be found on the main machine label.*

WARNING

Wiring Safety Instructions

SHOCK HAZARD. Working on wiring that is connected to a power source is extremely dangerous. Touching electrified parts will result in personal injury including but not limited to severe burns, electrocution, or death. Disconnect the power from the machine before servicing electrical components!

MODIFICATIONS. Modifying the wiring beyond what is shown in the diagram may lead to unpredictable results, including serious injury or fire. This includes the installation of unapproved after-market parts.

WIRE CONNECTIONS. All connections must be tight to prevent wires from loosening during machine operation. Double-check all wires disconnected or connected during any wiring task to ensure tight connections.

CIRCUIT REQUIREMENTS. You MUST follow the requirements at the beginning of this manual when connecting your machine to a power source.

WIRE/COMPONENT DAMAGE. Damaged wires or components increase the risk of serious personal injury, fire, or machine damage. If you notice that any wires or components are damaged while performing a wiring task, replace those wires or components.

MOTOR WIRING. The motor wiring shown in these diagrams is current at the time of printing but may not match your machine. If you find this to be the case, use the wiring diagram inside the motor junction box.















CAPACITORS/INVERTERS. Some capacitors and power inverters store an electrical charge for up to 10 minutes after being disconnected from the power source. To reduce the risk of being shocked, wait at least this long before working on capacitors.

EXPERIENCING DIFFICULTIES. If you are experiencing difficulties understanding the information included in this section, contact our Technical Support at (570) 546-9663.

NOTICE

The photos and diagrams included in this section are best viewed in color. You can view these pages in color at www.grizzly.com.

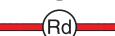
COLOR KEY

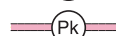
BLACK 	BLUE 	YELLOW 	LIGHT BLUE 
WHITE 	BROWN 	YELLOW GREEN 	BLUE WHITE 
GREEN 	GRAY 	PURPLE 	TURQUOISE 
RED 	ORANGE 	PINK 	



Wiring Diagram

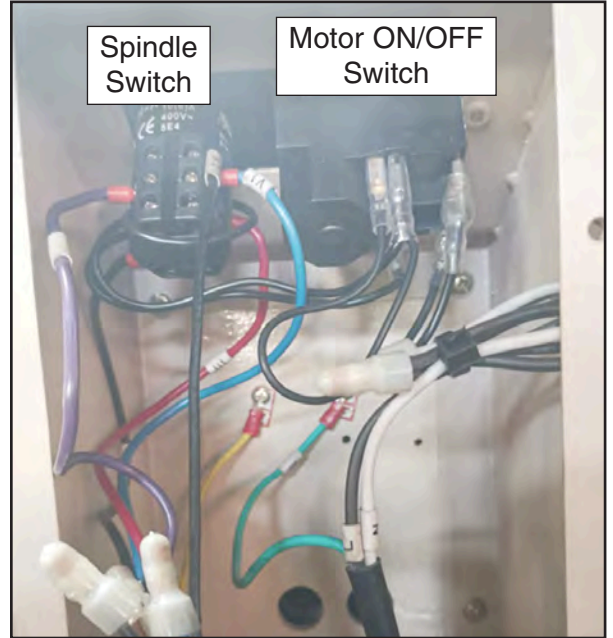
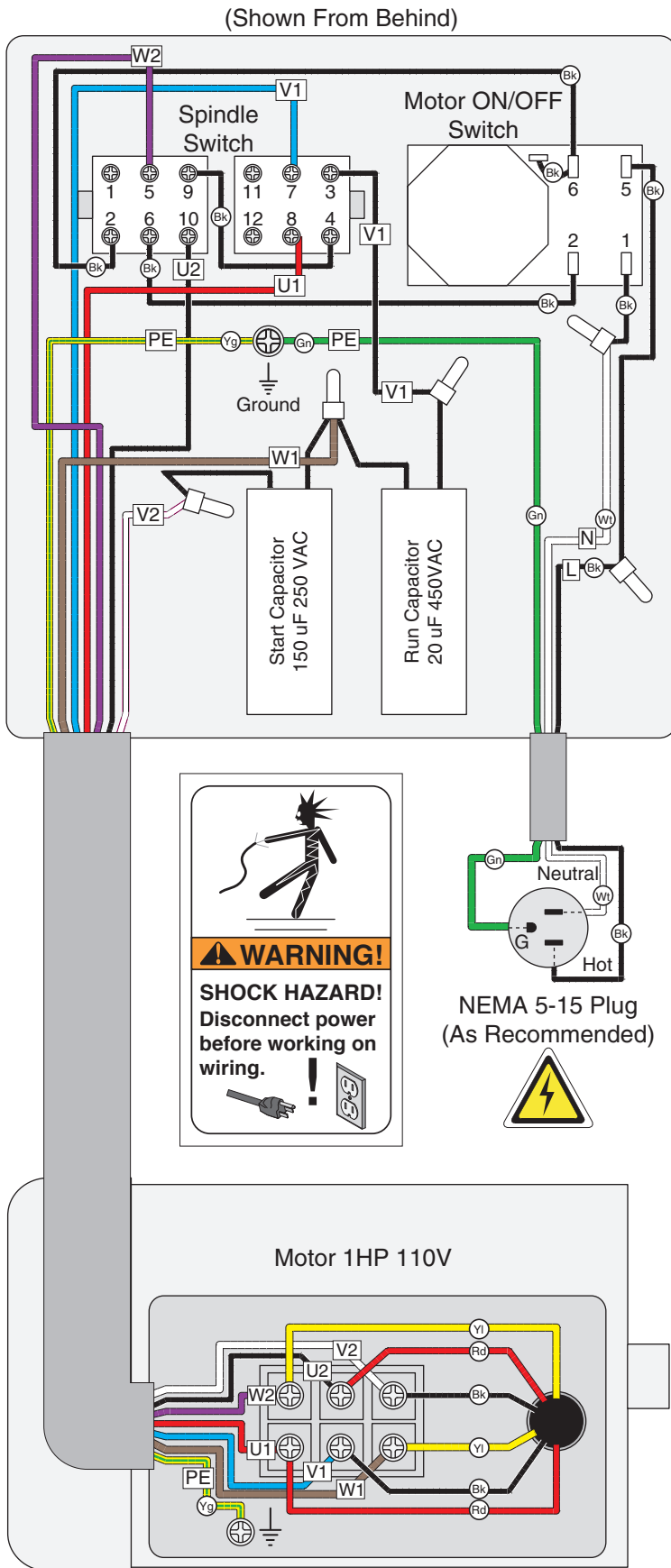

Figure 95. Switch wiring.



Figure 96. Capacitor wiring.

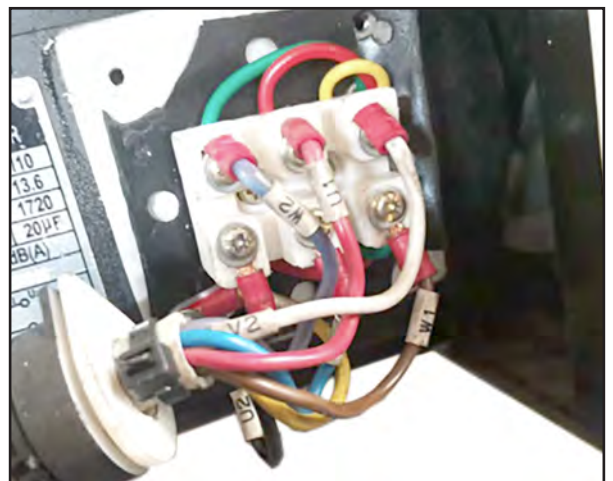
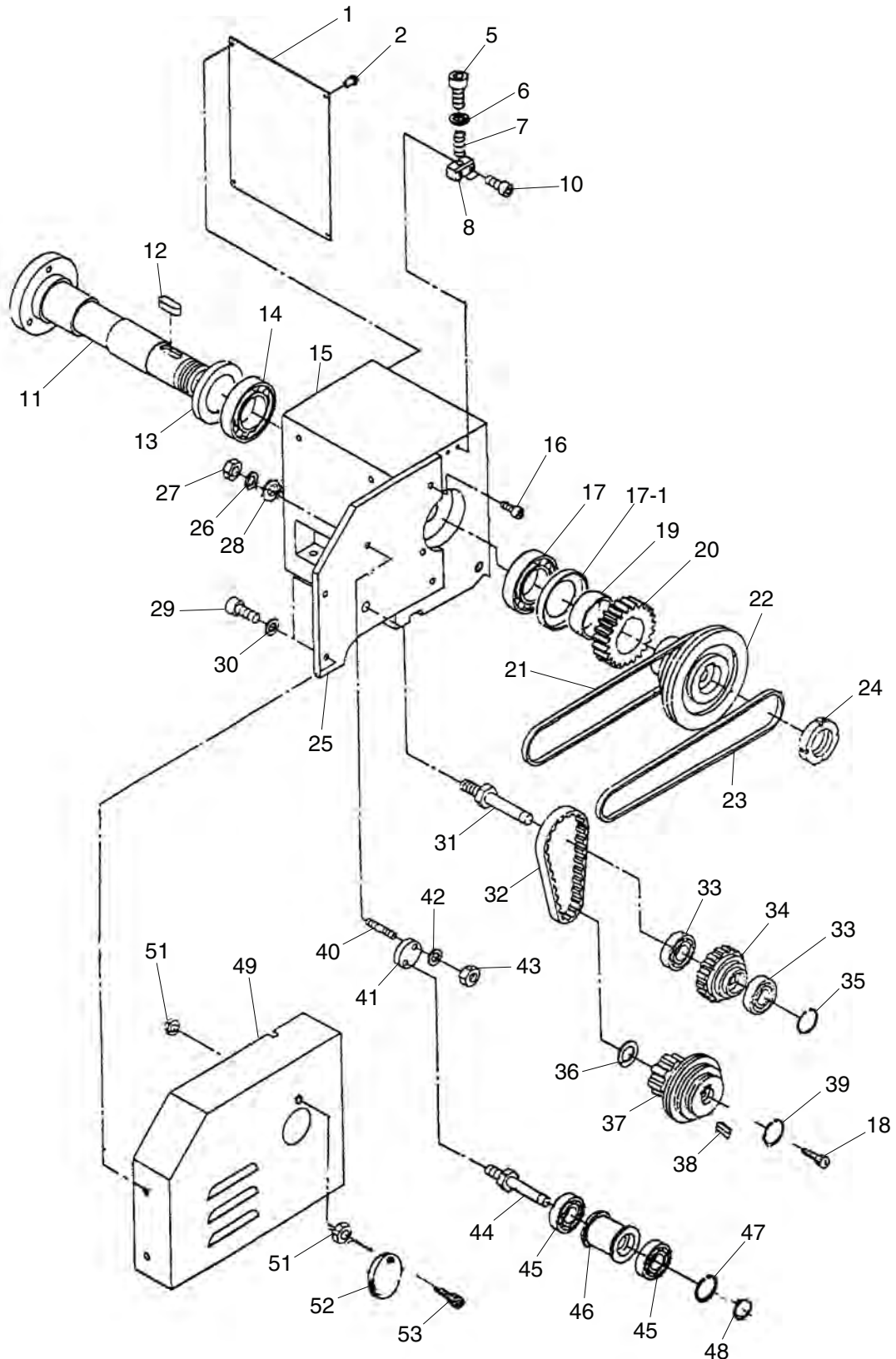

Figure 97. Motor wiring.



SECTION 9: PARTS

Headstock



Headstock Parts List

REF	PART #	DESCRIPTION
1	P9972Z0001	HEADSTOCK NAMEPLATE
2	P9972Z0002	PHLP HD SCR M4-.7 X 6
5	P9972Z0005	CAP SCREW M6-1 X 25
6	P9972Z0006	FLAT WASHER 6MM
7	P9972Z0007	COMPRESSION SPRING .8 X 8 X 20
8	P9972Z0008	THREADED BLOCK
10	P9972Z0010	CAP SCREW M6-1 X 25
11	P9972Z0011	SPINDLE
12	P9972Z0012	KEY 10 X 10 X 55
13	P9972Z0013	SPACER
14	P9972Z0014	TAPER ROLLER BEARING 32009
15	P9972Z0015	HEADSTOCK CASTING
16	P9972Z0016	CAP SCREW M8-1.25 X 20
17	P9972Z0017	TAPER ROLLER BEARING 32009
17-1	P9972Z0017-1	BEARING CAP
18	P9972Z0018	PHLP HD SCR M6-1 X 20
19	P9972Z0019	SPACER
20	P9972Z0020	GEAR 45T
21	P9972Z0021	V-BELT M-29 3L290
22	P9972Z0022	SPINDLE PULLEY
23	P9972Z0023	V-BELT M-32 3L320
24	P9972Z0024	SPANNER NUT M30-3.5
25	P9972Z0025	BRACKET PLATE
26	P9972Z0026	LOCK WASHER 10MM
27	P9972Z0027	HEX NUT M10-1.5

REF	PART #	DESCRIPTION
28	P9972Z0028	FLAT WASHER 10MM
29	P9972Z0029	CAP SCREW M5-.8 X 10
30	P9972Z0030	FLAT WASHER 30MM
31	P9972Z0031	IDLER SHAFT
32	P9972Z0032	TIMING BELT
33	P9972Z0033	BALL BEARING 6001 2RS
34	P9972Z0034	IDLER PULLEY
35	P9972Z0035	INT RETAINING RING 12MM
36	P9972Z0036	FLAT WASHER 18MM
37	P9972Z0037	MOTOR PULLEY
38	P9972Z0038	KEY 6 X 6 X 40
39	P9972Z0039	INT RETAINING RING 10MM
40	P9972Z0040	THREADED HANDLE ROD
41	P9972Z0041	PIVOT BRACKET
42	P9972Z0042	FLAT WASHER 10MM
43	P9972Z0043	HEX NUT M10-1.5
44	P9972Z0044	TENSIONING SHAFT
45	P9972Z0045	BALL BEARING 6001 2RS
46	P9972Z0046	IDLER ROLLER
47	P9972Z0047	INT RETAINING RING 28MM
48	P9972Z0048	EXT RETAINING RING 12MM
49	P9972Z0049	CHANGE GEAR COVER
51	P9972Z0051	HEX NUT M5-.8
52	P9972Z0052	OUTBOUND SPINDLE COVER
53	P9972Z0053	PHLP HD SCR M5-.8 X 12

Please Note: We do our best to stock replacement parts whenever possible, but we cannot guarantee that all parts shown here are available for purchase. Call (800) 523-4777 or visit our online parts store at www.grizzly.com to check for availability.



Change Gears

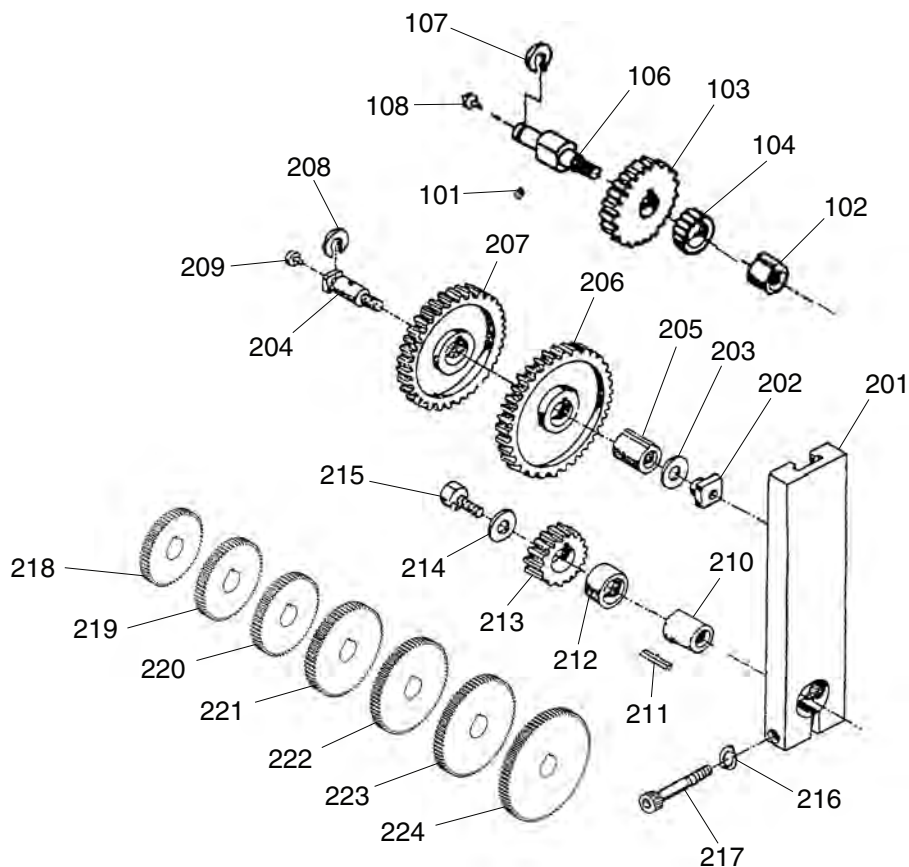

REF	PART #	DESCRIPTION
101	P9972Z0101	SET SCREW M6-1 X 10
102	P9972Z0102	BUSHING
103	P9972Z0103	GEAR 45T
104	P9972Z0104	GEAR 24T
106	P9972Z0106	SHAFT
107	P9972Z0107	CLIPPED WASHER 8MM
108	P9972Z0108	BALL OILER 6MM PRESS-IN
201	P9972Z0201	CHANGE GEAR BRACKET
202	P9972Z0202	PULLEY SHAFT SQUARE NUT
203	P9972Z0203	FLAT WASHER 6MM
204	P9972Z0204	SHAFT
205	P9972Z0205	KEYED BUSHING
206	P9972Z0206	GEAR 127T
207	P9972Z0207	GEAR 120T
208	P9972Z0208	RETAINING CLIP
209	P9972Z0209	BALL OILER 6MM PRESS-IN

REF	PART #	DESCRIPTION
210	P9972Z0210	BUSHING
211	P9972Z0211	KEY 4 X 4 X 14
212	P9972Z0212	SPACER
213	P9972Z0213	GEAR 84T
214	P9972Z0214	FLAT WASHER 6MM
215	P9972Z0215	CAP SCREW M6-1 X 10
216	P9972Z0216	LOCK WASHER 8MM
217	P9972Z0217	CAP SCREW M8-1.25 X 40
218	P9972Z0218	GEAR 28T
219	P9972Z0219	GEAR 35T
220	P9972Z0220	GEAR 63T
221	P9972Z0221	GEAR 69T
222	P9972Z0222	GEAR 70T
223	P9972Z0223	GEAR 77T
224	P9972Z0224	GEAR 78T



Feed Rate Gearbox

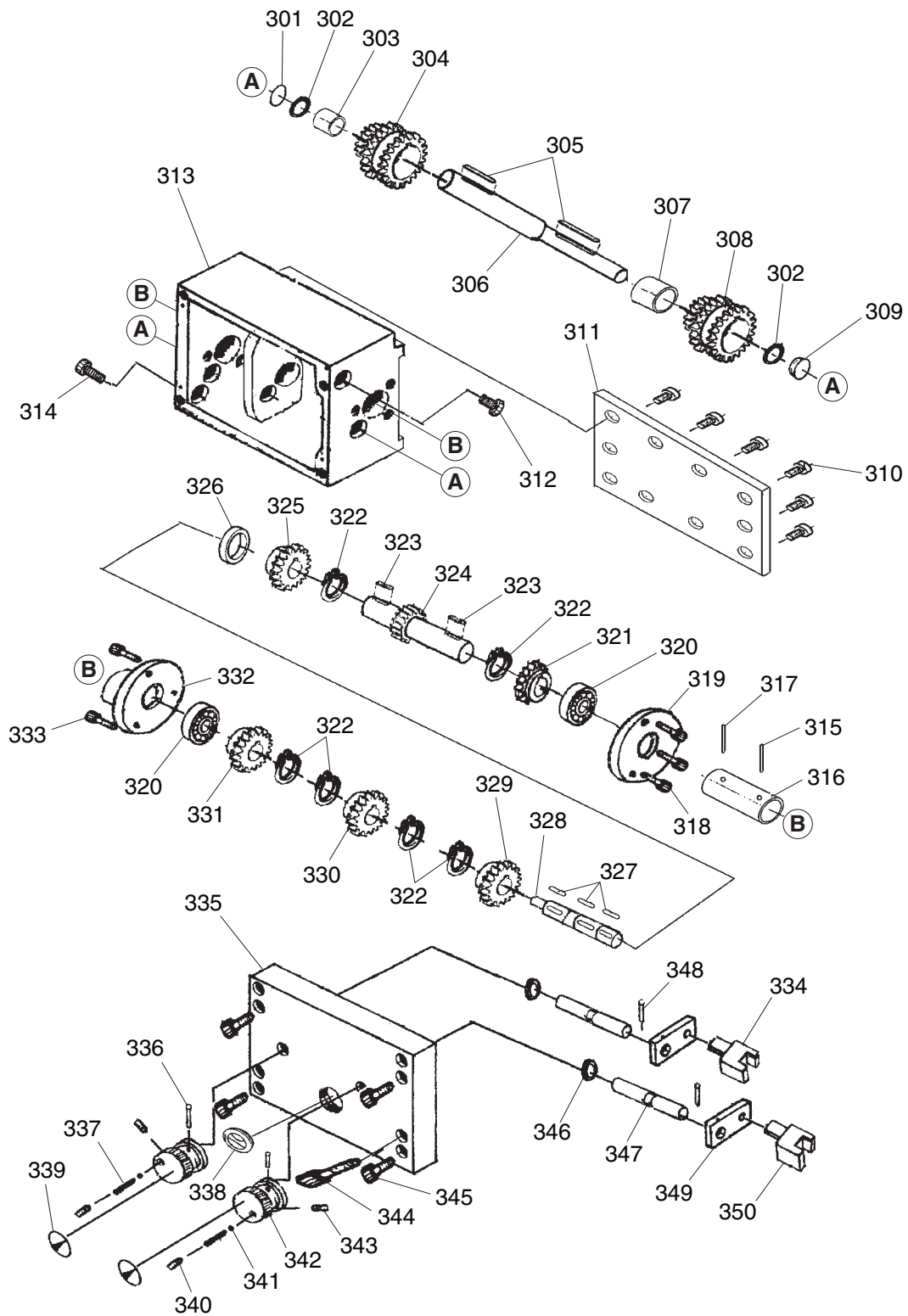

Feed Rate Gearbox Parts List

REF	PART #	DESCRIPTION
301	P9972Z0301	PLUG
302	P9972Z0302	O-RING 17 X 1.8
303	P9972Z0303	BUSHING
304	P9972Z0304	COMBO GEAR 30T/36T/33T
305	P9972Z0305	KEY 3 X 3 X 18
306	P9972Z0306	SHAFT
307	P9972Z0307	BUSHING
308	P9972Z0308	COMBO GEAR 22T/44T/33T
309	P9972Z0309	PLUG
310	P9972Z0310	CAP SCREW M5-.8 X 10
311	P9972Z0311	BACK GEARBOX COVER
312	P9972Z0312	FILL PLUG
313	P9972Z0313	GEARBOX CASTING
314	P9972Z0314	DRAIN PLUG
315	P9972Z0315	DOWELL PIN 5 X 22
316	P9972Z0316	LEADSCREW COLLAR
317	P9972Z0317	BRASS PIN
318	P9972Z0318	CAP SCREW M6-1 X 12
319	P9972Z0319	FLANGE
320	P9972Z0320	BEARING
321	P9972Z0321	GEAR 33T
322	P9972Z0322	EXT RETAINING RING 12MM
323	P9972Z0323	KEY 4 X 4 X 8
324	P9972Z0324	GEAR SHAFT 22T
325	P9972Z0325	GEAR 44T

REF	PART #	DESCRIPTION
326	P9972Z0326	COLLAR
327	P9972Z0327	KEY 4 X 4 X 10
328	P9972Z0328	SHAFT
329	P9972Z0329	GEAR 33T
330	P9972Z0330	GEAR 30T
331	P9972Z0331	GEAR 35T
332	P9972Z0332	FLANGE
333	P9972Z0333	CAP SCREW M6-1 X 16
334	P9972Z0334	SHIFTING FORK
335	P9972Z0335	FRONT GEARBOX COVER
336	P9972Z0336	ROLL PIN 5 X 30
337	P9972Z0337	COMPRESSION SPRING .8 X 4.5 X 18
338	P9972Z0338	OIL SIGHT GLASS
339	P9972Z0339	INDICATOR DISC
340	P9972Z0340	SET SCREW M6-1 X 10
341	P9972Z0341	STEEL BALL 5MM
342	P9972Z0342	SHIFT HUB
343	P9972Z0343	SET SCREW M6-1 X 10
344	P9972Z0344	CAP SCREW M6-1 X 50
345	P9972Z0345	CAP SCREW M6-1 X 20
346	P9972Z0346	O-RING 6 X 1.8
347	P9972Z0347	SHAFT
348	P9972Z0348	ROLL PIN 5 X 20
349	P9972Z0349	SHIFT LEVER
350	P9972Z0350	SHIFTING FORK



Apron

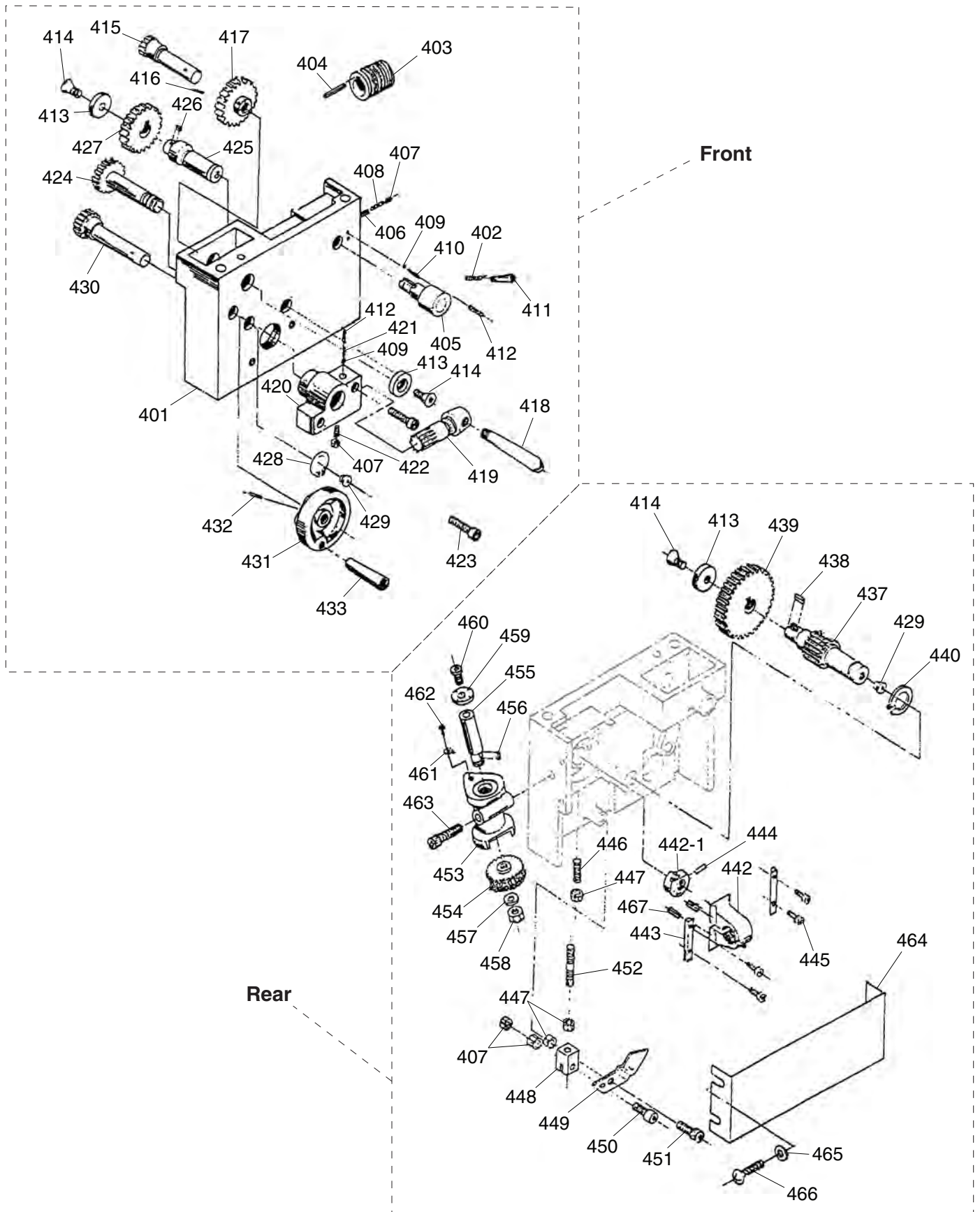

Apron Parts List

REF	PART #	DESCRIPTION
401	P9972Z0401	APRON CASTING
402	P9972Z0402	HANDLE SCREW
403	P9972Z0403	WORM GEAR
404	P9972Z0404	KEY 4 X 5 X 25
405	P9972Z0405	HANDLE HUB
406	P9972Z0406	PIN 4 X 20
407	P9972Z0407	HEX NUT M5-.8
408	P9972Z0408	SET SCREW M5-.8 X 16
409	P9972Z0409	STEEL BALL 5MM
410	P9972Z0410	COMPRESSION SPRING
411	P9972Z0411	HANDLE
412	P9972Z0412	SET SCREW M6-1 X 6
413	P9972Z0413	FLAT WASHER 10MM
414	P9972Z0414	FLAT HD SCR M6-1 X 10
415	P9972Z0415	GEAR SHAFT 12T
416	P9972Z0416	ROLL PIN 4 X 30
417	P9972Z0417	GEAR 43T
418	P9972Z0418	HANDLE
419	P9972Z0419	GEAR SHAFT 13T
420	P9972Z0420	POWER FEED LEVER BRACKET
421	P9972Z0421	COMPRESSION SPRING
422	P9972Z0422	SET SCREW M4-.7 X 10
423	P9972Z0423	CAP SCREW M6-1 X 30
424	P9972Z0424	GEAR SHAFT 36T
425	P9972Z0425	SHAFT
426	P9972Z0426	KEY 4 X 4 X 6
427	P9972Z0427	GEAR 60T
428	P9972Z0428	EXT RETAINING RING 14MM
429	P9972Z0429	BALL OILER 6MM PRESS-IN
430	P9972Z0430	GEAR SHAFT 22T
431	P9972Z0431	HANDWHEEL
432	P9972Z0432	ROLL PIN 4 X 24

REF	PART #	DESCRIPTION
433	P9972Z0433	HANDLE M8-1.25 X 83
437	P9972Z0437	GEAR SHAFT 18T
438	P9972Z0438	KEY 4 X 4 X 12
439	P9972Z0439	GEAR 42T
440	P9972Z0440	EXT RETAINING RING 12MM
442	P9972Z0442	HALF NUT INCH (2PC)
442-1	P9972Z0442-1	HALF NUT BRACKET
443	P9972Z0443	HALF NUT GIB
444	P9972Z0444	ROLL PIN 2 X 35
445	P9972Z0445	CAP SCREW M4-.7 X 16
446	P9972Z0446	SET SCREW M5-.8 X 25
447	P9972Z0447	HEX NUT M5-.8
448	P9972Z0448	CONTROL BLOCK
449	P9972Z0449	PIVOT BRACKET
450	P9972Z0450	CAP SCREW M4-.7 X 20
451	P9972Z0451	CAP SCREW M5-.8 X 16
452	P9972Z0452	STUD-DE M5-.8 X 36 15 15
453	P9972Z0453	THREAD DIAL BODY
454	P9972Z0454	PINION GEAR 32T
455	P9972Z0455	SHAFT
456	P9972Z0456	KEY 3 X 3 X 10
457	P9972Z0457	LOCK WASHER 8MM
458	P9972Z0458	HEX NUT M8-1.25
459	P9972Z0459	THREAD DIAL
460	P9972Z0460	PHLP HD SCR M6-1 X 10
461	P9972Z0461	POINTER
462	P9972Z0462	RIVET 2 X 5MM NAMEPLATE, ALUMINUM
463	P9972Z0463	CAP SCREW M6-1 X 55
464	P9972Z0464	REAR APRON COVER
465	P9972Z0465	FLAT WASHER 4MM
466	P9972Z0466	PHLP HD SCR M4-.7 X 6
467	P9972Z0467	ROLL PIN 5 X 12



Saddle & Cross Slide

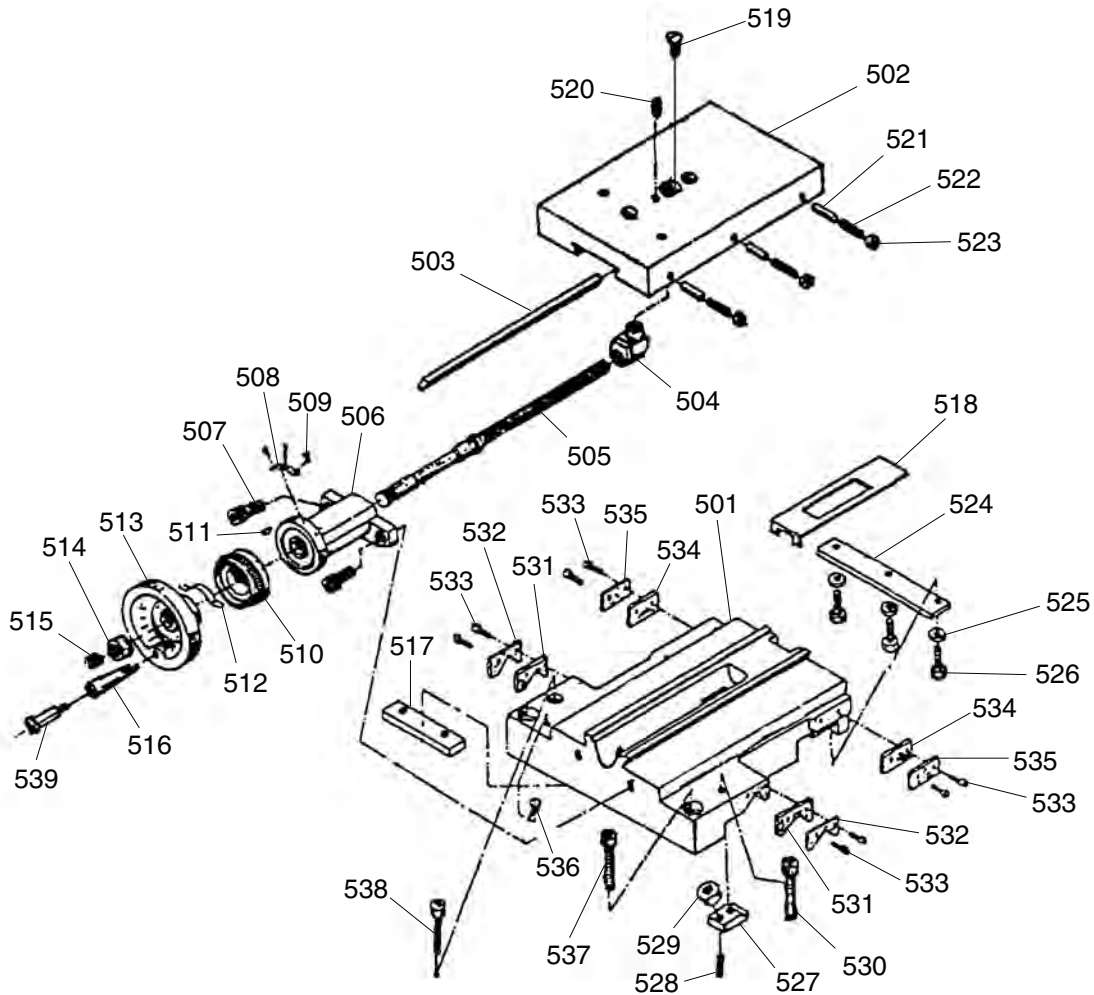

REF	PART #	DESCRIPTION
501	P9972Z0501	SADDLE
502	P9972Z0502	CROSS SLIDE
503	P9972Z0503	CROSS SLIDE GIB
504	P9972Z0504	CROSS SLIDE LEADSCREW NUT
505	P9972Z0505	CROSS SLIDE LEADSCREW
506	P9972Z0506	CROSS SLIDE LEADSCREW BRACKET
507	P9972Z0507	CAP SCREW M8-1.25 X 25
508	P9972Z0508	INDICATOR PLATE
509	P9972Z0509	RIVET 2 X 5MM NAMEPLATE, STEEL
510	P9972Z0510	CROSS SLIDE GRADUATED DIAL
511	P9972Z0511	KEY 3 X 3 X 6
512	P9972Z0512	SPRING PLATE
513	P9972Z0513	HANDWHEEL
514	P9972Z0514	HANDWHEEL RETAINING NUT
515	P9972Z0515	SET SCREW M8-1.25 X 6
516	P9972Z0516	HANDLE
517	P9972Z0517	SLIDE BLOCK
518	P9972Z0518	CHIP GUARD
519	P9972Z0519	CAP SCREW M6-1 X 12
520	P9972Z0520	SET SCREW M6-1 X 16

REF	PART #	DESCRIPTION
521	P9972Z0521	CROSS SLIDE LOCK PIN
522	P9972Z0522	SET SCREW M5-.8 X 16
523	P9972Z0523	HEX NUT M5-.8
524	P9972Z0524	SADDLE GIB
525	P9972Z0525	FLAT WASHER 6MM
526	P9972Z0526	CAP SCREW M6-1 X 16
527	P9972Z0527	CLIP
528	P9972Z0528	SET SCREW M6-1 X 20
529	P9972Z0529	HEX NUT M6-1
530	P9972Z0530	CAP SCREW M6-1 X 35
531	P9972Z0531	NOTCHED WAY WIPER
532	P9972Z0532	NOTCHED WIPER CLAMP
533	P9972Z0533	PHLP HD SCR M4-.7 X 8
534	P9972Z0534	STRAIGHT WAY WIPER
535	P9972Z0535	STRAIGHT WIPER CLAMP
536	P9972Z0536	BALL OILER 6MM PRESS-IN
537	P9972Z0537	CAP SCREW M8-1.25 X 35
538	P9972Z0538	CAP SCREW M6-1 X 35
539	P9972Z0539	HANDLE BOLT



Compound Slide & Tool Post

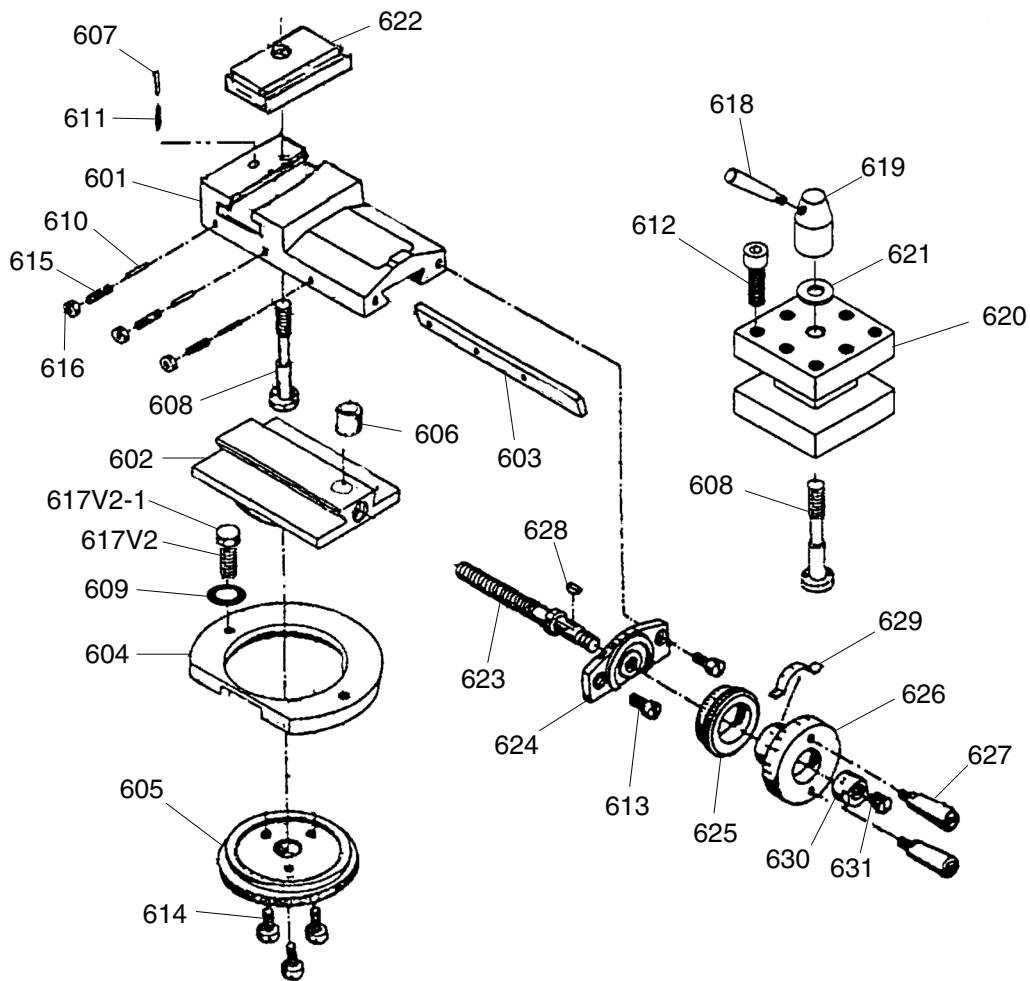

REF	PART #	DESCRIPTION
601	P9972Z0601	COMPOUND SLIDE
602	P9972Z0602	SWIVEL BASE
603	P9972Z0603	COMPOUND SLIDE GIB
604	P9972Z0604	CLAMPING RING
605	P9972Z0605	CLAMPING BASE
606	P9972Z0606	LEADSCREW NUT
607	P9972Z0607	PLUNGER
608	P9972Z0608	TOOL POST STUD
609	P9972Z0609	FLAT WASHER 8MM
610	P9972Z0610	SLIDE LOCK PIN
611	P9972Z0611	COMPRESSION SPRING
612	P9972Z0612	TOOL POST CAP SCREW
613	P9972Z0613	CAP SCREW M8-1.25 X 25
614	P9972Z0614	CAP SCREW M6-1 X 12
615	P9972Z0615	SET SCREW M5-.8 X 16
616	P9972Z0616	HEX NUT M5-.8

REF	PART #	DESCRIPTION
617V2	P9972Z0617V2	SET SCREW M8-1.25 X 40
617V2-1	P9972Z0617V2-1	HEX NUT M8-1.25
618	P9972Z0618	TOOL POST HANDLE
619	P9972Z0619	TOOL POST HANDLE HUB
620	P9972Z0620	TOOL POST BODY
621	P9972Z0621	HUB FLAT WASHER
622	P9972Z0622	TOOL REST BASE
623	P9972Z0623	COMPOUND SLIDE LEADSCREW
624	P9972Z0624	LEADSCREW BRACKET
625	P9972Z0625	GRADUATED DIAL
626	P9972Z0626	HANDWHEEL
627	P9972Z0627	HANDLE
628	P9972Z0628	KEY 3 X 3 X 8
629	P9972Z0629	SPRING PLATE
630	P9972Z0630	THREADED COLLAR
631	P9972Z0631	SET SCREW M8-1.25 X 16



Tailstock

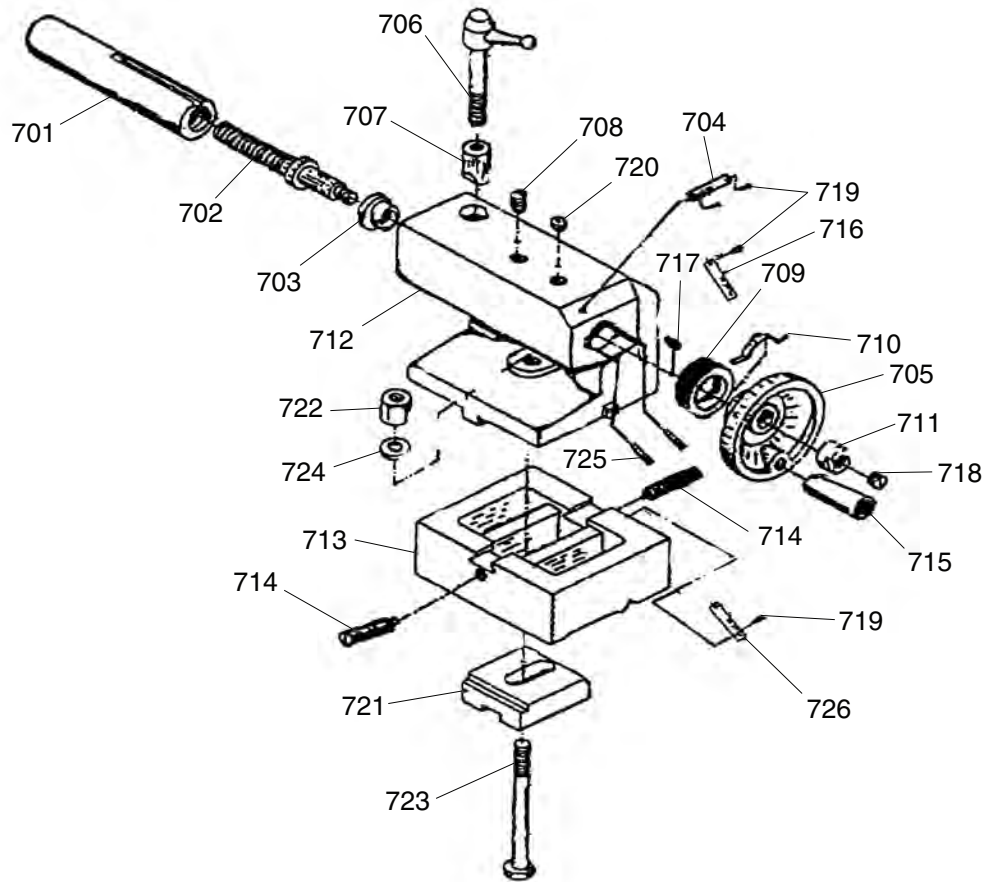

REF	PART #	DESCRIPTION
701	P9972Z0701	TAILSTOCK QUILL MT#3
702	P9972Z0702	TAILSTOCK LEADSCREW
703	P9972Z0703	BUSHING
704	P9972Z0704	INDICATOR PLATE
705	P9972Z0705	HANDWHEEL
706	P9972Z0706	QUILL LOCK
707	P9972Z0707	LOCK BUSHING
708	P9972Z0708	SET SCREW M6-1 X 12
709	P9972Z0709	GRADUATED DIAL
710	P9972Z0710	SPRING PLATE
711	P9972Z0711	SPACER
712	P9972Z0712	TAILSTOCK CASTING
713	P9972Z0713	TAILSTOCK BASE

REF	PART #	DESCRIPTION
714	P9972Z0714	SET SCREW M8-1.25 X 25
715	P9972Z0715	HANDLE
716	P9972Z0716	PLATE
717	P9972Z0717	KEY 3 X 3 X 10
718	P9972Z0718	HEX NUT M10-1.5
719	P9972Z0719	RIVET 2 X 5MM NAMEPLATE, STEEL
720	P9972Z0720	OIL PORT 9MM
721	P9972Z0721	CLAMPING PLATE
722	P9972Z0722	CLAMPING PLATE HEX NUT
723	P9972Z0723	HEX BOLT M12-1.75 X 100
724	P9972Z0724	FLAT WASHER 12MM
725	P9972Z0725	SET SCREW M5-.8 X 6
726	P9972Z0726	INDICATOR PLATE



Bed

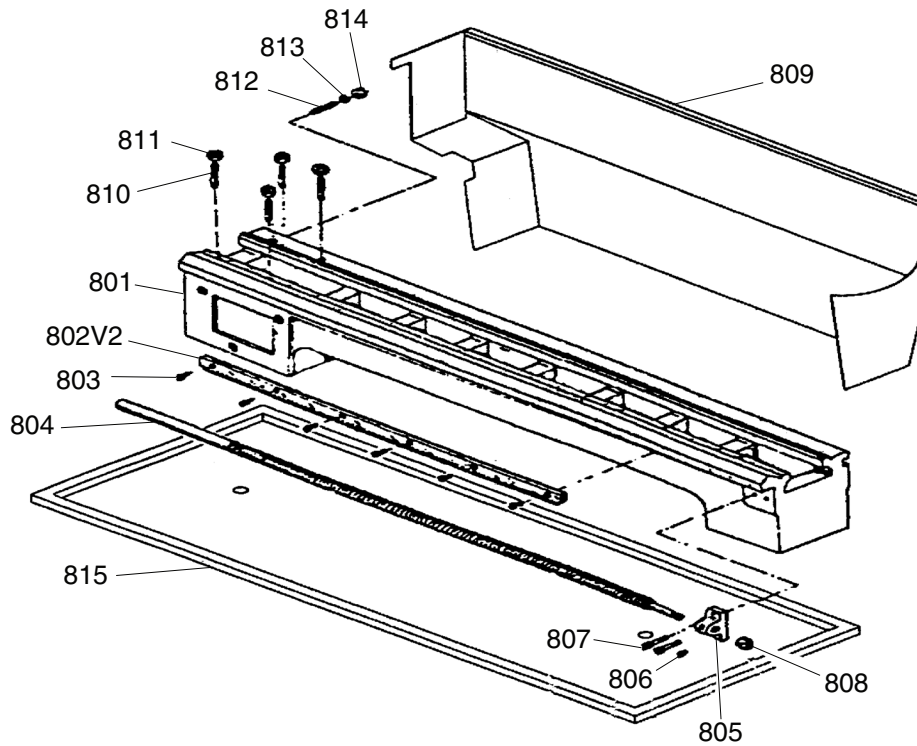

REF	PART #	DESCRIPTION
801	P9972Z0801	BED
802V2	P9972Z0802V2	RACK V2.01.22
803	P9972Z0803	CAP SCREW M5-.8 X 12
804	P9972Z0804	FEED LEADSCREW INCH
805	P9972Z0805	LEADSCREW END BRACKET
806	P9972Z0806	BALL OILER 6MM PRESS-IN
807	P9972Z0807	CAP SCREW M6-1 X 20
808	P9972Z0808	HEX NUT M10-1.5

REF	PART #	DESCRIPTION
809	P9972Z0809	SPLASH GUARD
810	P9972Z0810	STUD-SE M10-1.5 X 45 35
811	P9972Z0811	HEX NUT M10-1.5
812	P9972Z0812	SET SCREW M8-1.25 X 40
813	P9972Z0813	FLAT WASHER 8MM
814	P9972Z0814	HEX NUT M8-1.25
815	P9972Z0815	CHIP PAN



Steady Rest

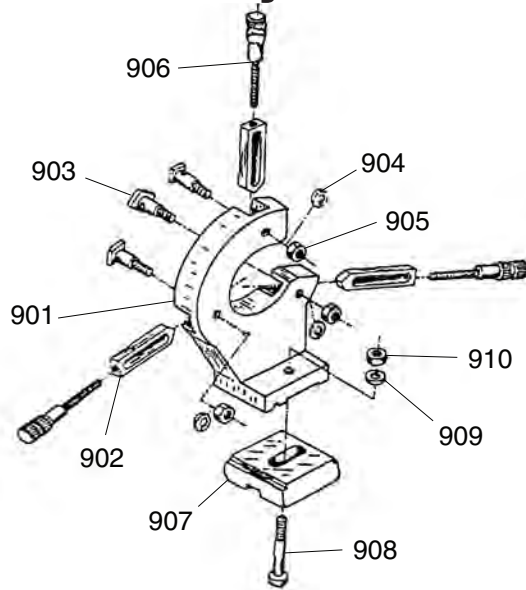

REF	PART #	DESCRIPTION
901	P9972Z0901	STEADY REST CASTING
902	P9972Z0902	FINGER
903	P9972Z0903	FINGER T-BOLT
904	P9972Z0904	LOCK WASHER 8MM
905	P9972Z0905	HEX NUT M8-1.25

REF	PART #	DESCRIPTION
906	P9972Z0906	ADJUSTING SCREW
907	P9972Z0907	CLAMPING PLATE
908	P9972Z0908	HEX BOLT M12-1.75 X 65
909	P9972Z0909	FLAT WASHER 12MM
910	P9972Z0910	HEX NUT M12-1.75

Follow Rest

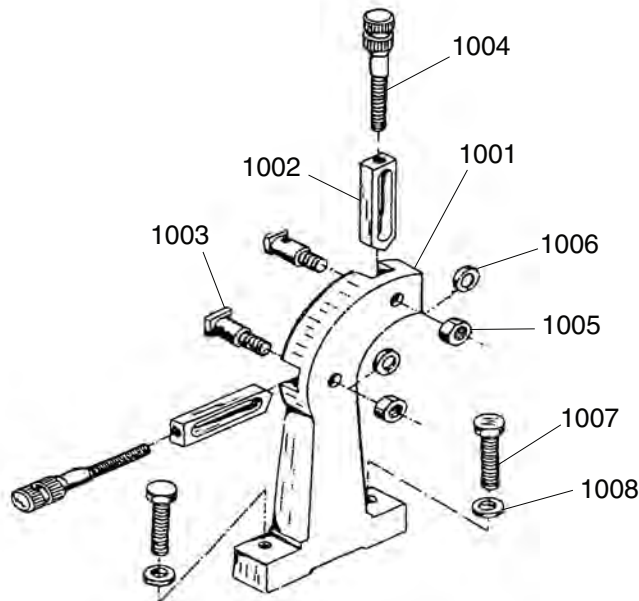

REF	PART #	DESCRIPTION
1001	P9972Z1001	FOLLOW REST CASTING
1002	P9972Z1002	FINGER
1003	P9972Z1003	FINGER T-BOLT
1004	P9972Z1004	ADJUSTING SCREW

REF	PART #	DESCRIPTION
1005	P9972Z1005	HEX NUT M8-1.25
1006	P9972Z1006	FLAT WASHER 8MM
1007	P9972Z1007	CAP SCREW M8-1.25 X 35
1008	P9972Z1008	FLAT WASHER 8MM



Electrical Components

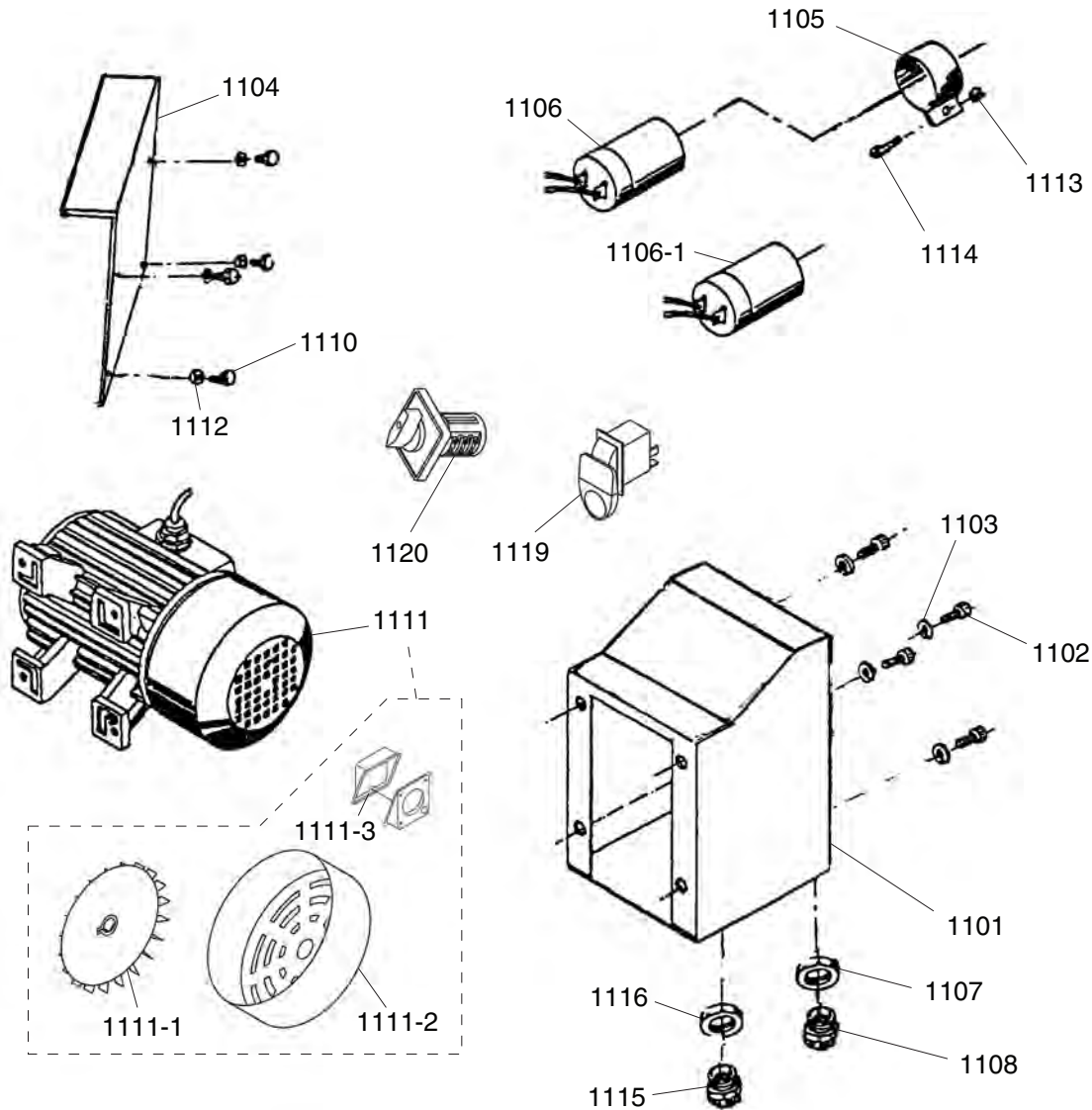

REF	PART #	DESCRIPTION
1101	P9972Z1101	ELECTRICAL CABINET
1102	P9972Z1102	CAP SCREW M6-1 X 25
1103	P9972Z1103	LOCK WASHER 6MM
1104	P9972Z1104	ELECTRICAL CABINET COVER
1105	P9972Z1105	CAPACITOR COVER W/CLIP
1106	P9972Z1106	S CAPACITOR 150M 250V 1-5/8 X 3-1/4
1106-1	P9972Z1106-1	R CAPACITOR 20M 450V 1-3/4 X 3-3/4
1107	P9972Z1107	STRAIN RELIEF NUT 1/2"
1108	P9972Z1108	STRAIN RELIEF 1/2"
1110	P9972Z1110	PHLP HD SCR M5-.8 X 10
1111	P9972Z1111	MOTOR 1HP 110V 1PH

REF	PART #	DESCRIPTION
1111-1	P9972Z1111-1	MOTOR FAN
1111-2	P9972Z1111-2	MOTOR FAN COVER
1111-3	P9972Z1111-3	MOTOR WIRING JUNCTION BOX
1112	P9972Z1112	LOCK WASHER 5MM
1113	P9972Z1113	HEX NUT M4-.7
1114	P9972Z1114	PHLP HD SCR M4-.7 X 20
1115	P9972Z1115	STRAIN RELIEF 3/4"
1116	P9972Z1116	STRAIN RELIEF NUT 3/4"
1119	P9972Z1119	ON/OFF SWITCH W/COVER
1120	P9972Z1120	FWD/REV SWITCH KEDU EN61058



Accessories

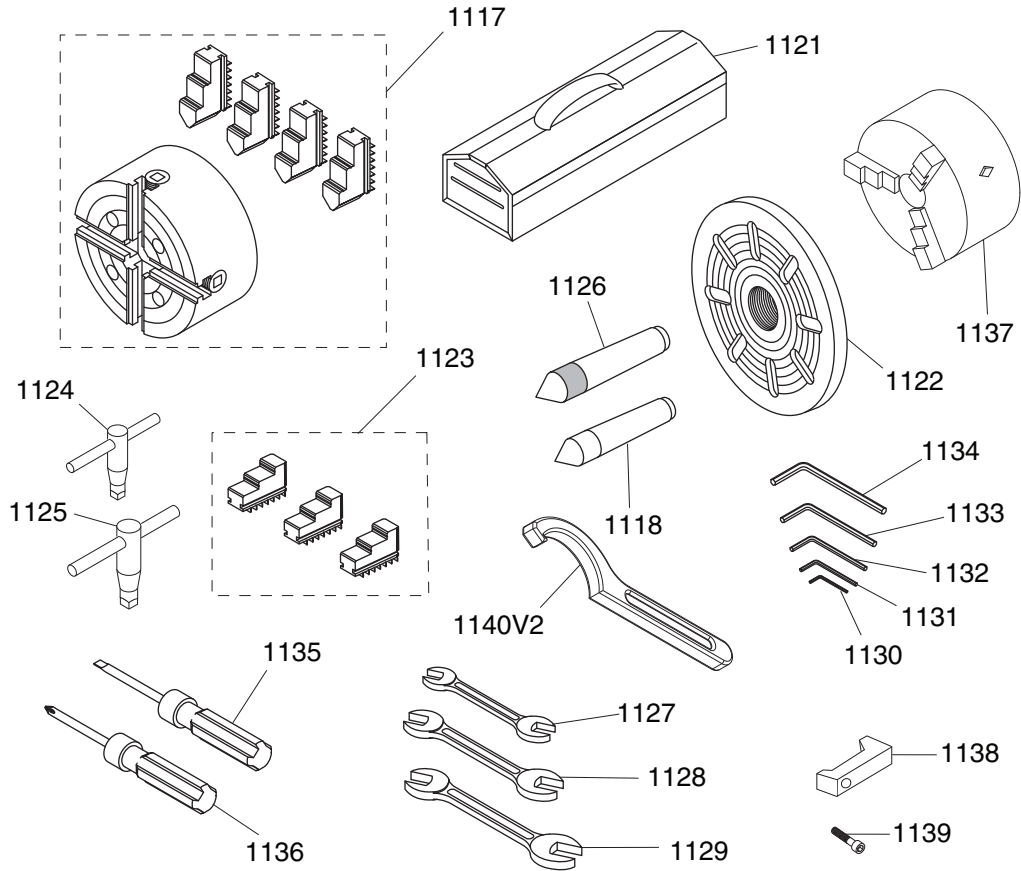

REF	PART #	DESCRIPTION	REF	PART #	DESCRIPTION
1117V2	P9972Z1117V2	4-JAW CHUCK 6-1/4" V2.01.16	1130	P9972Z1130	HEX WRENCH 3MM
1118	P9972Z1118	DEAD CENTER MT#3	1131	P9972Z1131	HEX WRENCH 4MM
1121	P9972Z1121	TOOL BOX	1132	P9972Z1132	HEX WRENCH 5MM
1122	P9972Z1122	FACEPLATE 8"	1133	P9972Z1133	HEX WRENCH 6MM
1123	P9972Z1123	3-JAW CHUCK REVERSE JAW SET	1134	P9972Z1134	HEX WRENCH 8MM
1124	P9972Z1124	LATHE CHUCK KEY 9.82MM STD	1135	P9972Z1135	SCREWDRIVER FLAT #2
1125V2	P9972ZV21125	LATHE CHUCK KEY 9.82MM STD	1136	P9972Z1136	SCREWDRIVER PHILLIPS #2
1126	P9972Z1126	DEAD CENTER MT#3 CARBIDE-TIPPED	1137	P9972Z1137	3-JAW CHUCK
1127	P9972Z1127	WRENCH 8 X 10MM OPEN-ENDS	1138	P9972Z1138	SPINDLE CLAMP
1128	P9972Z1128	WRENCH 12 X 14MM OPEN-ENDS	1139	P9972Z1139	CAP SCREW M6-1 X 20
1129	P9972Z1129	WRENCH 17 X 19MM OPEN-ENDS	1140V2	P9972Z1140V2	SPANNER WRENCH V2.04.20



Labels & Cosmetics

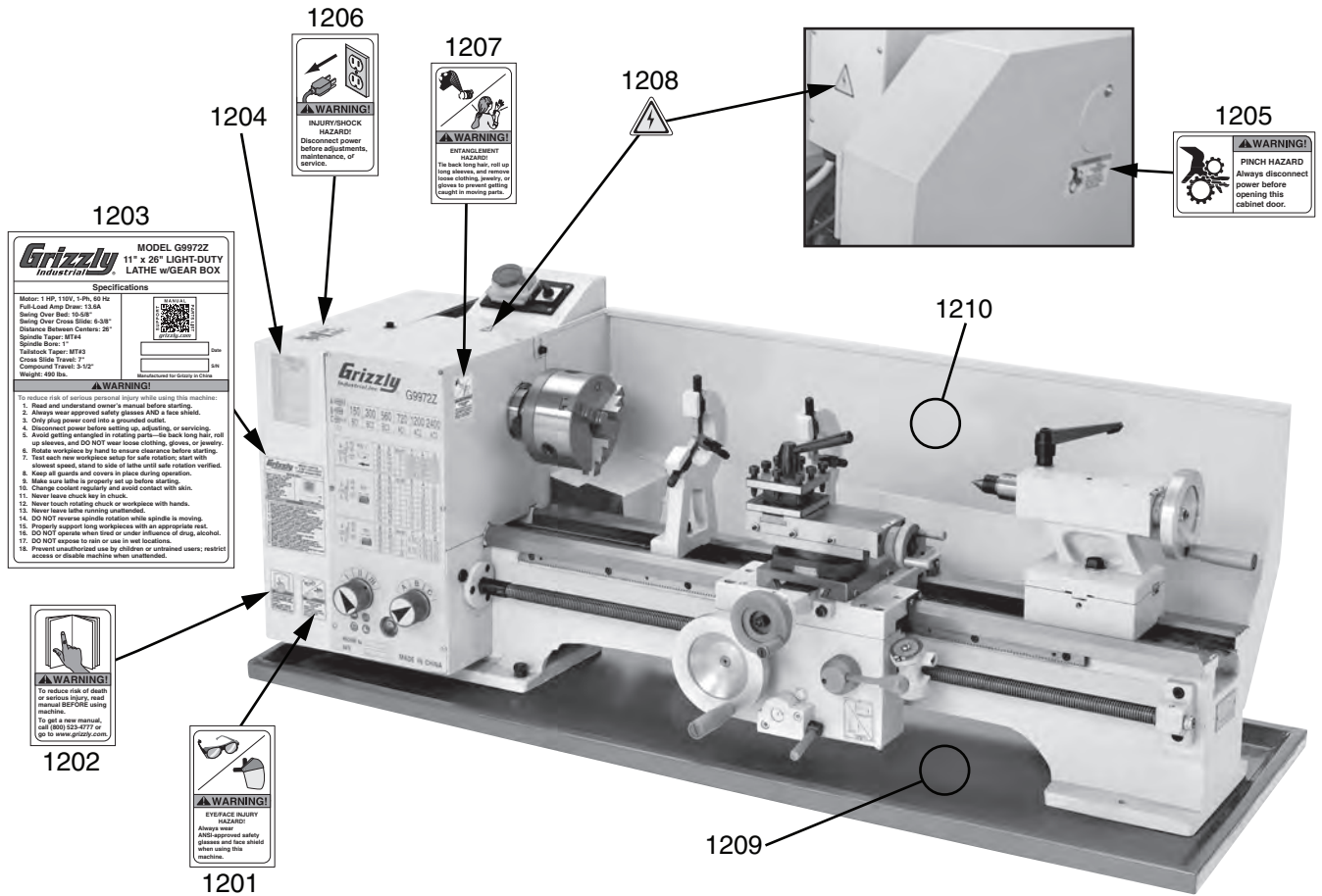

REF	PART #	DESCRIPTION
1201	P9972Z1201	EYE/FACE INJURY LABEL
1202	P9972Z1202	READ MANUAL LABEL
1203	P9972Z1203	MACHINE ID LABEL
1204	P9972Z1204	THREAD DIAL CHART LABEL
1205	P9972Z1205	PINCH HAZARD LABEL

REF	PART #	DESCRIPTION
1206	P9972Z1206	DISCONNECT POWER LABEL
1207	P9972Z1207	ENTANGLEMENT HAZARD LABEL
1208	P9972Z1208	ELECTRICITY LABEL
1209	P9972Z1209	TOUCH-UP PAINT, GRIZZLY GREEN
1210	P9972Z1210	TOUCH-UP PAINT, GRIZZLY BEIGE

⚠ WARNING

Safety labels help reduce the risk of serious injury caused by machine hazards. If any label comes off or becomes unreadable, the owner of this machine **MUST** replace it in the original location before resuming operations. For replacements, contact (800) 523-4777 or www.grizzly.com.



WARRANTY & RETURNS

Grizzly Industrial, Inc. warrants every product it sells for a period of **1 year** to the original purchaser from the date of purchase. This warranty does not apply to defects due directly or indirectly to misuse, abuse, negligence, accidents, repairs or alterations or lack of maintenance. This is Grizzly's sole written warranty and any and all warranties that may be implied by law, including any merchantability or fitness, for any particular purpose, are hereby limited to the duration of this written warranty. We do not warrant or represent that the merchandise complies with the provisions of any law or acts unless the manufacturer so warrants. In no event shall Grizzly's liability under this warranty exceed the purchase price paid for the product and any legal actions brought against Grizzly shall be tried in the State of Washington, County of Whatcom.

We shall in no event be liable for death, injuries to persons or property or for incidental, contingent, special, or consequential damages arising from the use of our products.

The manufacturers reserve the right to change specifications at any time because they constantly strive to achieve better quality equipment. We make every effort to ensure that our products meet high quality and durability standards and we hope you never need to use this warranty.

In the event you need to use this warranty, contact us by mail or phone and give us all the details. We will then issue you a "Return Number," which must be clearly posted on the outside as well as the inside of the carton. We will not accept any item back without this number. Proof of purchase must accompany the merchandise.

Please feel free to write or call us if you have any questions about the machine or the manual.

Thank you again for your business and continued support. We hope to serve you again soon.

To take advantage of this warranty, you must register it at <https://www.grizzly.com/secureforms/warranty-card>, or you can scan the QR code below to be automatically directed to our warranty registration page. Enter all applicable information for the product.



grizzly.com[®]
TOOL WEBSITE

Buy Direct and Save with Grizzly[®] – Trusted, Proven and a Great Value!
~Since 1983~

*Visit Our Website Today For
Current Specials!*

**ORDER
24 HOURS A DAY!
1-800-523-4777**

