

READ THIS FIRST



**Models G0544/G5850Z/
G5851Z/G7213Z**

*****IMPORTANT UPDATE*****

**For Machines Mfd. Since 12/16
and Owner's Manual Revised 03/06**

For questions or help with this product contact Tech Support at (570) 546-9663 or techsupport@grizzly.com

The following changes were recently made to this machine since the owner's manual was printed:

- Updated electrical component information and parts list.
- Updated wiring diagram.
- Updated belt size.

Aside from this information, all other content in the owner's manual applies and MUST be read and understood for your own safety. **IMPORTANT: Keep this update with the owner's manual for future reference.**

For questions or help, contact our Tech Support at (570) 546-9663 or techsupport@grizzly.com.

Revised G0544, G5850Z & G5851Z Breakdown & Parts List

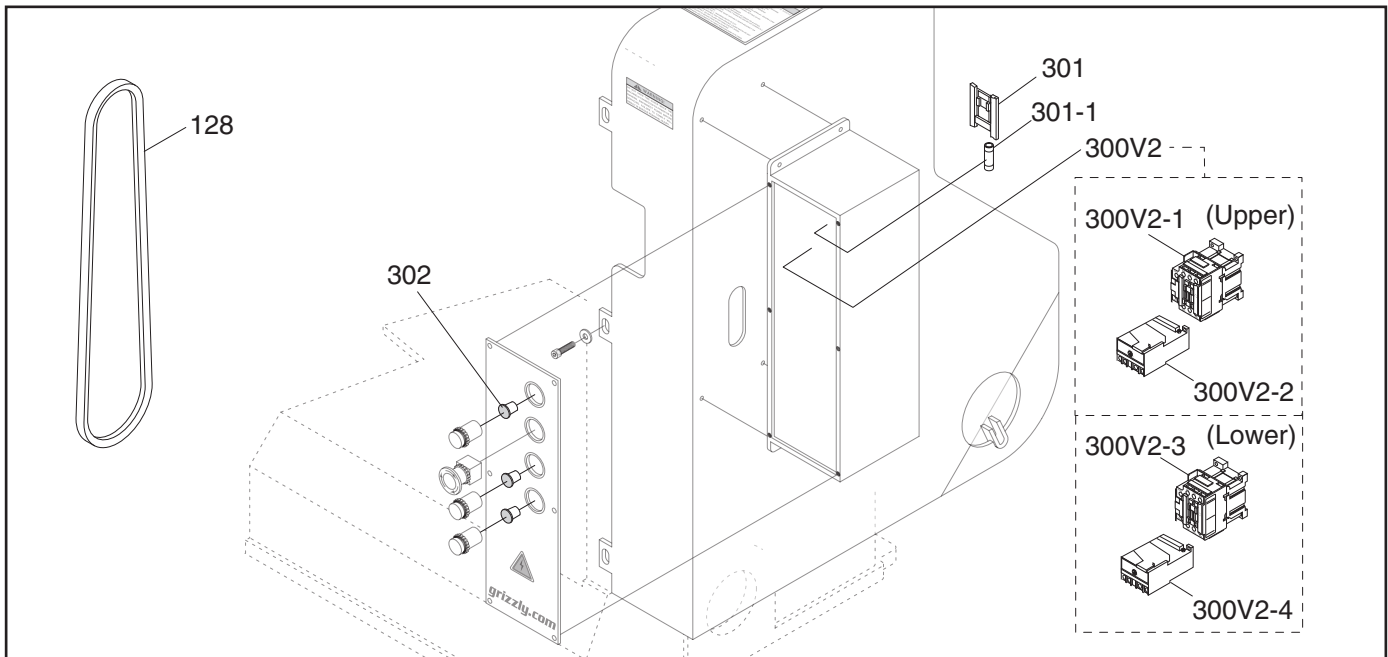

REF	PART #	DESCRIPTION
128	P5851Z128	BELT A64
300V2	P5850Z300V2	MAG SWITCH ASSY V2.12.16
300V2-1	P5850Z300V2-1	CONTACTOR RIKEN RAB-A18 220V
300V2-2	P5850Z300V2-2	OL RELAY RIKEN BTH-18T-2H18 12-18A
300V2-3	P5850Z300V2-3	CONTACTOR RIEKN RAB-A35 220V

REF	PART #	DESCRIPTION
300V2-4	P5850Z300V2-4	OL RELAY RIKEN BTH-352H3624-36A
301	P5850Z301	FUSE HOLDER
301-1	P5850Z301-1	FUSE 2A
302	P5850Z180	INDICATOR LIGHT (220V)

COPYRIGHT © MARCH, 2017 BY GRIZZLY INDUSTRIAL, INC.
**WARNING: NO PORTION OF THIS MANUAL MAY BE REPRODUCED IN ANY SHAPE
OR FORM WITHOUT THE WRITTEN APPROVAL OF GRIZZLY INDUSTRIAL, INC.**

#JH14254 PRINTED IN TAIWAN

V1.07.17

Revised G7213Z Breakdown & Parts List

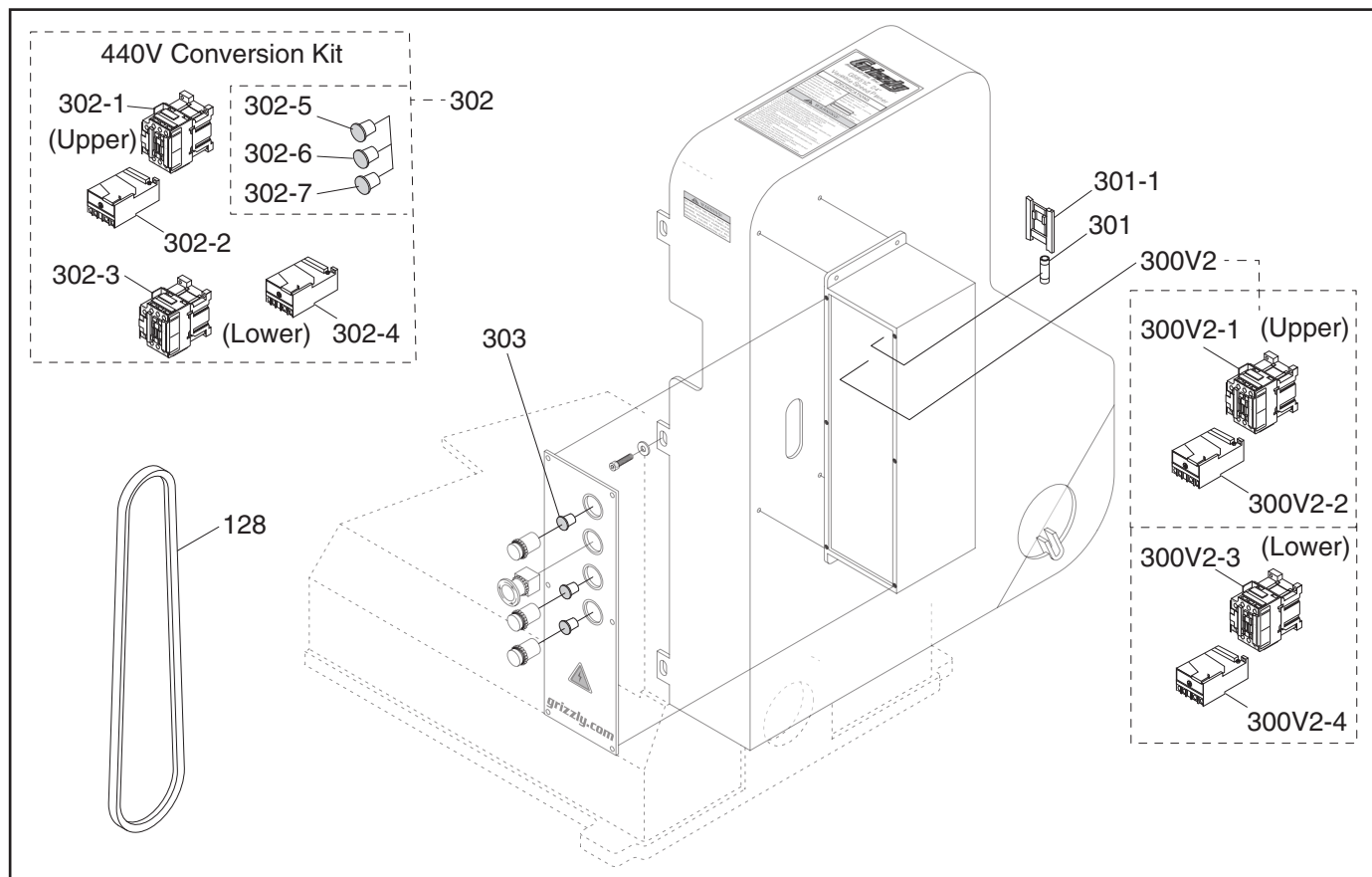

REF	PART #	DESCRIPTION
128	P7213Z128	BELT A64
300V2	P7213Z300V2	MAGNETIC SWITCH ASSY 3-PH V2.12.16
300V2-1	P7213Z300V2-1	CONTACTOR RIKEN RAB-A12 220V V2.12.16
300V2-2	P7213Z300V2-2	OL RELAY RIKEN BTH-18T 2H8 5.4-8A V2.12.16
300V2-3	P7213Z300V2-3	CONTACTOR RIKEN RAB-A30 220V V2.12.16
300V2-4	P7213Z300V2-4	OL RELAY RIKEN BTH-35 2H26 18-26A V2.12.16
301	P7213Z301	FUSE 2A
301-1	P7213Z301-1	FUSE HOLDER
302	P7213Z302	440V CONVERSION KIT

REF	PART #	DESCRIPTION
302-1	P7213Z302-1	CONTACTOR RIKEN RAB-A12 440V
302-2	P7213Z302-2	OL RELAY RIKEN BTH-18T2H4.3 2.9-4.3A
302-3	P7213Z302-3	CONTACTOR RIKEN RAB-A18 440V
302-4	P7213Z302-4	OL RELAY RIKEN BTH-18T2H18 12-18A
302-5	P7213Z302-5	POWER FEED BULB (440V)
302-6	P7213Z302-6	MAIN MOTOR BULB (440V)
302-7	P7213Z302-7	FEED MOTOR BULB (440V)
303	P7213Z303	INDICATOR BULB (220V)



Revised G0544, G5850Z & G5851Z Wiring Diagram

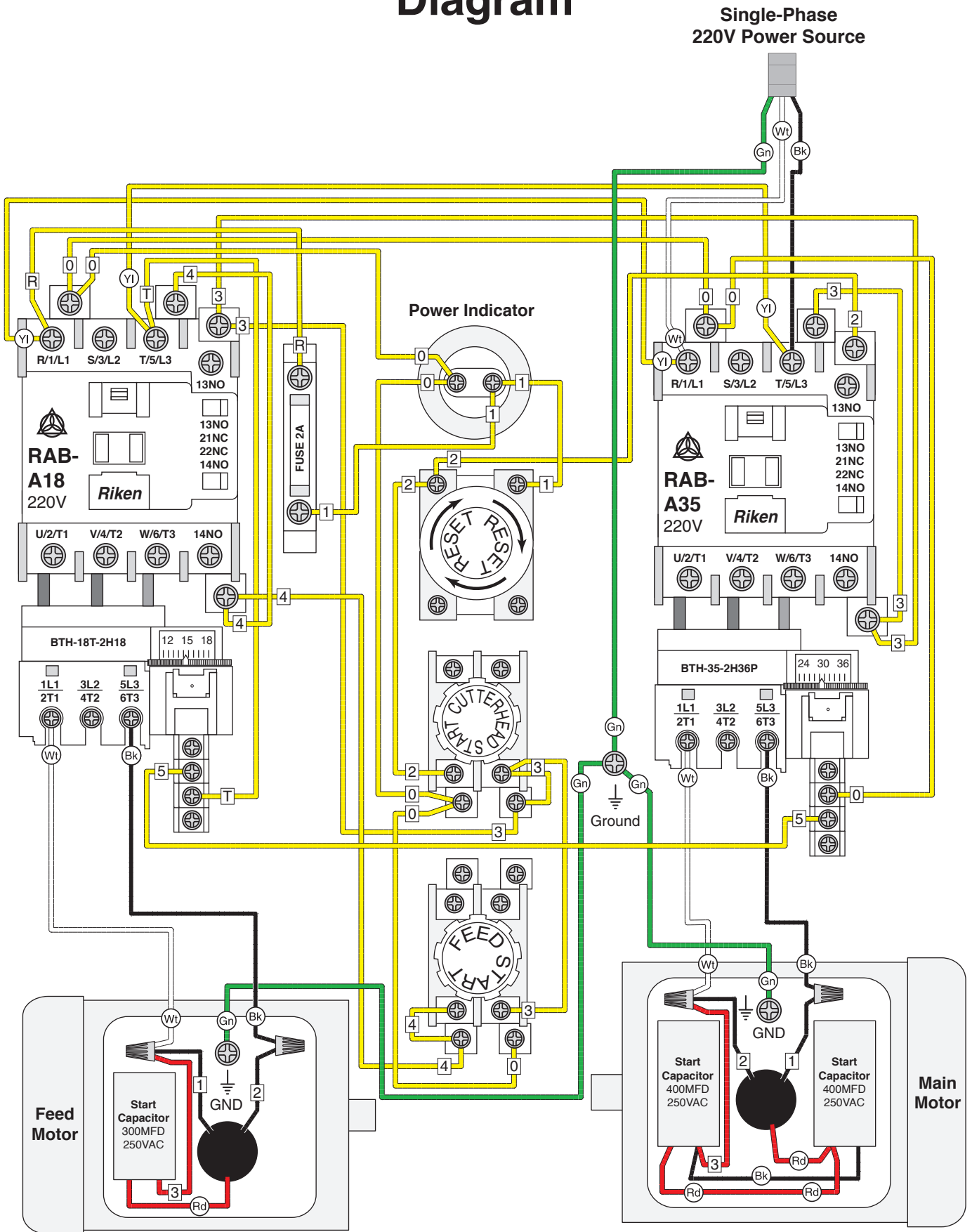

Revised G7213Z 220V Wiring Diagram

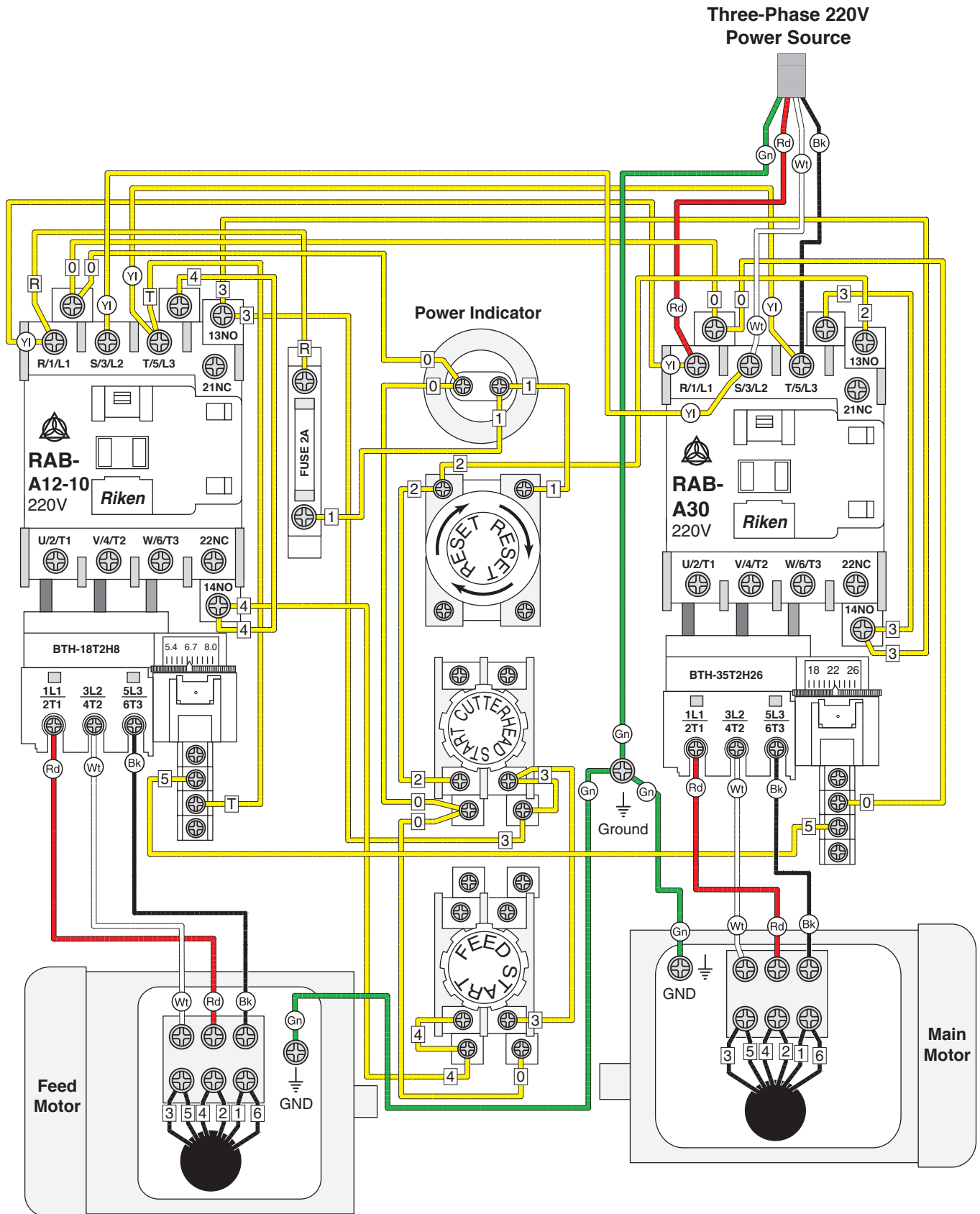

Revised G7213Z 440V Wiring Diagram

Three-Phase 440V
Power Source

Indicates changes
from 220V to 440V

Power Indicator

RAB-
A12-10
440V
Riken

RAB-
A18
440V
Riken

BTH-18T2H4.3

BTH-18T2H18

1L1 3L2 5L3
2T1 4T2 6T3

1L1 3L2 5L3
2T1 4T2 6T3

Feed
Motor

Main
Motor



Grizzly *Industrial, Inc.*®

PROFESSIONAL SERIES PLANERS

MODELS G5850Z/G5851Z/G7213Z/G0544 INSTRUCTION MANUAL



COPYRIGHT © MAY, 2002 BY GRIZZLY INDUSTRIAL, INC. REVISED SEPTEMBER, 2005
**WARNING: NO PORTION OF THIS MANUAL MAY BE REPRODUCED IN ANY SHAPE
OR FORM WITHOUT THE WRITTEN APPROVAL OF GRIZZLY INDUSTRIAL, INC.**
#TR4135 PRINTED IN TAIWAN REVISED MARCH, 2006 (JK)

V1.01.16



WARNING!

This manual provides critical safety instructions on the proper setup, operation, maintenance, and service of this machine/tool. Save this document, refer to it often, and use it to instruct other operators.

Failure to read, understand and follow the instructions in this manual may result in fire or serious personal injury—including amputation, electrocution, or death.

The owner of this machine/tool is solely responsible for its safe use. This responsibility includes but is not limited to proper installation in a safe environment, personnel training and usage authorization, proper inspection and maintenance, manual availability and comprehension, application of safety devices, cutting/sanding/grinding tool integrity, and the usage of personal protective equipment.

The manufacturer will not be held liable for injury or property damage from negligence, improper training, machine modifications or misuse.



WARNING!

Some dust created by power sanding, sawing, grinding, drilling, and other construction activities contains chemicals known to the State of California to cause cancer, birth defects or other reproductive harm. Some examples of these chemicals are:

- **Lead from lead-based paints.**
- **Crystalline silica from bricks, cement and other masonry products.**
- **Arsenic and chromium from chemically-treated lumber.**

Your risk from these exposures varies, depending on how often you do this type of work. To reduce your exposure to these chemicals: Work in a well ventilated area, and work with approved safety equipment, such as those dust masks that are specially designed to filter out microscopic particles.

Table Of Contents

	PAGE
1. SAFETY	
SAFETY RULES FOR ALL TOOLS	2-3
ADDITIONAL SAFETY INSTRUCTIONS FOR PLANERS	4
2. CIRCUIT REQUIREMENTS	5
220V SINGLE-PHASE	5
220V 3-PHASE	5
GROUNDING	6
EXTENSION CORDS	6
3. GENERAL INFORMATION	7
COMMENTARY	7
UNPACKING	8
PIECE INVENTORY	8
HARDWARE RECOGNITION CHART	9
CLEAN UP	10
SITE CONSIDERATIONS	10
4. ASSEMBLY	11
BEGINNING ASSEMBLY	11
DUST HOOD	11
ADJUSTMENT HANDLE	11
5. ADJUSTMENTS	12
ADJUSTMENT CONTROLS	12
CUTTERHEAD KNIVES	13-14
TABLE	15-17
FEED ROLLERS, PRESSURE BAR & CHIP BREAKER	18-19
TABLE ROLLERS	20
FEED ROLLER TENSION	21
TEST RUN	21
6. OPERATION	22
OPERATION CONTROLS	22
FEED RATE	23
OPERATIONAL TIPS	23
WOOD CHARACTERISTICS	24
7. MAINTENANCE	25
GENERAL	25
CLEANING	25
TABLE	25
LUBRICATION	25-26
V-BELT	26
INDEXABLE INSERTS (G0544)	27
G5850Z/G5851Z/G0544 WIRING DIAGRAM	28
G7213Z WIRING DIAGRAM	29
8. CLOSURE	30
G5850Z/G0544 MACHINE DATA	31
G5850Z/G0544 PARTS BREAKDOWN AND PARTS LIST	32-37
G5851Z MACHINE DATA	38
G7213Z MACHINE DATA	39
G5851Z/G7213Z PARTS BREAKDOWN AND PARTS LIST	40-45
WARRANTY AND RETURNS	46

SECTION 1: SAFETY

For Your Own Safety, Read Instruction Manual Before Operating this Power Tool

The purpose of safety symbols is to attract your attention to possible hazardous conditions. This manual uses a series of symbols and signal words intended to convey the level of importance of the safety messages. The progression of symbols is described below. Remember that safety messages by themselves do not eliminate danger and are not a substitute for proper accident prevention measures. Always use common sense and good judgment.



Indicates an imminently hazardous situation which, if not avoided, **WILL** result in death or serious injury.



Indicates a potentially hazardous situation which, if not avoided, **COULD** result in death or serious injury.



Indicates a potentially hazardous situation which, if not avoided, **MAY** result in minor or moderate injury. It may also be used to alert against unsafe practices.

NOTICE

This symbol is used to alert the user to useful information about proper operation of the machine.

WARNING

OWNER'S MANUAL. Read and understand this owner's manual **BEFORE** using machine.

TRAINED OPERATORS ONLY. Untrained operators have a higher risk of being hurt or killed. Only allow trained/supervised people to use this power tool. When tool is not being used, disconnect power, and store in out-of-reach location to prevent unauthorized use—especially around children. Make workshop kid proof!

DANGEROUS ENVIRONMENTS. Do not use tools in areas that are wet, cluttered, or have poor lighting. Operating tools in these areas greatly increases risk of accidents and injury.

MENTAL ALERTNESS REQUIRED. Full mental alertness is required for safe operation of power tools. Never operate under the influence of drugs or alcohol, when tired, or when distracted.

DISCONNECT POWER FIRST. Always disconnect tool from power supply **BEFORE** making adjustments, changing tooling, or servicing machine. This prevents an injury risk from unintended startup or contact with live electrical components.

EYE PROTECTION. Always wear ANSI-approved safety glasses or a face shield when operating or observing machinery to reduce the risk of eye injury or blindness from flying particles. Everyday eyeglasses are not approved safety glasses.

ELECTRICAL SAFETY. Tool plug must match outlet. Double-insulated tools have a polarized plug (one blade is wider than the other), which must be plugged into a polarized outlet. Never modify plug. Do not use adapter for grounded tools. Use a ground fault circuit interrupter if operation is unavoidable in damp locations. Avoid touching grounded surfaces when operating tool.

WARNING

WEARING PROPER APPAREL. Do not wear clothing, apparel or jewelry that can become entangled in moving parts. Always tie back or cover long hair. Wear non-slip footwear to avoid accidental slips, which could cause loss of workpiece control. Wear hard hat as needed.

HAZARDOUS DUST. Dust created while using tools may cause cancer, birth defects, or long-term respiratory damage. Be aware of dust hazards associated with each workpiece material, always wear a NIOSH-approved respirator, and connect tool to an appropriate dust collection device to reduce your risk.

HEARING PROTECTION. Always wear hearing protection when operating or observing loud machinery. Extended exposure to this noise without hearing protection can cause permanent hearing loss.

REMOVE ADJUSTING TOOLS. Never leave adjustment tools, chuck keys, wrenches, etc. in or on tool—especially near moving parts. Verify removal before starting!

INTENDED USAGE. Only use tool for its intended purpose. Never modify or alter tool for a purpose not intended by the manufacturer or serious injury or death may result!

AWKWARD POSITIONS. Keep proper footing and balance at all times when operating tool. Do not overreach! Avoid awkward hand positions that make tool control difficult or increase the risk of accidental injury.

SAFE HANDLING. Firmly grip tool. To avoid accidental firing, do not keep finger on switch or trigger while carrying.

SECURING WORKPIECE. When required, use clamps or vises to secure workpiece. A secured workpiece protects hands and frees both of them to operate the tool.

GUARDS & COVERS. Guards and covers reduce accidental contact with moving parts or flying debris. Make sure they are properly installed, undamaged, and working correctly.

CHILDREN & BYSTANDERS. Keep children and bystanders at a safe distance from the work area. Stop using machine if they become a distraction.

FORCING TOOLS. Use the right tool for the job, and do not force it. It will do the job safer and better at the rate for which it was designed.

USE RECOMMENDED ACCESSORIES. Consult this owner's manual or the manufacturer for recommended accessories. Using improper accessories will increase the risk of serious injury.

MAINTAIN WITH CARE. Keep cutting tool edges sharp and clean. Follow all maintenance instructions and lubrication schedules to keep tool in good working condition. A tool that is improperly maintained could malfunction, leading to serious personal injury or death. Only have tool serviced by qualified service-personnel using matching replacement parts.

CHECK DAMAGED PARTS. Regularly inspect tool for any condition that may affect safe operation. Immediately repair or replace damaged or mis-adjusted parts before operating tool.

MAINTAIN POWER CORDS. When disconnecting cord-connected tools from power, grab and pull the plug—NOT the cord. Carrying or pulling the cord may damage wires inside. Do not handle cord/plug with wet hands. Avoid cord damage by keeping it away from heated surfaces, high traffic areas, harsh chemicals, sharp edges, moving parts, and wet/damp locations. Damaged cords increase risk of electrocution.

UNATTENDED OPERATION. Never leave tool running while unattended. Turn tool off and ensure all moving parts completely stop before walking away.

EXPERIENCING DIFFICULTIES. If at any time you experience difficulties performing the intended operation, stop using the machine! Contact our Technical Support at (570) 546-9663.

Additional Safety Instructions for Planers

WARNING

Amputation, serious cuts, entanglement, or death can occur from contact with rotating cutterhead or other moving parts! Flying chips can cause blindness or eye injuries. Workpieces or knives thrown by cutterhead can strike nearby operator or bystanders with deadly force. To reduce the risk of these hazards, operator and bystanders MUST completely heed hazards and warnings below.

KICKBACK. Know how to reduce the risk of kickback and kickback-related injuries. “Kickback” occurs during the operation when the workpiece is ejected from the machine at a high rate of speed. Kickback is commonly caused by poor workpiece selection, unsafe feeding techniques, or improper machine setup/maintenance. Kickback injuries typically occur as follows: (1) operator/bystanders are struck by the workpiece, resulting in impact injuries (i.e., blindness, broken bones, bruises, death); (2) operator’s hands are pulled into blade, resulting in amputation or severe lacerations.

AVOID CONTACT WITH MOVING PARTS. Never remove guards/covers or reach inside the planer during operation or while connected to power. You could be seriously injured if you accidentally touch the spinning cutterhead or get entangled in moving parts. If a workpiece becomes stuck or sawdust removal is necessary, turn planer **OFF** and disconnect power before clearing.

DULL/DAMAGED KNIVES/INSERTS. Only use sharp, undamaged knives/inserts. Dull or damaged knives/inserts increase the risk of kickback.

INSPECTING STOCK. To reduce the risk of kickback injuries or machine damage, thoroughly inspect and prepare the workpiece before cutting. Verify workpiece is free of nails, staples, loose knots or foreign material. Workpieces with minor warping should be jointed first or planed with the cupped side facing the table.

BODY PLACEMENT. Stand to one side of planer during the entire operation to avoid getting hit if kickback occurs.

GRAIN DIRECTION. Planing across the grain is hard on the planer and may cause kickback. Plane in the same direction or at a slight angle with the wood grain.

PLANING CORRECT MATERIAL. Only plane natural wood stock with this planer. DO NOT plane MDF, OSB, plywood, laminates or other synthetic materials that can break up inside the planer and be ejected towards the operator.

LOOKING INSIDE PLANER. Wood chips fly around inside the planer at a high rate of speed during operation. To avoid injury from flying material, DO NOT look inside planer during operation.

CUTTING LIMITATIONS. To reduce the risk of kickback hazards or damage to the machine, do not exceed the maximum depth of cut or minimum board length and thickness found in the **Data Sheet**. Only feed one board at a time.

INFEEED ROLLER CLEARANCE. The infeed roller is designed to pull material into the spinning cutterhead. To reduce the risk of entanglement, keep hands, clothing, jewelry, and long hair away from the infeed roller during operation.

FEED WORKPIECE PROPERLY. To reduce the risk of kickback, never start planer with workpiece touching cutterhead. Allow cutterhead to reach full speed before feeding, and do not change feed speed during cutting operation.

WORKPIECE SUPPORT. To reduce the risk of kickback, always make sure workpiece can move completely across table without rocking or tipping. Use auxiliary support stands for long stock.

SECURE KNIVES/INSERTS. Loose knives or improperly set inserts can become dangerous projectiles or cause machine damage. Always verify knives/inserts are secure and properly adjusted before operation.

SECTION 2: CIRCUIT REQUIREMENTS

220V Single-Phase

The Model G5850Z/G5851Z/G0544 is prewired with a 5 HP single-phase motor. Under normal use, this motor draws approximately 28 amps at 220V. We recommend using a 40 amp circuit. This includes the appropriate wiring and circuit breaker. If frequent circuit failure occurs when using the planer, contact our service department.

The planer must be connected to its own dedicated 40A circuit. It should not share a circuit with any other machine. A standard 2-pole breaker is necessary for use with the planer.

We recommend using a NEMA-style L6-50 plug and outlet similar to that in **Figure 1**. You may also “hard-wire” the planer directly to your panel, provided you place a disconnect near the machine. Check the electrical codes in your area for specifics on wiring requirements.

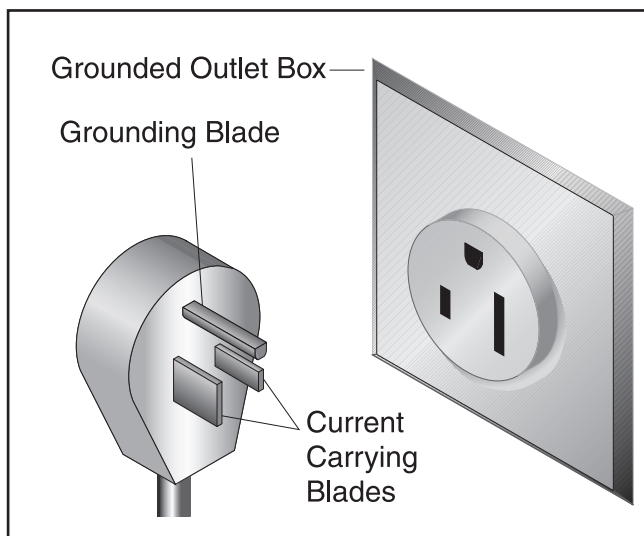

Figure 1. Typical plug configuration for 220V, single-phase operation.



220V 3-Phase

The Model G7213Z Planer is prewired with a 7½ HP 3-phase motor. Under normal use, the motor draws approximately 22 amps at 220V. We recommend using a 25 amp circuit. This includes the appropriate wiring and circuit breaker. If frequent circuit failure occurs when using the planer, contact our service department.

The planer must be connected to its own dedicated 25A circuit. It should not share a circuit with any other machine. A standard 3-pole breaker is necessary for use with 3-phase power.

We recommend using a NEMA-style L15-30 plug and outlet similar to that in **Figure 2**. You may also “hard-wire” the planer directly to your panel, provided you place a disconnect near the machine. Check the electrical codes in your area for specifics on wiring requirements.

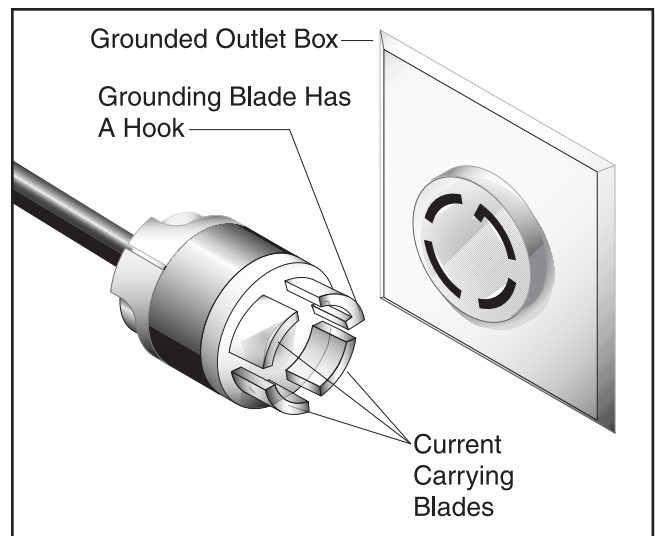

Figure 2. Typical plug configuration for 220V, 3-phase operation.



Grounding

In the event of an electrical short, grounding reduces the risk of electric shock by providing a path of least resistance to disperse electric current. This tool is equipped with an electric cord that has an equipment-grounding conductor which must be properly connected to a grounding plug. The plug must be plugged into a matching outlet that is properly installed and grounded in accordance with all local codes and ordinances.

Improper connections of the electrical-grounding conductor can result in the risk of electric shock. The conductor with green or green and yellow striped insulation is the electrical-grounding conductor. If repair or replacement of the electric cord or plug is necessary, do not connect the equipment grounding conductor to a live terminal.

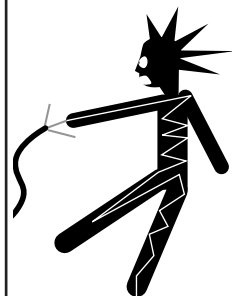
	<p>⚠️ WARNING This equipment must be grounded. Verify that any existing electrical outlet and circuit you intend to plug into is actually grounded. Under no circumstances should the grounding pin from any three-pronged plug be removed. Serious injury may occur.</p>
--	--



Extension Cords

We do not recommend the use of extension cords on 220V equipment. It is much better to arrange the p⁻⁶⁻ of your equipment and the installed wiring to eliminate the need for extension cords. Should it be necessary to use an extension make sure the cord is rated Hard Service (grade S) or better. Refer to the chart in *Section 1: Safety* to determine the minimum gauge for the extension cord. The extension cord must also contain a ground wire and plug pin. Always repair or replace extension cords when they become worn or damaged.



SECTION 3: GENERAL INFORMATION

Commentary

Grizzly Industrial, Inc. is proud to offer the Professional Series Planers. These planers are part of Grizzly's growing family of fine woodworking and metalworking machinery. When used according to the guidelines stated in this manual, you can expect years of trouble-free, enjoyable operation.

The Models G0544, G5850Z, G5851Z & G7213 Professional Series Planers are the same machine with the exception of motor size, electrical phase and cutterhead differences. Please refer to the chart below to distinguish planer differences.

These planers are intended for heavy-duty professional use and are capable of operating at 5200 RPM with a 17-26 FPM variable feed rate.

We are also pleased to provide this manual with the Models G0444, G5850Z, G5851Z & G7213 Professional Series Planers. It was written to guide you through assembly, review safety considerations, and cover general operating procedures. If you have any criticisms that you feel we should address in our next printing, please write to us at the address below:

Grizzly Industrial, Inc.
% Technical Documentation
P.O. Box 2069
Bellingham, WA 98227

Most important, we stand behind our machines. We have an excellent Service Department at your disposal should the need arise. If you have any service questions or parts requests, please call or write to us at the location listed below.

Grizzly Industrial, Inc.
1203 Lycoming Mall Circle
Muncy, PA 17756
Phone:(570) 546-9663
Fax:(800) 438-5901
E-Mail: techsupport@grizzly.com
Web Site: <http://www.grizzly.com>

The specifications, drawings, and photographs illustrated in this manual represent the Professional Series Planers as supplied when the manual was prepared. However, owing to Grizzly's policy of continuous improvement, changes may be made at any time with no obligation on the part of Grizzly. Whenever possible, though, we send manual updates to all owners of a particular tool or machine. Should you receive one, we urge you to insert the new information with the old and keep it for reference.

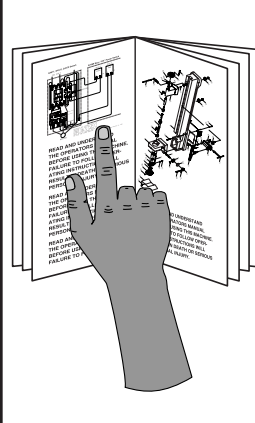

!WARNING

Read the manual before assembly and operation. Become familiar with the machine and its operation before beginning any work. Serious personal injury may result if safety or operational information is not understood or followed.

Description	G0544	G5850Z	G5851Z	G7213Z
Motor	5 HP	5 HP	5 HP	7½ HP
Phase	1-Phase	1-Phase	1-Phase	3-Phase
Size	20"	20"	24"	24"
Cutterhead	Spiral Cutterhead w/ Indexable Inserts	4-Knife	4-Knife	4-Knife

Unpacking

The planer base unit and the hardware are shipped from the manufacturer in a carefully packed carton. If you discover the machine is damaged after you have signed for delivery, and the truck and driver are gone, you will need to file a freight claim with the carrier. Save the containers and all packing materials for possible inspection by the carrier or its agent. Without the packing materials, filing a freight claim can be difficult. *If you need assistance determining whether you need to file a freight claim, or with the procedure to file one, please contact our Customer Service.*

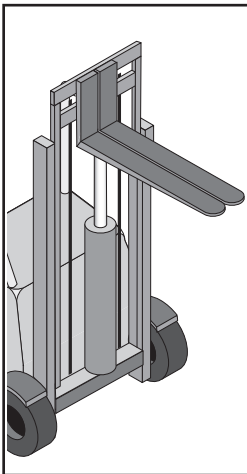

!WARNING

These planers are heavy machines—1030 lbs. shipping weight. DO NOT over-exert yourself while unpacking or moving your machine. Use power equipment. Serious personal injury may occur if safe moving methods are not followed.

When you are completely satisfied with the condition of your shipment, you should inventory its parts.



Piece Inventory

After all the parts have been removed from the carton, you should have:

Part	Qty
• Planer Unit	1
• Dust Hood	1
• Adjustment Handle	1
• Combo Wrench 10/12mm	1
• Combo Wrench 12/14mm	1
• Combo Wrench 17/19mm	1
• Hex Wrench 4mm	1
• Knife Setting Jig	1

In the event that any nonproprietary parts are missing (e.g. a nut or a washer), we would be glad to replace them, or for the sake of expediency, replacements can be obtained at your local hardware store.

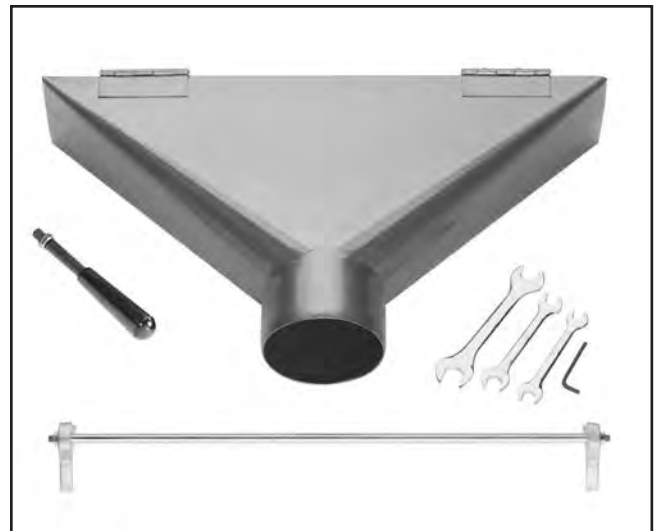

Figure 3. Loose Parts.



Hardware Recognition Chart

Use this chart to match up hardware pieces during the assembly process!

MEASURE BOLT DIAMETER BY PLACING INSIDE CIRCLE

- #10
- 1/4"
- 5/16"
- 3/8"
- 7/16"
- 1/2"

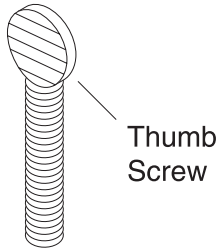

Thumb Screw

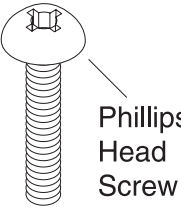

Phillips Head Screw

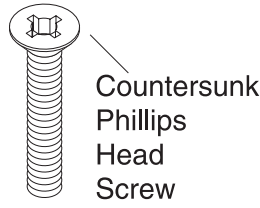

Countersunk Phillips Head Screw

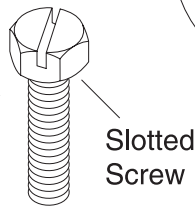

Slotted Screw

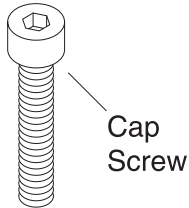

Cap Screw

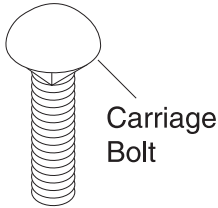

Carriage Bolt

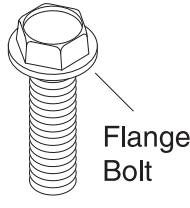

Flange Bolt

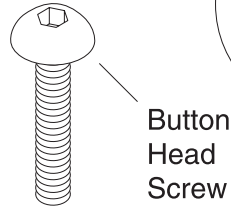

Button Head Screw



Setscrew

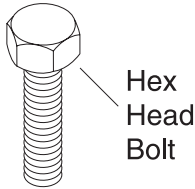

Hex Head Bolt

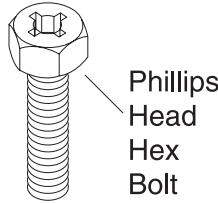

Phillips Head Hex Bolt

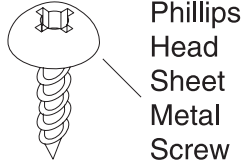

Phillips Head Sheet Metal Screw

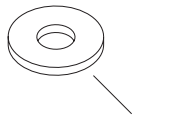
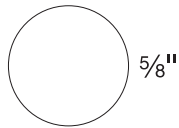

Washer

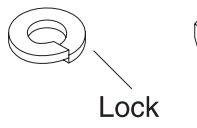

Lock Washer

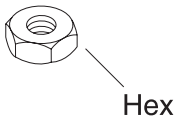

Hex Nut

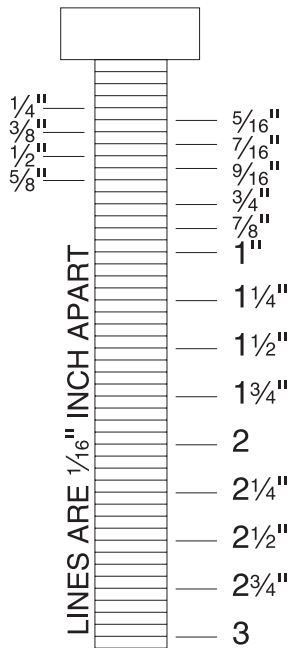
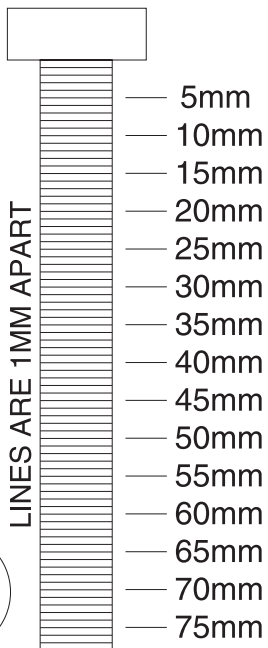

WASHERS ARE MEASURED BY THE INSIDE DIAMETER

WASHER DIAMETER 5/8"

WASHER DIAMETER 9/16"

WASHER DIAMETER 1/2"

WASHER DIAMETER 7/16"

WASHER DIAMETER 12mm

WASHER DIAMETER 10mm

WASHER DIAMETER 8mm

WASHER DIAMETER 4mm

WASHER DIAMETER 6mm

WASHER DIAMETER 3/8"

WASHER DIAMETER 5/16"

WASHER DIAMETER 1/4"

WASHER DIAMETER #10

Clean Up

The unpainted surfaces are coated with a waxy oil to protect them from corrosion during shipment. Remove this protective coating with a solvent cleaner or citrus-based degreaser such as Grizzly's G7895 Degreaser. To clean thoroughly, some parts may need to be removed. **For optimum performance from your machine, make sure you clean all moving parts or sliding contact surfaces that are coated.** Avoid chlorine-based solvents as they may damage painted surfaces should they come in contact. Always follow the manufacturer's instructions when using any type of cleaning product.

	<p>⚠ WARNING Do not use gasoline or other petroleum-based solvents to clean with. They have low flash points which make them extremely flammable. A risk of explosion and burning exists if these products are used.</p>
--	---

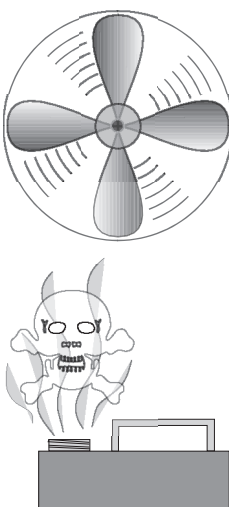
	<p>⚠ CAUTION Many of the solvents commonly used to clean machinery can be toxic when inhaled or ingested. Always work in well-ventilated areas far from potential ignition sources when dealing with solvents. Use care when disposing of waste rags and towels to be sure they do not create fire or environmental hazards.</p>
---	---

Site Considerations

FLOOR LOAD

Your Professional Series Planer represents a very large weight load in a moderate sized footprint. Most commercial shop floors will be adequate for the 1030 lb. weight of the planer. Some floors may require additional support. Contact an architect or structural engineer if you have any question about the ability of your floor to handle the weight.

WORKING CLEARANCES

Working clearances can be thought of as the distances between machines and obstacles that allow safe operation of every machine without limitation. Consider existing and anticipated machine needs, size of material to be processed through each machine, and space for auxiliary stands and/or work tables. Also consider the relative position of each machine to one another for efficient material handling. Be sure to allow yourself sufficient room to safely run your machines in any foreseeable operation.

LIGHTING AND OUTLETS

Lighting should be bright enough to eliminate shadow and prevent eye strain. Electrical circuits should be dedicated or large enough to handle combined motor amp loads. Outlets should be located near each machine so power or extension cords are not obstructing high-traffic areas. Be sure to observe local electrical codes for proper installation of new lighting, outlets or circuits.

	<p>⚠ CAUTION Make your shop "child safe." Ensure that your workplace is inaccessible to children by closing and locking all entrances when you are away. Never allow visitors in your shop when assembling, adjusting or operating equipment.</p>
--	--



SECTION 4: ASSEMBLY

Beginning Assembly

Most of your Professional Series Planer has been assembled at the factory, but some parts must be assembled or installed after delivery. We have organized the assembly process into steps. Please follow along in the order presented in this section.

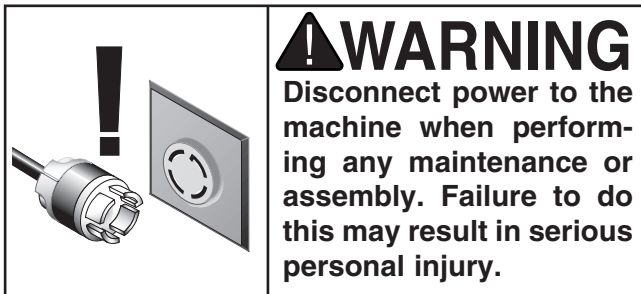
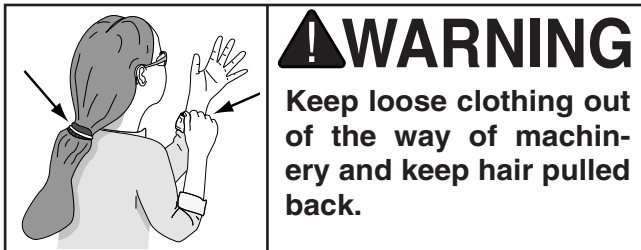

Dust Hood

A dust hood with a 5" dust port comes with the planer for dust collection purposes. Install the dust hood as shown in **Figure 4** with the hex bolts already mounted to the top of the planer. **Do not use the dust hood if dust collection is not available.**



Figure 4. Dust hood installed.



Adjustment Handle

An adjustment handle has been provided with the planer for adequate leverage when adjusting the bed rollers.

To install the adjustment handle:

1. Screw the adjustment handle into the hub that controls bed roller adjustments.
2. Tighten down the handle lock nut to the hub to keep the handle secure.



SECTION 5: ADJUSTMENTS

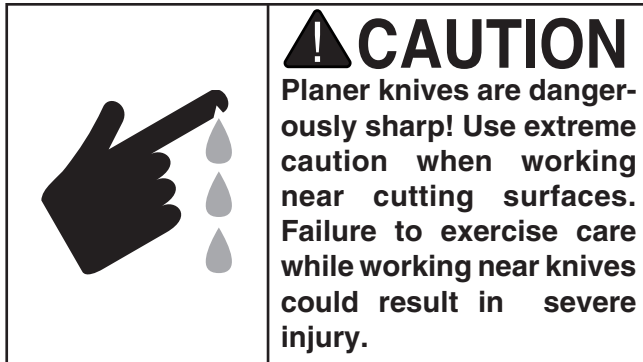

Adjustment Controls

Figures 5 and 6 point out the primary controls and components that will be used during the adjustment process. Take a few minutes to familiarize yourself with these.

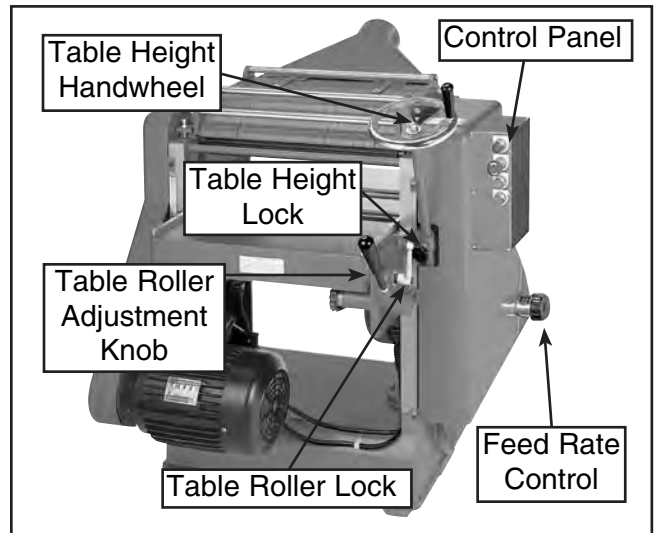

Figure 5. Planer controls.

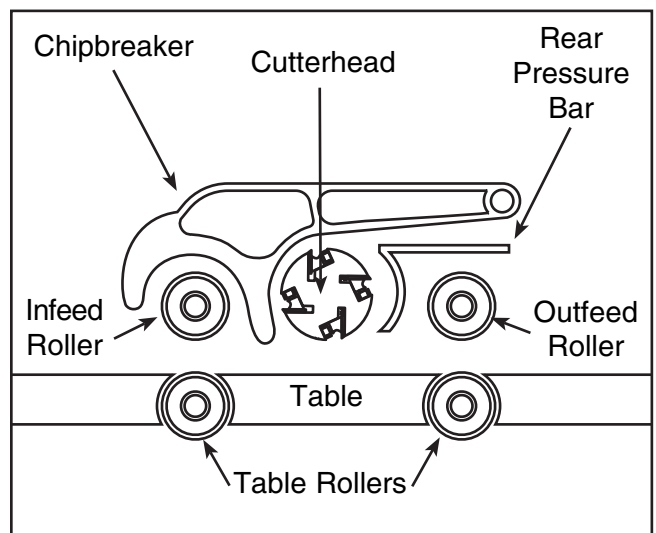

Figure 6. Planer components.



Cutterhead Knives

The G5850Z, G5851Z & G7213 Professional Series Planers feature 4-knife cutterheads. These knives must be periodically replaced or adjusted. To prolong the sharpness of the knife edges, adjustments should be within .002" from one side to the other. Improperly adjusted knives can unbalance the cutterhead and shorten the bearing life, as well as produce substandard planing results.

To be safe, always test the planer with a scrap piece of wood before using expensive stock.

To inspect the knife set:

1. **Make sure the planer is unplugged!**
2. Open the top cover to gain access to the cutterhead. Remove the pulley cover from the left side of the machine (this will allow you to rotate the cutterhead without putting your hands near the blades).
3. The knife setting jig has special grooves cut into it that fit the knife edge profile. One end of the jig should be fixed in place and the other end should be loose enough to swivel and match the fixed end.
4. Place the jig on the cutterhead so the grooves catch on the knife edge, keeping the jig in place. If the knife is adjusted right, the feet should touch the cutterhead body on both sides of the knife, and the knife should fit in the special grooves in the jig. Repeat this inspection for the other three knives.

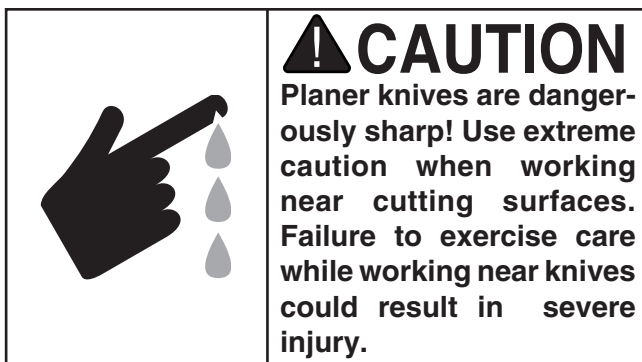

To adjust the knife set:

1. Before beginning, make sure you have followed **steps 1-4** from the previous knife inspection instructions! See **Figure 7** to familiarize yourself with the components of the cutterhead.
2. Loosen all the gib bolts (work on only one knife at a time). Wear heavy leather gloves or place a rag over the exposed knife to protect your hands if the wrench slips while loosening the gib bolts.
3. Using the holes in the cutterhead body for access, insert a hex wrench into the jack screws as shown in **Figure 8**. These screws will allow you to lower/raise the knife.

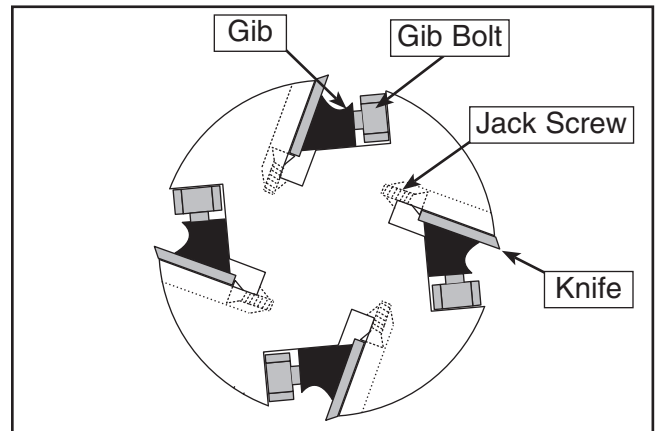

Figure 7. Parts of the cutterhead.



Figure 8. Adjusting knife height.

4. Turn the jack screws with the hex wrench to raise the knife so it barely touches the jig. Perform this adjustment on both sides.
5. Snug, but do not completely tighten, one gib bolt on each side then double check to make sure that the knife did not move. **The back edge of beveled knife edge should never be set below the cutterhead body.**
6. Repeat **steps 2-6** on the other three knives.
7. Now tighten the two center bolts of each of the four knives. Tighten the next two bolts from the center of each knife, and continue tightening the rest of the gib bolts in this manner until all bolts on all four knives have been tightened.

Tightening the gib bolts evenly, two at a time, each knife at a time, will prevent distortion of the cutterhead from over-torquing the gib bolts.

8. Replace all of the removed planer parts and adjust the pressure bar before operating the planer (pressure bar adjustment is covered later in this manual).

Aftermarket Knife Setting Jigs

To ease the knife adjustment process, consider using Planer Pals[®] shown in **Figure 9** and available in the current Grizzly catalog. Using magnets, a pair of these devices will automatically hold the knife blades within .001" of each other, thereby allowing you to quickly and accurately lock the knife in place.



Figure 9. Planer Pal[®].

	<p>! WARNING Disconnect power to the machine when performing any adjustments or maintenance. Failure to do this may result in serious personal injury.</p>
--	---



Table

To obtain accurate results with your Professional Series Planer, the table must be parallel with the cutterhead. We strongly suggest using a Rotacator® for making adjustments to your planer. This tool is well worth the money, because it provides accuracy to .001" and will save you hours of frustration. Check with the current Grizzly catalog for details.

As an alternative to using a Rotacator®, construct a block of scrap wood to aid in checking the table. The wood block should be rectangular and should have one side that sits flat on the table. Make the block tall enough to leave adequate working room between the table and the cutterhead, but thin enough to fit between the chip deflector and pressure bar.

To check the table with a Rotacator®:

1. **Make sure the planer is unplugged!**
2. Set the Rotacator® dial to .000". Place the Rotacator® under the cutterhead on one end. Turn the cutterhead so the plunger on the Rotacator® will contact the cutterhead body as shown in **Figure 10**. Raise the table up enough for the cutterhead to get a reading on the dial.

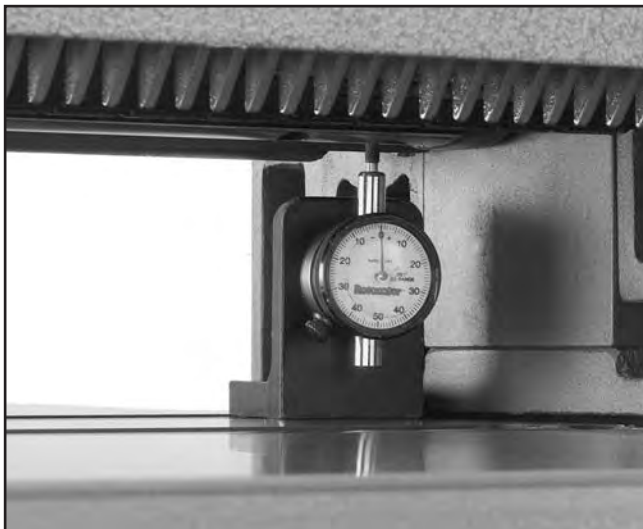

Figure 10. Rotacator measuring cutterhead/table for being parallel to each other.

3. Move the Rotacator® back and forth to find bottom dead center on the cutterhead (you will reach bottom dead center when you have the highest reading on the Rotacator®.)
4. Now raise the table up so the Rotacator® reads exactly .050", and set the dial to .000".
5. Move the Rotacator® to the other side of the cutterhead and find bottom dead center. If the difference in either direction of the dial is more than .002", then the table should be adjusted.

To check the table with the block of wood:

1. **Make sure the planer is unplugged!**
2. Place the block of wood on the table, underneath the cutterhead. Position the block on the left side of the cutterhead as illustrated in **Figure 11**.
3. Raise the table up until the top of the block lightly contacts the bottom of the cutterhead drum.
4. Without moving the table position, slide the block over to the other side.
5. If the block will not fit under the cutterhead or if the gap between the block and the cutterhead exceeds .002" (use a feeler gauge to measure this), the table must be adjusted.

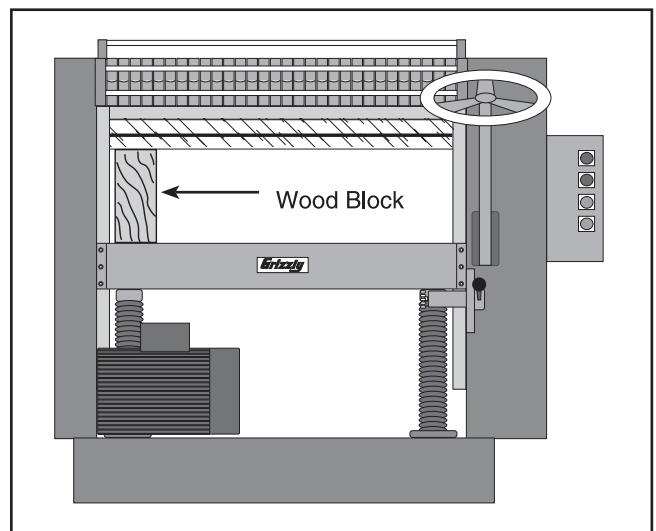

Figure 11. Using a wood block to determine if table is parallel with cutterhead body.

To adjust the table with the Rotacator®:

1. Make sure the planer is unplugged!
2. Set the Rotacator® dial to .000". Place the Rotacator® under the cutterhead on the right-hand side (facing front).
3. Turn the cutterhead so the plunger on the Rotacator® will contact the cutterhead body. Raise the table up enough for the cutterhead to get a reading on the dial.
4. Move the Rotacator® back and forth to find bottom dead center on the cutterhead. (You will reach bottom dead center when you have the highest reading on the Rotacator®.)
5. Adjust the table with the height handwheel to make the dial on the Rotacator® read .050", then set the dial to .000". Move the Rotacator® over to the far left end of the cutterhead and find bottom dead center.
6. Locate the two columns underneath the table. These are covered in flexible rubber sleeves. The column on the left hand side of the machine (from the front) has a clamping collar where it mounts to the table. Loosen the pressure on this clamp and loosen the two mounting bolts that secure the column to the table.
7. Pull the rubber sleeve down to expose the adjustment collar shown in **Figure 11**. Turning this collar counter-clockwise will lower the left side of the table; turning this collar clockwise will raise the left side of the table.
8. Turn the adjustment collar as necessary to make the left side read .050" on the Rotacator dial. Double check the table-to-cutterhead measurement on the right end to make sure it did not move. Adjust as necessary. The Rotacator® will allow you to easily get each end within .002" of each other.
9. When each end is adjusted properly, tighten all of the nuts at the table mount and clamp. Double check the table-to-cutterhead measurement to make sure the table did not move.

To adjust the table with the wood block:

1. Make sure the planer is unplugged!
2. Place the wood block on the far side of the table where the tightest gap exists between the table and the cutterhead.
3. Raise the table so the cutterhead barely touches the wood block. Slide the wood block to the other end of the table.
4. Locate the two columns underneath the table. These are covered in flexible rubber sleeves. The column on the left hand side of the machine (from the front) has a clamping collar where it mounts to the table. Loosen the pressure on this clamp and loosen the two mounting bolts that secure the column to the table.
5. Pull the rubber sleeve down to expose the adjustment collar shown in **Figure 12**. Turning this collar counter-clockwise will lower the left side of the table; turning this collar clockwise will raise the left side of the table.



Figure 12. Column adjustment flange underneath table.

6. Adjust the table as necessary until each side is equal to or less than .003" from each other. Use a feeler gauge to check the tolerances.
7. Tighten all of the nuts at the table mount and clamp. Double check the table-to-cutterhead measurement to make sure the table did not move.
8. Move the rubber sleeve back to its original position. The rubber sleeves must cover the lifting column to keep fine sawdust from building up in the gear grease.

Table Gibs

The front of the table is equipped with gibs (**see Figure 13**) to prevent the table from rocking back and forth during operation.

These gibs should be adjusted individually so they are lightly contacting all four surfaces. The gibs should be tight enough to prevent rocking or movement of the table during operation.

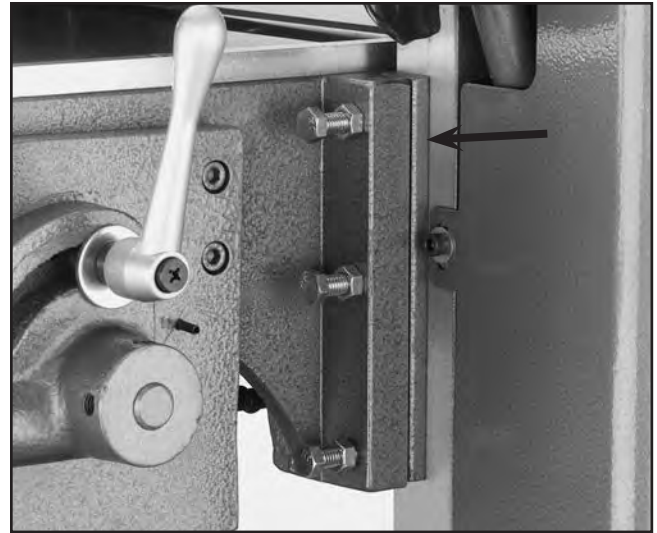

Figure 13. Table gib.



Feed Rollers, Pressure Bar & Chip Breaker

For most planing applications, the feed rollers, pressure bar, and chipbreaker should be approximately .040" below the knife edge at bottom dead center. **All of these components are factory set. Adjusting them can be a difficult process and is not recommended when the machine is new, unless you are getting unsatisfactory performance.**

Although not required, we recommend using a Rotacator® for the following setup. Check with the current Grizzly catalog for details. Also, remove the cover on the left-hand side of the machine so you can advance the cutterhead with the pulley.

To set the feed rollers, pressure bar, and chipbreaker with a Rotacator®:

1. **Make sure the planer is unplugged** and the knives are adjusted properly.
2. Place the Rotacator® on the table, underneath the cutterhead. Place the Rotacator® plunger against the body of the cutterhead. Move the Rotacator® back and forth to find bottom dead center.
3. Rotate the cutterhead so a knife edge will push the plunger down as far as it will go before leaving bottom dead center. Set the dial to .000" and lock in place.
4. Move the Rotacator® directly under one side of the feed roller and set the plunger on a bottom dead center edge. With the adjustment screws shown in **Figure 14**, move the feed roller down .040". (The feed roller has two .040" indications on the dial. Do not skip the first one as the needle moves clockwise or your reading will actually be .060".)
5. Repeat **step 4** on each end of each feed roller. Double check for accuracy, then lock the check nuts in place. While doing this, watch the Rotacator® dial to make sure the height setting does not change.

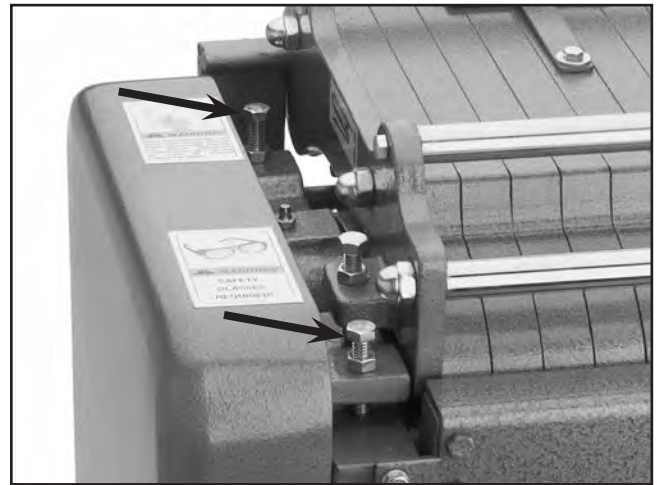

Figure 14. Feed roller adjustment controls

6. Adjust the pressure bar and chip breaker using the same procedure as with the feed rollers. The adjustment controls for each are shown in **Figures 15 and 16**.

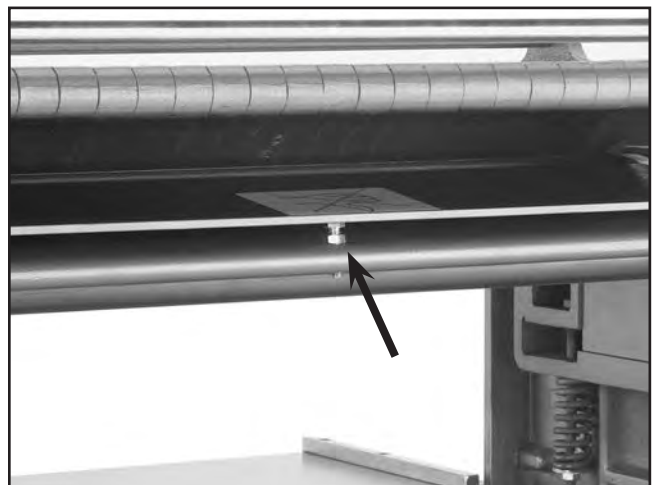

Figure 15. Pressure bar adjustment controls.

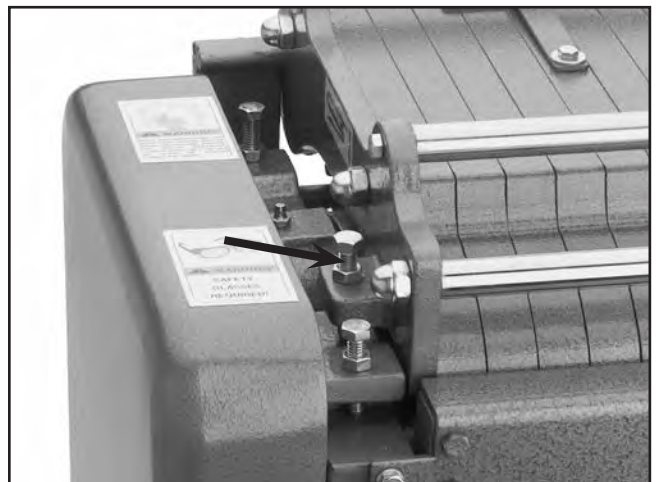

Figure 16. Chip breaker adjustment controls.

To set the feed rollers and pressure bar using hardwood blocks:

1. **Make sure the machine is unplugged** and the knives have been set up properly!
2. Obtain a milled piece of hardwood that is within .002" from one side to another in thickness. Rip this piece down the middle. (Two separate boards may also be used if they are within .002" of each other in thickness.)
3. Lower the bed rollers below the surface of the table.
4. Place the boards on each side of the table as shown in **Figure 17**, so each board spans from the front of the table to the back.

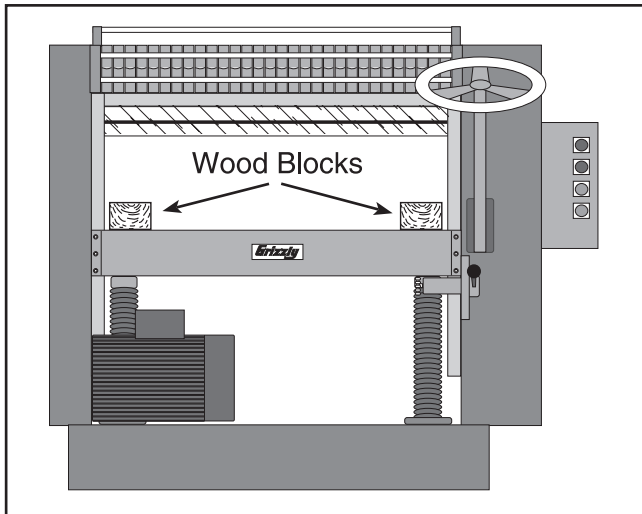

Figure 17. Board position on table.

5. Open the top cover. Loosen the feed roller adjustment screws and turn the adjustment bolts on each end to raise the feed roller up approximately 1/2" (enough to be above the bottom-dead-center horizontal plane of the cutterhead knife/insert).
6. Place a sheet of newspaper on each wood block. (This will act as a type of feeler gauge while keeping your hands away from the sharp knife edges.) Raise the table close to the knife/insert edge. Continue raising the table while constantly checking for resistance on the newspaper. When you get a medium drag between the knife edge and the wood block, stop raising the table and remove the newspaper.

Because the table position is nearly even with the knife edge, it will now be your reference point from which to make the other adjustments.

7. Lower the feed rollers so they rest on the wood blocks. Back the adjustment bolts out another 1/8" (approximately).
8. Notice the position of your pointer on the table height scale (shown in **Figure 18**). Lower the table approximately 1mm on this scale (this is very close to .040").

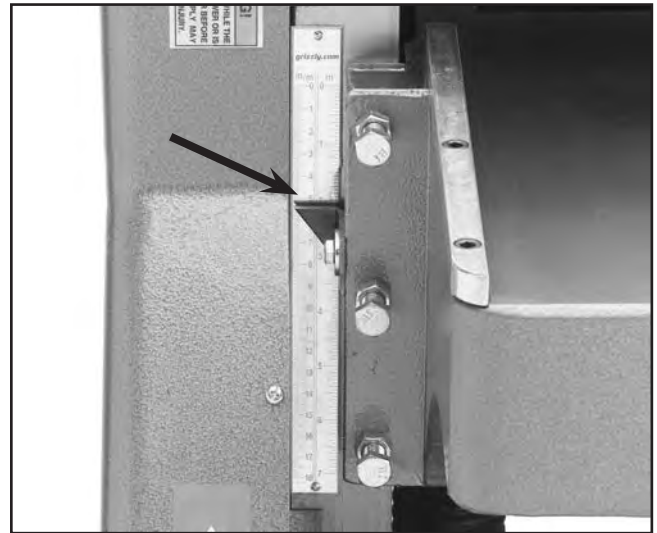

Figure 18. Table height scale and pointer.

9. Tighten the check nuts while holding the adjustment bolts in place so they do not move.
10. Adjust the pressure bar stop bolt so the pressure bar rests on the wood blocks.
11. Tighten the check nut to keep the pressure bar stop bolt in place.

The feed rollers and pressure bar should now be approximately .040" below the knife edge.

NOTICE

The settings described here are to be used as a guide and are not absolute. Raising or lowering feed rollers/pressure bar for different types of stock may increase the quality of your finished results.



Table Rollers

After completing the table adjustments, set the table rollers. The height of the table rollers will vary, depending on the type of material you intend to plane. When planing rough stock, you will need to set the rollers high to keep the lumber from dragging along the table. Milled lumber should be planed with the rollers set lower.

To adjust the table rollers:

1. Loosen the lock on the adjustment lever shown in **Figure 18**. Moving the lever up will raise the table rollers up.

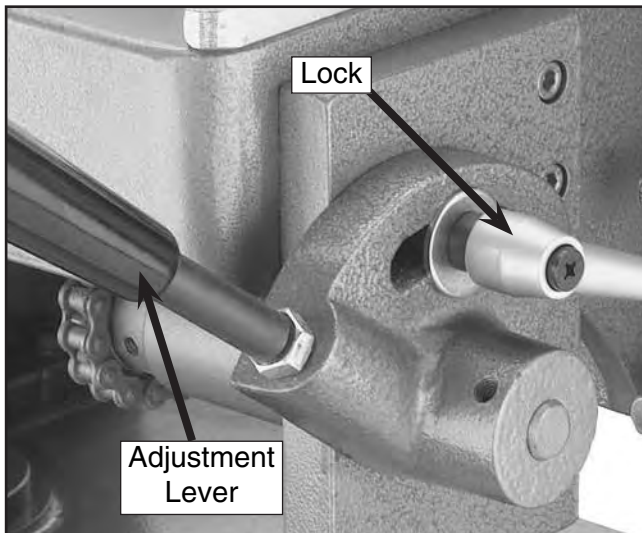

Figure 18. Roller height adjustment controls.

2. Determine the appropriate height for the type of stock you are using. The ideal tolerance for the height of the bed rollers is between .002"-.016". If the bed rollers are too high, snipe or chipping may occur at the ends of the workpiece. Only use the higher settings for rough cut lumber. If you are unsure about which height to use, experiment on scrap lumber through trial and error. Always start at smaller tolerances and work up.
3. Place a high quality straightedge across the length of the table. Raise and lock the table rollers and use a feeler gauge to measure the distance between the bottom of the straightedge and the table.

If you have a Rotacator[®], place it on the table with the plunger against the table surface. Set the dial to 0. Move it back and forth over the table roller to find top dead center.



Figure 19. Rotacator[®] on bed rollers.

4. Adjust the roller height until it is satisfactory for your particular situation.

The first time you set your table rollers, and periodically after that, check the roller height at both ends of the table. If one roller is more than .016" different in height than the other roller, then the roller adjustment equipment needs to be corrected. The adjustment bolts shown in **Figure 20** allow you to move one end of the rollers to correct this situation.

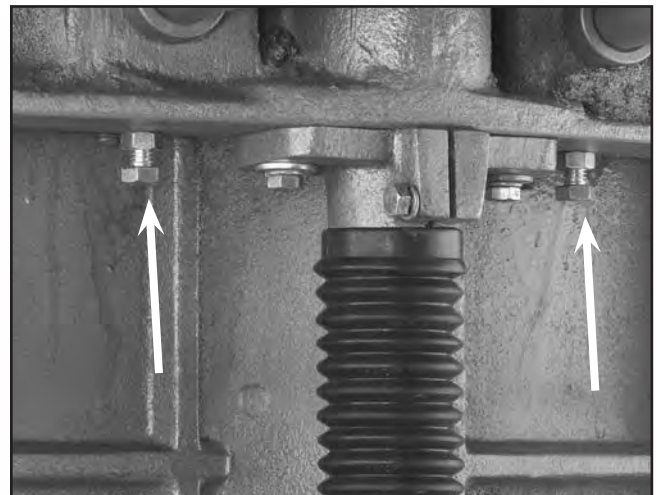

Figure 20. Roller adjustment bolts.



Feed Roller Tension

The spring tension on the feed rollers is factory set and should require no initial adjustments, unless needed for a special type of stock. If a situation develops where the workpiece does not feed straight, adjustments to one roller may be necessary. Usually if the board is moving more to one side, that side needs less pressure.

Open the top cover of the planer and locate the adjustment bolts attached to springs (shown in **Figure 21**). Loosen the lock nuts and turn the bolts clockwise to lower the feed rollers and counter-clockwise to raise the feed rollers.

In general, rough stock or deeper cuts require more feed rate pressure (spring tension). Shallow cuts need less feed rate pressure. Too much pressure increases snipe. Often the best way to find a setting that is right for your application is through trial and error.

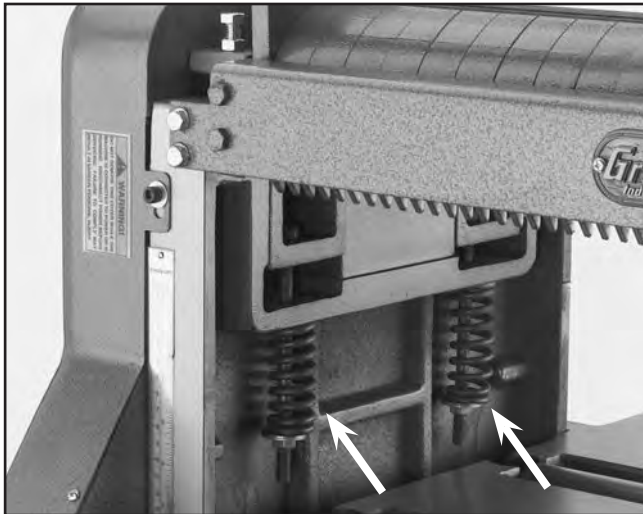

Figure 21. Feed roller spring tension bolts.



Test Run

Once assembly is complete and adjustments are done to your satisfaction, you are ready to start the machine.

Turn on the power supply at the main panel. Press the *START* button. Make sure that your finger is poised on the *STOP* button, just in case there is a problem. The planer should run smoothly with little or no vibration or rubbing noises. Strange or unnatural noises should be investigated and corrected before operating the machine further.

Run the planer for a short time to ensure that the moving parts are working properly with no excessive vibration. If any problem develops, correct it before attempting to use the machine.

If you cannot locate the source of unusual noises or cannot fix any problems that arise, immediately contact our service department for help.



	<p>!WARNING</p> <p>Read the entire manual before making any cuts with your planer. Serious personal injury may result if safety or operational information is not understood or followed.</p>
--	--

SECTION 6: OPERATIONS

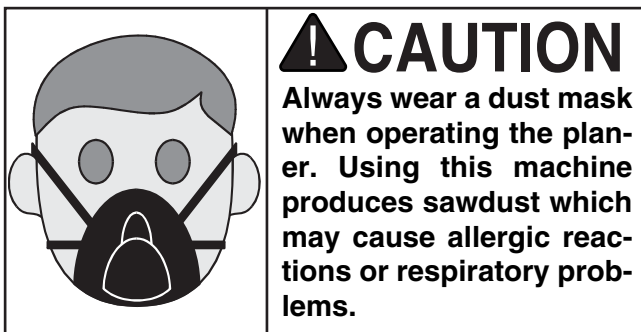
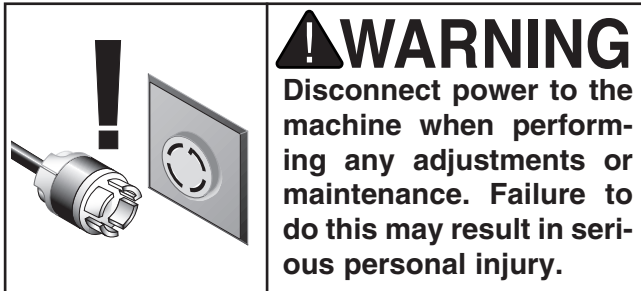

NOTICE

The following section is designed to give instructions on the basic operations of this planer. However, it is in no way comprehensive of every planer application. WE STRONGLY RECOMMEND that you read books, trade magazines, or get formal training to maximize the potential of your planer.

Operation Controls

Familiarize yourself with the planer controls before turning the machine *ON*. See **Figures 22 and 23**.

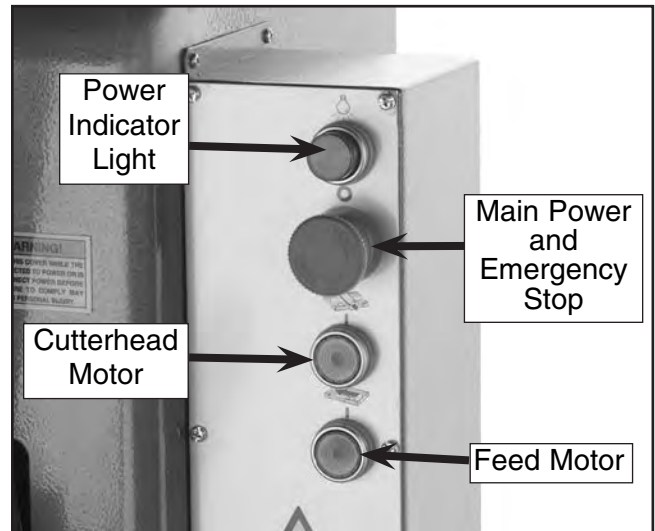

Figure 22. Control panel.

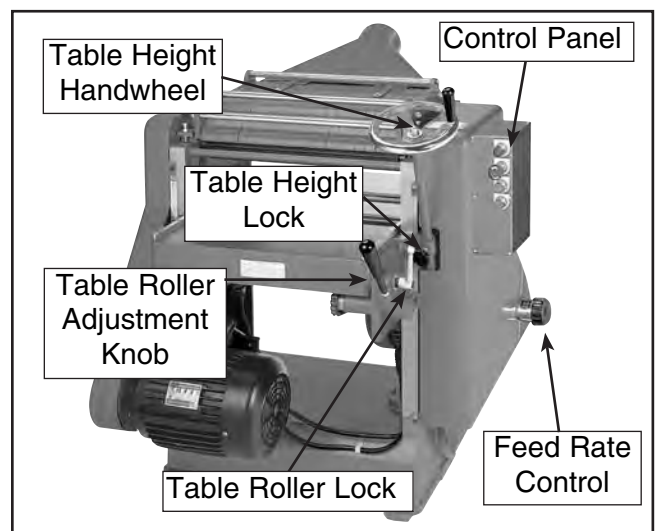

Figure 23. Planer controls.



Feed Rate

The Professional Series Planers offer variable feed rates between 17 and 26 FPM. Turning the feed control knob (**Figure 24**) clockwise will increase the feed rate and turning counter-clockwise will decrease the feed rate.

In order to assure maximum belt life, only adjust the feed rate while the feed motor is moving!

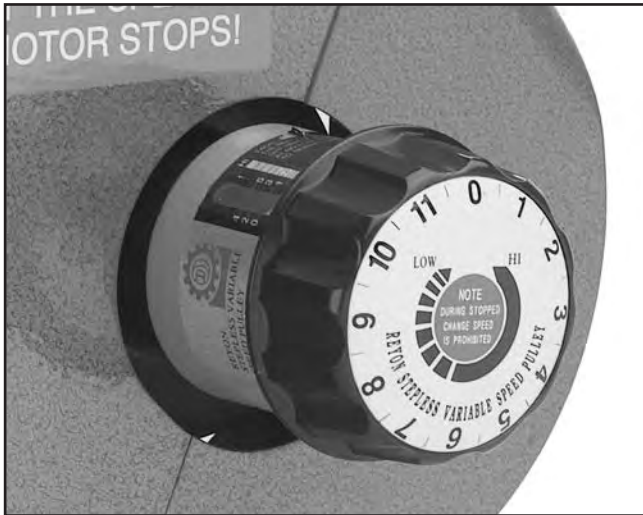

Figure 24. Variable speed control knob.



Operational Tips

- Inspect lumber for defects, warping, cupping, twisting, and for foreign objects (nails, staples, imbedded gravel, etc.). If you have any question about the quality of your lumber, do not use it. Remember, wood stacked on a concrete floor can have small pieces of stone or concrete pressed into its surface.
- Use the full width of the planer. Alternate between the left, the right and the middle when feeding lumber into the planer. Your knives will remain sharp much longer.
- Scrape all glue off of joined boards before planing.
- Plane **ONLY** natural wood fiber. No wood composites.
- Surface wood with the grain. **NEVER** feed end-cut or end-grained lumber into your planer.
- Do not use boards with knots, splits, cross-grain or other obvious blemishes or defects. They can damage the machine and they pose the possibility of operator injury.
- Keep your work area clear.
- Avoid planing wood with a high water content. Wood with more than 20% moisture content or wood exposed to rain or snow will plane poorly and cause excessive wear to the knives and the motor. Excess moisture can also hasten rust and corrosion.
- During operation, always use the table height lock knob for consistent and accurate results.
- Always true any cupped or warped stock on a jointer before planing.



Wood Characteristics

The species of wood, as well as condition, will affect planing ability—the harder the wood, the more difficult it will be to plane. We have included a list of wood characteristics you may encounter when planing. The following descriptions of defects will give you some possible answers to problems you may encounter while planing different materials.

Chipped Grain (Tear Out) — Usually a result of cutting against the grain, or planing wood with knots or excessive amount of crossgrain. Chipped grain can also be caused by dull knives or a misaligned chipbreaker. Often, chipped grain can be avoided by slowing down the feed rate and by taking shallow cuts. If those options do not work, inspect your lumber and determine if its grain pattern is causing the problem. If the wood does not show substantial crossgrain, unplug the planer and inspect your knives for sharpness and inspect the chipbreaker for proper alignment.

Fuzzy Grain (Raised Grain) — Usually caused by surfacing lumber with too high of a moisture content. Sometimes fuzzy grain is a characteristic of wood such as basswood. Fuzzy grain can also be caused by dull knives or an incorrect grinding bevel. Check with a moisture meter. If moisture is greater than 20%, sticker the wood and allow it to dry. Otherwise, inspect the knife condition.

Glossy Surface — Usually caused by dull knives taking shallow cuts at a slow feed speed. Surface gloss will usually be accompanied by overheating. Often lumber will be scorched, and eventually, damage to knives will occur. If knives are sharp upon inspection, increase feed speed or cutting depth.

Snipe — Occurs when board ends have more material removed than the rest of the board. Usually caused when one or both of the bed rollers are set too high. Can also be caused by the chipbreaker or pressure bar being set too high. However, a small amount of snipe is often inevitable.

Snipe can be minimized by proper adjustment of

the planer components, but complete removal of snipe is unlikely. More likely, you will be able to reduce it to a tolerance of .002". If snipe under that level is a problem, consider planing lumber longer than your intended work length and cut off the excess after planing is completed, or consider sanding.

Uneven Knife Marks — Uneven knife marks can occur when the chipbreaker is set too high. Inspect cutterhead bearings if re-adjustment of the chipbreaker fails to remedy the situation.

Chatter Marks — Usually caused by incorrect chipbreaker and pressure bar setting heights. Chatter marks can also be caused by running a narrow wood piece through the planer at either the right or left end of the cutterhead. Chatter, like uneven knife marks, will show in the form of a “washboard” look. Chatter marks are more likely to be inconsistent in appearance than uneven knife marks.

Wavy Surface — Caused by poor knife height adjustment, wavy surface appears when one knife is taking deeper cuts than the rest of the knives. Remedy by resetting the knives to a tolerance within .001" from one end to the other.

Pitch & Glue Build-Up — Glue and resin build-up on the rollers and cutterhead will cause overheating by decreasing cutting sharpness while increasing drag in the feed mechanism. The result can include scorched lumber as well as uneven knife marks and chatter.

Chip Marks — Occur when chips are not properly expelled from the cutterhead. The knives catch the chips and drag them across the lumber being planed. Chips tend to be random and non-uniform (compared to chipped grain). This problem can be caused by exhaust blockage or too much room between the cutterhead and the chip deflector. Inspect the chip deflector and re-adjust the spring tension. Also, using a dust collection system with the planer can help reduce chip marks.



SECTION 7: MAINTENANCE

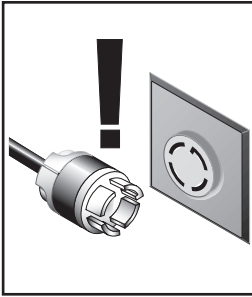

⚠ WARNING
Disconnect power to the machine when performing any adjustments or maintenance. Failure to do this may result in serious personal injury.

General

Regular periodic maintenance on your Professional Series Planer ensures its optimum performance. Make a habit of inspecting your planer each time you use it.

Check for the following conditions and repair or replace when necessary.

- Loose mounting bolts.
- Worn switch.
- Worn or damaged cords and plugs.
- Damaged V-belt.
- Any other condition that could hamper the safe operation of this machine.



Cleaning

Regularly blow out cabinet, feed rollers, chip breakers and cutterhead with compressed air (always wear a dust mask when doing this) and keep the dust port clear.



Table

The table and other non-painted surfaces on the Professional Series Planer should be protected against rust and pitting. Wiping the table clean after every use ensures that wood dust is not allowed to trap moisture against bare metal surfaces.

Tables can be kept rust-free with regular applications of products like Boeshield® T-9. For long term storage you may want to consider products like Kleen Bore's Rust Guardit™.



Lubrication

The Professional Series Planers have four lubrication points that need to be lubricated according to planer usage. Always lubricate more often under dusty/dirty conditions. As a general rule, lubricate as follows:

1. **Cutterhead Grease Fittings** — Once a week for heavy use; once a month for moderate use. See **Figure 25** for grease fitting location.



Figure 25. Grease fitting.

2. **Spur/Table Lifting Gears** — Clean and regrease as determined by visible inspection for dust or grime in the grease. See **Figures 26 and 27** for gear locations.

Always wipe off excess grease from all locations after lubricating!

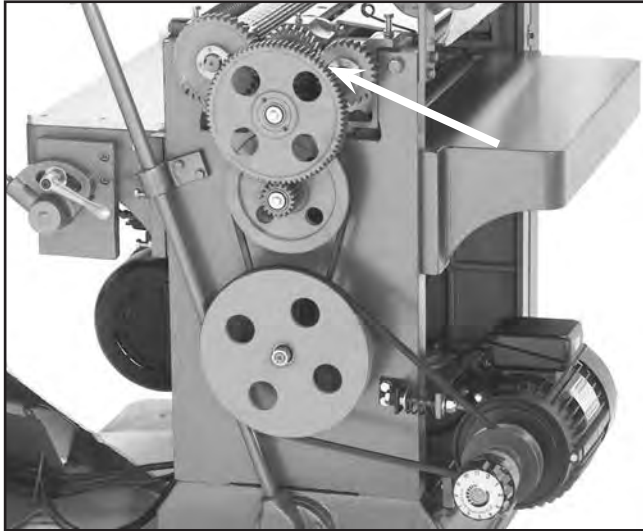

Figure 26. Location of spur gears.



Figure 27. Pull down rubber boots under the table to expose the worm gears that raise and lower the table.

3. **Table Gibs** — Clean and grease gibs where they slide against the planer body as needed per visual inspection.



V-Belt

Avoid getting grease or oil on the V-belts or pulleys. Check the V-belts, as part of a monthly inspection for proper tension and belt condition. Cracking and glazing could result in belt failure. Replace the belt if such conditions appear.

Once a year, under normal conditions, replace the V-belt.

To loosen/tighten belt tension, use the adjustment nuts shown in **Figure 28**.

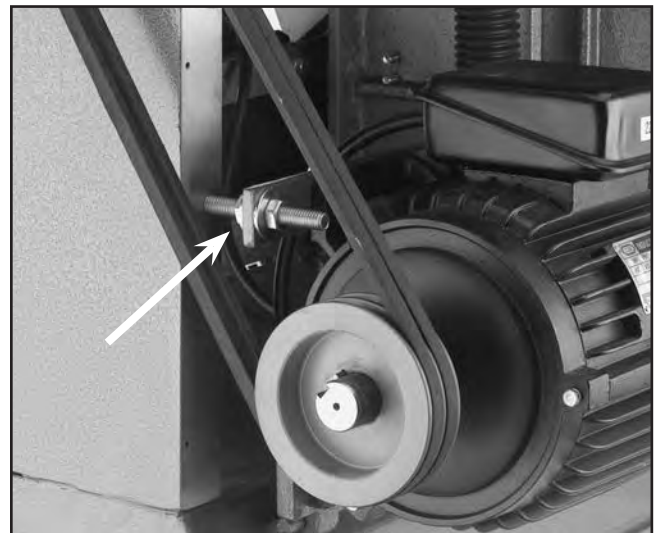

Figure 28. Adjust feed motor V-belt here.



Indexable Inserts (G0544)

The G0544 has a spiral cutterhead with 96 indexable inserts. Each cutter can be rotated to reveal any one of its four cutting edges. Therefore, if one cutting edge becomes dull or damaged, simply rotate it 90° to reveal a fresh cutting edge (**Figure 29**).

In addition, each cutter has a reference dot on one corner. As the cutter is rotated, the reference dot location can be used as an indicator of which edges are used and which are new. When the reference dot revolves back around to its starting position, the cutter should be replaced.

To rotate or change a carbide cutter:

1. DISCONNECT THE PLANER FROM THE POWER SOURCE!
2. Remove any sawdust from the head of the carbide cutter Torx screw.
3. Remove the Torx screw and carbide cutter.
4. Clean all dust and dirt off the cutter and the cutterhead pocket from which the cutter was removed, and replace the cutter so a fresh, sharp edge is facing outward.

Note: Proper cleaning is critical to achieving a smooth finish. Dirt or dust trapped between the cutter and cutterhead will slightly raise the cutter, and make a noticeable marks on your workpieces the next time you plane.

5. Lubricate the Torx screw threads with a light machine oil, wipe the excess oil off the threads, and torque the Torx screw to 48-50 inch/pounds.

Note: Excess oil may squeeze between the cutter and cutterhead, thereby lifting the cutter slightly and affecting workpiece finishes.

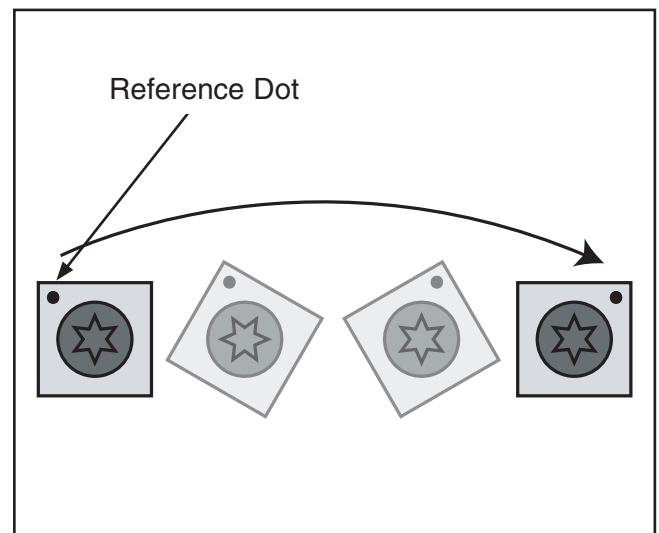
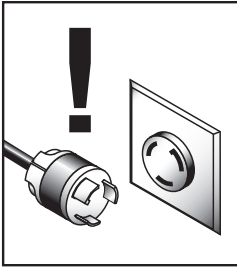

Figure 29. Cutter rotating sequence.



⚠ WARNING
Keep power disconnected from machine when performing any wiring to the machine, or serious personal injury may result!

SINGLE-PHASE
220V POWER SOURCE

G5850Z
G5851Z
G0544

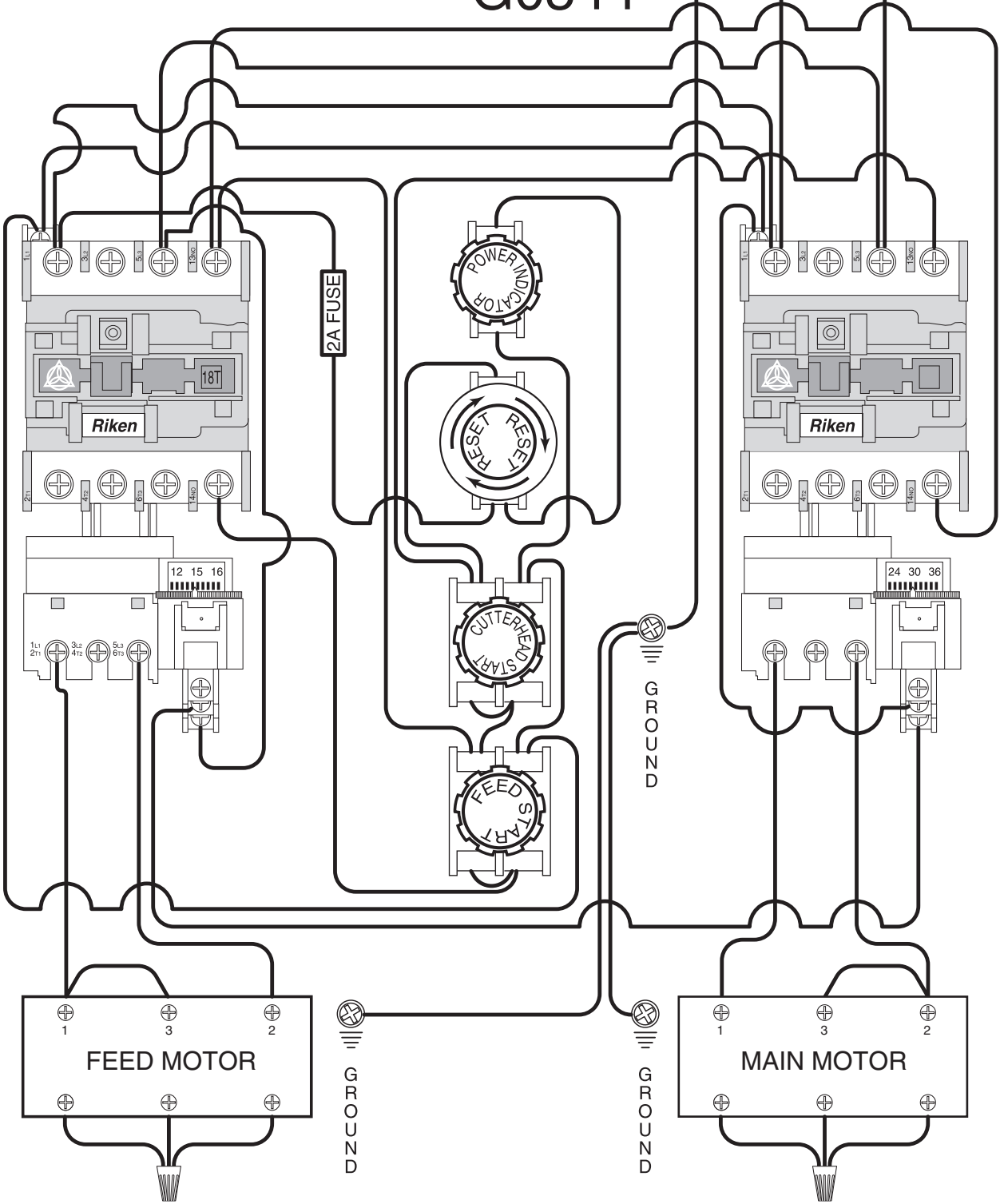

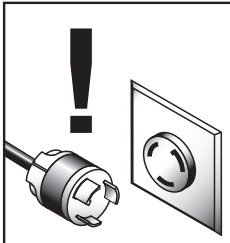

WARNING
Keep power disconnected from machine when performing any wiring to the machine, or serious personal injury may result!

3-PHASE
220V POWER SOURCE

G7213Z

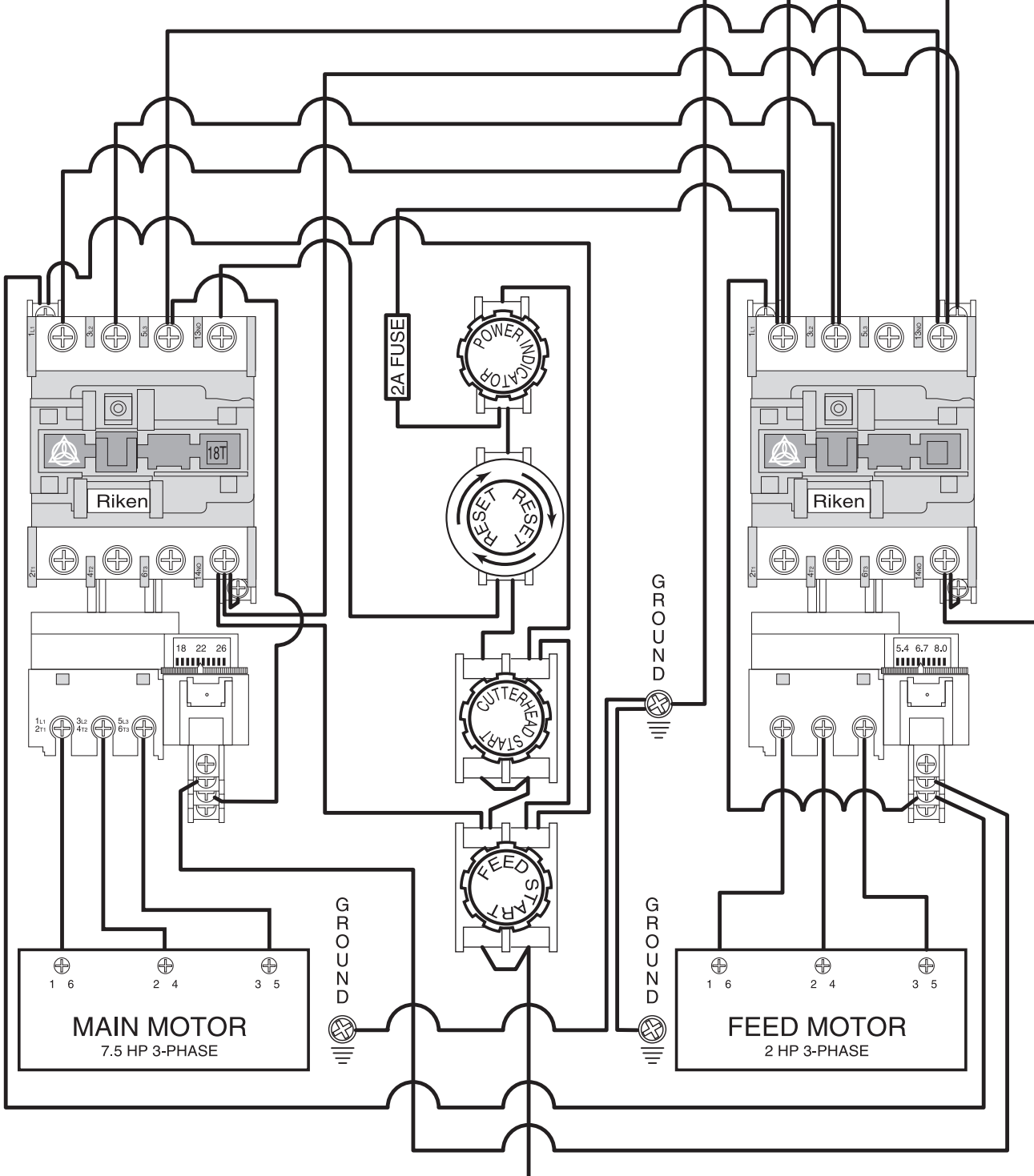

SECTION 8: CLOSURE

The following pages contain general machine data, parts diagrams/lists, troubleshooting guide and Warranty/Return information for your Professional Series Planer.

If you need parts or help in assembling your machine, or if you need operational information, we encourage you to call our Service Department. Our trained service technicians will be glad to help you.

If you have comments dealing specifically with this manual, please write to our Bellingham, Washington location using the address in the *General Information* section. The specifications, drawings, and photographs illustrated in this manual represent the Professional Series Planer as supplied when the manual was prepared. However, due to Grizzly's policy of continuous improvement, changes may be made at any time with no obligation on the part of Grizzly. Whenever possible, though, we send manual updates to all owners of a particular tool or machine. Should you receive one, add the new information to this manual and keep it for reference.

We have included some important safety measures that are essential to the operation of this machine. While most safety measures are generally universal, Grizzly reminds you that each workshop is different and safety rules should be considered as they apply to your specific situation.

WARNING

The Professional Series Planers were specifically designed for wood planing operations only. **DO NOT MODIFY AND/OR USE THIS MACHINE FOR ANY OTHER PURPOSE.** Modifications or improper use of this tool will void the warranty. If you are confused about any aspect of this machine, **DO NOT** use it until all your questions have been answered, or serious personal injury may occur.

We recommend you keep a copy of our current catalog for complete information regarding Grizzly's warranty and return policy. If you need additional technical information relating to this machine, or if you need general assistance or replacement parts, please contact the Service Department listed in the *Introduction* section.

Additional information sources are necessary to realize the full potential of this machine. Trade journals, woodworking magazines and your local library are good places to start.

WARNING

Operating this equipment has the potential for flying debris to cause eye injury. Always wear safety glasses or goggles when operating equipment. Everyday glasses or reading glasses only have impact resistant lenses, they are not safety glasses. Be certain the safety glasses you wear meet the appropriate standards of the American National Standards Institute (ANSI).



WARNING

Like all power tools, there is danger associated with the Professional Series Planers. Accidents are frequently caused by lack of familiarity or failure to pay attention. Use your machine with respect and caution to lessen the possibility of operator injury. If normal safety precautions are overlooked or ignored, serious personal injury may occur.





MACHINE DATA SHEET

Customer Service #: (570) 546-9663 • To Order Call: (800) 523-4777 • Fax #: (800) 438-5901

MODEL G5850Z 20" PROFESSIONAL PLANER MODEL G0544 20" PLANER W/ SPIRAL CUTTERHEAD

Design Type Floor Model

Overall Dimensions:

Table Size21¼" x 28¼"
 Overall Height42¼"
 Overall Depth40½"
 Overall Width.....38"
 Shipping Weight 990 lbs.
 Footprint24½" x 26½"
 Crate Size46" H x 42½" W x 41⅝" D

Capacities:

Maximum Depth of Cut⅝"
 Maximum Width of Cut.....20"

Maximum Cutting Height.....7"
 Minimum Stock Thickness¼"
 Minimum Stock Length.....8"
 Cutterhead Diameter.....3⅝"
 Knives (G5850Z) 4 High Speed Steel / 20" x 1" x ⅛"
 Knives (G0544) Indexable Carbide Inserts / 14 x 14 x 2mm
 Cutterhead Speed 5200 RPM
 Cuts Per Minute 20,800
 Feed Rate Variable 17-26 FPM
 Cuts Per Inch 66-101

Construction:

Table Precision-Ground Cast Iron
 Power Feed Rollers.....Steel, Segmented Infeed, Polished Outfeed
 Cutterhead (G5850Z) 4 Knife Slots, Shielded Ball Bearings
 Cutterhead (G0544) Spiral Cutterhead w/ 96 pc. Inserts

Planer Motor:

Type TEFC Capacitor-Start Induction
 Horsepower 5 HP
 Phase / Voltage Single-Phase / 220V
 Amps25 A
 Cycle / RPM.....60 Hertz / 3450 RPM
 Switch.....Magnetic With Thermal Overload Protector
 Power Transfer..... Twin V-Belt Drive
 Bearings Sealed & Lubricated Ball Bearings

Feed Motor:

Type TEFC Capacitor-Start Induction
 Horsepower 2 HP
 Phase / VoltageSingle-Phase / 220V
 Amps 14
 Cycle / RPM.....60 Hertz / 3450 RPM
 Power Transfer..... Variable Split Pulley System
 Phase / Voltage Single-Phase, 220V

Features:

..... Lever Controlled Bed Rollers
 Handwheel Depth Adjustment
5" Dust Port
Dust Covers Protect Vertical Support Columns and Leadscrews

G5850Z G0544

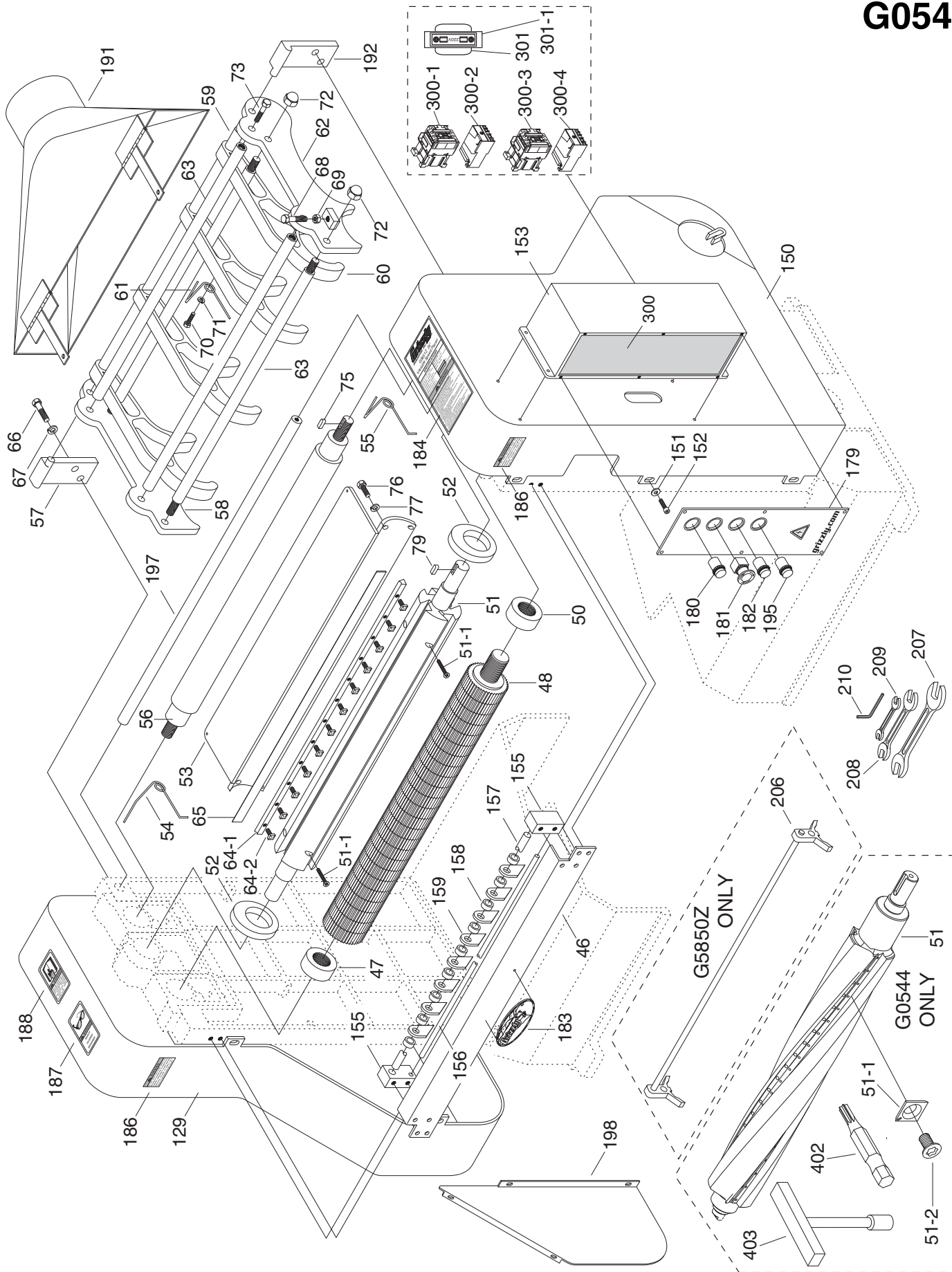

G5850Z G0544

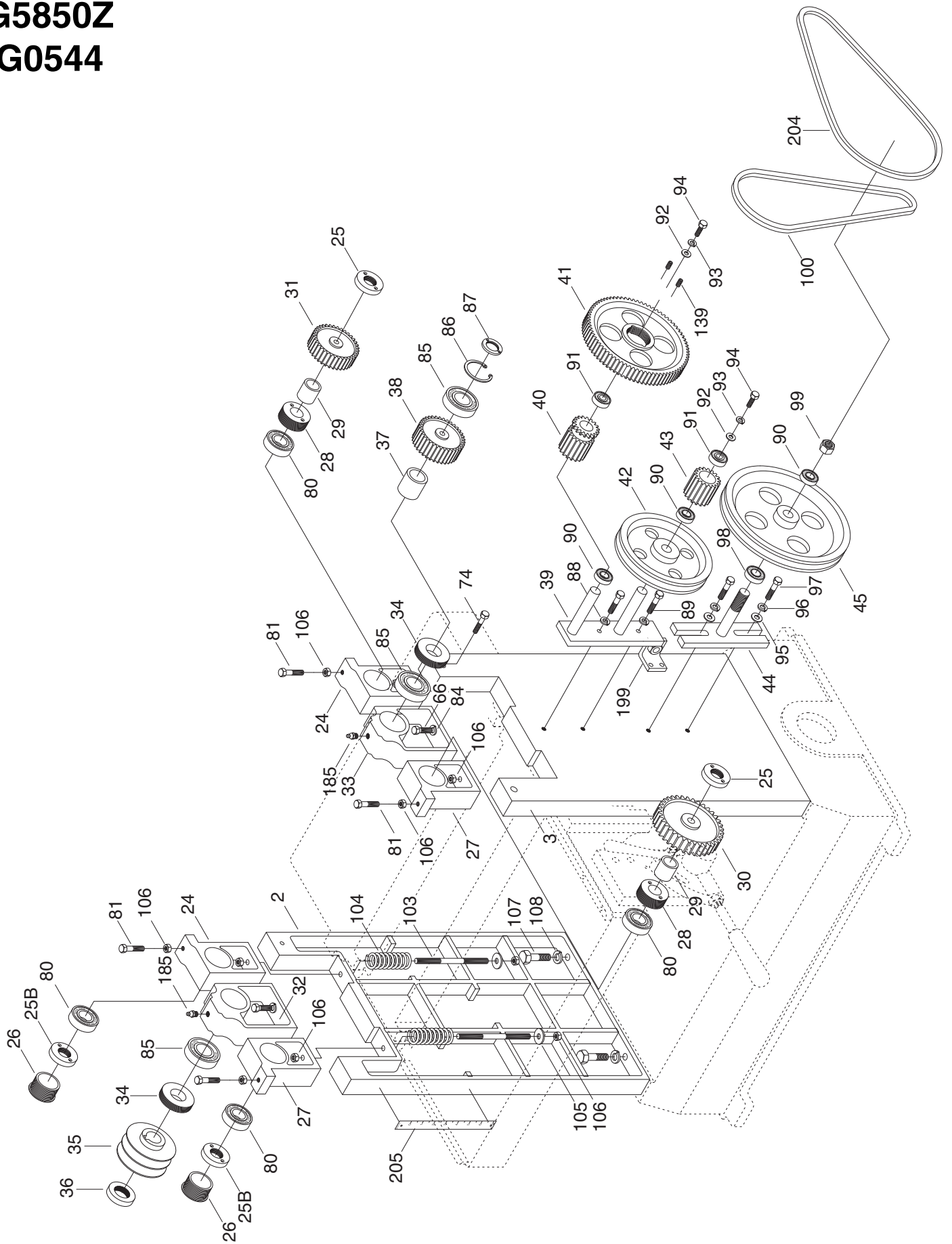

G5850Z G0544

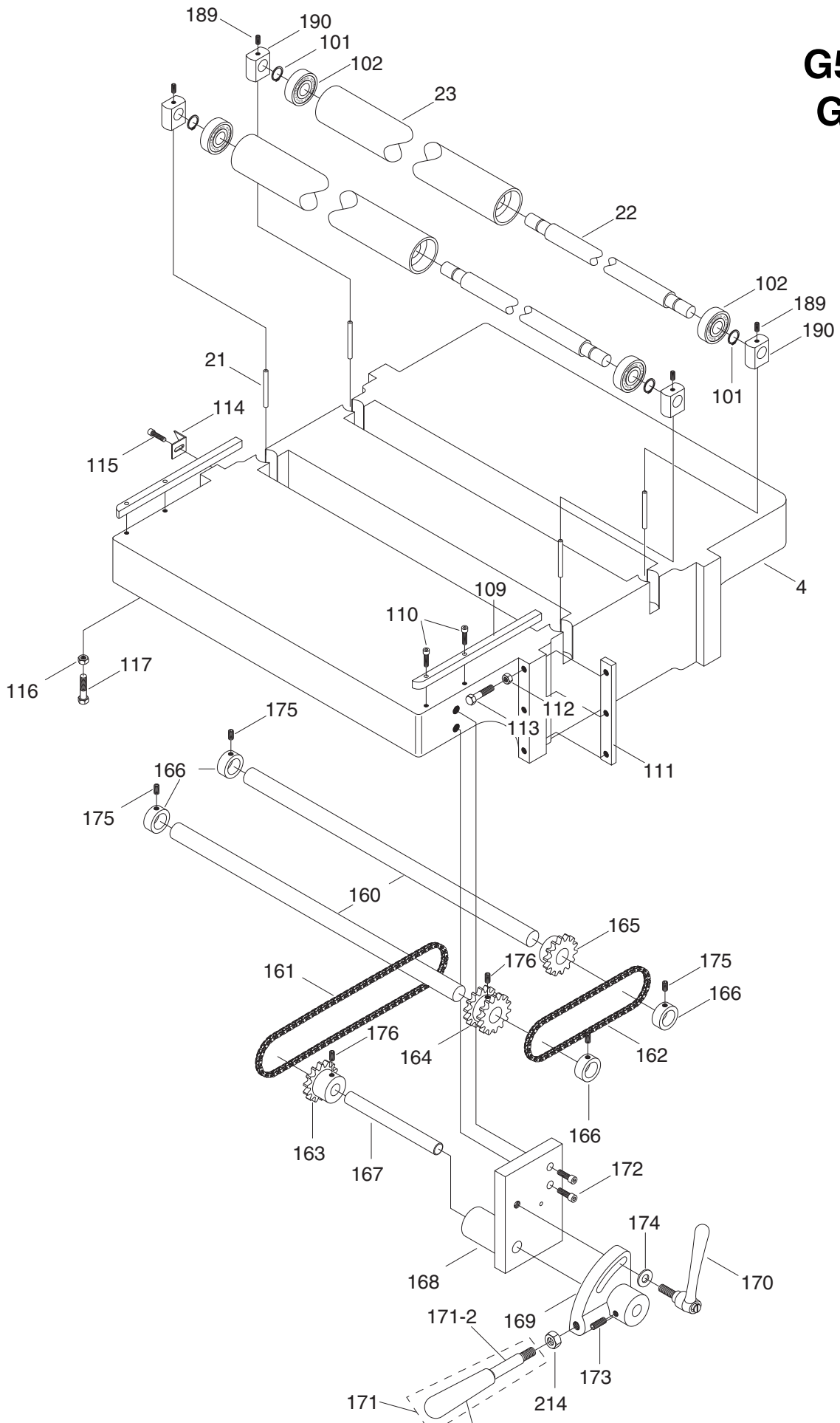

G5850Z/G0544

REF	PART #	DESCRIPTION
1	P5850Z001	BASE
2	P5850Z002	COLUMN
3	P5850Z003	COLUMN
4	P5850Z004	TABLE
5	P5850Z005	GEAR SHAFT
6	P5850Z006	BEVEL GEAR 14T
7	P5850Z007	BEVEL GEAR 24T
8	P5850Z008	END BRACKET
10	P5850Z010	BEVEL GEAR 24T
11	P5850Z011	BEVEL GEAR 13T
12	P5850Z012	BEVEL GEAR HOUSING
13	P5850Z013	HANDWHEEL SHAFT
14	P5850Z014	SHAFT RING
15	P5850Z015	BEARING HOUSING
16	P5850Z016	ELEVATING SCR 1-6 X 17-1/2"
17	P5850Z017	ELEVATING SCR BRACKET LH
18	P5850Z018	ELEVATING SCR 1-6 X 17-1/2"
19	P5850Z019	ELVTNG SCR ADJ M36-2.0
20	P5850Z020	ELEVATING SCR BRACKET RH
21	P5850Z021	TABLE ROLLER ADJ PIN
22	P5850Z022	TABLE ROLLER SHAFT
23	P5850Z023	TABLE ROLLER
24	P5850Z024	OUTFEED ROLLER MOUNT
25	P5850Z025	BEARING LOCKING RING RH
25B	P5850Z025B	BEARING LOCKING RING LH
26	P5850Z026	THREADED CAP
27	P5850Z027	INFEED ROLLER MOUNT
28	P5850Z028	BEARING LOCKING RING
29	P5850Z029	SPACER
30	P5850Z030	INFEED GEAR 38T
31	P5850Z031	OUTFEED GEAR 26T
32	P5850Z032	CUTTERHEAD MOUNT LH
33	P5850Z033	CUTTERHEAD MOUNT RH
34	P5850Z034	BEARING LOCKING RING
35	P5850Z035	PULLEY 2-3/4"
36	P5850Z036	NUT M30-1.5 LH
37	P5850Z037	SPACER
38	P5850Z038	CUTTERHEAD GEAR 25T
39	P5850Z039	ADJUSTING BRACKET
40	P5850Z040	GEAR 14T
41	P5850Z041	GEAR 76T
42	P5850Z042	PULLEY 7"
43	P5850Z043	GEAR 18T
44	P5850Z044	ADJUSTING BRACKET
45	P5850Z045	PULLEY 10"
46	P5850Z046	SAFETY FENDER
47	P5850Z047	LOCK COLLAR LH
48	P5850Z048	INFEED ROLLER SOLID SLEEVE
50	P5850Z050	LOCK COLLAR RH
51	P0544051	SPIRAL CUTTERHEAD
51	P5850Z051	CUTTERHEAD 20" 4 KNIFE
51-1	P0544051-1	INDEXABLE CARBIDE INSERTS 10PK
51-1	P5850Z051	FLAT HEAD SCREW M6-1 X 16
51-2	P0544051-2	FLAT HEAD TORX SCREW T20 M6-1 X15
52	P5850Z052	PRESSURE BAR BRACKET
53	P5850Z053	PRESSURE BAR

REF	PART #	DESCRIPTION
54	P5850Z054	PRESSURE SPRING LEFT
55	P5850Z055	PRESSURE SPRING RIGHT
56	P5850Z056	OUTFEED ROLLER
57	P5850Z057	COVER HINGE BRACKET LH
58	P5850Z058	COVER SIDE PLATE LH
59	P5850Z059	CHIPBREAKER SHAFT
60	P5850Z060	CHIPBREAKER
61	P5850Z061	CHIPBREAKER SPRING
62	P5850Z062	COVER SIDE PLATE RH
63	P5850Z063	RETURN ROLLERS
64-1	P5850Z064-1	GIB W/O GIB BOLTS
64-2	P5850Z064-2	GIB BOLT
65	P5850Z065	KNIFE 4PC 20"
66	P5850Z066	HEX BOLT 3/8"-16 X 1-1/4"
67	P5850Z067	LOCK WASHER 3/8"
68	P5850Z068	HEX BOLT 3/8"-16 X 2"
69	P5850Z069	HEX NUT 3/8"-16
70	P5850Z070	HEX BOLT 1/4"-20 X 5/8"
71	P5850Z071	LOCK WASHER 1/4"
72	P5850Z072	ACORN NUT 1/2"-12
73	P5850Z073	HEX BOLT 5/16"-18 X 1"
74	P5850Z074	HEX BOLT 5/16"-18 X 5/8"
75	P5850Z075	KEY 1/4" X 1/4" X 3/4"
76	P5850Z076	HEX BOLT 5/16"-18 X 5/8"
77	P5850Z077	LOCK WASHER 5/16"
79	P5850Z079	KEY 1/4" X 1/4" X 3/4"
80	P5850Z080	BALL BEARING 6205ZZ
81	P5850Z081	HEX BOLT 3/8"-16 X 13/4"
84	P5850Z084	LOCK WASHER 3/8"
85	P5850Z085	BALL BEARING 6206-2RS
86	P5850Z086	INT RETAINING RING 27MM
87	P5850Z087	LOCKING RING 15/16-16 RH
88	P5850Z088	LOCK WASHER 3/8"
89	P5850Z089	HEX BOLT 3/8"-16 X 1"
90	P5850Z090	BALL BEARING 6002ZZ
91	P5850Z091	BALL BEARING 6201ZZ
92	P5850Z092	FLAT WASHER 5/16"
93	P5850Z093	LOCK WASHER 5/16"
94	P5850Z094	HEX BOLT 5/16"-18 X 3/8"
95	P5850Z095	FLAT WASHER 3/8"
96	P5850Z096	LOCK WASHER 3/8"
97	P5850Z097	HEX BOLT 3/8"-16 X 1"
98	P5850Z098	BALL BEARING 6003ZZ
99	P5850Z099	HEX NUT 5/8"-11
100	P5850Z100	V-BELT A32
101	P5850Z101	EXT RETAINING RING 19MM
102	P5850Z102	BALL BEARING 6304ZZ
103	P5850Z103	STUD-UDE 3/8-16 X 6-3/16 1-1/8RH 1-7/8RH
104	P5850Z104	COMPRESSION SPRING
105	P5850Z105	FLAT WASHER 3/8"
106	P5850Z106	HEX NUT 3/8"-16
107	P5850Z107	HEX BOLT 1/2"-12 X 1-1/2"
108	P5850Z108	LOCK WASHER 1/2"
109	P5850Z109	TABLE EDGE GUIDE
110	P5850Z110	CAP SCREW 1/4-20 X 1/2

G5850Z/G0544

REF	PART #	DESCRIPTION
111	P5850Z111	TABLE GIB
112	P5850Z112	HEX NUT 3/8"-16
113	P5850Z113	HEX BOLT 3/8"-16 X 1-3/4"
114	P5850Z114	SCALE POINTER
115	P5850Z115	CAP SCREW 1/4"-20 X 3/8
116	P5850Z116	HEX NUT 3/8"-16
117	P5850Z117	HEX BOLT 3/8"-16 X 2"
119	P5850Z119	HEX BOLT 5/16"-18 X 1-1/4"
120	P5850Z120	LOCK WASHER 5/16"
121	P5850Z121	HEX BOLT 5/16"-18 X 1"
122	P5850Z122	DUST BOOT
123	P5850Z123	THRUST BEARING 2904
124	P5850Z124	HEX BOLT 5/16"-18 X 1"
125	P5850Z125	LOCK WASHER 5/16"
126	P5850Z126	MOTOR 5HP 220V 1PH
127	P5850Z127	PULLEY
128	P5850Z128	V-BELT A60
129	P5850Z129	GUARD LEFT
131	P5850Z131	HEX BOLT 3/8"-16 X 1-1/2"
132	P5850Z132	FLAT WASHER 3/8"
133	P5850Z133	LOCK WASHER 3/8"
134	P5850Z134	HEX NUT 3/8"-16
135	P5850Z135	MOTOR ADJUSTMENT BRACKET
136	P5850Z136	HEX NUT 3/8"-16
137	P5850Z137	HEX BOLT 5/16"-18 X 1"
138	P5850Z138	LOCK WASHER 5/16"
139	P5850Z139	SET SCREW 1/4"-20 X 3/8"
140	P5850Z140	SET SCREW 5/16"-18 X 3/8"
142	P5850Z142	FLAT WASHER 1/2"
143	P5850Z143	LOCK WASHER 5/16"
144	P5850Z144	HEX BOLT 5/16"-18 X 1"
145	P5850Z145	ACORN NUT 1/2"-12
146	P5850Z146	HANDWHEEL
147	P5850Z147	MOVEABLE HANDLE
148	P5850Z148	LOCK WASHER 5/16"
149	P5850Z149	HEX BOLT 5/16"-18 X 1"
150	P5850Z150	GUARD RIGHT
151	P5850Z151	FLAT WASHER 1/4"
152	P5850Z152	CAP SCREW 1/4"-20 X 1/2
153	P5850Z153	CONTROL CASE
154	P5850Z154	MOTOR SUPPORT
155	P5850Z155	MOUNTING BRACKET LH/RH
156	P5850Z156	SHAFT
157	P5850Z157	FIXED SHAFT
158	P5850Z158	SPACER
159	P5850Z159	ANTI KICKBACK TOOTH
160	P5850Z160	CHAIN SHAFT
161	P5850Z161	CHAIN 1/2" X 26"
162	P5850Z162	CHAIN 1/2" X 21-1/2"
163	P5850Z163	SPROCKET 14T
164	P5850Z164	DOUBLE SPROCKET 14T
165	P5850Z165	SPROCKET 14T
166	P5850Z166	COLLAR
167	P5850Z167	SHAFT
168	P5850Z168	HUB MOUNTING PLATE

REF	PART #	DESCRIPTION
169	P5850Z169	ARC HUB
170	P5850Z170	LOCK HANDLE 1/2-12
171	P5850Z171	HANDLE ASSEMBLY 1/2-12
172	P5850Z172	CAP SCREW 5/16"-18 X 1
173	P5850Z173	SET SCREW 3/8"-16 X 3/8"
174	P5850Z174	FLAT WASHER 1/2"
175	P5850Z175	SET SCREW 5/16"-18 X 3/8"
176	P5850Z176	SET SCREW 5/16"-18 X 1/4"
177	P5850Z177	FEED MOTOR 2HP 220V 1PH
178	P5850Z178	VARIABLE SPEED CONTROLLER V1
179	P5850Z179	CONTROL PANEL
180	P5850Z180	POWER INDICATOR LIGHT
181	P5850Z181	EMERGENCY STOP SWITCH
182	P5850Z182	CUTTERHEAD MOTOR ON BUTTON
183	P5850Z183	GRIZZLY NAME PLATE
184	P5850Z184	MACHINE ID LABEL
185	P5850Z185	GREASE FITTING
186	P5850Z186	DO NOT OPEN WARNING
187	P5850Z187	SAFETY GLASSES LABEL
188	P5850Z188	READ MANUAL LABEL
189	P5850Z189	SET SCREW 1/4"-20 X 1/4"
190	P5850Z190	BED ROLLER BASE
191	P5850Z191	DUST HOOD
192	P5850Z192	CHIPBREAKER SIDE PLATE
193	P5850Z193	HEX NUT 1/2"-12
194	P5850Z194	HEX BOLT 1/2"-12 X 4"
195	P5850Z195	POWER FEED ON BUTTON
197	P5850Z197	SUPPORT SHAFT
198	P5850Z198	COVER
199	P5850Z199	MOTOR ADJUSTMENT BRACKET
200	P5850Z200	KEY 8 X 10 X 64
201	P5850Z201	FLAT WASHER 3/8"
202	P5850Z202	HEX BOLT 3/8-16 X 6
203	P5850Z203	COMPRESSION SPRING
204	P5850Z204	V-BELT A46
205	P5850Z205	DEPTH GAUGE
206	P5850Z206	KNIFE GAUGE ASSEMBLY
207	P5850Z207	WRENCH 17 X 19MM OPEN ENDS
208	P5850Z208	WRENCH 12 X 14MM OPEN ENDS
209	P5850Z209	WRENCH 8 X 10MM OPEN ENDS
210	P5850Z210	HEX WRENCH 4MM
211	P5850Z211	*DISCD*LOCKING NUT
212	P5850Z212	*DISCD*SPACER
213	P5850Z213	HEX BOLT 3/8-16 X 6
214	P5850Z214	HEX NUT 1/2"-12
300	P5850Z300	MAG SWITCH ASSY
300-1	P5850Z300-1	CONTACTOR RAB-18T10 RIKEN
300-2	P5850Z300-2	HEATER FEED MOTOR BTH18T2H18 12/18A
300-3	P5850Z300-3	CONTACTOR RAB-35T10
300-4	P5850Z300-4	HEATER CUTTERHEAD BTH352H36 24/36A RIKEN
301	P5850Z301	FUSE HOLDER
301-1	P5850Z301-1	FUSE 2A
402	P0544402	T-20 TORX BIT
403	P0544403	T-20 TORX DRIVER



MACHINE DATA SHEET

Customer Service #: (570) 546-9663 • To Order Call: (800) 523-4777 • Fax #: (800) 438-5901

MODEL G5851Z 24" PROFESSIONAL PLANER

Design Type Floor Model

Overall Dimensions:

Table Size 24 $\frac{1}{8}$ " x 31 $\frac{1}{8}$ "
 Height 37"
 Overall Depth 40 $\frac{1}{2}$ "
 Overall Width 42"
 Shipping Weight 1240 lbs.
 Crate Size 46" H x 47 $\frac{1}{4}$ " W x 42 $\frac{1}{2}$ " D
 Footprint 24 $\frac{1}{2}$ " L x 20 $\frac{1}{2}$ " W

Capacities:

Maximum Depth of Cut $\frac{3}{8}$ "
 Maximum Width of Cut 24"

Maximum Cutting Height 7"
 Minimum Stock Thickness $\frac{1}{4}$ "
 Minimum Stock Length 8"
 Cutterhead Diameter 3 $\frac{1}{8}$ "
 Knives (#/Dimension) 4 High Speed Steel / 24" x 1" x $\frac{1}{8}$ "
 Cutterhead Speed 5200 RPM
 Cuts Per Minute 20,800
 Feed Rate Variable 17-26 FPM
 Cuts Per Inch 66-101

Construction:

Table Precision-Ground Cast Iron
 Power Feed Rollers Steel, Segmented Infeed
 Out Feed Roller Fine Finished Steel
 Cutterhead One Piece Machine Shaft; 4 Knife Slots; Shielded Ball Bearings

Planer Motor:

Type TEFC Capacitor-Start Induction
 Horsepower 5 HP
 Phase / Voltage Single-Phase / 220V
 Amps 25
 Cycle / RPM 60 Hertz / 3450 RPM
 Switch Magnetic With Thermal Overload Protector
 Power Transfer Twin V-Belt Drive
 Bearings Sealed & Lubricated Ball Bearings

Feed Motor:

Type TEFC Capacitor-Start Induction
 Horsepower 2 HP
 Phase / Voltage Single-Phase / 220V
 Amps 12
 Cycle / RPM 60 Hertz / 3450 RPM
 Power Transfer Variable Split Pulley System

Features:

..... Lever Controlled Bed Rollers
 Handwheel Depth Adjustment
 Segmented Chip Breaker
 Table Locks
 5" Dust Port
 Inch & Metric Measurement Scale
 Board Return Rollers
 Dust Covers Protect Vertical Support Columns and Leadscrews
 Grease Fittings on Cutterhead



MACHINE DATA SHEET

Customer Service #: (570) 546-9663 • To Order Call: (800) 523-4777 • Fax #: (800) 438-5901

MODEL G7213Z 24" PROFESSIONAL PLANER

Design Type Floor Model

Overall Dimensions:

Table Size 31½" x 24"
 Height 37"
 Overall Depth 33"
 Overall Width 27½"
 Shipping Weight 1030 lbs.
 Footprint 30" L x 20½" W
 Crate Size 42½" L x 36" W x 45" H

Capacities:

Maximum Depth of Cut ¾"
 Maximum Width of Cut 24"

Maximum Cutting Height 7"
 Minimum Stock Thickness ¼"
 Minimum Stock Length 7½"
 Cutterhead Speed 5200 RPM
 Cuts Per Inch 66-101
 Cuts Per Minute 20,800
 Feed Rate 17-26 FPM

Construction:

Table Precision-Ground Cast Iron
 Power Feed Rollers Steel
 Out Feed Roller Fine Finished Steel
 Cutterhead 4 Knife Slots Sealed Ball Bearings with Grease Fitting

Planer Motor:

Type TEFC Induction
 Horsepower 7½ HP
 Phase / Voltage Three-Phase; 220 / 440V
 Amps 20 / 10
 Cycle / RPM 60 Hertz / 3450 RPM
 Prewired 220V
 Switch Magnetic With Thermal Overload Protector / 220V Only
 Power Transfer Two Belt Drive

Feed Motor:

Type TEFC Induction
 Horsepower 2 HP
 Phase / Voltage Three-Phase; 220 / 440V
 Amps 6 / 3
 Prewired 220V
 Power Transfer Variable Split Pulley System

Features:

..... Lever Control Bed Rollers
 Segmented Chip Breaker and Infeed Roller
 Table Locks
 5" Collar Chip Chute
 Inch & Metric Measurement Scale
 Variable speed feed

Specifications, while deemed accurate, are not guaranteed.

G5851Z
G7213Z

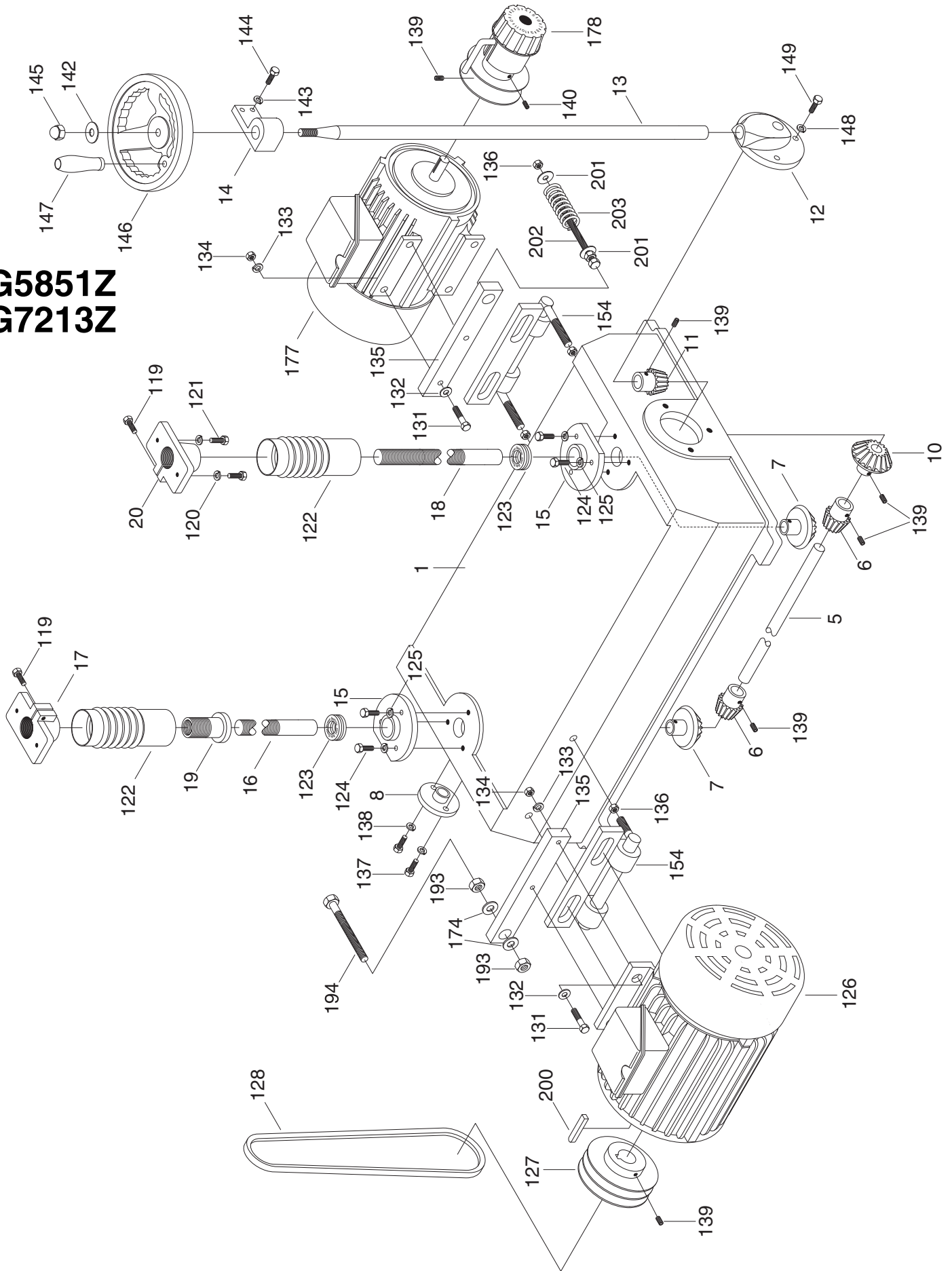

**G5851Z
G7213Z**

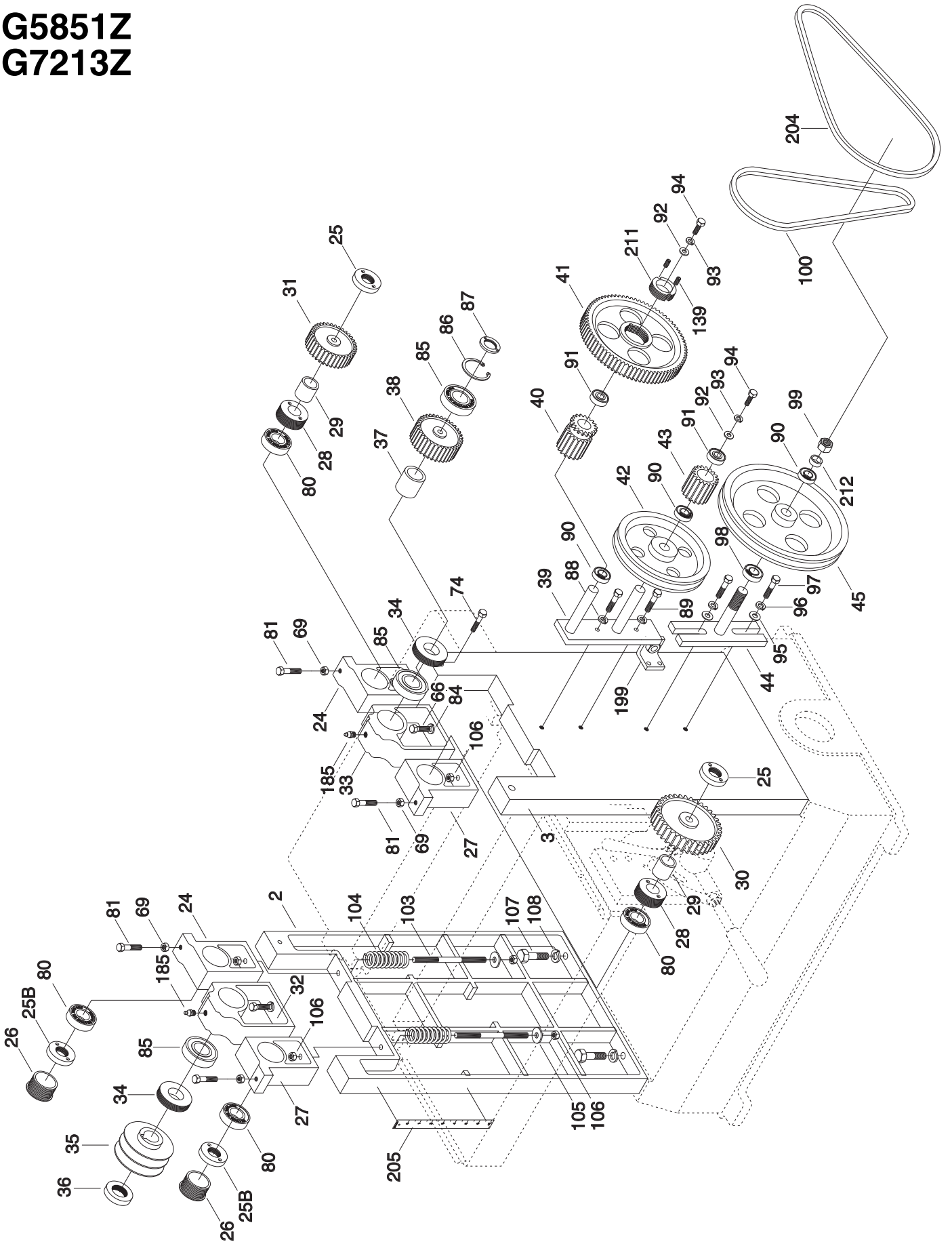

G5851Z G7213Z

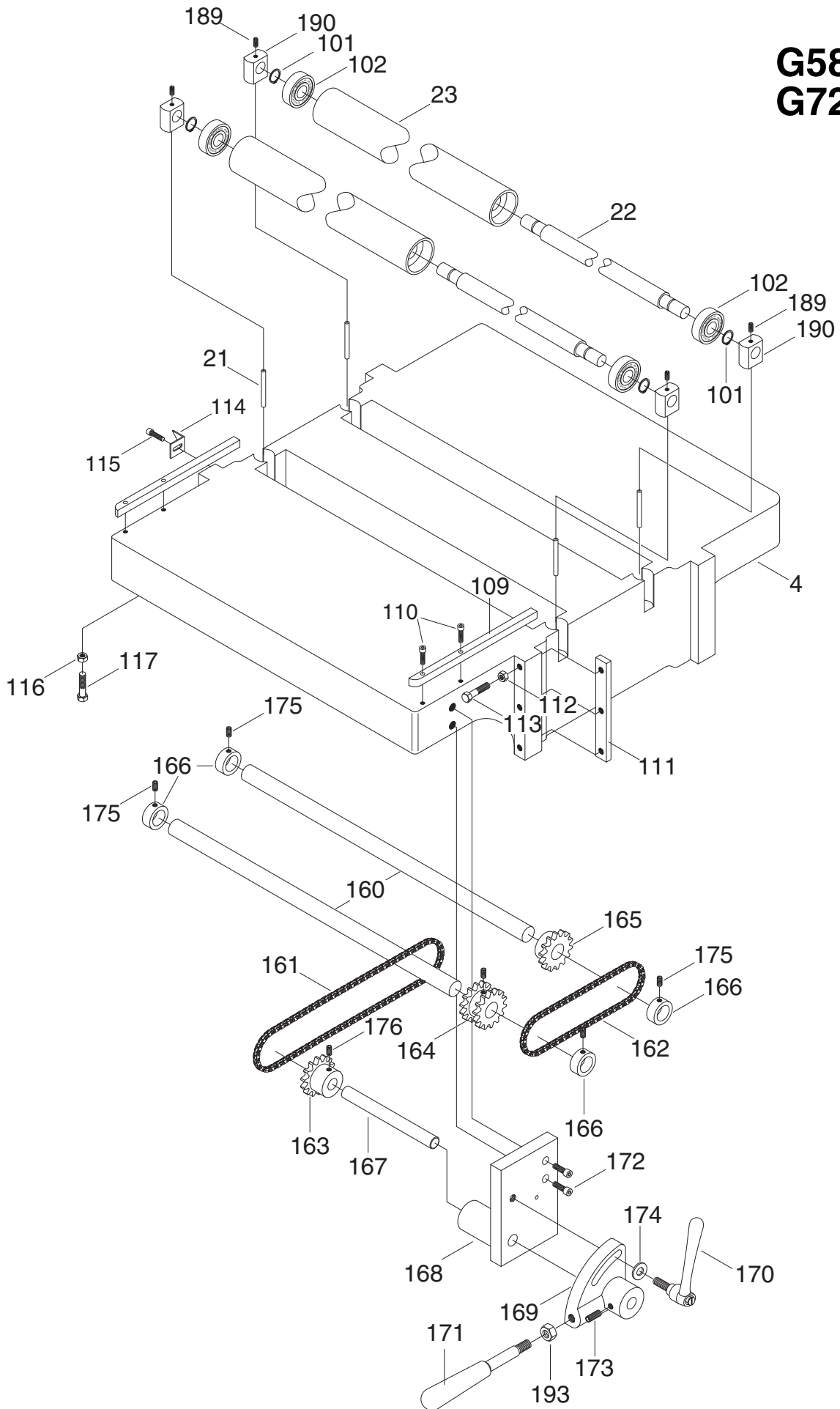

G5851Z & G7213Z

REF	PART #	DESCRIPTION
1	P5851Z001	BASE
2	P5851Z002	COLUMN
3	P5851Z003	COLUMN
4	P5851Z004	TABLE
5	P5851Z005	GEAR SHAFT
6	P5851Z006	BEVEL GEAR
7	P5851Z007	BEVEL GEAR
8	P5851Z008	END BRACKET
10	P5851Z010	BEVEL GEAR
11	P5851Z011	BEVEL GEAR
12	P5851Z012	BEVEL GEAR HOUSING
13	P5851Z013	HANDWHEEL SHAFT
14	P5851Z014	SHAFT RING
15	P5851Z015	BEARING HOUSING
16	P5851Z016	ELEVATING SCREW 1-6X17-1/2"
17	P5851Z017	ELEVATING SCREW BRACKET LEFT SIDE
18	P5851Z018	ELEVATING SCREW 1-6X17-1/2"
19	P5851Z019	ELEVATING SCREW ADJUSTING NUT
20	P5851Z020	ELEVATING SCREW BRACKET RIGHT SIDE
21	P5851Z021	TABLE ROLLER ADJ PIN
22	P5851Z022	TABLE ROLLER SHAFT
23	P5851Z023	TABLE ROLLER
24	P5851Z024	OUTFEED ROLLER MOUNT LH
25	P5851Z025	BEARING LOCKING RING RH
25B	P5851Z025B	BEARING LOCKING RING LH
26	P5851Z026	ROUND NUT
27	P5851Z027	INFEED ROLLER MOUNT LH
28	P5851Z028	BEARING LOCKING RING
29	P5851Z029	SPACER
30	P5851Z030	INFEED GEAR 38T
31	P5851Z031	OUTFEED GEAR 26T
32	P5851Z032	CUTTERHEAD MOUNT LH
33	P5851Z033	CUTTERHEAD MOUNT RH
34	P5851Z034	BEARING LOCKING RING
35	P5851Z035	PULLEY 2-3/4"
36	P5851Z036	NUT M30-1.5 LH
37	P5851Z037	SPACER
38	P5851Z038	CUTTERHEAD GEAR 25T
39	P5851Z039	ADJUSTING BRACKET
40	P5851Z040	GEAR 14T
41	P5851Z041	GEAR 76T
42	P5851Z042	PULLEY 7"
43	P5851Z043	GEAR 18T
44	P5851Z044	ADJUSTING BRACKET
45	P5851Z045	PULLEY 10"
46	P5851Z046	SAFETY FENDER
47	P5851Z047	LOCK COLLAR LH
48	P5851Z048	INFEED ROLLER
50	P5851Z050	LOCK COLLAR RH
51	P5851Z051	CUTTERHEAD 24" 4 BLADE
51-1	P5851Z051-1	FLAT HEAD SCREW M6-1 X 16
52	P5851Z052	PRESSURE BAR BRACKET
53	P5851Z053	PRESSURE BAR
54	P5851Z054	PRESSURE SPRING LEFT

REF	PART #	DESCRIPTION
55	P5851Z055	SPRING
56	P5851Z056	OUTFEED ROLLER
57	P5851Z057	COVER HINGE BRACKET LH
58	P5851Z058	COVER SIDE PLATE LH
59	P5851Z059	CHIPBREAKER SHAFT
60	P5851Z060	CHIPBREAKER
61	P5851Z061	CHIPBREAKER SPRING
62	P5851Z062	COVER SIDE PLATE RH
63	P5851Z063	RETURN ROLLER 5/16" INSIDE THREAD
64	P5851Z064	GIB W/ GIB BOLTS
64A	P5851Z064A	KNIFE SETTING GAUGE
65	P5851Z065	KNIFE 4PC 24 X 1"
66	P5851Z066	HEX BOLT 3/8-16 X 1-1/4
67	P5851Z067	LOCK WASHER 3/8
68	P5851Z068	HEX BOLT 3/8-16 X 2
69	P5851Z069	HEX NUT 3/8"-16
70	P5851Z070	HEX BOLT 1/4-20 X 5/8
71	P5851Z071	LOCK WASHER 1/4
72	P5851Z072	ACORN NUT 1/2-12
73	P5851Z073	HEX BOLT 5/16-18 X 1
74	P5851Z074	HEX BOLT 5/16-18 X 5/8
75	P5851Z075	KEY 1/4 X 1/4 X 3/4
76	P5851Z076	HEX BOLT 5/16-18 X 5/8
77	P5851Z077	LOCK WASHER 5/16
79	P5851Z079	KEY 1/4 X 1/4 X 3/4
80	P5851Z080	BALL BEARING 6205ZZ
81	P5851Z081	HEX BOLT 3/8-16 X 1-3/4
84	P5851Z084	LOCK WASHER 3/8
85	P5851Z085	BALL BEARING 6206ZZ
86	P5851Z086	INT RETAINING RING 27MM
87	P5851Z087	BEARING LOCKING RING 15/16-16 RH R SIDE
88	P5851Z088	LOCK WASHER 3/8
89	P5851Z089	HEX BOLT 3/8-16 X 1
90	P5851Z090	BALL BEARING 6002ZZ
91	P5851Z091	BALL BEARING 6201ZZ
92	P5851Z092	FLAT WASHER 5/16
93	P5851Z093	LOCK WASHER 5/16
94	P5851Z094	HEX BOLT 5/16-18 X 3/8
95	P5851Z095	FLAT WASHER 3/8
96	P5851Z096	LOCK WASHER 3/8
97	P5851Z097	HEX BOLT 3/8-16 X 1
98	P5851Z098	BALL BEARING 6003ZZ
99	P5851Z099	HEX NUT 5/8"-11
100	P5851Z100	V-BELT 4L320 (QTY 1)
101	P5851Z101	EXT RETAINING RING 19MM
102	P5851Z102	BALL BEARING 6304ZZ
103	P5851Z103	STUD 3/8"-16 X 6"
104	P5851Z104	SPRING
105	P5851Z105	FLAT WASHER 3/8
106	P5851Z106	HEX NUT 3/8"-16
107	P5851Z107	HEX BOLT 1/2-12 X 1-1/2
108	P5851Z108	LOCK WASHER 1/2
109	P5851Z109	TABLE EDGE GUIDE
110	P5851Z110	CAP SCREW 1/4-20 X 1/2

G5851Z & G7213Z

REF	PART #	DESCRIPTION
111	P5851Z111	TABLE GIB
112	P5851Z112	HEX NUT 3/8"-16
113	P5851Z113	HEX BOLT 3/8-16 X 1-3/4
114	P5851Z114	SCALE POINTER
115	P5851Z115	CAP SCREW 1/4-20 X 3/8
116	P5851Z116	HEX NUT 3/8"-16
117	P5851Z117	HEX BOLT 3/8-16 X 2-1/2
119	P5851Z119	HEX BOLT 5/16-18 X 1-1/4
120	P5851Z120	LOCK WASHER 5/16
121	P5851Z121	HEX BOLT 5/16-18 X 1
122	P5851Z122	DUST BOOT
123	P5851Z123	BALL BEARING 2904
124	P5851Z124	HEX BOLT 5/16-18 X 1
125	P5851Z125	LOCK WASHER 5/16
126	P5851Z126	MOTOR 5HP 220V 1PH
127	P5851Z127	PULLEY 5"
128	P5851Z128	BELT A64
129	P5851Z129	LEFT GUARD
131	P5851Z131	HEX BOLT 3/8-16 X 1-1/2
132	P5851Z132	FLAT WASHER 3/8
133	P5851Z133	LOCK WASHER 3/8
134	P5851Z134	HEX NUT 3/8"-16
135	P5851Z135	HEXAGON SCREW
136	P5851Z136	HEX NUT 3/8"-16
137	P5851Z137	HEX BOLT 5/16-18 X 1
138	P5851Z138	LOCK WASHER 5/16
139	P5851Z139	SET SCREW 1/4-20 X 3/8
140	P5851Z140	SET SCREW 5/16-18 X 3/8
142	P5851Z142	FLAT WASHER 1/2
143	P5851Z143	LOCK WASHER 5/16
144	P5851Z144	HEX BOLT 5/16-18 X 1
145	P5851Z145	ACORN NUT 1/2-12
146	P5851Z146	HANDWHEEL
147	P5851Z147	MOVEABLE HANDLE
148	P5851Z148	LOCK WASHER 5/16
149	P5851Z149	HEX BOLT 5/16-18 X 1
150	P5851Z150	RIGHT GUARD
151	P5851Z151	FLAT WASHER 1/4
152	P5851Z152	CAP SCREW 1/4-20 X 1/2
153	P5851Z153	CONTROL CASE PLASTIC V1.01.99
154	P5851Z154	SUPPORT OF MOTOR COLUMN
155	P5851Z155	MOUNTING BRACKET
156	P5851Z156	SHAFT
157	P5851Z157	FIXED SHAFT
158	P5851Z158	SPACER
159	P5851Z159	SAFETY TOOTH
160	P5851Z160	CHAIN SHAFT
161	P5851Z161	CHAIN 1/2 X 28"
162	P5851Z162	CHAIN 1/2" X 21 1/2"
163	P5851Z163	SPROCKET 14T
164	P5851Z164	DOUBLE SPROCKET 14T
165	P5851Z165	SPROCKET 14T
166	P5851Z166	COLLAR
167	P5851Z167	SHAFT

REF	PART #	DESCRIPTION
168	P5851Z168	HUB MOUNTING PLATE
169	P5851Z169	ARC HUB
170	P5851Z170	LOCK HANDLE 1/2-12
171	P5851Z171	HANDLE 1/2-12
172	P5851Z172	CAP SCREW 5/16-18 X 1
173	P5851Z173	SET SCREW 3/8-16 X 3/8
174	P5851Z174	FLAT WASHER 1/2
175	P5851Z175	SET SCREW 5/16-18 X 3/8
176	P5851Z176	SET SCREW 5/16-18 X 1/4
177	P5851Z177	FEED MOTOR 2HP 220V
178	P5851Z178	BELT GUARD LABEL
179	P5851Z179	CONTROL PANEL
180	P5851Z180	GRIZZLY NAMEPLATE 8W X 3.5H
181	P5851Z181	EMERGENCY STOP SWITCH
182	P5851Z182	ON SWITCH
183	P5851Z183	GRIZZLY NAME PLATE
184	P5851Z184	MACHINE ID LABEL
185	P5851Z185	GREASE FITTING
186	P5851Z186	DO NOT OPEN WARNING
187	P5851Z187	SAFETY GLASSES 2W X 3.3H
188	P5851Z188	READ MANUAL 2W X 3.3H
189	P5851Z189	SET SCREW 1/4-20 X 1/4
190	P5851Z190	BED ROLLER BASE
191	P5851Z191	DUST HOOD 24"
192	P5851Z192	CHIPBREAKER SIDE PLATE
193	P5851Z193	HEX NUT 1/2"-13
194	P5851Z194	HEX BOLT 1/2-12 X 4
195	P5851Z195	FEED POWER SWITCH
196	P5851Z196	KNIFE SETTING GIB
197	P5851Z197	SUPPORT SHAFT
198	P5851Z198	COVER
199	P5851Z199	MOTOR ADJ BRACKET FOR FEED MOTOR
200	P5851Z200	KEY 8 X 10 X 64
201	P5851Z201	FLAT WASHER 3/8
202	P5851Z202	HEX BOLT 3/8-16 X 6
203	P5851Z203	SPRING
204	P5851Z204	V-BELT 4L460 (QTY 1)
205	P5851Z205	DEPTH GAUGE
206	P5851Z206	KNIFE SETTING JIG
207	P5851Z207	WRENCH 17 X 19
208	P5851Z208	COMBO WRENCH 12/14MM
209	P5851Z209	WRENCH 8 X 10
210	P5851Z210	HEX WRENCH 4MM
211	P5851Z211	LOCKING NUT
212	P5851Z212	SPACER
300	P5850Z300	MAGNETIC SWITCH ASSY
300	P7213Z300	MAGNETIC SWITCH 3-PH
300-1	P7213Z300-1	CONTACTOR - FEED MOTOR
300-2	P7213Z300-2	OVERLOAD RELAY - FEED MOTOR
300-3	P7213Z300-3	CONTACTOR - CUTTERHEAD
300-4	P7213Z300-4	OVERLOAD RELAY - CUTTERHEAD
301	P5850Z301	FUSE HOLDER
301-1	P5850Z301-1	FUSE 2A
302	P5850Z180	INDICATOR LIGHT (220V)

WARRANTY AND RETURNS

Grizzly Industrial, Inc. warrants every product it sells for a period of **1 year** to the original purchaser from the date of purchase. This warranty does not apply to defects due directly or indirectly to misuse, abuse, negligence, accidents, repairs or alterations or lack of maintenance. This is Grizzly's sole written warranty and any and all warranties that may be implied by law, including any merchantability or fitness, for any particular purpose, are hereby limited to the duration of this written warranty. We do not warrant or represent that the merchandise complies with the provisions of any law or acts unless the manufacturer so warrants. In no event shall Grizzly's liability under this warranty exceed the purchase price paid for the product and any legal actions brought against Grizzly shall be tried in the State of Washington, County of Whatcom.

We shall in no event be liable for death, injuries to persons or property or for incidental, contingent, special, or consequential damages arising from the use of our products.

To take advantage of this warranty, contact us by mail or phone and give us all the details. We will then issue you a "Return Number," which must be clearly posted on the outside as well as the inside of the carton. We will not accept any item back without this number. Proof of purchase must accompany the merchandise.

The manufacturers reserve the right to change specifications at any time because they constantly strive to achieve better quality equipment. We make every effort to ensure that our products meet high quality and durability standards and we hope you never need to use this warranty.

Please feel free to write or call us if you have any questions about the machine or the manual.

Thank you again for your business and continued support. We hope to serve you again soon.

WARRANTY CARD

Name _____
 Street _____
 City _____ State _____ Zip _____
 Phone Number _____ E-Mail _____ FAX _____
MODEL # _____ **Serial#** _____ **Order #** _____

The following information is given on a voluntary basis. It will be used for marketing purposes to help us develop better products and services. Of course, all information is strictly confidential.

1. How did you learn about us?
 Advertisement Friend
 Catalog World Wide Web
 Other _____
2. Which of the following magazines do you subscribe to.
 American Woodworker Practical Homeowner
 Cabinetmaker Shop Notes
 Family Handyman Today's Homeowner
 Fine Homebuilding WOOD
 Fine Woodworking Wooden Boat
 Home Handyman Woodshop News
 Journal of Light Construction Woodsmith
 Old House Journal Woodwork
 Popular Mechanics Woodworker
 Popular Science Woodworker's Journal
 Popular Woodworking Workbench
 Other _____
3. Which of the following woodworking/remodeling shows do you watch?
 Backyard America The New Yankee Workshop
 Home Time This Old House
 The American Woodworker Woodwright's Shop
 Other _____
4. What is your annual household income?
 \$20,000-\$29,999 \$60,000-\$69,999
 \$30,000-\$39,999 \$70,000-\$79,999
 \$40,000-\$49,999 \$80,000-\$89,999
 \$50,000-\$59,999 \$90,000 +
5. What is your age group?
 20-29 50-59
 30-39 60-69
 40-49 70 +
6. How long have you been a woodworker?
 0 - 2 Years 8 - 20 Years
 2 - 8 Years 20+ Years
7. How would you rank your woodworking skills?
 Simple Advanced
 Intermediate Master Craftsman
8. What stationary woodworking tools do you own? Check all that apply.
 Air Compressor Panel Saw
 Band Saw Shaper
 Drill Press Power Feeder
 Drum Sander Radial Arm Saw
 Dust Collector Planer
 Horizontal Boring Machine Spindle Sander
 Jointer Table Saw
 Lathe Vacuum Veneer Press
 Mortiser Wide Belt Sander
 Other _____
9. How many of your woodworking machines are Grizzly? _____
10. Which benchtop tools do you own? Check all that apply.
 1" x 42" Belt Sander 6" - 8" Grinder
 5" - 8" Drill Press Mini Lathe
 8" Table Saw 10" - 12" Thickness Planer
 8" - 10" Bandsaw Scroll Saw
 Disc/Belt Sander Spindle/Belt Sander
 Mini Jointer
 Other _____
11. How many of the machines checked above are Grizzly? _____
12. Which portable/hand held power tools do you own? Check all that apply.
 Belt Sander Orbital Sander
 Biscuit Joiner Palm Sander
 Circular Saw Portable Planer
 Detail Sander Saber Saw
 Drill/Driver Reciprocating Saw
 Miter Saw Router
 Other _____
13. What machines/supplies would you like Grizzly Industrial to carry?

14. What new accessories would you like Grizzly Industrial to carry?

15. What other companies do you purchase your tools and supplies from?

16. Do you think your purchase represents good value?
 Yes No
17. Would you recommend Grizzly Industrial to a friend?
 Yes No
18. Would you allow us to use your name as a reference for Grizzly customers in your area? **Note: We never use names more than three times.**
 Yes No
19. Comments: _____

CUT ALONG DOTTED LINE

FOLD ALONG DOTTED LINE



Place
Stamp
Here



GRIZZLY INDUSTRIAL, INC.
P.O. BOX 2069
BELLINGHAM, WA 98227-2069



FOLD ALONG DOTTED LINE

Send a Grizzly Catalog to a friend:

Name _____
Street _____
City _____ State _____ Zip _____

TAPE ALONG EDGES--PLEASE DO NOT STAPLE

