

Grizzly **Industrial, Inc.**®

MODEL G1066R/G1066Z/G1079R DRUM SANDER OWNER'S MANUAL *(For models manufactured since 02/11)*



Model G1066R



Model G1079R



Model G1066Z

COPYRIGHT © MAY, 2002 BY GRIZZLY INDUSTRIAL, INC. REVISED OCTOBER, 2018 (ES)
**WARNING: NO PORTION OF THIS MANUAL MAY BE REPRODUCED IN ANY SHAPE
OR FORM WITHOUT THE WRITTEN APPROVAL OF GRIZZLY INDUSTRIAL, INC.**

#0443 PRINTED IN TAIWAN

V2.10.18



WARNING!

This manual provides critical safety instructions on the proper setup, operation, maintenance, and service of this machine/tool. Save this document, refer to it often, and use it to instruct other operators.

Failure to read, understand and follow the instructions in this manual may result in fire or serious personal injury—including amputation, electrocution, or death.

The owner of this machine/tool is solely responsible for its safe use. This responsibility includes but is not limited to proper installation in a safe environment, personnel training and usage authorization, proper inspection and maintenance, manual availability and comprehension, application of safety devices, cutting/sanding/grinding tool integrity, and the usage of personal protective equipment.

The manufacturer will not be held liable for injury or property damage from negligence, improper training, machine modifications or misuse.



WARNING!

Some dust created by power sanding, sawing, grinding, drilling, and other construction activities contains chemicals known to the State of California to cause cancer, birth defects or other reproductive harm. Some examples of these chemicals are:

- **Lead from lead-based paints.**
- **Crystalline silica from bricks, cement and other masonry products.**
- **Arsenic and chromium from chemically-treated lumber.**

Your risk from these exposures varies, depending on how often you do this type of work. To reduce your exposure to these chemicals: Work in a well ventilated area, and work with approved safety equipment, such as those dust masks that are specially designed to filter out microscopic particles.

Table of Contents

INTRODUCTION	2	SECTION 5: ACCESSORIES	35
Contact Info.....	2	SECTION 6: MAINTENANCE	37
Machine Differences.....	2	Schedule.....	37
Manual Accuracy.....	2	Cleaning.....	37
Identification (G1066R).....	3	Lubrication.....	37
Identification (G1066Z).....	4	SECTION 7: SERVICE	38
Identification (G1079R).....	5	Troubleshooting.....	38
Controls & Components.....	6	Aligning Drums.....	40
Machine Data Sheet (G1066R).....	9	Adjusting Pressure Rollers.....	42
Machine Data Sheet (G1066Z).....	11	Adjusting Conveyor Belt Tension.....	43
Machine Data Sheet (G1079R).....	13	Adjusting Dust Scoop.....	44
SECTION 1: SAFETY	15	Tensioning/Replacing V-Belts.....	45
Safety Instructions for Machinery.....	15	Replacing Bearings.....	47
Additional Safety for Drum Sanders.....	17	SECTION 8: WIRING	48
SECTION 2: POWER SUPPLY	18	Wiring Safety Instructions.....	48
SECTION 3: SETUP	20	G1066R Electrical Components.....	49
Needed for Setup.....	20	G1066R Wiring Diagram.....	50
Unpacking.....	20	G1066Z Electrical Components.....	51
Inventory.....	21	G1066Z Wiring Diagram.....	52
Site Considerations.....	21	G1079R Electrical Components.....	53
Lifting & Placing.....	22	G1079R Wiring Diagram.....	54
Anchoring to Floor (G1079R).....	22	SECTION 9: PARTS	55
Assembly.....	23	G1066R Stand & Table Elevation.....	55
Dust Collection.....	24	G1066R Conveyor Belt & Table.....	56
Test Run.....	25	G1066R Drum & Roller Mechanism.....	57
Recommended Adjustments.....	26	G1066Z Stand & Table Elevation.....	60
Tightening Belts.....	26	G1066Z Conveyor Belt & Table.....	61
Disabling & Locking Switch (G1079R).....	27	G1066Z Drum & Roller Mechanism.....	62
SECTION 4: OPERATIONS	28	G1079R Stand & Table Elevation.....	65
Operation Overview.....	28	G1079R Conveyor Belt & Table.....	66
Stock Inspection and Requirements.....	29	G1079R Drum & Roller Mechanism.....	67
Choosing Sandpaper.....	29	WARRANTY & RETURNS	73
Sanding Tips.....	30		
Sanding.....	31		
Setting Depth of Cut.....	31		
Setting Conveyor Speed (G1066Z).....	32		
Monitoring Sanding Load (G1066Z).....	32		
Installing/Replacing Sandpaper (G1066R/ G1079R).....	33		
Installing/Replacing Sandpaper (G1066Z)...	34		

INTRODUCTION

Contact Info

We stand behind our machines! If you have questions or need help, contact us with the information below. Before contacting, make sure you get the **serial number** and **manufacture date** from the machine ID label. This will help us help you faster.

Grizzly Technical Support
1815 W. Battlefield
Springfield, MO 65807
Phone: (570) 546-9663
Email: techsupport@grizzly.com

We want your feedback on this manual. What did you like about it? Where could it be improved? Please take a few minutes to give us feedback.

Grizzly Documentation Manager
P.O. Box 2069
Bellingham, WA 98227-2069
Email: manuals@grizzly.com

Machine Differences

Models G1066R, G1066Z, and G1079R are heavy-duty drum sanders with the following differences:

- **Model G1066R** is a 5 HP, 24" drum sander.
- **Model G1066Z** is a 5 HP, 24" drum sander with a variable-speed conveyor and rear drum height micro-adjustment knobs.
- **Model G1079R** is a 2 HP, 16" drum sander.

Manual Accuracy

We are proud to provide a high-quality owner's manual with your new machine!

We made every effort to be exact with the instructions, specifications, drawings, and photographs in this manual. Sometimes we make mistakes, but our policy of continuous improvement also means that **sometimes the machine you receive is slightly different than shown in the manual.**

If you find this to be the case, and the difference between the manual and machine leaves you confused or unsure about something, check our website for an updated version. We post current manuals and manual updates for free on our website at www.grizzly.com.

Alternatively, you can call our Technical Support for help. Before calling, make sure you write down the **manufacture date** and **serial number** from the machine ID label (see below). This information is required for us to provide proper tech support, and it helps us determine if updated documentation is available for your machine.

Grizzly Industrial MODEL GXXXX
MACHINE NAME

SPECIFICATIONS	WARNING!
Motor: _____	To reduce risk of serious injury when using this machine:
Specification: _____	1. Read manual before operation.
Specification: _____	2. Wear safety glasses and respirator.
Specification: _____	3. Make sure machine is properly adjusted/setup and
Weight: _____	4. Make sure the motor has stopped and disconnect
	power is connected to grounded circuit before starting.
	5. DO NOT expose to rain or dampness.
	6. DO NOT modify this machine in any way.
	7. _____
	8. _____
	9. _____
	10. Maintain machine carefully to prevent accidents.

Manufacture Date: _____
Serial Number: _____

Manufactured for Grizzly in Taiwan



Identification (G1066R)

Become familiar with the names and locations of the controls and features shown below to better understand the instructions in this manual.

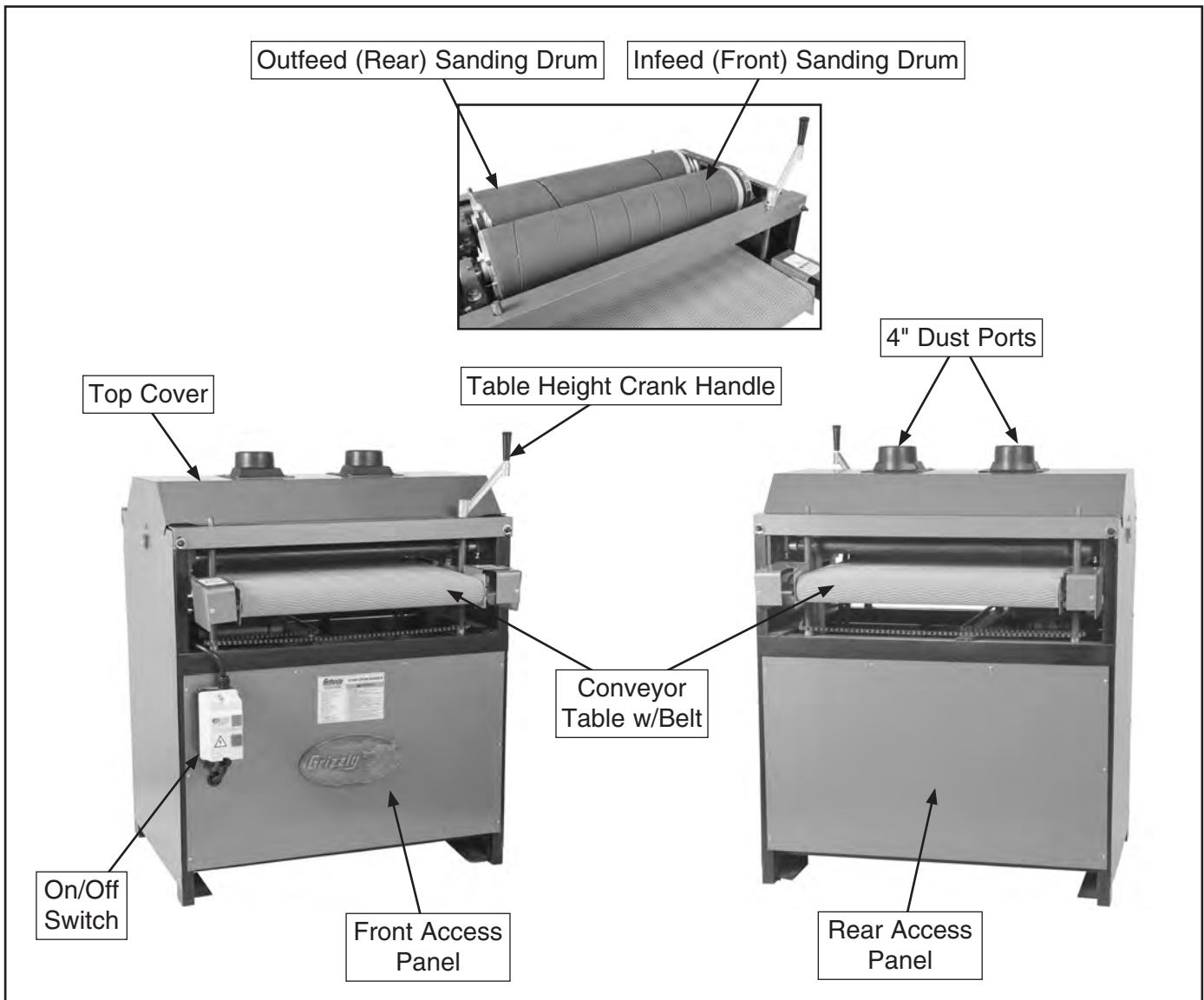

	<p>⚠ WARNING To reduce your risk of serious injury, read this entire manual BEFORE using machine.</p>
--	---



Identification (G1066Z)

Become familiar with the names and locations of the controls and features shown below to better understand the instructions in this manual.

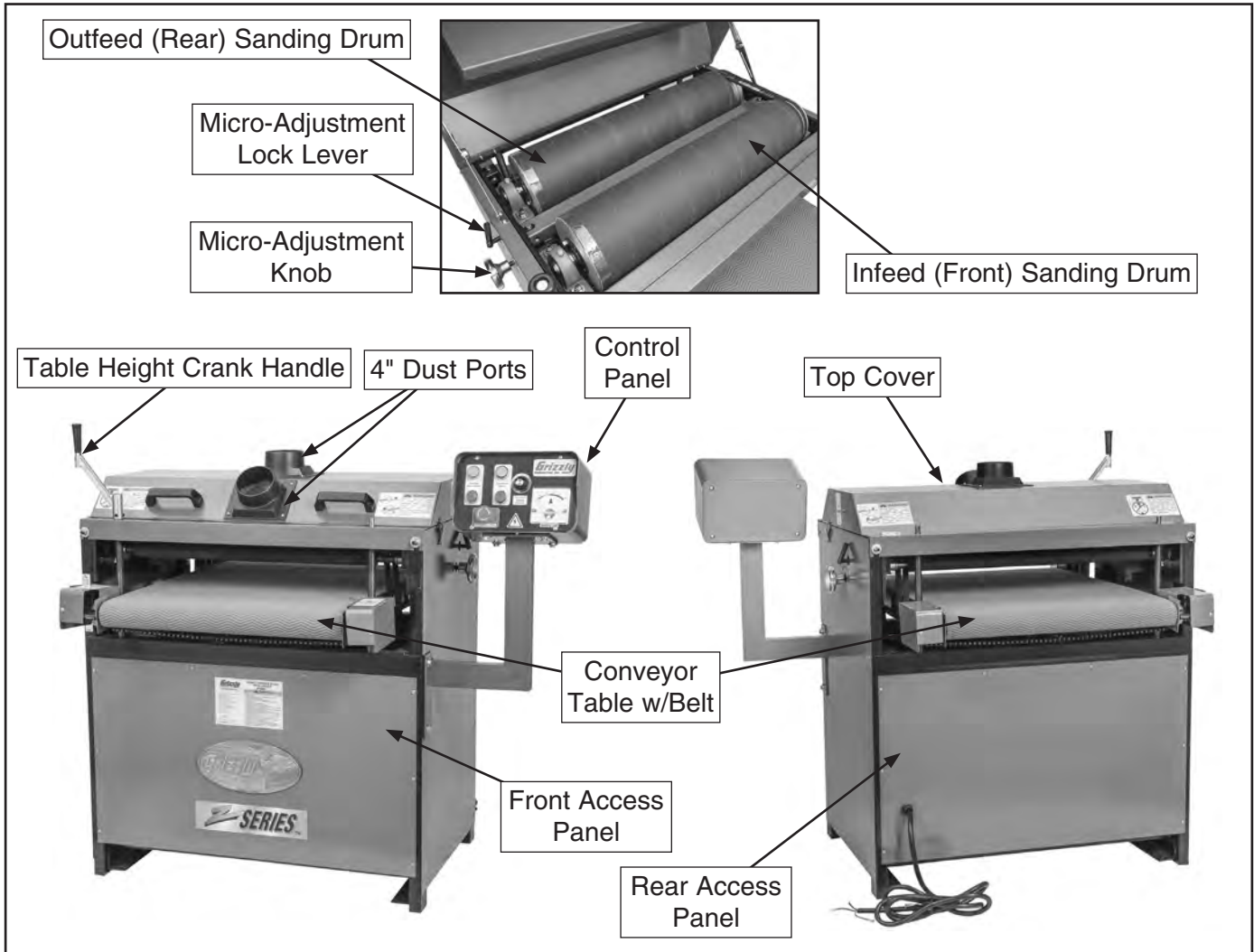

⚠ WARNING
To reduce your risk of serious injury, read this entire manual **BEFORE** using machine.



Identification (G1079R)

Become familiar with the names and locations of the controls and features shown below to better understand the instructions in this manual.

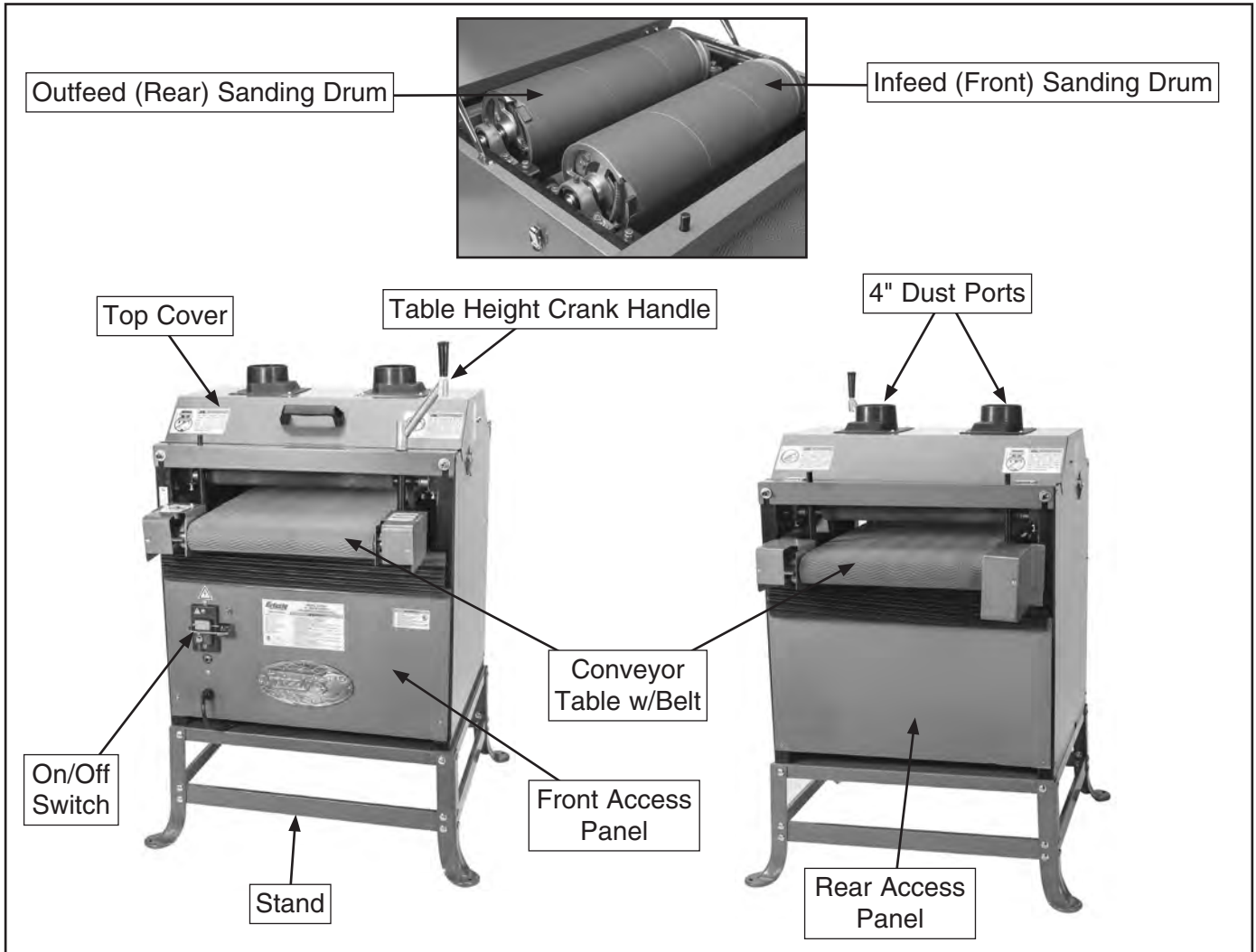

	<p>⚠ WARNING To reduce your risk of serious injury, read this entire manual BEFORE using machine.</p>
--	---



Controls & Components



G1066R

Refer to **Figures 1–3** and the following descriptions to become familiar with the basic controls and components of the Model G1066R. Understanding these items and how they work will help you understand the rest of the manual and stay safe when operating this machine.

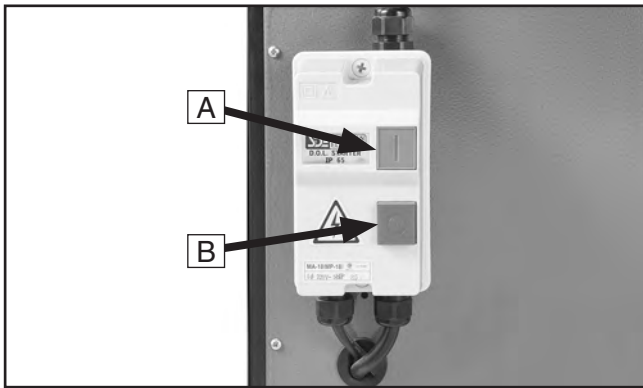

Figure 1. G1066R—ON/OFF controls.

- A. ON Button:** Push to start motor.
- B. OFF Button:** Push to stop motor.

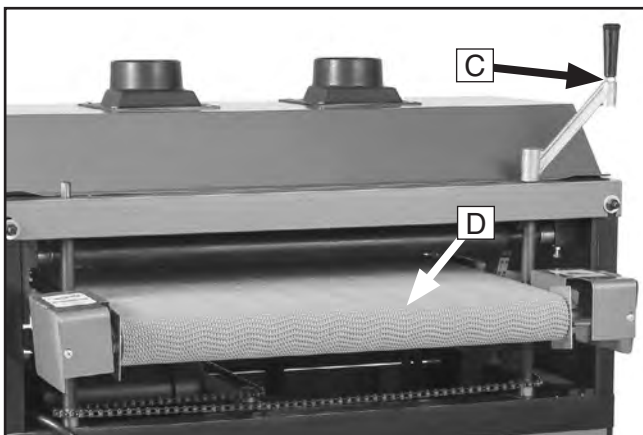

Figure 2. G1066R—front controls.

- C. Table Height Crank Handle:** Rotate to raise or lower conveyor table according to workpiece thickness.
- D. Conveyor Table w/Belt (Infeed End):** Height-adjustable table with conveyor belt that feeds workpieces toward sanding drums.

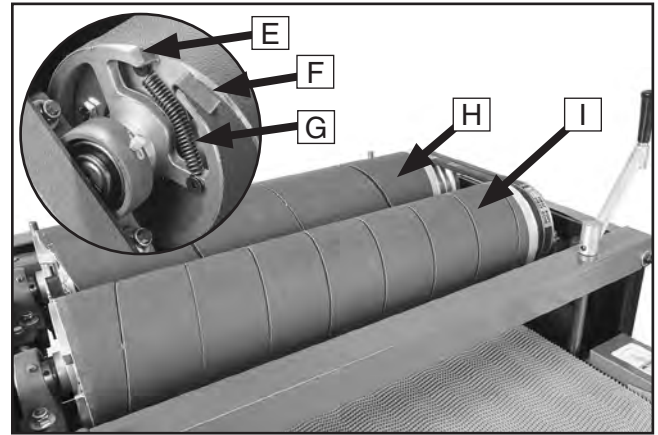

Figure 3. G1066R—drum components.

- E. Tension Wheel:** Tensioned anchor point for end of sandpaper roll.
- F. Sanding Paper Clip:** Secures end of sandpaper roll to tension wheel.
- G. Tension Spring:** Supplies tension between sanding drum and tension wheel.
- H. Outfeed (Rear) Sanding Drum:** Cylindrical drum with machined surface that is covered in felt. Typically wrapped with fine grit sandpaper to perform finish sanding portion of operation.
- I. Infeed (Front) Sanding Drum:** Cylindrical drum with machined surface. Typically wrapped with coarse grit sandpaper to perform thickness sanding portion of operation.



G1066Z

Refer to **Figures 4–6** and the following descriptions to become familiar with the basic controls and components of the Model G1066Z. Understanding these items and how they work will help you understand the rest of the manual and stay safe when operating this machine.

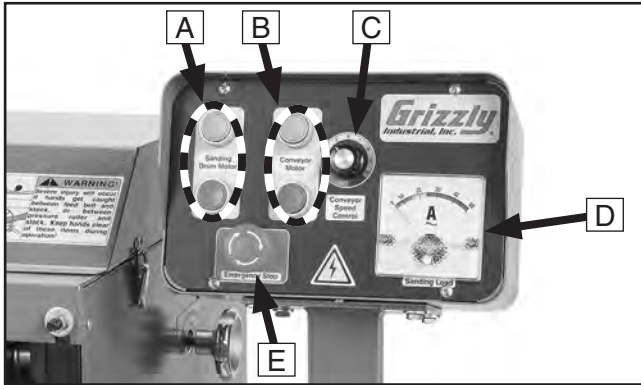

Figure 4. G1066Z—control panel.

- A. Sanding Motor ON/OFF Buttons:** Push to start/stop sanding motor.
- B. Conveyor Motor ON/OFF Buttons:** Push to start/stop conveyor motor.
- C. Conveyor Speed Control:** Turn to set conveyor belt speed between 0–10 (0–60 RPM).
- D. Load Meter:** Displays total amp draw of sanding motor.
- E. Emergency Stop Button:** Stops motors when pressed and disables ON buttons. Remains in depressed position until manually reset. Reset by twisting button clockwise until it springs outward.

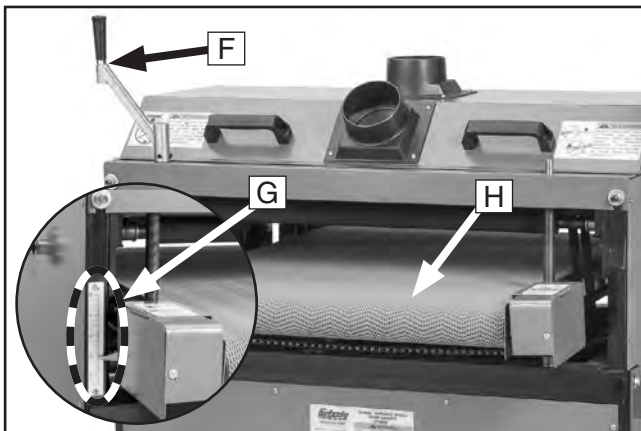

Figure 5. G1066Z—front controls.

- F. Table Height Crank Handle:** Rotate to raise or lower conveyor table according to workpiece thickness.
- G. Depth-of-Cut Scale:** Indicates distance between conveyor table and sanding drums.
- H. Conveyor Table w/Belt (Infeed End):** Height-adjustable table with conveyor belt that feeds workpieces toward sanding drums.

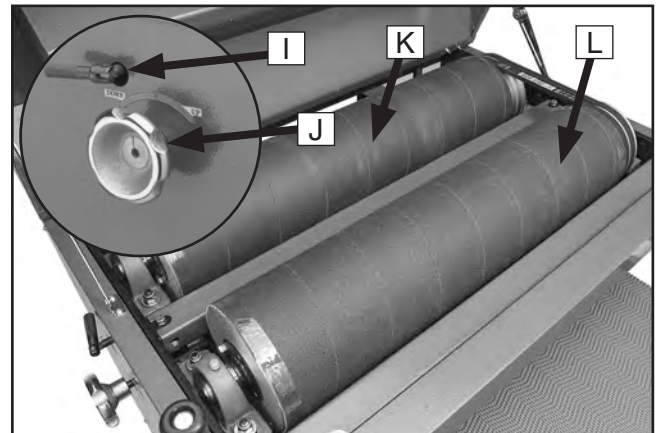

Figure 6. G1066Z—drum components.

- I. Micro-Adjustment Lock Lever (1 of 2):** Tighten to lock micro-adjustment knob in place.
- J. Micro-Adjustment Knob (1 of 2):** Rotate to make fine height adjustments of outfeed (rear) sanding drum.
- K. Outfeed (Rear) Sanding Drum:** Cylindrical drum with machined surface that is covered in hook-and-loop material. Typically wrapped with fine grit sandpaper to perform finish sanding portion of operation.
- L. Infeed (Front) Sanding Drum:** Cylindrical drum with machined surface that is covered in hook-and-loop material. Typically wrapped with coarse grit sandpaper to perform thickness sanding portion of operation.



G1079R

Refer to **Figures 7–9** and the following descriptions to become familiar with the basic controls and components of the Model G1079R. Understanding these items and how they work will help you understand the rest of the manual and stay safe when operating this machine.

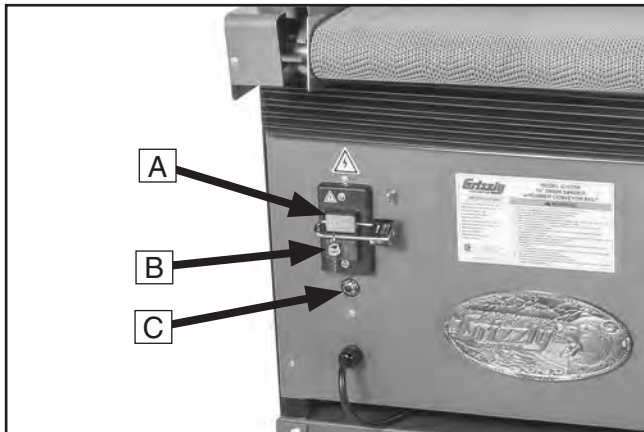

Figure 7. G1079R—ON/OFF controls.

- A. ON Button:** Push to start motor. Insert padlock through button to disable (padlock not included).
- B. OFF Button:** Push to stop motor.
- C. Circuit Breaker Reset Button:** Circuit breaker trips if motor draws excessive current and overheats. Push to reset circuit breaker after allowing machine to cool down.

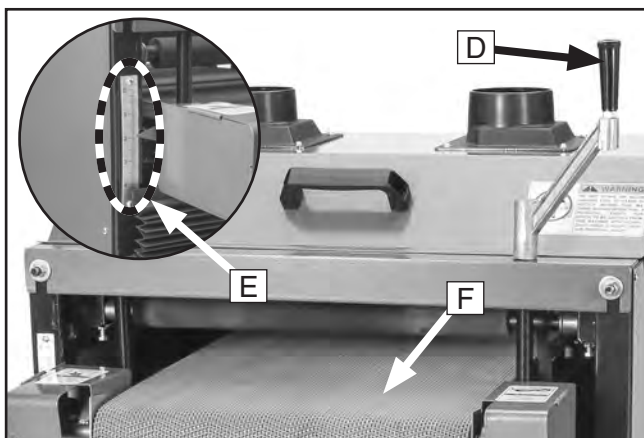

Figure 8. G1079R—front controls.

- D. Table Height Crank Handle:** Rotate to raise or lower conveyor table according to workpiece thickness.

- E. Depth-of-Cut Scale:** Indicates distance between conveyor table and sanding drums.
- F. Conveyor Table w/Belt (Infeed End):** Height-adjustable table with conveyor belt that feeds workpieces toward sanding drums.

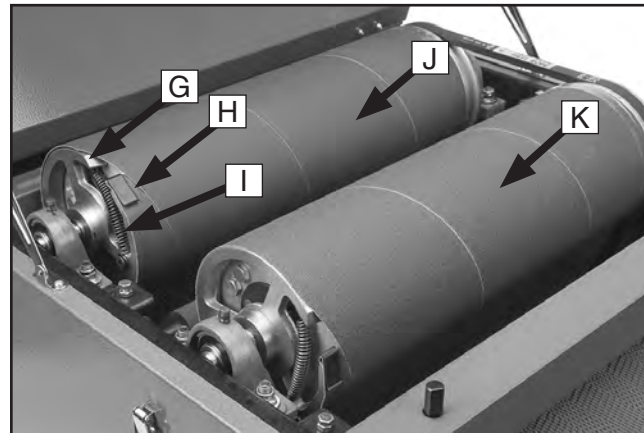

Figure 9. G1079R—drum components.

- G. Tension Wheel:** Tensioned anchor point for end of sandpaper roll.
- H. Sanding Paper Clip:** Secures end of sandpaper roll to tension wheel.
- I. Tension Spring:** Supplies tension between sanding drum and tension wheel.
- J. Outfeed (Rear) Sanding Drum:** Cylindrical drum with machined surface that is covered in felt. Typically wrapped with fine grit sandpaper to perform finish sanding portion of operation.
- K. Infeed (Front) Sanding Drum:** Cylindrical drum with machined surface. Typically wrapped with coarse grit sandpaper to perform thickness sanding portion of operation.





MACHINE DATA SHEET

Customer Service #: (570) 546-9663 · To Order Call: (800) 523-4777 · Fax #: (800) 438-5901

MODEL G1066R 24" 5 HP DRUM SANDER

Product Dimensions:

Weight..... 389 lbs.
Width (side-to-side) x Depth (front-to-back) x Height..... 37 x 34-1/2 x 43 in.
Footprint (Length x Width)..... 34-1/2 x 24 in.

Shipping Dimensions:

Type..... Cardboard Box on Metal Skids
Content..... Machine
Weight..... 442 lbs.
Length x Width x Height..... 41 x 38 x 43 in.
Must Ship Upright..... Yes

Electrical:

Power Requirement..... 220V, Single-Phase, 60 Hz
Prewired Voltage..... 220V
Full-Load Current Rating..... 26A
Minimum Circuit Size..... 30A
Connection Type..... Cord & Plug
Power Cord Included..... Yes
Power Cord Length..... 8 ft.
Power Cord Gauge..... 12 AWG
Plug Included..... No
Recommended Plug Type..... L6-30
Switch Type..... Magnetic Switch w/Overload Protection

Motors:

Main

Horsepower..... 5 HP
Phase..... Single-Phase
Amps..... 25A
Speed..... 3450 RPM
Type..... TEFC Capacitor-Start Induction
Power Transfer Belt Drive
Bearings..... Sealed & Permanently Lubricated
Centrifugal Switch/Contacts Type..... External

Feed

Horsepower..... 1/4 HP
Phase..... Single-Phase
Amps..... 1A
Speed..... 30 RPM
Type..... TEFC Capacitor-Start Induction
Power Transfer Chain Drive
Bearings..... Sealed & Permanently Lubricated
Centrifugal Switch/Contacts Type..... N/A



Main Specifications:

Operation Information

Number of Sanding Heads.....	2
Maximum Board Width.....	23-1/2 in.
Minimum Board Width.....	2 in.
Maximum Board Thickness.....	4 in.
Minimum Board Thickness.....	1/8 in.
Minimum Board Length.....	9 in.
Sandpaper Speed.....	2300 FPM
Conveyor Feed Rate.....	11 FPM
Sandpaper Length.....	95-1/2
Sandpaper Width.....	6 in.

Drum Information

Infeed Sanding Drum Type.....	Aluminum
Infeed Sanding Drum Size.....	6 in.
Outfeed Sanding Drum Type.....	Aluminum
Outfeed Sanding Drum Size.....	6 in.

Construction

Conveyor Belt.....	Rubber
Body.....	Steel
Paint Type/Finish.....	Powder Coated

Other Related Information

Floor To Table Height.....	31 in.
Sanding Belt Tension.....	Spring Loaded
Number of Pressure Rollers.....	3
Pressure Roller Type.....	Rubber
Pressure Roller Size.....	1-5/8 in.
Conveyor Belt Length.....	74 in.
Conveyor Belt Width.....	24 in.
Belt Roller Size.....	1-7/8 in.
Number of Dust Ports.....	2
Dust Port Size.....	4 in.
Mobile Base.....	D2058A, D2246A

Other Specifications:

Country of Origin	Taiwan
Warranty	1 Year
Approximate Assembly & Setup Time	30 Minutes
Serial Number Location	ID Label on Center of the Stand

Features:

- Spring-Loaded Sanding Belt Tension/Sandpaper
- Industrial-Duty Rubber Conveyor Belt
- Two 4" Dust Ports
- 11 FPM Conveyor Speed
- V-Belt Main Motor; Chain Drive Feed Motor
- Dual 6" Aluminum Sanding Drums
- Green Powder Coated Paint
- Computer Balanced Drums
- Four Leadscrew Table Lifting and Lowering System





MACHINE DATA SHEET

Customer Service #: (570) 546-9663 · To Order Call: (800) 523-4777 · Fax #: (800) 438-5901

MODEL G1066Z 24" 5 HP DRUM SANDER W/ VS

Product Dimensions:

Weight..... 389 lbs.
Width (side-to-side) x Depth (front-to-back) x Height..... 50 x 37 x 44-1/2 in.
Footprint (Length x Width)..... 34-1/2 x 24 in.

Shipping Dimensions:

Type..... Cardboard Box on Metal Skids
Content..... Machine
Weight..... 489 lbs.
Length x Width x Height..... 41 x 38 x 43 in.
Must Ship Upright..... Yes

Electrical:

Power Requirement..... 220V, Single-Phase, 60 Hz
Prewired Voltage..... 220V
Full-Load Current Rating..... 27A
Minimum Circuit Size..... 30A
Connection Type..... Cord & Plug
Power Cord Included..... Yes
Power Cord Length..... 8 ft.
Power Cord Gauge..... 12 AWG
Plug Included..... No
Recommended Plug Type..... L6-30
Switch Type..... Control Panel w/Magnetic Switch Protection

Motors:

Main

Horsepower..... 5 HP
Phase..... Single-Phase
Amps..... 25A
Speed..... 3450 RPM
Type..... TEFC Capacitor-Start Induction
Power Transfer Twin V-Belt Drive
Bearings..... Sealed & Permanently Lubricated
Centrifugal Switch/Contacts Type..... External

Feed

Horsepower..... 1/3 HP
Phase..... Single-Phase
Amps..... 2A
Speed..... 60 RPM
Type..... Universal
Power Transfer Chain Drive
Bearings..... Sealed & Permanently Lubricated
Centrifugal Switch/Contacts Type..... N/A



Main Specifications:

Operation Information

Number of Sanding Heads.....	2
Maximum Board Width.....	23-1/2 in.
Minimum Board Width.....	2 in.
Maximum Board Thickness.....	4 in.
Minimum Board Thickness.....	1/8 in.
Minimum Board Length.....	9 in.
Sandpaper Speed.....	2300 FPM
Conveyor Feed Rate.....	0 – 20 FPM
Sandpaper Length.....	176 in.
Sandpaper Width.....	3 in.

Drum Information

Infeed Sanding Drum Type.....	Aluminum
Infeed Sanding Drum Size.....	6 in.
Outfeed Sanding Drum Type.....	Aluminum
Outfeed Sanding Drum Size.....	6 in.

Construction

Conveyor Belt.....	Rubber
Body.....	Steel
Paint Type/Finish.....	Powder Coated

Other Related Information

Floor To Table Height.....	33 in.
Sanding Belt Tension.....	Hook & Loop
Number of Pressure Rollers.....	3
Pressure Roller Type.....	Rubber
Pressure Roller Size.....	1-5/8 in.
Conveyor Belt Length.....	74 in.
Conveyor Belt Width.....	24 in.
Belt Roller Size.....	1-7/8 in.
Number of Dust Ports.....	2
Dust Port Size.....	4 in.
Mobile Base.....	D2058A, D2246A

Other Specifications:

Country of Origin	Taiwan
Warranty	1 Year
Approximate Assembly & Setup Time	30 Minutes
Serial Number Location	ID Label on Center of the Stand

Features:

- Hook and Loop Sanding Belt Tension/Sandpaper
- Industrial-Duty Rubber Conveyor Belt
- Two 4" Dust Ports
- Variable Speed Conveyor
- V-Belt Main Motor; Chain Drive Feed Motor
- Dual 6" Aluminum Sanding Drums
- Green Powder Coated Paint
- Computer Balanced Drums
- Four Leadscrew Table Lifting and Lowering System
- Easy Access Control Panel with Amp Load Meter
- External Micro-Adjustment on Outfeed Drum





MACHINE DATA SHEET

Customer Service #: (570) 546-9663 · To Order Call: (800) 523-4777 · Fax #: (800) 438-5901

MODEL G1079R 16" 2 HP DRUM SANDER W/ RUBBER CONVEYOR

Product Dimensions:

Weight..... 283 lbs.
Width (side-to-side) x Depth (front-to-back) x Height..... 27 x 36-1/2 x 42-1/2 in.
Footprint (Length x Width)..... 32 x 29 in.

Shipping Dimensions:

Type..... Cardboard Box
Content..... Machine
Weight..... 304 lbs.
Length x Width x Height..... 41 x 30 x 34 in.
Must Ship Upright..... Yes

Electrical:

Power Requirement..... 220V, Single-Phase, 60 Hz
Prewired Voltage..... 220V
Full-Load Current Rating..... 9.5A
Minimum Circuit Size..... 15A
Connection Type..... Cord & Plug
Power Cord Included..... Yes
Power Cord Length..... 8 ft.
Power Cord Gauge..... 14 AWG
Plug Included..... No
Recommended Plug Type..... 6-15
Switch Type..... Paddle Safety Switch w/Removable Key

Motors:

Main

Horsepower..... 2 HP
Phase..... Single-Phase
Amps..... 8.5A
Speed..... 3450 RPM
Type..... TEFC Capacitor-Start Induction
Power Transfer V-Belt Drive
Bearings..... Sealed & Permanently Lubricated
Centrifugal Switch/Contacts Type..... External

Feed

Horsepower..... 1/4 HP
Phase..... Single-Phase
Amps..... 1A
Speed..... 30 RPM
Type..... TEFC Capacitor-Start Induction
Power Transfer Chain Drive
Bearings..... Sealed & Permanently Lubricated
Centrifugal Switch/Contacts Type..... N/A



Main Specifications:

Operation Information

Number of Sanding Heads.....	2
Maximum Board Width.....	15-3/8 in.
Minimum Board Width.....	2 in.
Maximum Board Thickness.....	3-1/2 in.
Minimum Board Thickness.....	1/4 in.
Minimum Board Length.....	9 in.
Sandpaper Speed.....	2300 FPM
Conveyor Feed Rate.....	11 FPM
Sandpaper Length.....	74 in. (Front), 75 in. (Rear)
Sandpaper Width.....	6 in.

Drum Information

Infeed Sanding Drum Type.....	Aluminum
Infeed Sanding Drum Size.....	6 in.
Outfeed Sanding Drum Type.....	Aluminum
Outfeed Sanding Drum Size.....	6 in.

Construction

Conveyor Belt.....	Rubber
Body.....	Steel
Base.....	Steel
Paint Type/Finish.....	Powder Coated

Other Related Information

Floor To Table Height.....	34 in.
Sanding Belt Tension.....	Spring Loaded
Number of Pressure Rollers.....	3
Pressure Roller Type.....	Rubber
Pressure Roller Size.....	1-5/8 in.
Conveyor Belt Length.....	73 in.
Conveyor Belt Width.....	16 in.
Belt Roller Size.....	1-7/8 in.
Number of Dust Ports.....	2
Dust Port Size.....	4 in.
Mobile Base.....	D2058A, D2246A

Other Specifications:

Country of Origin	Taiwan
Warranty	1 Year
Approximate Assembly & Setup Time	30 Minutes
Serial Number Location	ID Label on Center of the Stand
Certified by a Nationally Recognized Testing Laboratory (NRTL)	Yes

Features:

- Spring-Loaded Sanding Belt Tension/Sandpaper
- Industrial-Duty Rubber Conveyor Belt
- Two 4" Dust Ports
- 11 FPM Conveyor Speed
- V-Belt Main Motor; Chain Drive Feed Motor
- Dual 6" Aluminum Sanding Drums
- Green Powder Coated Paint
- Computer-Balanced, Non-Rubberized Drums
- Includes Stand
- Four Leadscrew Table Lifting and Lowering System



SECTION 1: SAFETY

For Your Own Safety, Read Instruction Manual Before Operating This Machine

The purpose of safety symbols is to attract your attention to possible hazardous conditions. This manual uses a series of symbols and signal words intended to convey the level of importance of the safety messages. The progression of symbols is described below. Remember that safety messages by themselves do not eliminate danger and are not a substitute for proper accident prevention measures. Always use common sense and good judgment.



Indicates an imminently hazardous situation which, if not avoided, **WILL** result in death or serious injury.



Indicates a potentially hazardous situation which, if not avoided, **COULD** result in death or serious injury.



Indicates a potentially hazardous situation which, if not avoided, **MAY** result in minor or moderate injury. It may also be used to alert against unsafe practices.

NOTICE

Alerts the user to useful information about proper operation of the machine to avoid machine damage.

Safety Instructions for Machinery

WARNING

OWNER'S MANUAL. Read and understand this owner's manual **BEFORE** using machine.

TRAINED OPERATORS ONLY. Untrained operators have a higher risk of being hurt or killed. Only allow trained/supervised people to use this machine. When machine is not being used, disconnect power, remove switch keys, or lock-out machine to prevent unauthorized use—especially around children. Make your workshop kid proof!

DANGEROUS ENVIRONMENTS. Do not use machinery in areas that are wet, cluttered, or have poor lighting. Operating machinery in these areas greatly increases the risk of accidents and injury.

MENTAL ALERTNESS REQUIRED. Full mental alertness is required for safe operation of machinery. Never operate under the influence of drugs or alcohol, when tired, or when distracted.

ELECTRICAL EQUIPMENT INJURY RISKS. You can be shocked, burned, or killed by touching live electrical components or improperly grounded machinery. To reduce this risk, only allow qualified service personnel to do electrical installation or repair work, and always disconnect power before accessing or exposing electrical equipment.

DISCONNECT POWER FIRST. Always disconnect machine from power supply **BEFORE** making adjustments, changing tooling, or servicing machine. This prevents an injury risk from unintended startup or contact with live electrical components.

EYE PROTECTION. Always wear ANSI-approved safety glasses or a face shield when operating or observing machinery to reduce the risk of eye injury or blindness from flying particles. Everyday eyeglasses are **NOT** approved safety glasses.



WARNING

WEARING PROPER APPAREL. Do not wear clothing, apparel or jewelry that can become entangled in moving parts. Always tie back or cover long hair. Wear non-slip footwear to reduce risk of slipping and losing control or accidentally contacting cutting tool or moving parts.

HAZARDOUS DUST. Dust created by machinery operations may cause cancer, birth defects, or long-term respiratory damage. Be aware of dust hazards associated with each workpiece material. Always wear a NIOSH-approved respirator to reduce your risk.

HEARING PROTECTION. Always wear hearing protection when operating or observing loud machinery. Extended exposure to this noise without hearing protection can cause permanent hearing loss.

REMOVE ADJUSTING TOOLS. Tools left on machinery can become dangerous projectiles upon startup. Never leave chuck keys, wrenches, or any other tools on machine. Always verify removal before starting!

USE CORRECT TOOL FOR THE JOB. Only use this tool for its intended purpose—do not force it or an attachment to do a job for which it was not designed. Never make unapproved modifications—modifying tool or using it differently than intended may result in malfunction or mechanical failure that can lead to personal injury or death!

AWKWARD POSITIONS. Keep proper footing and balance at all times when operating machine. Do not overreach! Avoid awkward hand positions that make workpiece control difficult or increase the risk of accidental injury.

CHILDREN & BYSTANDERS. Keep children and bystanders at a safe distance from the work area. Stop using machine if they become a distraction.

GUARDS & COVERS. Guards and covers reduce accidental contact with moving parts or flying debris. Make sure they are properly installed, undamaged, and working correctly **BEFORE** operating machine.

FORCING MACHINERY. Do not force machine. It will do the job safer and better at the rate for which it was designed.

NEVER STAND ON MACHINE. Serious injury may occur if machine is tipped or if the cutting tool is unintentionally contacted.

STABLE MACHINE. Unexpected movement during operation greatly increases risk of injury or loss of control. Before starting, verify machine is stable and mobile base (if used) is locked.

USE RECOMMENDED ACCESSORIES. Consult this owner's manual or the manufacturer for recommended accessories. Using improper accessories will increase the risk of serious injury.

UNATTENDED OPERATION. To reduce the risk of accidental injury, turn machine **OFF** and ensure all moving parts completely stop before walking away. Never leave machine running while unattended.

MAINTAIN WITH CARE. Follow all maintenance instructions and lubrication schedules to keep machine in good working condition. A machine that is improperly maintained could malfunction, leading to serious personal injury or death.

DAMAGED PARTS. Regularly inspect machine for damaged, loose, or mis-adjusted parts—or any condition that could affect safe operation. Immediately repair/replace **BEFORE** operating machine. For your own safety, **DO NOT** operate machine with damaged parts!

MAINTAIN POWER CORDS. When disconnecting cord-connected machines from power, grab and pull the plug—**NOT** the cord. Pulling the cord may damage the wires inside. Do not handle cord/plug with wet hands. Avoid cord damage by keeping it away from heated surfaces, high traffic areas, harsh chemicals, and wet/damp locations.

EXPERIENCING DIFFICULTIES. If at any time you experience difficulties performing the intended operation, stop using the machine! Contact our Technical Support at (570) 546-9663.



Additional Safety for Drum Sanders

WARNING

Serious injury or death can occur from getting hands trapped between workpiece and conveyor table and being pulled into machine, or becoming entangled in rotating parts inside machine. Workpieces thrown by sander can strike nearby operator or bystanders with significant force. Long-term respiratory damage can occur from using sander without proper use of a respirator. To reduce the risk of these hazards, operator and bystanders **MUST** completely heed the hazards and warnings below.

FEEDING WORKPIECE. Placing fingers between workpiece and conveyor can result in pinching injuries, or possibly getting trapped and pulled into sanding area of machine. **DO NOT** place fingers under bottom of workpiece while feeding it into sander.

SANDING DUST. Sanding creates large amounts of fine airborne dust that can lead to eye injury or serious respiratory illness. Reduce your risk by always wearing approved eye and respiratory protection when sanding. Never operate without adequate dust collection system in place and running. However, dust collection is not a substitute for using a respirator.

POWER DISCONNECT. An accidental startup while changing sanding belts or performing adjustments or maintenance can result in serious entanglement or abrasion injuries. Make sure machine is turned **OFF**, disconnected from power and air, and all moving parts are completely stopped before changing belts, doing adjustments, or performing maintenance.

SANDPAPER CONTACT. Rotating sandpaper can remove a large amount of flesh quickly. Keep hands away from rotating sanding drum(s) during operation. Never touch moving sandpaper.

AVOIDING ENTANGLEMENT. Tie back long hair, remove jewelry, and do not wear loose clothing or gloves. These can easily get caught in moving parts. Never reach inside machine or try to clear jammed workpiece while machine is operating. Keep all guards in place and secure.

WORKPIECE MATERIAL. This sander is designed to sand only natural wood products or man-made products made from natural wood fiber. **DO NOT** sand any metal products.

WORKPIECE INSPECTION. Nails, staples, knots, or other imperfections in workpiece can be dislodged and thrown from sander at high rate of speed into operator or bystanders, or cause damage to sandpaper or sander. Never try to sand stock that has embedded foreign objects or questionable imperfections.

KICKBACK. Occurs when a workpiece is ejected out the front of sander at a high rate of speed toward operator or bystanders. To reduce risk of kickback-related injuries, always stay out of workpiece path, only feed one board at a time, and always make sure pressure rollers are properly adjusted below sanding roller. Never sand workpieces below minimum specifications listed in **Machine Data Sheet**.

WARNING

Like all machinery there is potential danger when operating this machine. Accidents are frequently caused by lack of familiarity or failure to pay attention. Use this machine with respect and caution to decrease the risk of operator injury. If normal safety precautions are overlooked or ignored, serious personal injury may occur.

WARNING

No list of safety guidelines can be complete. Every shop environment is different. Always consider safety first, as it applies to your individual working conditions. Use this and other machinery with caution and respect. Failure to do so could result in serious personal injury, damage to equipment, or poor work results.



SECTION 2: POWER SUPPLY

Availability

Before installing the machine, consider the availability and proximity of the required power supply circuit. If an existing circuit does not meet the requirements for this machine, a new circuit must be installed. To minimize the risk of electrocution, fire, or equipment damage, installation work and electrical wiring must be done by an electrician or qualified service personnel in accordance with all applicable codes and standards.

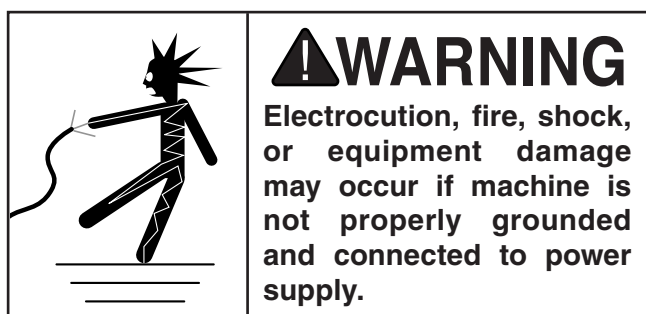

Full-Load Current Rating

The full-load current rating is the amperage a machine draws at 100% of the rated output power. On machines with multiple motors, this is the amperage drawn by the largest motor or sum of all motors and electrical devices that might operate at one time during normal operations.

G1066R Amp Draw at 220V 26 Amps
G1066Z Amp Draw at 220V..... 27 Amps
G1079R Amp Draw at 220V 9.5 Amps

The full-load current is not the maximum amount of amps that the machine will draw. If the machine is overloaded, it will draw additional amps beyond the full-load rating.

If the machine is overloaded for a sufficient length of time, damage, overheating, or fire may result—especially if connected to an undersized circuit. To reduce the risk of these hazards, avoid overloading the machine during operation and make sure it is connected to a power supply circuit that meets the specified circuit requirements.

Circuit Requirements for 220V

This machine is prewired to operate on a power supply circuit that has a verified ground and meets the following requirements:

Nominal Voltage 208V, 220V, 230V, 240V
Cycle 60 Hz
Phase Single-Phase
Power Supply Circuit (G1066R/Z)..... 30 Amps
Power Supply Circuit (G1079R) 15 Amps
Plug/Receptacle (G1066R/Z)..... NEMA L6-30
Plug/Receptacle (G1079R) NEMA 6-15
Cord (G1066R/Z)
..... "S"-Type, 3-Wire, 12 AWG, 300 VAC
Cord (G1079R) "S"-Type, 3-Wire, 14 AWG, 300

A power supply circuit includes all electrical equipment between the breaker box or fuse panel in the building and the machine. The power supply circuit used for this machine must be sized to safely handle the full-load current drawn from the machine for an extended period of time. (If this machine is connected to a circuit protected by fuses, use a time delay fuse marked D.)

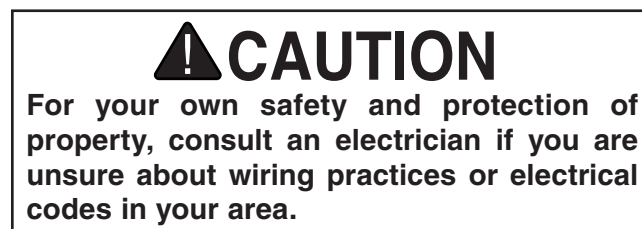

Note: *Circuit requirements in this manual apply to a dedicated circuit—where only one machine will be running on the circuit at a time. If machine will be connected to a shared circuit where multiple machines may be running at the same time, consult an electrician or qualified service personnel to ensure circuit is properly sized for safe operation.*



Grounding Instructions

This machine **MUST** be grounded. In the event of certain malfunctions or breakdowns, grounding reduces the risk of electric shock by providing a path of least resistance for electric current.

The power cord and plug specified under “Circuit Requirements for 220V” on the previous page has an equipment-grounding wire and a ground-ing prong. The plug must only be inserted into a matching receptacle (outlet) that is properly installed and grounded in accordance with all local codes and ordinances (see figure below).

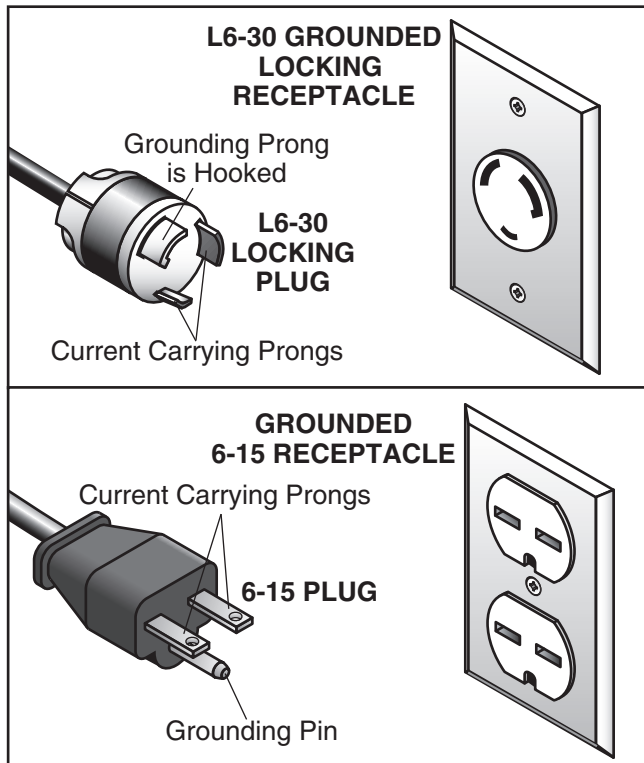
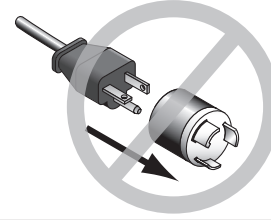

Figure 10. Typical L6-30 (G1066R, G1066Z) and 6-15 (G1079R) plugs and receptacles.

! WARNING

Serious injury could occur if you connect machine to power before completing setup process. DO NOT connect to power until instructed later in this manual.

! CAUTION



No adapter should be used with plug. If plug does not fit available receptacle, or if machine must be reconnected for use on a different type of circuit, reconnection must be performed by an electrician or qualified service personnel, and it must comply with all local codes and ordinances.

Improper connection of the equipment-grounding wire can result in a risk of electric shock. The wire with green insulation (with or without yellow stripes) is the equipment-grounding wire. If repair or replacement of the power cord or plug is necessary, do not connect the equipment-grounding wire to a live (current carrying) terminal.

Check with a qualified electrician or service personnel if you do not understand these grounding requirements, or if you are in doubt about whether the tool is properly grounded. If you ever notice that a cord or plug is damaged or worn, disconnect it from power, and immediately replace it with a new one.

Extension Cords

We do not recommend using an extension cord with this machine. If you must use an extension cord, only use it if absolutely necessary and only on a temporary basis.

Extension cords cause voltage drop, which can damage electrical components and shorten motor life. Voltage drop increases as the extension cord size gets longer and the gauge size gets smaller (higher gauge numbers indicate smaller sizes).

Any extension cord used with this machine must be in good condition and contain a ground wire and matching plug/receptacle. Additionally, it must meet the following size requirements:

Minimum Gauge Size (G1066R/Z) 12 AWG
Minimum Gauge Size (G1079R) 14 AWG
Maximum Length (Shorter is Better).....50 ft.



SECTION 3: SETUP

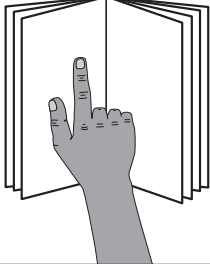

!WARNING
This machine presents serious injury hazards to untrained users. Read through this entire manual to become familiar with the controls and operations before starting the machine!



!WARNING
Wear safety glasses during the entire setup process!

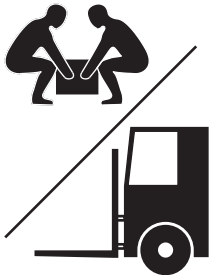

!WARNING
HEAVY LIFT!
Straining or crushing injury may occur from improperly lifting machine or some of its parts. To reduce this risk, get help from other people and use a forklift (or other lifting equipment) rated for weight of this machine.

Needed for Setup

The following items are needed, but not included, for the setup/assembly of this machine.

Description	Qty
• Additional Person	1
• Safety Glasses (for each person).....	1
• Leather Gloves (for each person).....	1 Pair
• Cleaner/Degreaser	As Needed
• Disposable Shop Rags.....	As Needed
• Lifting Equipment (Min. 600 lb. rating):	
—Forklift or Hoist	1
—Lifting Slings	2
• Precision Straightedge 4'	1
• Phillips Screwdriver #2	1
• Wrench or Socket 1/2"	1
• Double-Sided Tape.....	As Needed
• Dust-Collection System	1
• 4" Dust Hose (length as needed)	2
• 4" Hose Clamp	2

Unpacking

This machine was carefully packaged for safe transport. When unpacking, separate all enclosed items from packaging materials and inspect them for shipping damage. ***If items are damaged, please call us immediately at (570) 546-9663.***

IMPORTANT: Save all packaging materials until you are completely satisfied with the machine and have resolved any issues between Grizzly or the shipping agent. *You MUST have the original packaging to file a freight claim. It is also extremely helpful if you need to return your machine later.*



!WARNING
SUFFOCATION HAZARD!
Keep children and pets away from plastic bags or packing materials shipped with this machine.



Inventory

The following is a list of items shipped with your machine. Before beginning setup, lay these items out and inventory them.

If any non-proprietary parts are missing (e.g. a nut or a washer), we will gladly replace them; or for the sake of expediency, replacements can be obtained at your local hardware store.

NOTICE

If you cannot find an item on this list, carefully check around/inside the machine and packaging materials. Often, these items get lost in packaging materials while unpacking or they are pre-installed at the factory.

Box 1 (Figure 11)	Qty
A. Drum Sander (Not Shown)	1
B. Crank Handle	1
C. 4" Dust Ports	2
D. Self-Tapping Screws #8 x 1/2"	8
E. Flat Washers 10mm	8
F. Sandpaper Clips (G1066R, G1079R)	2
G. Control Panel (G1066Z).....	1
H. Hex Bolts 5/16"-18 x 1" (G1066Z)	2
I. Flat Washers 5/16" (G1066Z)	2
J. Front Panel (G1066Z).....	1
K. Self-Tapping Screws #8 x 3/8" (G1066Z).....	8
L. Hex Wrench 3mm.....	1

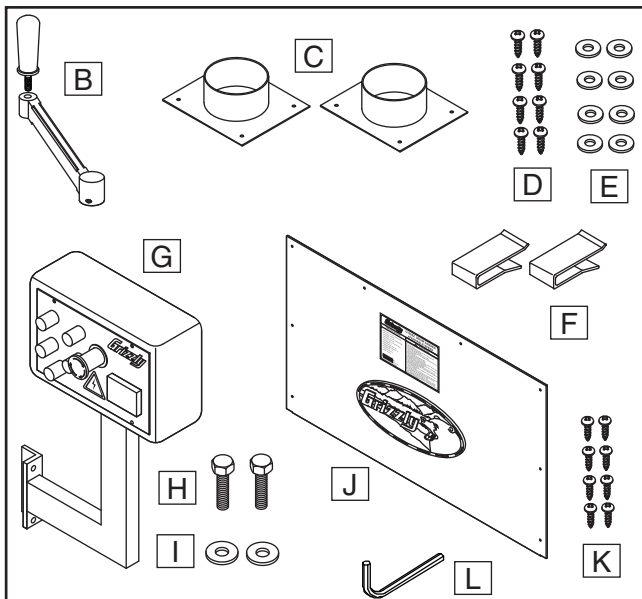

Figure 11. Inventory.



Site Considerations

Weight Load

Refer to the **Machine Data Sheet** for the weight of your machine. Make sure that the surface upon which the machine is placed will bear the weight of the machine, additional equipment that may be installed on the machine, and the heaviest workpiece that will be used. Additionally, consider the weight of the operator and any dynamic loading that may occur when operating the machine.

Space Allocation

Consider the largest size of workpiece that will be processed through this machine and provide enough space around the machine for adequate operator material handling or the installation of auxiliary equipment. With permanent installations, leave enough space around the machine to open or remove doors/covers as required by the maintenance and service described in this manual.

Physical Environment

The physical environment where the machine is operated is important for safe operation and longevity of machine components. For best results, operate this machine in a dry environment that is free from excessive moisture, hazardous chemicals, airborne abrasives, or extreme conditions. Extreme conditions for this type of machinery are generally those where the ambient temperature range exceeds 41°–104°F; the relative humidity range exceeds 20%–95% (non-condensing); or the environment is subject to vibration, shocks, or bumps.

Electrical Installation

Place this machine near an existing power source. Make sure all power cords are protected from traffic, material handling, moisture, chemicals, or other hazards. Make sure to leave enough space around machine to disconnect power supply or apply a lockout/tagout device, if required.

Lighting

Lighting around the machine must be adequate enough that operations can be performed safely. Shadows, glare, or strobe effects that may distract or impede the operator must be eliminated.

Lifting & Placing

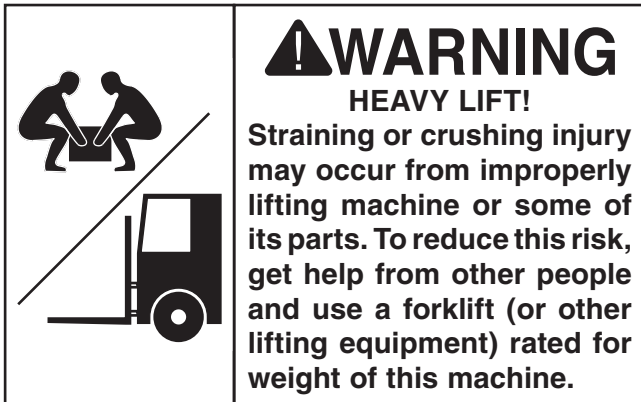

DO NOT attempt to lift or move machine without using a forklift or necessary assistance from other people.

Review the **Power Supply** section (Page 18) and **Site Considerations** section (Page 21), then prepare a permanent location for the machine.

IMPORTANT: Make sure prepared location is clean and level.

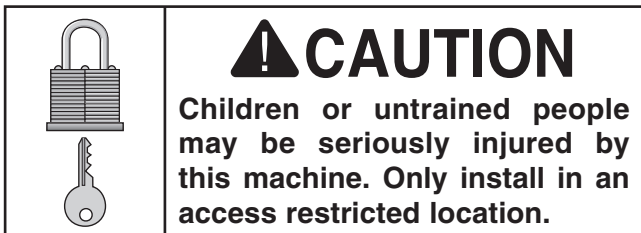

To lift and place machine:

1. Move machine near its prepared location while still inside shipping box.
2. Remove top and sides of shipping box, then place small items aside in safe location.
3. Unbolt machine from metal skids.
4. Carefully lift machine off metal skids and move it to prepared location, then lower machine into position.

Anchoring to Floor (G1079R)

Anchoring machinery to the floor prevents tipping or shifting and reduces vibration that may occur during operation, resulting in a machine that runs slightly quieter and feels more solid.

If the machine will be installed in a commercial or workplace setting, or if it is permanently connected (hardwired) to the power supply, local codes may require that it be anchored to the floor.

If not required by any local codes, fastening the machine to the floor is an optional step. If you choose not to do this with your machine, we recommend placing it on machine mounts, as these provide an easy method for leveling and they have vibration-absorbing pads.

Anchoring to Concrete Floors

Lag shield anchors with lag screws (see below) are a popular way to anchor machinery to a concrete floor, because the anchors sit flush with the floor surface, making it easy to unbolt and move the machine later, if needed. However, anytime local codes apply, you **MUST** follow the anchoring methodology specified by the code.

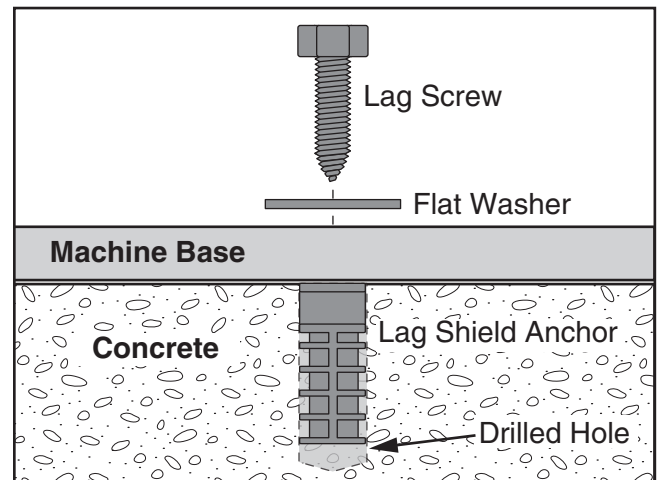

Figure 12. Popular method for anchoring machinery to a concrete floor.



Assembly

The machine must be fully assembled before it can be operated. Before beginning the assembly process, refer to **Needed for Setup** and gather all listed items. To ensure the assembly process goes smoothly, first clean any parts that are covered or coated in heavy-duty rust preventative (if applicable).

To assemble machine:

1. Attach (2) 4" dust ports to top cover with double-sided tape, as shown in **Figure 13**.

Note: The dust ports on the Model G1066Z are positioned front-to-back, rather than side-by-side as on the G1066R and G1079R. Attach the dust hoods to the Model G1066Z in the same manner as described here.

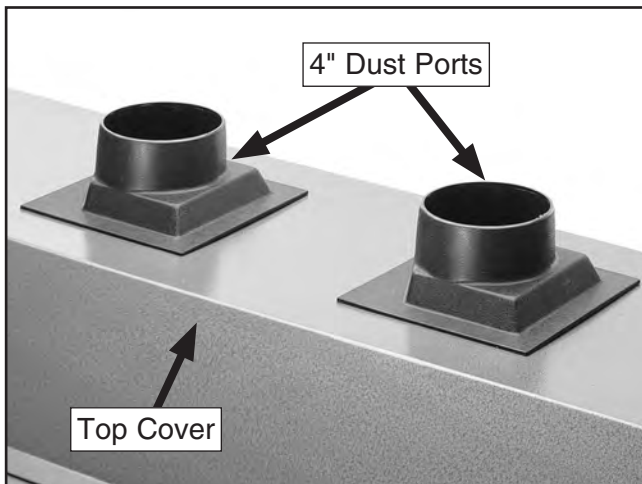

Figure 13. Dust ports attached to top cover (G1066R shown).

2. Secure dust ports to top cover with (8) #8 x 1/2" self-tapping screws and (8) 10mm flat washers.

⚠ CAUTION

DO NOT operate machine without an adequate dust-collection system. This machine creates substantial amounts of wood dust while in operation. Failure to use a dust-collection system can result in short- and long-term respiratory illness.

3. Attach crank handle (see **Figure 14**) to leadscrew shaft and secure with (2) pre-installed set screws. Crank handle may be attached to leadscrew on left, right, front or rear of machine, depending on operator preference.

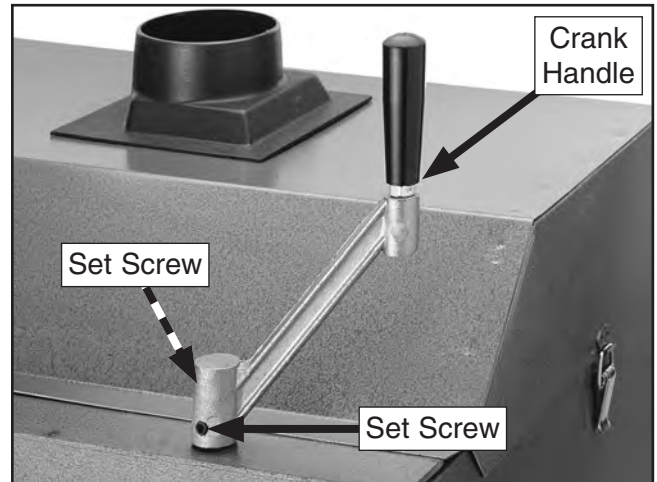

Figure 14. Crank handle attached to right front leadscrew shaft (G1066R shown).

4. **G1066Z Only:** Attach control panel pedestal to right side of machine with (2) 5/16"-18 x 1" hex bolts and (2) 5/16" flat washers, as shown in **Figure 15**.

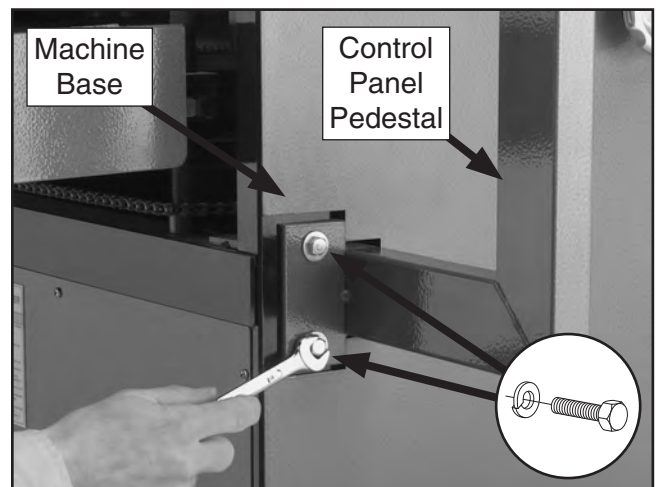

Figure 15. Attaching control panel to machine base.



- G1066Z Only:** Attach front panel to machine base with (8) #8 x $\frac{3}{8}$ " self-tapping screws, as shown in **Figure 16**.

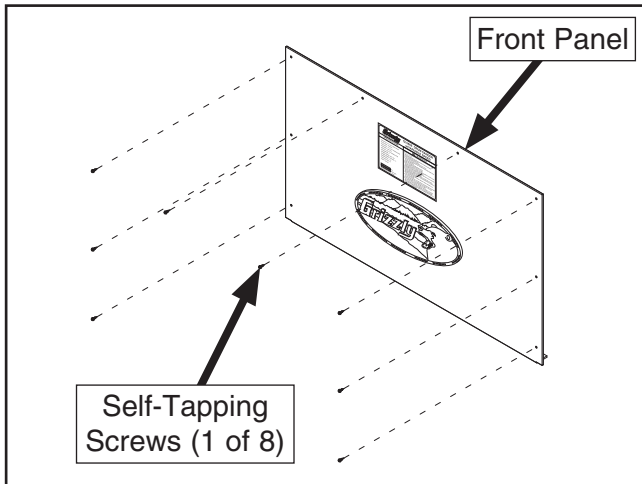

Figure 16. Diagram of front panel and screw locations.

Dust Collection

⚠ CAUTION

This machine creates a lot of wood chips/dust during operation. Breathing airborne dust on a regular basis can result in permanent respiratory illness. Reduce your risk by wearing a respirator and capturing the dust with a dust-collection system.

Minimum CFM at Dust Port: 400 CFM

Do not confuse this CFM recommendation with the rating of the dust collector. To determine the CFM at the dust port, you must consider these variables: (1) CFM rating of the dust collector, (2) hose type and length between the dust collector and the machine, (3) number of branches or wyes, and (4) amount of other open lines throughout the system. Explaining how to calculate these variables is beyond the scope of this manual. Consult an expert or purchase a good dust collection "how-to" book.

To connect dust-collection system to machine:

- Fit (2) 4" dust hoses over dust ports (see **Figure 17**), and secure in place with (2) hose clamps.

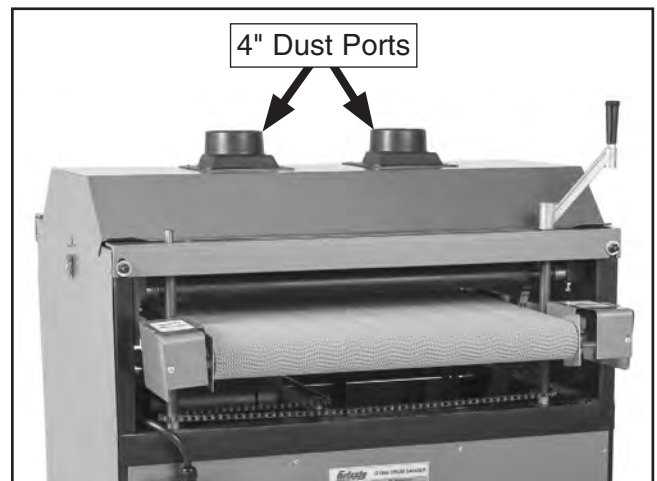

Figure 17. Location of 4" dust ports (G1066R shown).

- Tug hoses to make sure they do not come off. A tight fit is necessary for proper performance.



Test Run

Once assembly is complete, test run the machine to ensure it is properly connected to power and safety components are functioning correctly.

If you find an unusual problem during the test run, immediately stop the machine, disconnect it from power, and fix the problem **BEFORE** operating the machine again. The **Troubleshooting** table in the **SERVICE** section of this manual can help.

!WARNING

Serious injury or death can result from using this machine BEFORE understanding its controls and related safety information. DO NOT operate, or allow others to operate, machine until the information is understood.

!WARNING

DO NOT start machine until all preceding setup instructions have been performed. Operating an improperly set up machine may result in malfunction or unexpected results that can lead to serious injury, death, or machine/property damage.

G1066R/G1079R

For Model G1066R/G1079R, the Test Run verifies that the motors power up and run correctly prior to regular operation.

To test run machine:

1. Clear all setup tools away from machine.
2. Connect machine to power supply.
3. Turn machine **ON** to verify motor operation, and then turn machine **OFF**. A correctly operating machine will run smoothly with little or no vibration or rubbing noises.
 - If machine *runs* smoothly, congratulations, the Test Run is complete!
 - If machine *does not run* smoothly, immediately turn machine **OFF** and call Tech Support for help.

G1066Z

For Model G1066Z, the Test Run verifies the following:

- 1) The motors power up and run correctly.
- 2) The Emergency Stop button works correctly.

To test run the machine:

1. Clear all setup tools away from machine.
2. Push Emergency Stop button (see **Figure 18**).



Figure 18. Location of Emergency Stop button.

3. Connect machine to power supply.
4. Twist Emergency Stop button clockwise until it pops out (see **Figure 19**). This resets button so machine will start.

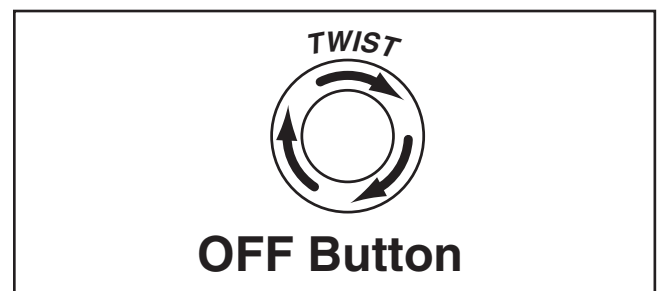

Figure 19. Resetting the OFF button.

5. Push Sanding Drum Motor **ON** button to turn motor **ON**. A correctly operating machine will run smoothly with little or no vibration or rubbing noises.
 - If sanding drums *run* smoothly, proceed to **Step 6**.
 - If sanding drums *do not run* smoothly, immediately turn machine **OFF** and call Tech Support for help.



6. Push Conveyor Motor ON button to turn motor **ON**. A correctly operating machine will run smoothly with little or no vibration or rubbing noises.
 - If conveyor belt *runs* smoothly, proceed to **Step 7**.
 - If conveyor belt *does not run* smoothly, immediately turn machine **OFF** and call Tech Support for help.
7. Push Emergency Stop button to turn machine **OFF**.
8. WITHOUT resetting Emergency Stop button, press Sanding Drum Motor ON button and Conveyor Motor ON button. Motors should not start.
 - If both motors *do not start*, the Emergency Stop safety feature is working correctly. Congratulations! The Test Run is complete.
 - If either motor *starts* (with Emergency Stop button pushed in), immediately disconnect power from machine. The Emergency Stop safety feature is not working correctly. This safety feature must work properly before proceeding with regular operations. Call Tech Support for help.

Recommended Adjustments

For your convenience, the adjustments listed below have been performed at the factory and no further setup is required to operate your machine. However, because of the many variables involved with shipping, we recommend that you at least verify the following adjustments to ensure the best possible results from your new machine.

Factory adjustments that should be verified:

- Conveyor Belt Tensioning & Tracking (**Page 43**).
- Drum Alignment (**Page 40**).
- Pressure Roller Height (**Page 42**).

Tightening Belts

The final step in the setup process must be done after approximately 16 hours of operation. During this first 16 hours, the belt(s) will stretch and seat into the pulley grooves. After this time, you must re-tension the belt(s) to avoid slippage and burn out. Refer to **Page 45** when you are ready to perform this important adjustment.

Note: *Pulleys and belt(s) can get hot. This is a normal condition. Allow them to cool before making adjustments.*

A small amount of black belt dust at the bottom of the belt housing is normal during the life of the machine and does not indicate a problem with the machine or belt.



Disabling & Locking Switch (G1079R)

The ON/OFF switch can be disabled and locked by inserting a padlock through the ON button, as shown. Locking the switch in this manner can prevent unauthorized operation of the machine, which is especially important if the machine is not stored inside an access-restricted building.

IMPORTANT: Locking the switch with a padlock only restricts its function. It is not a substitute for disconnecting power from the machine when adjusting or servicing.

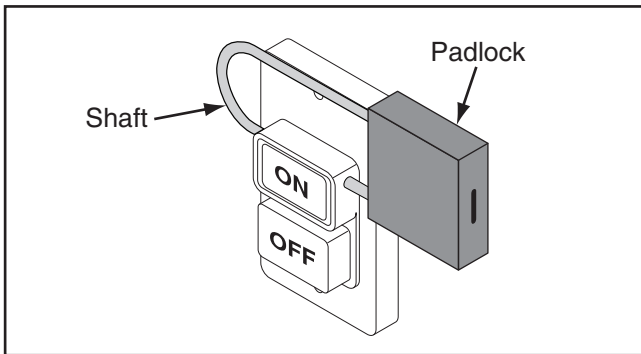

Figure 20. Switch disabled by a padlock.

⚠️ WARNING

Children or untrained people can be seriously injured by this machine. This risk increases with unsupervised operation. To help prevent unsupervised operation, disable and lock the switch before leaving machine unattended! Place key in a well-hidden or secure location.

NOTICE

The padlock shaft diameter is important to the disabling function of the switch. With any padlock used to lock the switch, test the switch after installation to ensure that it is properly disabled.

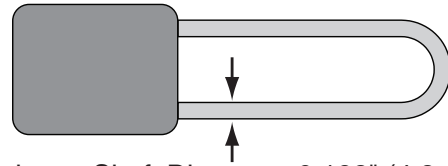

Minimum Shaft Diameter: 0.192" (4.8mm)
Maximum Shaft Diameter: 0.2" (5.0mm)

Figure 21. Minimum lock shaft requirements.



SECTION 4: OPERATIONS

Operation Overview

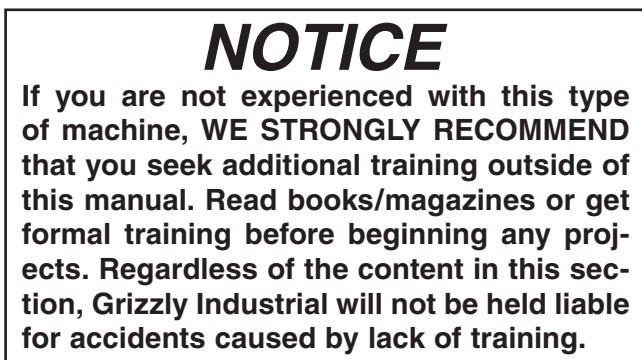
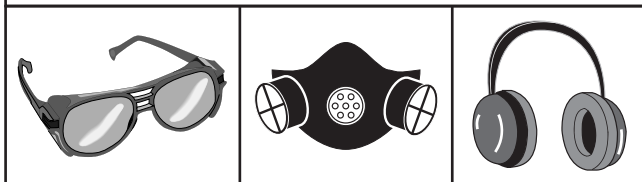
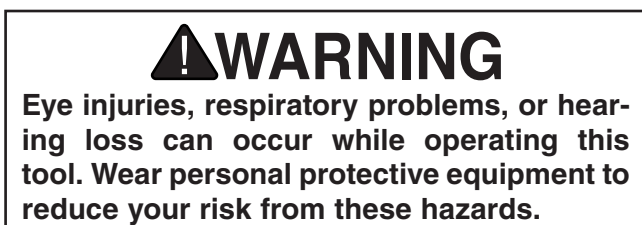

To complete a typical sanding operation, the operator does the following:

1. Examines workpiece to verify it is suitable for sanding and determines which sandpaper grit size to use.
2. Verifies workpiece has necessary outfeed clearance and support. If workpiece is overly long and difficult to handle, operator uses a roller support stand or an assistant to assist with feeding.
3. Adjusts table height to approximate workpiece thickness.

Note: During initial pass with a new workpiece, operator adjusts table height as necessary so workpiece only makes light contact with sanding belt and does not overload sander.

4. Puts on safety glasses, respirator, and any other required protective equipment.
5. Starts dust-collection system, and then drum sander. Waits for sanding drums and conveyor belt to reach full speed. If equipped, sets conveyor speed for the specific type and finish of workpiece.
6. Feeds workpiece into sander by placing front end on infeed side of conveyor table and supporting back end until workpiece engages with pressure rollers.
7. Receives workpiece from outfeed side of conveyor table.
8. Raises height of conveyor table a small amount (typically $\frac{1}{4}$ of a full rotation of crank handle), then repeats the feeding process of workpiece through sander.
9. Changes sandpaper to a finer grit, as needed.
10. Repeats **Steps 6–9** as needed, turns sander **OFF**, and disconnects it from power.



Stock Inspection and Requirements

Some workpieces are not safe to sand, or they may require further preparation before they can be safely sanded without increasing risk of injury to the operator or damaging the sanding belt or the sander.

Before sanding, inspect all workpieces for the following:

- **Material Type:** This machine is intended for sanding natural and man-made wood products, and laminate-covered wood products. This machine is NOT designed to sand glass, stone, tile, plastics, drywall, cementitious backer board, metal, etc.

Sanding metal objects can increase the risk of fire. Sanding improper materials increases the risk of respiratory harm to the operator and bystanders due to the especially fine dust inherently created by all types of sanding operations—even if a dust collector is used. Additionally, the life of the machine and sanding belts may be greatly reduced (or immediately damaged) from sanding improper materials.

- **Foreign Objects:** Tramp metal, nails, staples, dirt, rocks and other foreign objects are often embedded in wood. While sanding, these objects can become dislodged and tear the sanding belt. Always visually inspect your workpiece for these items. If they can't be removed, DO NOT sand the workpiece.
- **Wet or "Green" Stock:** Sanding wood with a moisture content over 20% causes unnecessary clogging and wear on the sanding belt, increases the risk of kickback, and yields poor results.
- **Excessive Warping:** Workpieces with excessive cupping, bowing, or twisting are dangerous to sand because they are unstable and often unpredictable when being sanded. DO NOT use workpieces with these characteristics!

- **Excessive glue or finish:** Sanding workpieces with excess glue or finish will load up the abrasive, reducing its usefulness and lifespan.
- **Minimum Stock Dimensions:** DO NOT sand boards less than 9" long, 2" wide, and 1/8" thick (G1066R/G1066Z) or 1/4" thick (G1079R) to prevent damage to the workpiece and to reduce the risk of your hands contacting the abrasive belt (see **Figure 22**).

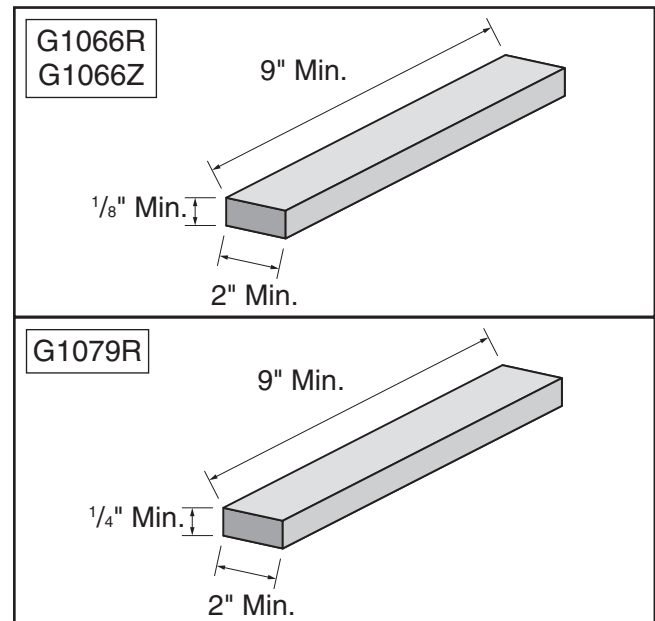

Figure 22. Minimum dimensions for sanding.

Choosing Sandpaper

There are many types of sandpaper rolls to choose from. We recommend Aluminum Oxide for general workshop environments. Below is a chart that groups abrasives into different classes, and shows which grits fall into each class.

Grit	Class	Usage
36	Extra Coarse	Rough sawn boards, thickness sanding, and glue removal.
60	Coarse	Thickness sanding and glue removal.
80–100	Medium	Removing planer marks and initial finish sanding.
120–180	Fine	Finish sanding.



The general rule of thumb is to sand a workpiece with progressively higher grit numbers, with no one grit increase of more than 50. Avoid skipping grits; the larger the grit increase, the harder it will be to remove the scratches from the previous grit.

The Model G1066R/G1066Z/G1079R allows you to place a different grit sandpaper on each drum. The front drum should have a coarser grit than the rear. Usually this translates into combinations of successive group types. A common selection for stock that is planed before being sanded is a 100/150 grit combination.

Ultimately, the type of wood you use and your stage of finish will determine the best grit types to install on your sander.

Overloading the motor or pushing the sander to failure weakens the electrical system. Repeatedly doing so is abuse to the machine that will cause motor, capacitor, or circuit breaker damage, which is not covered under warranty.

Sanding Tips

- Replace the sandpaper with a higher grit to achieve a finer finish.
- Raise the table with a maximum of $\frac{1}{4}$ turn of the height handle until the workpiece is the desired thickness.
- Reduce snipe when sanding more than one board of the same thickness by feeding them into the sander with the front end of the second board touching the back end of the first board.
- Feed boards into the sander at different points on the conveyor to maximize sandpaper life and prevent uneven conveyor belt wear.
- DO NOT sand boards less than 9" long, 2" wide, and $\frac{1}{8}$ " thick (G1066R/G1066Z) or $\frac{1}{4}$ " thick (G1079R) to prevent damage to the workpiece and the drum sander.
- Extend sandpaper life by regularly using a PRO-STICK® sanding pad (**Page 35**).

- When sanding workpieces with irregular surfaces, such as cabinet doors, take very light sanding passes to prevent gouges. When the drum moves from sanding a wide surface to sanding a narrow surface, the load on the motor will be reduced, and the drum will speed up, causing a gouge.
- DO NOT edge sand boards. This can cause boards to kickback, causing serious personal injury. Edge sanding boards also can cause damage to the conveyor belt and sandpaper.
- When sanding workpieces with a bow or crown, place the high point up (prevents the workpiece from rocking) and take very light passes.
- Feed the workpiece at an angle to maximize stock removal and sandpaper effectiveness, but feed the workpiece straight to reduce sandpaper grit scratches for the finish passes.

To clean sandpaper rolls:

1. Set table to thickness of cleaning pad.
2. Run pad through sander two or three times, as shown in **Figure 23**. DO NOT take too deep of a cut—the sandpaper should barely touch cleaning pad!



Figure 23. Example of using D3003 PRO-STIK® Cleaning Pad to clean sandpaper.



Sanding

!WARNING

DO NOT sand more than one board at a time. Minor variations in thickness can cause one board to be propelled by the rapidly spinning sanding drum and ejected from the machine. NEVER stand directly in front of the outfeed area of the machine. Failure to do so could result in severe personal injury.

To sand a workpiece:

1. Adjust table height (refer to **Setting Depth of Cut** on **This Page**.)
2. Make sure dust-collection hoses and collection system are secured and turned on before starting sander.
3. Turn machine **ON** and feed workpiece through sander. To reduce likelihood of injury, retrieve workpiece by standing to side of machine—not at outfeed end.
4. Run wide stock through two or three times without adjusting table height. Turn stock 180° between passes to ensure an evenly sanded surface.

Tip: For best sanding results, always sand with the grain during finish passes.

5. Turn machine **OFF**.

NOTICE

Overloading the motor or pushing the sander to failure weakens the electrical system. Repeatedly doing so is abuse to the machine that will cause motor, capacitor, or circuit breaker damage, which is not covered under warranty.

Setting Depth of Cut

The optimum depth of cut will vary based on the type of wood, feed rate, and sandpaper grit. Under most sanding conditions, the depth should not exceed $\frac{1}{64}$ " (approx. $\frac{3}{4}$ turn of the handwheel). Each full turn of the table height handwheel raises the conveyor table approximately 0.020". Attempts to remove too much material can cause jamming, wood burning, rapid paper wear or tearing, poor finish, and belt slippage.

To set the depth of cut:

1. Rotate table height crank handle (see **Figure 24**) until table is too low, then raise table, allowing a gap between workpiece and sanding drum.

Note: When adjusting the table to sand a thicker workpiece, lower and then raise the table to remove backlash from the adjustment mechanism.

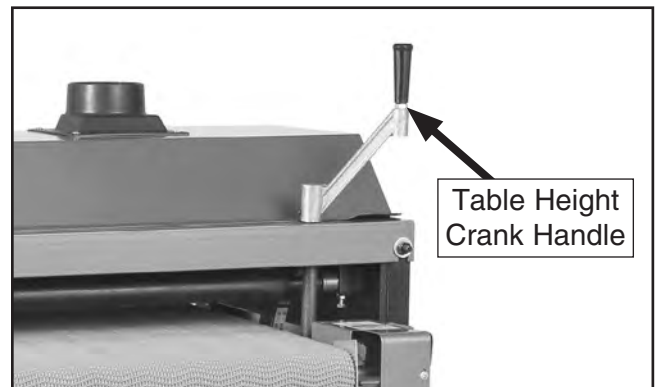

Figure 24. Location of table height crank handle (G1066R shown).

2. Start conveyor and sanding drums and feed workpiece into sander. **SLOWLY** raise conveyor table until workpiece makes light contact with sanding drums. This is the correct height to begin sanding the workpiece.



Setting Conveyor Speed (G1066Z)

The conveyor speed control allows you to set the conveyor speed from 0–10 (0–20 FPM). The correct speed to use depends on the type of stock you are using (hardwood vs. softwood) and the stage of finish you are at with that workpiece.

As a general rule, a slower speed will sand the surface smoother, but runs the risk of burning the wood; a faster speed will remove material faster, but runs the risk of overloading the motor. Use trial-and-error to determine the best settings for your specific applications.

To set conveyor speed:

1. Set conveyor speed control to "0," and then turn conveyor motor **ON**.
2. Slowly turn conveyor speed control (see **Figure 25**) clockwise to increase conveyor speed.

— If conveyor speed is too high, turn control counterclockwise to decrease conveyor speed.

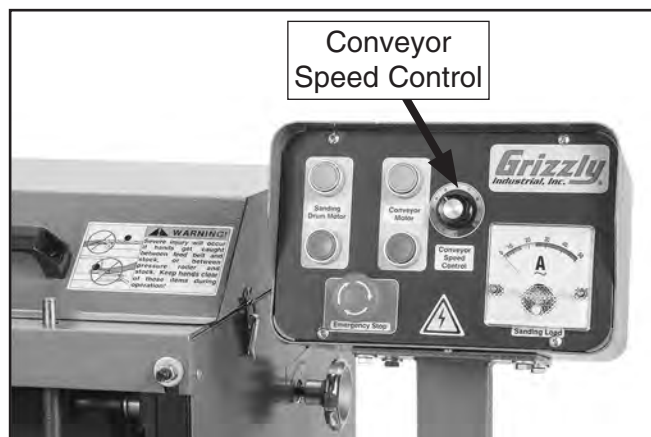

Figure 25. Location of conveyor speed control (G1066Z).

Monitoring Sanding Load (G1066Z)

The load meter (see **Figure 26**) displays the amperage draw of the sanding drum motor. The needle moves to the right when you increase the load on the sanding drums and moves to the left when you decrease the load. Use this meter to avoid overloading your machine with too heavy of a cut.

IMPORTANT: NEVER exceed 25 amps—this is the maximum that your machine can safely handle!

Since various types of stock will react differently with various loads, use trial-and-error to determine the best settings for your applications. As a general rule, always start with a small load and work your way up. We recommend that you do not push your machine to its maximum load; instead, make multiple passes or install a coarser grit paper.

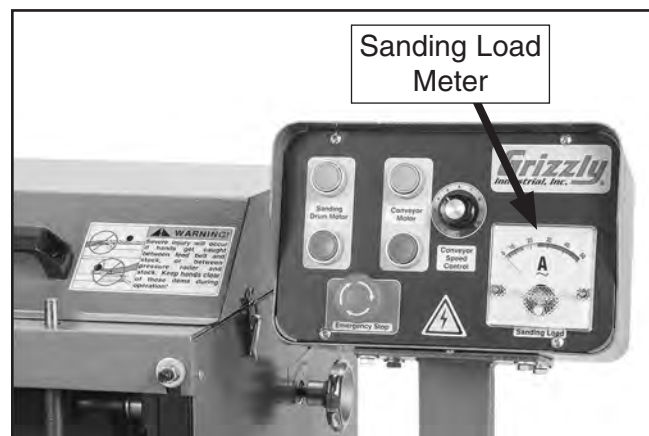

Figure 26. Location of load meter (G1066Z).

NOTICE

Overloading the motor or pushing the sander to failure weakens the electrical system. Repeatedly doing so is abuse to the machine that will cause motor, capacitor, or circuit breaker damage, which is not covered under warranty.



Installing/Replacing Sandpaper (G1066R/G1079R)

The Model G1066R/G1079R is designed for 6" wide sandpaper rolls. The sandpaper roll attaches to the sanding drums with a spring clip on one end and strapping tape on the other end of the drum. The outfeed sanding drum is wrapped in felt to slightly increase the drum diameter and to provide a smooth sanded surface. The felt is 1" from the edge of the drum to allow room for the tape to adhere.

Item(s) Needed	Qty
Hammer or Mallet.....	1
Strapping Tape 3/4".....	1

To change the sandpaper:

1. DISCONNECT MACHINE FROM POWER!
2. Remove/open top cover.
3. Remove tape from right side of first sanding drum, and then remove spring clip that attaches sandpaper to left side of drum (see Figure 27).

⚠ CAUTION

Be careful that the tension wheel does not pinch your fingers when the pressure is released and it snaps back to a relaxed position.

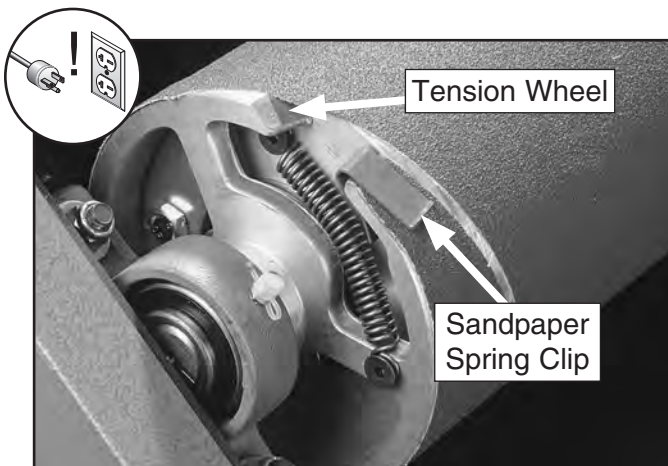

Figure 27. Sanding drum components.

Model G1066R/Z/G1079R (Mfd. Since 02/11)



4. Unwind old sandpaper and use it as a pattern (or use pattern in Figure 28) to cut a piece of 6" wide sandpaper of desired grit. It is necessary to cut away a triangular portion of sandpaper at each end.

Tip: Note direction sandpaper was wrapped around drum.

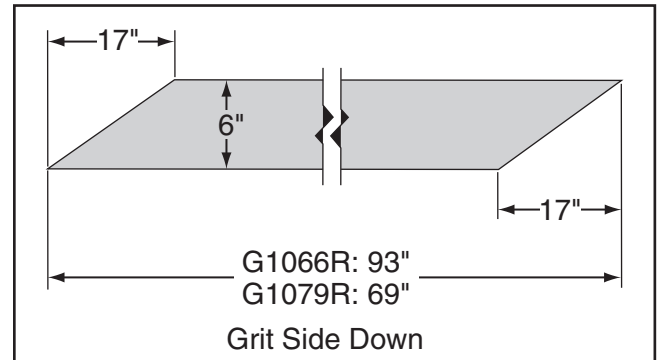

Figure 28. Sandpaper pattern (G1066R/G1079R).

5. Starting at left side of drum, fold corner of sandpaper into spring clip, then install spring clip onto tensioner.

Note: You may need to tap spring clip with a hammer or mallet to ensure it is seated; however, you do not have to drive clip completely on, just make sure it is secure. Too much force will break the clip! Also, do not fold paper over tensioner and then install spring clip—the paper may tear as a result.

6. Pull sandpaper until tension wheel spring has bottomed-out in its travel.

NOTICE

The following step is possible to accomplish alone, but it is much easier with help from another person.

7. While one person rolls the drum, the other tightly spirals sandpaper onto drum, ensuring that there are no bubbles or overlapping edges.

Tip: Try to leave a uniform 3/16" gap between spirals as you wind sandpaper around drum. This will allow sandpaper to move and stretch slightly and will decrease likelihood of tearing and overlapping.

8. Hold loose end of sandpaper against right side of drum and wrap with strapping tape to secure. Double-check drum to make sure there are no bubbles or overlapping edges and gapping is correct.
9. Repeat **Steps 1–8** for second drum.
10. Close/re-install top cover. Make sure dust-collection hoses are secure.

Important Tips For Changing Sandpaper:

- Replace sandpaper on each drum individually. Once paper is removed from both drums, they can be slippery and hard to rotate.
- Always fold sandpaper into spring clip and then insert it.
- The spring clip does not have to be driven completely on.
- Changing sandpaper is easier with help from another person.

Installing/Replacing Sandpaper (G1066Z)

The Model G1066Z is designed for 3" wide hook-and-loop sandpaper rolls.

Item(s) Needed	Qty
Strapping Tape 3/4".....	As Needed

To change the sandpaper:

1. DISCONNECT MACHINE FROM POWER!
2. Remove/open top cover.

3. If needed, remove tape from first sanding drum and unwind old sandpaper. Use it as a pattern (or use pattern in **Figure 29**) to cut a piece of 3" wide sandpaper of desired grit. It is necessary to cut away a triangular portion of sandpaper at each end.

Tip: Note direction sandpaper was wrapped around drum.

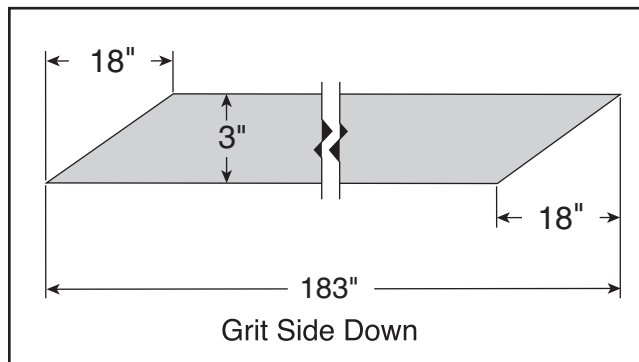

Figure 29. Sandpaper pattern (G1066Z).

4. Wrap drum with new sandpaper. Try to keep gaps to a minimum, and make sure to wrap sandpaper tight with no bubbles or overlapping edges.
5. Tape both ends with 3/4" strapping tape, making at least two complete passes so second layer is directly on top of first (see **Figure 30**).

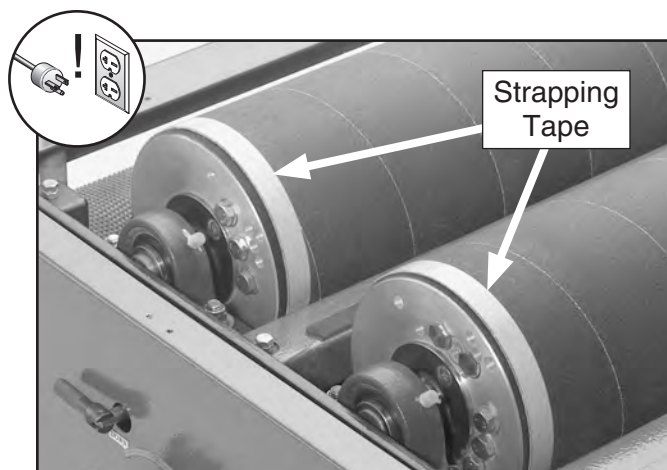

Figure 30. Strapping tape securing sandpaper roll to drums.

6. Repeat **Steps 3–5** with second drum.
7. Close/re-install top cover. Make sure dust-collection hoses are secure.



SECTION 5: ACCESSORIES

!WARNING

Installing unapproved accessories may cause machine to malfunction, resulting in serious personal injury or machine damage. To reduce this risk, only install accessories recommended for this machine by Grizzly.

NOTICE

Refer to our website or latest catalog for additional recommended accessories.

Aluminum Oxide Sanding Rolls, 6" x 50'

H4776—36 Grit: Use for rough sawn boards, thickness sanding, and glue removal.

G2787—60 Grit: Use for thickness sanding and glue removal.

H4777—80 Grit: Use for removing planer marks and initial finish sanding.

G2788—100 Grit: Use for removing planer marks and initial finish sanding.

H4778—120 Grit: Use for finish sanding.

G2789—150 Grit: Use for finish sanding.

Aluminum Oxide Sanding Rolls 3" x 22'

T23880—60-Grit: Use for thickness sanding and glue removal.

T23881—80-Grit: Use for removing planer marks and initial finish sanding.

T23882—100-Grit: Use for removing planer marks and initial finish sanding.

T23883—120-Grit: Use for finish sanding.

T23884—150-Grit: Use for finish sanding.

T23885—180-Grit: Use for finish sanding.

T23886—220-Grit: Use for finish sanding.

Model D3003—PRO-STIK® Cleaning Pad

Extend the life of your sandpaper! Just feed this crepe-rubber cleaning pad through your drum sander to remove dust build-up from the sandpaper without damage. Measures 15" x 20" x 1 1/8".

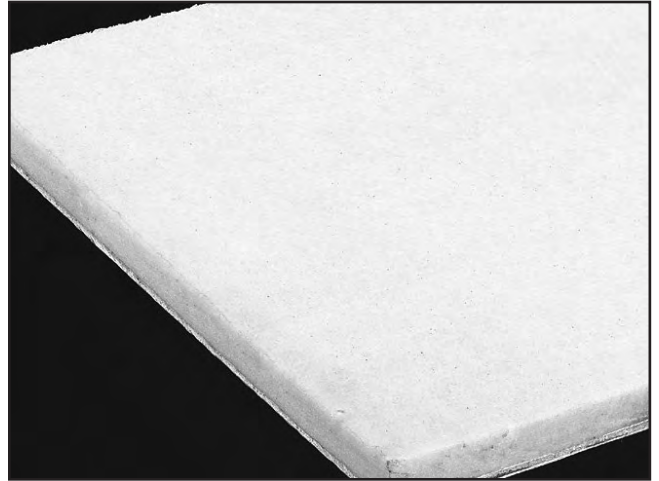

Figure 31. D3003 PRO-STIK® Cleaning Pad.

T28172—14" x 39" Heavy-Duty Roller Table

T28369—14" x 78" Heavy-Duty Roller Table

T28370—14" x 118" Heavy-Duty Roller Table

Increase material handling and processing efficiency with one or more of these Heavy-Duty Roller Tables. Ideal for easily positioning of material into sander. Simply place a roller table on one or both sides of your sander and production time is automatically improved!



Figure 32. Heavy-duty roller tables.

order online at www.grizzly.com or call 1-800-523-4777



- D4206—Clear Flexible Hose 4" x 10'
- D4256—45° Elbow 4"
- D4216—Black Flexible Hose 4" x 10'
- W1034—Heavy-Duty Clear Flex Hose 4" x 10'
- D2107—Hose Hanger 4¼"
- W1015—Y-Fitting 4" x 4" x 4"
- W1017—90° Elbow 4"
- W1019—Hose Coupler (Splice) 4"
- W1317—Wire Hose Clamp 4"
- W1007—Plastic Blast Gate 4"
- W1053—Anti-Static Grounding Kit

We've hand picked a selection of commonly used dust collection components for machines with 4" dust ports.



Figure 33. Dust collection accessories.

- H2499—Small Half-Mask Respirator
- H3631—Medium Half-Mask Respirator
- H3632—Large Half-Mask Respirator
- H3635—Cartridge Filter Pair P100

If you work around dust everyday, a half-mask respirator can be a lifesaver. Also compatible with safety glasses!



Figure 34. Half-mask respirator with disposable cartridge filters.

Basic Eye Protection

- T20501—Face Shield Crown Protector 4"
- T20502—Face Shield Crown Protector 7"
- T20503—Face Shield Window
- T20451—"Kirova" Clear Safety Glasses
- T20452—"Kirova" Anti-Reflective S. Glasses
- T20456—DAKURA Safety Glasses



Figure 35. Assortment of basic eye protection.



SECTION 6: MAINTENANCE

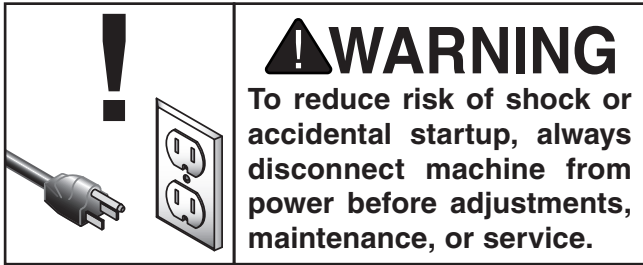

Schedule

For optimum performance from this machine, this maintenance schedule must be strictly followed.

Ongoing

To maintain a low risk of injury and proper machine operation, if you ever observe any of the items below, shut down the machine immediately and fix the problem before continuing operations:

- Worn or damaged sandpaper rolls.
- Loose mounting bolts.
- Any other unsafe condition.

Weekly Maintenance

- Clean/vacuum dust buildup from underneath top cover.
- Clean/vacuum dust buildup from inside cabinet and off motor.
- Lubricate pillow bearings.

Monthly Check

- V-belt tension, damage, or wear.

Cleaning

Cleaning the Model G1066R/G1066Z/G1079R is relatively easy. Vacuum excess wood chips and sawdust, and wipe off the remaining dust with a dry cloth. If any resin has built up, use a resin dissolving cleaner to remove it.

Lubrication

Pillow Bearings

Lube Type..... T26419 or NLGI#2 Equivalent
Lube Amount..... 1–2 Pumps
Lube Frequency20 Hours

Item(s) Needed:..... **Qty**
Grease Gun..... 1
Shop Rags..... As Needed

The pillow bearings require a small amount of grease every 20 hours of operation to ensure smooth sanding drum rotation. The four pillow bearings are lubricated by grease fittings (see **Figure 36**). To lubricate pillow bearings, remove grease fitting cap, use a grease gun to pump a small amount of grease into fittings, then re-attach cap.

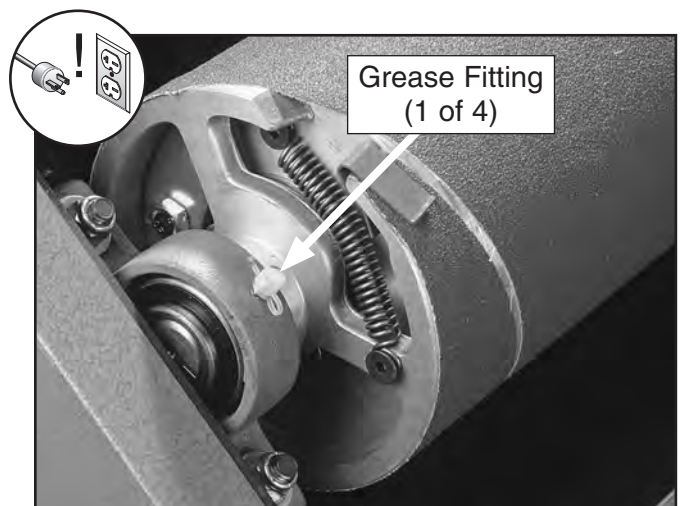

Figure 36. Location of grease fittings.



SECTION 7: SERVICE

Review the troubleshooting procedures in this section if a problem develops with your machine. If you need replacement parts or additional help with a procedure, call our Technical Support. **Note:** *Please gather the serial number and manufacture date of your machine before calling.*

Troubleshooting

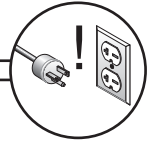

Motor & Electrical

Symptom	Possible Cause	Possible Solution
Machine does not start or a breaker trips.	<ol style="list-style-type: none"> Emergency Stop button depressed/at fault (G1066Z). Incorrect power supply voltage or circuit size. Power supply circuit breaker tripped/fuse blown. Machine circuit breaker tripped (G1079R). Wiring open/has high resistance. ON/OFF switch at fault Start capacitor at fault. Thermal overload relay has tripped. Contactors not energized/has poor contacts. Centrifugal switch at fault. Motor at fault. 	<ol style="list-style-type: none"> Rotate Emergency Stop button to reset. Replace if at fault (G1066Z). Ensure correct power supply voltage and circuit size. Ensure circuit is sized correctly and free of shorts. Reset circuit breaker or replace fuse. Reset circuit breaker on machine (G1079R). Check/fix broken, disconnected, or corroded wires. Test/replace. Test/replace. Allow to cool, then reset; replace. Test all legs for power/replace if at fault. Adjust centrifugal switch/contact points; replace if necessary. Test/repair/replace.
Machine stalls or is underpowered.	<ol style="list-style-type: none"> Workpiece material not suitable. Feed rate too fast (G1066Z). Excessive depth of cut. Sandpaper roll loaded up. Sandpaper roll worn or damaged. Machine undersized for task. Belt(s) slipping or pulleys misaligned. Motor overheated. Motor bearings at fault. Run capacitor at fault. Centrifugal switch at fault. Motor at fault. 	<ol style="list-style-type: none"> Ensure workpiece is suitable for sanding (Page 29). Reduce feed rate (G1066Z) (Page 32). Reduce depth of cut (Page 31). Clean sandpaper roll (Page 30). Replace sandpaper roll (Pages 33–34). Reduce feed rate/workpiece pressure. Tension/replace belt(s) (Page 45); ensure pulleys are aligned (Page 46). Clean motor, let cool, and reduce workload. Test/repair/replace. Test/replace. Test/replace. Test for good contacts/correct wiring.
Machine has vibration or noisy operation.	<ol style="list-style-type: none"> Sandpaper roll loose. Machine not stable on floor. Belt(s) loose or worn. Motor or component loose. Pulley(s) loose or misaligned. Motor fan rubbing on fan cover. Worn drum bearings. Centrifugal switch at fault. Motor bearings at fault. 	<ol style="list-style-type: none"> Re-install sandpaper roll (Pages 33–34). Relocate/shim machine; tighten mounting bolts. Tension/replace belt(s) (Page 45). Tighten mounting bolts; relocate/shim machine. Secure pulley on shaft or realign (Page 46). Fix/replace fan cover; replace loose/damaged fan. Test/repair/replace. Adjust centrifugal switch/contact points; replace if necessary. Test/repair/replace.



Operation

Symptom	Possible Cause	Possible Solution
Machine slows when sanding; makes squealing noise on start-up.	1. Belt(s) loose or worn.	1. Tension/replace belt(s) (Page 45).
Grinding, screeching, or rubbing noise from sanding drums.	1. Drum scraping on dust scoop. 2. Drum bearings need grease. 3. Drum bearings worn.	1. Adjust dust scoop so it does not contact drum (Page 44). 2. Grease drum bearings (Page 29). 3. Replace drum bearings (Page 47).
Machine lacks power; drums stop turning under load.	1. Too much pressure on sanding drum. 2. Belt(s) loose or worn.	1. Lower conveyor table (Page 31). 2. Tension/replace belts (Page 45).
Conveyor belt slips under load.	1. Conveyor belt loose or worn. 2. Workpiece too heavy.	1. Tension/replace conveyor belt (Page 43). 2. Use lighter workpiece.
Workpiece pulls to one side during sanding operations.	1. Sanding drum(s) not perpendicular to feed direction. 2. Sanding drum(s) not parallel with table.	1. Adjust sanding drum(s) perpendicular to feed direction (Page 40). 2. Adjust sanding drum(s) parallel to table (Page 41).
Workpiece kicks out of sander.	1. Not enough pressure from pressure rollers. 2. Sanding drum(s) not properly aligned.	1. Lower pressure rollers (Page 42). 2. Adjust sanding drum(s) alignment (Page 40).
Excessive snipe.	1. Lack of outfeed support. 2. Too much pressure from pressure rollers. 3. Too much pressure from rear pressure roller.	1. Set up outfeed table or have someone catch workpiece as it comes out. 2. Raise pressure rollers (Page 42). 3. Raise rear pressure roller (Page 42).
Sanding grains easily rub off roll.	1. Sandpaper roll has been stored in an incorrect environment. 2. Sandpaper roll has been smashed or folded.	1. Replace damaged sandpaper roll (Pages 33–34). Store sanding belt in a cool, dry area. 2. Replace damaged sandpaper roll (Pages 33–34). Do not bend or fold sanding belt.
Sandpaper comes off drum or is loose.	1. Sandpaper roll not properly wrapped around drum. 2. Sandpaper roll not correct size. 3. Torn or damaged sandpaper. 4. Sandpaper not tightened or fastened correctly. 5. Sanding drum not parallel with table.	1. Re-install sandpaper roll (Pages 33–34). 2. Cut sandpaper roll to correct dimensions (Pages 33–34). 3. Replace sandpaper roll (Pages 33–34). 4. Re-install sandpaper roll (Pages 33–34). 5. Adjust sanding drum parallel to table (Page 40).
Glazed sanding surface.	1. Workpiece has excessive moisture. 2. Workpiece has high amount of residue. 3. Sandpaper roll loaded up. 4. Sandpaper roll worn or damaged.	1. Only sand dry stock with moisture content below 20%. 2. Use different stock, or accept characteristics of stock and plan to clean/replace sanding belt frequently. 3. Clean sandpaper roll (Page 30). 4. Replace sandpaper roll (Pages 33–34).
Burn marks on workpiece.	1. Using too fine of sanding grit for depth of cut. 2. Sandpaper roll loaded up 3. Feed rate too slow (G1066Z). 4. Sandpaper roll not properly wrapped around drum. 5. Sandpaper roll worn or damaged.	1. Use coarser grit sandpaper (Page 29) or decrease depth of cut (Page 31). 2. Clean sandpaper roll (Page 30). 3. Increase feed rate (G1066Z) (Page 32). 4. Re-install sandpaper roll (Pages 33–34). 5. Replace sandpaper roll (Pages 33–34).



Aligning Drums

For the Model G1066R/G1066Z/G1079R Drum Sander to function properly, the sanding drums must be aligned in two directions: (1) perpendicular to feed direction (see **Figure 37**) and (2) parallel to the conveyor belt (see **Figure 38**).

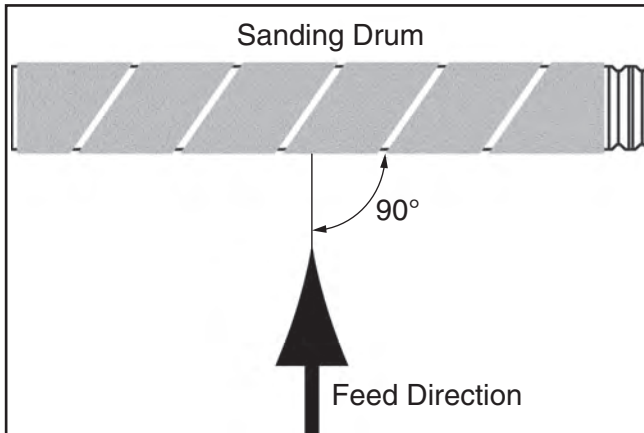

Figure 37. Feed direction perpendicular to sanding drum (viewed from top of machine).

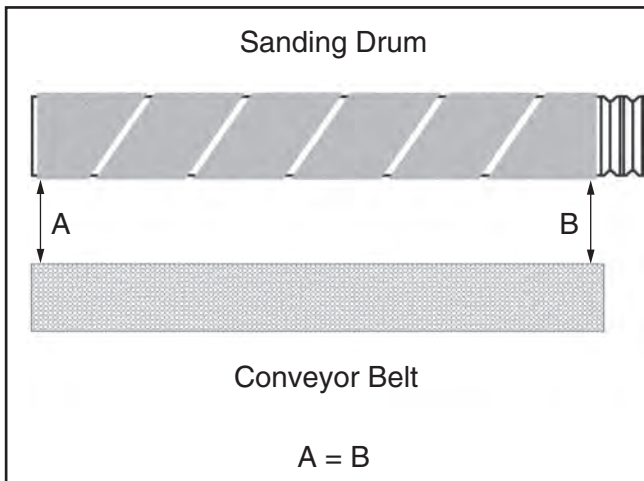

Figure 38. Sanding drum parallel to conveyor belt (viewed from front of machine).

⚠ CAUTION

Improper drum alignment could cause an uncontrolled exit of material from the machine—which could result in damage to property, premature wear and failure of sandpaper, or personal injury.

Adjusting Sanding Drums Perpendicular to Feed Direction

Item(s) Needed	Qty
Tape Measure.....	1
Open-End or Socket Wrench $\frac{9}{16}$ "	1

1. DISCONNECT MACHINE FROM POWER!
2. Measure distances between outside of infeed (front) sanding drum and inside of front brace on both ends of the drum.
 - If distances *are* within $\frac{1}{8}$ " of one another, no adjustment is necessary.
 - If distances *are not* within $\frac{1}{8}$ " of one another, infeed sanding drum needs to be aligned. Proceed to **Step 3**.
3. Repeat **Step 2** on outfeed (rear) sanding drum.

— If distances *are* within $\frac{1}{8}$ " of one another, no adjustment is necessary.

— If distances *are not* within $\frac{1}{8}$ " of one another, outfeed sanding drum needs to be aligned. Proceed to **Step 4**.

Note: If sanding drums are not perpendicular to feed direction, sandpaper will creep toward one end of drum during operation.

4. Loosen lock nuts on bearing blocks (see **Figure 39**) and adjust sanding drum forward or backward as necessary until distances between outside of drum and inside of front brace on both ends of drum are within $\frac{1}{8}$ " of one another.

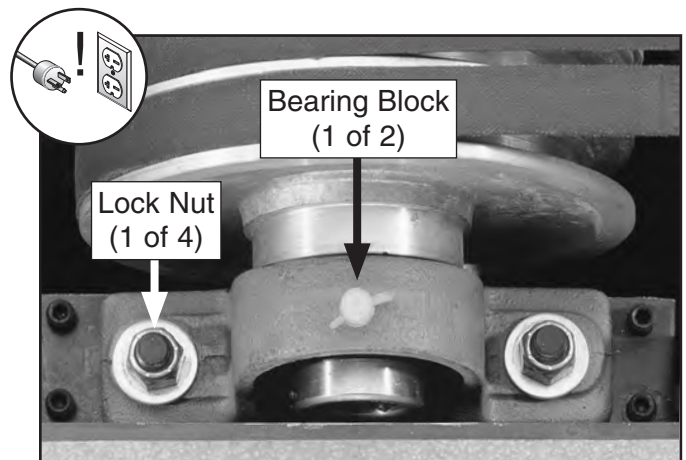

Figure 39. Location of bearing blocks.

Model G1066R/Z/G1079R (Mfd. Since 02/11)



- Tighten lock nuts and recheck alignment.

Note: *DO NOT over tighten lock nuts. Bearing blocks will break if over tightened.*

Adjusting Sanding Drums Parallel to Feed Belt

Item(s) Needed	Qty
2x4 Gauge Block (2" x 4" x 24")	1
Marking Tape or Felt Pen	1
Open-End or Socket Wrench $\frac{9}{16}$ "	1

- DISCONNECT MACHINE FROM POWER!
- Starting with infeed (front) sanding drum, lower table so gauge block slides easily under pressure bars. Slide block over to right side of table, with front edge lined up to front of table.

Note: *Make note of gauge block position to make sure same part of the gauge block is used to set drum heights.*
- Raise table up so gauge block just touches infeed pressure roller, and then raise table one full turn of crank handle.
- Adjust height of right side of front sanding drum so it just touches gauge block and is able to rotate back and forth with moderate resistance.
- Mark location of crank handle with a felt pen or piece of tape. In same manner, mark height of table in relation to the body of sander. Both these marks indicate exact table position (referred to as *Reference Height #1*).

Note: *Having Reference Height #1 marked is crucial to all subsequent steps.*

- Lower table two full turns. Remove gauge block and re-insert it on left side of table. Take care to line it up with front of table just as it was done on previous side.
- Raise table two full turns to bring it back up to *Reference Height #1*.
- Set height of front sanding drum to gauge block (refer to **Adjusting Drum Height on This Page** for instructions).

- Rotate front sanding drum back and forth. It should feel and sound as it did in Step 4. If not, adjust drum height again. Continue this process, going back and forth, until both sides of drum feel and sound the same.
- Lower table ($\frac{1}{8}$) turn from *Reference Height #1* and mark location of crank handle and table in relation to the body of sander. Both these marks indicate exact table position (referred to as *Reference Height #2*).

Note: *Model G1066Z has micro-adjustment controls on sides of machine for rear sanding drum adjustments. Other than this difference, the procedure for setting rear drum height is the same.*

- Lower table two full turns.
- Using *Reference Height #2*, repeat **Steps 7–9** on rear sanding drum until both sides of drum feel and sound the same.

Note: *Outfeed drum should always be slightly lower than infeed drum, the actual difference will vary depending on wood type, feed rate, sandpaper grits, etc. Once familiar with the adjustment process, experiment to determine the best settings for your specific application.*

Adjusting Drum Height

Item(s) Needed	Qty
2x4 Gauge Block (2" x 4" x 24")	1
Open-End or Socket Wrench $\frac{9}{16}$ "	1
Hex Wrench 3mm	1

- Loosen lock nuts (see **Figure 40**) on bearing block on side of drum requiring adjustment.

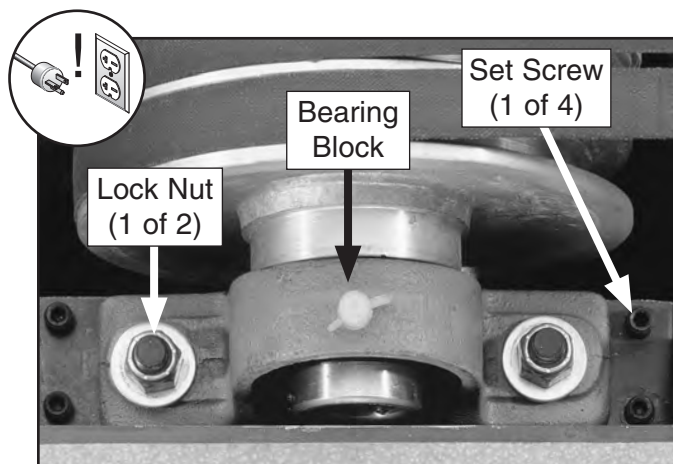

Figure 40. Bearing block components.



2. Raise or lower bearing block by rotating set screws (see **Figure 40**). Turn very gradually— $\frac{1}{8}$ turn or less.
3. Tighten lock nuts and re-check alignment using gauge block.

Note: Tightening lock nuts pulls sanding drum slightly downward. Re-adjust set screws as necessary to compensate for this movement. DO NOT over tighten lock nuts. Bearing blocks will break if over tightened. Also, DO NOT change table height until the lock nuts are tight.

4. Repeat **Steps 1–3** on other side of drum.

Note: Model G1066Z has micro-adjustment controls on sides of machine for rear sanding drum adjustments (see **Figure 41**).

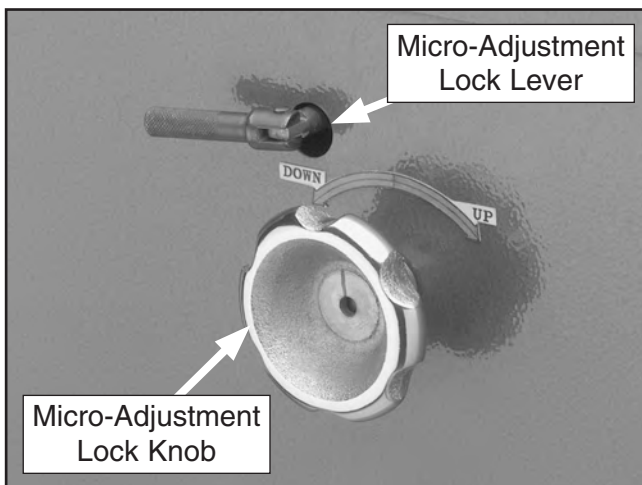

Figure 41. Model G1066Z rear drum micro-adjustment controls.

Adjusting Pressure Rollers

Proper pressure on the workpiece helps avoid kickback and keeps the workpiece from slipping. However, as pressure increases on the workpiece, snipe also increases (snipe is normal with all brands of drum sanders).

If snipe becomes a problem, you can minimize it by reducing pressure (raising pressure roller height). However, you can only minimize it so much before the workpiece will slip or kick out, causing a hazard to the operator. If this happens, you have raised the pressure rollers too high for them to function as intended—the pressure rollers MUST then be lowered to prevent injury.

Item(s) Needed	Qty
Open-End or Socket Wrench 10mm	1

To adjust pressure roller tension:

1. DISCONNECT MACHINE FROM POWER!
2. Remove top cover (disconnect dust-collection hoses if attached).
3. Loosen jam nuts on hex bolts (see **Figure 42**). Tighten hex bolts to increase pressure roller spring tension; loosen hex bolts to decrease pressure roller spring tension.

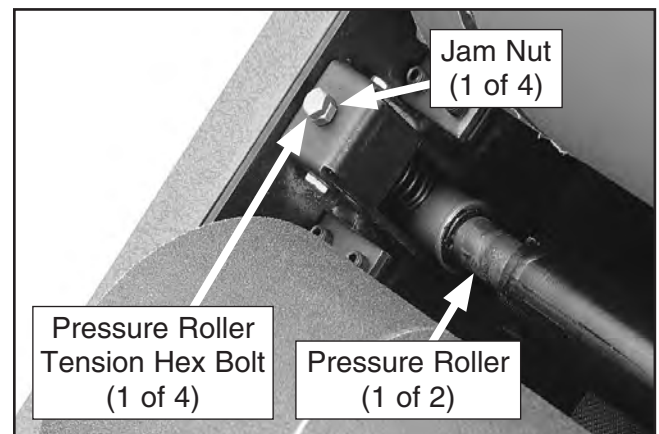

Figure 42. Location of pressure roller tensioners.



Note: Increasing pressure roller tension will increase workpiece pressure on the conveyor belt. Increasing this pressure could increase the likelihood of jams and make the sanding process less forgiving of irregularities in the workpiece. Experiment to determine optimal tension for your workpieces.

4. Replace top cover and reconnect dust-collection hoses.

To provide increased operator control, the Model G1066Z features height adjustment controls for the feed roller. These controls are located on the underside of the roller pressure spring controls and consist of a hex bolt and jam nut setup, exactly like the roller pressure spring tension controls.

Item(s) Needed	Qty
2x4 Gauge Block (2" x 4" x 24")	1
Phillips Screwdriver #2	1

To adjust pressure roller height on Model G1066Z:

1. Make sure drum alignment is set properly (refer to **Drum Alignment** on **Page 40** for instructions).
2. DISCONNECT MACHINE FROM POWER!
3. Remove roller bracket guards.
4. With gauge block in place on one side of table, raise table up to *Reference Height #1* (refer to **Page 41**).
5. Lower table one full turn.
6. On same side as gauge block, loosen jam nuts on roller height hex bolts.
7. Adjust all (3) pressure rollers by tightening or loosening hex bolts. The pressure rollers should just touch surface of gauge block, allowing enough room to rotate.
8. Tighten jam nuts on hex bolts to secure height position.

9. Repeat **Steps 4–9** on other side of table to make sure all pressure rollers are even and parallel to table.

Note: These adjustments should be used as a starting point. Once you are familiar with the adjustment process, you should experiment to determine the best settings for your specific application.

10. Re-install roller bracket guards.

Adjusting Conveyor Belt Tension

The conveyor belt tension and tracking adjustments are controlled by the adjustment bolts located at each end of the front and rear conveyor rollers. If the conveyor belt is too loose or tracks off to one side, it must be adjusted.

 WARNING

Always make conveyor belt adjustments at infeed end to avoid re-adjusting conveyor drive chain. Conveyor belt tracking adjustments must be made while the conveyor belt is running. Use extreme care to ensure that clothing, hair or jewelry is kept safely away from moving parts.

Item(s) Needed	Qty
Open-End Wrench 19mm.....	1
Phillips Screwdriver #2	1

To adjust conveyor belt tension and tracking:

1. Turn machine **ON** and watch conveyor belt tension and tracking. Be patient, belt tracks slowly.
2. DISCONNECT MACHINE FROM POWER!
3. Remove roller bracket guards.



4. Make conveyor belt tension and tracking adjustments:
 - If belt slips on rollers, rotate both roller adjustment bolts (see **Figure 43**) counterclockwise to increase belt tension.

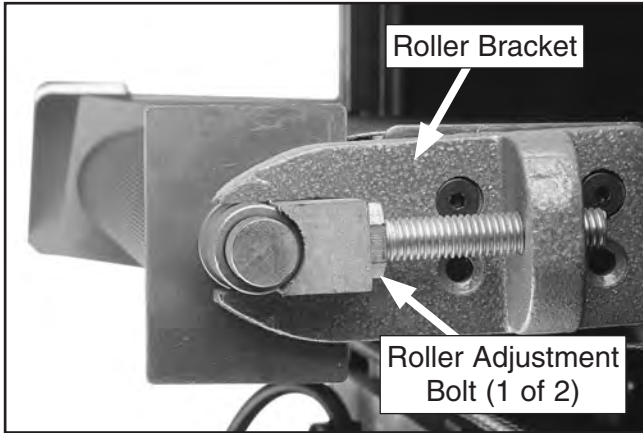

Figure 43. Location of conveyor roller adjustment bolts.

- If belt tracks toward right, rotate right-side roller adjustment bolt counterclockwise to move belt left.
 - If belt tracks toward left, rotate right-side roller adjustment bolt clockwise to move belt right.
5. After adjustments are made, run machine for approximately 15 minutes to watch the tension or tracking adjustments you made. Be patient, belt tracks slowly.
 6. Re-install roller bracket guards.

Adjusting Dust Scoop

The Model G1066R/G1079R is equipped with a dust scoop located next to the rear sanding drum. The Model G1066Z features a dust scoop for each drum. Dust scoops reduce the amount of dust that accumulates on the workpiece as it travels through the sander. Dust scoops are adjustable and should be set approximately $\frac{1}{32}$ " above the bottom of the drum for optimum effectiveness.

Item(s) Needed	Qty
Open-End or Socket Wrench 10mm	1
2x4 Gauge Block (2" x 4" x 24")	2

To adjust a dust scoop:

1. DISCONNECT MACHINE FROM POWER!
2. Place (2) gauge blocks of equal height under rear sanding drum and dust scoop. Raise table until gauge blocks just touch sanding drum.
3. Loosen dust scoop mounting bolts located at each end of scoop (see **Figure 44**).

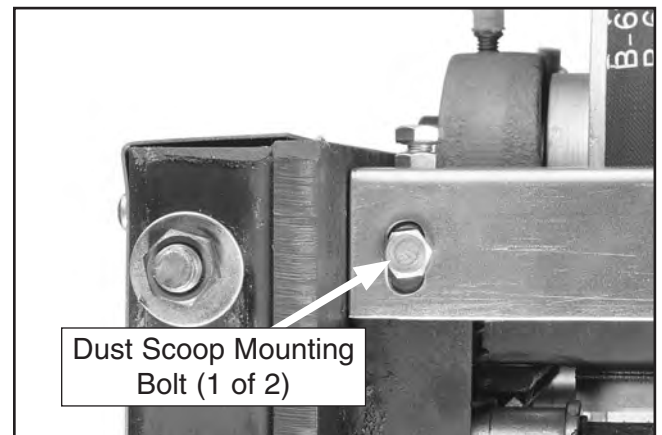

Figure 44. Location of dust scoop mounting bolts.

4. Move scoop up or down until it is approximately $\frac{1}{32}$ " above gauge blocks. Some flexing of sheet metal assembly may be needed to get the proper clearance. Retighten the mounting bolts and remove gauge blocks.



Tensioning/ Replacing V-Belts

Item(s) Needed	Qty
Open-End or Socket Wrench 17mm.....	1
Straightedge (at least 24")	1
Tape Measure.....	1
Phillips Screwdriver #2	1
Hex Wrench 5mm.....	1

Tension

New V-belts often stretch and loosen up during the first 16 hours of use. After this period, they should be inspected and re-tensioned if necessary. Replace V-belts if you notice fraying, cracking, glazing, or any other damage. A worn/damaged belt will not provide optimum power transfer from the motor to the drums.

The sanding drums are driven by two V-belts on the Model G1066R/G1066Z and one V-belt on the Model G1079R. The belts must have proper tension for optimum power transfer. However, too much tension may cause premature bearing failure. Proper tension is achieved when the belts deflect about $\frac{3}{4}$ " with moderate finger pressure at the midpoint between the drum pulley and the motor pulleys (see **Figure 45**).

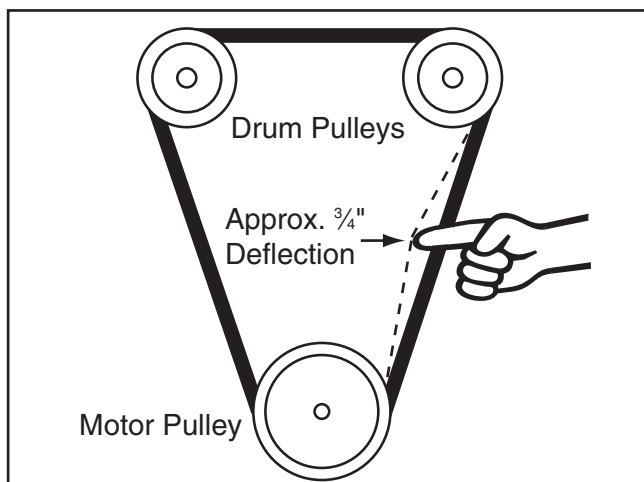

Figure 45. Proper V-belt deflection.

⚠ CAUTION

Always inspect V-belts for damage or deterioration when adjusting tension. Should you find evidence of fraying, cracking, or other damage, replace the belt immediately. Belt breakage could lead to mechanical damage or operator injury.

⚠ CAUTION

Belts and pulleys will be hot after operation. Allow them to cool before handling.

To adjust V-belt tension:

1. DISCONNECT MACHINE FROM POWER!
2. Remove right access panel.
3. Loosen motor mount fasteners shown in **Figure 46**. DO NOT completely remove motor mount fasteners.
4. Press down on motor to keep tension on belt.
5. Tighten motor mount fasteners (see **Figure 46**), and re-install right access panel.

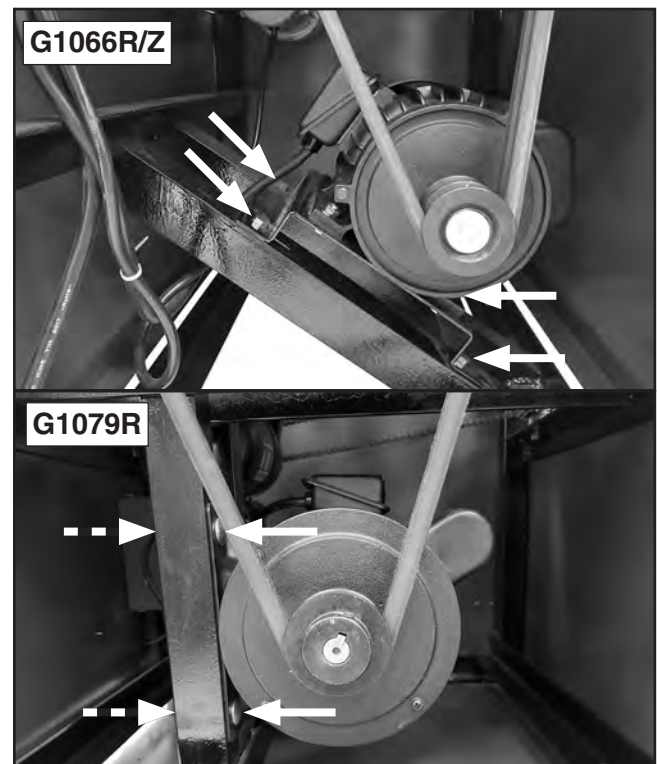

Figure 46. Locations of motor mount fasteners.



6. Check V-Belt tension. If necessary, repeat **Steps 3–5** until belt(s) is properly tensioned.
7. Re-install right access panel.

Removal/Replacement

Replace the V-belt if you notice fraying, cracking, glazing, or any other damage. A worn/damaged V-belt will not provide optimum power transmission from the motor to the drums.

V-belt removal and replacement is simply a matter of loosening the V-belts until you can roll them off the pulleys, replacing them with a **MATCHED** set, then re-tensioning them.

Note: *A matched set means both the V-belts are the same size and also have the same serial number.*

Pulley Alignment

Pulley alignment is another important factor in power transmission and belt life. The pulleys should be parallel to each other and in the same plane (coplaner) for optimum performance.

Each pulley can be adjusted by loosening the set screw that secures the pulley to the shaft, sliding the pulley in/out, and retightening the set screw to lock the pulley in place.

CAUTION

Belts and pulleys will be hot after operation. Allow them to cool before handling.

To align the pulleys:

1. **DISCONNECT MACHINE FROM POWER!**
2. Remove right access panel, loosen motor mount fasteners, and remove V-belts.
3. Place straightedge across face of motor pulley and front drum pulley to check alignment. The straightedge should sit evenly on top and bottom part of both pulleys.
4. Repeat **Step 3** with straightedge placed against motor pulley and rear drum pulley.
5. Loosen pulleys and adjust them as necessary until they are all coplanar with each other, and then tighten set screws.
6. Reinstall and properly tension V-belts, tighten motor mount fasteners, and reinstall right access panel.



Replacing Bearings

The Model G1066R/G1066Z/G1079R is designed for many years of reliable service. But after long periods of heavy use, it may be necessary to replace the pillow block bearings. Always replace both bearings on the same drum at the same time.

Item(s) Needed	Qty
Large, Round-Shaft Screwdriver	1
Bench Vise	1

1. DISCONNECT MACHINE FROM POWER!
2. Remove bearing housing from drum sander and clamp it tightly in a bench vise (see **Figure 47**).
3. Insert screwdriver into center hole of bearing (see **Figure 47**). Lever bearing until it turns perpendicular to the housing. Once bearing is turned 90° to housing, it should slide free with little effort. The housing is designed with notches that allow bearing to be inserted and removed. It is important that you lever bearing so it turns in alignment to those notches.

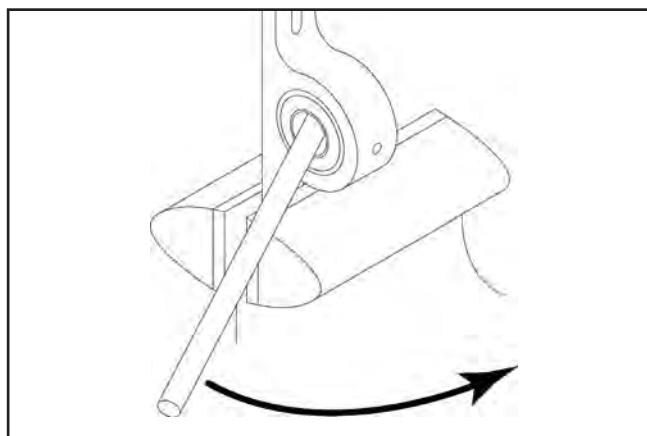

Figure 47. Detaching bearing from block.

4. Once old bearing is removed, clean bearing housing. Insert new bearing into notches in the housing (see **Figure 48**). After it reaches into housing as far as it will go, twist the bearing clockwise 90° (see **Figure 49**).

NOTICE

Make sure, when installing the new bearing, that lubrication groove in the bearing will match groove and grease fitting in housing once it is in place.

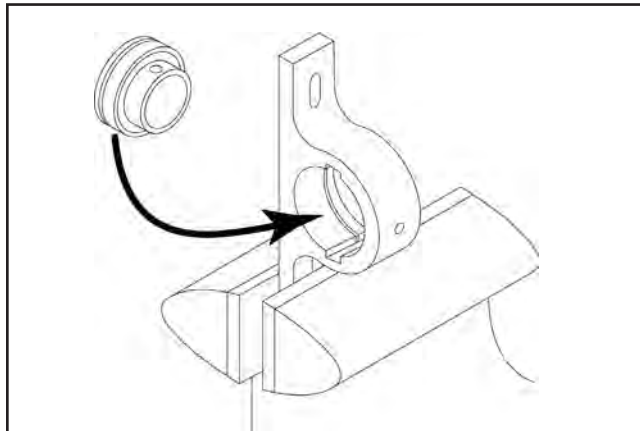

Figure 48. Matching bearing tab to notch.

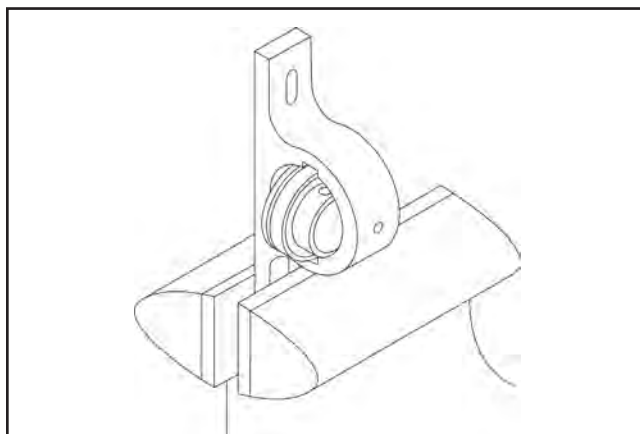

Figure 49. Inserting bearing into housing.

5. Insert screwdriver through bearing, as in **Step 3** and lever the bearing into its proper position in housing.
6. Press or tap bearing and housing back into place on the drum shaft. Re-adjust the drum as necessary.

NOTICE

Lubricate the bearings sparingly after about two months of sander operation. The bearing requires very little grease, so avoid the temptation to over-lubricate.



SECTION 8: WIRING

These pages are current at the time of printing. However, in the spirit of improvement, we may make changes to the electrical systems of future machines. Compare the manufacture date of your machine to the one stated in this manual, and study this section carefully.

If there are differences between your machine and what is shown in this section, call Technical Support at (570) 546-9663 for assistance BEFORE making any changes to the wiring on your machine. An updated wiring diagram may be available. **Note:** *Please gather the serial number and manufacture date of your machine before calling. This information can be found on the main machine label.*

WARNING

Wiring Safety Instructions

SHOCK HAZARD. Working on wiring that is connected to a power source is extremely dangerous. Touching electrified parts will result in personal injury including but not limited to severe burns, electrocution, or death. Disconnect the power from the machine before servicing electrical components!

MODIFICATIONS. Modifying the wiring beyond what is shown in the diagram may lead to unpredictable results, including serious injury or fire. This includes the installation of unapproved after-market parts.

WIRE CONNECTIONS. All connections must be tight to prevent wires from loosening during machine operation. Double-check all wires disconnected or connected during any wiring task to ensure tight connections.

CIRCUIT REQUIREMENTS. You MUST follow the requirements at the beginning of this manual when connecting your machine to a power source.

WIRE/COMPONENT DAMAGE. Damaged wires or components increase the risk of serious personal injury, fire, or machine damage. If you notice that any wires or components are damaged while performing a wiring task, replace those wires or components.

MOTOR WIRING. The motor wiring shown in these diagrams is current at the time of printing but may not match your machine. If you find this to be the case, use the wiring diagram inside the motor junction box.















CAPACITORS/INVERTERS. Some capacitors and power inverters store an electrical charge for up to 10 minutes after being disconnected from the power source. To reduce the risk of being shocked, wait at least this long before working on capacitors.

EXPERIENCING DIFFICULTIES. If you are experiencing difficulties understanding the information included in this section, contact our Technical Support at (570) 546-9663.

NOTICE

The photos and diagrams included in this section are best viewed in color. You can view these pages in color at www.grizzly.com.

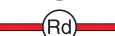
COLOR KEY

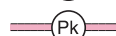
BLACK		BLUE		YELLOW		LIGHT BLUE	
WHITE		BROWN		YELLOW GREEN		BLUE WHITE	
GREEN		GRAY		PURPLE		TURQUOISE	
RED		ORANGE		PINK			



G1066R Electrical Components

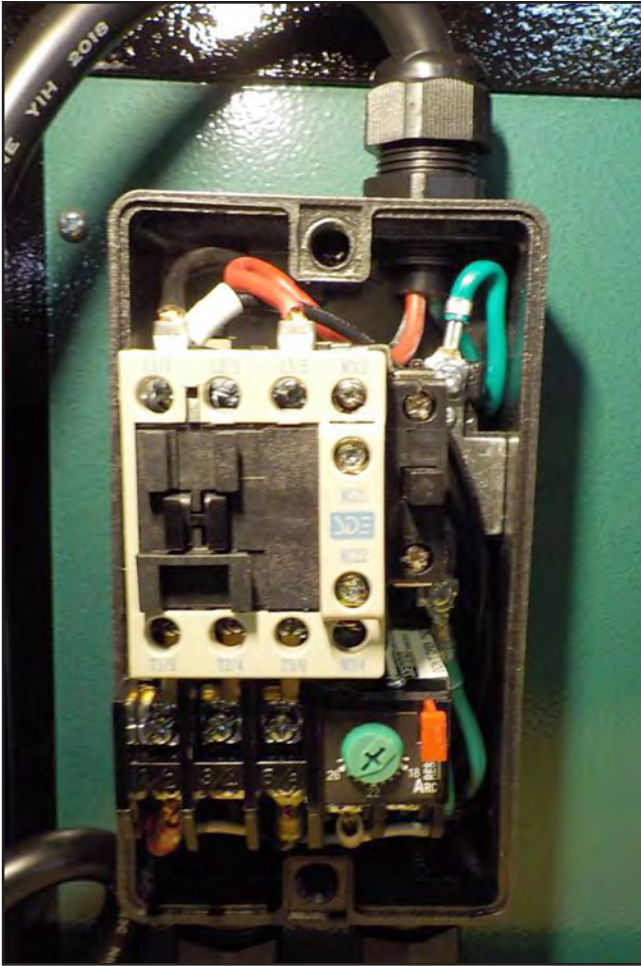

Figure 50. G1066R magnetic switch connections.



Figure 52. G1066R drum motor connections.

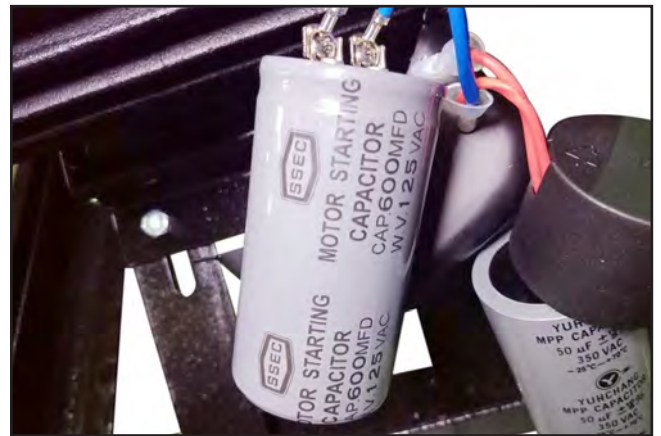

Figure 53. G1066R drum motor capacitors.

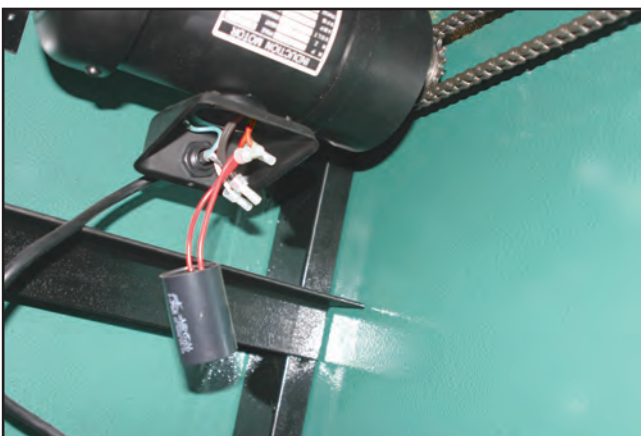
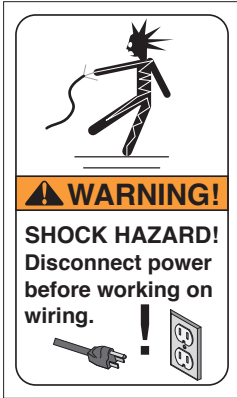

Figure 51. G1066R feed motor connections and capacitor.



G1066R Wiring Diagram



Ground
Hot
Hot
220 VAC
L6-30 PLUG
(As Recommended)

MAGNETIC
SWITCH
ASSEMBLY

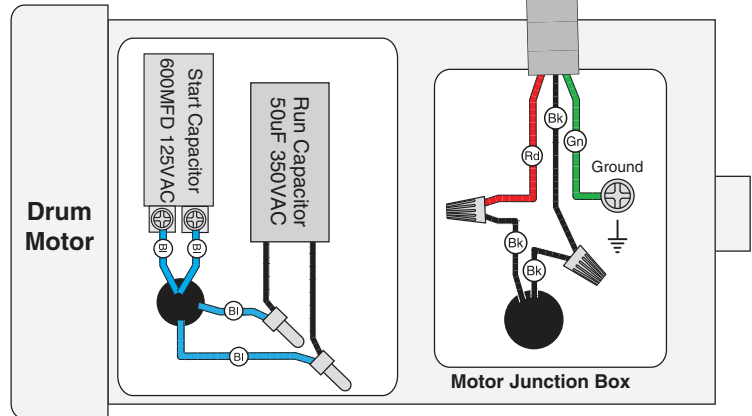
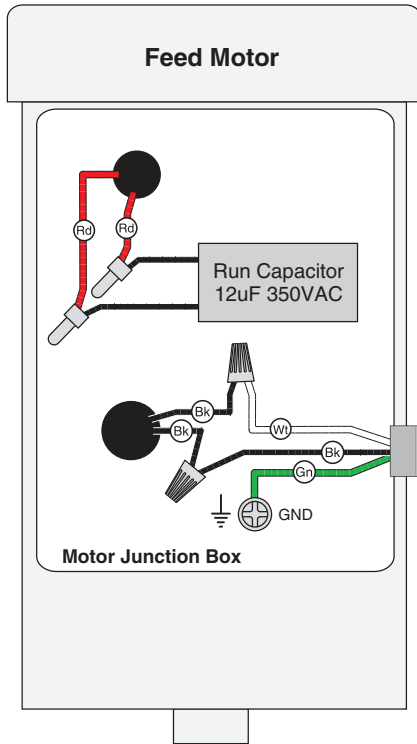
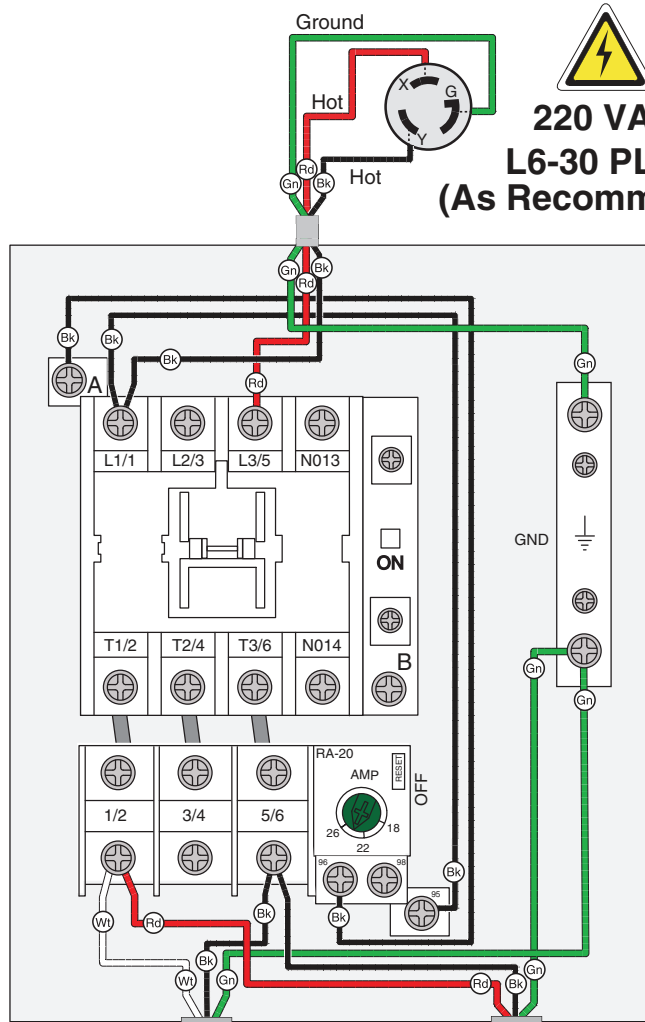

G1066Z Electrical Components



Figure 54. G1066Z feed motor connections and capacitors.

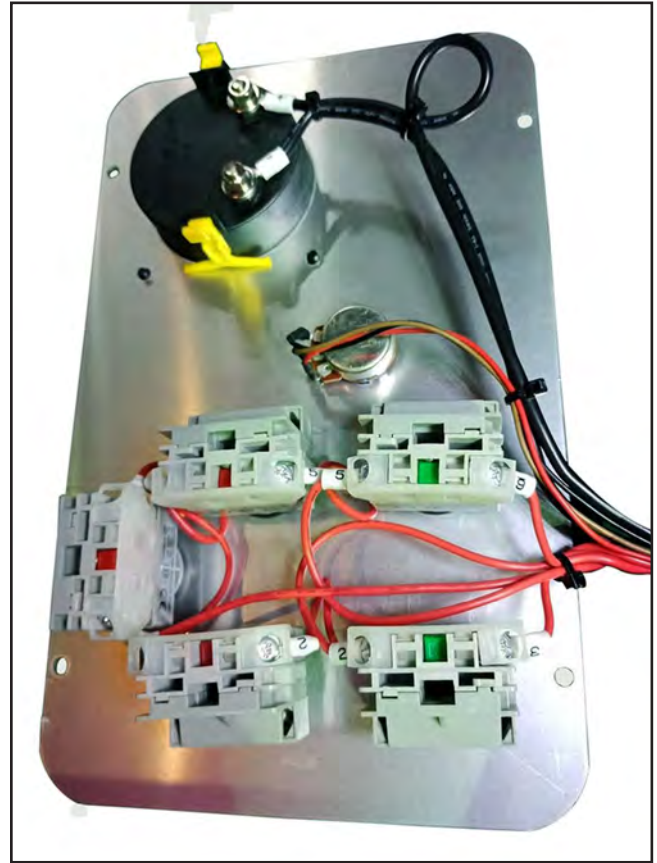

Figure 55. G1066Z controls connections (rotated 90°).

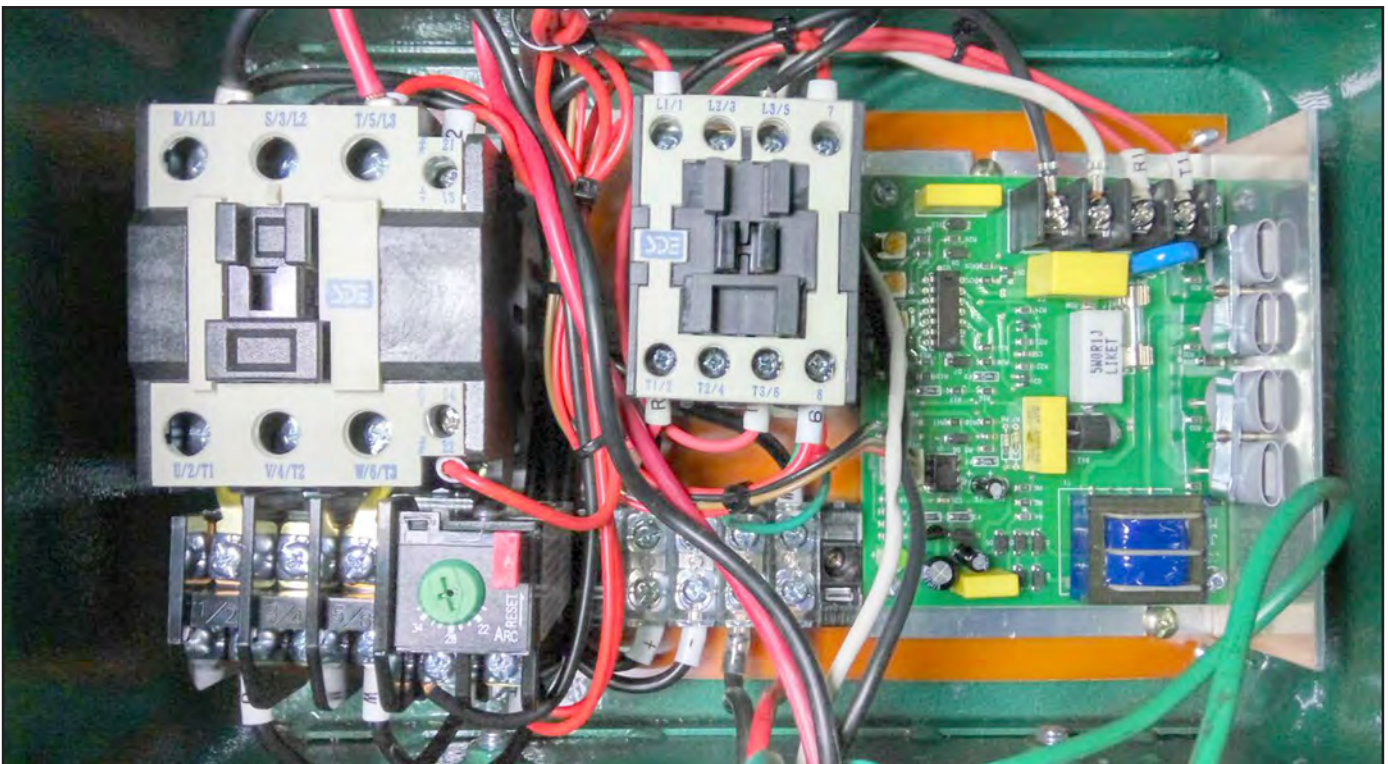
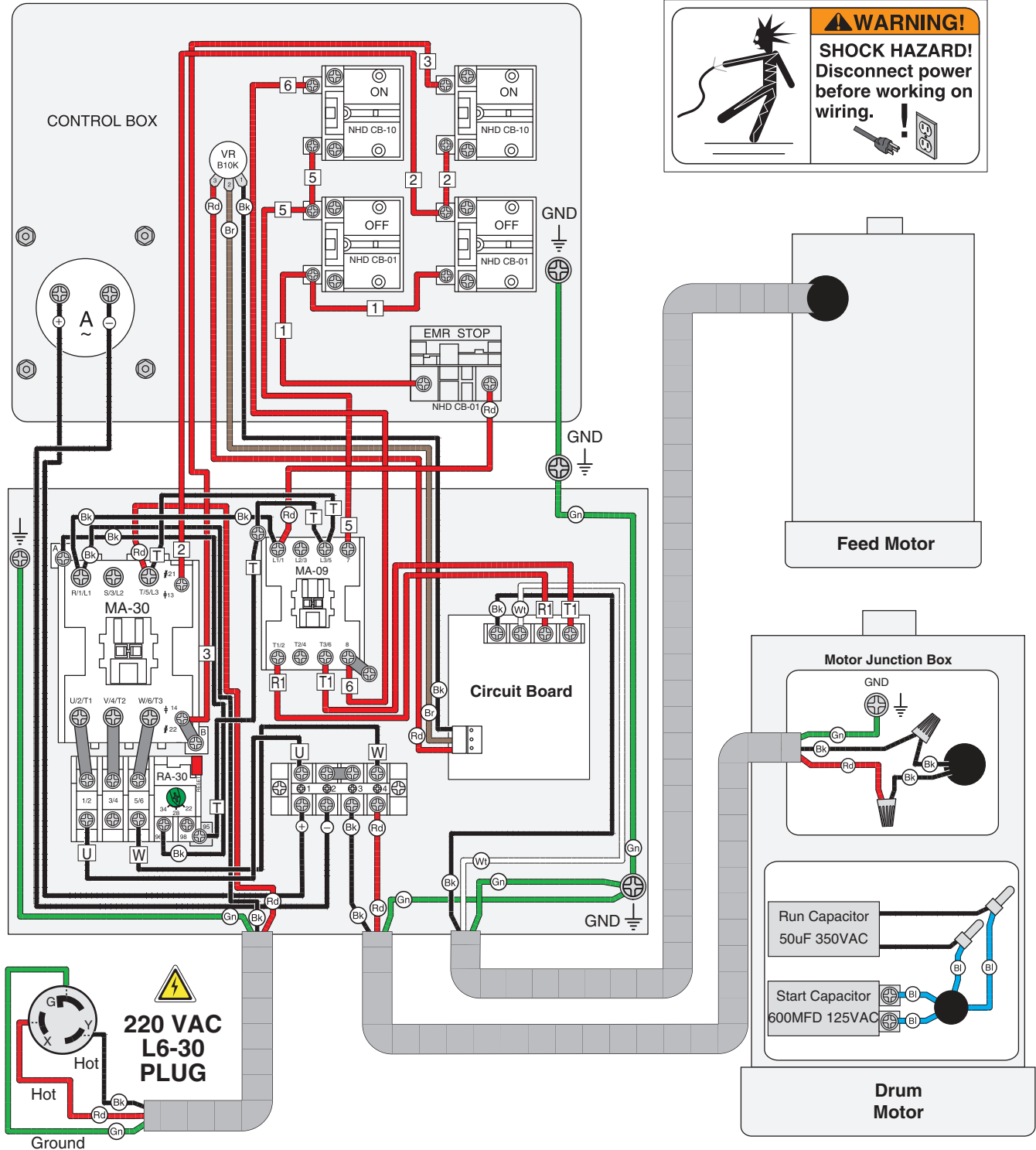

Figure 56. G1066Z control panel connections.



G1066Z Wiring Diagram



G1079R Electrical Components

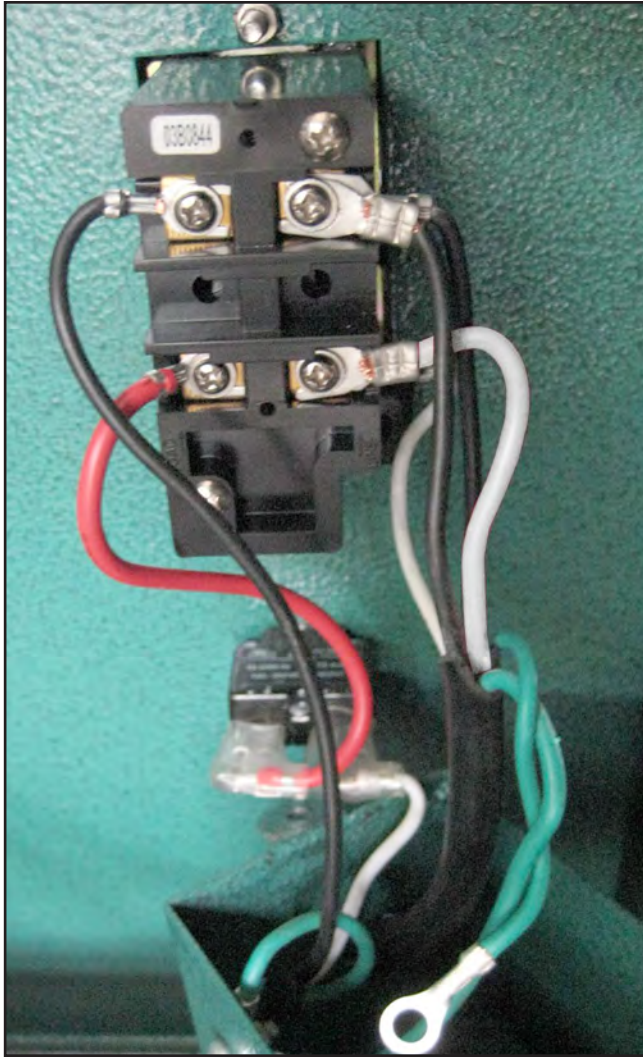

Figure 57. G1079R switch and circuit breaker connections.



Figure 59. G1079R drum motor connections.



Figure 60. G1079R drum motor start capacitor.

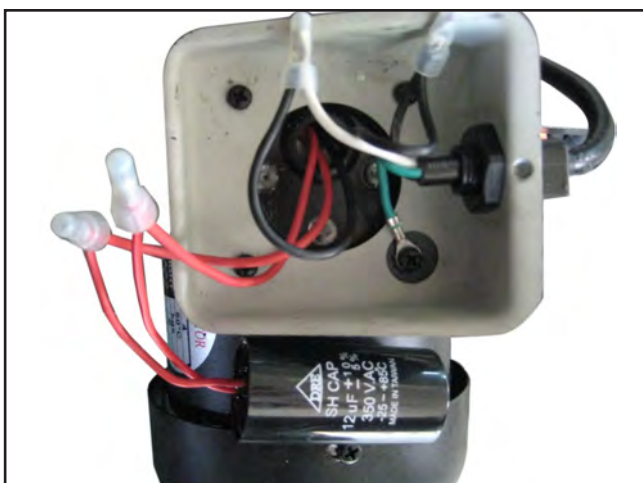
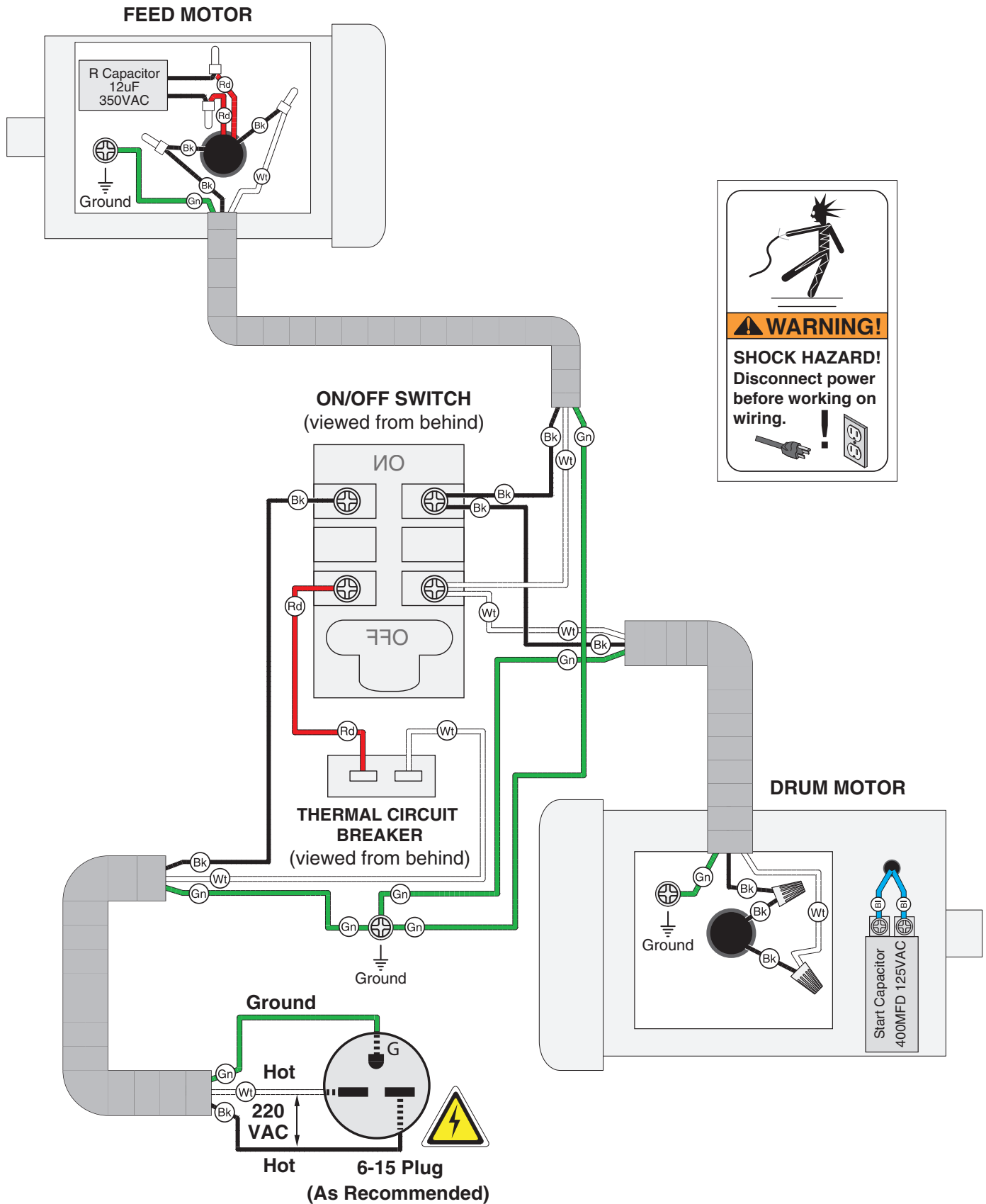

Figure 58. G1079R feed motor connections and run capacitor.



G1079R Wiring Diagram



SECTION 9: PARTS

G1066R Stand & Table Elevation

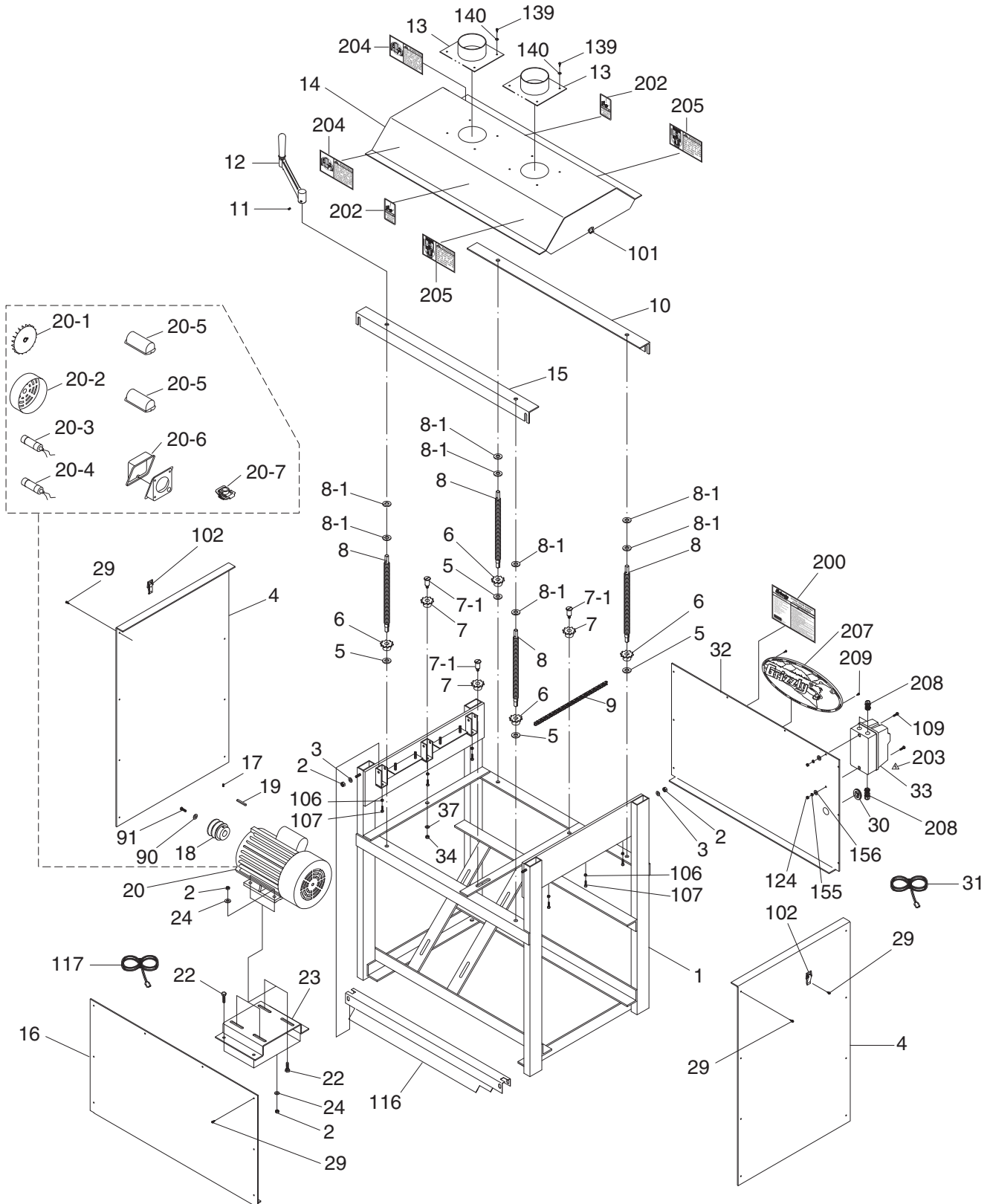

G1066R Conveyor Belt & Table

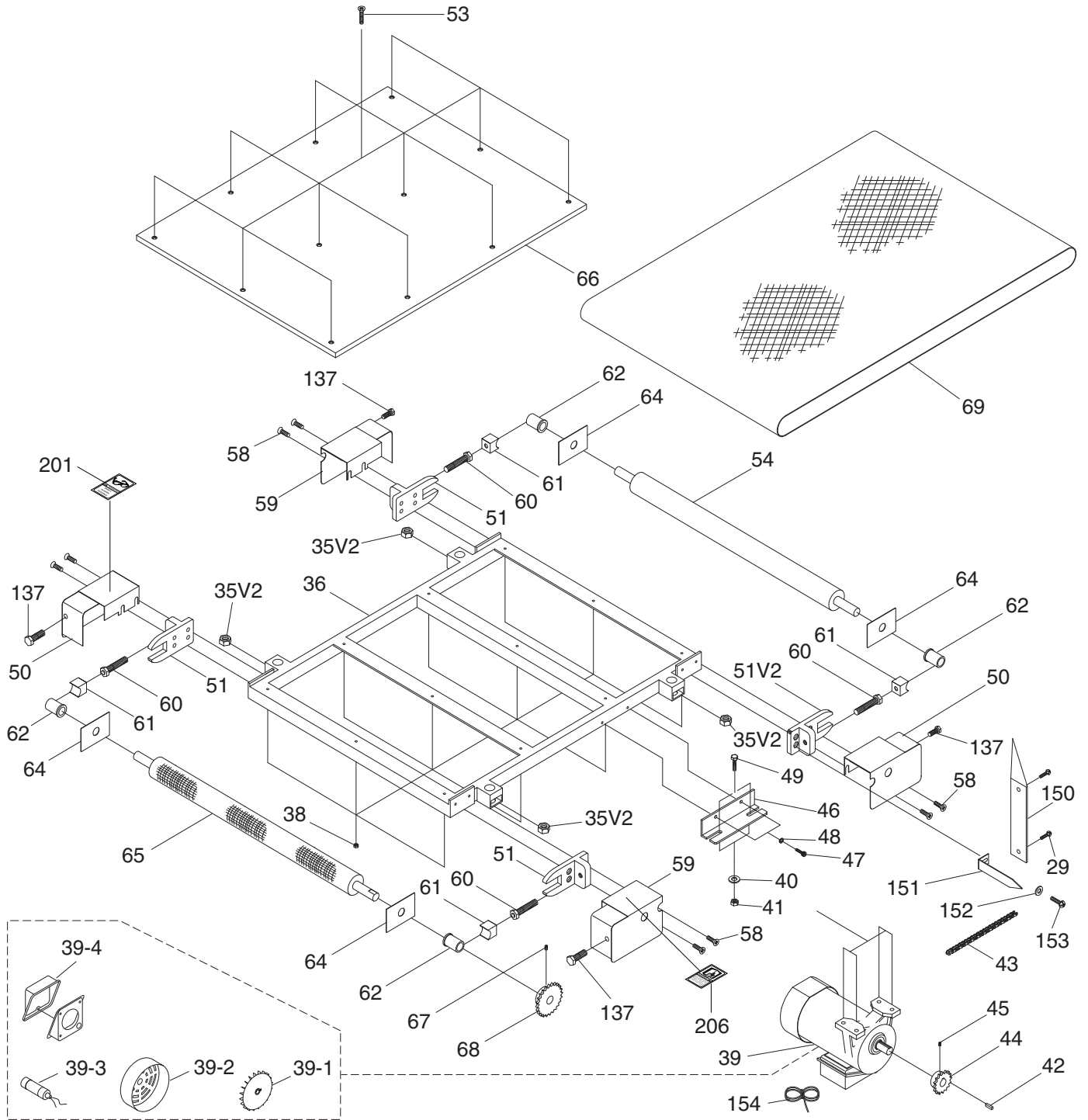

G1066R Drum & Roller Mechanism

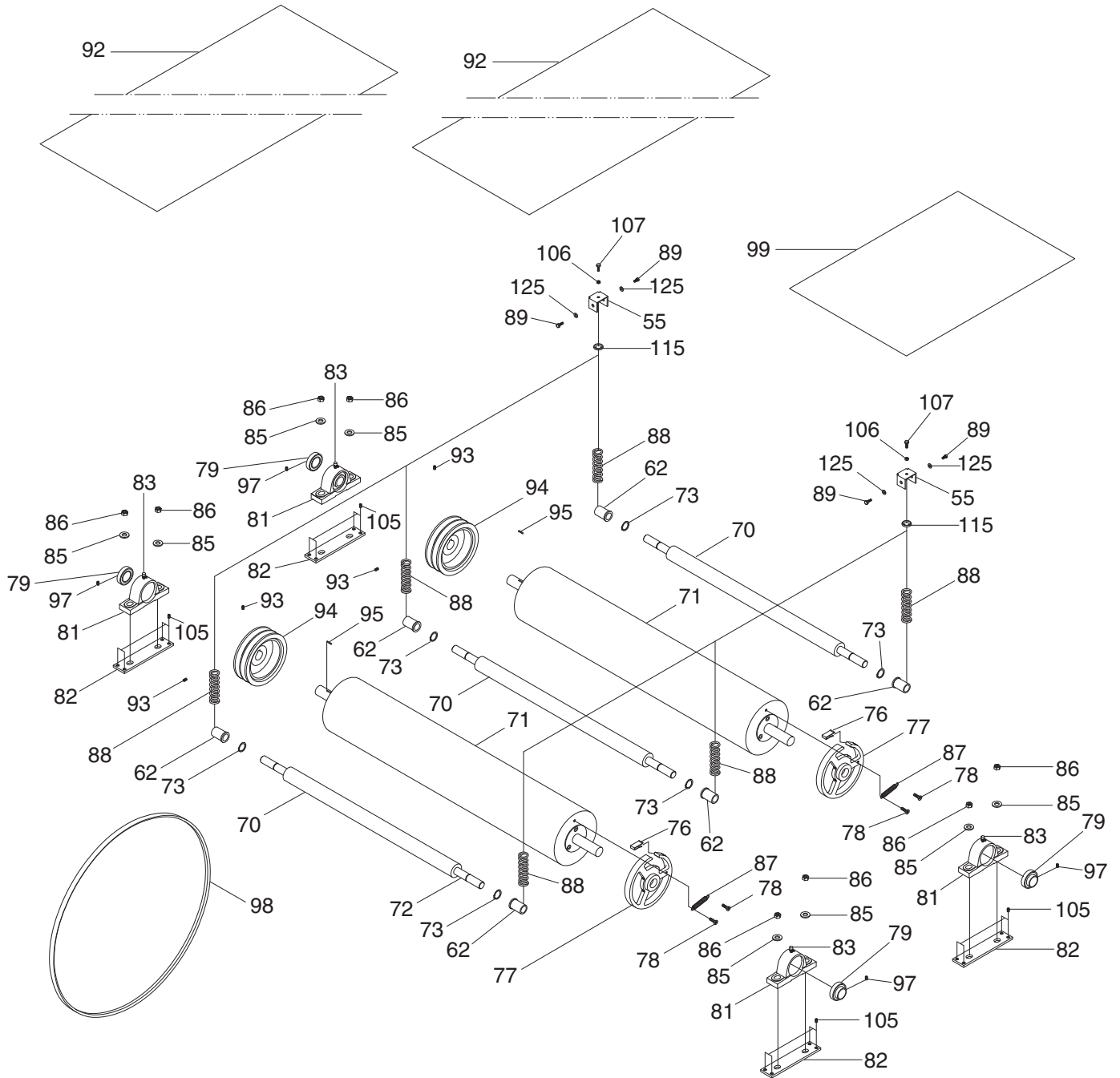

G1066R Parts List

REF	PART #	DESCRIPTION
1	P1066R001	FRAME
2	P1066R002	HEX NUT 3/8-16
3	P1066R003	FLAT WASHER 3/8
4	P1066R004	SIDE PANEL
5	P1066R005	BUSHING
6	P1066R006	SPROCKET
7	P1066R007	SPROCKET
7-1	P1066R007-1	SHAFT
8	P1066R008	TABLE SCREW FINE THREADS 3/4-16
8-1	P1066R008-1	TABLE SCREW SHIM 1/2 X 27 X 1
9	P1066R009	CHAIN
10	P1066R010	FRONT BRACE
11	P1066R011	SET SCREW 5/16-24 X 3/8
12	P1066R012	COMPLETE CRANK HANDLE ASSY
13	P1066R013	DUST HOOD
14	P1066R014	HOOD
15	P1066R015	REAR BRACE
16	P1066R016	REAR PANEL
17	P1066R017	SET SCREW 1/4-20 X 1/2
18	P1066R018	MOTOR PULLEY
19	P1066R019	KEY 1/4 X 1/4 X 3
20	P1066R020	DRUM MOTOR 5HP 220V 1-PH
20-1	P1066R020-1	MOTOR FAN
20-2	P1066R020-2	MOTOR FAN COVER
20-3	P1066R020-3	S CAPACITOR 600M 125V 1-3/4 X 3-3/8
20-4	P1066R020-4	R CAPACITOR 50M 350V 1-3/4 X 3-3/8
20-5	P1066R020-5	CAPACITOR COVER
20-6	P1066R020-6	JUNCTION BOX
20-7	P1066R020-7	CENTRIFUGAL SWITCH
22	P1066R022	HEX BOLT 3/8-16 X 1
23	P1066R023	BRACKET
24	P1066R024	FLAT WASHER 3/8
29	P1066R029	TAP SCREW #6 X 1/2
30	P1066R030	GROMMET 35 X 26MM
31	P1066R031	POWER CORD 12G 3W 86"
32	P1066R032	FRONT PANEL
33	P1066R033	5 HP MAGNETIC SWITCH SINGLE-PHASE
34	P1066R034	HEX NUT 5/16-18
35V2	P1066R035V2	HEX NUT 3/4-16 1-1/4" DIA V2.08.02
36	P1066R036	TABLE FRAME
37	P1066R037	FLAT WASHER 5/16
38	P1066R038	LOCK NUT 1/4-20
39	P1066R039	FEED MOTOR 1/4HP 220V 1-PH
39-1	P1066R039-1	MOTOR FAN
39-2	P1066R039-2	MOTOR FAN COVER
39-3	P1066R039-3	R CAPACITOR 12M 350V 1-3/8 X 2
39-4	P1066R039-4	JUNCTION BOX
40	P1066R040	FLAT WASHER 5/16
41	P1066R041	HEX NUT 5/16-18
42	P1066R042	KEY 5 X 5 X 20
43	P1066R043	CHAIN
44	P1066R044	SPROCKET
45	P1066R045	SET SCREW 1/4-20 X 1/4
46	P1066R046	MOTOR BRACKET
47	P1066R047	CAP SCREW 3/8-16 X 3/4

REF	PART #	DESCRIPTION
48	P1066R048	FLAT WASHER 1/4
49	P1066R049	HEX BOLT 5/16-18 X 1
50	P1066R050	GUARD HINGED LEFT
51	P1066R051	ROLLER BRACKET
51V2	P1066R051V2	ROLLER BRACKET V2.02.11
53	P1066R053	FLAT HD SCR 1/4-20 X 2-3/8
54	P1066R054	IDLE ROLLER SMOOTH 24 IN
55	P1066R055	BRACKET
58	P1066R058	CAP SCREW 1/4-20 X 3/4
59	P1066R059	GUARD RIGHT
60	P1066R060	ROLLER BRACKET BOLT 1/2-13 X 70
61	P1066R061	BUSHING SUPPORT
62	P1066R062	BUSHING
64	P1066R064	PLATE
65	P1066R065	DRIVE ROLLER KNURLED 24 IN
66	P1066R066	TABLE 12 HOLE
67	P1066R067	SET SCREW 1/4-20 X 1/2
68	P1066R068	SPROCKET 24T
69	P1066R069	RUBBER CONVEYOR BELT
70	P1066R070	PRESSURE ROLLER
71	P1066R071	SANDING DRUM
73	P1066R073	EXT RETAINING RING 19MM
76	P1066R076	CLIP
77	P1066R077	TENSION WHEEL
78	P1066R078	FLAT HD ALLEN SCR 1/4-20 X 1/2
79	P1066R079	PILLOW BLOCK BEARING UCP205
81	P1066R081	BEARING BLOCK
82	P1066R082	BEARING BLOCK PLATE, TAPPED
83	P1066R083	GREASE FITTING M6-1 X 5
85	P1066R085	FLAT WASHER 3/8
86	P1066R086	LOCK NUT 3/8-16
87	P1066R087	TENSION SPRING
88	P1066R088	COMPRESSION SPRING
89	P1066R089	HEX BOLT M6-1 X 8
90	P1066R090	FLAT WASHER 3/8
91	P1066R091	HEX BOLT M8-1.25 X 24
92	P1066R092	SANDING ROLL 6" x 50' A60-X CLOTH
93	P1066R093	SET SCREW 1/4-20 X 1/2
94	P1066R094	DRUM PULLEY
95	P1066R095	KEY 6 X 6 X 30
97	P1066R097	SET SCREW M6-1 X 8
98	P1066R098	V-BELT B67
99	P1066R099	FELT 19 X 24 IN
101	P1066R101	STRIKE
102	P1066R102	LATCH
105	P1066R105	SET SCREW 5/16-24 X 5/8
106	P1066R106	HEX NUT 1/4-20
107	P1066R107	HEX BOLT 1/4-20 X 1/2
109	P1066R109	PHLP HD SCR 10-24 X 5/8
115	P1066R115	SPRING PLATE
116	P1066R116	DUST SCOOP DEFLECTOR
117	P1066R117	MOTOR CORD 12G 3W 36"
124	P1066R124	HEX NUT 10-24
125	P1066R125	FLAT WASHER 1/4
137	P1066R137	PHLP HD SCR 10-24 X 3/8



G1066R Parts List (Cont.)

REF	PART #	DESCRIPTION
139	P1066R139	TAP SCREW #8 X 1/2
140	P1066R140	FLAT WASHER #10
150	P1066R150	DEPTH SCALE
151	P1066R151	SCALE POINTER
152	P1066R152	FLAT WASHER 1/4
153	P1066R153	PHLP HD SCR 1/4-20 X 3/8
154	P1066R154	FEED MOTOR CORD 18G 3W 36"
155	P1066R155	EXT TOOTH WASHER #10
156	P1066R156	LOCK WASHER #10
200	P1066R200	ID/WARNING LABEL

REF	PART #	DESCRIPTION
201	P1066R201	SAFETY GLASSES LABEL
202	P1066R202	UNPLUG LABEL
203	P1066R203	ELECTRICITY LABEL
204	P1066R204	FEED ONE PIECE LABEL
205	P1066R205	DON'T STAND BEHIND LABEL
206	P1066R206	READ MANUAL LABEL
207	P1066R207	GRIZZLY NAMEPLATE
208	P1066R208	STRAIN RELIEF TYPE-3 PG20
209	P1066R209	TAP SCREW #8 X 5/8



G1066Z Stand & Table Elevation

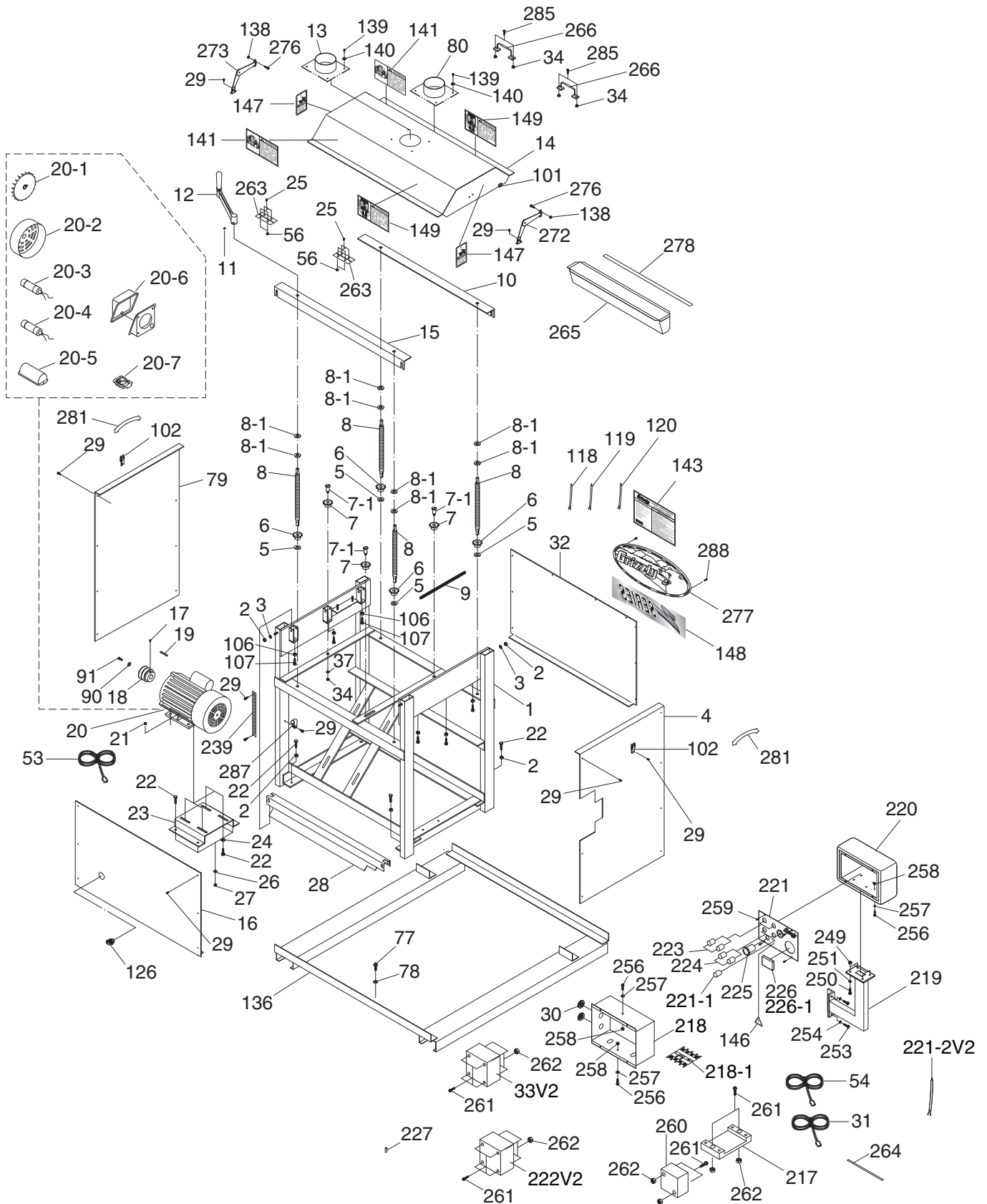

G1066Z Conveyor Belt & Table

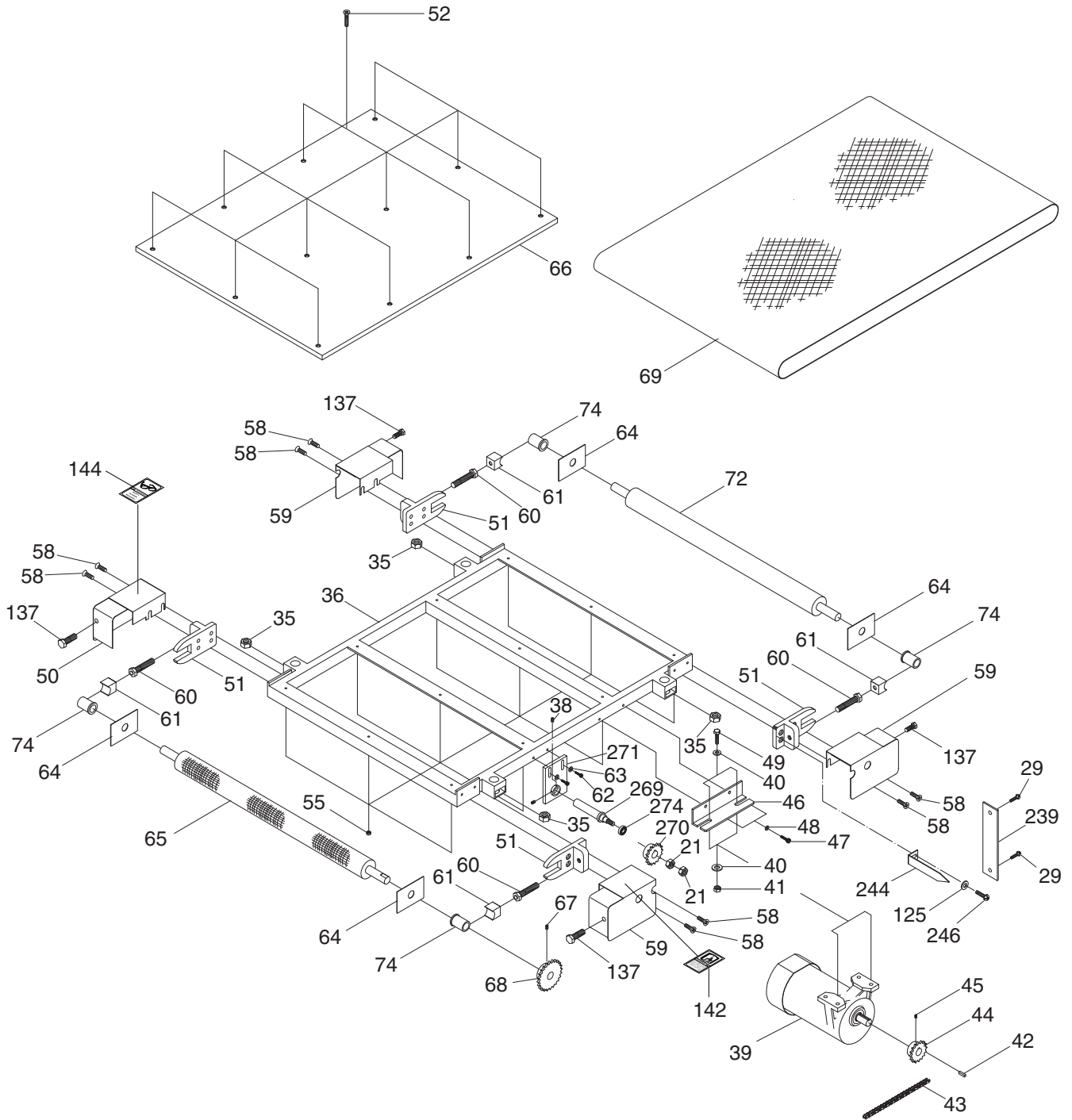

G1066Z Drum & Roller Mechanism

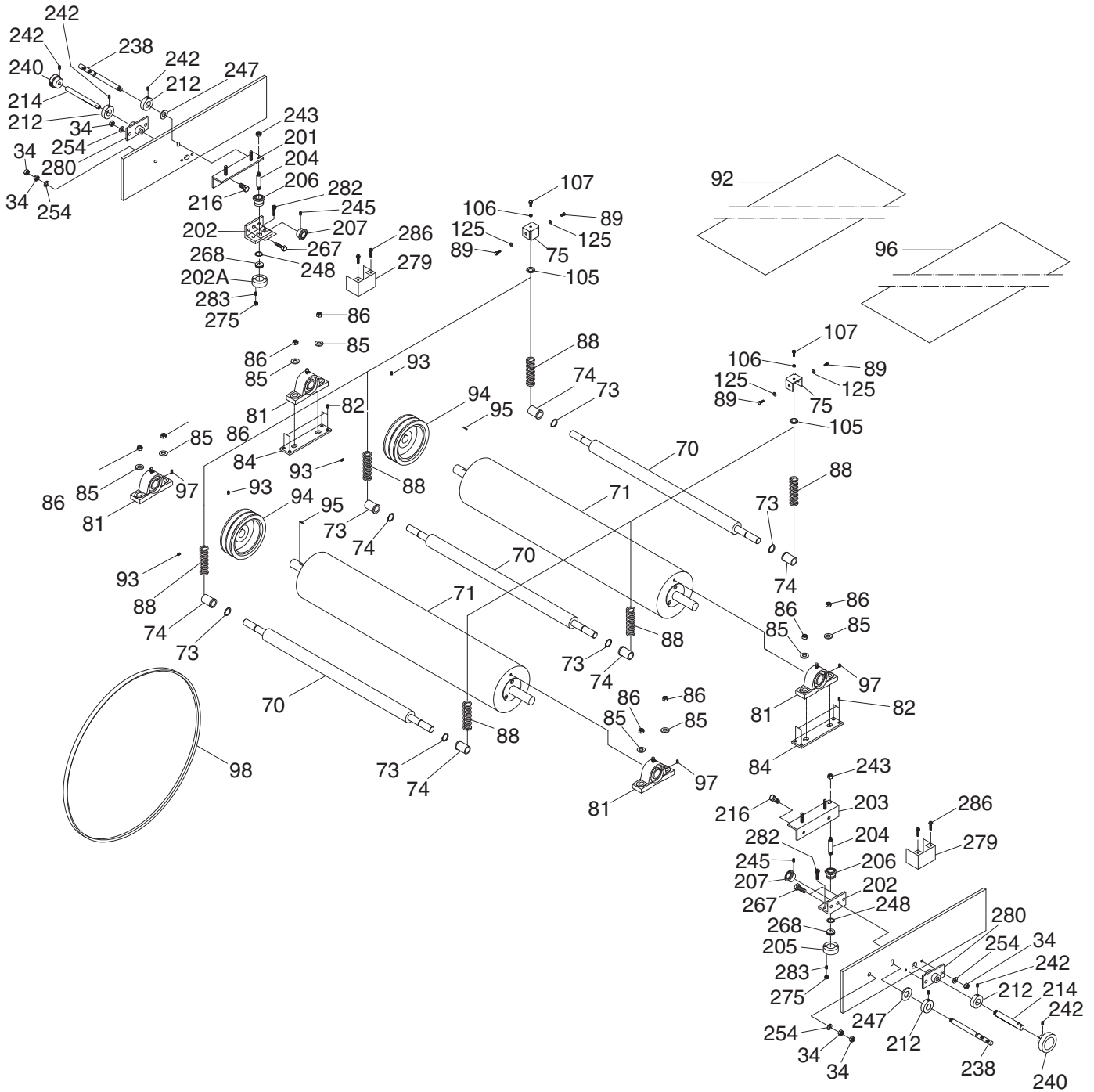

G1066Z Parts List

REF	PART #	DESCRIPTION
1	P1066Z001	FRAME
2	P1066Z002	HEX NUT 3/8-16
3	P1066Z003	FLAT WASHER 3/8
4	P1066Z004	SIDE PANEL
5	P1066Z005	FLAT WASHER 1/2
6	P1066Z006	SPROCKET
7	P1066Z007	SPROCKET
7-1	P1066Z007-1	SHAFT
8	P1066Z008	TABLE SCREW FINE THREADS 3/4-16
8-1	P1066Z008-1	TABLE SCREW SHIM 1/2 X 27 X 1
9	P1066Z009	CHAIN
10	P1066Z010	FRONT BRACE
11	P1066Z011	SET SCREW 5/16-24 X 3/8
12	P1066Z012	COMPLETE CRANK HANDLE ASSY
13	P1066Z013	DUST HOOD
14	P1066Z014	HOOD
15	P1066Z015	REAR BRACE
16	P1066Z016	REAR PANEL
17	P1066Z017	SET SCREW 1/4-20 X 1/2
18	P1066Z018	MOTOR PULLEY
19	P1066Z019	KEY 5 X 5 X 25
20	P1066Z020	DRUM MOTOR 5HP 220V 1-PH
20-1	P1066Z020-1	MOTOR FAN
20-2	P1066Z020-2	MOTOR FAN COVER
20-3	P1066Z020-3	S CAPACITOR 600M 125V 1-3/4 X 3-3/8
20-4	P1066Z020-4	R CAPACITOR 50M 350V 1-3/4 X 3-3/8
20-5	P1066Z020-5	CAPACITOR COVER
20-6	P1066Z020-6	JUNCTION BOX
20-7	P1066Z020-7	CENTRIFUGAL SWITCH
21	P1066Z021	HEX NUT 3/8-16
22	P1066Z022	HEX BOLT 3/8-16 X 1
23	P1066Z023	BRACKET
24	P1066Z024	FLAT WASHER 3/8
25	P1066Z025	PHLP HD SCR M4-.7 X 10
26	P1066Z026	FLAT WASHER 3/8
27	P1066Z027	HEX NUT 3/8-16
28	P1066Z028	DUST DEFLECTOR
29	P1066Z029	TAP SCREW #8 X 3/8
30	P1066Z030	GROMMET 29 X 25MM
31	P1066Z031	POWER CORD 12G 3W 86"
32	P1066Z032	FRONT PANEL
33V2	P1066Z033V2	CONTACTOR SDE MA-30 240V V2.05.16
34	P1066Z034	HEX NUT 5/16-18
35	P1066Z035	HEX NUT 3/4-16 1-1/4" DIA
36	P1066Z036	TABLE FRAME
37	P1066Z037	FLAT WASHER 5/16
38	P1066Z038	SET SCREW 3/8-16 X 1/4
39	P1066Z039	FEED BELT MOTOR 1/3HP 60V 1-PH
40	P1066Z040	FLAT WASHER 5/16
41	P1066Z041	HEX NUT 5/16-18
42	P1066Z042	KEY 5 X 5 X 20
43	P1066Z043	CHAIN
44	P1066Z044	SPROCKET

REF	PART #	DESCRIPTION
45	P1066Z045	SET SCREW 1/4-20 X 1/4
46	P1066Z046	MOTOR BRACKET
47	P1066Z047	CAP SCREW 1/4-20 X 3/4
48	P1066Z048	FLAT WASHER 1/4
49	P1066Z049	HEX BOLT 5/16-18 X 1-1/4
50	P1066Z050	GUARD HINGED LEFT
51	P1066Z051	ROLLER BRACKET
52	P1066Z052	FLAT HD SCR 1/4-20 X 1
53	P1066Z053	POWER CORD 12G 3W 36"
54	P1066Z054	POWER CORD 12G 3W 36"
55	P1066Z055	LOCK NUT 1/4-20
56	P1066Z056	LOCK NUT M4-.7
58	P1066Z058	CAP SCREW 1/4-20 X 3/4
59	P1066Z059	GUARD RIGHT
60	P1066Z060	ROLLER BRACKET BOLT 1/2-13 X 70
61	P1066Z061	BUSHING SUPPORT
62	P1066Z062	HEX BOLT 1/4-20 X 1/4
63	P1066Z063	FLAT WASHER 1/4
64	P1066Z064	PLATE
65	P1066Z065	DRIVE ROLLER KNURLED 24 IN
66	P1066Z066	TABLE 12 HOLE
67	P1066Z067	SET SCREW 5/16-18 X 1/2
68	P1066Z068	SPROCKET
69	P1066Z069	RUBBER CONVEYOR BELT
70	P1066Z070	PRESSURE ROLLER
71	P1066Z071	SANDING DRUM
72	P1066Z072	IDLE ROLLER SMOOTH 24 IN
73	P1066Z073	EXT RETAINING RING 19MM
74	P1066Z074	BUSHING
75	P1066Z075	BRACKET
77	P1066Z077	FLAT WASHER 1/4
78	P1066Z078	TAP SCREW 1/4 X 1-1/2
79	P1066Z079	SIDE PANEL
80	P1066Z080	DUST HOOD
81	P1066Z081	BEARING BLOCK SET
82	P1066Z082	SET SCREW 5/16-24 X 1/2
84	P1066Z084	BEARING BLOCK PLATE, TAPPED
85	P1066Z085	FLAT WASHER 3/8
86	P1066Z086	LOCK NUT 3/8-16
88	P1066Z088	COMPRESSION SPRING
89	P1066Z089	HEX BOLT 1/4-20 X 3/8
90	P1066Z090	FLAT WASHER 3/8
91	P1066Z091	HEX BOLT M8-1.25 X 24
92	P1066Z092	SANDING ROLL 3" x 50' A60 H&L
93	P1066Z093	SET SCREW 3/8-16 X 1/2
94	P1066Z094	DRUM PULLEY
95	P1066Z095	KEY 1/4 X 1/4 X 1-1/4
96	P1066Z096	SANDING ROLL 3" x 50' A100 H&L
97	P1066Z097	SET SCREW M6-1 X 6
98	P1066Z098	V-BELT B67
101	P1066Z101	STRIKE
102	P1066Z102	LATCH
105	P1066Z105	SPRING PLATE



G1066Z Parts List (Cont.)

REF	PART #	DESCRIPTION
106	P1066Z106	HEX NUT 1/4-20
107	P1066Z107	HEX BOLT 1/4-20 X 5/8
118	P1066Z118	LINE CORD
119	P1066Z119	LINE CORD
120	P1066Z120	EARTH LEAD GREEN
125	P1066Z125	FLAT WASHER 1/4
126	P1066Z126	STRAIN RELIEF TYPE-3 PG20
136	P1066Z136	BASE STEEL CRATE
137	P1066Z137	PHLP HD SCR 10-24 X 3/8
138	P1066Z138	HEX NUT M4-.7
139	P1066Z139	TAP SCREW #8 X 1/2
140	P1066Z140	FLAT WASHER #10
141	P1066Z141	SANDER BELT PINCH LABEL
142	P1066Z142	READ MANUAL LABEL
143	P1066Z143	ID/WARNING LABEL
144	P1066Z144	SAFETY GLASSES LABEL
145	P1066Z145	DISCONNECT SANDER LABEL
146	P1066Z146	ELECTRICITY LABEL
147	P1066Z147	SANDER BELT PINCH LABEL
148	P1066Z148	Z SERIES LABEL
149	P1066Z149	FEED ONLY ONE LABEL
201	P1066Z201	BEARING SEAT LEFT
202	P1066Z202	MOUNTING BRACKET
203	P1066Z203	BEARING SEAT RIGHT
204	P1066Z204	MICRO ADJUST SCREW
205	P1066Z205	THRUST BEARING SEAT
206	P1066Z206	BEVEL GEAR A
207	P1066Z207	BEVEL GEAR B
212	P1066Z212	LOCK COLLAR
214	P1066Z214	DRIVE SHAFT
216	P1066Z216	RIGHT BEARING SEAT BOLT 5/16-18 X 1/2
217	P1066Z217	WIRING PANEL
218	P1066Z218	MAG SWITCH BOX
218-1	P1066Z218-1	TERMINAL BLOCK
219	P1066Z219	PEDESTAL ARM
220	P1066Z220	CONTROL BOX
221	P1066Z221	CONTROL PANEL
221-1	P1066Z221-1	FEED RATE SWITCH
221-2V2	P1066Z221-2V2	COMP CONTROL WIRE HARNESS V2.10.08
222V2	P1066Z222V2	CONTACTOR SDE MA-09 240V V2.06.13
223	P1066Z223	ON SWITCH NHD CB-10
224	P1066Z224	OFF SWITCH NHD CB-01
225	P1066Z225	E-STOP BUTTON NHD CB-01
226	P1066Z226	LOAD/AMP METER
226-1	P1066Z226-1	LOAD/AMP METER COVER
227	P1066Z227	CABLE MARKER
238	P1066Z238	LOCK HANDLE

REF	PART #	DESCRIPTION
239	P1066Z239	SCALE
240	P1066Z240	CONTROL KNOB
242	P1066Z242	SET SCREW 1/4-20 X 5/16
243	P1066Z243	LOCK NUT 1/4-20
244	P1066Z244	POINTER
245	P1066Z245	SET SCREW 10-24 X 1/4
246	P1066Z246	PHLP HD SCR 1/4-20 X 3/8
247	P1066Z247	FLAT WASHER 5/16
248	P1066Z248	EXT RETAINING RING 20MM
249	P1066Z249	HEX NUT 1/4-20
250	P1066Z250	HEX BOLT 1/4-20 X 3/4
251	P1066Z251	FLAT WASHER 1/4
253	P1066Z253	HEX BOLT 5/16-18 X 1
254	P1066Z254	FLAT WASHER 5/16
256	P1066Z256	PHLP HD SCR 10-24 X 1/2
257	P1066Z257	FLAT WASHER #10
258	P1066Z258	HEX NUT 10-24
259	P1066Z259	TAP SCREW #10 X 3/8
260	P1066Z260	VARIABLE SPEED CIRCUIT BOARD
261	P1066Z261	PHLP HD SCR 10-24 X 5/8
262	P1066Z262	HEX NUT 10-24
263	P1066Z263	HINGE
264	P1066Z264	NYLON CABLE TIES
265	P1066Z265	AIR DUST SCOOP
266	P1066Z266	HANDLE
267	P1066Z267	CAP SCREW 5/16-18 X 1-1/4
268	P1066Z268	THRUST BEARING 51101
269	P1066Z269	SPROCKET SHAFT
270	P1066Z271	SPROCKET
271	P1066Z271	ADJUSTMENT PLATE
272	P1066Z272	SUPPORT ARM LEFT
273	P1066Z273	SUPPORT ARM RIGHT
274	P1066Z274	BALL BEARING 6201-2RS
275	P1066Z275	HEX NUT 10-24
276	P1066Z276	PHLP HD SCR M4-.7 X 6
277	P1066Z277	NAMEPLATE
278	P1066Z278	SELF ADHESIVE FOAM 660 X 15 X 2MM
279	P1066Z279	DUST COVER
280	P1066Z280	DRIVE SHAFT BRACKET
281	P1066Z281	DIRECTION LABEL
282	P1066Z282	CAP SCREW 1/4-20 X 5/8
283	P1066Z283	SET SCREW 10-24 X 1/2
285	P1066Z285	CAP SCREW 5/16-18 X 3/4
286	P1066Z286	TAP SCREW #10 X 3/8
287	P1066Z287	CORD RETAINER CLIP
288	P1066Z288	TAP SCREW #8 X 5/8



G1079R Stand & Table Elevation

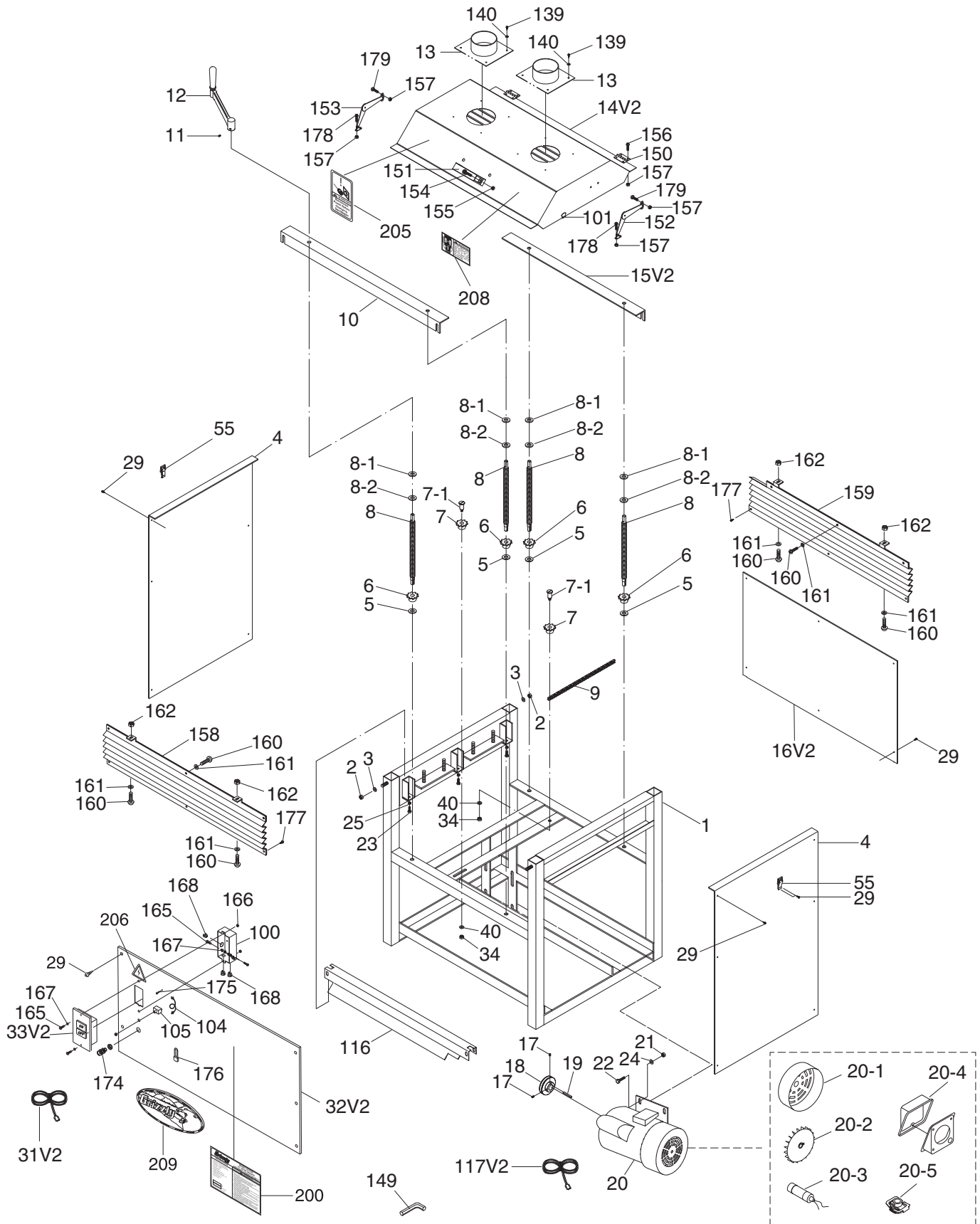

G1079R Conveyor Belt & Table

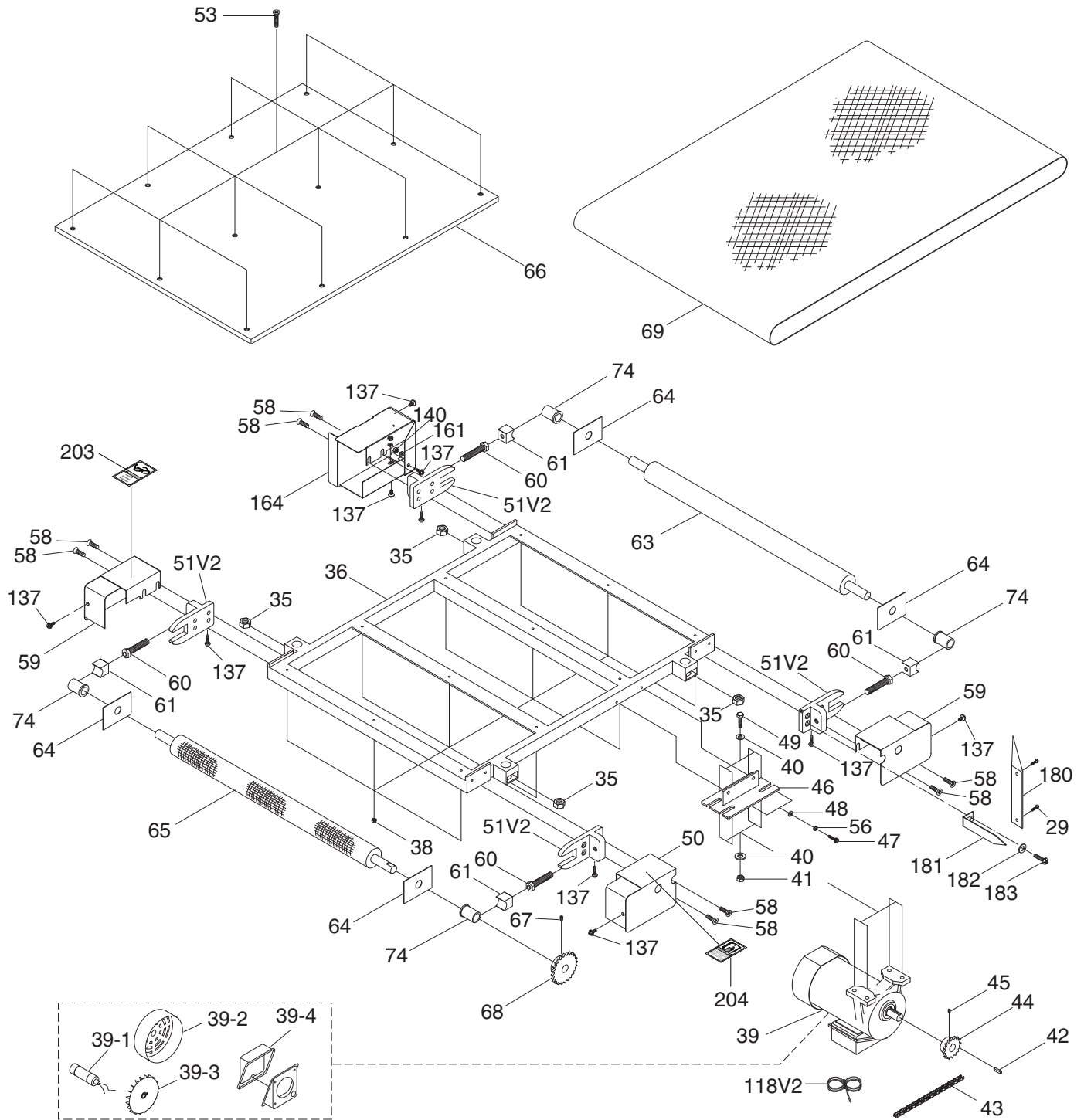

G1079R Drum & Roller Mechanism

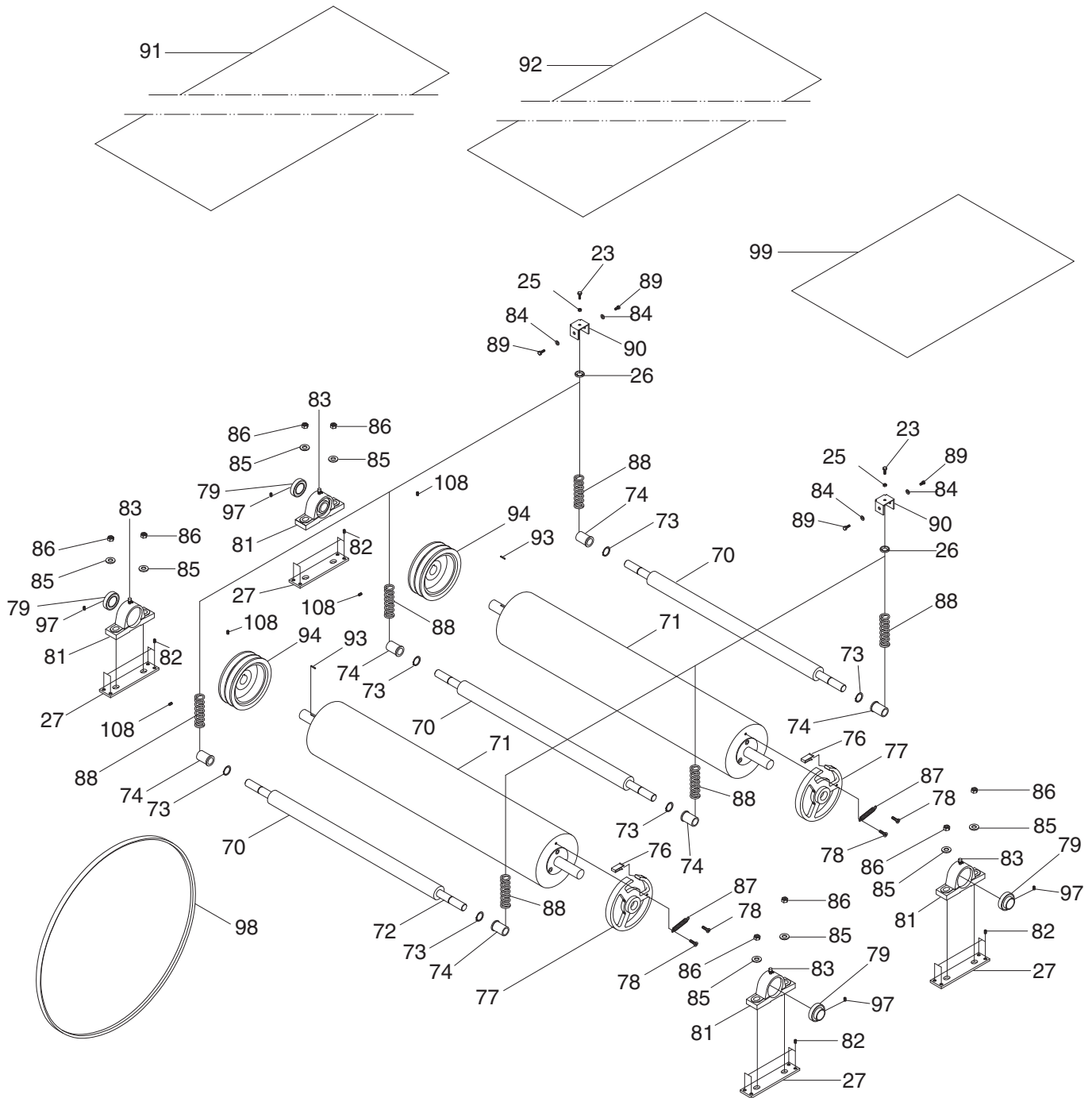

G1079R Parts List

REF	PART #	DESCRIPTION
1	P1079R001	FRAME
2	P1079R002	HEX NUT 3/8-16
3	P1079R003	FLAT WASHER 3/8
4	P1079R004	SIDE PANEL
5	P1079R005	BUSHING
6	P1079R006	SPROCKET
7	P1079R007	SPROCKET
7-1	P1079R007-1	SHAFT
8	P1079R008	TABLE SCREW 3/4-16
8-1	P1079R008-1	TABLE SCREW SHIM 1/2 X 27 X 1
8-2	P1079R008-2	TABLE SCREW SHIM 1/2 X 28 X 3
9	P1079R009	ELEVATION CHAIN
10	P1079R010	FRONT BRACE
11	P1079R011	SET SCREW 1/4-20 X 1/2
12	P1079R012	COMPLETE CRANK HANDLE ASSY
13	P1079R013	DUST PORT
14V2	P1079R014V2	HOOD V2.02.11
15V2	P1079R015V2	REAR BRACE V2.02.11
16V2	P1079R016V2	REAR PANEL V2.02.11
17	P1079R017	SET SCREW 5/16-18 X 1/2
18	P1079R018	MOTOR PULLEY
19	P1079R019	KEY 1/4 X 1/4 X 3
20	P1079R020	DRUM MOTOR 2HP, 220V, 1-PH
20-1	P1079R020-1	DRUM MOTOR FAN COVER
20-2	P1079R020-2	DRUM MOTOR FAN
20-3	P1079R020-3	S CAPACITOR 400M 125V 1-3/4 X 3-3/8
20-4	P1079R020-4	DRUM MOTOR JUNCTION BOX
20-5	P1079R020-5	CENTRIFUGAL SWITCH
21	P1079R021	HEX NUT 3/8-16
22	P1079R022	HEX BOLT 3/8-16 X 3/4
23	P1079R023	HEX BOLT 1/4-20 X 3/4
24	P1079R024	FLAT WASHER 3/8
25	P1079R025	HEX NUT 1/4-20
26	P1079R026	SPRING PLATE
27	P1079R027	ADJUST PLATE
29	P1079R029	TAP SCREW #6 X 1/2
31V2	P1079R031V2	POWER CORD 14G 3W 7' V2.02.09
32V2	P1079R032V2	FRONT PANEL V2.02.11
33V2	P1079R033V2	SINGLE PHASE ON/OFF SWITCH V2.02.11
34	P1079R034	HEX NUT 5/16-18
35	P1079R035	HEX NUT 3/4-16
36	P1079R036	TABLE FRAME
38	P1079R038	LOCK NUT 1/4-20
39	P1079R039	FEED MOTOR 1/4HP
39-1	P1079R039-1	R CAPACITOR 12M 350V 1-1/2 X 2
39-2	P1079R039-2	FEED MOTOR FAN COVER
39-3	P1079R039-3	FEED MOTOR FAN
39-4	P1079R039-4	FEED MOTOR JUNCTION BOX
40	P1079R040	FLAT WASHER 5/16
41	P1079R041	HEX NUT 5/16-18
42	P1079R042	KEY 5 X 5 X 20
43	P1079R043	DRIVE CHAIN
44	P1079R044	SPROCKET
45	P1079R045	SET SCREW 1/4-20 X 1/4
46	P1079R046	MOTOR BRACKET

REF	PART #	DESCRIPTION
47	P1079R047	CAP SCREW 1/4-20 X 3/4
48	P1079R048	FLAT WASHER 1/4
49	P1079R049	HEX BOLT 5/16-18 X 1
50	P1079R050	GUARD HINGED LEFT
51V2	P1079R051V2	ROLLER BRACKET V2.02.11
53	P1079R053	FLAT HD SCR 1/4-20 X 2-3/8
55	P1079R055	LATCH
56	P1079R056	LOCK WASHER 1/4
58	P1079R058	CAP SCREW 1/4-20 X 3/4
59	P1079R059	ROLLER GUARD
60	P1079R060	ROLLER AJUST BOLT 1/2-13 X 70
61	P1079R061	BUSHING SUPPORT
63	P1079R063	IDLER ROLLER
64	P1079R064	PLATE
65	P1079R065	DRIVE ROLLER
66	P1079R066	TABLE
67	P1079R067	SET SCREW 1/4-20 X 1/2
68	P1079R068	SPROCKET
69	P1079R069	RUBBER CONVEYOR BELT
70	P1079R070	PRESSURE ROLLER
71	P1079R071	SANDING DRUM
73	P1079R073	EXT RETAINING RING 19MM
74	P1079R074	BUSHING
76	P1079R076	CLIP
77	P1079R077	TENSION WHEEL
78	P1079R078	FLAT HD ALLEN SCR 1/4-20 X 1/2
79	P1079R079	PILLOW BLOCK BEARING UCP205
81	P1079R081	BEARING BLOCK
82	P1079R082	SET SCREW 5/16-24 X 1/2
83	P1079R083	GREASE FITTING M6-1 X 5
84	P1079R084	FLAT WASHER 1/4
85	P1079R085	FLAT WASHER 3/8
86	P1079R086	LOCK NUT 3/8-16
87	P1079R087	TENSION SPRING
88	P1079R088	COMPRESSION SPRING
89	P1079R089	HEX BOLT 1/4-20 X 3/8
90	P1079R090	BRACKET
91	P1079R091	SANDING ROLL 6" x 50' A60-X CLOTH
92	P1079R092	SANDING ROLL 6" x 50' A100-X CLOTH
93	P1079R093	KEY 6 X 6 X 30
94	P1079R094	SANDING DRUM PULLEY
97	P1079R097	SET SCREW 3/8-16 X 1/2
98	P1079R098	V-BELT B60
99	P1079R099	FELT 19 X 24 IN
100	P1079R100	SWITCH BOX
101	P1079R101	STRIKE
104	P1079R104	CONTROL WIRE 1015 16G 130MM
105	P1079R105	OVERLOAD BUTTON MB-15A
108	P1079R108	SET SCREW 1/4-20 X 1/2
116	P1079R116	DUST SCOOP DEFLECTOR
117V2	P1079R117V2	MOTOR CORD 16G 3W 30" V2.02.11
118V2	P1079R118V2	FEED MOTOR CORD V2.02.09
137	P1079R137	FLANGE BOLT 10-24 X 3/8
139	P1079R139	TAP SCREW #8 X 1/2
140	P1079R140	FLAT WASHER #10
149	P1079R149	HEX WRENCH 3MM



G1079R Parts List (Cont.)

REF	PART #	DESCRIPTION
150	P1079R150	HINGE
151	P1079R151	HANDLE
152	P1079R152	LEFT SUPPORT ARM
153	P1079R153	RIGHT SUPPORT ARM
154	P1079R154	CAP SCREW 5/16-18 X 5/8
155	P1079R155	HEX NUT 5/16-18
156	P1079R156	PHLP HD SCR 2-32 X 1/2
157	P1079R157	HEX NUT 2-32
158	P1079R158	FRONT CHAIN COVER
159	P1079R159	REAR CHAIN COVER
160	P1079R160	PHLP HD SCR 10-24 X 3/8
161	P1079R161	FLAT WASHER #10
162	P1079R162	HEX NUT 10-24
163	P1079R163	PLATE
164	P1079R164	LEFT REAR ROLLER GUARD
165	P1079R165	PHLP HD SCR 10-24 X 1/2
166	P1079R166	HEX NUT 10-24
167	P1079R167	EXT TOOTH WASHER #10

REF	PART #	DESCRIPTION
168	P1079R168	STRAIN RELIEF SB6R-3
174	P1079R174	STRAIN RELIEF MGB16-10B
175	P1079R175	PADLOCK STORAGE HOOK
176	P1079R176	SWITCH PADLOCK
177	P1079R177	TAP SCREW #8 X 1/2
178	P1079R178	TAP SCREW #8 X 3/8
179	P1079R179	PHLP HD SCR 5-32 X 1/4
180	P1079R180	DEPTH SCALE
181	P1079R181	SCALE POINTER
182	P1079R182	FLAT WASHER 1/4
183	P1079R183	PHLP HD SCR 1/4-20 X 3/8
200	P1079R200	MACHINE ID/WARNING LABEL
203	P1079R203	SAFETY GLASSES LABEL 2W X 3.3H
204	P1079R204	READ MANUAL LABEL 2W X 3.3H
205	P1079R205	DISCONNECT SANDER LABEL 220V
206	P1079R206	ELECTRICITY LABEL 1.4W X 1.2H
208	P1079R208	FEED ONLY ONE LABEL V1.07.02
209	P1079R209	GRIZZLY NAMEPLATE- SMALL





WARRANTY CARD

Name _____
 Street _____
 City _____ State _____ Zip _____
 Phone # _____ Email _____
 Model # _____ Order # _____ Serial # _____

The following information is given on a voluntary basis. It will be used for marketing purposes to help us develop better products and services. **Of course, all information is strictly confidential.**

- How did you learn about us?

<input type="checkbox"/> Advertisement	<input type="checkbox"/> Friend	<input type="checkbox"/> Catalog
<input type="checkbox"/> Card Deck	<input type="checkbox"/> Website	<input type="checkbox"/> Other:
- Which of the following magazines do you subscribe to?

<input type="checkbox"/> Cabinetmaker & FDM	<input type="checkbox"/> Popular Science	<input type="checkbox"/> Wooden Boat
<input type="checkbox"/> Family Handyman	<input type="checkbox"/> Popular Woodworking	<input type="checkbox"/> Woodshop News
<input type="checkbox"/> Hand Loader	<input type="checkbox"/> Precision Shooter	<input type="checkbox"/> Woodsmith
<input type="checkbox"/> Handy	<input type="checkbox"/> Projects in Metal	<input type="checkbox"/> Woodwork
<input type="checkbox"/> Home Shop Machinist	<input type="checkbox"/> RC Modeler	<input type="checkbox"/> Woodworker West
<input type="checkbox"/> Journal of Light Cont.	<input type="checkbox"/> Rifle	<input type="checkbox"/> Woodworker's Journal
<input type="checkbox"/> Live Steam	<input type="checkbox"/> Shop Notes	<input type="checkbox"/> Other:
<input type="checkbox"/> Model Airplane News	<input type="checkbox"/> Shotgun News	
<input type="checkbox"/> Old House Journal	<input type="checkbox"/> Today's Homeowner	
<input type="checkbox"/> Popular Mechanics	<input type="checkbox"/> Wood	
- What is your annual household income?

<input type="checkbox"/> \$20,000-\$29,000	<input type="checkbox"/> \$30,000-\$39,000	<input type="checkbox"/> \$40,000-\$49,000
<input type="checkbox"/> \$50,000-\$59,000	<input type="checkbox"/> \$60,000-\$69,000	<input type="checkbox"/> \$70,000+
- What is your age group?

<input type="checkbox"/> 20-29	<input type="checkbox"/> 30-39	<input type="checkbox"/> 40-49
<input type="checkbox"/> 50-59	<input type="checkbox"/> 60-69	<input type="checkbox"/> 70+
- How long have you been a woodworker/metalworker?

<input type="checkbox"/> 0-2 Years	<input type="checkbox"/> 2-8 Years	<input type="checkbox"/> 8-20 Years	<input type="checkbox"/> 20+ Years
------------------------------------	------------------------------------	-------------------------------------	------------------------------------
- How many of your machines or tools are Grizzly?

<input type="checkbox"/> 0-2	<input type="checkbox"/> 3-5	<input type="checkbox"/> 6-9	<input type="checkbox"/> 10+
------------------------------	------------------------------	------------------------------	------------------------------
- Do you think your machine represents a good value? Yes No
- Would you recommend Grizzly Industrial to a friend? Yes No
- Would you allow us to use your name as a reference for Grizzly customers in your area?
Note: We never use names more than 3 times. Yes No

10. Comments: _____

CUT ALONG DOTTED LINE

FOLD ALONG DOTTED LINE



Place
Stamp
Here



GRIZZLY INDUSTRIAL, INC.
P.O. BOX 2069
BELLINGHAM, WA 98227-2069



FOLD ALONG DOTTED LINE

Send a Grizzly Catalog to a friend:

Name _____
Street _____
City _____ State _____ Zip _____

TAPE ALONG EDGES--PLEASE DO NOT STAPLE

WARRANTY & RETURNS

Grizzly Industrial, Inc. warrants every product it sells for a period of **1 year** to the original purchaser from the date of purchase. This warranty does not apply to defects due directly or indirectly to misuse, abuse, negligence, accidents, repairs or alterations or lack of maintenance. This is Grizzly's sole written warranty and any and all warranties that may be implied by law, including any merchantability or fitness, for any particular purpose, are hereby limited to the duration of this written warranty. We do not warrant or represent that the merchandise complies with the provisions of any law or acts unless the manufacturer so warrants. In no event shall Grizzly's liability under this warranty exceed the purchase price paid for the product and any legal actions brought against Grizzly shall be tried in the State of Washington, County of Whatcom.

We shall in no event be liable for death, injuries to persons or property or for incidental, contingent, special, or consequential damages arising from the use of our products.

To take advantage of this warranty, contact us by mail or phone and give us all the details. We will then issue you a "Return Number," which must be clearly posted on the outside as well as the inside of the carton. We will not accept any item back without this number. Proof of purchase must accompany the merchandise.

The manufacturers reserve the right to change specifications at any time because they constantly strive to achieve better quality equipment. We make every effort to ensure that our products meet high quality and durability standards and we hope you never need to use this warranty.

Please feel free to write or call us if you have any questions about the machine or the manual.

Thank you again for your business and continued support. We hope to serve you again soon.

grizzly.com[®]

TOOL WEBSITE

Buy Direct and Save with Grizzly[®] – Trusted, Proven and a Great Value!
~Since 1983~

*Visit Our Website Today For
Current Specials!*

**ORDER
24 HOURS A DAY!
1-800-523-4777**

