

Grizzly *Industrial, Inc.*®

MODEL G1026 3 HP HEAVY-DUTY SHAPER OWNER'S MANUAL *(For models manufactured since 10/13)*



COPYRIGHT ©1991 BY GRIZZLY INDUSTRIAL, INC. REVISED FEBRUARY, 2021 (BL)
**WARNING: NO PORTION OF THIS MANUAL MAY BE REPRODUCED IN ANY SHAPE
OR FORM WITHOUT THE WRITTEN APPROVAL OF GRIZZLY INDUSTRIAL, INC.**
#BL3325 PRINTED IN TAIWAN

V3.02.21



WARNING!

This manual provides critical safety instructions on the proper setup, operation, maintenance, and service of this machine/tool. Save this document, refer to it often, and use it to instruct other operators.

Failure to read, understand and follow the instructions in this manual may result in fire or serious personal injury—including amputation, electrocution, or death.

The owner of this machine/tool is solely responsible for its safe use. This responsibility includes but is not limited to proper installation in a safe environment, personnel training and usage authorization, proper inspection and maintenance, manual availability and comprehension, application of safety devices, cutting/sanding/grinding tool integrity, and the usage of personal protective equipment.

The manufacturer will not be held liable for injury or property damage from negligence, improper training, machine modifications or misuse.



WARNING!

Some dust created by power sanding, sawing, grinding, drilling, and other construction activities contains chemicals known to the State of California to cause cancer, birth defects or other reproductive harm. Some examples of these chemicals are:

- **Lead from lead-based paints.**
- **Crystalline silica from bricks, cement and other masonry products.**
- **Arsenic and chromium from chemically-treated lumber.**

Your risk from these exposures varies, depending on how often you do this type of work. To reduce your exposure to these chemicals: Work in a well ventilated area, and work with approved safety equipment, such as those dust masks that are specially designed to filter out microscopic particles.

Table of Contents

INTRODUCTION	2	Safety Guard Adjustment.....	31
Contact Info	2	Straight Shaping	32
Manual Accuracy	2	Shaping Small Stock.....	34
Identification.....	3	Rub Collars	34
Controls & Components.....	4	Irregular Shaping	35
Machine Data Sheet	5	Pattern Work.....	37
SECTION 1: SAFETY	7	SECTION 5: ACCESSORIES	38
Safety Instructions for Machinery	7	SECTION 6: MAINTENANCE	41
Additional Safety for Shapers	9	Schedule.....	41
SECTION 2: POWER SUPPLY	10	Cleaning & Protecting	41
SECTION 3: SETUP	12	Lubrication	42
Needed for Setup.....	12	Spindle Bearings.....	42
Unpacking	12	V-Belt Tension & Replacement	43
Hardware Recognition Chart	13	SECTION 7: SERVICE	44
Inventory	14	Troubleshooting	44
Cleanup.....	15	Table Insert Adjustment	46
Site Considerations.....	16	Fence Board Alignment	47
Assembly	17	Truing Fence.....	47
Spindle.....	19	Pulley Alignment	48
Table Inserts	20	Gib Adjustment	49
Extension Wing.....	21	SECTION 8: WIRING	51
Fence Assembly	22	Wiring Safety Instructions	51
Safety Guard.....	23	Wiring Diagram	52
Hold-Downs	24	SECTION 9: PARTS	53
Dust Collection.....	25	Stand & Table	53
Test Run.....	26	Motor & Handwheel	55
SECTION 4: OPERATIONS	27	Spindle	57
Operation Overview	27	Safety Guard.....	59
Disabling & Locking Switch	28	Fence	60
Workpiece Inspection.....	28	Miter Gauge	61
Changing Cutter Rotation	29	Labels & Cosmetics	62
Speed Changes	29	WARRANTY & RETURNS	65
Cutter Installation.....	30		
Spindle Height	30		
Fence Adjustment.....	31		

INTRODUCTION

Contact Info

We stand behind our machines! If you have questions or need help, contact us with the information below. Before contacting, make sure you get the **serial number** and **manufacture date** from the machine ID label. This will help us help you faster.

Grizzly Technical Support
1815 W. Battlefield
Springfield, MO 65807
Phone: (570) 546-9663
Email: techsupport@grizzly.com

We want your feedback on this manual. What did you like about it? Where could it be improved? Please take a few minutes to give us feedback.

Grizzly Documentation Manager
P.O. Box 2069
Bellingham, WA 98227-2069
Email: manuals@grizzly.com

Manual Accuracy

We are proud to provide a high-quality owner's manual with your new machine!

We made every effort to be exact with the instructions, specifications, drawings, and photographs in this manual. Sometimes we make mistakes, but our policy of continuous improvement also means that **sometimes the machine you receive is slightly different than shown in the manual.**

If you find this to be the case, and the difference between the manual and machine leaves you confused or unsure about something, check our website for an updated version. We post current manuals and manual updates for free on our website at **www.grizzly.com**.

Alternatively, you can call our Technical Support for help. Before calling, make sure you write down the **Manufacture Date** and **Serial Number** from the machine ID label (see below). This information is required for us to provide proper tech support, and it helps us determine if updated documentation is available for your machine.

		MODEL GXXXX MACHINE NAME	
SPECIFICATIONS		▲ WARNING!	
Motor:	To reduce risk of serious injury when using this machine:		
Specification:	Read manual before operation.		
Specification:	Wear safety glasses and respirator.		
Specification:	Ensure safety is correctly adjusted/setup and		
Specification:	power is connected to grounded circuit before starting.		
Weight:	4. Make sure the motor has stopped and disconnect		
	power before adjustments, maintenance, or service.		
	5. DO NOT expose to rain or dampness.		
	6. DO NOT modify this machine in any way.		
	7.		
	8.		
	9. Do not use while under the influence of drugs or alcohol.		
	10. Maintain machine carefully to prevent accidents.		
Manufactured for Grizzly in Taiwan			

Manufacture Date

Serial Number



Identification

Become familiar with the names and locations of the controls and features shown below to better understand the instructions in this manual.

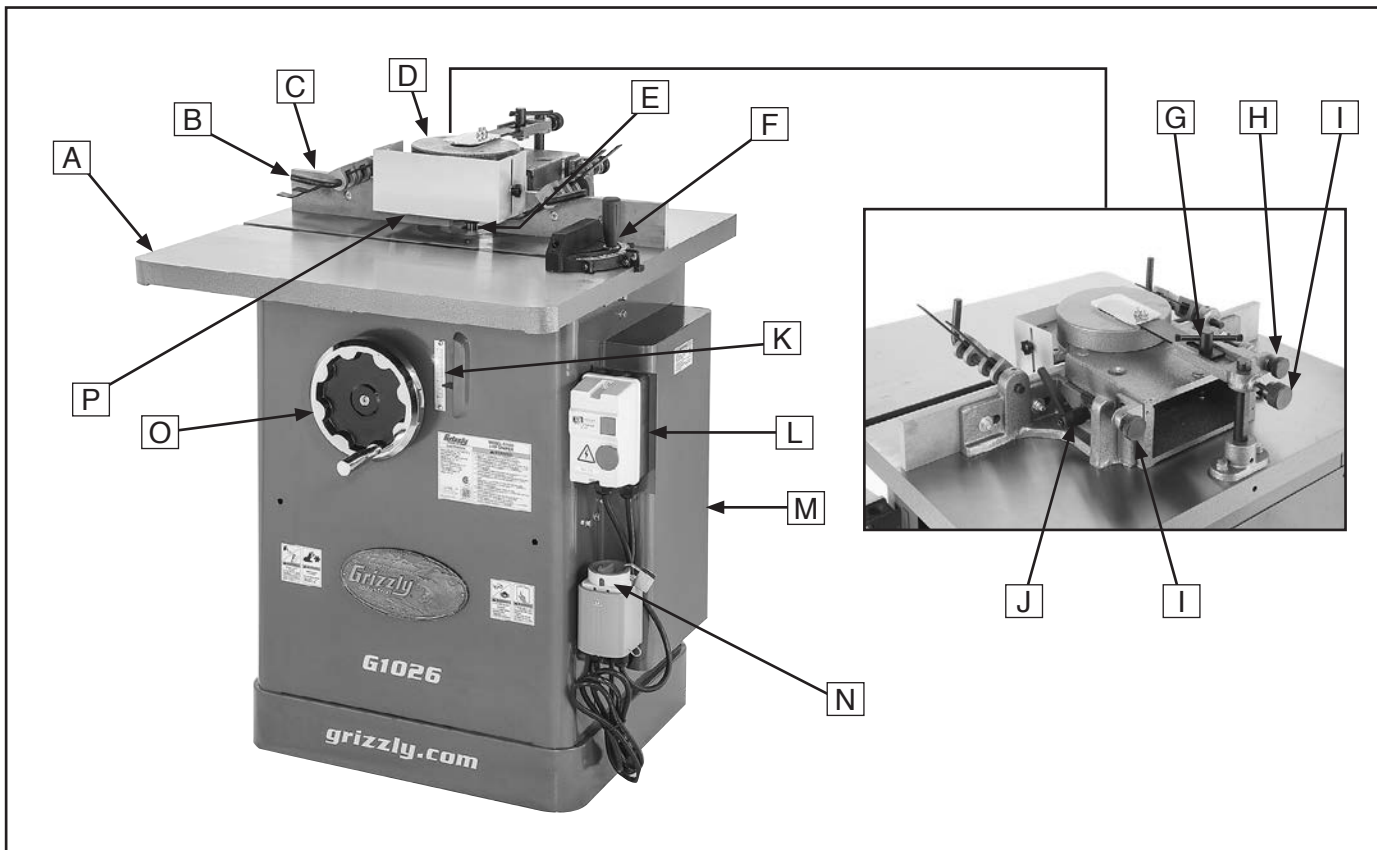

- | | |
|---------------------------|-------------------------------------|
| A. Work Table | I. Guard Lock Knob |
| B. Hold Down | J. Fence Lock Handle (1 of 2) |
| C. Fence (1 of 2) | K. Spindle Height Scale |
| D. Cutterhead Guard | L. Magnetic Switch |
| E. Spindle Assembly | M. Motor Cover |
| F. Miter Gauge | N. Forward/Reverse (FOR/REV) Switch |
| G. Guard Lock Handle | O. Spindle Elevation Handwheel |
| H. Fence Adjustment Knobs | P. Safety Guard |

!WARNING

For Your Own Safety Read Instruction Manual Before Operating Shaper

- a) Wear eye protection.
- b) Always keep cutterhead guard in place and in proper operating condition.
- c) Be sure keyed washer is directly under spindle nut and spindle nut is tight
- d) Feed workpiece **AGAINST** rotation of cutter.
- e) Keep fingers away from revolving cutter—use fixtures when necessary.
- f) Do not use awkward hand positions.



Controls & Components



Refer to the following figures and descriptions to become familiar with the basic controls and components of this machine. Understanding these items and how they work will help you understand the rest of the manual and minimize your risk of injury when operating this machine.

Work Area Controls

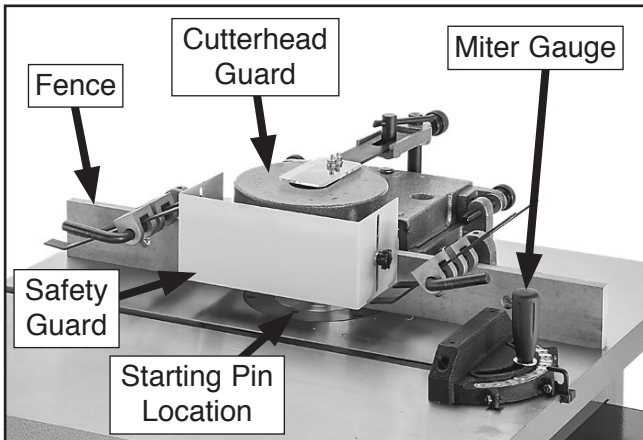

Figure 2. Work area components.

Fence: Each fence is independently adjustable side-to-side and front to back. Also removable for easy replacement with a zero-clearance or other custom-made fence.

Cutterhead and Safety Guards: Adjust to protect user from chips thrown by cutterhead.

Miter Gauge: Supports workpiece for controlled straight or angled cuts as it slides along the work table miter slot.

Starting Pin (not shown): Supports workpiece during beginning of freehand cuts until workpiece contacts rub collar (refer to **Page 35**).

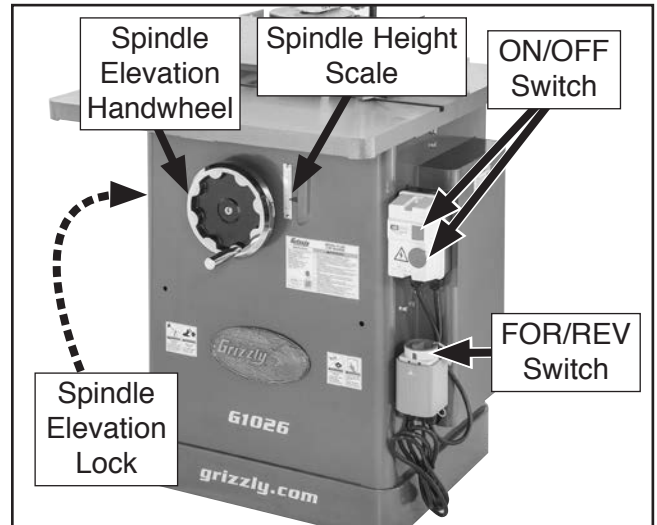

Figure 3. Work area components.

Spindle Elevation Handwheel: Raises and lowers spindle and cutter to desired height.

Spindle Height Scale: Displays the height position of the spindle in inches.

ON/OFF Switch: Turns machine ON and OFF.

Forward/Reverse (FOR/REV) Switch: Starts, stops, and reverses spindle rotation.

Spindle Elevation Lock (not shown): Locks spindle and bit height adjustments.

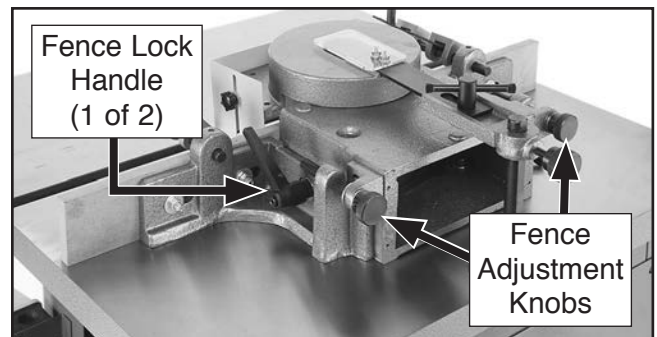

Figure 4. Fence controls.

Fence Lock Handles: Tighten to lock fence position on table.

Fence Adjustment Knobs: Move each fence independently relative to cutterhead. One turn moves each fence approximately $\frac{5}{64}$ " (.078").





MACHINE DATA SHEET

Customer Service #: (570) 546-9663 · To Order Call: (800) 523-4777 · Fax #: (800) 438-5901

MODEL G1026 3 HP SHAPER

Product Dimensions:

Weight..... 345 lbs.
 Width (side-to-side) x Depth (front-to-back) x Height..... 30 x 30-1/2 x 39-1/2 in.
 Footprint (Length x Width)..... 21 x 23-1/2 in.

Shipping Dimensions:

Type..... Cardboard Box
 Content..... Machine
 Weight..... 392 lbs.
 Length x Width x Height..... 31 x 26 x 42 in.
 Must Ship Upright..... Yes

Electrical:

Power Requirement..... 240V, Single-Phase, 60 Hz
 Prewired Voltage..... 240V
 Full-Load Current Rating..... 12A
 Minimum Circuit Size..... 15A
 Connection Type..... Cord & Plug
 Power Cord Included..... Yes
 Power Cord Length..... 6 ft.
 Power Cord Gauge..... 14 AWG
 Plug Included..... Yes
 Included Plug Type..... 6-15
 Switch Type..... Magnetic Switch w/Overload Protection

Motors:

Main

Horsepower..... 3 HP
 Phase..... Single-Phase
 Amps..... 12A
 Speed..... 3450 RPM
 Type..... TEFC Capacitor-Start Induction
 Power Transfer..... Belt Drive
 Bearings..... Shielded & Permanently Lubricated
 Centrifugal Switch/Contacts Type..... External

Main Specifications:

Operation Info

Max. Cutter Height..... 2-1/2 in.
 Max. Cutter Diameter..... 5-1/2 in.
 Spindle Sizes..... 1/2, 3/4, 1 in.
 Spindle Lengths..... 2-3/4, 3-1/2, 3 in.
 Exposed Spindle Length..... 3-1/8 in.
 Spindle Cap. Under the Nut..... 2, 2-1/2, 2-1/4 in.
 Spindle Speeds..... 7,000, 10,000 RPM
 Spindle Travel..... 3 in.
 Spindle Openings..... 1-1/2, 3, 4, 7 in.



Table Info

Number of Table Inserts.....	3
Table Insert Sizes I.D.....	1-1/2, 3, 4-1/4 in.
Table Insert Sizes O.D.....	3, 4-1/4, 7 in.
Table Counterbore Diameter.....	7 in.
Table Counterbore Depth.....	5/8 in.
Table Size Length.....	28-1/4 in.
Table Size With Ext. Wing Length.....	28-1/4 in.
Table Size Width.....	21-3/4 in.
Table Size With Ext Wing Width.....	30-1/2 in.
Table Size Thickness.....	1-1/2 in.
Table Size With Ext. Wing Thickness.....	1-1/2 in.
Floor to Table Height.....	34 in.
Table Fence Length.....	26-15/16 in.
Table Fence Width.....	5/8 in.
Table Fence Height.....	2-3/4 in.

Miter Gauge Info

Miter Angle.....	0 – 60 deg. L/R
Miter Gauge Slot Type.....	Straight Slot
Miter Gauge Slot Width.....	3/4 in.
Miter Gauge Slot Height.....	3/8 in.

Construction

Table.....	Precision-Ground Cast Iron
Body Assembly.....	Cast Iron
Cabinet.....	Formed Steel
Fence.....	Cast Iron with Wood
Miter Gauge.....	Cast Iron
Guard.....	Cast Iron
Spindle Bearings.....	Sealed & Lubricated
Paint Type/Finish.....	Powder Coated

Other

Number of Dust Ports.....	1
Dust Port Size.....	3 in.
Mobile Base.....	D2057A

Other Specifications:

Country of Origin	Taiwan
Warranty	1 Year
Approximate Assembly & Setup Time	30 Minutes
Serial Number Location	ID Label on Center of Stand
ISO 9001 Factory	No
Certified by a Nationally Recognized Testing Laboratory (NRTL)	Yes

Features:

- Cast-Iron Miter Gauge & Starting Pins
- Precision-Ground Cast-Iron Table
- Green Powder Coated Paint
- Smooth Fence Adjustment
- Interchangeable Spindles-1/2", 3/4", and 1"
- Two Speed Spindles
- Vertical Spindle Lock
- Hold Downs
- Reversing Switch
- Spindle Lock
- Magnetic Switch with Thermal Overload Protector
- Guard



SECTION 1: SAFETY

For Your Own Safety, Read Instruction Manual Before Operating This Machine

The purpose of safety symbols is to attract your attention to possible hazardous conditions. This manual uses a series of symbols and signal words intended to convey the level of importance of the safety messages. The progression of symbols is described below. Remember that safety messages by themselves do not eliminate danger and are not a substitute for proper accident prevention measures. Always use common sense and good judgment.



Indicates an imminently hazardous situation which, if not avoided, **WILL** result in death or serious injury.



Indicates a potentially hazardous situation which, if not avoided, **COULD** result in death or serious injury.



Indicates a potentially hazardous situation which, if not avoided, **MAY** result in minor or moderate injury. It may also be used to alert against unsafe practices.

NOTICE

Alerts the user to useful information about proper operation of the machine to avoid machine damage.

Safety Instructions for Machinery

WARNING

OWNER'S MANUAL. Read and understand this owner's manual **BEFORE** using machine.

TRAINED OPERATORS ONLY. Untrained operators have a higher risk of being hurt or killed. Only allow trained/supervised people to use this machine. When machine is not being used, disconnect power, remove switch keys, or lock-out machine to prevent unauthorized use—especially around children. Make your workshop kid proof!

DANGEROUS ENVIRONMENTS. Do not use machinery in areas that are wet, cluttered, or have poor lighting. Operating machinery in these areas greatly increases the risk of accidents and injury.

MENTAL ALERTNESS REQUIRED. Full mental alertness is required for safe operation of machinery. Never operate under the influence of drugs or alcohol, when tired, or when distracted.

ELECTRICAL EQUIPMENT INJURY RISKS. You can be shocked, burned, or killed by touching live electrical components or improperly grounded machinery. To reduce this risk, only allow qualified service personnel to do electrical installation or repair work, and always disconnect power before accessing or exposing electrical equipment.

DISCONNECT POWER FIRST. Always disconnect machine from power supply **BEFORE** making adjustments, changing tooling, or servicing machine. This prevents an injury risk from unintended startup or contact with live electrical components.

EYE PROTECTION. Always wear ANSI-approved safety glasses or a face shield when operating or observing machinery to reduce the risk of eye injury or blindness from flying particles. Everyday eyeglasses are **NOT** approved safety glasses.



WARNING

WEARING PROPER APPAREL. Do not wear clothing, apparel or jewelry that can become entangled in moving parts. Always tie back or cover long hair. Wear non-slip footwear to reduce risk of slipping and losing control or accidentally contacting cutting tool or moving parts.

HAZARDOUS DUST. Dust created by machinery operations may cause cancer, birth defects, or long-term respiratory damage. Be aware of dust hazards associated with each workpiece material. Always wear a NIOSH-approved respirator to reduce your risk.

HEARING PROTECTION. Always wear hearing protection when operating or observing loud machinery. Extended exposure to this noise without hearing protection can cause permanent hearing loss.

REMOVE ADJUSTING TOOLS. Tools left on machinery can become dangerous projectiles upon startup. Never leave chuck keys, wrenches, or any other tools on machine. Always verify removal before starting!

USE CORRECT TOOL FOR THE JOB. Only use this tool for its intended purpose—do not force it or an attachment to do a job for which it was not designed. Never make unapproved modifications—modifying tool or using it differently than intended may result in malfunction or mechanical failure that can lead to personal injury or death!

AWKWARD POSITIONS. Keep proper footing and balance at all times when operating machine. Do not overreach! Avoid awkward hand positions that make workpiece control difficult or increase the risk of accidental injury.

CHILDREN & BYSTANDERS. Keep children and bystanders at a safe distance from the work area. Stop using machine if they become a distraction.

GUARDS & COVERS. Guards and covers reduce accidental contact with moving parts or flying debris. Make sure they are properly installed, undamaged, and working correctly **BEFORE** operating machine.

FORCING MACHINERY. Do not force machine. It will do the job safer and better at the rate for which it was designed.

NEVER STAND ON MACHINE. Serious injury may occur if machine is tipped or if the cutting tool is unintentionally contacted.

STABLE MACHINE. Unexpected movement during operation greatly increases risk of injury or loss of control. Before starting, verify machine is stable and mobile base (if used) is locked.

USE RECOMMENDED ACCESSORIES. Consult this owner's manual or the manufacturer for recommended accessories. Using improper accessories will increase the risk of serious injury.

UNATTENDED OPERATION. To reduce the risk of accidental injury, turn machine **OFF** and ensure all moving parts completely stop before walking away. Never leave machine running while unattended.

MAINTAIN WITH CARE. Follow all maintenance instructions and lubrication schedules to keep machine in good working condition. A machine that is improperly maintained could malfunction, leading to serious personal injury or death.

DAMAGED PARTS. Regularly inspect machine for damaged, loose, or mis-adjusted parts—or any condition that could affect safe operation. Immediately repair/replace **BEFORE** operating machine. For your own safety, **DO NOT** operate machine with damaged parts!

MAINTAIN POWER CORDS. When disconnecting cord-connected machines from power, grab and pull the plug—**NOT** the cord. Pulling the cord may damage the wires inside. Do not handle cord/plug with wet hands. Avoid cord damage by keeping it away from heated surfaces, high traffic areas, harsh chemicals, and wet/damp locations.

EXPERIENCING DIFFICULTIES. If at any time you experience difficulties performing the intended operation, stop using the machine! Contact our Technical Support at (570) 546-9663.



Additional Safety for Shapers

WARNING

Serious cuts, amputation, entanglement, or death can occur from contact with rotating cutter. Cutters or other parts improperly secured to spindle can fly off and strike nearby operators with great force. Flying debris can cause eye injuries or blindness. To minimize risk of getting hurt or killed, anyone operating shaper MUST completely heed hazards and warnings below.

AVOIDING CUTTER CONTACT: Keep unused portion of cutter below table. Use smallest table insert possible. Adjust fences and guards as close as practical to cutter, or use a zero-clearance fence or box guard. *Always keep some type of guard or other protective device between your hands and cutter at all times!*

PROTECT HANDS/FINGERS: While feeding workpiece, avoid awkward hand positions. Never pass hands directly over, or in front of, cutter. As one hand approaches a 6-inch radius point from cutter, move it in an arc motion away from cutter, and reposition it on the outfeed side.

FEEDING WORKPIECE: To reduce risk of accidental cutterhead contact, always use push blocks or some type of fixture, jig, or hold-down device to safely feed workpiece while cutting. Use an outfeed support table if shaping long workpieces to ensure proper support throughout entire cutting procedure. ALWAYS feed workpiece AGAINST rotation of cutter. NEVER start shaper with workpiece contacting cutter!

CUTTING DEPTH: Never attempt to remove too much material in one pass. Doing this increases risk of workpiece kickback. Instead, make several light passes—this is a safer way to cut and it leaves a cleaner finish.

WORKPIECE CONDITION: Shaping a workpiece with knots, holes, or foreign objects increases risk of kickback and cutter damage/breakage. Thoroughly inspect and prepare workpiece before shaping. Always “square up” a workpiece before shaping or flatten workpiece edges with a jointer or planer. Rough, warped, or wet workpieces increase risk of kickback.

CUTTER POSITIONING: Whenever possible, make shaping cuts with cutter on *underside* of workpiece to reduce operator exposure to cutter.

SMALL WORKPIECES: There is a high risk of accidental cutter contact with small workpieces, because they are closer to cutter and more difficult to control. To reduce your risk, only feed small workpieces using jigs or holding fixtures that allow your hands to stay safely away from cutter. When possible, shape longer stock and cut to size.

SAFE CUTTER CLEARANCES: Operator or bystanders may be hit by flying debris if cutter contacts fence, guard, or table insert upon startup. Always ensure any new cutter setup has proper cutter rotational clearance before startup.

SAFE CUTTER INSTALLATION: Improperly secured knives/inserts, cutters, or rub collars may become dangerous projectiles if they come loose. Always ensure keyed washer is directly under spindle nut and spindle nut is tight. If spindle does not use a keyed washer, always use two spindle nuts together, and ensure BOTH are tight. Never use cutters/bits rated for an RPM lower than spindle speed.

AVOIDING CLIMB CUTS: Feeding workpiece in same direction of cutter rotation is a “climb cut.” Climb cutting can aggressively pull workpiece—and hands—into cutter. Always first verify direction of cutter rotation before starting, and always feed workpiece AGAINST cutter rotation.

SAFETY GUARDS. To reduce risk of unintentional contact with cutter, always ensure included cutter guard, or a properly dimensioned box guard, or some other type of guard is installed and correctly positioned before operation.

CONTOUR SHAPING: To reduce risk of unintentional cutter contact while freehand shaping or using a rub collar as a guide, always use an overhead or “ring” type guard. To reduce kickback risk, always use starting pin or pivot board when starting the cut. NEVER start shaping at a corner!



SECTION 2: POWER SUPPLY

Availability

Before installing the machine, consider the availability and proximity of the required power supply circuit. If an existing circuit does not meet the requirements for this machine, a new circuit must be installed. To minimize the risk of electrocution, fire, or equipment damage, installation work and electrical wiring must be done by an electrician or qualified service personnel in accordance with all applicable codes and standards.

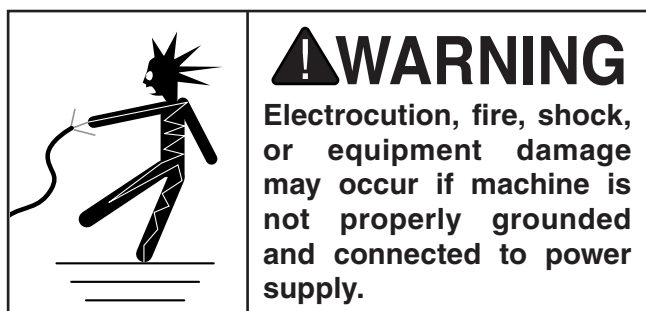

Full-Load Current Rating

The full-load current rating is the amperage a machine draws at 100% of the rated output power. On machines with multiple motors, this is the amperage drawn by the largest motor or sum of all motors and electrical devices that might operate at one time during normal operations.

Full-Load Current Rating at 220V 12 Amps

The full-load current is not the maximum amount of amps that the machine will draw. If the machine is overloaded, it will draw additional amps beyond the full-load rating.

If the machine is overloaded for a sufficient length of time, damage, overheating, or fire may result—especially if connected to an undersized circuit. To reduce the risk of these hazards, avoid overloading the machine during operation and make sure it is connected to a power supply circuit that meets the specified circuit requirements.

Circuit Information

A power supply circuit includes all electrical equipment between the breaker box or fuse panel in the building and the machine. The power supply circuit used for this machine must be sized to safely handle the full-load current drawn from the machine for an extended period of time. (If this machine is connected to a circuit protected by fuses, use a time delay fuse marked D.)

! CAUTION
For your own safety and protection of property, consult an electrician if you are unsure about wiring practices or electrical codes in your area.

Note: *Circuit requirements in this manual apply to a dedicated circuit—where only one machine will be running on the circuit at a time. If machine will be connected to a shared circuit where multiple machines may be running at the same time, consult an electrician or qualified service personnel to ensure circuit is properly sized for safe operation.*

Circuit Requirements

This machine is prewired to operate on a power supply circuit that has a verified ground and meets the following requirements:

Nominal Voltage 208V, 220V, 230V, 240V
Cycle 60 Hz
Phase Single-Phase
Power Supply Circuit 15 Amps
Plug/Receptacle NEMA 6-15



Grounding Requirements

This machine **MUST** be grounded. In the event of certain malfunctions or breakdowns, grounding reduces the risk of electric shock by providing a path of least resistance for electric current.

This machine is equipped with a power cord that has an equipment-grounding wire and a grounding plug. Only insert plug into a matching receptacle (outlet) that is properly installed and grounded in accordance with all local codes and ordinances. **DO NOT** modify the provided plug!

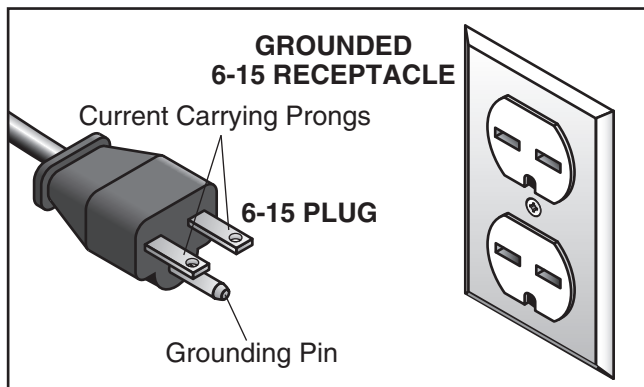
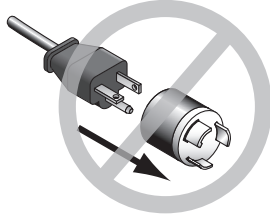

Figure 5. Typical 6-15 plug and receptacle.

CAUTION



No adapter should be used with plug. If plug does not fit available receptacle, or if machine must be reconnected for use on a different type of circuit, reconnection must be performed by an electrician or qualified service personnel, and it must comply with all local codes and ordinances.

WARNING

Serious injury could occur if you connect machine to power before completing setup process. DO NOT connect to power until instructed later in this manual.

Improper connection of the equipment-grounding wire can result in a risk of electric shock. The wire with green insulation (with or without yellow stripes) is the equipment-grounding wire. If repair or replacement of the power cord or plug is necessary, do not connect the equipment-grounding wire to a live (current carrying) terminal.

Check with a qualified electrician or service personnel if you do not understand these grounding requirements, or if you are in doubt about whether the tool is properly grounded. If you ever notice that a cord or plug is damaged or worn, disconnect it from power, and immediately replace it with a new one.

Extension Cords

We do not recommend using an extension cord with this machine. If you must use an extension cord, only use it if absolutely necessary and only on a temporary basis.

Extension cords cause voltage drop, which can damage electrical components and shorten motor life. Voltage drop increases as the extension cord size gets longer and the gauge size gets smaller (higher gauge numbers indicate smaller sizes).

Any extension cord used with this machine must be in good condition and contain a ground wire and matching plug/receptacle. Additionally, it must meet the following size requirements:

Minimum Gauge Size 14 AWG
Maximum Length (Shorter is Better).....50 ft.



SECTION 3: SETUP

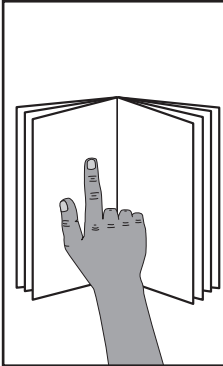

!WARNING

This machine presents serious injury hazards to untrained users. Read through this entire manual to become familiar with the controls and operations before starting the machine!

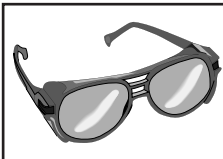

!WARNING

Wear safety glasses during the entire setup process!



!WARNING

HEAVY LIFT!

Straining or crushing injury may occur from improperly lifting machine or some of its parts. To reduce this risk, get help from other people and use a forklift (or other lifting equipment) rated for weight of this machine.

Needed for Setup

The following items are needed, but not included, for the setup/assembly of this machine.

Description	Qty
• Another Person	1
• Safety Glasses (for each person).....	1
• Cleaner/Degreaser (Page 15)	As Needed
• Precision Level	1
• Disposable Shop Rags.....	As Needed
• Straightedge 12" or Longer	1
• Dust Collection System	1
• Dust Hose 3"	1
• Hose Clamps 3"	2
• Open-End Wrench 12, 14, 17mm	1 Ea.
• Hex Wrench 4, 8mm.....	1 Ea.
• Screwdriver Phillips #2	1
• Screwdriver Flat Head #2.....	1

Unpacking

This machine was carefully packaged for safe transport. When unpacking, separate all enclosed items from packaging materials and inspect them for shipping damage. ***If items are damaged, please call us immediately at (570) 546-9663.***

IMPORTANT: Save all packaging materials until you are completely satisfied with the machine and have resolved any issues between Grizzly or the shipping agent. ***You MUST have the original packaging to file a freight claim. It is also extremely helpful if you need to return your machine later.***



Hardware Recognition Chart

USE THIS CHART TO MATCH UP
HARDWARE DURING THE INVENTORY
AND ASSEMBLY PROCESS.

MEASURE BOLT DIAMETER BY PLACING INSIDE CIRCLE

#10

1/4"

5/16"

3/8"

7/16"

1/2"

4mm

5mm

6mm

8mm

10mm

12mm

16mm



Hex
Wrench

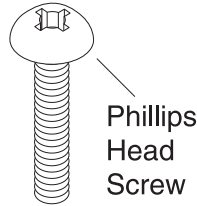

Phillips
Head
Screw

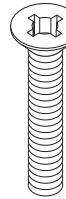

Flat
Head
Screw

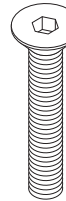

Flat
Head
Cap
Screw

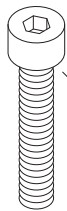

Cap
Screw



Carriage
Bolt



Flange
Bolt



Button
Head
Screw



Tap
Screw



External
Retaining
Ring



Internal
Retaining
Ring



E-Clip



Set
Screw

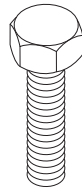

Hex
Bolt



Key



Flat Washer



Lock
Washer



Hex
Nut

LINES ARE 1MM APART



5mm
10mm
15mm
20mm
25mm
30mm
35mm
40mm
45mm
50mm
55mm
60mm
65mm
70mm
75mm

LINES ARE 1/16" INCH APART

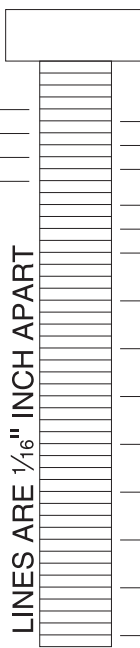

1/4"
3/8"
1/2"
5/8"
5/16"
7/16"
9/16"
3/4"
7/8"
1"
1 1/4"
1 1/2"
1 3/4"
2
2 1/4"
2 1/2"
2 3/4"
3

WASHERS ARE MEASURED BY THE INSIDE DIAMETER



Lock
Nut



Wing
Nut

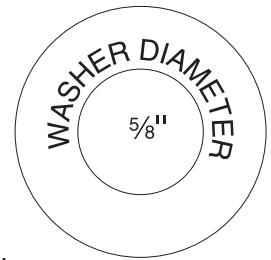

WASHER DIAMETER
5/8"

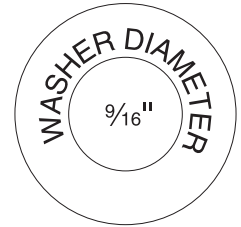

WASHER DIAMETER
9/16"

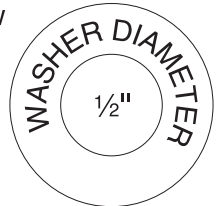

WASHER DIAMETER
1/2"



WASHER DIAMETER
7/16"

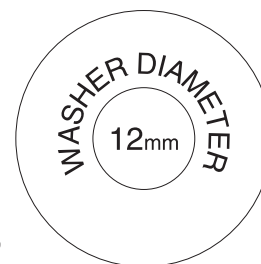

WASHER DIAMETER
12mm



WASHER DIAMETER
3/8"



WASHER DIAMETER
4mm

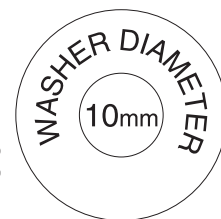

WASHER DIAMETER
10mm



WASHER DIAMETER
5/16"



WASHER DIAMETER
5mm



WASHER DIAMETER
1/4"

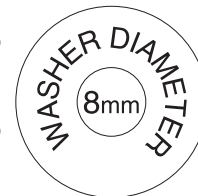

WASHER DIAMETER
8mm

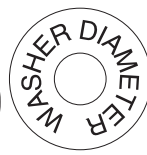

WASHER DIAMETER
6mm



WASHER DIAMETER
#10



Inventory

The following is a list of items shipped with your machine. Before beginning setup, lay these items out and inventory them.

If any non-proprietary parts are missing (e.g. a nut or a washer), we will gladly replace them; or for the sake of expediency, replacements can be obtained at your local hardware store.

NOTICE

If you cannot find an item on this list, carefully check around/inside the machine and packaging materials. Often, these items get lost in packaging materials while unpacking or they are pre-installed at the factory.

Box 1	Qty
• Shaper Unit	1
• Magnetic Switch	1
• FOR/REV Switch.....	1

Box 2	Qty
• Fence Assembly.....	1
• Fence Faces.....	1

Box 3:

• Handwheel	1
• Miter Gauge	1
• Handle for Handwheel	1
• Spindle 1/2"	1
• Spindle 3/4"	1
• Spindle 1"	1
• Spindle Nut 1/2"	2
• Spindle Nut 3/4"	2
• Spindle Nut 1"	2
• Spacers*	18
• Draw Bar & Nut	1
• Spindle Wrench Set.....	3
• Safety Guard	1
• Safety Guard Shaft	1
• Starting Pin	3
• Hold Downs	4
• Hold Down Bars	2
• Hold Down Brackets	4
• Hex Wrench 5mm.....	1
• Spindle Washer 1/2"	2
• Spindle Washer 3/4"	2
• Spindle Washer 1"	2
• Hardware Bag	1
—Set Screw 5/16"-18 x 3/8"	4
—Hex Nuts 5/16"-18.....	4
—Flat Washer 5/16"	4
—Flat Head Screw 5/16"-18 x 1 1/2".....	4
—Hex Nuts 1/4"-20.....	2
—Flat Washers 1/4"	4
—Knob Bolts 1/4"-20 x 3/8"	2
—Flat Hd Screws 1/4"-20 x 1"	2
• Extension Bracket w/Lock knob	1
• Lock Handle	1
• Guard Extension Bar.....	1
• Shaft Mount Bracket w/Set Screw.....	1
• Top Plastic Safety Guard.....	1
• Front Steel Safety Guard.....	1
• Padlock with Keys (Pre-Installed).....	

Note: Refer to **Page 38** for a detailed listing of spacers supplied.



Cleanup

The unpainted surfaces of your machine are coated with a heavy-duty rust preventative that prevents corrosion during shipment and storage. This rust preventative works extremely well, but it will take a little time to clean.

Be patient and do a thorough job cleaning your machine. The time you spend doing this now will give you a better appreciation for the proper care of your machine's unpainted surfaces.

There are many ways to remove this rust preventative, but the following steps work well in a wide variety of situations. Always follow the manufacturer's instructions with any cleaning product you use and make sure you work in a well-ventilated area to minimize exposure to toxic fumes.

Before cleaning, gather the following:

- Disposable rags
- Cleaner/degreaser (WD•40 works well)
- Safety glasses & disposable gloves
- Plastic paint scraper (optional)

Basic steps for removing rust preventative:

1. Put on safety glasses.
2. Coat the rust preventative with a liberal amount of cleaner/degreaser, then let it soak for 5–10 minutes.
3. Wipe off the surfaces. If your cleaner/degreaser is effective, the rust preventative will wipe off easily. If you have a plastic paint scraper, scrape off as much as you can first, then wipe off the rest with the rag.
4. Repeat **Steps 2–3** as necessary until clean, then coat all unpainted surfaces with a quality metal protectant to prevent rust.

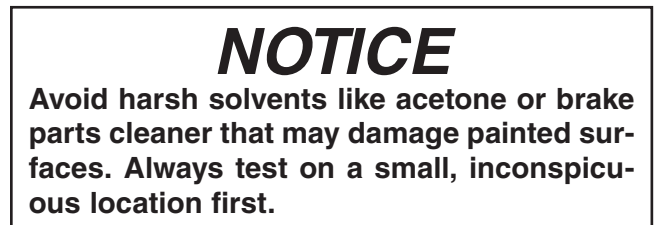
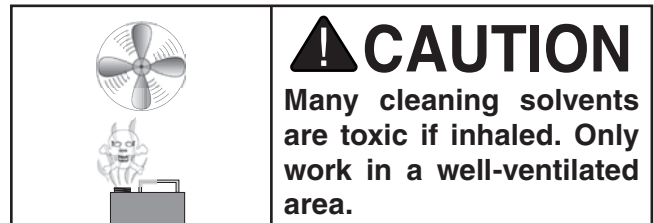
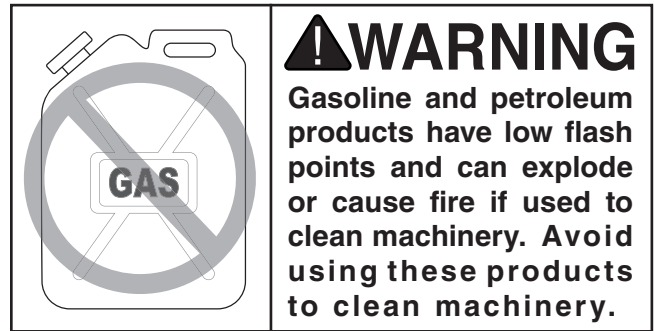

T23692—Orange Power Degreaser

A great product for removing the waxy shipping grease from the *non-painted* parts of the machine during clean up.



Figure 6. T23692 Orange Power Degreaser.



Site Considerations

Weight Load

Refer to the **Machine Data Sheet** for the weight of your machine. Make sure that the surface upon which the machine is placed will bear the weight of the machine, additional equipment that may be installed on the machine, and the heaviest workpiece that will be used. Additionally, consider the weight of the operator and any dynamic loading that may occur when operating the machine.

Space Allocation

Consider the largest size of workpiece that will be processed through this machine and provide enough space around the machine for adequate operator material handling or the installation of auxiliary equipment. With permanent installations, leave enough space around the machine to open or remove doors/covers as required by the maintenance and service described in this manual. **See below for required space allocation.**

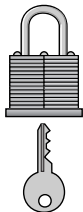
	<p>CAUTION</p> <p>Children or untrained people may be seriously injured by this machine. Only install in an access restricted location.</p>
---	--

Physical Environment

The physical environment where the machine is operated is important for safe operation and longevity of machine components. For best results, operate this machine in a dry environment that is free from excessive moisture, hazardous chemicals, airborne abrasives, or extreme conditions. Extreme conditions for this type of machinery are generally those where the ambient temperature range exceeds 41°–104°F; the relative humidity range exceeds 20%–95% (non-condensing); or the environment is subject to vibration, shocks, or bumps.

Electrical Installation

Place this machine near an existing power source. Make sure all power cords are protected from traffic, material handling, moisture, chemicals, or other hazards. Make sure to leave enough space around machine to disconnect power supply or apply a lockout/tagout device, if required.

Lighting

Lighting around the machine must be adequate enough that operations can be performed safely. Shadows, glare, or strobe effects that may distract or impede the operator must be eliminated.

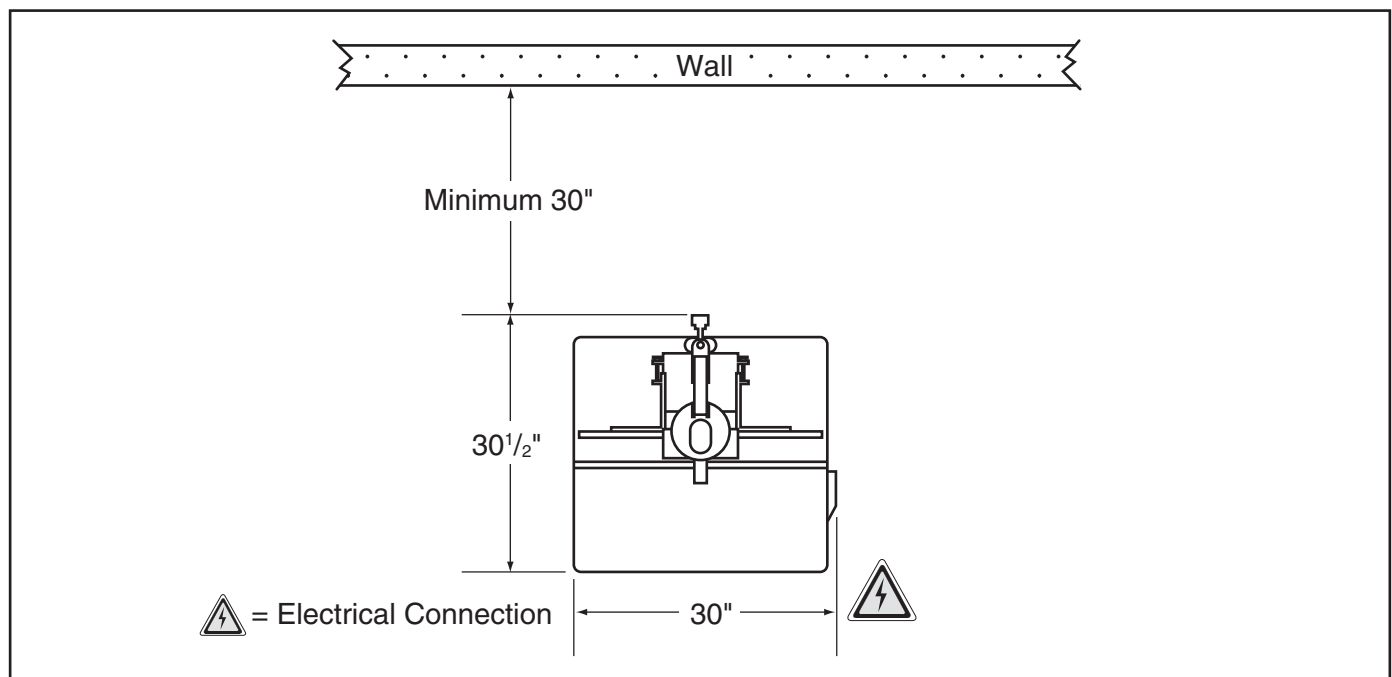

Figure 7. Minimum working clearances.



Assembly

The machine must be fully assembled before it can be operated. Before beginning the assembly process, refer to **Needed for Setup** and gather all listed items. To ensure the assembly process goes smoothly, first clean any parts that are covered or coated in heavy-duty rust preventative (if applicable).

Most of your Model G1026 has been assembled at the factory, but some parts must be assembled or installed after delivery.

To assemble the shaper:

1. Remove the motor cover from the shaper cabinet by removing six screws that hold it in place.
2. Remove the six hex bolts, hex nuts and flat washers and the two motor braces shown in **Figure 8**.

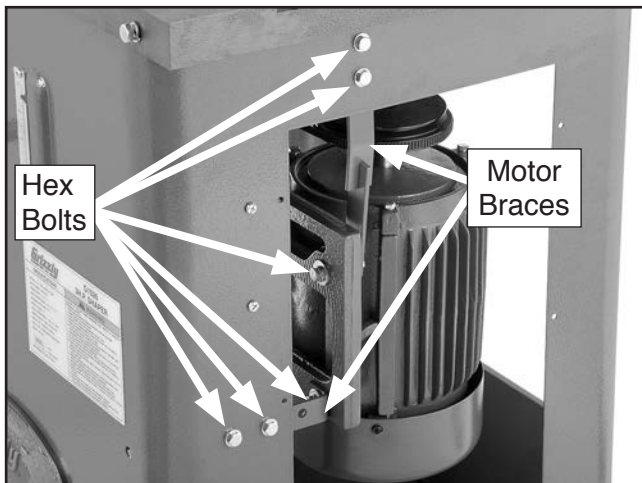

Figure 8. Motor braces and hex bolts.

3. Re-install all the fasteners removed in **Step 2**.

4. Slide the grommet plate, FOR/REV switch, and magnetic switch between the motor and the cabinet (see **Figure 9**) and remove the grommet plate and switches from the cabinet.



Figure 9. Removing magnetic switch from cabinet.

5. Re-install the motor cover.
6. Install the grommet plate, as shown in **Figure 10**, using the screws and nuts already mounted in the motor cover.

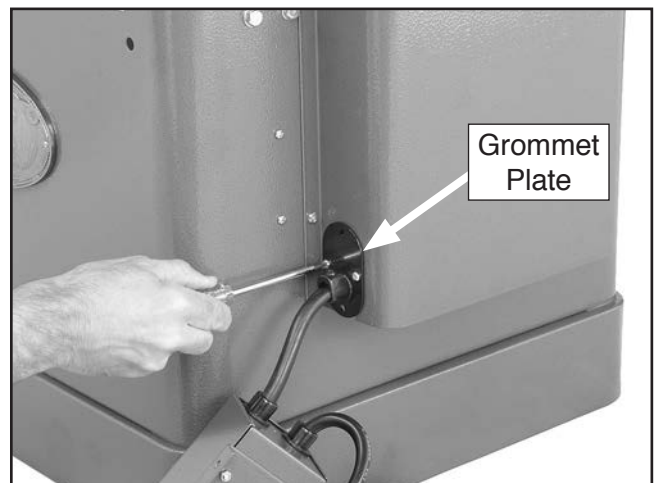

Figure 10. Securing grommet to motor cover.



7. Mount the FOR/REV switch to the cabinet, as shown in **Figure 11**, using the screws already mounted in the cabinet at that location.

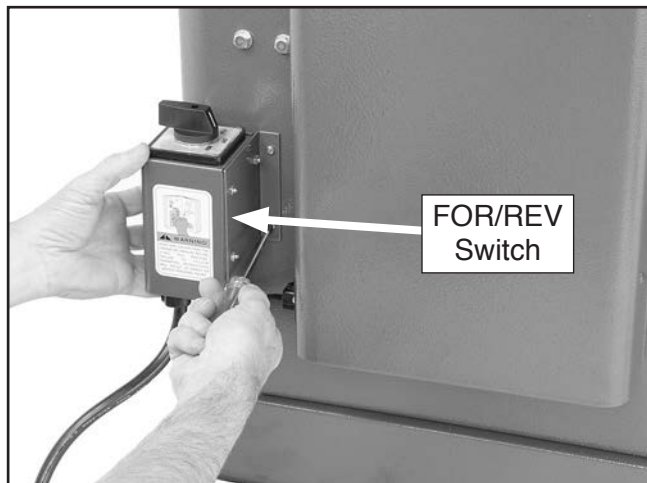

Figure 11. Securing FOR/REV switch to cabinet.

8. Mount the magnetic switch to the cabinet, as shown in **Figure 12**, using the screws already mounted in the cabinet at that location.



Figure 12. Securing mag switch to cabinet.

9. Slide the handwheel onto the handwheel shaft shown in **Figure 13**.



Figure 13. Location of handwheel shaft.

10. Tighten the handwheel set screw against the flat part of the handwheel shaft.
11. Thread the handle into the handwheel, and tighten the hex nut on the handle against the handwheel.



Spindle

Each of the three spindles that come with the Model G1026 is sized to work efficiently with different sized cutters and spacers. The spindles must be inserted correctly and remain securely locked in the machine in order to produce quality work. When installing and changing spindles, make sure the spindle seats snugly and that there is enough drawbar threaded into the bottom of the spindle to safely secure it in place.

⚠️ WARNING

Incorrect assembly can allow the spindle and cutter to fly off the machine, which could cause injury or death. Make certain the spindle is properly assembled before operating the Shaper. If you are uncertain of any aspect of this assembly, please review these instructions again or contact our Customer Service.

To install a spindle:

1. Remove the hex nuts from the spindle and the drawbar nut from the drawbar.
2. Thread the drawbar approximately 10-15 turns into the bottom of the spindle. The drawbar has two threaded ends. One of them remains exposed (see **Figure 14**).

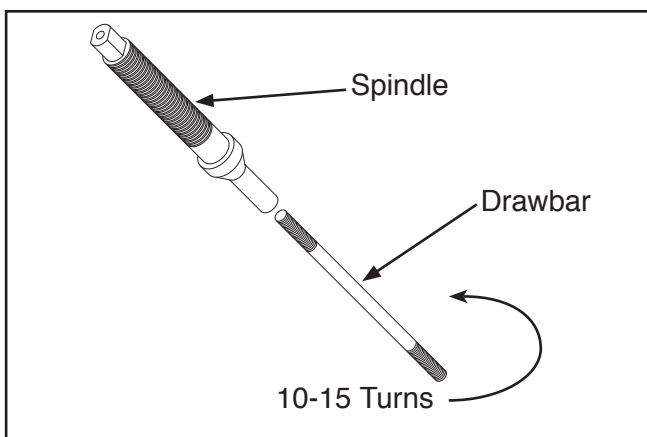

Figure 14. Spindle and drawbar.

3. Place the spindle/drawbar into the spindle cartridge at the top of the table. Line up the keyway on the spindle with the locating pin at the top of the spindle cartridge (see **Figure 15**). You will feel the spindle seat itself.

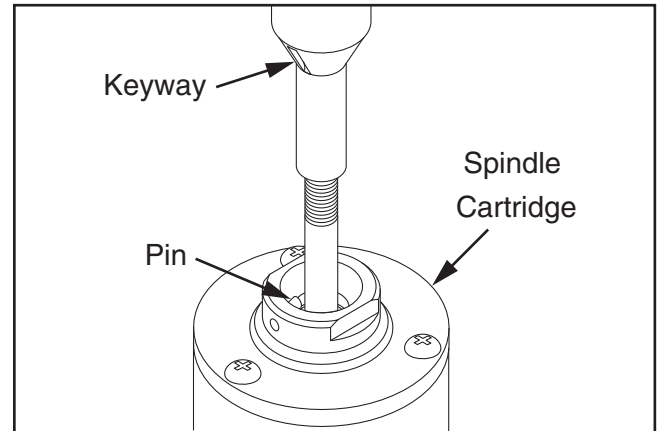

Figure 15. Inserting the spindle into place.

⚠️ CAUTION

Make sure the spindle keyway and pin are aligned and properly seated before tightening the drawbar nut. Improper assembly can create an unsafe condition and possible injury to the operator.

4. Thread the drawbar nut, tapered side up, onto the bottom of the drawbar until it stops below the spindle housing cartridge (see **Figure 16**).

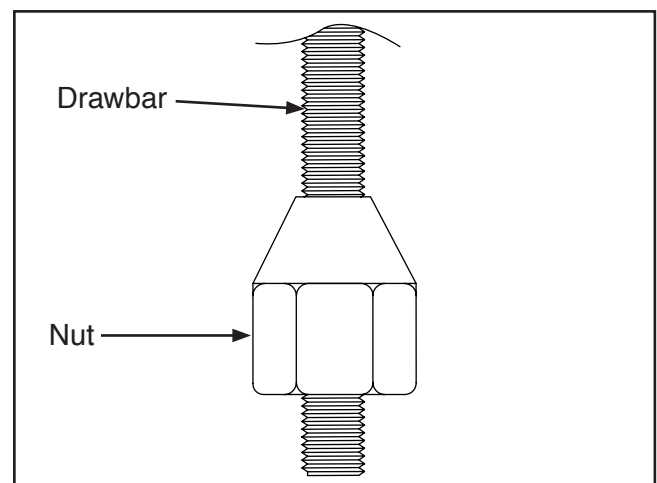

Figure 16. Nut threaded onto drawbar.



5. Place the spindle wrench on top of the spindle, so it fits over the head of the spindle. Place a 17mm wrench on the drawbar nut (see Figure 17).

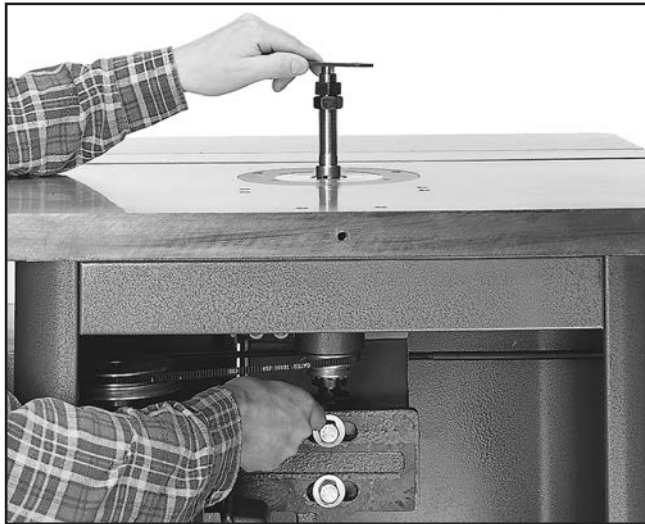

Figure 17. Tightening the drawbar nut.

6. Hold the spindle in place and tighten the drawbar nut. **DO NOT** use excessive force.

Table Inserts

The Model G1026 is supplied with three table inserts which give you four possible opening diameters in the shaper table surface. Use the smallest opening that a particular cutter will allow. This offers more support for the workpiece and reduces the amount of chips that can fall into the machine.

The correct spindle opening will also allow any unused portion of the cutter to remain below the table surface—increasing operator protection.

There are two aluminum table inserts and one cast-iron table insert. The cast-iron table insert *must* be flush with the top of the table.

To adjust the insert:

1. Remove the three Phillips head screws that hold the cast-iron insert in place.
2. Using a straightedge and a flathead screwdriver, turn the barrel screws clockwise or counterclockwise to level the cast iron insert with the table, as shown in Figure 18.

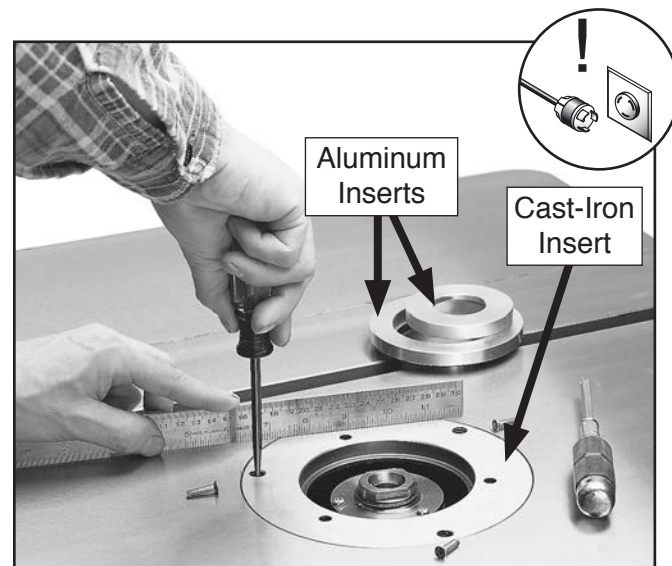

Figure 18. Leveling table insert.

3. Replace and tighten the Phillips head screws and inspect with a straightedge.



Extension Wing

The cast iron wing extends your work surface area to provide support for larger workpieces.

To install the extension wing:

1. Make sure the contact surfaces are free of dirt or grit.
2. Remove the (3) $\frac{3}{8}$ -16 x $1\frac{1}{4}$ " hex bolts and lock washers already mounted to the table.
3. Insert the hex bolts with lock washers through the wing and thread them into the holes at the front of the shaper. Leave the bolts loose, for now.
4. Raise the wing on one side and make sure it is flush with the table edge, then tighten the first bolt (see **Figure 19**).

Note: *By raising or lowering the far end of the wing, you can locate the center of the wing flush with the shaper table.*



Figure 19. Installing extension wing.

5. Secure the center bolt.

6. Make sure the wing edge is flush at the first two bolts and that the bolts are tight.

Note: *The end of the wing at the last bolt may not be flush with the surface of the table. Don't be alarmed.*

7. Adjust the wing up or down at the last bolt (see **Figure 20**). If necessary, use a clamp and some wood blocks to make the two surfaces flush. Tighten the final bolt when the two surfaces are flush.



Figure 20. Adjusting to ensure flatness.



8. Inspect your results with a good-quality straightedge.

— If the wing is slightly tilted up or down, place some masking tape along the whole length, between the table and the wing. Place the tape above the bolts to lower the wing (see **Figure 21**) or below the bolts (see **Figure 22**) to raise it.

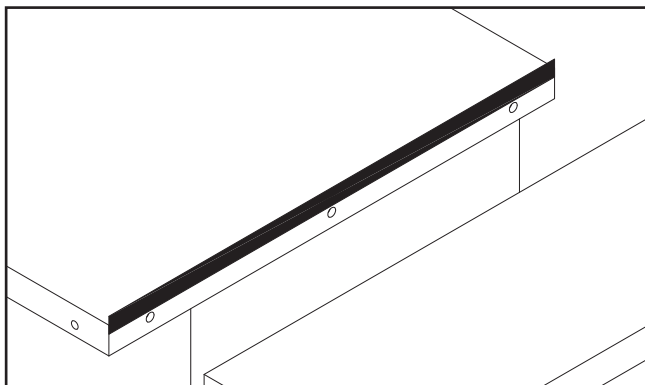

Figure 21. Masking tape location for lowering wing.

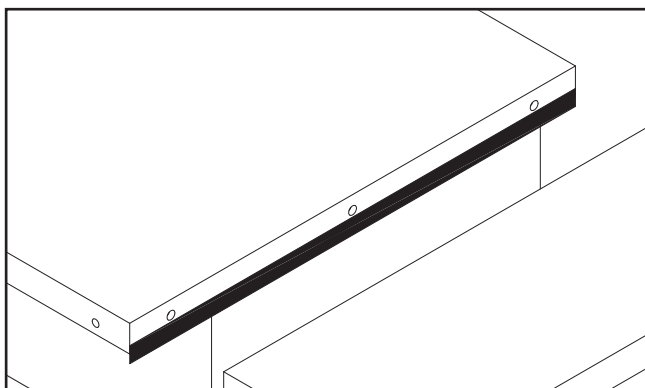

Figure 22. Masking tape location for raising wing.

10. Following adjustments, tighten the hex bolts in the sequence they were installed.

Fence Assembly

To install the fence assembly:

1. KEEP SHAPER DISCONNECTED FROM POWER!
2. Attach the fence assembly to the table, as shown in **Figure 23**, with the cap screws and lock washers already mounted to the table.

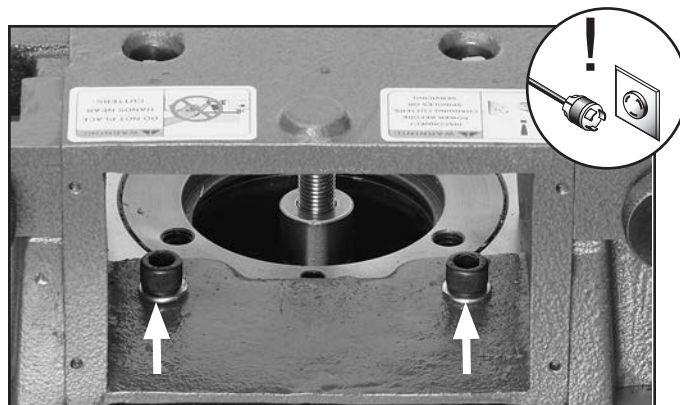

Figure 23. Fence assembly attachment location.

3. Secure the wooden fence pieces with the (4) $\frac{5}{16}$ "-18 x 1 $\frac{1}{2}$ " flat head screws, flat washers and hex nuts provided, as shown in **Figure 24**.

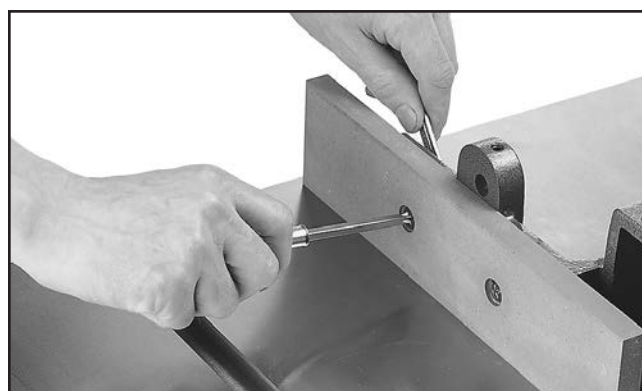

Figure 24. Attaching wooden fence assembly.



Safety Guard



To assemble and attach the safety guard:

1. Attach the shaft mount bracket (see **Figure 25**) to the back of the table with the (2) pre-installed hex bolts and lock washers.

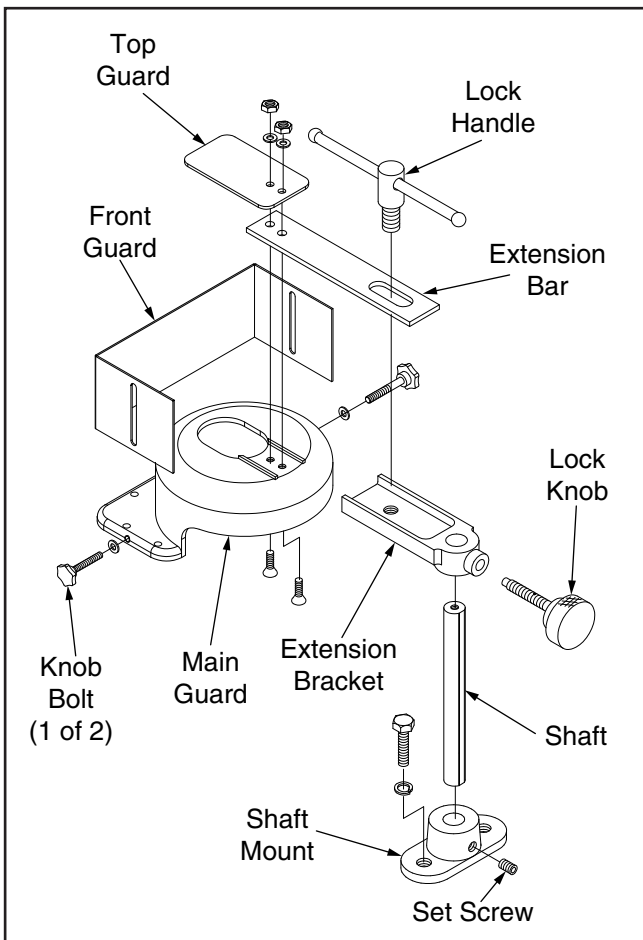

Figure 25. Safety guard assembly.

2. Insert the shaft into the bracket so the flat surface faces toward the rear, then secure it with the set screw.
3. Slide the extension bracket onto the shaft and secure with the lock knob.
4. Sandwich the extension bar between the top safety guard and the cutterhead guard, then secure the components with (2) ¼"-20 x 1" flat head screws, (2) ¼" flat washers, and (2) ¼"-20 hex nuts, as illustrated in **Figure 25**.
5. Attach the front safety guard to the sides of the cutterhead guard with (2) ¼"-20 x ½" knob bolts and (2) ¼" flat washers.
6. Secure the extension bar to the extension bracket with the lock handle to finish the assembly.

IMPORTANT: During operation, raise or lower the front safety guard so that it is as close to the workpiece as possible without interfering with workpiece travel past the cutter.

Always use the included safety guard or some type of guard when performing shaping operations.



Hold-Downs

Hold-downs are used to hold the workpiece flat on the table and snug against the fence as shown in **Figure 28**.

To assemble the hold-downs:

1. Slide two hold-down brackets onto each of the hold-down bars (one on the short arm, one on the long arm), as shown in **Figure 26**.

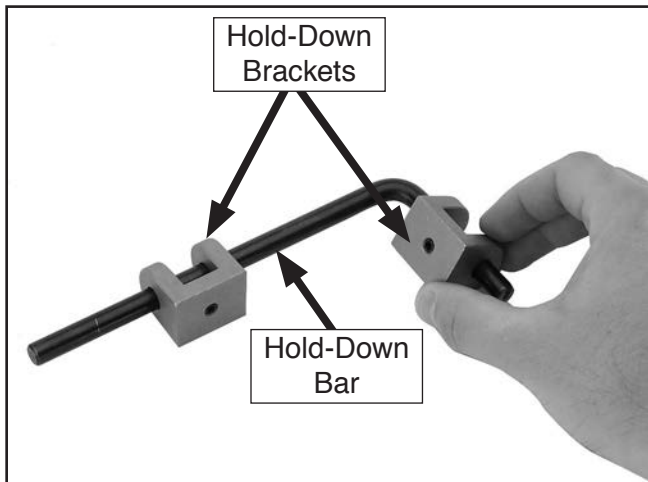

Figure 26. Brackets on hold-down bar.

2. Slide the long arm of the hold-down bars through the holes in the cast iron fence brackets, as shown in **Figure 27**.

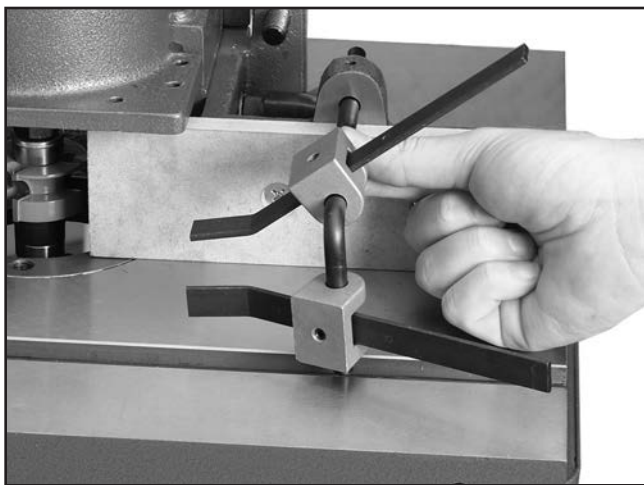

Figure 27. Inserting hold-down bar into fence bracket.

3. Partially screw the $\frac{5}{16}$ "-18 x $\frac{3}{8}$ " set screws into the hold-down brackets.
4. Slide each hold-down between a hold down bracket and hold down bar, as shown in **Figure 28**.

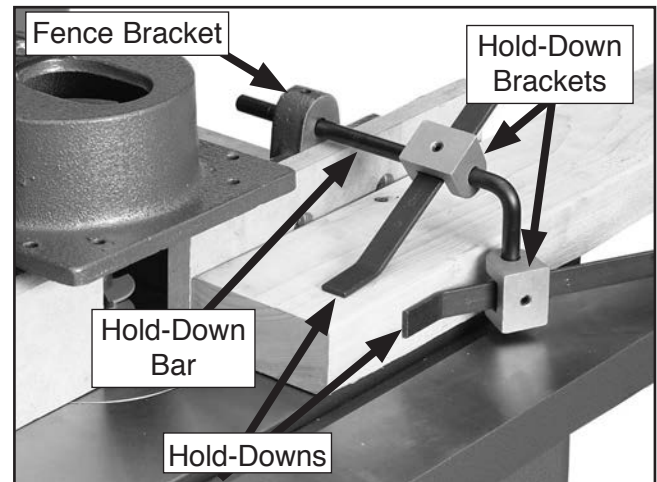

Figure 28. Using hold-downs on both sides.

5. Position the hold-downs according to the size of your workpiece.
6. Tighten the set screws in the fence brackets and the hold-down brackets to fix the position of the hold-downs.

Note: Remove the hold-down assembly when not in use.



Dust Collection

⚠ CAUTION

We recommend NOT operating the Model G1026 without an adequate dust collection system. This machine creates substantial amounts of wood dust while operating. Failure to use a dust collection system can result in short and long-term respiratory illness.

Recommended CFM at Dust Port: 400 CFM

Do not confuse this CFM recommendation with the rating of the dust collector. To determine the CFM at the dust port, you must consider these variables: (1) CFM rating of the dust collector, (2) hose type and length between the dust collector and the machine, (3) number of branches or wyes, and (4) amount of other open lines throughout the system. Explaining how to calculate these variables is beyond the scope of this manual. Consult an expert or purchase a good dust collection "how-to" book.

To connect a dust collection hose:

1. Connect the optional Model G4839 (see **Figure 29**) to the back of the fence assembly, then fit a 3" dust hose over the dust hood and secure in place with a hose clamp.

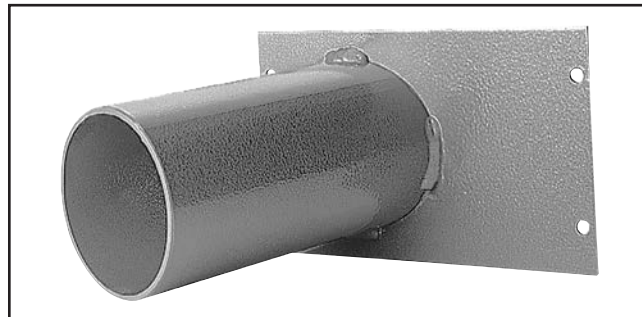

Figure 29. The Model G4839 dust hood. (Check with the current Grizzly catalog or www.grizzly.com to purchase.)

2. Tug the hose to make sure it does not come off.

Note: A tight fit is necessary for proper performance.



Test Run

Once assembly is complete, test run the machine to ensure it is properly connected to power and safety components are functioning correctly.

If you find an unusual problem during the test run, immediately stop the machine, disconnect it from power, and fix the problem **BEFORE** operating the machine again. The **Troubleshooting** table in the **SERVICE** section of this manual can help.

!WARNING

Serious injury or death can result from using this machine **BEFORE** understanding its controls and related safety information. **DO NOT** operate, or allow others to operate, machine until the information is understood.

!WARNING

DO NOT start machine until all preceding setup instructions have been performed. Operating an improperly set up machine may result in malfunction or unexpected results that can lead to serious injury, death, or machine/property damage.

To test run machine:

1. Clear all setup tools away from machine.
2. Unlock and remove padlock installed by factory on FOR/REV switch using included key (see **Figure 30**).



Figure 30. Padlock must be removed from FOR/REV switch before test run.

3. Connect machine to power supply.
4. Turn FOR/REV switch to forward (FOR) position press ON button. Verify motor operation, then press OFF button.
5. Turn FOR/REV switch to reverse (REV) position and press ON button.

Motor should run smoothly and without vibration or unusual problems or noises in both directions.

Correct any strange or unusual noises before operating machine further (see **Troubleshooting, Page 44**). Always disconnect machine from power when investigating or correcting problems. If problems persist, call Tech Support for help.

Congratulations! The **Test Run** is now complete. Continue to **Operations** section.



SECTION 4: OPERATIONS

Operation Overview

The purpose of this overview is to provide the novice machine operator with a basic understanding of how the machine is used during operation, so the machine controls/components discussed later in this manual are easier to understand.

Due to the generic nature of this overview, it is **not** intended to be an instructional guide. To learn more about specific operations, read this entire manual, seek additional training from experienced machine operators, and do additional research outside of this manual by reading "how-to" books, trade magazines, or websites.

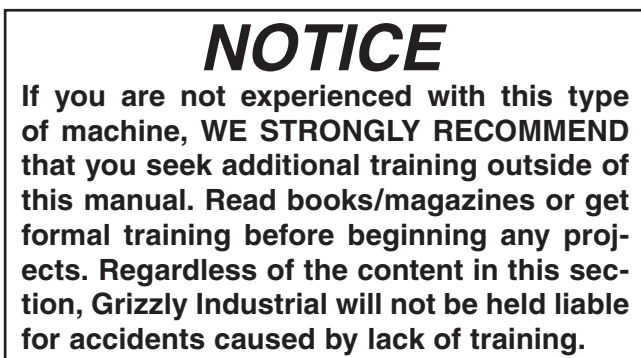
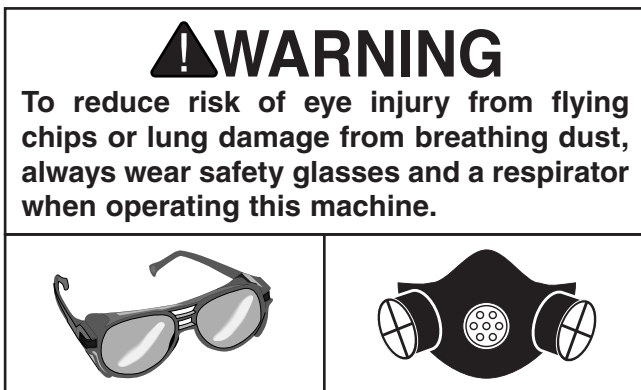

To complete a typical operation, the operator does the following:

1. Examines the workpiece to make sure it is suitable for cutting.
2. Installs the cutter onto the spindle and adjusts the spindle height for the operation.
3. Correctly adjusts the safety guard and fence boards for the operation and locks them in place.
4. Checks the outfeed side of the machine for proper support and to make sure the workpiece can safely move past the cutter without interference from other objects.
5. Places the workpiece on the infeed side of the machine and stabilizes it with hold-downs, jigs, or other safety workpiece holding devices.
6. Removes any clothing, apparel, or jewelry that may become entangled in shaper.
7. Puts on safety glasses and a respirator, and locates push sticks if needed.
8. Turns machine **ON**.
9. Verifies cutter rotation and feed directions.
10. Feeds workpiece through the cut while maintaining firm pressure on workpiece against both table and fence, while always keeping hands and fingers out of the cutting path.
11. Turns machine **OFF**.



Disabling & Locking Switch

The FOR/REV switch can be disabled and locked with a padlock. While the padlock is inserted through the hole on the switch, as shown in **Figure 31**, the motor cannot be started, which reduces the risk of accidental startup by children or unauthorized users.

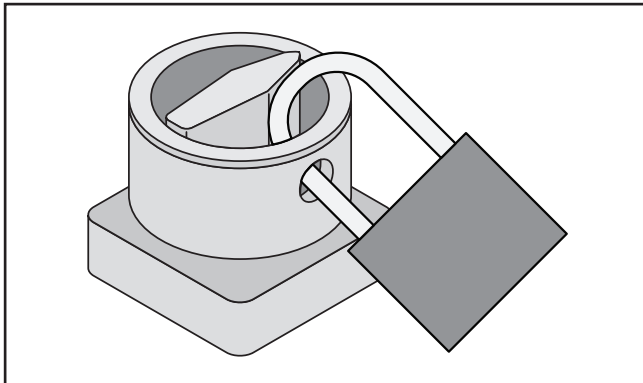

Figure 31. FOR/REV switch locked with the padlock to prevent the motor from starting.

⚠️ WARNING

Children or untrained people can be seriously injured by this machine. This risk increases with unsupervised operation. To help prevent unsupervised operation, disable and lock the switch before leaving machine unattended! Place key in a well-hidden or secure location.

NOTICE

The padlock shaft diameter is important to the disabling function of the switch. With any padlock used to lock the switch, test the switch after installation to ensure that it is properly disabled.

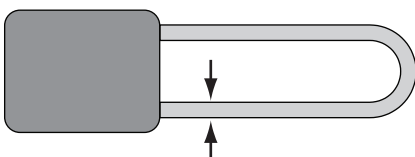

Figure 32. Minimum lock shaft requirements.

Workpiece Inspection

Some workpieces are not safe to cut or may require modification before they are safe to cut.

Before cutting, inspect all workpieces for the following:

- **Material Type:** This machine is intended for cutting natural and man-made wood products, laminate covered wood products, and some plastics. Cutting drywall or cementitious backer board creates extremely fine dust and may reduce the life of the bearings. This machine is NOT designed to cut metal, glass, stone, tile, etc.; cutting these materials with a table saw may lead to injury.
- **Foreign Objects:** Nails, staples, dirt, rocks and other foreign objects are often embedded in wood. While cutting, these objects can become dislodged and hit the operator, cause kickback, or break the cutter, which might then fly apart. Always visually inspect your workpiece for these items. If they can't be removed, DO NOT cut the workpiece.
- **Large/Loose Knots:** Loose knots can become dislodged during the cutting operation. Large knots can cause kickback and machine damage. Choose workpieces that do not have large/loose knots or plan ahead to avoid cutting through them.
- **Wet or "Green" Stock:** Cutting wood with a moisture content over 20% causes unnecessary wear on the blades, increases the risk of kickback, and yields poor results.
- **Excessive Warping:** Workpieces with excessive cupping, bowing, or twisting are dangerous to cut because they are unstable and often unpredictable when being cut. DO NOT use workpieces with these characteristics!
- **Minor Warping:** Workpieces with slight cupping can be safely supported if the cupped side is facing the table or the fence. On the contrary, a workpiece supported on the bowed side will rock during a cut and could cause kickback or severe injury.



Changing Cutter Rotation

Always check the direction of the cutter rotation before any shaping operation.

The G1026 is equipped with a FOR/REV (forward and reverse) switch, as shown in **Figure 33**. In most cases, the shaper should be run in the FOR direction.

In some instances, it will be necessary to flip the cutter over and reverse the cutter rotation.

Whenever possible, mount the cutter so the stock is milled on the bottom side (the side away from the operator). This does a better job and it is safer for the operator. Refer to **Rub Collars**, **Page 34**.



Figure 33. FOR/REV switch.

Speed Changes

The Model G1026 Shaper is equipped with a special high-speed V-belt. It is designed to withstand the vibration and sudden shock loads associated with the operation of a shaper.

To change spindle speeds:

1. DISCONNECT MACHINE FROM POWER!
2. Remove the rear cover, then loosen the two motor mount bolts shown in **Figure 34** and slide the motor toward the spindle assembly.

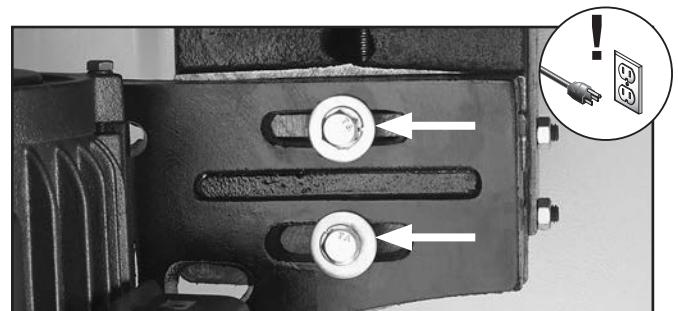

Figure 34. Location of motor mount hex bolts.

3. Move the V-belt to a sheave on the motor and spindle pulleys to select the desired speed (**see Figure 35**.)

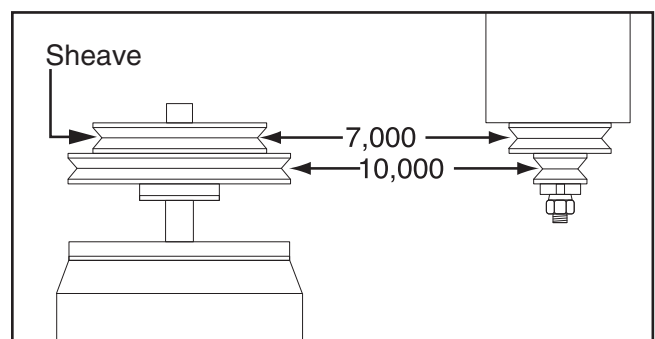

Figure 35. Speed change belt positions.

4. Slide the motor back into position and tighten the belt. When the belt is properly tensioned, there should be approximately $\frac{1}{4}$ " of deflection in the center of the belt when you press it with your thumb.
5. Tighten the motor mount bolts.
6. Spin the pulley to ensure proper tracking.
7. Re-install the rear cover.



Cutter Installation

Large cutters (3½" or greater) must be operated at 7,000 RPM; smaller cutters can be operated at 10,000 RPM. Always use the largest spindle size possible, and never use a cutter bore more than one size larger than the spindle size.

Tools Needed:	Qty
Spindle Wrenches	2

To install a cutter:

1. DISCONNECT MACHINE FROM POWER!
2. Loosen the knurled lock knob and temporarily move the main safety guard out of the way.
3. If needed, place an appropriate spacer or collar at the base of the spindle for support.
4. Place the cutter on the spindle. Make sure the rotation is correct for your application.
5. Use spacers or collars to suit your particular application.
6. Place a spindle washer above the cutter and screw on the nut and locknut, as shown in **Figure 36**.

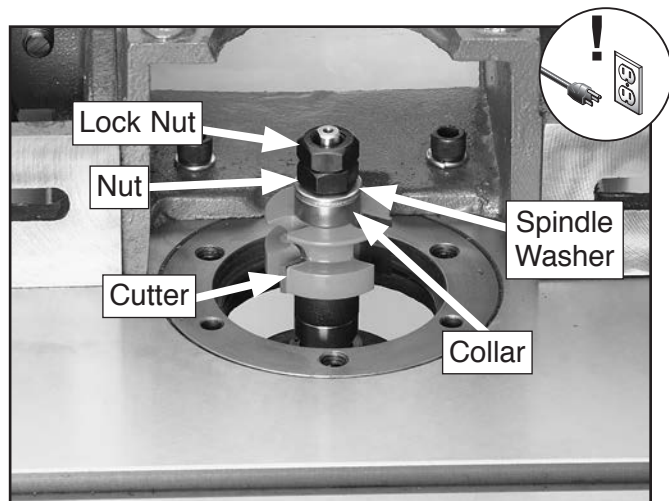

Figure 36. Cutter and fasteners.

7. Tighten the nuts while holding the spindle stationary. Place a spindle wrench on the notches at the top of the spindle for leverage, as shown in **Figure 37**.
8. Replace the safety guard.

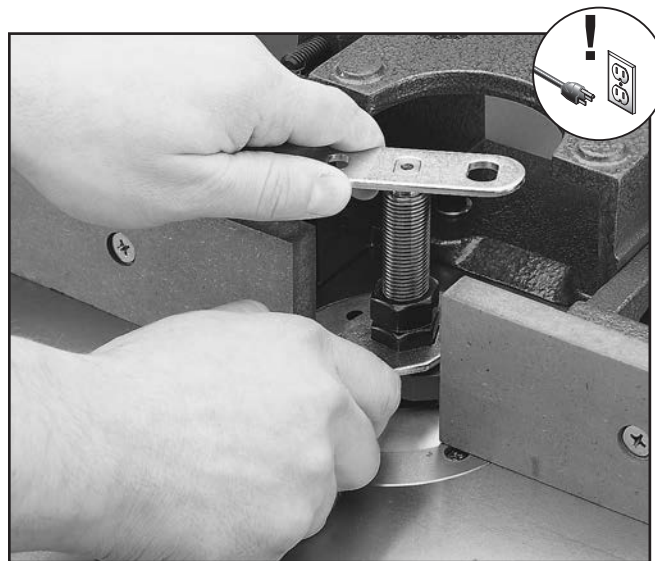

Figure 37. Tightening spindle nuts.

Spindle Height

To adjust the cutter height:

1. Loosen the spindle lock (see **Figure 38**).

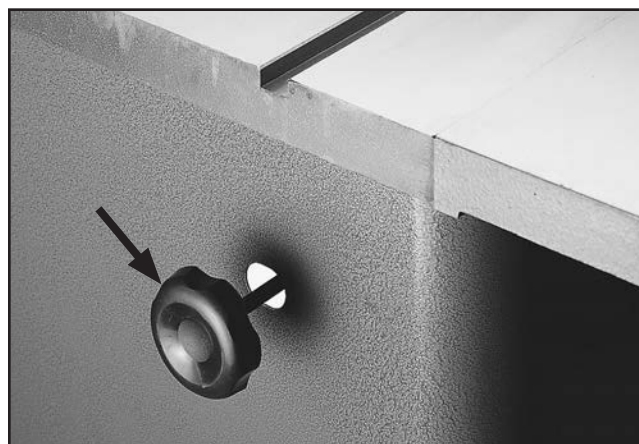

Figure 38. Spindle lock knob.

2. Move the spindle up or down with the elevation handwheel until the desired position is obtained.
3. Lock the spindle into position.



Fence Adjustment

The fence is a two-piece adjusting system. Each fence is independently adjustable to compensate for different cutting thicknesses and special shaping applications. One turn of the knob moves the split fence approximately $\frac{5}{64}$ " (.078").

To adjust the fence:

1. Loosen the fence lock handle (see **Figure 39**).
2. Turn the fence adjustment knob (see **Figure 39**) until the fence is set to the desired position.

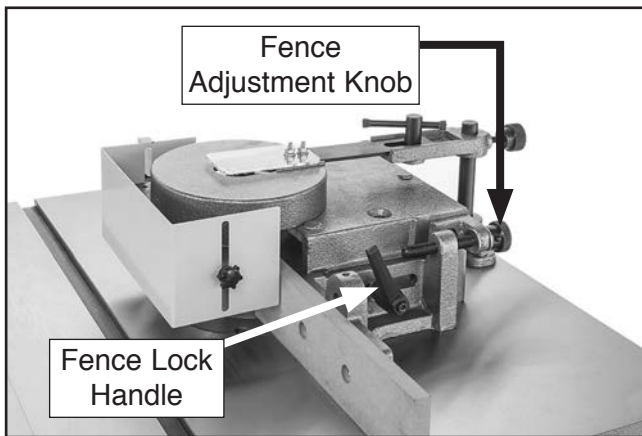

Figure 39. Location of fence adjustment controls.

3. Tighten the fence lock handle.

Note: More detailed information concerning fence adjustments is covered in **Straight Shaping** on **Page 32**.

Safety Guard Adjustment

The safety guard (see **Figure 40**) protects the user from exposure to the cutter and chips thrown by it. To minimize the risk of injury, the guard must be adjusted so it encloses as much of the spindle area as possible, while still allowing the workpiece to pass through the cut. Typically, this means the guard is positioned to just clear the top of the workpiece.

To position the safety guard, loosen the knob bolts (see **Figure 40**) and raise or lower the guard as needed. Tighten the knob bolts to secure the setting.

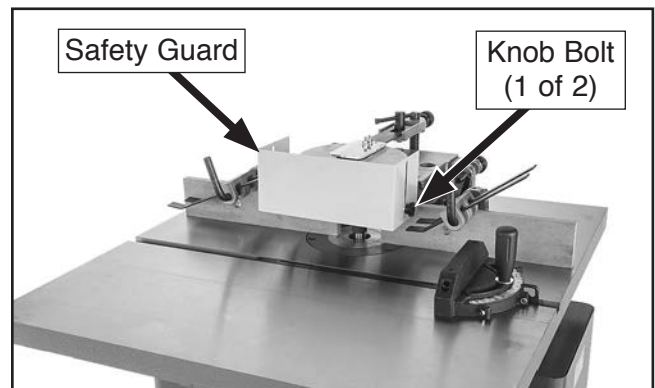
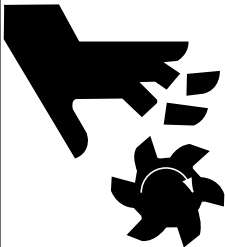

Figure 40. Location of safety guard.

	<p>⚠ WARNING</p> <p>All guards MUST be installed on your shaper before operating it. Shapers can quickly cause serious injury if some kind of guard is not used. To reduce your risk of injury, read and follow the entire Owner's Manual carefully and do additional research on shop-made guards and safety jigs.</p>
--	---



Straight Shaping

The fence assembly is a two-piece, independently adjustable system. When removing material from the whole face of your workpiece, the outfeed fence can be adjusted to provide support for the workpiece as it passes over the cutter, or it can be set up for partial face removal.

!WARNING

Attempting to operate the shaper without proper knowledge of the machine could cause serious injury or death! Read through the entire manual carefully before attempting to make any cuts with your shaper.

When removing material from the entire board face, observe the following steps:

1. Loosen the locking handles that hold the fences in place (see **Figure 41**).

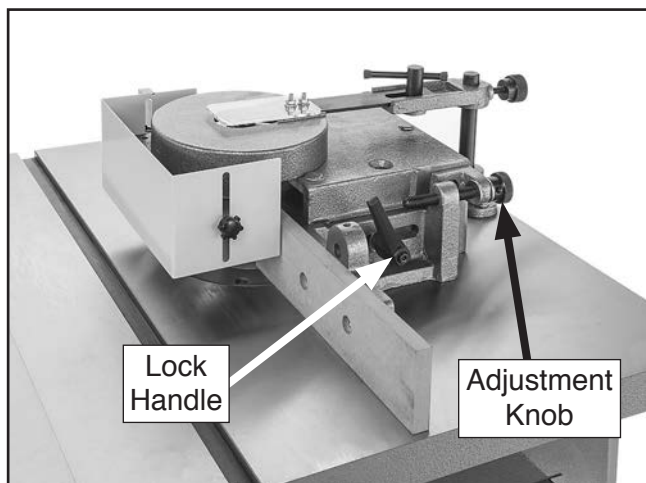
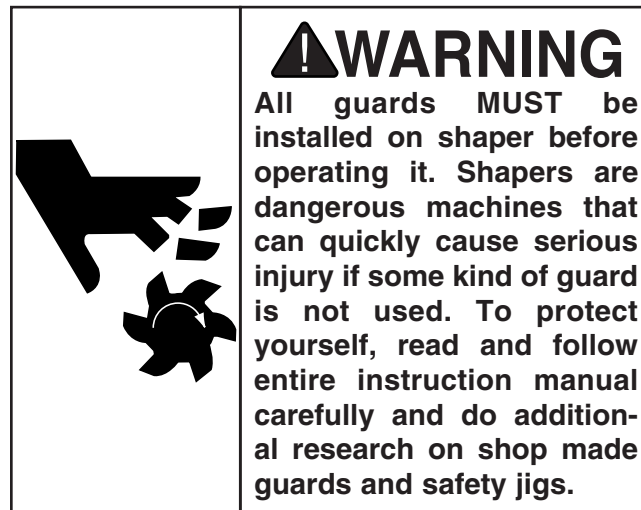

Figure 41. Fence adjustments.

2. Adjust the infeed fence by turning the knurled adjustment knob until the workpiece contacts the cutter in the desired location.
3. Use a test piece at least 24" long to determine the best setting.



4. Lock the infeed fence in position with the lock handle.
5. Turn the shaper **ON** and advance a test sample of the desired cut about 8", then stop. Swing the test piece away from the cutter and turn the machine **OFF**.
6. When the cutter comes to a complete stop, adjust the outfeed fence to support the new profiled edge, as shown in **Figure 42**.

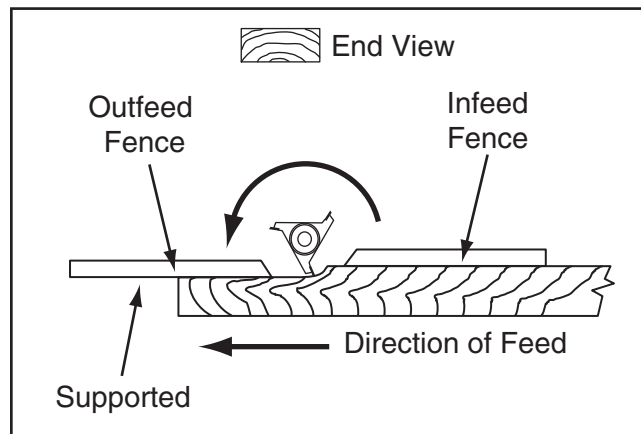

Figure 42. Support workpiece as it is fed.



!WARNING

The miter gauge should not be used to feed material along the fence face when edge shaping. Use a push stick and hold-downs to keep the workpiece in position. The fence may not always be perfectly parallel to the miter slot; therefore, using the miter gauge can cause binding and possible kickback of the workpiece towards the operator. Serious personal injury could occur if this happens.

If the face of the workpiece will only be partially removed, observe the following steps:

1. Adjust the infeed fence approximately to the desired depth of cut. Lock the infeed fence in place.
2. Use a straightedge to adjust the outfeed fence to the same plane as the infeed fence. Lock the outfeed fence in place.
3. Set the right and left wood faces so they barely clear the cutter. This allows the maximum support possible for the workpiece when passing the cutter. Remember to tighten the wood facing before starting the shaper.
4. Turn the shaper **ON**.
5. Run a test piece through the shaper (see **Figure 43**).

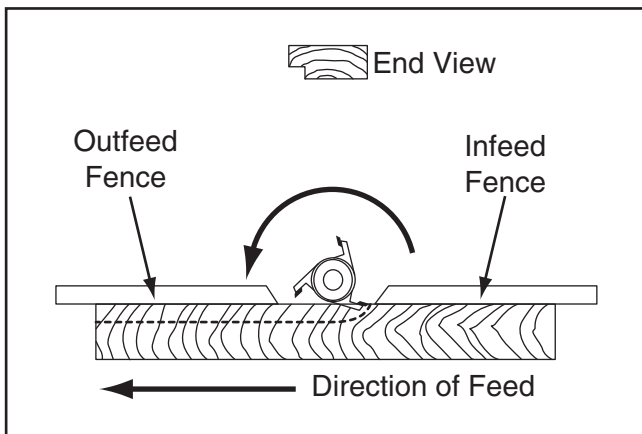

Figure 43. Partial feed fence adjustment.

6. Turn the shaper **OFF**.

!WARNING

The sound of this machine when it is running may be less than that of other devices such as a dust collector, which may be running at the same time. Because of this, it may be difficult to determine if the machine is **ON** merely by listening. It is necessary to make certain that this machine is **OFF** before attempting any setup or adjustments. Otherwise, serious personal injury could occur.

NOTICE

Always cut the end grain first when putting an edge around the perimeter of your workpiece to minimize tearout (see **Figure 44**).

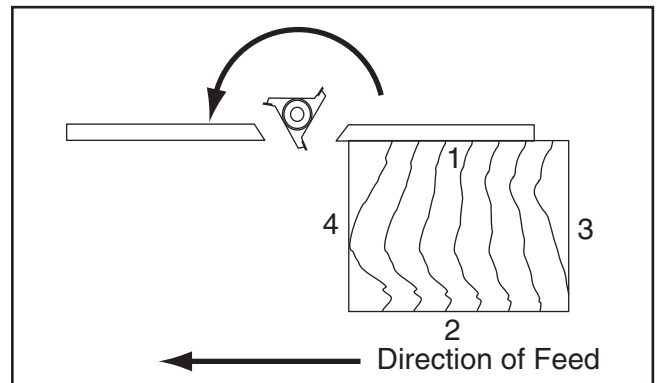

Figure 44. Cut end grain first.



Shaping Small Stock

Shaping small stock is inherently dangerous on a shaper. Consider making a zero-clearance fence (see **Figure 45**) to provide more support than a standard fence and reduce tearout on narrow or fragile stock.

⚠ CAUTION

Always use hold-downs or featherboards when shaping small or narrow stock. These devices will keep your hands away from the spinning cutterhead and support stock sufficiently to allow a safe and effective cut. Failure to follow this warning may lead to severe personal injury.

To make a zero-clearance fence:

1. DISCONNECT MACHINE FROM POWER!
2. Remove the wood facing and fasteners on the fences.
3. Place a 1 x 4 over the fence mounts and mark and drill four holes for securing the board to the mounts.
4. Transpose an outline of the spindle, cutter, and its components onto the board, leaving room for moving parts so they will not hit the board.
5. Using a bandsaw, cut out the outline.
6. Cut notches in top of board for attaching hold-downs (see **Figure 45**), secure it to the fence mounts with the fasteners removed in **Step 2**.

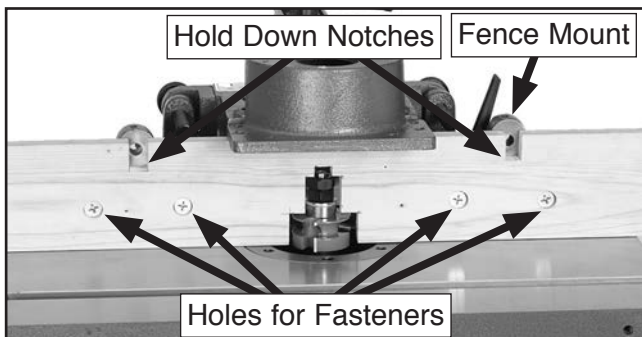

Figure 45. Example of a zero-clearance fence.

Rub Collars

Rub collars are used when shaping curved or irregular workpieces, such as arched doors or round table tops, and to limit the depth of your cut.

There are two types of rub collars—solid and ball-bearing. We recommend using ball bearing collars and we carry an extensive line that is designed for use with Grizzly shapers. See our current catalog or website for listings.

Rub collars may be used in any of the following positions:

1. **Rub collar below the cutter:** When the rub collar is placed below the cutter, as shown in **Figure 46**, the progress of the cut can be observed. However, any unintentional movement may lift the workpiece into the cutter, damaging your work and creating a dangerous situation. *We DO NOT recommend using the rub collar in this position.*

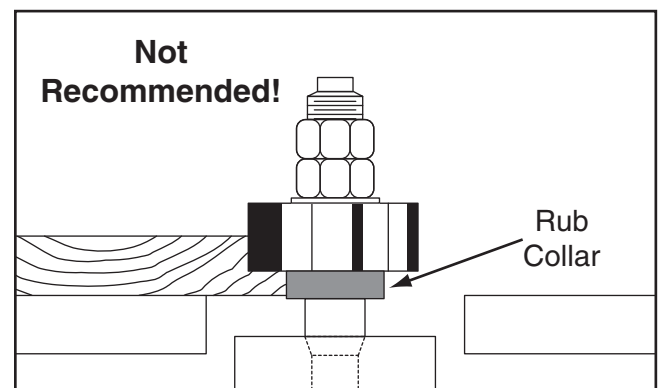

Figure 46. Cutting with rub collar below cutter.



Irregular Shaping

2. **Above the cutter:** When the rub collar is used above the cutter, the cut cannot be seen (see **Figure 47**). This offers some advantage—the stock is not affected by slight variations in thickness and accidental lifting will not damage the workpiece. Simply correct any change in height by repeating the operation.

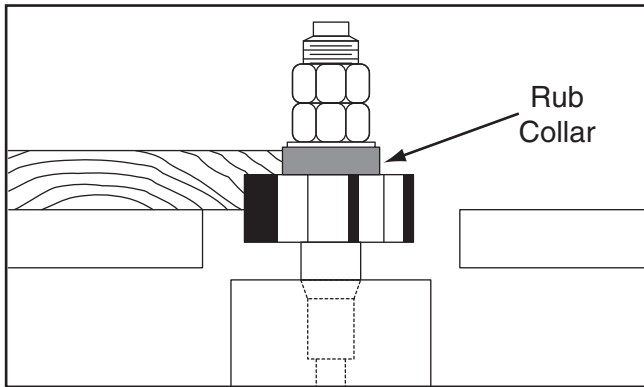

Figure 47. Cutting with rub collar above cutter.

3. **Between two cutters:** Using a rub collar between two cutters has the distinct advantage of performing two cuts at once or eliminating the need to change cutters for two different operations (see **Figure 48**). Notice that part of the edge is left uncut. The uncut portion rides on the rub collar.

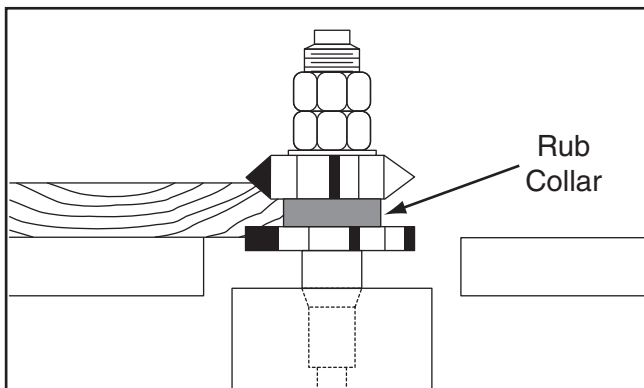

Figure 48. Using rub collar between cutters.

⚠ WARNING

Freehand shaping greatly increases the chance that the operator may lose control of the workpiece, which could result in serious personal injury. Therefore, a starting pin or support MUST be used to start an irregular shaping operation.

Irregular or freehand shaping takes a high degree of skill and dexterity. The fence assembly is not used in irregular shaping, so rub collars must be used. (See **Rub Collars** on **Page 34**).

When doing freehand work, a starting pin must be used. The purpose of the starting pin is to support the workpiece during the beginning of the cut. Your shaper is supplied with a starting pin that can be placed in one of the holes located in the shaper table. The work should be placed in the starting position using the starting pin for support, as shown in **Figure 49**.

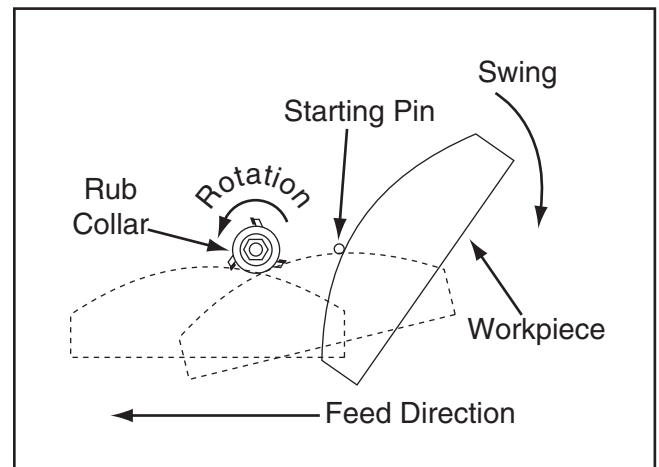

Figure 49. Using a starting pin for irregular shaping.

Next, swing the work into the cutter while holding the workpiece firmly against the starting pin. After the cut has been started, the work should be swung away from the starting pin and is supported just by the rub collar, as shown by the broken line positions shown in **Figure 49**.

ALWAYS FEED AGAINST THE ROTATION OF THE CUTTER.



! WARNING



All guards **MUST** be installed on your shaper before operating it. Shapers are dangerous machines that can quickly cause serious injury if some kind of guard is not used. To protect yourself, read and follow the entire manual carefully and do additional research on shop made guards and safety jigs.

To use a starting pin:

1. DISCONNECT MACHINE FROM POWER!
2. Remove the fence assembly.
3. Install the appropriate cutter for your application (see **Cutter Installation** on **Page 30**).
4. Check the cutter rotation (see **Changing Cutter Rotation** on **Page 29**).
5. Adjust the spindle height to align the cutter to the workpiece.
6. Insert a starting pin (see **Figure 50**) into the table surface, using the pin location that best supports your work.



Figure 50. Inserting starting pin.

7. Use some type of hold-down fixture and guard when doing freehand work (see **Figure 51**).

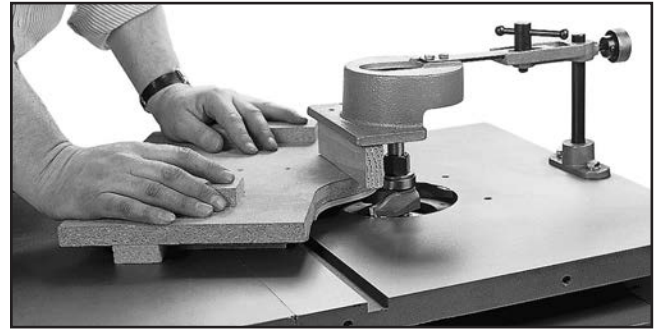

Figure 51. Use guard when doing freehand work. (Portion of guard removed for clarity.)

8. Make a sample cut on a piece of scrap wood.
9. If everything is correct, feed your workpiece along the cutter, using firm pressure to keep your work against the rub collar. Only feed against the cutter rotation.

! CAUTION

Incorrectly feeding stock—feeding with the rotation of the cutter—creates a potentially uncontrollable feed situation and may pull stock from your hands. This can result in serious personal injury.

Sometimes the starting pin will not be in the most advantageous position. If so, firmly clamp a board in the desired position to act as a starting pin (see **Figure 52**). Some type of pivot point **must** be used. Notice in **Figures 51 & 52** the operator is not exposed to the cutting edge of the cutter. Cutters are removing material from the bottom of the workpiece.



Figure 52. Use starting pin substitute when needed. (Guard removed for clarity.)



Pattern Work

When using a pattern, a rub collar or ball bearing can be positioned either above, below, or between cutters.

The pattern is usually used when the entire edge is to be shaped or when many duplicate pieces are needed. Pattern work is particularly useful when rough cutting irregular shapes oversize and then shaping the edge in a simple two-step operation. A pattern, when attached to a workpiece by adding toggle clamps, hand-holds, or other safety devices, make a fixture. **Figure 53** shows proper setup of pattern and bearing rub collar.

You have greater flexibility when choosing the correct diameter rub collar for pattern work than for non-pattern work. If you look at **Figure 53**, you will notice that the position of the pattern determines the depth of cut. In other words, your pattern size is dependent upon the inter-relationship of the rub collar cutting diameter, and the desired amount of material removed. Changing either the cutter or the rub collar will change the amount of material removed. Planning ahead, you can best decide which rub collars are best suited for your application.

Always perform test cuts on scrap stock to ensure pattern works as required.

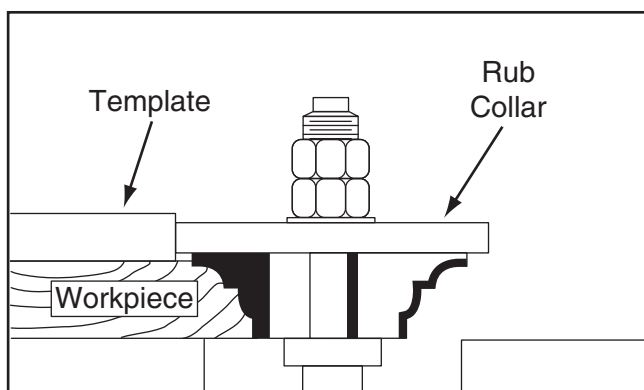

Figure 53. Position of pattern on workpiece and bearing size determine depth of cut.

Things to consider when making a pattern or fixture:

- Use a material that will smoothly follow rub collar, ball bearing or fence.
- Secure workpiece to a pattern (on sides that will not be cut) with toggle clamps, or fasten with wood screws.
- Make your fixture stable! Use proven methods and materials, and attach hand-holds for operator comfort and safety.
- Ensure clamps and hidden screws do not come into contact with cutter.
- Design your fixture so that all cutting occurs beneath workpiece.
- Always consider rub collar diameter for correct depth-of-cut when designing your pattern.
- Make sure your workpiece rests flat on work table, *not* on work fixture.
- Remember, there are tremendous cutting forces involved. Fixtures *must* be solid and stable, and any workpiece must be firmly secured.

NOTICE

Use care in designing and making fixtures. Clamps and screws cannot touch the cutter, and the fixtures must be stable in use, with the workpiece resting on the shaper table, not on the fixture. The workpiece must be fixed securely to the jig.



SECTION 5: ACCESSORIES

!WARNING

Installing unapproved accessories may cause machine to malfunction, resulting in serious personal injury or machine damage. To reduce this risk, only install accessories recommended for this machine by Grizzly.

NOTICE

Refer to our website or latest catalog for additional recommended accessories.

G4179—1/2 HP Power Feeder

If you do any kind of hand ripping or milling, you know what a big chore it can be especially with longer and wider stock. For those of you who want to increase production, upgrade or add on an extra stock feeder, we have one that will match virtually any application and budget.



Figure 54. G4179 Power Feeder.

W1159—Spacer 1/2" Bore, 1" OD, 1/4" High

W1160—Spacer 1/2" Bore, 1" OD, 3/8" High

W1161—Spacer 1/2" Bore, 1" OD, 1/2" High

W1162—Spacer 1/2" Bore, 1" OD, 3/4" High

W1163—Spacer 1/2" Bore, 1" OD, 1" High

Spacers allow you to position your shaper cutter anywhere on the spindle. Use them between cutters or stack them above the cutter to bear against the spindle nut. Every shaper owner needs a set of these on-hand.



Figure 55. Shaper spindle spacers.

W1110—1/2" Rub Collar, 1 1/8" Outside Dia.

W1111—1/2" Rub Collar, 1 1/4" Outside Dia.

W1112—1/2" Rub Collar, 1 3/8" Outside Dia.

W1113—1/2" Rub Collar, 1 1/2" Outside Dia.

W1114—3/4" Rub Collar, 1 5/8" Outside Dia.

W1116—3/4" Rub Collar, 1 3/4" Outside Dia.

W1118—3/4" Rub Collar, 1 7/8" Outside Dia.

W1119—3/4" Rub Collar, 2" Outside Dia.

W1120—3/4" Rub Collar, 2 1/8" Outside Dia.

W1122—3/4" Rub Collar, 2 5/8" Outside Dia.

If you do any kind of irregular shaping, rub collars are a must! Rub collars are used for shaping curved work such as cathedral doors, as well as many custom shapes. They are also used for limiting depth-of-cut, like guide bearings on router bits.



Figure 56. Ball bearing rub collars.

order online at www.grizzly.com or call 1-800-523-4777



D2057A—Heavy-Duty Shop Fox® Mobile Base

This patented base is the most stable on the market with outrigger type supports. Adjusts from 20" x 20" to 29½" x 29½". 700 lb. capacity. Weighs 34 lbs.



Figure 57. D2057A Shop Fox Mobile Base.

G4839—3" Dust Hood

This dust hood connects the G1026 to any 3" dust collection hose. Attaches to blade guard.

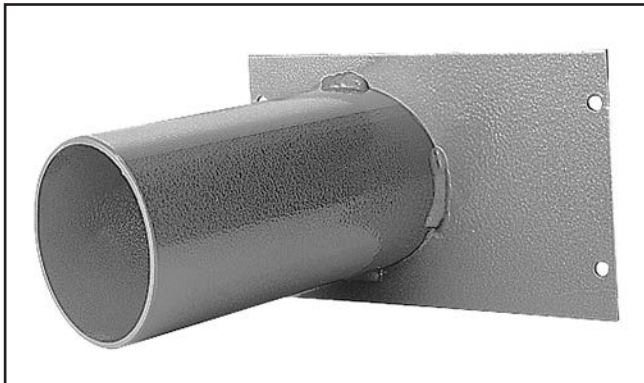

Figure 58. G4839 Dust Hood.

G1794—Bit Spindle

Router bit spindle for use with the G1026. For ¼" and ½" shank bits.



Figure 59. G1794 Bit Spindle.

D2271—Shop Fox® Roller Table

Use these versatile roller tables wherever you need extra workpiece support. Features all-steel welded construction and measures 19" x 65" long. Comes with 9 ball bearing rollers and has four independently adjustable legs for any leveling requirement. Adjustable in height from 26⅜" to 44⅞". Approximate shipping weight: 62 lbs. 1000 Lb. Capacity!



Figure 60. D2271 Shop Fox® Roller Table.

D4209—3"D x 6"L Flexible Hose



Figure 61. D4209 3" x 6" Flexible Hose.

W1316—3" Wire Hose Clamp

Hose clamps are used to connect flexible piping to dust hoods, blast gates and fittings. These Wire Hose Clamps measure 3" diameter.



Figure 62. W1316 3" Wire Hose Clamp.

order online at www.grizzly.com or call 1-800-523-4777



C2020—1/2" Cove

1/2" Bore, 2" Diameter, 1/2" Cutting Length

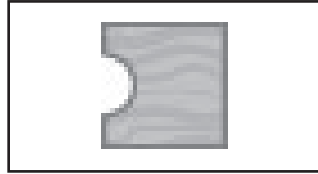

C2008—1/4" Rabbet

1/2" Bore, 2" Diameter, 1/4" Cutting Length

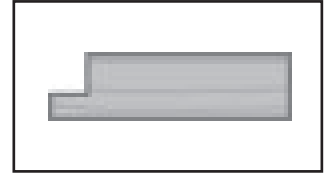
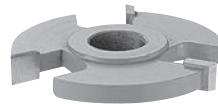

C2004—1/4" & 1/2" Quarter-Round

1/2" Bore, 2 1/8" Diameter, 1/32" Cutting Length

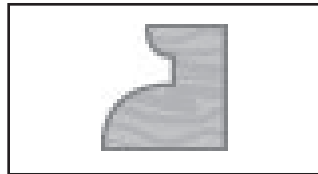
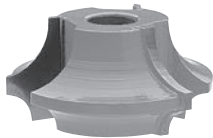

C2009—1/2" Rabbet

1/2" Bore, 2" Diameter, 1/2" Cutting Length

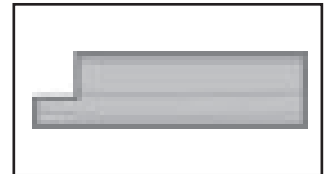
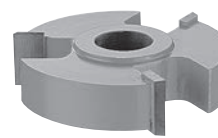

C2007—1" Straight

1/2" Bore, 2" Diameter, 1" Cutting Length

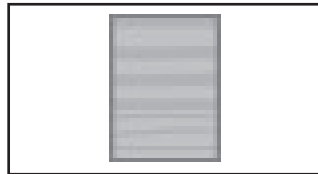
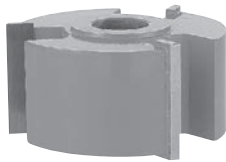

C2013—Drop Leaf Cove

1/2" Bore, 2 1/8" Diameter, 63/64" Cutting Length

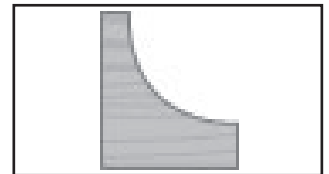

C2016—Double Bead

1/2" Bore, 2 3/16" Diameter, 1" Cutting Height

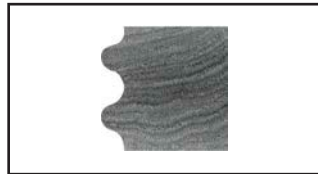
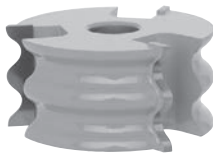

C2014—Glue Joint

1/2" Bore, 2" Diameter, 1" Cutting Length

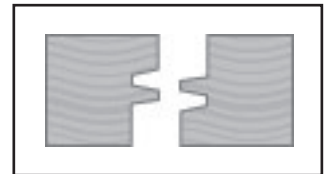
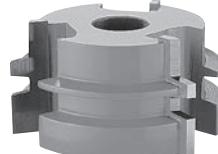

C2012—Drop Leaf Bead

1/2" Bore, 2 1/8" Diameter, 15/16" Cutting Height,
1/2" Radius

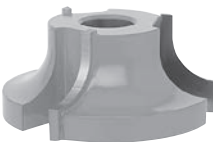

C2015—Screen Mould

1/2" Bore, 2 1/8" Diameter, 1" Cutting Length

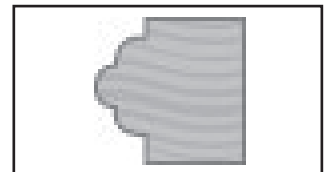
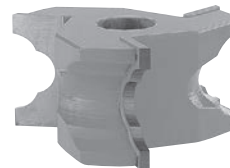

C2018—Cabinet Door Lip

1/2" Bore, 2" Diameter, 1" Cutting Height

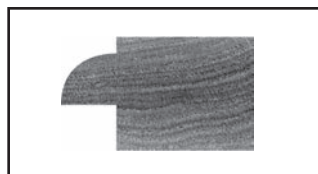
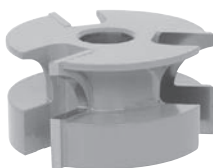

C2017—Cove and Bead

1/2" Bore, 2" Diameter, 1" Cutting Height,
1/4" Radius



order online at www.grizzly.com or call 1-800-523-4777



SECTION 6: MAINTENANCE

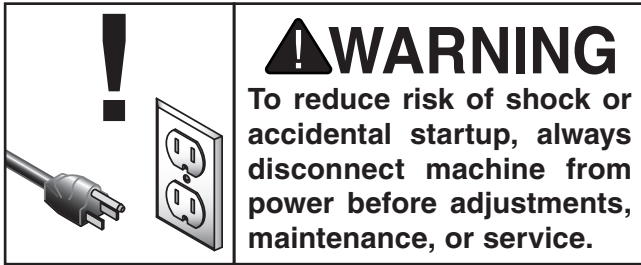

Schedule

For optimum performance from your machine, follow this maintenance schedule and refer to any specific instructions given in this section.

Daily Check

- Loose mounting bolts.
- Worn or damaged cutters.
- Clean/lubricate table and miter gauge.
- Worn or damaged wires.
- Any other unsafe condition.

Weekly Maintenance

- Clean/vacuum dust buildup from in and around cabinet and off motor.

Monthly Check

- Check/lubricate spindle slide and leadscrew (see **Page 42**).
- Check V-belt condition and tension (see **Page 43**).

Annually

- Replace V-belt.

Cleaning & Protecting

Cleaning the Model G1026 is relatively easy. Vacuum excess wood chips and sawdust, and wipe off the remaining dust with a dry cloth. Blow out hard-to-reach areas with compressed air, and keep the spindle clear of wood dust and chips. If any resin has built up, use a resin dissolving cleaner to remove it.

Protect the unpainted cast iron table by wiping it clean after every use—this ensures moisture from wood dust does not remain on bare metal surfaces. Keep the table rust-free with regular applications of products like G96® Gun Treatment, SLIPIT®, or Boeshield® T-9.

G2871—Boeshield® T-9 12 Oz. Spray

G2870—Boeshield® T-9 4 Oz. Spray

Perfect for unpainted cast iron surfaces, this ozone-friendly protective spray penetrates deep and really holds up against corrosive environments. Lubricates metals for months and is also safe for use on most paints, plastics, and vinyls. Developed by Boeing engineers for aircraft applications—this is the best!



Figure 63. Boeshield® T-9 spray.



Lubrication

Since all bearings are sealed and permanently lubricated, simply leave them alone until they need to be replaced. Do not lubricate them. However, the spindle slide and leadscrew do need lubrication.

Items Needed	Qty
Phillips Head Screwdriver #2	1
Mineral Spirits.....	As Needed
Shop Rags.....	As Needed
Stiff Brush.....	1
NLGI#2 Grease	Thin Coat

To lubricate the spindle slide and leadscrew:

1. DISCONNECT MACHINE FROM POWER!
2. Remove the rear cover.
3. Use the spindle height handwheel to lower the spindle all the way, then access the elevation assembly through the rear of the cabinet (see **Figure 64**).

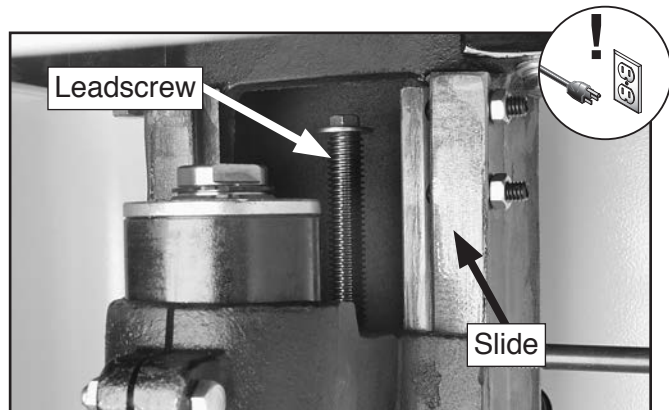

Figure 64. Spindle slide and leadscrew.

4. Use mineral spirits, shop rags, and a stiff brush to clean away grease and built-up grime from the surfaces of both slides and the threads of the leadscrew, then apply a thin coat of multi-purpose grease to these surfaces.
5. Fully raise and lower the spindle to distribute the grease.
6. Re-install the rear cover.

Spindle Bearings

Should a bearing fail, your shaper will develop a noticeable rumble, which will increase when the machine is put under load. If the bad bearing is not replaced, it will eventually seize—possibly doing damage to other parts of the machine. Bearings are standard sizes and can be replaced through Grizzly.

Tools Needed	Qty
Open-End Wrench or Socket 14mm	1
Phillips Head Screwdriver #2	1

To replace the spindle bearings:

1. DISCONNECT MACHINE FROM POWER!
2. Remove the rear cover.
3. Remove the V-Belt (refer to **V-Belt Tension & Replacement** on **Page 43**).
4. Loosen the hex bolt on the spindle cartridge bracket (see **Figure 65**).

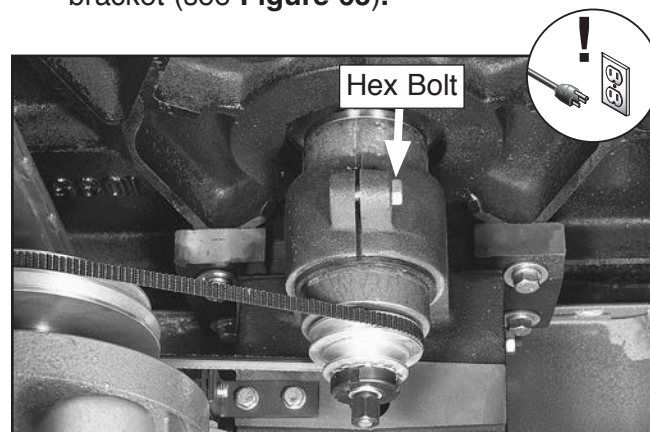

Figure 65. Bolt on spindle slide.

5. The bearing housing will drop down. If you need to spread the spindle slide casting more, use a flat head screwdriver.

⚠ CAUTION

Carefully spread the casting to reduce the risk of the bearing housing falling and pinching fingers. To reduce damage, place a pad underneath the housing. The casting will break if too much pressure is applied.



6. Remove the spindle and replace the bearings inside the bearing housing. If you need pointers regarding bearing replacement, call Technical Support.
7. To slide the housing back in, reverse the procedure. Make sure the hex bolt is tightened securely.
8. Re-install the rear cover.

4. To tension the V-belt, slide the motor to the left until the V-belt is snug, then tighten the bolts. The amount of V-belt deflection between the pulleys should be approximately 1/4" when moderate pressure is applied, as shown in **Figure 67**.

V-Belt Tension & Replacement

The V-belt transfers power from the motor to the spindle. If the V-belt does not have the proper tension or is damaged in any way, the shaper will not operate optimally, and unnecessary wear on the moving parts will occur. Regularly check the V-belt tension and replace it when necessary.

Tools Needed	Qty
Open-End Wrench or Socket 19mm	1

To tension the V-belt:

1. DISCONNECT MACHINE FROM POWER!
2. Remove the rear cover.
3. Loosen the two hex bolts holding the motor mount to the spindle slide (see **Figure 66**). Do not remove the bolts completely.

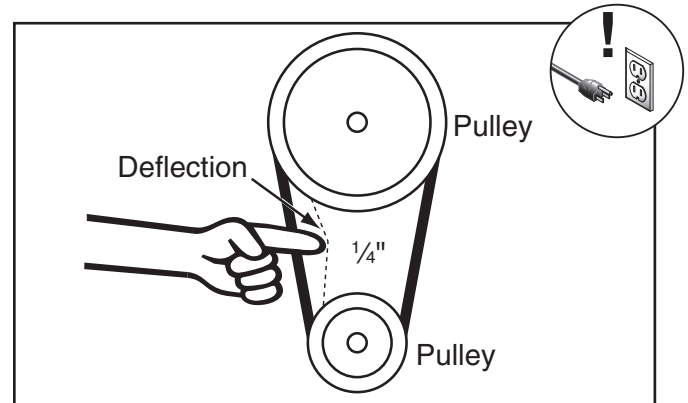

Figure 67. Checking V-belt tension.

5. When the V-belt is adjusted properly, tighten the motor mount hex bolts.
6. Check to make sure the V-belt is correctly aligned on both pulleys (refer to **Pulley Alignment** on **Page 48** for detailed instructions).
7. Re-install the rear cover.



Figure 66. Location of motor mount hex bolts.

— If the V-belt is cracked, excessively worn, or damaged, slide the motor to the right, then replace the V-belt.



SECTION 7: SERVICE

Review the troubleshooting procedures in this section if a problem develops with your machine. If you need replacement parts or additional help with a procedure, call our Technical Support. **Note:** *Please gather the serial number and manufacture date of your machine before calling.*

Troubleshooting

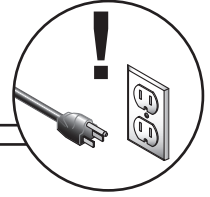

Motor & Electrical

Symptom	Possible Cause	Possible Solution
Machine does not start or a breaker trips.	<ol style="list-style-type: none"> 1. Switch disabling lock installed. 2. Power supply switched OFF or at fault. 3. Plug/receptacle at fault/wired wrong. 4. Motor connection wired wrong. 5. Wall circuit breaker tripped. 6. Wiring open/has high resistance. 7. Start capacitor at fault. 8. Spindle switch at fault. 9. Motor at fault. 	<ol style="list-style-type: none"> 1. Remove switch disabling lock. 2. Ensure power supply is ON/has correct voltage. 3. Test for good contacts; correct the wiring. 4. Correct motor wiring connections (Page 52). 5. Ensure circuit size is correct/replace weak breaker. 6. Check/fix broken, disconnected, or corroded wires. 7. Test/replace if faulty. 8. Replace switch. 9. Test/repair/replace.
Machine stalls or is underpowered.	<ol style="list-style-type: none"> 1. Workpiece material not suitable for machine. 2. Fence/jig loose or misaligned. 3. V-belt slipping. 4. Motor wired incorrectly. 5. Plug/receptacle at fault. 6. Pulley slipping on shaft. 7. Motor bearings at fault. 8. Machine undersized for task. 9. Motor overheated. 10. Spindle switch at fault. 11. Motor at fault. 	<ol style="list-style-type: none"> 1. Only cut wood/ensure moisture is below 20% (Page 28). 2. Adjust fence/jig (Page 31). 3. Tension/replace V-belt (Page 43). 4. Wire motor correctly (Page 52). 5. Test for good contacts/correct wiring. 6. Replace loose pulley/shaft. 7. Test/repair/replace. 8. Use correct, sharp cutter; reduce feed rate/depth of cut. 9. Clean motor, let cool, and reduce workload. 10. Test/replace switch. 11. Test/repair/replace.
Machine has vibration or noisy operation.	<ol style="list-style-type: none"> 1. Motor or component loose. 2. Cutter at fault. 3. V-belt worn or loose. 4. Spindle at fault. 5. Pulley loose. 6. Motor mount loose/broken. 7. Machine incorrectly mounted. 8. Motor fan rubbing on fan cover. 9. Motor bearings at fault. 	<ol style="list-style-type: none"> 1. Inspect/replace damaged bolts/nuts, and re-tighten. 2. Replace damaged cutter. 3. Tension/replace V-belt (Page 43). 4. Tighten loose spindle; replace defective spindle or spindle cartridge. 5. Re-align/replace shaft, pulley, set screw, and key. 6. Tighten/replace. 7. Tighten mounting bolts; relocate/shim machine. 8. Fix/replace fan cover; replace loose/damaged fan. 9. Test by rotating shaft; rotational grinding/loose shaft requires bearing replacement.



Symptom	Possible Cause	Possible Solution
Workpiece is burned when cut.	<ol style="list-style-type: none"> 1. Dull cutter. 2. Too slow of a feed rate. 3. Pitch build-up on cutter. 4. Cutter rotating in the wrong direction. 5. Taking too deep of a cut. 	<ol style="list-style-type: none"> 1. Replace cutter or have it professionally sharpened. 2. Increase feed speed. 3. Clean cutter with a blade and bit cleaning solution. 4. Reverse the direction of the cutter rotation. 5. Make several passes of light cuts.
Fuzzy grain.	<ol style="list-style-type: none"> 1. Wood may have high moisture content or surface wetness. 2. Dull cutter. 	<ol style="list-style-type: none"> 1. Check moisture content and allow to dry if moisture is more than 20% (Page 28). 2. Replace or have cutter professionally sharpened.
Chipping.	<ol style="list-style-type: none"> 1. Knots or conflicting grain direction in wood. 2. Nicked or chipped cutter. 3. Feeding workpiece too fast. 4. Taking too deep of a cut. 5. Cutting against the grain of the wood. 	<ol style="list-style-type: none"> 1. Inspect workpiece for knots and grain direction; only use clean stock. 2. Replace the cutter, or have it professionally sharpened. 3. Slow down the feed rate. 4. Take a smaller depth of cut. (Always reduce cutting depth when working with hard woods.) 5. Cut with the grain of the wood.
Divots in the edge of the cut.	<ol style="list-style-type: none"> 1. Inconsistent feed speed. 2. Inconsistent pressure against the fence and rub collar. 3. Fence not adjusted correctly. 	<ol style="list-style-type: none"> 1. Move smoothly or use a power feeder. 2. Apply constant pressure. 3. Adjust fence.



Table Insert Adjustment

The aluminum table insert is held in place by a cast-iron insert ring, which should be adjusted level with the table top. This is necessary to avoid the workpiece catching on the insert or ring during operation, causing an unsafe condition and poor cutting results.

Tools Needed	Qty
Phillips Screwdriver #2	1
Standard Screwdriver #2	1
Precision Straightedge	1

To make the insert and insert ring level with the table top:

1. DISCONNECT MACHINE FROM POWER!
2. Remove the table insert, then remove the three Phillips screws that secure the insert ring to the table top.

Note: Notice that there is a barrel screw underneath each of the Phillips screws (see **Figure 68**).



Figure 68. Insert ring barrel screw.

3. Lay a precision straightedge across the insert ring and the table, then adjust the barrel screws until the insert ring is level with the table top in all directions (see **Figure 69**).

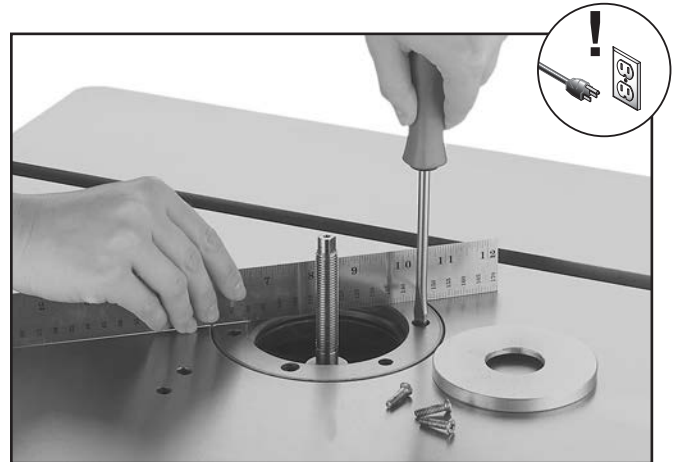

Figure 69. Leveling the insert ring.

4. Replace the Phillips screws, but do not over-tighten them.
5. Replace the table insert, then use the straight-edge to re-check the inserts. If necessary, repeat this procedure until both the insert ring and table insert are completely level with the table top in all directions.



Fence Board Alignment

For safe and accurate shaping, the fence boards must be parallel with one another so that they properly support the workpiece through the entire cutting operation.

Tools Needed	Qty
Phillips Screwdriver #2	1
Precision Straightedge 24"	1
Shims.....	As Needed

To make the fence boards parallel:

1. DISCONNECT MACHINE FROM POWER!
2. Make sure the fence boards are even with each other, then place the straightedge against both fence boards, as shown in **Figure 70**.

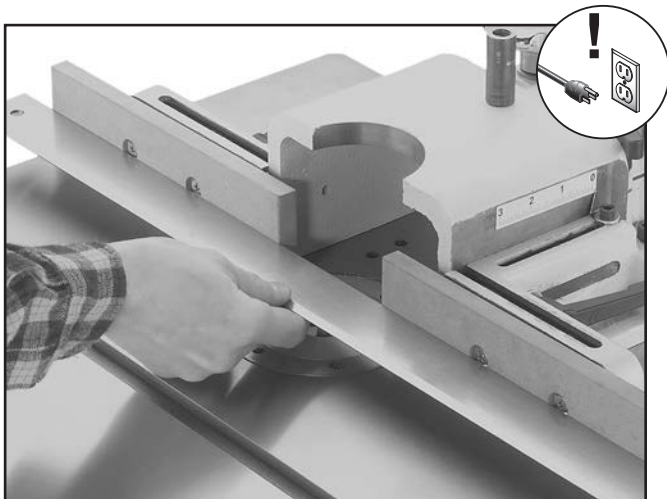

Figure 70. Example of aligning fence boards.

- If there is a gap between the straight-edge and the fence boards, use shims as needed between the fence boards and the mounting brackets to make the boards completely parallel with each other along their entire length.

Truing Fence

A flat and properly aligned fence creates a safer, smoother cutting operation. A damaged or worn fence should be replaced. Be sure to replace BOTH fences at the same time to ensure each is properly flattened and aligned correctly.

To align fences:

1. Ensure bolts through wood fence facing on each side are tight and adequately countersunk.
2. To align fence faces, rotate fence offset knob so they are in alignment. Micro-adjust and check alignment with a straightedge.
3. If fences are not coplanar with each other, remove both fences and resurface as one unit. You can perform this operation on a jointer as shown in **Figure 71**.

NOTICE

Make sure screws are countersunk deep enough so workpiece will not come in contact with heads of screws! Check screw depth after each pass to ensure that screws will not contact knives!

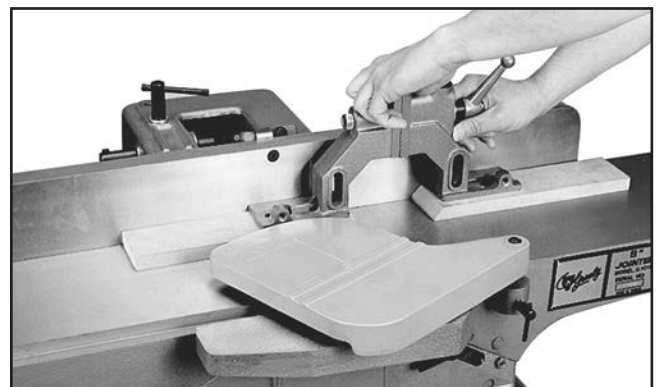

Figure 71. Example of resurfacing fences on a jointer.



Pulley Alignment

Pulley alignment is important to the performance of your shaper. If the pulleys are just slightly out of alignment, the shaper may suffer from power loss and decreased V-belt life. When the pulleys are parallel and aligned with each other, they are said to be coplanar—in the same plane.

Checking Pulley Coplanarity

Tools Needed	Qty
Precision Straightedge	1

To check the alignment of the pulleys:

1. DISCONNECT MACHINE FROM POWER!
2. Remove the rear cover.
3. Hold the straightedge up to the pulleys to determine if they are both aligned and parallel, as shown in **Figure 72**.



Figure 72. Checking pulley alignment.

— If the pulleys are not parallel or aligned with each other, perform the appropriate steps in the following procedures.

Adjusting Pulleys Parallel

Tools Needed	Qty
Precision Straightedge	1
Phillips Screwdriver #2	1
Open-End Wrench or Socket 12mm	1
Open-End Wrench or Socket 14mm	1

To make the pulleys parallel:

1. DISCONNECT MACHINE FROM POWER!
2. Remove the motor cover from the cabinet, then loosen the four motor mounting hex bolts that are behind the motor mount (see **Figure 73**).

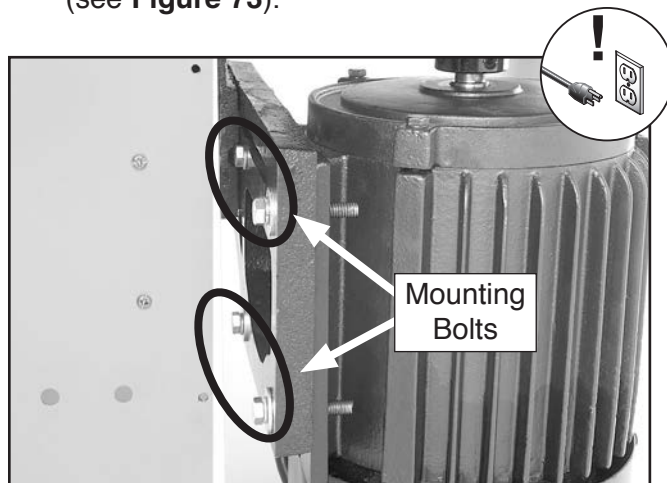

Figure 73. Motor mounting bolts location.

3. Reach into the rear of the cabinet and loosen the two motor mount hex bolts directly under the spindle cartridge (see **Figure 74**).



Figure 74. Location of motor mount hex bolts.

4. Using the straightedge as a guide, rotate the motor assembly until the motor pulley is parallel with the spindle pulley, then re-tighten the four motor mount hex bolts and re-tighten the two motor mount hex bolts under the spindle cartridge.



Aligning Pulleys

Tools Needed	Qty
Precision Straightedge	1
Open-End Wrench or Socket 14mm	1

To align the pulleys:

1. DISCONNECT MACHINE FROM POWER!
2. Reach into the rear of the cabinet, then loosen the hex bolt on the spindle cartridge bracket, as shown in **Figure 75**.

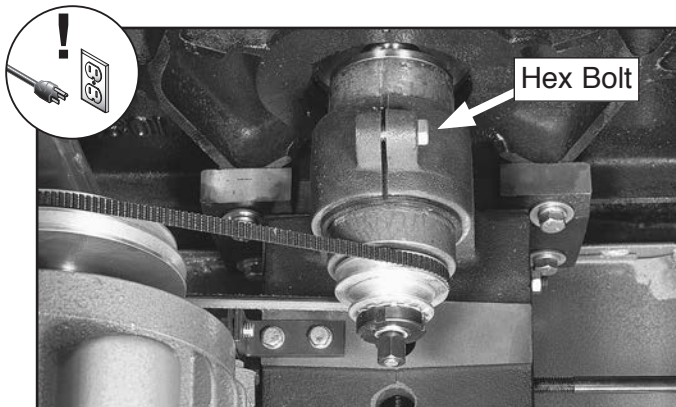

Figure 75. Location of spindle cartridge bracket hex bolt.

3. Using the straightedge as a guide, adjust the height of the spindle cartridge until the pulleys are aligned, then re-tighten the hex bolt.

Tip: You can also loosen the two set screws on the motor pulley, raise or lower the motor pulley so it is aligned with the spindle pulley, then tighten the set screws.

4. Replace the motor cover and rear cover before reconnecting the machine to power.

Gib Adjustment

The gib controls the smoothness of the slide movement, as well as the run out or end play of the spindle. Tightening the gibs too much will make it hard to adjust the height of the spindle and cause excessive wear on the slide. Loosening the gibs too much will introduce spindle end play and cause poor cutting results and excessive wear on the spindle bearings.

Checking Gib Adjustment

1. DISCONNECT MACHINE FROM POWER!
2. Use the spindle height handwheel to raise the spindle to its highest position.
 - If it is difficult to turn the handwheel or you feel resistance from the spindle slide, the gibs may need to be loosened.
3. Use the spindle height lock to hold the spindle in place, then attempt to wiggle the top of the spindle. If there is movement, the gibs may need to be tightened.



Adjusting the Gibs

Tools Needed	Qty
Open-End Wrench 12mm.....	1
Hex Wrench 4mm.....	1

To adjust the gibs:

1. DISCONNECT MACHINE FROM POWER!
2. Loosen the jam nuts on the gib adjustment set screws (see **Figure 76**).

3. Evenly adjust the set screws small amounts, then test the results.
4. When you are satisfied with the gib adjustment, re-tighten the jam nuts without turning the set screws.
5. Re-check the gib adjustment. If necessary, repeat this procedure.

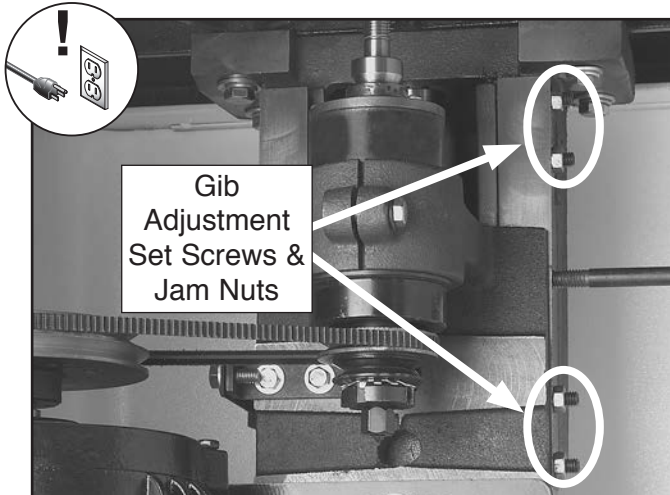

Figure 76. Location of set screws and jam nuts for adjusting gibs.



SECTION 8: WIRING

These pages are current at the time of printing. However, in the spirit of improvement, we may make changes to the electrical systems of future machines. Compare the manufacture date of your machine to the one stated in this manual, and study this section carefully.

If there are differences between your machine and what is shown in this section, call Technical Support at (570) 546-9663 for assistance BEFORE making any changes to the wiring on your machine. An updated wiring diagram may be available. **Note:** Please gather the serial number and manufacture date of your machine before calling. This information can be found on the main machine label.

WARNING

Wiring Safety Instructions

SHOCK HAZARD. Working on wiring that is connected to a power source is extremely dangerous. Touching electrified parts will result in personal injury including but not limited to severe burns, electrocution, or death. Disconnect the power from the machine before servicing electrical components!

MODIFICATIONS. Modifying the wiring beyond what is shown in the diagram may lead to unpredictable results, including serious injury or fire. This includes the installation of unapproved after-market parts.

WIRE CONNECTIONS. All connections must be tight to prevent wires from loosening during machine operation. Double-check all wires disconnected or connected during any wiring task to ensure tight connections.

CIRCUIT REQUIREMENTS. You MUST follow the requirements at the beginning of this manual when connecting your machine to a power source.

WIRE/COMPONENT DAMAGE. Damaged wires or components increase the risk of serious personal injury, fire, or machine damage. If you notice that any wires or components are damaged while performing a wiring task, replace those wires or components.

MOTOR WIRING. The motor wiring shown in these diagrams is current at the time of printing but may not match your machine. If you find this to be the case, use the wiring diagram inside the motor junction box.













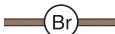

CAPACITORS/INVERTERS. Some capacitors and power inverters store an electrical charge for up to 10 minutes after being disconnected from the power source. To reduce the risk of being shocked, wait at least this long before working on capacitors.

EXPERIENCING DIFFICULTIES. If you are experiencing difficulties understanding the information included in this section, contact our Technical Support at (570) 546-9663.

NOTICE

The photos and diagrams included in this section are best viewed in color. You can view these pages in color at www.grizzly.com.

COLOR KEY

BLACK 	BLUE 	YELLOW 	LIGHT BLUE 
WHITE 	BROWN 	YELLOW GREEN 	BLUE WHITE 
GREEN 	GRAY 	PURPLE 	TURQUOISE 
RED 	ORANGE 	PINK 	



Wiring Diagram

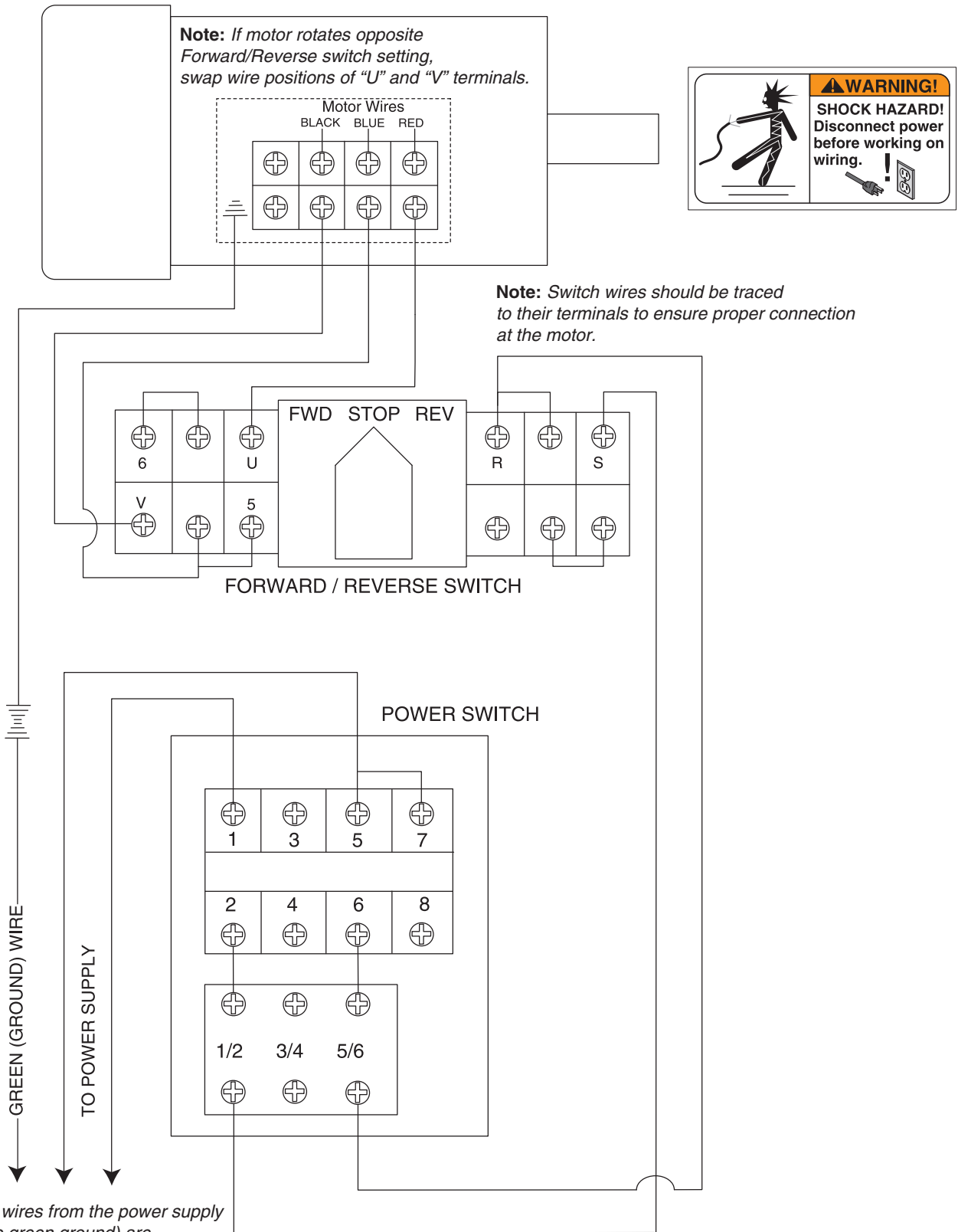

SECTION 9: PARTS

We do our best to stock replacement parts when possible, but we cannot guarantee that all parts shown are available for purchase. Call (800) 523-4777 or visit www.grizzly.com/parts to check for availability.

Stand & Table

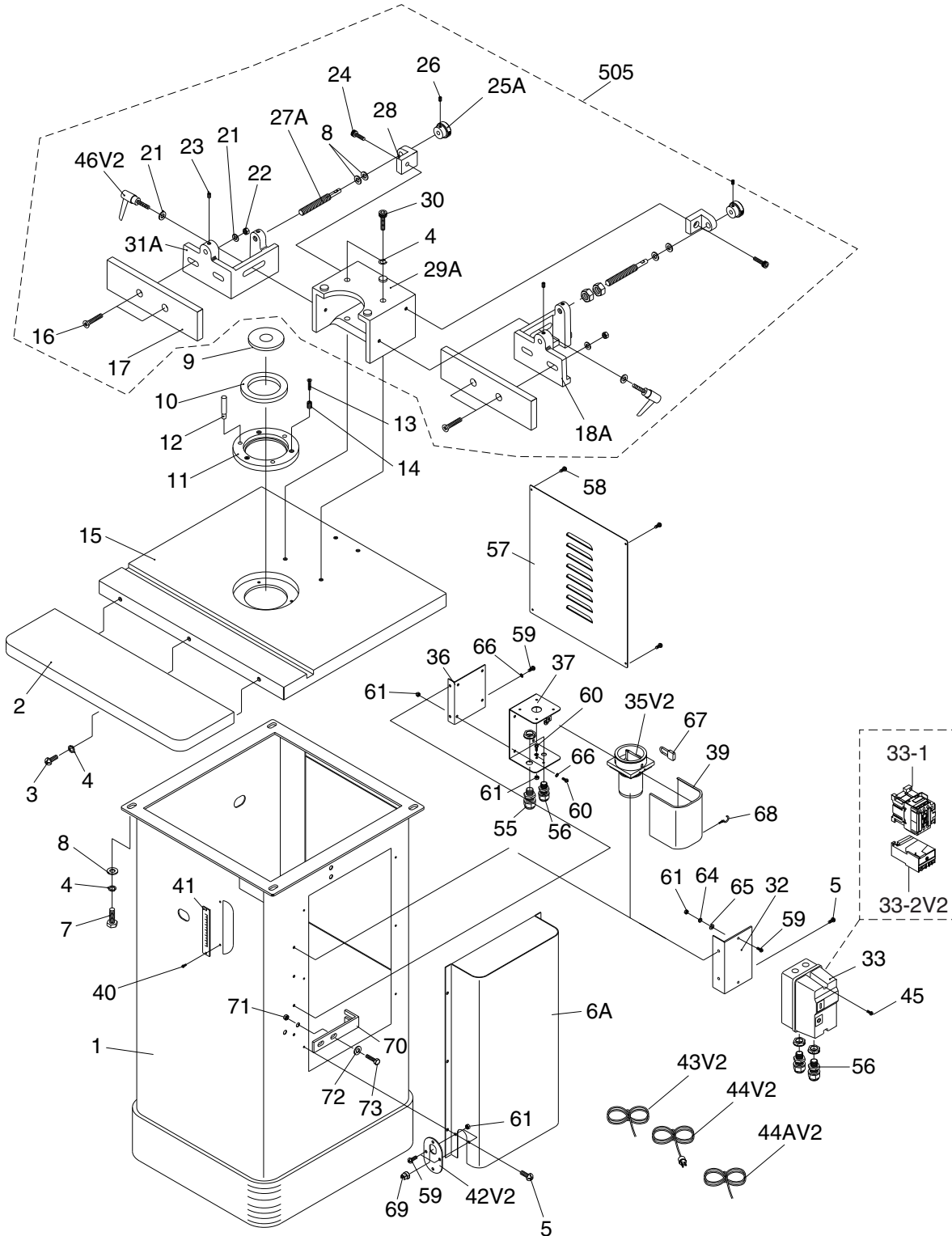

Stand & Table Parts List

REF	PART #	DESCRIPTION
1	P1026001	STAND BODY
2	P1026002	EXTENSION WING
3	P1026003	HEX BOLT 3/8-16 X 1
4	P1026004	LOCK WASHER 3/8
5	P1026005	PHLP HD SCR 1/4-20 X 3/8
6A	P1026006A	STAND SIDE COVER V2.01.06
7	P1026007	HEX BOLT 3/8-16 X 3/4
8	P1026008	FLAT WASHER 3/8
9	P1026009	TABLE INSERT 1-1/2" ID
10	P1026010	TABLE INSERT 2-15/16" ID
11	P1026011	TABLE INSERT RING 4-1/4" ID
12	P1026012	STARTING PIN
13	P1026013	FLAT HD SCR 10-24 X 1
14	P1026014	BARREL SCREW 7/16-14 X 1/2
15	P1026015	TABLE
16	P1026016	FLAT HD SCR 5/16-18 X 1-1/2
17	P1026017	FENCE BOARD
18A	P1026018A	FENCE MOUNT (RH) V2.12.95
21	P1026021	FENDER WASHER 5/16
22	P1026022	HEX NUT 5/16-18
23	P1026023	SET SCREW 5/16-18 X 3/8
24	P1026024	CAP SCREW 5/16-18 X 3/4
25A	P1026025A	KNURLED KNOB 8MM D32
26	P1026026	SET SCREW 5/16-18 X 1/4
27A	P1026027A	FENCE ADJ SCREW 1/2-13 X 4-1/4 V2.12.95
28	P1026028	ADJUST SCREW BRACKET
29A	P1026029A	MAIN FENCE HOUSING V2.02.06
30	P1026030	CAP SCREW 3/8-16 X 1
31A	P1026031A	FENCE MOUNT (LH) V2.12.95
32	P1026032	MAGNETIC SWITCH MOUNT BRACKET
33	P1026033	MAGNETIC SWITCH 3HP 1PH
33-1	P1026033-1	CONTACTOR SDE MA-15 220V

REF	PART #	DESCRIPTION
33-2V2	P1026033-2V2	OL RELAY SDE RA-20 12-18A V2.11.12
35V2	P1026035V2	FWD/REV SWITCH V2.04.10
36	P1026036	SWITCH MOUNT BRACKET
37	P1026037	SWITCH BOX
39	P1026039	SWITCH BOX COVER V1.10.95
40	P1026040	TAP SCREW #6 X 1/2
41	P1026041	SPINDLE HEIGHT SCALE
42V2	P1026042V2	CORD GROMMET V2.04.10
43V2	P1026043V2	MOTOR CORD 14G 4C 30" V2.04.10
44AV2	P1026044AV2	SWITCH CORD 14AWG 3C 27" V2.04.10
44V2	P1026044V2	POWER CORD 14G 3C 76" 6-15 V2.04.10
45	P1026045	WHITE SWITCH COVER SCREW V1.12.95
46V2	P1026046V2	ADJUSTABLE HANDLE 5/16-18 V2.02.06
55	P1026055	STRAIN RELIEF M16 TYPE-6 ST
56	P1026056	STRAIN RELIEF M16 TYPE-1 SNAP-IN
57	P1026057	REAR STAND PANEL
58	P1026058	FLANGE SCREW 10-24 X 3/8
59	P1026059	PHLP HD SCR 10-24 X 1/2
60	P1026060	PHLP HD SCR 10-24 X 3/8
61	P1026061	HEX NUT 10-24
64	P1026064	LOCK WASHER #10
65	P1026065	FLAT WASHER #10
66	P1026066	EXT TOOTH WASHER #10
67	P1026067	SWITCH PADLOCK
68	P1026068	PADLOCK STORAGE HOOK
69	P1026069	STRAIN RELIEF M16 TYPE-6 ST
70	P1026070	MOTOR SHIPPING BRACE
71	P1026071	HEX NUT 5/16-18
72	P1026072	FLAT WASHER 5/16
73	P1026073	HEX BOLT 5/16-18 X 3/4
505	P1026505	COMPLETE FENCE ASSY



Motor & Handwheel

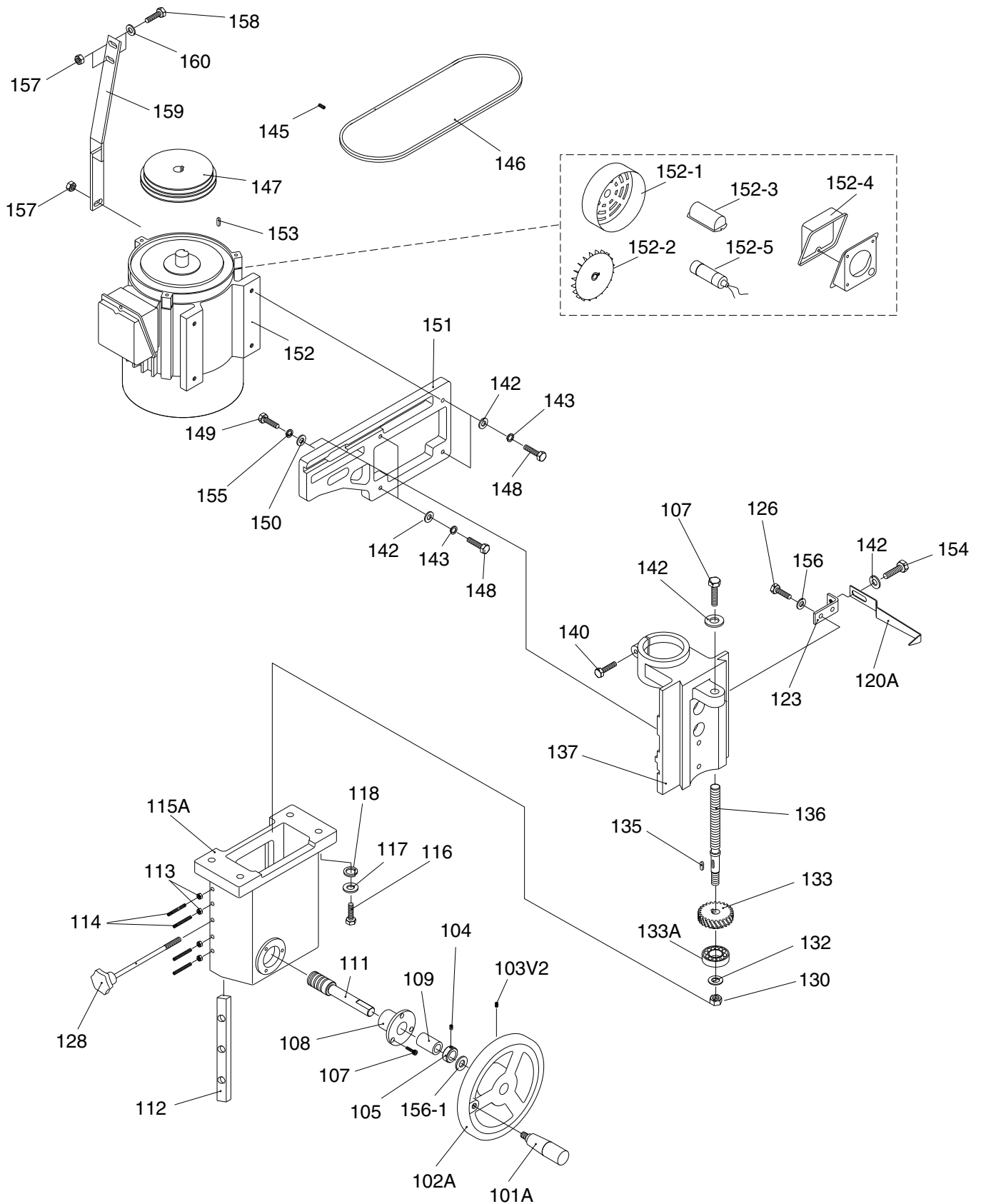

Motor & Handwheel Parts List

REF	PART #	DESCRIPTION
101A	P1026101A	HANDWHEEL HANDLE V2.01.06
102A	P1026102A	HANDWHEEL V2.01.06
103V2	P1026103V2	SET SCREW 3/8-16 X 3/8
104	P1026104	SET SCREW 5/16-18 X 5/16
105	P1026105	LOCK COLLAR
107	P1026107	HEX BOLT 5/16-18 X 3/4
108	P1026108	SHAFT MOUNT
109	P1026109	BUSHING 24 X 19 X 24
111	P1026111	WORM SHAFT
112	P1026112	GIB
113	P1026113	HEX NUT 5/16-18
114	P1026114	SET SCREW 5/16-18 X 1-3/8
115A	P1026115A	ELEVATION HOUSING GREEN V2.10.98
116	P1026116	HEX BOLT 1/2-13 X 1-3/4
117	P1026117	FLAT WASHER 1/2
118	P1026118	LOCK WASHER 1/2
120A	P1026120A	POINTER V2.02.98
123	P1026123	POINTER MOUNT
126	P1026126	HEX BOLT 1/4-20 X 1/2
128	P1026128	LOCK KNOB BOLT
130	P1026130	LOCK NUT 5/8-11
132	P1026132	BEARING FLAT WASHER 5/8
133	P1026133	ELEVATION BEVEL GEAR
133A	P1026133A	THRUST BEARING 51103
135	P1026135	KEY 5 X 5 X 18
136	P1026136	ELEVATION LEADSCREW 3/4 X 7-1/2

REF	PART #	DESCRIPTION
137	P1026137	SPINDLE BRACKET
140	P1026140	HEX BOLT 3/8-16 X 1-1/2
142	P1026142	FLAT WASHER 5/16
143	P1026143	LOCK WASHER 5/16
145	P1026145	SET SCREW 5/16-24 X 5/8
146	P1026146	V-BELT 7 X 690
147	P1026147	MOTOR PULLEY
148	P1026148	HEX BOLT 5/16-18 X 1
149	P1026149	HEX BOLT 1/2-13 X 1-3/4
150	P1026150	FLAT WASHER 1/2
151	P1026151	MOTOR MOUNT PLATE
152	P1026152	MOTOR 3HP 220V 1-PH
152-1	P1026152-1	MOTOR FAN COVER
152-2	P1026152-2	MOTOR FAN
152-3	P1026152-3	CAPACITOR COVER
152-4	P1026152-4	MOTOR JUNCTION BOX
152-5	P1026152-5	S CAPACITOR 400M 125V 1-3/4 X 3-3/8
153	P1026153	KEY 5 X 5 X 30
154	P1026154	HEX BOLT 5/16-18 X 3/8
155	P1026155	LOCK WASHER 1/2
156	P1026156	FLAT WASHER 1/4
156-1	P1026156-1	HANDWHEEL WASHER
157	P1026157	HEX NUT 5/16-18
158	P1026158	HEX BOLT 5/16-18 X 3/4
159	P1026159	TOP MOTOR SHIPPING BRACE
160	P1026160	FLAT WASHER 5/16



Spindle

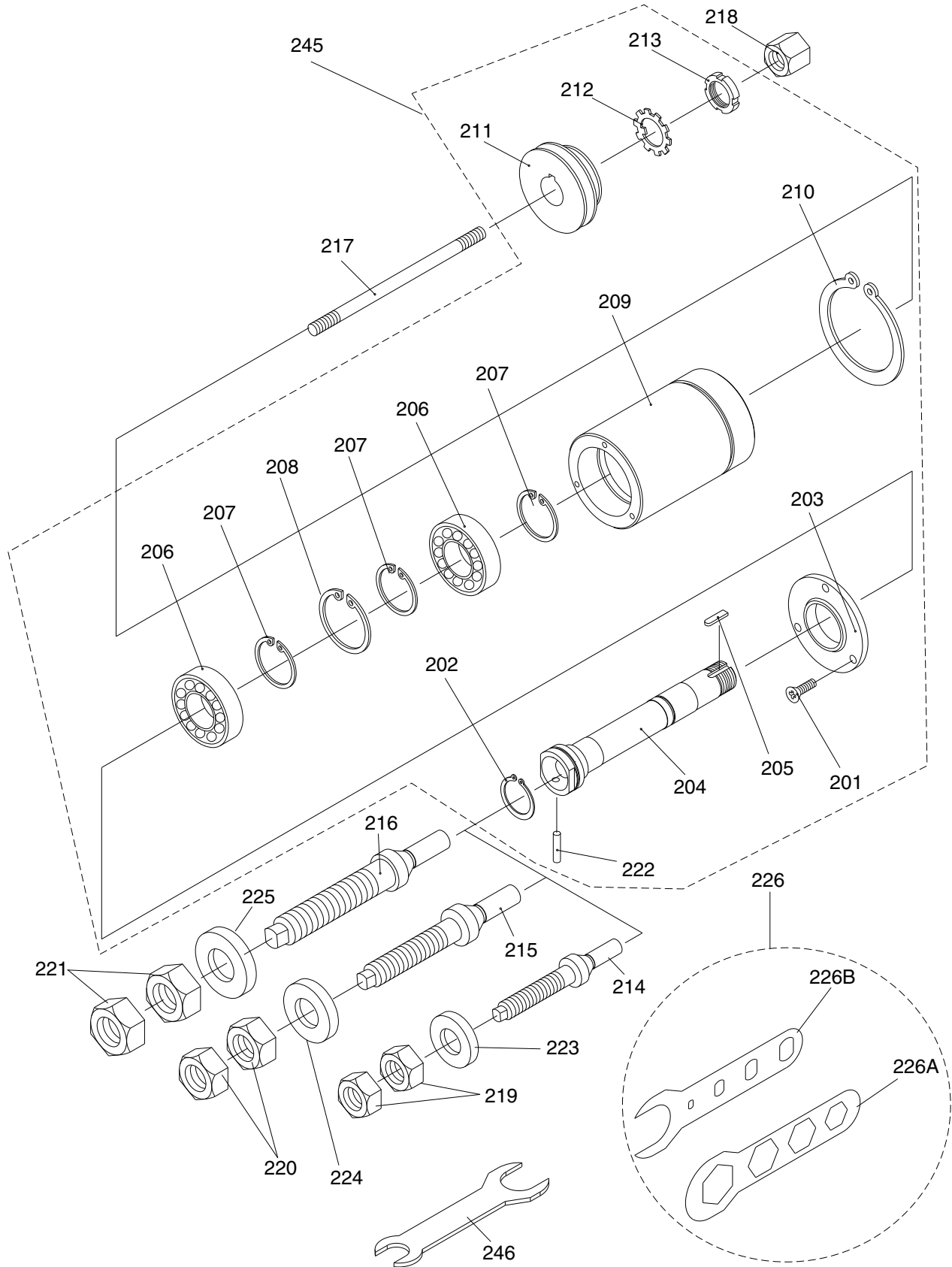

Spindle Parts List

REF	PART #	DESCRIPTION
201	P1026201	PHLP HD SCR 10-24 X 1/2
202	P1026202	EXT RETAINING RING 35MM
203	P1026203	QUILL FLANGE
204	P1026204	SPINDLE CARTRIDGE
205	P1026205	KEY 5 X 5 X 15
206	P1026206	BALL BEARING 6205ZZ
207	P1026207	INT RETAINING RING 25MM
208	P1026208	INT RETAINING RING 52MM
209	P1026209	SPINDLE HOUSING
210	P1026210	EXT RETAINING RING 70MM
211	P1026211	SPINDLE PULLEY
212	P1026212	TOOTHED WASHER 3/4" LARGE
213	P1026213	SPANNER NUT 3/4-10
214	P1026214	SPINDLE 1/2"
215	P1026215	SPINDLE 3/4"

REF	PART #	DESCRIPTION
216	P1026216	SPINDLE 1"
217	P1026217	DRAWBAR 3/8-24 X 7-3/4
218	P1026218	DRAWBAR NUT 3/8-24
219	P1026219	SPINDLE NUT 1/2" 2PC SET
220	P1026220	SPINDLE NUT 3/4" 2PC SET
221	P1026221	SPINDLE NUT 1"-8 2PC SET
222	P1026222	PIN
223	P1026223	SPINDLE WASHER 1/2 X 26 X 3
224	P1026224	SPINDLE WASHER 3/4 X 32 X 3
225	P1026225	SPINDLE WASHER 1 X 38 X 3
226	P1026226	SPINDLE WRENCH SET
226A	P1026226A	SPINDLE WRENCH HEXAGONAL
226B	P1026226B	SPINDLE WRENCH RECTANGULAR
246	P1026246	COMBO WRENCH 7/8" X 1-1/4"

Spacers

Bore	Diameter	Height	Replacement Part #
1/2"	1"	1/4"	W1159
1/2"	1"	3/8"	W1160
1/2"	1"	1/2"	W1161
1/2"	1"	3/4"	W1162
3/4"	1-1/4"	1/4"	W1164
3/4"	1-1/4"	3/8"	W1165
3/4"	1-1/4"	1/2"	W1166
3/4"	1-1/4"	3/4"	W1167
1"	1-1/2"	1/4"	W1168
1"	1-1/2"	3/8"	W1170
1"	1-1/2"	1/2"	W1171
1"	1-1/2"	3/4"	W1172
1"	1-1/2"	1"	W1173
1-1/4"	1-3/4"	1/4"	W1174
1-1/4"	1-3/4"	3/8"	W1175
1-1/4"	1-3/4"	1/2"	W1176
1-1/4"	1-3/4"	3/4"	W1177
1-1/4"	1-3/4"	1"	W1178



Safety Guard

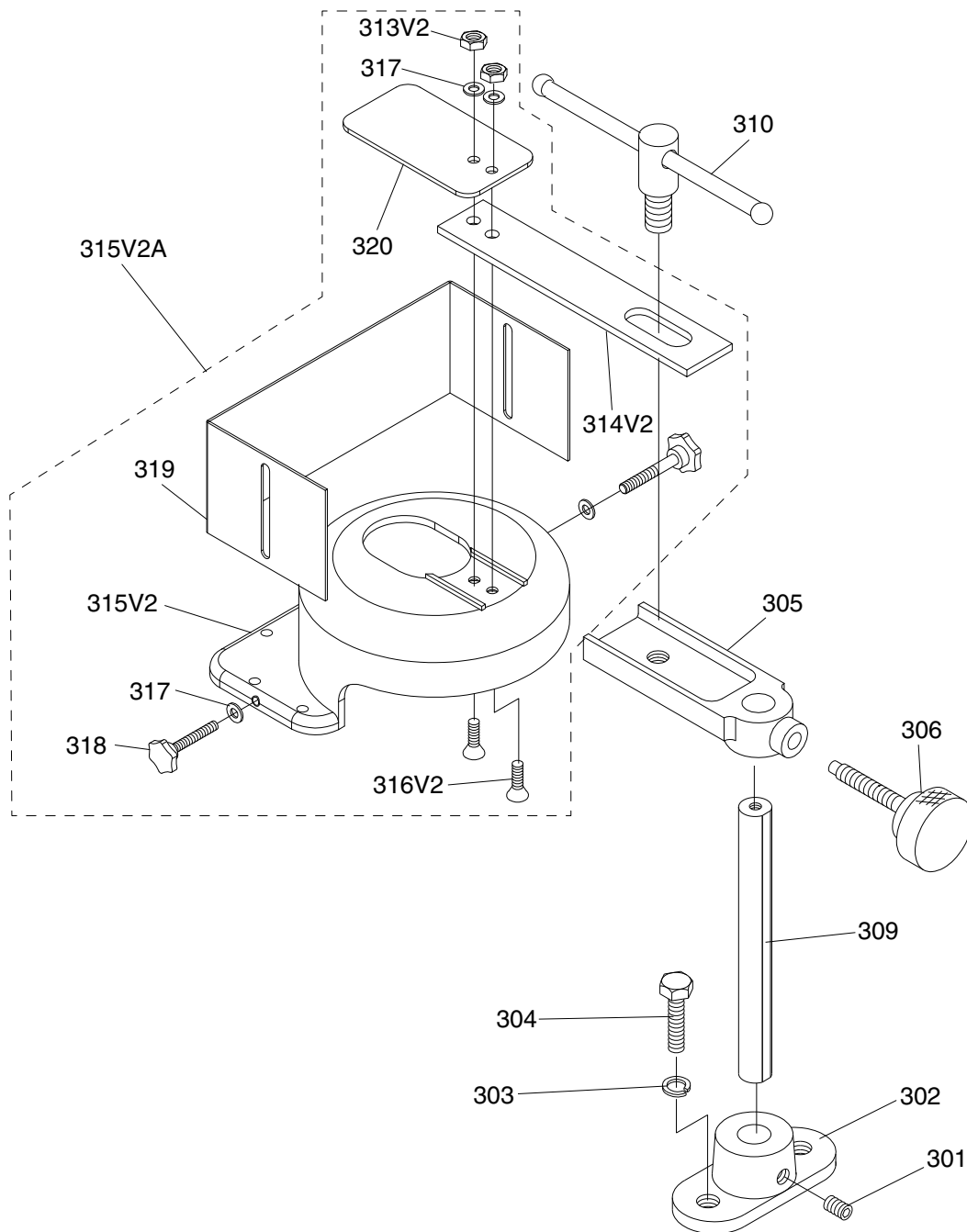

REF	PART #	DESCRIPTION
301	P1026301	SET SCREW 5/16-18 X 3/8
302	P1026302	SHAFT MOUNT
303	P1026303	LOCK WASHER 3/8
304	P1026304	HEX BOLT 3/8-16 X 3/4
305	P1026305	EXTENSION BRACKET
306	P1026306	LOCK KNOB BOLT
309	P1026309	SHAFT
310	P1026310	LOCK HANDLE
313V2	P1026313V2	HEX NUT 1/4-20

REF	PART #	DESCRIPTION
314V2	P1026314V2	EXTENSION BAR V2.08.13
315V2	P1026315V2	OVERHEAD GUARD CASTING V2.08.13
315V2A	P1026315V2A	SAFETY GUARD ASSEMBLY V2.08.13
316V2	P1026316V2	FLAT HD SCR 1/4-20 X 1
317	P1026317	FLAT WASHER 1/4
318	P1026318	KNOB BOLT 1/4-20 X 3/8
319	P1026319	FRONT SAFETY GUARD (STEEL)
320	P1026320	TOP SAFETY GUARD (PLASTIC)



Fence

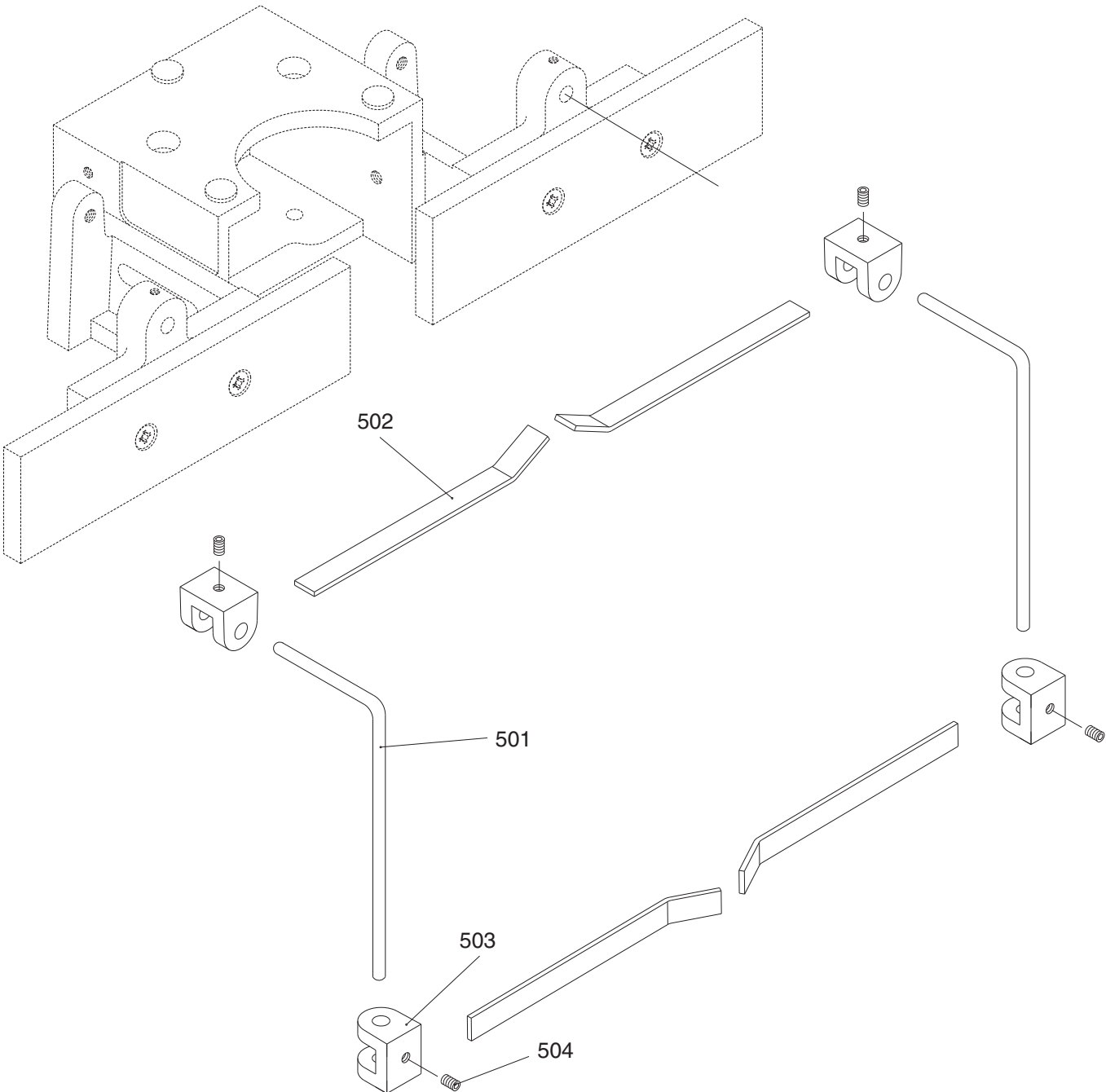

REF	PART #	DESCRIPTION
501	P1026501	HOLD-DOWN BAR
502	P1026502	HOLD-DOWN

REF	PART #	DESCRIPTION
503	P1026503	HOLD-DOWN BRACKET
504	P1026504	SET SCREW 5/16-18 X 3/8



Miter Gauge

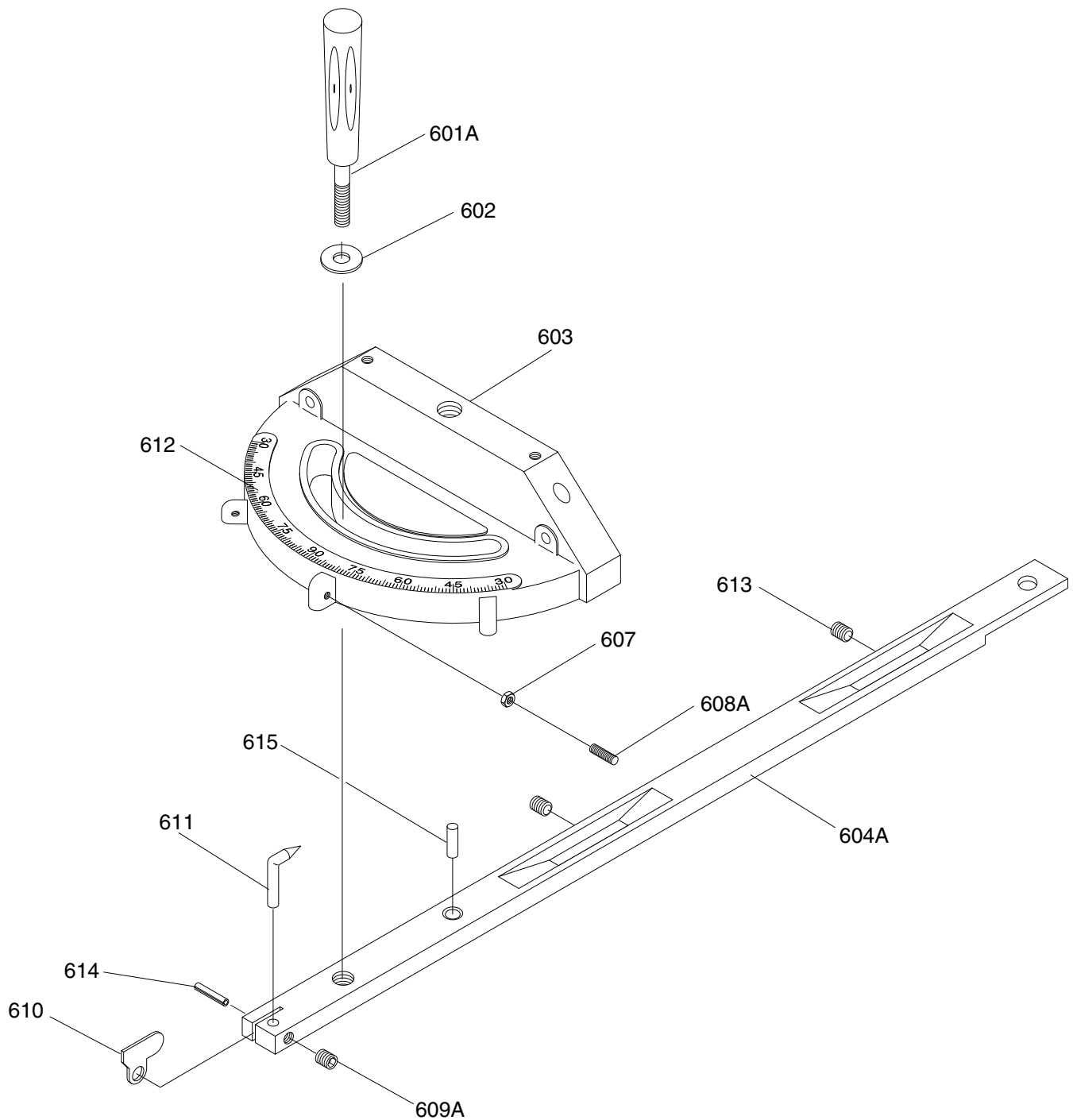

REF	PART #	DESCRIPTION
601A	P1026601A	KNOB V1.11.96
602	P1026602	FLAT WASHER 1/4
603	P1026603	MITER GAUGE BODY V2.05.07
604A	P1026604A	ADJUSTABLE MITER BAR
607	P1026607	HEX NUT 10-24
608A	P1026608A	SET SCREW 10-24 X 3/4
609A	P1026609A	SET SCREW 10-24 X 1/4

REF	PART #	DESCRIPTION
610	P1026610	MITER GAUGE STOP
611	P1026611	POINTER
612	P1026612	MITER GAUGE SCALE
613	P1026613	SET SCREW 10-24 X 5/8
614	P1026614	ROLL PIN 1.5 X 13
615	P1026615	MITER GAUGE HINGE PIN



Labels & Cosmetics

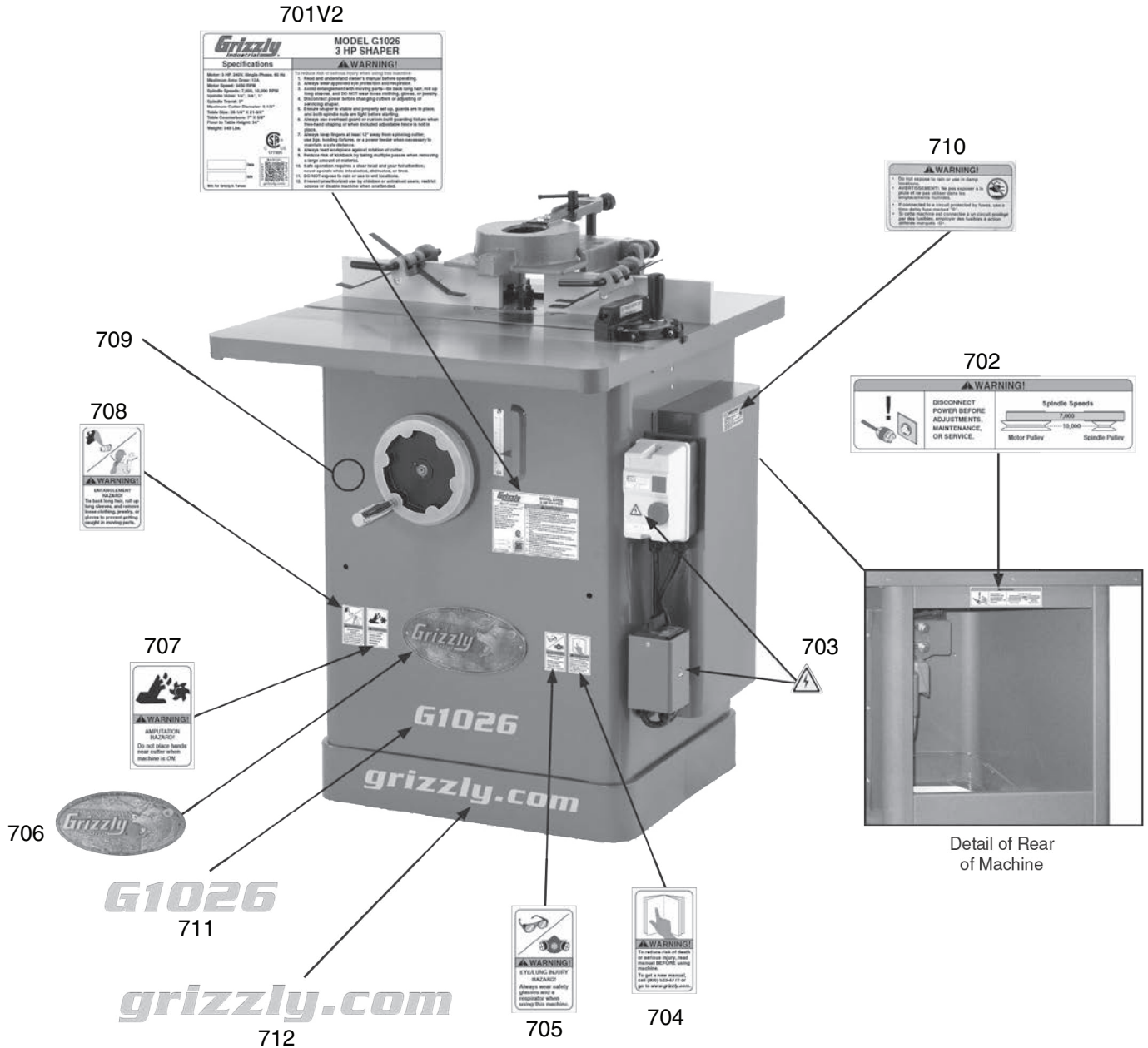

REF	PART #	DESCRIPTION
701V2	P1026701V2	MACHINE ID LABEL CSA + QR V2.10.13
702	P1026702	BELT POSITION LABEL
703	P1026703	ELECTRICITY LABEL
704	P1026704	READ MANUAL LABEL
705	P1026705	FACE SHIELD/RESPIRATOR LABEL
706	P1026706	GRIZZLY NAMEPLATE

REF	PART #	DESCRIPTION
707	P1026707	CUTTERHEAD WARNING LABEL
708	P1026708	ENTANGLEMENT HAZARD LABEL
709	P1026709	TOUCH-UP PAINT, GRIZZLY GREEN
710	P1026710	DAMPNESS WARNING LABEL
711	P1026711	MODEL NUMBER LABEL
712	P1026712	GRIZZLY.COM LABEL

⚠ WARNING

Safety labels help reduce the risk of serious injury caused by machine hazards. If any label comes off or becomes unreadable, the owner of this machine **MUST** replace it in the original location before resuming operations. For replacements, contact (800) 523-4777 or www.grizzly.com.



WARRANTY & RETURNS

Grizzly Industrial, Inc. warrants every product it sells for a period of **1 year** to the original purchaser from the date of purchase. This warranty does not apply to defects due directly or indirectly to misuse, abuse, negligence, accidents, repairs or alterations or lack of maintenance. This is Grizzly's sole written warranty and any and all warranties that may be implied by law, including any merchantability or fitness, for any particular purpose, are hereby limited to the duration of this written warranty. We do not warrant or represent that the merchandise complies with the provisions of any law or acts unless the manufacturer so warrants. In no event shall Grizzly's liability under this warranty exceed the purchase price paid for the product and any legal actions brought against Grizzly shall be tried in the State of Washington, County of Whatcom.

We shall in no event be liable for death, injuries to persons or property or for incidental, contingent, special, or consequential damages arising from the use of our products.

The manufacturers reserve the right to change specifications at any time because they constantly strive to achieve better quality equipment. We make every effort to ensure that our products meet high quality and durability standards and we hope you never need to use this warranty.

In the event you need to use this warranty, contact us by mail or phone and give us all the details. We will then issue you a "Return Number," which must be clearly posted on the outside as well as the inside of the carton. We will not accept any item back without this number. Proof of purchase must accompany the merchandise.

Please feel free to write or call us if you have any questions about the machine or the manual.

Thank you again for your business and continued support. We hope to serve you again soon.

To take advantage of this warranty, you must register it at <https://www.grizzly.com/forms/warranty>, or you can scan the QR code below to be automatically directed to our warranty registration page. Enter all applicable information for the product.



grizzly.com[®]

TOOL WEBSITE

Buy Direct and Save with Grizzly[®] – Trusted, Proven and a Great Value!
~Since 1983~

*Visit Our Website Today For
Current Specials!*

**ORDER
24 HOURS A DAY!
1-800-523-4777**

