

Grizzly **Industrial, Inc.**®

MODEL G1014Z/G1014ZX **6" X 48" BELT/9" DISC** **COMBO SANDER** **OWNER'S MANUAL**

(For models manufactured since 08/22)

G1014Z



G1014ZX



COPYRIGHT © MARCH, 2009 BY GRIZZLY INDUSTRIAL, INC., REVISED AUGUST, 2022 (CS)
**WARNING: NO PORTION OF THIS MANUAL MAY BE REPRODUCED IN ANY SHAPE
OR FORM WITHOUT THE WRITTEN APPROVAL OF GRIZZLY INDUSTRIAL, INC.**
#BL11448 PRINTED IN TAIWAN

V3.08.22

 **WARNING!**

This manual provides critical safety instructions on the proper setup, operation, maintenance, and service of this machine/tool. Save this document, refer to it often, and use it to instruct other operators.

Failure to read, understand and follow the instructions in this manual may result in fire or serious personal injury—including amputation, electrocution, or death.

The owner of this machine/tool is solely responsible for its safe use. This responsibility includes but is not limited to proper installation in a safe environment, personnel training and usage authorization, proper inspection and maintenance, manual availability and comprehension, application of safety devices, cutting/sanding/grinding tool integrity, and the usage of personal protective equipment.

The manufacturer will not be held liable for injury or property damage from negligence, improper training, machine modifications or misuse.

 **WARNING!**

Some dust created by power sanding, sawing, grinding, drilling, and other construction activities contains chemicals known to the State of California to cause cancer, birth defects or other reproductive harm. Some examples of these chemicals are:

- **Lead from lead-based paints.**
- **Crystalline silica from bricks, cement and other masonry products.**
- **Arsenic and chromium from chemically-treated lumber.**

Your risk from these exposures varies, depending on how often you do this type of work. To reduce your exposure to these chemicals: Work in a well ventilated area, and work with approved safety equipment, such as those dust masks that are specially designed to filter out microscopic particles.

Table of Contents

INTRODUCTION.....	2	SECTION 5: ACCESSORIES.....	42
Contact Info.....	2	SECTION 6: MAINTENANCE.....	43
Machine Description	2	Schedule	43
Manual Accuracy	2	Cleaning & Protecting	43
Identification.....	3	Cleaning Sanding Belt/Disc	44
Controls & Components.....	4	Lubrication	44
G1014Z Machine Data Sheet	5	SECTION 7: SERVICE	45
G1014ZX Machine Data Sheet.....	7	Troubleshooting	45
SECTION 1: SAFETY.....	9	Squaring Work Table to Sanding Belt/Disc .	47
Safety Instructions for Machinery	9	Adjusting Miter Slot-Belt/Disc Parallelism....	48
Additional Safety for Belt & Disc Sanders ...	11	Calibrating Miter Gauge.....	48
SECTION 2: POWER SUPPLY	12	V-Belt Tension & Replacement.....	49
Converting Voltage to 220V.....	14	Pulley Alignment	50
SECTION 3: SETUP	15	SECTION 8: WIRING.....	51
Needed for Setup.....	15	Wiring Safety Instructions	51
Unpacking.....	15	G1014Z Wiring Diagram	52
Hardware Recognition Chart	16	G1014ZX Wiring Diagram.....	53
G1014Z Inventory	17	SECTION 9: PARTS	54
G1014ZX Inventory.....	18	G1014Z Main	54
Cleanup.....	19	G1014Z Stand.....	56
Site Considerations.....	19	G1014Z Labels & Cosmetics	56
Anchoring to Floor	20	G1014ZX Main.....	57
Assembly	20	G1014ZX Cabinet	59
Pre-Tracking Belt.....	28	G1014ZX Labels & Cosmetics.....	60
Dust Collection.....	29	WARRANTY & RETURNS	61
Test Run	30		
SECTION 4: OPERATIONS	31		
Operation Overview	31		
Sanding Tips.....	32		
Choosing Sandpaper	32		
Workpiece Inspection.....	33		
Horizontal & Edge Sanding.....	33		
Contour Sanding.....	35		
Disc Sanding.....	35		
Vertical Sanding.....	36		
Changing Sanding Belt.....	39		
Adjusting Sanding Belt Tension.....	40		
Tracking Belt.....	41		
Changing Sanding Disc	41		

INTRODUCTION

Contact Info

We stand behind our machines! If you have questions or need help, contact us with the information below. Before contacting, make sure you get the **serial number** and **manufacture date** from the machine ID label. This will help us help you faster.

Grizzly Technical Support
1815 W. Battlefield
Springfield, MO 65807
Phone: (570) 546-9663
Email: techsupport@grizzly.com

We want your feedback on this manual. What did you like about it? Where could it be improved? Please take a few minutes to give us feedback.

Grizzly Documentation Manager
P.O. Box 2069
Bellingham, WA 98227-2069
Email: manuals@grizzly.com

Machine Description

This combination sander can be used to smooth the faces, edges, or ends of workpieces using the sanding belt or the sanding disc.

The sanding belt can be used in either the horizontal position or vertical position.

The back stop supports workpieces in the horizontal position, and the work table supports workpieces on the sanding disc or the belt when it is in the vertical position.

The work table and miter gauge can be adjusted for the desired angle.

Manual Accuracy

We are proud to provide a high-quality owner's manual with your new machine!

We made every effort to be exact with the instructions, specifications, drawings, and photographs in this manual. Sometimes we make mistakes, but our policy of continuous improvement also means that **sometimes the machine you receive is slightly different than shown in the manual.**

If you find this to be the case, and the difference between the manual and machine leaves you confused or unsure about something, check our website for an updated version. We post current manuals and manual updates for free on our website at www.grizzly.com.

Alternatively, you can call our Technical Support for help. Before calling, make sure you write down the **manufacture date** and **serial number** from the machine ID label (see below). This information is required for us to provide proper tech support, and it helps us determine if updated documentation is available for your machine.

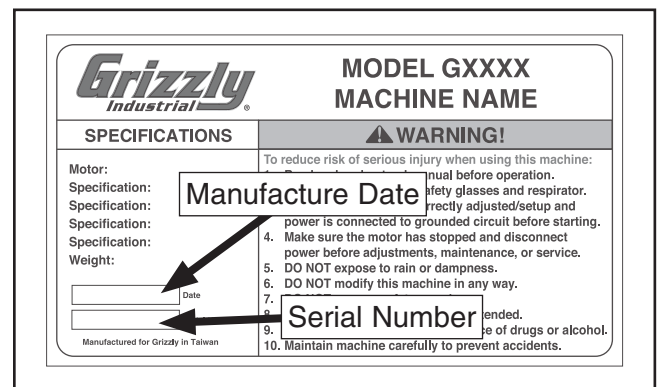

Identification

Become familiar with the names and locations of the controls and features shown below to better understand the instructions in this manual.

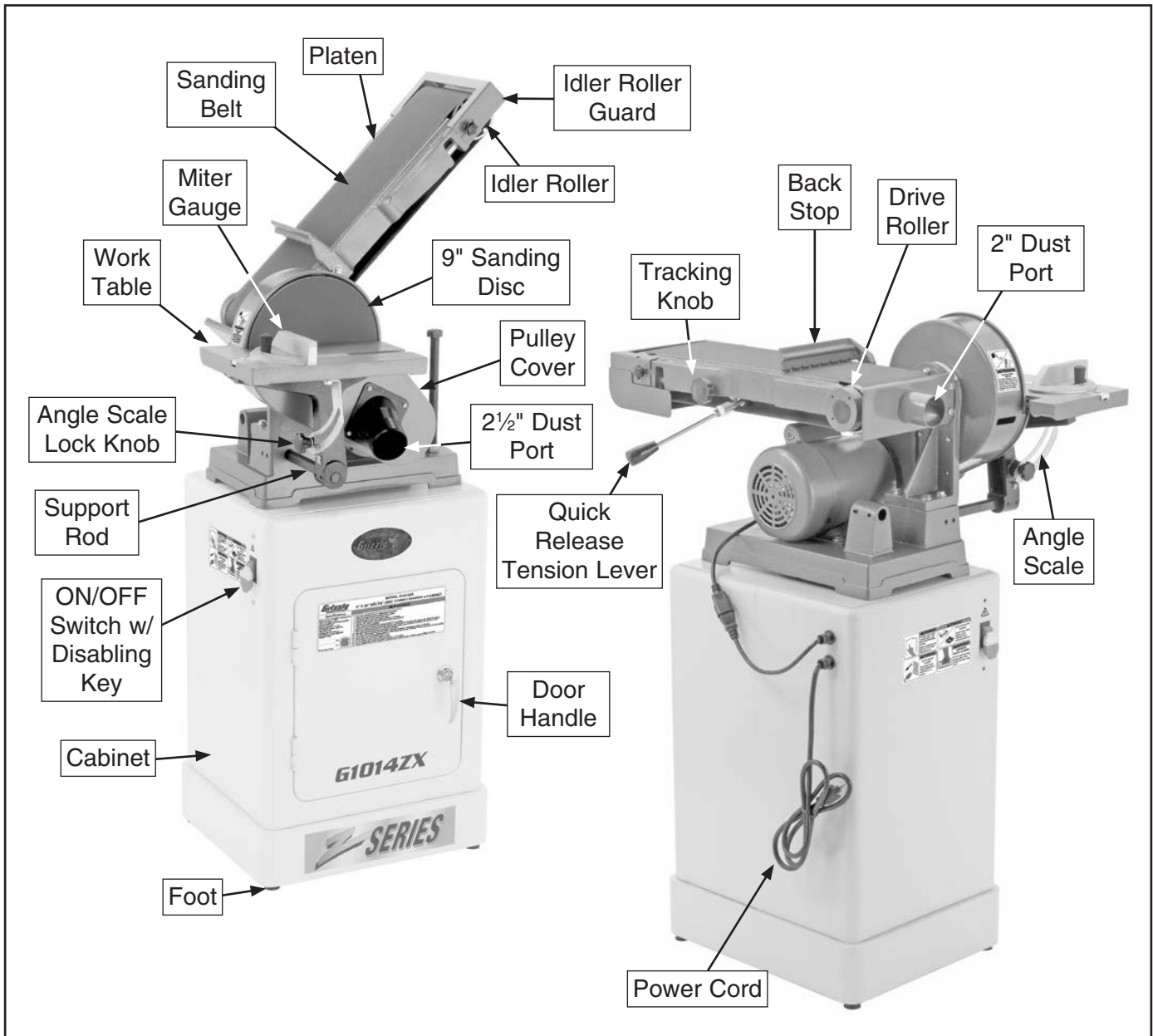

⚠️ WARNING

For Your Own Safety Read Instruction Manual Before Operating the Sander

- Wear eye and ear protection.**
- Support workpiece with miter gauge, backstop, or work table.**
- Maintain $\frac{1}{16}$ in. maximum clearance between table and sanding belt or disc.**
- Avoid kickback by sanding in accordance with directional arrows.**



Controls & Components

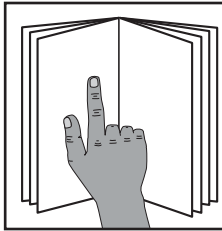

!WARNING

To reduce your risk of serious injury, read this entire manual **BEFORE** using machine.

Refer to the following figures and descriptions to become familiar with the basic controls and components of this machine. Understanding these items and how they work will help you understand the rest of the manual and minimize your risk of injury when operating this machine.

Power Controls

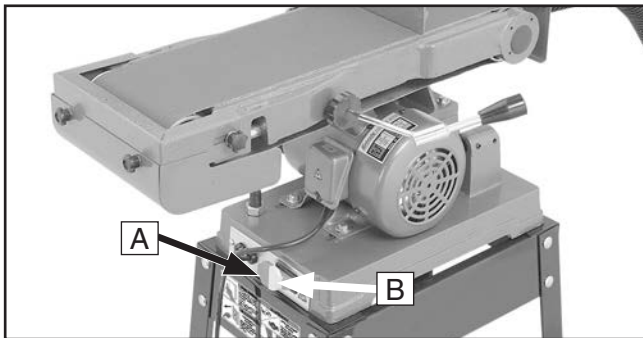

Figure 1. Paddle switch location on G1014Z.



Figure 2. Paddle switch location on G1014ZX.

- A. Paddle Switch:** Turns the motor **ON** when flipped up; turns motor **OFF** when pressed down.
- B. Switch Disabling Key:** Disables switch when the yellow key is removed.

Table Controls

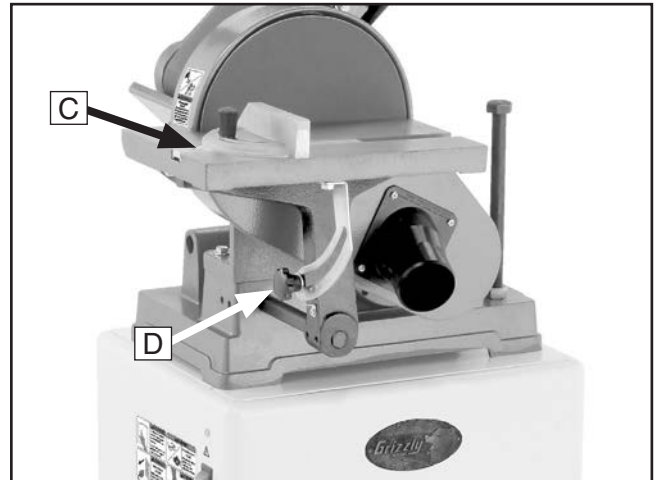

Figure 3. Table tilt controls.

- C. Miter Gauge:** Moves workpieces into the sanding disc (horizontal sanding) or belt (vertical sanding) at a specific angle. Slide miter gauge into the miter slot, loosen the lock knob, set the angle, then tighten the knob.
- D. Table Tilt Lock Knob:** Loosens to tilt the table relative to the sanding disc or the sanding belt, then tightens to secure.

Sanding Belt Controls

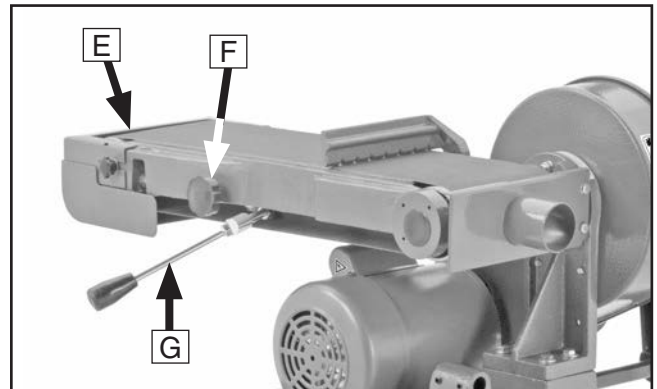

Figure 4. Sanding belt controls.

- E. Sanding Belt Frame:** Tilts between horizontal and vertical positions.
- F. Tracking Control Knob:** Adjusts belt tracking on the rollers. Loosen the lock nut on the tracking knob, turn the motor **ON**, adjust the tracking in small increments with the knob, then tighten the lock nut to secure.
- G. Quick Release Tension Lever:** Tensions the sanding belt when moved toward the motor.





MACHINE DATA SHEET

Customer Service #: (570) 546-9663 · To Order Call: (800) 523-4777 · Fax #: (800) 438-5901

MODEL G1014Z 6" X 48" BELT/9" DISC Z SERIES COMBO SANDER

Product Dimensions:

Weight..... 117 lbs.
Width (side-to-side) x Depth (front-to-back) x Height..... 30 x 24 x 56 in.
Footprint (Length x Width)..... 23 x 19 in.

Shipping Dimensions:

Type..... Cardboard Box
Content..... Machine
Weight..... 122 lbs.
Length x Width x Height..... 19 x 29 x 15 in.
Must Ship Upright..... No

Electrical:

Power Requirement..... 110V or 220V, Single-Phase, 60 Hz
Prewired Voltage..... 110V
Full-Load Current Rating..... 12A at 110V, 6A at 220V
Minimum Circuit Size..... 15A at 110V, 15A at 220V
Connection Type..... Cord & Plug
Power Cord Included..... Yes
Power Cord Length..... 6 ft.
Power Cord Gauge..... 16 AWG
Plug Included..... Yes
Included Plug Type..... 5-15 for 110V
Recommended Plug Type..... 6-15 for 220V
Switch Type..... Paddle Safety Switch w/Removable Key

Motors:

Main

Horsepower..... 3/4 HP
Phase..... Single-Phase
Amps..... 12A/6A
Speed..... 3450 RPM
Type..... TEFC Capacitor-Start Induction
Power Transfer Belt
Bearings..... Sealed & Permanently Lubricated
Centrifugal Switch/Contacts Type..... External

Main Specifications:

Belt Sander Info

Sanding Belt Width..... 6 in.
Sanding Belt Length..... 48 in.
Sanding Belt Speed..... 1900 FPM
Sanding Belt Tilt..... 90 deg.
Max Height of Belt in Vertical Position..... 56 in.
Belt Tension Release Type..... Quick Release
Platen Type..... Graphite Coated
Platen Length..... 17 in.
Platen Width..... 6-1/4 in.



Disc Sander Info

Disc Diameter..... 9 in.
Disc Speed..... 2420 RPM
Disc Sandpaper Backing Type..... PSA
Table Length..... 12-1/4 in.
Table Width..... 6 in.
Table Thickness..... 1 in.
Table Tilt..... Left 0, Right 45 deg.
Table-to-Floor Height..... 35 in.

Construction Materials

Base..... Cast Iron
Stand..... Preformed Steel
Table..... Cast Iron
Frame..... Cast Iron
Disc..... Cast Iron
Miter Gauge..... Die Cast Aluminum/Aluminum Bar
Paint Type/Finish..... Epoxy

Other Related Info

Miter Gauge Slot Width..... 3/4 in.
Miter Gauge Slot Height..... 13/32 in.
Number of Dust Ports..... 2
Dust Port Size..... 2, 2-1/2 in.
Compatible Mobile Base..... D2057A

Other Specifications:

Country of Origin Taiwan
Warranty 1 Year
Approximate Assembly & Setup Time 1-1/2 Hours
Serial Number Location ID Label
ISO 9001 Factory Yes

Features:

- 2" Dust Port for Belt and 2-1/2" Dust Port for Disc
- Quick Belt Release
- Work Table Mounts for Use on Disc or Belt
- Single Knob Tracking
- Cast-Iron Table
- Graphite Coated Platen
- Sturdy Steel Stand





MACHINE DATA SHEET

Customer Service #: (570) 546-9663 · To Order Call: (800) 523-4777 · Fax #: (800) 438-5901

MODEL G1014ZX 6" X 48" BELT/9" DISC COMBO SANDER WITH CABINET STAND

Product Dimensions:

Weight..... 148 lbs.
 Width (side-to-side) x Depth (front-to-back) x Height..... 30 x 24 x 56 in.
 Footprint (Length x Width)..... 15 x 16-1/2 in.

Shipping Dimensions:

Carton #1

Type..... Cardboard Box
 Content..... Machine
 Weight..... 106 lbs.
 Length x Width x Height..... 29 x 19 x 15 in.
 Must Ship Upright..... No

Carton #2

Type..... Cardboard Box
 Content..... Stand
 Weight..... 52 lbs.
 Length x Width x Height..... 17 x 20 x 28 in.
 Must Ship Upright..... No

Electrical:

Power Requirement..... 110V or 220V, Single-Phase, 60 Hz
 Prewired Voltage..... 110V
 Full-Load Current Rating..... 12A at 110V, 6A at 220V
 Minimum Circuit Size..... 15A at 110V, 15A at 220V
 Connection Type..... Cord & Plug
 Power Cord Included..... Yes
 Power Cord Length..... 8-1/2 ft.
 Power Cord Gauge..... 16 AWG
 Plug Included..... Yes
 Included Plug Type..... 5-15 for 110V
 Recommended Plug Type..... 6-15 for 220V
 Switch Type..... Paddle Safety Switch w/Removable Key

Motors:

Main

Horsepower..... 3/4 HP
 Phase..... Single-Phase
 Amps..... 12A/6A
 Speed..... 3450 RPM
 Type..... TEFC Capacitor-Start Induction
 Power Transfer..... Belt
 Bearings..... Sealed & Permanently Lubricated
 Centrifugal Switch/Contacts Type..... External



Main Specifications:

Belt Sander Info

Sanding Belt Width.....	6 in.
Sanding Belt Length.....	48 in.
Sanding Belt Speed.....	1900 FPM
Sanding Belt Tilt.....	90 deg.
Max Height of Belt in Vertical Position.....	58 in.
Belt Tension Release Type.....	Quick Release
Platen Type.....	Graphite Coated
Platen Length.....	17 in.
Platen Width.....	6-1/4 in.

Disc Sander Info

Disc Diameter.....	9 in.
Disc Speed.....	2420 RPM
Disc Sandpaper Backing Type.....	PSA
Table Length.....	12-1/4 in.
Table Width.....	6 in.
Table Thickness.....	1 in.
Table Tilt.....	Left 0, Right 45 deg.
Table-to-Floor Height.....	37-1/2 in.

Construction Materials

Base.....	Cast Iron
Stand.....	Sheet Metal
Table.....	Cast Iron
Frame.....	Cast Iron
Disc.....	Cast Iron
Miter Gauge.....	Die Cast Aluminum/Aluminum Bar
Paint Type/Finish.....	Powder Coated

Other Related Info

Miter Gauge Slot Width.....	3/4 in.
Miter Gauge Slot Height.....	13/32 in.
Number of Dust Ports.....	2
Dust Port Size.....	2, 2-1/2 in.
Compatible Mobile Base.....	D2260A

Other Specifications:

Country of Origin	Taiwan
Warranty	1 Year
Approximate Assembly & Setup Time	30 Minutes
Serial Number Location	ID Label
ISO 9001 Factory	Yes

Features:

- Solid Cabinet Stand
- Built-in Storage Shelf
- Quick Belt Release Mechanism
- Cast-Iron Table, Disc and Body



SECTION 1: SAFETY

For Your Own Safety, Read Instruction Manual Before Operating This Machine

The purpose of safety symbols is to attract your attention to possible hazardous conditions. This manual uses a series of symbols and signal words intended to convey the level of importance of the safety messages. The progression of symbols is described below. Remember that safety messages by themselves do not eliminate danger and are not a substitute for proper accident prevention measures. Always use common sense and good judgment.

 **DANGER** Indicates an imminently hazardous situation which, if not avoided, **WILL** result in death or serious injury.

 **WARNING** Indicates a potentially hazardous situation which, if not avoided, **COULD** result in death or serious injury.

 **CAUTION** Indicates a potentially hazardous situation which, if not avoided, **MAY** result in minor or moderate injury. It may also be used to alert against unsafe practices.

NOTICE Alerts the user to useful information about proper operation of the machine to avoid machine damage.

Safety Instructions for Machinery

WARNING

OWNER'S MANUAL. Read and understand this owner's manual **BEFORE** using machine.

TRAINED OPERATORS ONLY. Untrained operators have a higher risk of being hurt or killed. Only allow trained/supervised people to use this machine. When machine is not being used, disconnect power, remove switch keys, or lock-out machine to prevent unauthorized use—especially around children. Make your workshop kid proof!

DANGEROUS ENVIRONMENTS. Do not use machinery in areas that are wet, cluttered, or have poor lighting. Operating machinery in these areas greatly increases the risk of accidents and injury.

MENTAL ALERTNESS REQUIRED. Full mental alertness is required for safe operation of machinery. Never operate under the influence of drugs or alcohol, when tired, or when distracted.

ELECTRICAL EQUIPMENT INJURY RISKS. You can be shocked, burned, or killed by touching live electrical components or improperly grounded machinery. To reduce this risk, only allow qualified service personnel to do electrical installation or repair work, and always disconnect power before accessing or exposing electrical equipment.

DISCONNECT POWER FIRST. Always disconnect machine from power supply **BEFORE** making adjustments, changing tooling, or servicing machine. This prevents an injury risk from unintended startup or contact with live electrical components.

EYE PROTECTION. Always wear ANSI-approved safety glasses or a face shield when operating or observing machinery to reduce the risk of eye injury or blindness from flying particles. Everyday eyeglasses are **NOT** approved safety glasses.



WARNING

WEARING PROPER APPAREL. Do not wear clothing, apparel or jewelry that can become entangled in moving parts. Always tie back or cover long hair. Wear non-slip footwear to reduce risk of slipping and losing control or accidentally contacting cutting tool or moving parts.

HAZARDOUS DUST. Dust created by machinery operations may cause cancer, birth defects, or long-term respiratory damage. Be aware of dust hazards associated with each workpiece material. Always wear a NIOSH-approved respirator to reduce your risk.

HEARING PROTECTION. Always wear hearing protection when operating or observing loud machinery. Extended exposure to this noise without hearing protection can cause permanent hearing loss.

REMOVE ADJUSTING TOOLS. Tools left on machinery can become dangerous projectiles upon startup. Never leave chuck keys, wrenches, or any other tools on machine. Always verify removal before starting!

USE CORRECT TOOL FOR THE JOB. Only use this tool for its intended purpose—do not force it or an attachment to do a job for which it was not designed. Never make unapproved modifications—modifying tool or using it differently than intended may result in malfunction or mechanical failure that can lead to personal injury or death!

AWKWARD POSITIONS. Keep proper footing and balance at all times when operating machine. Do not overreach! Avoid awkward hand positions that make workpiece control difficult or increase the risk of accidental injury.

CHILDREN & BYSTANDERS. Keep children and bystanders at a safe distance from the work area. Stop using machine if they become a distraction.

GUARDS & COVERS. Guards and covers reduce accidental contact with moving parts or flying debris. Make sure they are properly installed, undamaged, and working correctly **BEFORE** operating machine.

FORCING MACHINERY. Do not force machine. It will do the job safer and better at the rate for which it was designed.

NEVER STAND ON MACHINE. Serious injury may occur if machine is tipped or if the cutting tool is unintentionally contacted.

STABLE MACHINE. Unexpected movement during operation greatly increases risk of injury or loss of control. Before starting, verify machine is stable and mobile base (if used) is locked.

USE RECOMMENDED ACCESSORIES. Consult this owner's manual or the manufacturer for recommended accessories. Using improper accessories will increase the risk of serious injury.

UNATTENDED OPERATION. To reduce the risk of accidental injury, turn machine **OFF** and ensure all moving parts completely stop before walking away. Never leave machine running while unattended.

MAINTAIN WITH CARE. Follow all maintenance instructions and lubrication schedules to keep machine in good working condition. A machine that is improperly maintained could malfunction, leading to serious personal injury or death.

DAMAGED PARTS. Regularly inspect machine for damaged, loose, or mis-adjusted parts—or any condition that could affect safe operation. Immediately repair/replace **BEFORE** operating machine. For your own safety, **DO NOT** operate machine with damaged parts!

MAINTAIN POWER CORDS. When disconnecting cord-connected machines from power, grab and pull the plug—**NOT** the cord. Pulling the cord may damage the wires inside. Do not handle cord/plug with wet hands. Avoid cord damage by keeping it away from heated surfaces, high traffic areas, harsh chemicals, and wet/damp locations.

EXPERIENCING DIFFICULTIES. If at any time you experience difficulties performing the intended operation, stop using the machine! Contact our Technical Support at (570) 546-9663.



Additional Safety for Belt & Disc Sanders

WARNING

Serious injury or death can occur from fingers, clothing, jewelry, or hair getting pinched/entangled in rotating disc, belt, spindle or other moving components. Abrasion injuries can occur from touching moving sandpaper with bare skin. Workpieces thrown by sanding surface can strike operator or bystanders with moderate force, causing impact injuries. Long-term respiratory damage can occur from using sander without proper use of a respirator. To reduce the risk of these hazards, operator or bystanders **MUST** completely heed the hazards and warnings below.

SANDPAPER DIRECTION. Feeding workpiece incorrectly can cause it to be thrown from machine, striking operator or bystanders, or causing your hands to slip into the moving sandpaper. To reduce these risks, only sand against direction of sandpaper travel, ensure workpiece is properly supported, and avoid introducing sharp edges into moving sandpaper on the leading side of the workpiece.

IN-RUNNING NIP POINTS. The gap between moving sandpaper and fixed table/support creates a pinch point for fingers or workpieces; the larger this gap is, the greater the risk of fingers or workpieces getting caught in it. Minimize this risk by adjusting table/support to no more than $\frac{1}{16}$ " away from sandpaper.

HAND PLACEMENT. Rotating sandpaper can remove skin quickly. Always keep hands away from moving sandpaper during operation. Stop machine to clean table of sawdust and chips.

MINIMUM STOCK DIMENSION. Small workpieces can be aggressively pulled from your hands, causing contact with sanding surface. Always use a jig or other holding device when sanding small workpieces, and keep hands and fingers at least 2" away from sanding surface.

FEEDING WORKPIECE. Forcefully jamming workpiece into sanding surface could cause it to be grabbed aggressively, pulling hands into sanding surface. Firmly grasp workpiece in both hands and ease it into sandpaper using light pressure.

AVOIDING ENTANGLEMENT. Becoming entangled in moving parts can cause pinching and crushing injuries. To avoid these hazards, keep all guards in place and closed. **DO NOT** wear loose clothing, gloves, or jewelry, and tie back long hair.

WORKPIECE SUPPORT. Workpiece kickback can occur with violent force if workpiece is not properly supported during operation. Always sand with workpiece firmly against table or another support device.

SANDING DUST. Sanding creates large amounts of dust that can lead to eye injury or respiratory illness. Reduce your risk by always wearing approved eye and respiratory protection when using sander. Never operate without adequate dust collection system in place and running. However, dust collection is not a substitute for using a respirator.

WORKPIECE INSPECTION. Nails, staples, knots, or other imperfections in workpiece can be dislodged and thrown from sander at a high rate of speed at people, or cause damage to sandpaper or sander. Never sand stock that has embedded foreign objects or questionable imperfections.

SANDPAPER CONDITION. Worn or damaged sandpaper can fly apart and throw debris at operator, or aggressively grab workpiece, resulting in subsequent injuries from operator loss of workpiece control. Always inspect sandpaper before operation and replace if worn or damaged.

WORKPIECE INTEGRITY. Sanding fragile workpieces can result in loss of control, resulting in abrasion injuries, impact injuries, or damage to sandpaper. Only sand solid workpieces that can withstand power sanding forces. Make sure workpiece shape is properly supported; avoid sanding workpieces without flat bottom surfaces unless some type of jig is used to maintain support and control when sanding force is applied.



SECTION 2: POWER SUPPLY

Availability

Before installing the machine, consider the availability and proximity of the required power supply circuit. If an existing circuit does not meet the requirements for this machine, a new circuit must be installed. To minimize the risk of electrocution, fire, or equipment damage, installation work and electrical wiring must be done by an electrician or qualified service personnel in accordance with all applicable codes and standards.

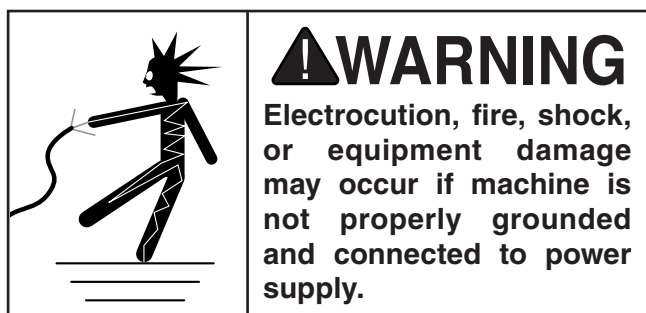

Full-Load Current Rating

The full-load current rating is the amperage a machine draws at 100% of the rated output power. On machines with multiple motors, this is the amperage drawn by the largest motor or sum of all motors and electrical devices that might operate at one time during normal operations.

Full-Load Current Rating at 110V..... 12 Amps

Full-Load Current Rating at 220V 6 Amps

The full-load current is not the maximum amount of amps that the machine will draw. If the machine is overloaded, it will draw additional amps beyond the full-load rating.

If the machine is overloaded for a sufficient length of time, damage, overheating, or fire may result—especially if connected to an undersized circuit. To reduce the risk of these hazards, avoid overloading the machine during operation and make sure it is connected to a power supply circuit that meets the specified circuit requirements.

Circuit Information

A power supply circuit includes all electrical equipment between the breaker box or fuse panel in the building and the machine. The power supply circuit used for this machine must be sized to safely handle the full-load current drawn from the machine for an extended period of time. (If this machine is connected to a circuit protected by fuses, use a time delay fuse marked D.)



Note: *Circuit requirements in this manual apply to a dedicated circuit—where only one machine will be running on the circuit at a time. If machine will be connected to a shared circuit where multiple machines may be running at the same time, consult an electrician or qualified service personnel to ensure circuit is properly sized for safe operation.*

Circuit Requirements for 110V

This machine is prewired to operate on a power supply circuit that has a verified ground and meets the following requirements:

Nominal Voltage 110V, 115V, 120V
Cycle 60 Hz
Phase Single-Phase
Circuit Rating 15 Amps
Plug/Receptacle NEMA 5-15

Circuit Requirements for 220V

This machine can be converted to operate on a power supply circuit that has a verified ground and meets the requirements listed below. (Refer to **Voltage Conversion** instructions for details.)

Nominal Voltage 208V, 220V, 230V, 240V
Cycle 60 Hz
Phase Single-Phase
Circuit Rating 15 Amps
Plug/Receptacle NEMA 6-15



Grounding Requirements

This machine **MUST** be grounded. In the event of certain malfunctions or breakdowns, grounding reduces the risk of electric shock by providing a path of least resistance for electric current.

For 110V operation: This machine is equipped with a power cord that has an equipment-grounding wire and a grounding plug (see following figure). The plug must only be inserted into a matching receptacle (outlet) that is properly installed and grounded in accordance with all local codes and ordinances.

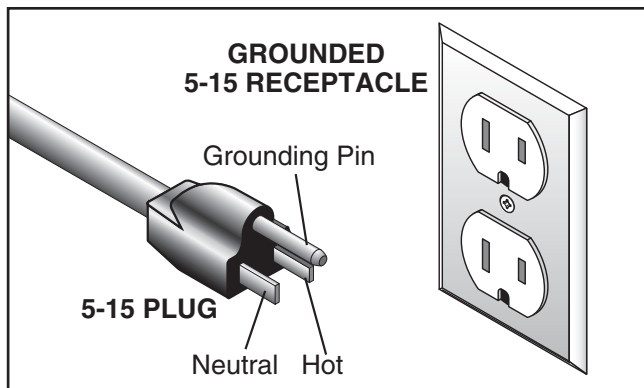

Figure 5. Typical 5-15 plug and receptacle.

⚠ CAUTION

SHOCK HAZARD!

Two-prong outlets do not meet the grounding requirements for this machine. Do not modify or use an adapter on the plug provided—if it will not fit the outlet, have a qualified electrician install the proper outlet with a verified ground.

For 220V operation: The plug specified under “Circuit Requirements for 220V” on the previous page has a grounding prong that must be attached to the equipment-grounding wire on the included power cord. The plug must only be inserted into a matching receptacle (see following figure) that is properly installed and grounded in accordance with all local codes and ordinances.

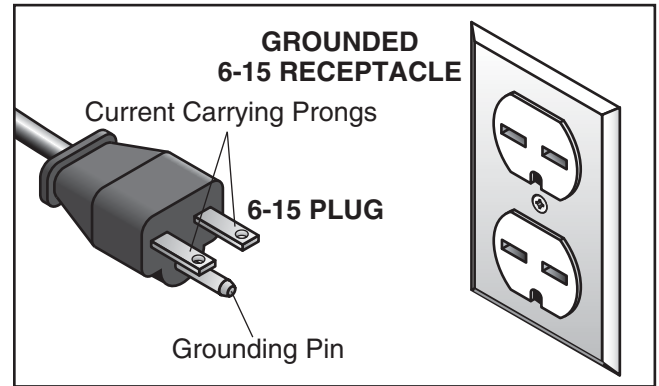

Figure 6. Typical 6-15 plug and receptacle.

Improper connection of the equipment-grounding wire can result in a risk of electric shock. The wire with green insulation (with or without yellow stripes) is the equipment-grounding wire. If repair or replacement of the power cord or plug is necessary, do not connect the equipment-grounding wire to a live (current carrying) terminal.

Check with a qualified electrician or service personnel if you do not understand these grounding requirements, or if you are in doubt about whether the tool is properly grounded. If you ever notice that a cord or plug is damaged or worn, disconnect it from power, and immediately replace it with a new one.

Extension Cords

We do not recommend using an extension cord with this machine. If you must use an extension cord, only use it if absolutely necessary and only on a temporary basis.

Extension cords cause voltage drop, which can damage electrical components and shorten motor life. Voltage drop increases as the extension cord size gets longer and the gauge size gets smaller (higher gauge numbers indicate smaller sizes).

Any extension cord used with this machine must be in good condition and contain a ground wire and matching plug/receptacle. Additionally, it must meet the following size requirements:

Minimum Gauge Size14 AWG
Maximum Length (Shorter is Better).....50 ft.



Converting Voltage to 220V

The voltage conversion **MUST** be performed by an electrician or qualified service personnel.

The voltage conversion procedure consists of rewiring the motor and installing the correct plug. A wiring diagram for each machine is provided for your reference in the back of this manual, beginning on **Page 52**.

Items Needed

Qty

- Phillips Head Screwdriver #2 1
- Electrical Tape As Needed
- Wire Cutters/Stripper 1
- NEMA 6-15 Plug 1

To convert the machine to 220V operation:

1. DISCONNECT MACHINE FROM POWER!
2. Cut off the existing 5-15 plug.
3. Open the motor junction box, then loosen two wire nuts indicated in **Figure 7**.

4. Use wire nuts to connect wires as indicated in **Figure 8**. Twist wire nuts onto their respective wires and wrap them with electrical tape so they will not come loose during operation.

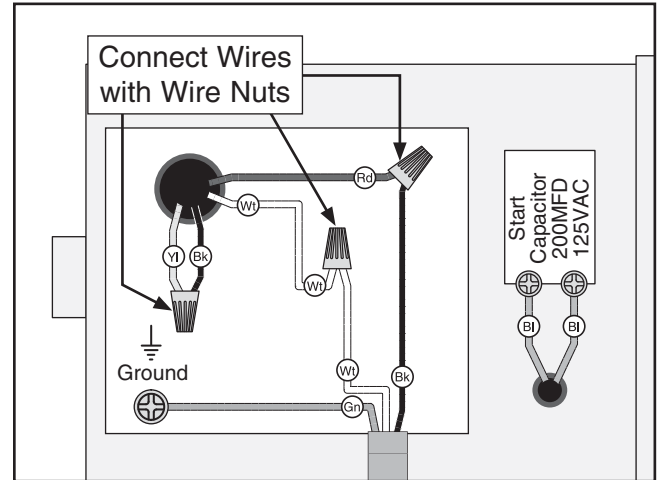

Figure 8. Motor rewired for 220V.

5. Close and secure motor junction box.
6. Install 6-15 plug on power cord, according to plug manufacturer's instructions.
 - If plug manufacturer's instructions are not available, NEMA standard 6-15 plug wiring is provided beginning on **Page 52**.

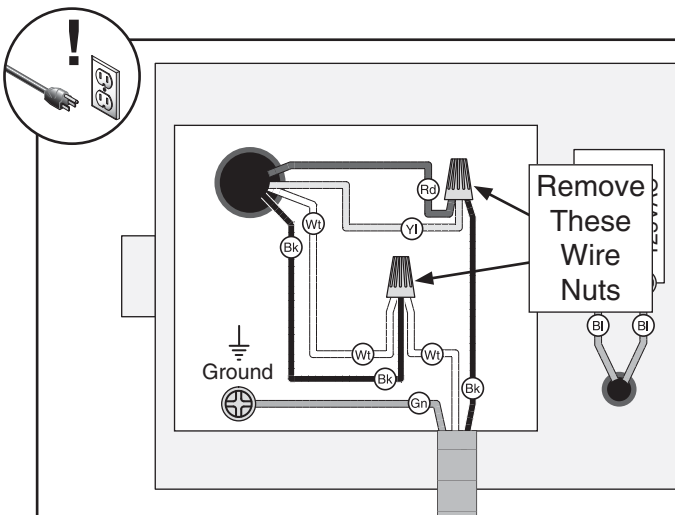
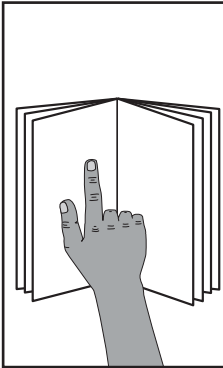

Figure 7. Motor prewired for 110V.



SECTION 3: SETUP



!WARNING

This machine presents serious injury hazards to untrained users. Read through this entire manual to become familiar with the controls and operations before starting the machine!

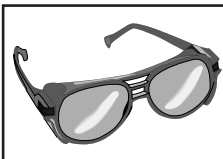

!WARNING

Wear safety glasses during the entire setup process!

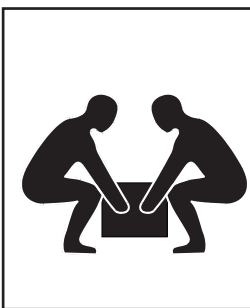

!WARNING

This machine and its components are very heavy. Get lifting help or use power lifting equipment such as a forklift to move heavy items.

!WARNING

Like all machinery there is potential danger when operating this machine. Accidents are frequently caused by lack of familiarity or failure to pay attention. Use this machine with respect and caution to decrease the risk of operator injury. If normal safety precautions are overlooked or ignored, serious personal injury may occur.

!CAUTION

No list of safety guidelines can be complete. Every shop environment is different. Always consider safety first, as it applies to your individual working conditions. Use this and other machinery with caution and respect. Failure to do so could result in serious personal injury, damage to equipment, or poor work results.

Needed for Setup

The following items are needed, but not included, for the setup/assembly of this machine.

Description	Qty
• Safety Glasses	1
• Cleaner/Degreaser	As Needed
• Disposable Shop Rags.....	As Needed
• Disposable Gloves	As Needed
• Additional People	1
• Open-End Wrench 1/2", 9/16"	1 Ea.
• Level	1
• Shims	As Needed
• Phillips Head Screwdriver #2	1
• Ruler	1
• Machinist's Square	1
• Wrench or Socket 3/8", 7/16"	1 Ea.
• Dust Hose 2"	1
• Hose Clamps 2"	2
• Dust Hose 2 1/2"	1
• Hose Clamps 2 1/2"	2
• Hose Adapters 4" x 2", 4" x 2 1/2"	1 Ea.
• Dust Hoses 4"	3
• Hose Clamps 4"	5
• Hose Y-Fitting 4" x 4" x 4"	1
• Dust Collector.....	1

Unpacking

This machine was carefully packaged for safe transport. When unpacking, separate all enclosed items from packaging materials and inspect them for shipping damage. ***If items are damaged, please call us immediately at (570) 546-9663.***







IMPORTANT: Save all packaging materials until you are completely satisfied with the machine and have resolved any issues between Grizzly or the shipping agent. ***You MUST have the original packaging to file a freight claim. It is also extremely helpful if you need to return your machine later.***









Hardware Recognition Chart

USE THIS CHART TO MATCH UP HARDWARE DURING THE ASSEMBLY PROCESS.

MEASURE BOLT DIAMETER BY PLACING INSIDE CIRCLE

-  #10
-  1/4"
-  5/16"
-  3/8"
-  7/16"
-  1/2"

-  4mm
-  5mm
-  6mm
-  8mm
-  10mm
-  12mm
-  16mm

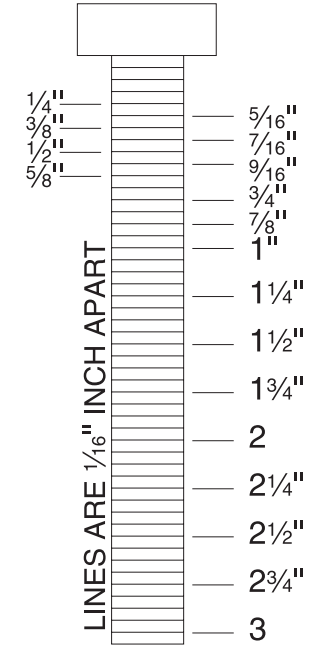
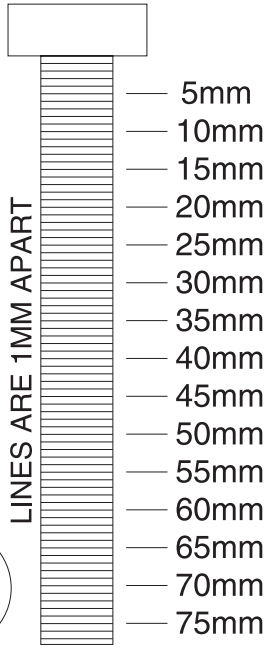
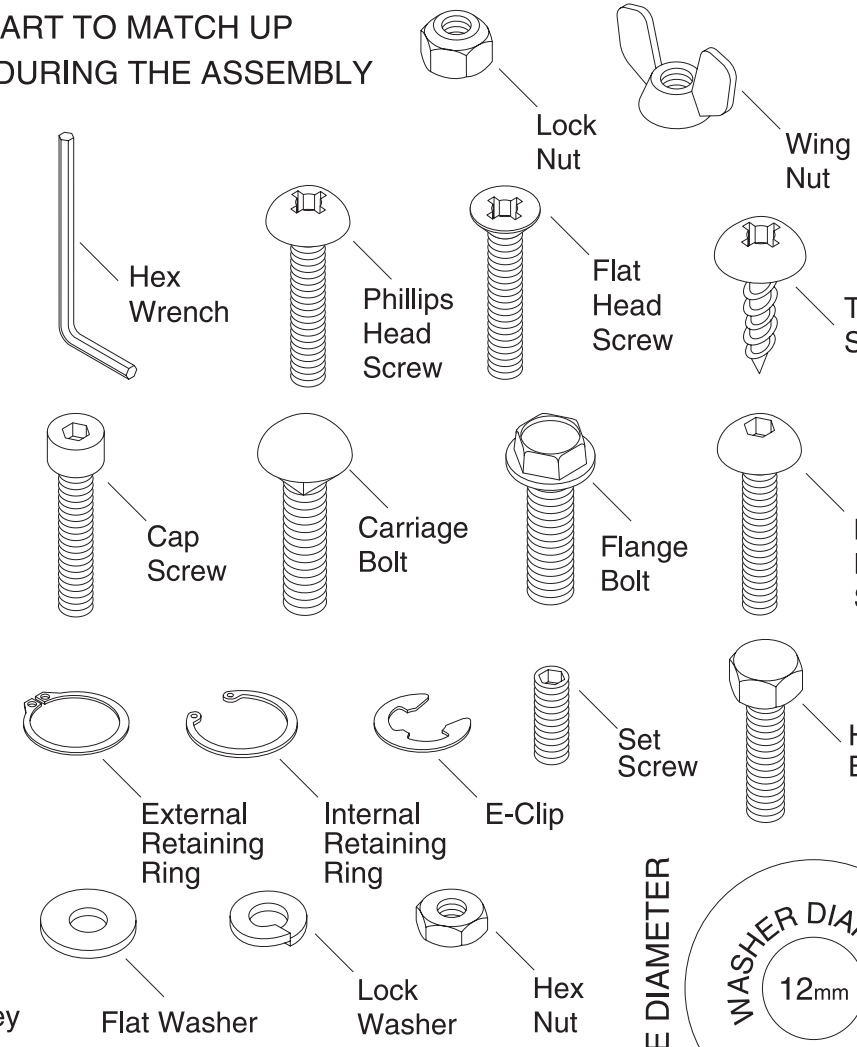

WASHERS ARE MEASURED BY THE INSIDE DIAMETER

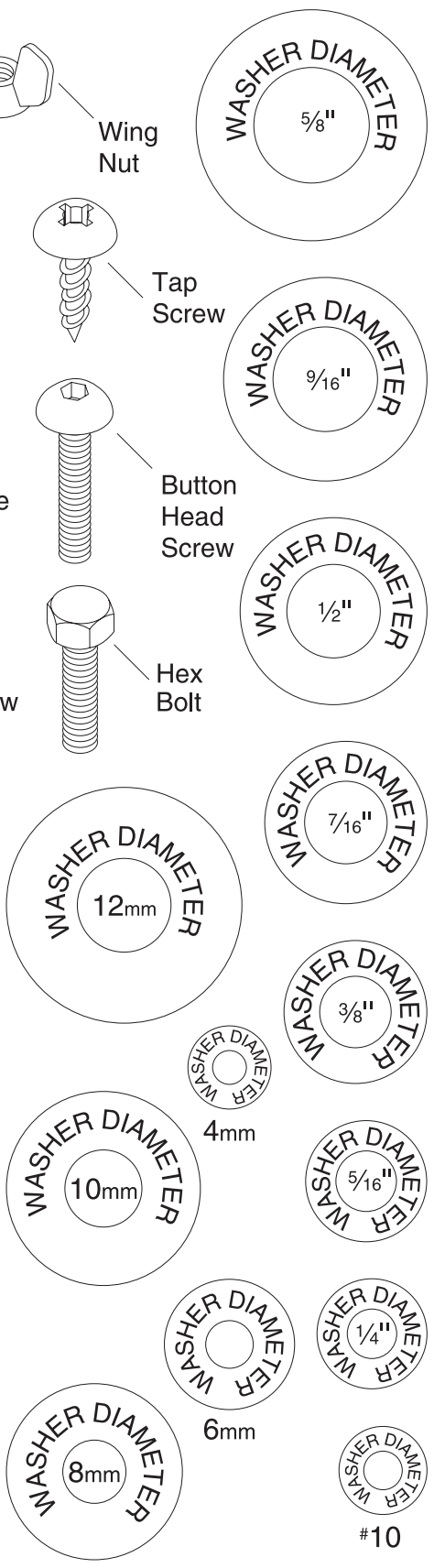

G1014Z Inventory

The following is a list of items shipped with your machine. Before beginning setup, lay these items out and inventory them.

If any non-proprietary parts are missing (e.g. a nut or a washer), we will gladly replace them; or for the sake of expediency, replacements can be obtained at your local hardware store.

Box 1 (Figures 9–11)	Qty
A. Sander Unit	1
B. Stand Legs	4
C. Long Lower Braces	2
D. Long Upper Braces	2
E. Short Lower Braces.....	2
F. Short Upper Braces.....	2
G. Sanding Belt 6" x 48"	1
H. Dust Port 2½" (Black).....	1
I. Work Table	1
J. Miter Gauge.....	1
K. Back Stop.....	1
L. Rubber Feet	4
M. Table Support Rod	1
N. Quick Release Lever Stud 6"	1
O. Short Lever Arm	1
P. Quick Release Lever Handle	1
Q. Idler Roller	1
R. Idler Roller Guard.....	1
S. Dust Port 2" (Green).....	1
T. Cast Iron Plate.....	1
U. Sanding Disc 9".....	1

Hardware & Tools (not shown)	Qty
• Hex Wrench 4mm.....	1
• Hex Bolts 5/16"-18 x 1" (Feet)	4
• Hex Nuts 5/16"-18 (Feet, Stand)	36
• Flat Washers 5/16" (Feet, Stand).....	40
• Hex Bolts 5/16"-18 x 1/2" (Stand & Sander)	4
• Carriage Bolts 5/16"-18 x 1/2" (Stand).....	32
• Phillip Head Screws 10-24 x 3/8" (2½" Dust Port).....	4
• Hex Nuts 10-24 (2½" Dust Port).....	4
• Flat Washers #10 (2½" Dust Port).....	4
• Hex Nuts 3/8"-16 (Quick Release Lever)	2
• Thumb Knobs 1/4"-20 x 1/2" (Sander Unit).....	2
• Flat Washers 1/4" (Sander Unit).....	2
• Thumb Knobs M5-8 x 10 (Roller Guard)	2
• Flat Washers #10 (Roller Guard).....	2
• Lock Washers #10 (Roller Guard)	2

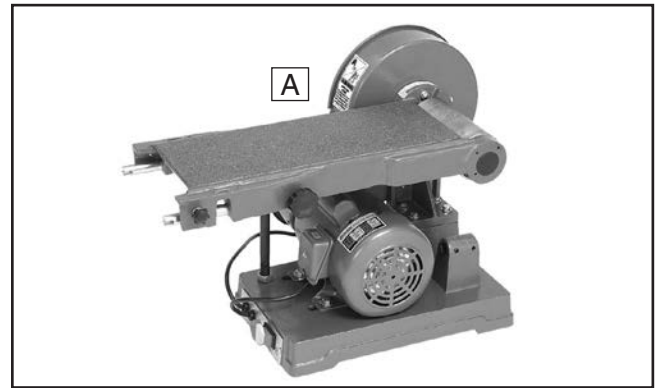

Figure 9. G1014Z sander unit.

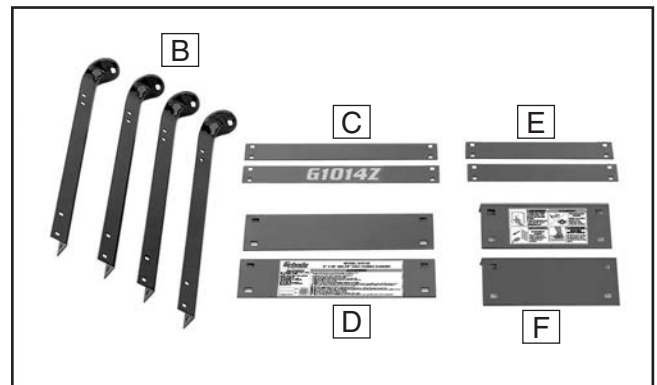

Figure 10. G1014Z stand components.

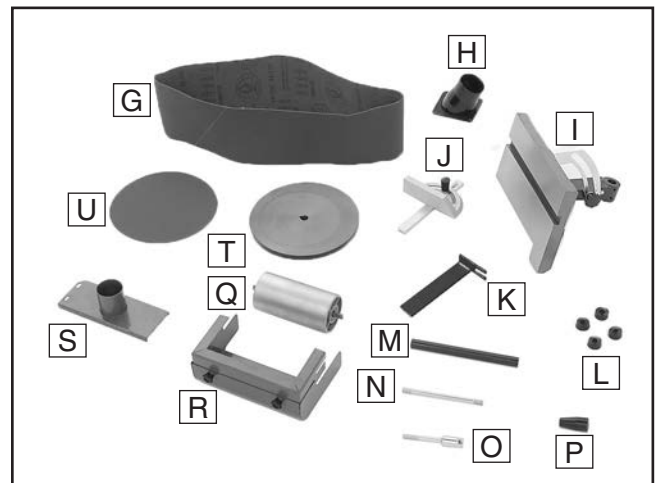

Figure 11. Loose inventory items.

NOTICE

If you cannot find an item on this list, carefully check around/inside the machine and packaging materials. Often, these items get lost in packaging materials while unpacking or they are pre-installed at the factory.



G1014ZX Inventory

The following is a list of items shipped with your machine. Before beginning setup, lay these items out and inventory them.

If any non-proprietary parts are missing (e.g. a nut or a washer), we will gladly replace them; or for the sake of expediency, replacements can be obtained at your local hardware store.

Box 1 (Figures 12–13)	Qty
A. Sander Unit	1
B. Sanding Belt 6" x 48"	1
C. Dust Port 2½" (Black).....	1
D. Work Table	1
E. Miter Gauge.....	1
F. Back Stop.....	1
G. Rubber Feet (Cabinet).....	4
H. Quick Release Lever Handle	1
I. Table Support Rod	1
J. Quick Release Lever Stud 6"	1
K. Short Lever Arm	1
L. Idler Roller Guard.....	1
M. Idler Roller	1
N. Cast Iron Plate.....	1
O. Sanding Disc 9".....	1
P. Dust Port 2" (Green).....	1

Hardware & Tools (not shown)	Qty
• Hex Wrench 4mm.....	1
• Hex Bolts 5/16"-18 x 1½" (Sander & Cabinet) .	4
• Flat Washers 5/16" (Sander & Cabinet).....	4
• Phillip Head Screws 10-24 x 3/8" (2½" Dust Port).....	4
• Hex Nuts 10-24 (2½" Dust Port).....	4
• Flat Washers #10 (2½" Dust Port).....	4
• Hex Nuts 3/8"-16 (Quick Release Lever)	2

Box 2 (Figure 14)	Qty
Q. Cabinet	1
R. Shelf	1

Hardware (not shown)	Qty
• Hex Nuts 5/16"-18 (Cabinet)	4
• Hex Bolts 5/16"-18 x 1" (Cabinet).....	4
• Flat Washers 5/16" (Cabinet)	4
• Thumb Knobs ¼"-20 x ½" (Sander Unit).....	2
• Flat Washers ¼" (Sander Unit).....	2
• Thumb Knobs M5-.8 x 10 (Roller Guard)....	2
• Flat Washers #10 (Roller Guard).....	2
• Lock Washers #10 (Roller Guard)	2

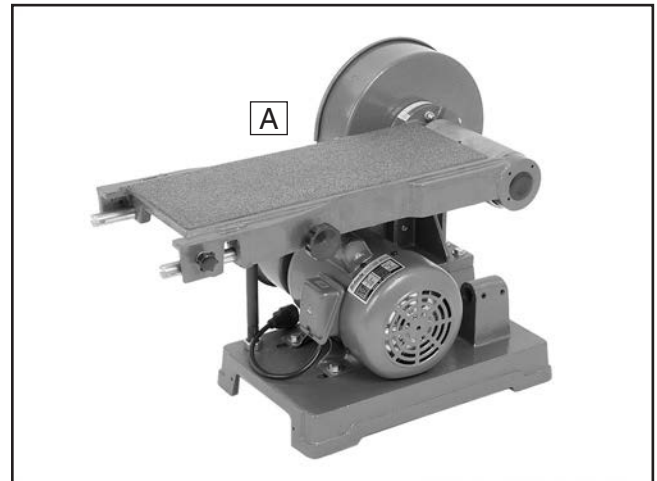

Figure 12. G1014ZX sander unit.

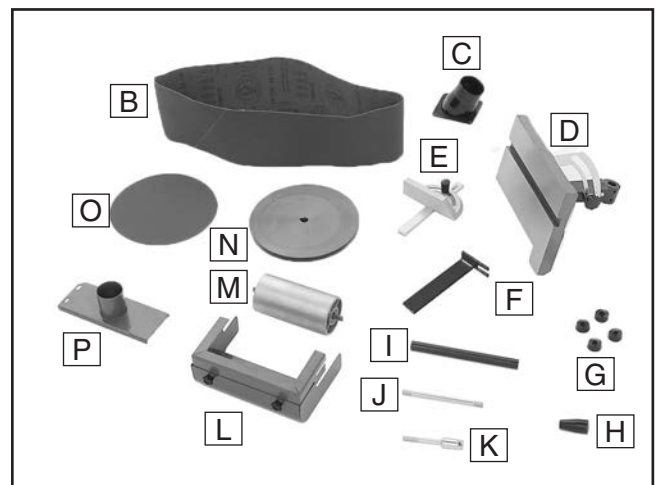

Figure 13. G1014ZX loose inventory items.

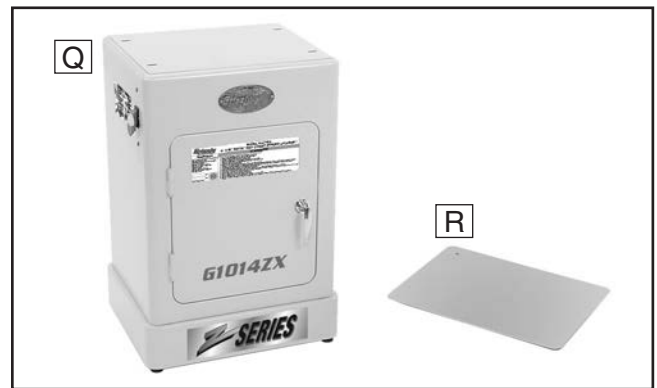

Figure 14. Cabinet inventory.

NOTICE

If you cannot find an item on this list, carefully check around/inside the machine and packaging materials. Often, these items get lost in packaging materials while unpacking or they are pre-installed at the factory.



Cleanup

The unpainted surfaces of your machine are coated with a heavy-duty rust preventative that prevents corrosion during shipment and storage. This rust preventative works extremely well, but it will take a little time to clean.

Be patient and do a thorough job cleaning your machine. The time you spend doing this now will give you a better appreciation for the proper care of your machine's unpainted surfaces.

There are many ways to remove this rust preventative, but the following steps work well in a wide variety of situations. Always follow the manufacturer's instructions with any cleaning product you use and make sure you work in a well-ventilated area to minimize exposure to toxic fumes.

Before cleaning, gather the following:

- Disposable rags
- Cleaner/degreaser (WD-40 works well)
- Safety glasses & disposable gloves
- Plastic paint scraper (optional)

Basic steps for removing rust preventative:

1. Put on safety glasses.
2. Coat the rust preventative with a liberal amount of cleaner/degreaser, then let it soak for 5–10 minutes.
3. Wipe off the surfaces. If your cleaner/degreaser is effective, the rust preventative will wipe off easily. If you have a plastic paint scraper, scrape off as much as you can first, then wipe off the rest with the rag.
4. Repeat **Steps 2–3** as necessary until clean, then coat all unpainted surfaces with a quality metal protectant to prevent rust.

NOTICE

Avoid harsh solvents like acetone or brake parts cleaner that may damage painted surfaces. Always test on a small, inconspicuous location first.

Site Considerations

Floor Load

Refer to the **Machine Data Sheet** for the weight and footprint specifications of your machine. Some residential floors or workbenches may require additional reinforcement to support the machine and operator or machine and workpiece.

Placement Location

Consider existing and anticipated needs, size of material to be processed through each machine, and space for auxiliary stands, work tables or other machinery when establishing a location for your new machine. See **Figure 15** for the minimum working clearances.

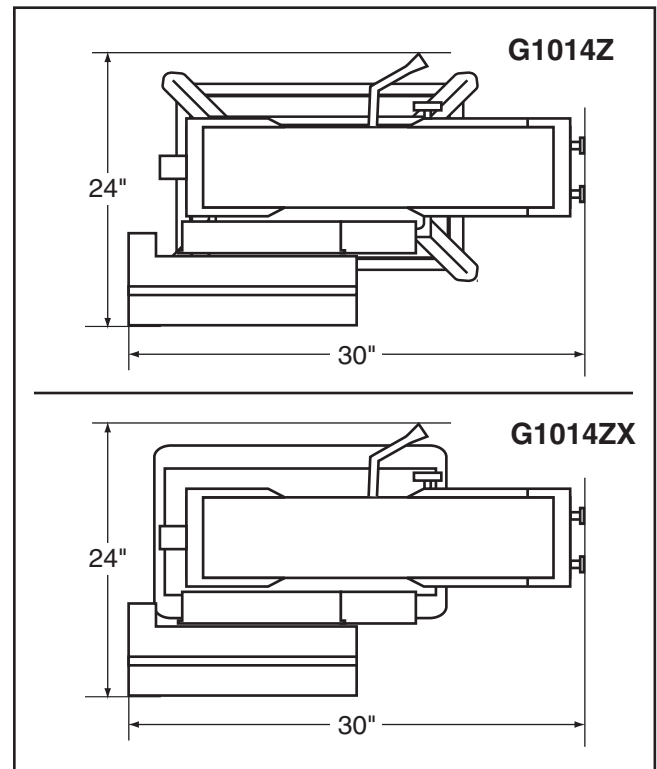

Figure 15. Minimum working clearances.



Anchoring to Floor

Number of Mounting Holes 4
Diameter of Mounting Hardware..... $\frac{5}{16}$ "

We recommend mounting the Model G1014Z to the floor. Use machine mounts on the Model G1014ZX because the mounting holes cannot be accessed through the cabinet.

Anchoring machinery to the floor prevents tipping or shifting and reduces vibration that may occur during operation, resulting in a machine that runs slightly quieter and feels more solid.

If the machine will be installed in a commercial or workplace setting, or if it is permanently connected (hardwired) to the power supply, local codes may require that it be anchored to the floor.

If not required by any local codes, fastening the machine to the floor is an optional step. If you choose not to do this with your machine, we recommend placing it on machine mounts, as these provide an easy method for leveling and they have vibration-absorbing pads.

Anchoring to Concrete Floors

Lag shield anchors with lag screws (see below) are a popular way to anchor machinery to a concrete floor, because the anchors sit flush with the floor surface, making it easy to unbolt and move the machine later, if needed. However, anytime local codes apply, you **MUST** follow the anchoring methodology specified by the code.

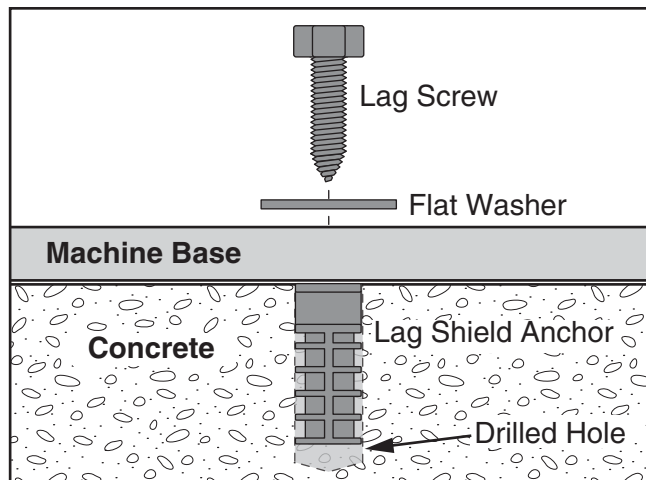

Figure 16. Popular method for anchoring machinery to a concrete floor.

Assembly

The machine must be fully assembled before it can be operated. Before beginning the assembly process, refer to **Needed for Setup** and gather all listed items. To ensure the assembly process goes smoothly, first clean any parts that are covered or coated in heavy-duty rust preventative (if applicable).

For the Model G1014Z, begin assembly with **Step 1**. For the Model G1014ZX, begin assembly with **Step 11**.

To assemble machine:

1. Insert a $\frac{5}{16}$ "-18 x 1" hex bolt through bottom of rubber foot, then insert foot into bottom of leg and fasten it finger tight with $\frac{5}{16}$ "-18 hex nut and $\frac{5}{16}$ " flat washer, as shown in **Figure 17**.

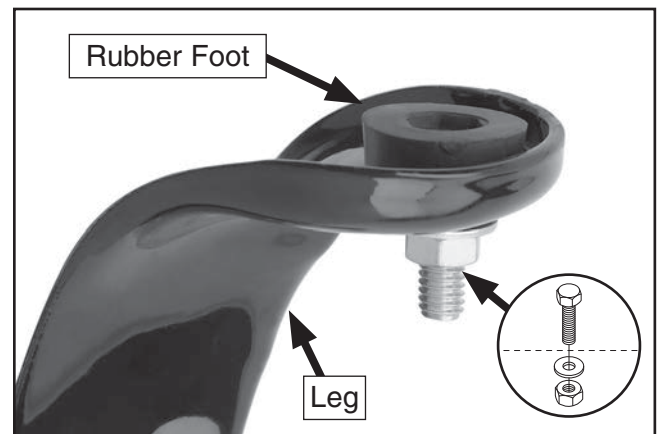

Figure 17. Foot fastened to bottom of a leg.

2. Repeat **Step 1** to install remaining feet on the other (3) legs.
3. Fasten (1) long upper and long lower brace to (2) stand legs with (8) $\frac{5}{16}$ "-18 x $\frac{1}{2}$ " carriage bolts, $\frac{5}{16}$ "-18 hex nuts, and $\frac{5}{16}$ " flat washers, as shown in **Figure 18**. Finger tighten the fasteners for now.



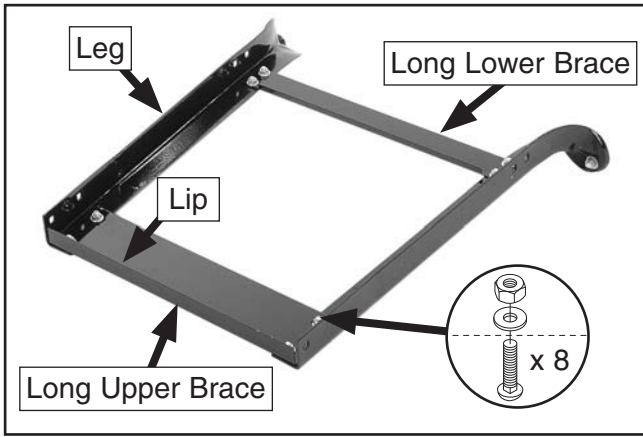

Figure 18. Stand legs fastened to long braces.

Note: Make sure the lip on the long braces faces up.

4. Repeat **Step 3** to fasten the (2) remaining long upper and long lower braces to the remaining stand legs.
5. Fasten the (2) short upper braces and the (2) short lower braces to (1) of the leg assemblies with (8) $\frac{5}{16}$ "-18 x $\frac{1}{2}$ " carriage bolts, $\frac{5}{16}$ "-18 hex nuts, and $\frac{5}{16}$ " flat washers, as shown in **Figure 19**.

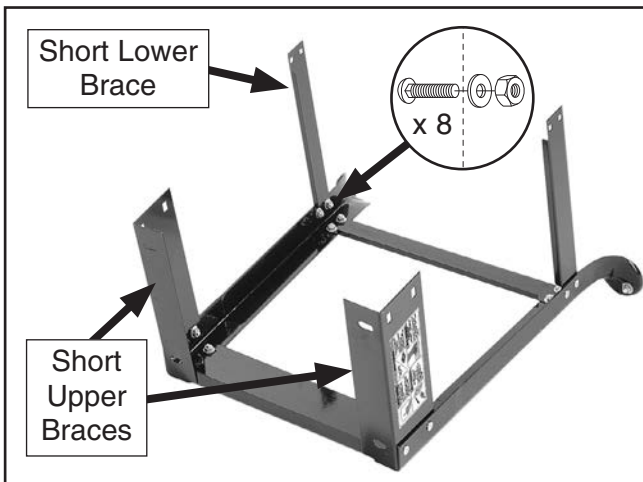

Figure 19. Short upper and lower braces fastened to leg assembly.

Note: Make sure the (2) short upper braces overlap the long upper braces and that the braces are placed inside the leg assemblies, as shown in **Figure 20**.

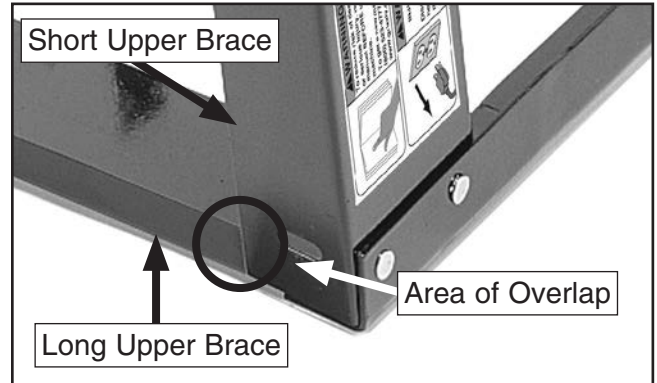

Figure 20. Short brace overlapping long upper brace.

6. Fasten the second leg assembly to the braces on the first leg assembly with the remaining (8) $\frac{5}{16}$ "-18 x $\frac{1}{2}$ " carriage bolts, $\frac{5}{16}$ "-18 hex nuts, and $\frac{5}{16}$ " flat washers, then place the stand upright on its feet, as shown in **Figure 21**.



Figure 21. Stand assembled.

7. Final tighten all the fasteners on the stand.
8. Tighten the hex nuts on the feet.



- Place a level on top of the stand (see **Figure 22**) and adjust the stand if needed by shimming the feet so it is level from front-to-back and side-to-side.



Figure 22. Leveling stand.

- Proceed to **Step 16**.

- Place the cabinet flat on its side on a flat, protected surface, but do not lay it down on the switch or door handle.

- Insert a $\frac{5}{16}$ "-18 x 1" hex bolt through the bottom of each of the four rubber feet, then insert the hex bolt on each foot into the mounting holes on the bottom of the cabinet.

- Fasten each foot with a $\frac{5}{16}$ "-18 hex nut and $\frac{5}{16}$ " flat washer (see **Figure 23**).

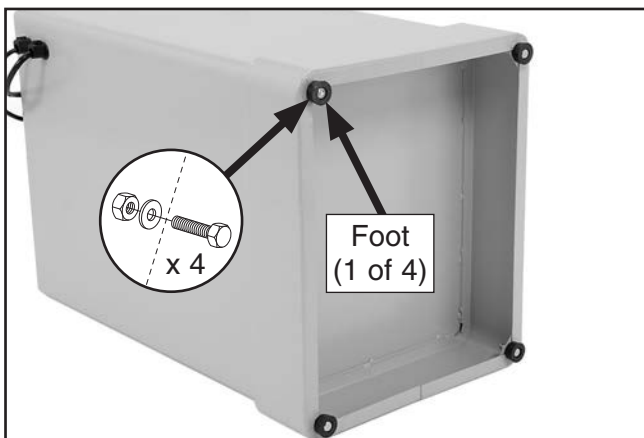

Figure 23. Feet installed onto bottom of cabinet.

- Place the stand upright on its feet, then place the shelf in the cabinet.

- Place a level on top of the cabinet (see **Figure 24**) and adjust it level from front-to-back and side-to-side by shimming it.



Figure 24. Leveling cabinet.

- With the help of an assistant, lift the sanding unit onto the stand (G1014Z) or the cabinet (G1014ZX), and align the mounting holes in the sander unit and the stand or cabinet.

Note: To access the top mounting holes inside the G1014ZX cabinet stand, open the front door.

Tip: Insert the end of the included 4mm hex wrench through the mounting holes in the sanding unit and the stand or cabinet, then jiggle the wrench back and forth to align the mounting holes.

- Secure the sanding unit to the stand or cabinet with (4) $\frac{5}{16}$ "-18 x $\frac{1}{2}$ " hex bolts and $\frac{5}{16}$ " flat washers, as shown in **Figures 25–26**.

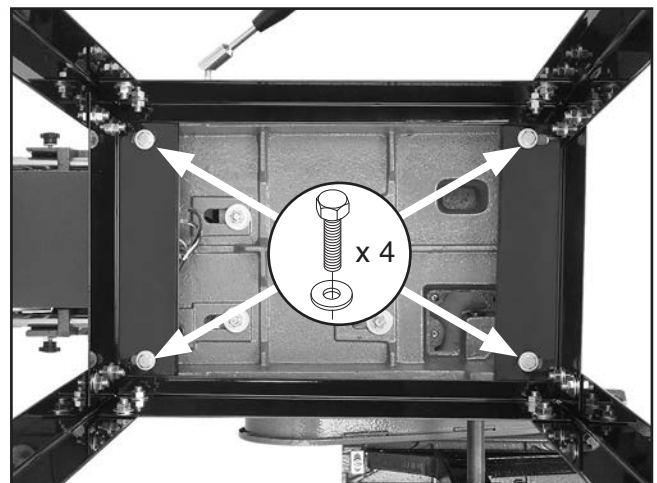

Figure 25. G1014Z sander fastened to stand (view from underneath stand).



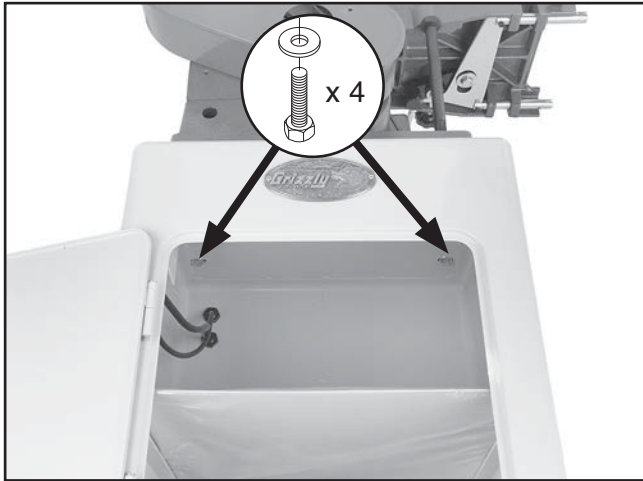

Figure 26. G1014ZX sander fastened to cabinet (2 of 4 hex bolts shown).

18. Slide the flat ends of the idler roller into the slots on the roller adjustment bars (see **Figure 27**).
19. Install (1) $\frac{1}{4}$ "-20 x $\frac{1}{2}$ " thumb knob and (1) $\frac{1}{4}$ " flat washer onto each side of sander behind idler roller (see **Figure 27**).

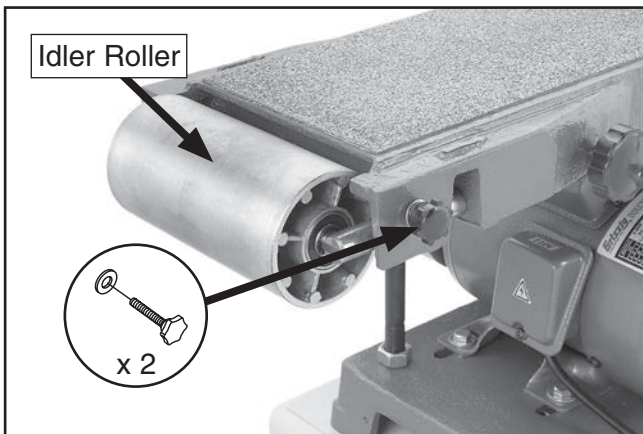

Figure 27. Idler roller installed.

20. Loosen, but do not remove, the shaft set screws on the cast iron plate so they are backed out of the shaft hole and keyway (see **Figure 28**).

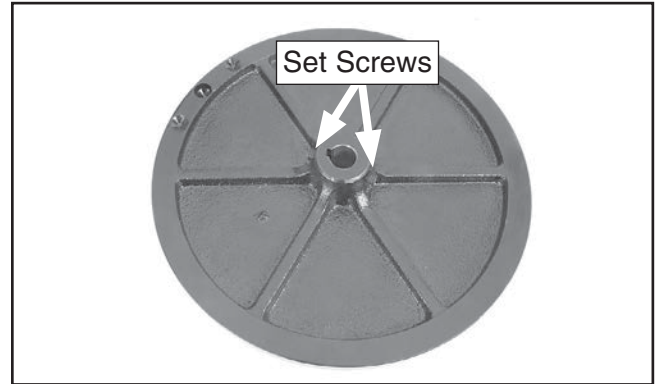

Figure 28. Set screw locations on sanding disc plate.

21. Align the keyway on the plate with the drive shaft key, then slide the plate onto the shaft, as shown in **Figure 29**.

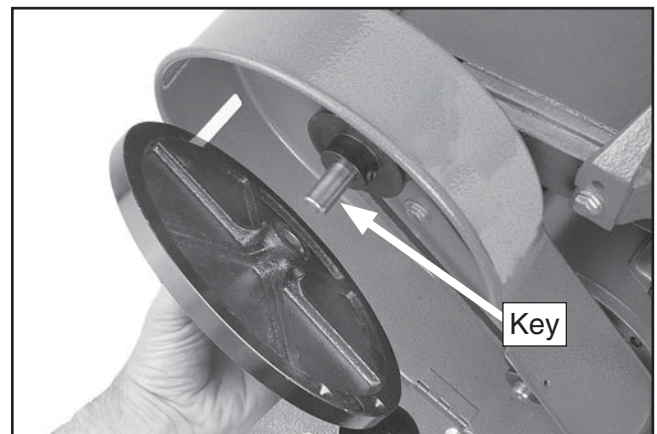

Figure 29. Installing plate onto drive shaft.

22. Adjust the cast iron plate so it protrudes slightly ($\frac{1}{16}$ "- $\frac{1}{8}$ ") beyond the curved lip of the metal cover on both sides, as illustrated in **Figure 30**, to avoid the possibility of workpieces hitting the cover during sanding operations.

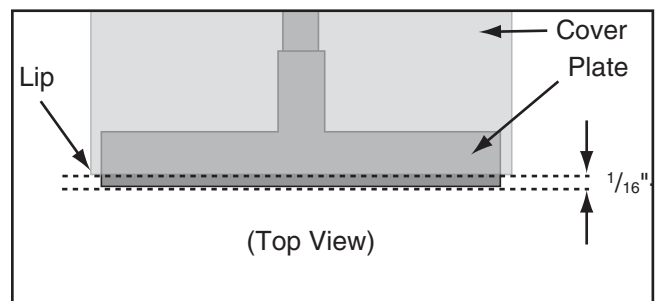

Figure 30. Gap between plate and cover.



23. While looking through the access hole on the side of the cover, rotate the plate and tighten each of the set screws to secure the plate to the drive shaft (see **Figure 31**).

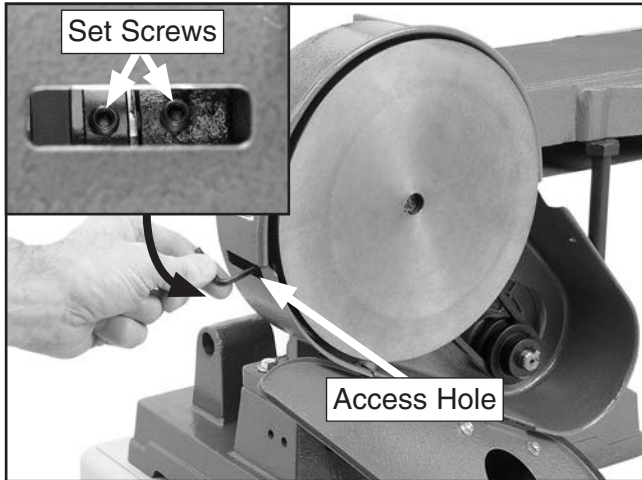

Figure 31. Securing plate to drive shaft.

24. Peel off the backing on the 9" PSA (pressure sensitive adhesive) sanding disc, make sure the cast iron plate is clean, and install the sanding disc onto the plate, as shown in **Figure 32**. Make sure the sanding disc adheres completely flat against the plate.



Figure 32. Installing sanding disc onto cast iron plate.

25. Install the 2½" black plastic dust port onto the pulley cover with (4) 10-24 x ⅜" Phillips head screws, 10-24 hex nuts, and #10 flat washers, as shown in **Figure 33**.

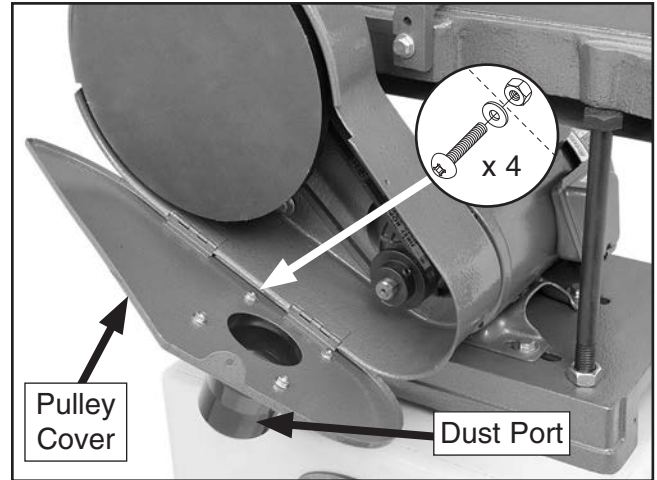

Figure 33. 2½" dust port installed.

26. Secure the pulley cover with the thumb knob.
27. Loosen the (2) set screws on the back of the base, slide the table support rod into the base, making sure the flat of the rod faces the set screws, then tighten the set screws, as shown in **Figure 34**. The rod should protrude about 6¼" from the side of the base.

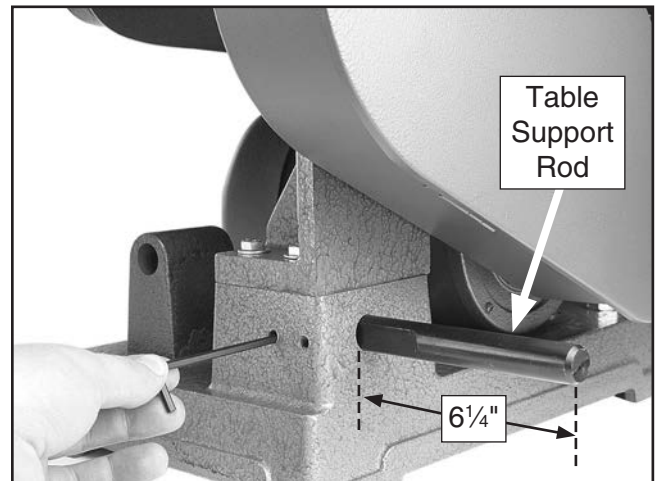

Figure 34. Installing table support rod.



28. Loosen the (2) set screws on the work table arm so their ends are flush with the inside of the opening, as shown in **Figure 35**.
29. Loosen the angle adjustment knob on the work table (see **Figure 35**), tilt the table to the 0° mark, then tighten the knob.

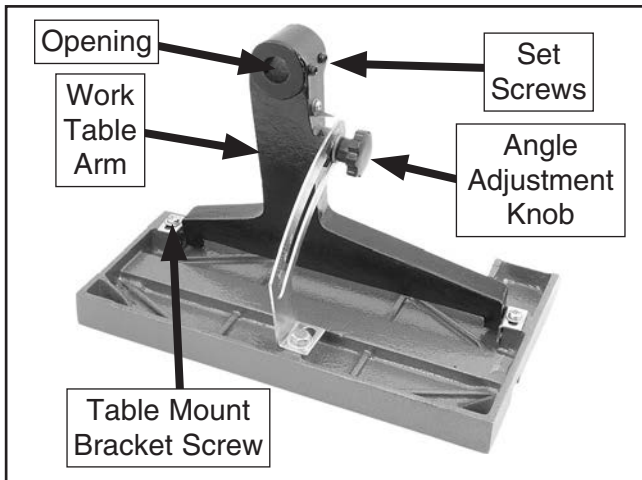

Figure 35. Location of work table installation components.

30. Slide the work table arm onto the table support rod, making sure that the set screws on the table arm face the flat part of the rod, as shown in **Figure 36**.



Figure 36. Installing work table onto table support rod.

31. Using a ruler, adjust the edge of the work table approximately $\frac{1}{16}$ " away from the sanding disc on both sides (see **Figure 37**), then tighten the set screws on the work table arm.

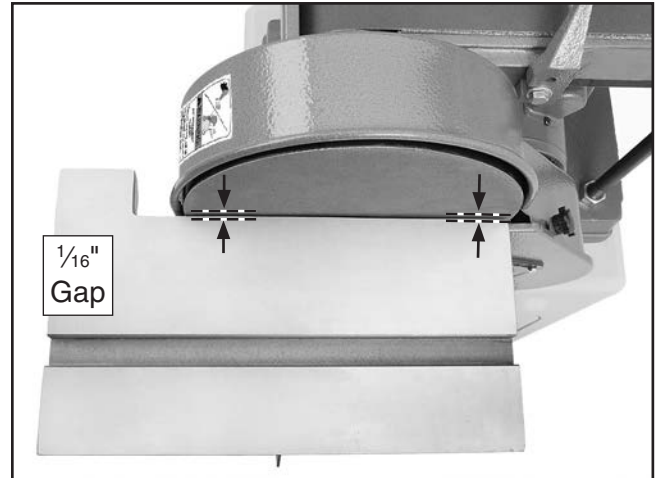

Figure 37. Correct distance between disc and work table.

- If the gap between the work table and the sanding disc is not the same on both sides, loosen one of the table mount bracket screws (see **Figure 35**), adjust the table as needed to even the gap, then tighten the screw.

⚠ CAUTION

To reduce the risk of your fingers getting stuck between the work table and sanding disc, set the table no more than $\frac{1}{16}$ " away from the sanding disc.

32. Square the table to the sanding disc (refer to instructions on **Page 47** for more details).



33. Install the 2" dust port onto the back of the sanding belt frame with the pre-installed 1/4"-20 x 1/2" hex bolts and 1/4" flat washers, as shown in **Figure 38**.

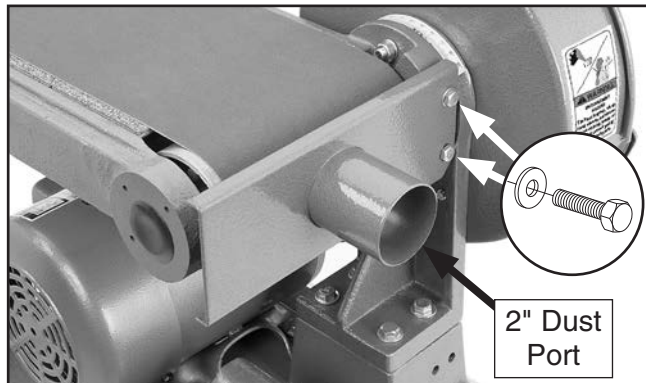

Figure 38. 2" dust port installed.

34. Assemble the quick release lever, as shown in **Figure 39**, using the handle, 6" quick release lever stud, short lever arm, and (2) 3/8"-16 hex nuts.

35. Thread the assembly from **Step 34** into the rocker arm, then tighten the hex nuts (see **Figure 39**).

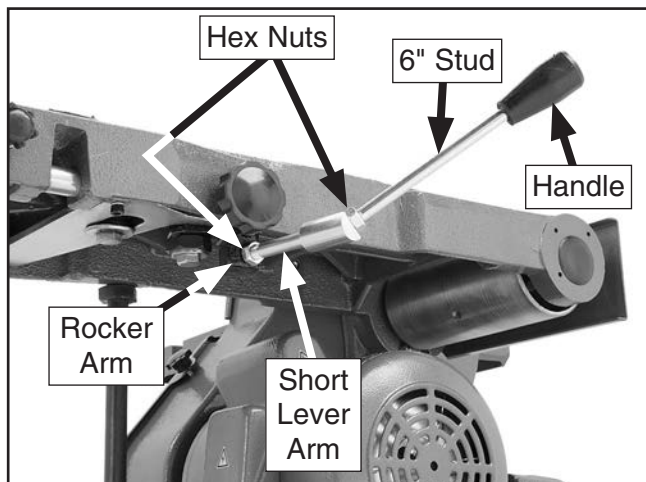

Figure 39. Quick release lever installed.

36. Move the quick release lever toward the motor, slide the sanding belt over the lever and onto the idler roller and drive rollers, then center the belt on the rollers (see **Figure 40**).

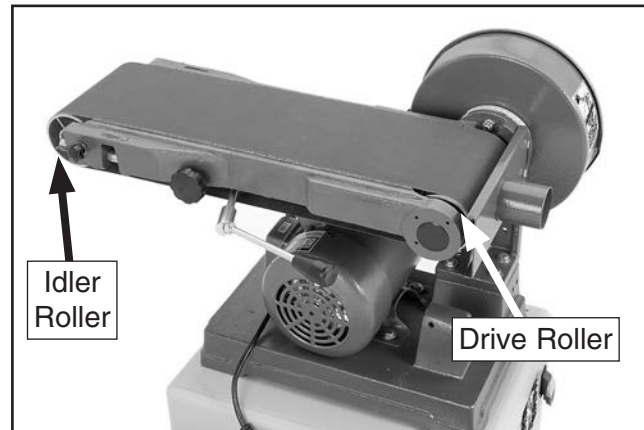

Figure 40. Belt installed onto idler and drive rollers.

37. Push the lever toward the motor to tension the sanding belt.

38. Assemble idler roller guard with (2) M5-.8 x 10 thumb knobs, #10 lock washers, and #10 flat washers, then loosen thumb knobs behind idler roller, and install idler roller assembly (see **Figure 41**).

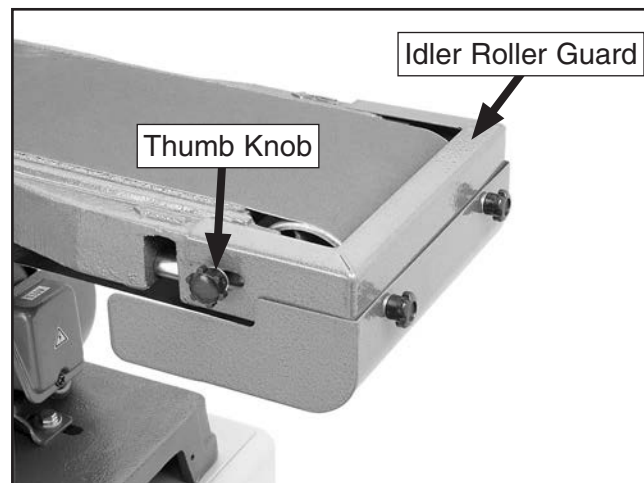

Figure 41. Idler roller guard installed.



39. Adjust the inside edge of the idler roller guard $\frac{1}{4}$ "- $\frac{1}{2}$ " away from the sanding belt (see **Figure 42**).

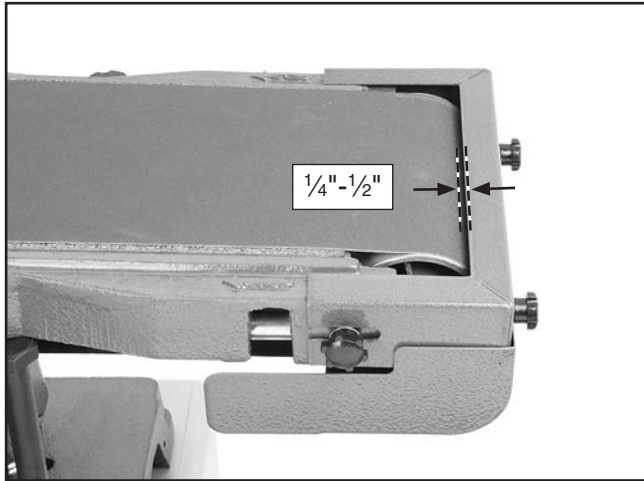

Figure 42. Correct distance between belt and idler roller guard.

40. Rotate the sanding belt just enough to verify that the belt does not catch on or rub against the ends of the thumb screws on the sleeve guard.
41. Tighten the thumb knobs located behind the idler roller to secure the guard.
42. **G1014ZX Only:** Connect the motor cord to the power cord on the cabinet (see **Figure 43**). **DO NOT** connect the sander to the power until indicated in the **Test Run** section on **Page 30**.

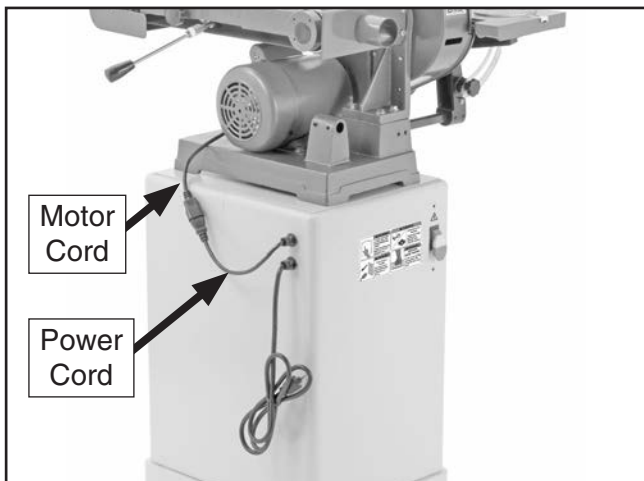

Figure 43. Motor cord connected to power cord.

43. To set up the sanding belt in the vertical position, follow the instructions on **Page 36**.
44. Loosen the pre-installed $\frac{5}{16}$ "-18 x 1" hex bolt and flat washer on the side of the sanding belt frame, slide the back stop groove onto the bolt, then finger tighten the bolt.
45. Place a machinist's square flat against the sanding belt and back stop (see **Figure 44**) adjust the back stop flush with the square on both sides of the belt and $\frac{1}{16}$ " above the belt (see **Figure 45**), then tighten the hex bolt.

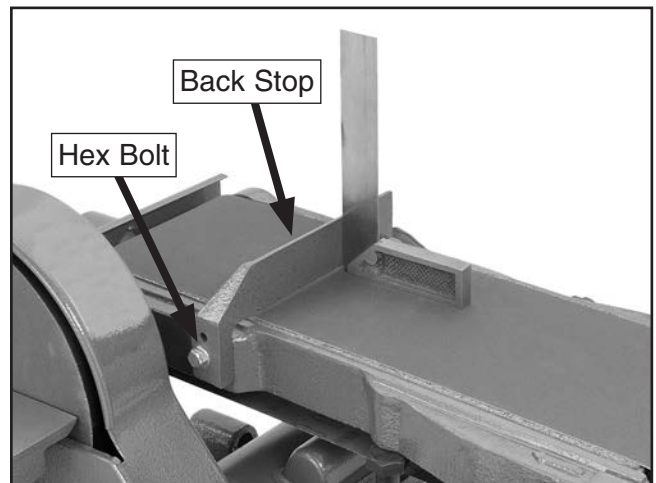

Figure 44. Adjusting back stop square to belt.

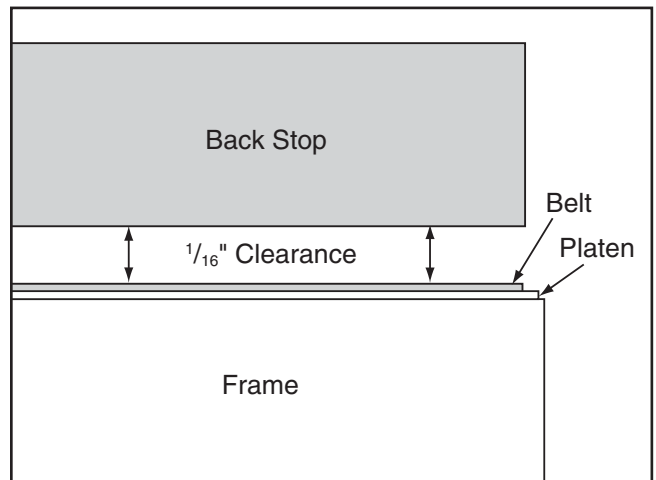

Figure 45. Correct clearance between back stop and belt.



46. Place one edge of a machinist's square against the face of the miter gauge and the other against the sanding disc (see **Figure 46**) or sanding belt.

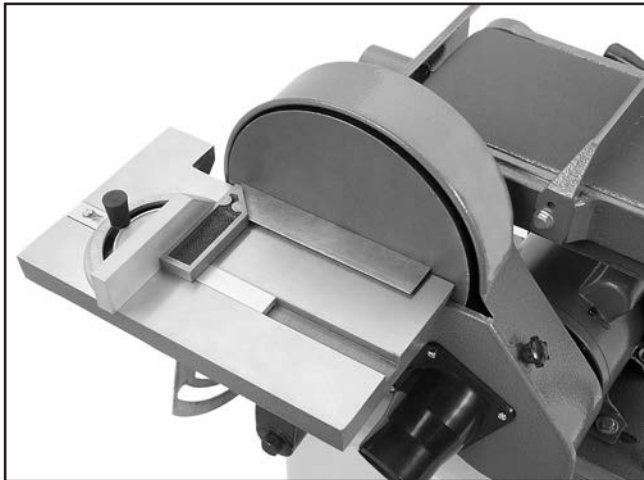

Figure 46. Calibrating miter gauge with square.

47. Loosen the lock knob on the miter gauge and adjust it flush with the edge of the square.

48. Tighten the lock knob and verify the setting.

Note: *Sometimes the tightening procedure can affect the adjustment.*

49. Loosen the screw that secures the angle pointer and adjust the pointer to the 0° mark on the scale.

50. Retighten the screw that secures the angle pointer.

51. Repeat **Steps 46–50** in a similar manner to calibrate the miter gauge to the belt if you set up the sander for vertical sanding.

Pre-Tracking Belt

You must perform the following procedure before the test run to ensure that the belt does not come off or get jammed against the sanding belt frame.

To pre-track the belt:

1. DISCONNECT MACHINE FROM POWER!
2. Loosen the lock nut on the tracking control knob (see **Figure 4** on **Page 4**), then move the quick release tension lever to the tensioned position.

⚠ CAUTION

Moving sanding belts are dangerously abrasive. Use extreme caution when working near sanding surfaces.

3. Standing in front of the sander, carefully push the sanding belt multiple times along the platen, so that it moves in the direction of operation (clockwise on the rollers), then watch how the belt tracks on the rollers.
4. Adjust the tracking with the tracking control knob and continue to rotate the belt by hand until the sanding belt is centered on the main roller, as shown in **Figure 47**.

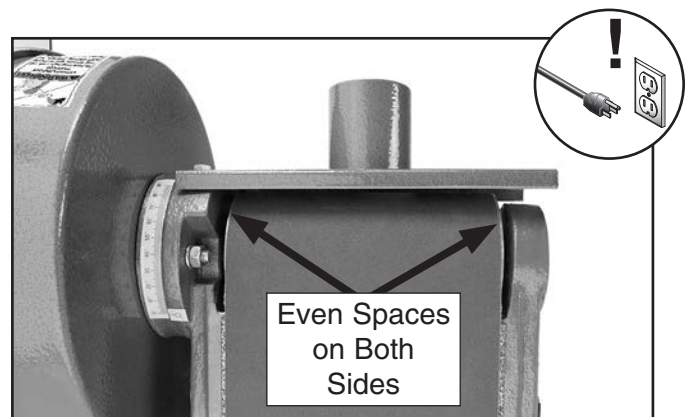

Figure 47. Example of sanding belt centered on main roller.

5. Tighten the tracking control knob lock nut.



Dust Collection

⚠ CAUTION

This machine creates a lot of wood chips/dust during operation. Breathing airborne dust on a regular basis can result in permanent respiratory illness. Reduce your risk by wearing a respirator and capturing the dust with a dust-collection system.

Recommended CFM at 2" Dust Port: 100
Recommended CFM at 2½" Dust Port: 150

Do not confuse this CFM recommendation with the rating of the dust collector. To determine the CFM at the dust port, you must consider these variables: (1) CFM rating of the dust collector, (2) hose type and length between the dust collector and the machine, (3) number of branches or wyes, and (4) amount of other open lines throughout the system. Explaining how to calculate these variables is beyond the scope of this manual. Consult an expert or purchase a good dust collection "how-to" book.

The Model G1014Z/G1014ZX features a 2" dust port and a 2½" dust port that can be connected to a dust collector or a dust collection system, using the components shown in **Figure 48**.

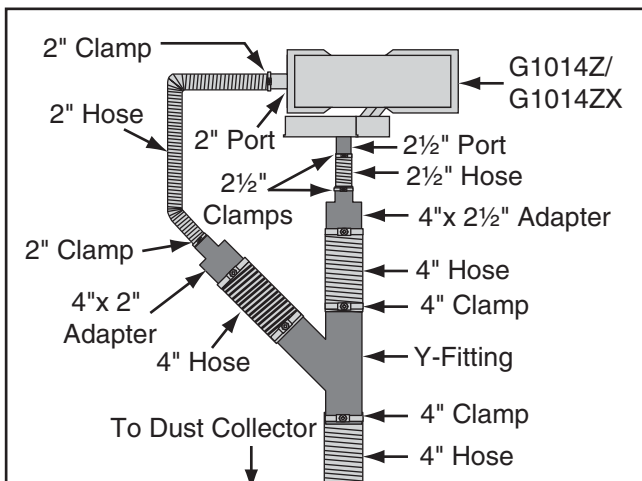

Figure 48. Sander hooked up to 4" hose.

Figure 49 shows a 2" dust hose connected to the dust collection port with a hose clamp.

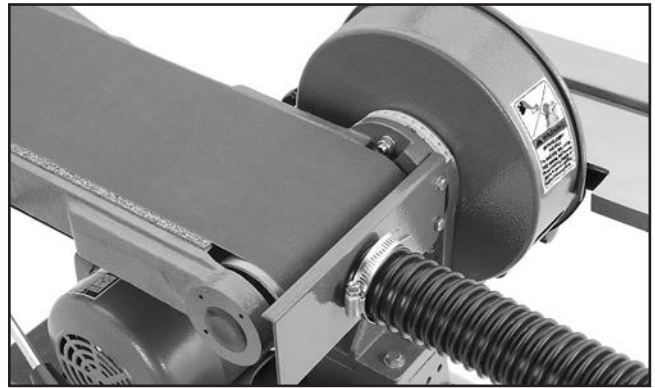

Figure 49. Hose attached to 2" dust port.

Note: A tight fit is necessary for proper performance.

Figure 50 shows a 2½" dust hose attached to the dust port with a hose clamp. After installing the dust hoses on the two ports, tug the hoses to make sure they do not come off.

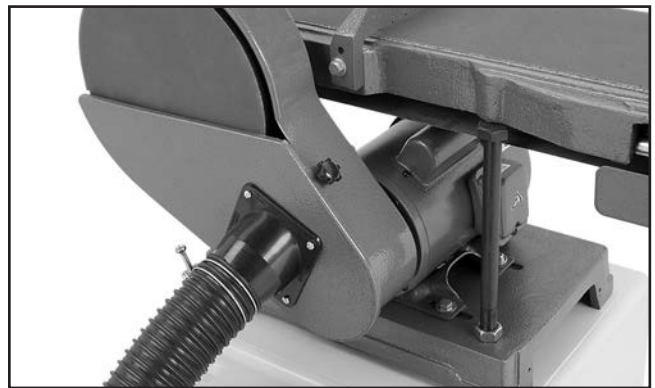

Figure 50. Hose attached to 2½" dust port.

You can also attach a wet/dry vacuum with a 2¼" outside diameter hose to the sander. The hose will slide into the 2½" dust port or fit over the 2" dust port.



Test Run

Once assembly is complete, test run the machine to ensure it is properly connected to power and safety components are functioning correctly.

If you find an unusual problem during the test run, immediately stop the machine, disconnect it from power, and fix the problem BEFORE operating the machine again. The **Troubleshooting** table in the **SERVICE** section of this manual can help.

The Test Run consists of verifying the following: 1) The belt tracks properly and will not come off the rollers during initial startup, 2) the motor powers up and runs correctly, and 3) the switch disabling key disables the switch properly.

!WARNING

Serious injury or death can result from using this machine BEFORE understanding its controls and related safety information. DO NOT operate, or allow others to operate, machine until the information is understood.

!WARNING

DO NOT start machine until all preceding setup instructions have been performed. Operating an improperly set up machine may result in malfunction or unexpected results that can lead to serious injury, death, or machine/property damage.

To test run the machine:

1. Clear all setup tools away from machine.
2. Tie back loose clothing and long hair to protect yourself from getting caught in the moving belt and disc when you start the machine.
3. Connect the machine to the power source.

!CAUTION

Moving sanding belts are dangerously abrasive. Use extreme caution when working near sanding surfaces.

4. Verify that the machine is operating correctly by turning it **ON**. Be ready to turn it **OFF** if it tracks over the sanding belt frame edge. The motor should run smoothly and without unusual problems or noises.
 - If the motor *does not* run smoothly, turn the machine **OFF** and disconnect power. Contact technical support.
5. Loosen the lock nut on the tracking control knob, and carefully adjust the tracking in small increments until the sanding belt remains centered on the main roller (see **Figure 47, Page 28**).
6. When the tracking is correct, allow the sander to run for approximately one minute to verify that the tracking stays in the correct position.
7. When the sanding belt is tracking correctly, tighten the lock nut on the tracking control knob.
8. Turn the machine **OFF**, and remove the switch disabling key, as shown in **Figure 51**.

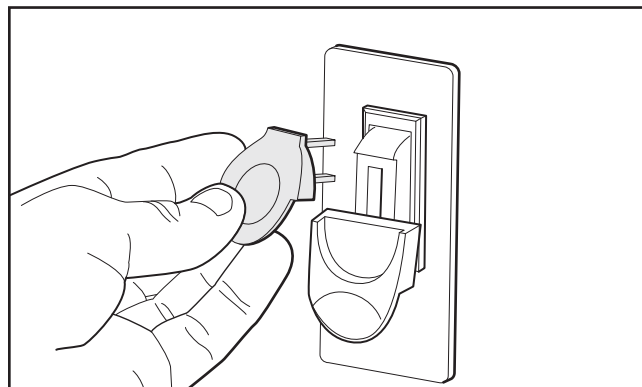

Figure 51. Removing switch key from paddle switch.

9. Try to turn the start the sander with the paddle switch.
 - If the sander does not start, the switch disabling feature is working as designed.
 - If the sander starts, immediately stop the machine. The switch disabling feature is not working correctly. This safety feature must work properly before proceeding with regular operations. Call Tech Support for help.





SECTION 4: OPERATIONS

Operation Overview

The purpose of this overview is to provide the novice machine operator with a basic understanding of how the machine is used during operation, so the machine controls/components discussed later in this manual are easier to understand.

Due to the generic nature of this overview, it is **not** intended to be an instructional guide. To learn more about specific operations, read this entire manual, seek additional training from experienced machine operators, and do additional research outside of this manual by reading "how-to" books, trade magazines, or websites.

	!WARNING To reduce your risk of serious injury, read this entire manual BEFORE using machine.
--	--

!WARNING To reduce risk of eye injury from flying chips or lung damage from breathing dust, always wear safety glasses and a respirator when operating this machine.	
	

	!WARNING Keep hair, clothing, and jewelry away from moving parts at all times. Entanglement can result in death, amputation, or severe crushing injuries!
---	---

NOTICE

If you are not experienced with this type of machine, **WE STRONGLY RECOMMEND** that you seek additional training outside of this manual. Read books/magazines or get formal training before beginning any projects. Regardless of the content in this section, Grizzly Industrial will not be held liable for accidents caused by lack of training.

To complete a typical operation, the operator does the following:

1. Examines the workpiece to make sure it is suitable for sanding.
2. Inspects and installs a sanding belt/disc with appropriate the grit for the operation.
3. **For sanding on the belt:** Adjusts the platen tilt as desired (and the table/miter gauge, if used).

For sanding on the disc: Adjusts the table tilt and/or the miter gauge position to the desired location.

4. Secures any loose clothing, removes loose jewelry, and ties back long hair.
5. Puts on some safety glasses and a respirator. Takes all other required safety precautions.
6. Starts the dust collector, then turns the sander **ON**.
7. Holds the workpiece firmly against the back stop or the table and miter gauge (if used), pushes the workpiece into the sanding belt or along the down-spin of sanding disc, and moves the workpiece back and forth to wear the sandpaper evenly and prevent overheating.
8. Turns the sander **OFF**, then stops the dust collector.



Sanding Tips

- Extend the life of the sandpaper by regularly using PRO-STIK® abrasive belt cleaners (see **Accessories** on **Page 42**).
- When sanding workpieces with a bow or crown, place the high point up on the able to prevent the workpiece from rocking, then take very light passes.
- Hold workpiece securely with both hands and do not wear gloves. Use work table, miter gauge, and back stop whenever possible to support workpiece. Do not force workpiece against belt or disc.
- Sanding discs/belts clog and wear. Change sandpaper whenever you notice a difference in sanding quality/performance.
- To increase the life of the sanding disc/belt and ensure even wear, move the workpiece back and forth across the sanding surface.
- As a rule-of-thumb, sand with progressively higher grit numbers. A higher grit will achieve a finer finish.
- Make sure sanding belt and V-belt covers are closed and secured during operation.
- Avoid sanding a workpiece more than is necessary, since doing so will unnecessarily decrease belt life and cost you more money over time.

CAUTION

A moving belt or disc can cause serious personal injury if it comes in contact with your fingers, hands, or other body parts. Always support the workpiece against the table, back stop, or miter gauge when sanding. Use extreme care to provide a safe distance between sanding paper and any body part.

Choosing Sandpaper

The Model G1014Z/G1014ZX uses a 6" x 48" sanding belt and a 9" sanding disc. Below is a chart that groups abrasives into different classes, and shows which grits fall into each class.

Grit	Class	Usage
36	Extra Coarse	Rough sawn boards, thickness sanding, and glue removal.
60	Coarse	Thickness sanding and glue removal.
80–100	Medium	Removing marks and initial finish sanding.
120–180	Fine	Finish sanding.

We recommend using aluminum-oxide sanding belts and discs for best results. The grit you choose will depend on the condition and species of wood, and the level of finish you wish to achieve.

The general rule of thumb is to sand a workpiece with progressively higher grit numbers. Avoid skipping grits; the larger the grit increase at one time, the harder it will be to remove the scratches from the previous grit.

Ultimately, the type of wood you use and your stage of finish will determine the best grit types to install on your sander.

Note: Sandpaper finer than 180-grit will easily load up or burn workpieces.



Workpiece Inspection

Some workpieces are not safe to sand or may require modification before they are safe to sand.

Before sanding, inspect all workpieces for the following:

- **Material Type:** This machine is intended for sanding natural and man-made wood products. This machine is NOT designed to sand metal, glass, stone, tile, plastics, drywall, cement backer board, laminate products, etc. Sanding improper materials increases risk of respiratory harm to operator and bystanders due to especially fine dust inherently created by all types of sanding operations—even if a dust collector is used. Additionally, life of machine and sanding belts/discs will be greatly reduced (or immediately damaged) from sanding improper materials or from exposure to fine dust created when doing so.
- **Foreign Objects:** Nails, staples, dirt, rocks and other foreign objects are often embedded in wood. While sanding, these objects can become dislodged and tear sanding belt or disc. Always visually inspect your workpiece for these items. If they cannot be removed, DO NOT sand the workpiece.
- **Wet or "Green" Stock:** Sanding wood with a moisture content over 20% causes unnecessary clogging and wear on the sanding belt or disc, increases the risk of kickback, and yields poor results.
- **Excessive Glue or Finish:** Sanding workpieces with excess glue or finish will load up the abrasive, reducing its usefulness and lifespan.

Horizontal & Edge Sanding

If the sanding belt frame is in the vertical position, proceed to **Setting Up Sander for Horizontal and Edge Sanding** below to setup the sander for horizontal sanding. If the sander is already in the horizontal position, skip ahead to **Performing Horizontal Sanding and Edge Sanding**.

Setting Up Sander for Horizontal and Edge Sanding

1. Loosen the set screws that secure the work table support rod to the mounting bracket behind the motor, then remove the work table assembly (see **Figure 52**).



Figure 52. Location for removing work table assembly.



- Loosen the sanding frame rotation lock nuts (behind the sanding disc cover), rotate the frame to the horizontal position, as shown in **Figure 53**, then tighten the rotation lock nuts.

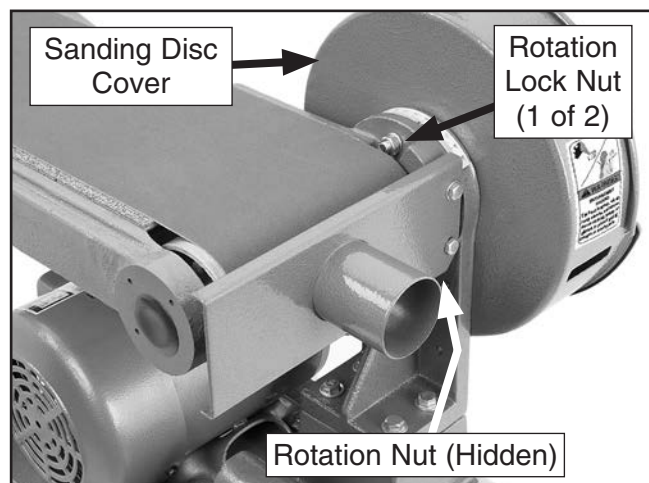

Figure 53. Table tilted to horizontal position.

- Insert the table support rod into the hole in the base under the sanding disc, and position the work table $\frac{1}{16}$ " away from the sanding disc, as shown in **Figures 36–37** on **Page 25**.
- Check that the miter gauge slot-sanding disc distance is correct (see instructions on **Page 48** for further detail).
- Install the back stop so it is square with and $\frac{1}{16}$ " above the sanding belt (see **Figure 44** on **Page 27**).

Performing Horizontal and Edge Sanding

- Use quick release tension lever to tension sanding belt.
- Make sure the belt tracking is correctly set (see **Tracking Belt** on **Page 41**).
- Turn the sander **ON**.

- While holding the back end of the workpiece against the back stop with both hands, and while keeping your fingers away from the belt, slowly feed the workpiece into the belt, as shown in **Figures 54–55**.

Note: Apply even pressure and move the workpiece back and forth across the sanding belt.



Figure 54. Sanding workpiece in horizontal position.



Figure 55. Sanding edge of workpiece in horizontal position.

!WARNING

Sanding surfaces can cause serious personal injury if they come in contact with fingers, hands or other body parts. Use extreme care to provide a safe distance between the belt and any part of your body.



Contour Sanding

Contour sanding operations can be performed directly on the idler roller. Since the back stop cannot be used for these operations, support the workpiece against your workbench, if the workpiece is large enough. Always use two hands to control the workpiece.

To perform contour sanding:

1. Use quick release tension lever to tension sanding belt and refer to **Tracking Belt** on **Page 41** to make sure belt is tracking correctly.
2. Loosen the knobs that secure the idler roller guard and sleeve guard assembly, then remove the guard.
3. Turn the sander **ON**.

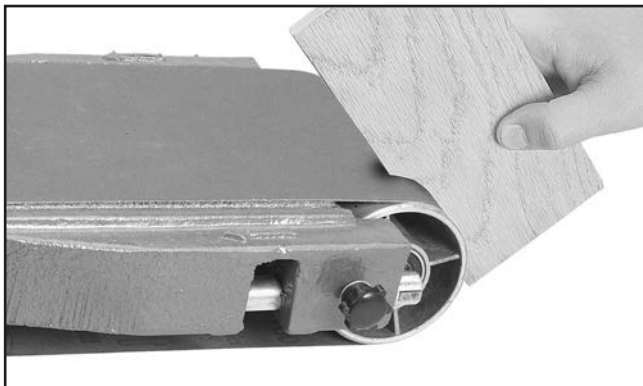

Figure 56. Example of contour sanding.

4. Slowly feed the workpiece into the curved end of the belt and continue moving the workpiece profile along the contour until you achieve your desired shape, as shown in **Figure 56**.

!WARNING

Do not operate this machine when wearing loose clothing, gloves, neckties, or jewelry that might get caught in the moving belt. Serious injury may result. You must re-install the idler roller guard before performing edge or horizontal sanding operations.

5. Install the idler roller guard.

Model G1014Z/G1014ZX (Mfd. Since 08/22)



Disc Sanding

The sanding disc can be used to create flat, smooth ends and edges of workpieces.

!CAUTION

To reduce the risk of your fingers getting trapped between the work table and sanding disc, make sure the table is no more than $\frac{1}{16}$ " away from the sanding disc.

!CAUTION

Always keep the workpiece on the left side of the wheel that rotates down toward the work table. This will keep the workpiece from flying out of your hands due to kick-back.

To use the sanding disc:

1. DISCONNECT MACHINE FROM POWER!
2. Adjust the angles of the work table and the miter gauge for your operation.
3. Connect the sander to power, turn it **ON**, and allow it to reach full speed.
4. Place the workpiece on the work table and firmly against the miter gauge.
5. With light pressure, slowly move the workpiece into the left side of the sanding disc. See **Figures 57–60** for examples of disc sanding.



Figure 57. Example of 90° disc sanding.

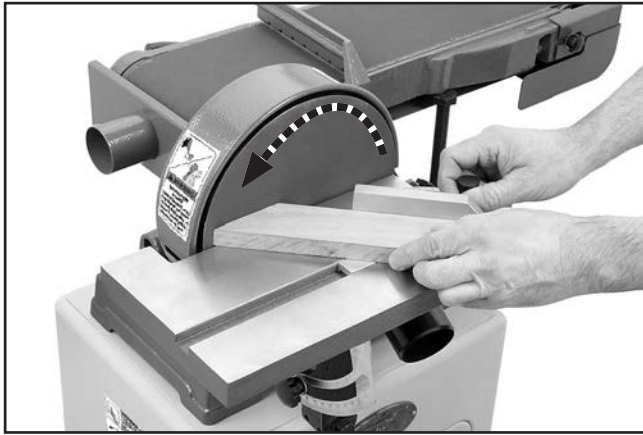

Figure 58. Example of miter sanding.

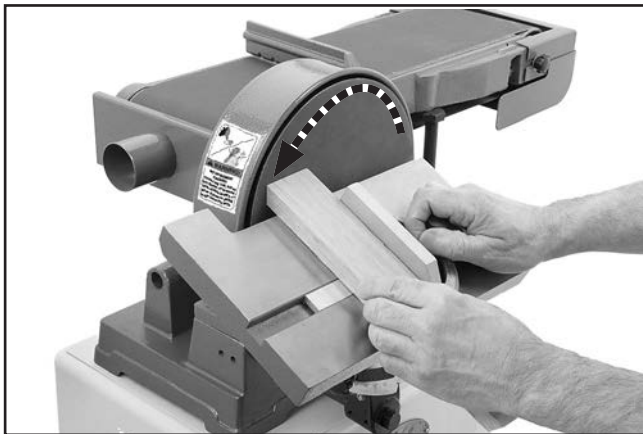

Figure 59. Example of angle sanding.



Figure 60. Example of sanding round workpiece.

Note: To prevent burning the workpiece and overloading the sanding disc, move the workpiece slowly back and forth from the left side of the sanding disc to the center.

Vertical Sanding

If the sanding belt frame is in the horizontal position, proceed to **Setting up Sander for Vertical Sanding**. If the sander is already in the vertical position, skip to **Performing Vertical Sanding** on **Page 38**.

Setting Up Sander for Vertical Sanding

1. Make sure the sanding belt is tensioned—if it is not already tight.
2. Make sure the belt tracking is correctly set (see **Tracking Belt** on **Page 41**).
3. **DISCONNECT MACHINE FROM POWER!**
4. Remove the back stop and miter gauge from the work table.
5. Loosen the sanding frame rotation lock nuts (behind the sanding disc cover) as shown in **Figures 61–62**.

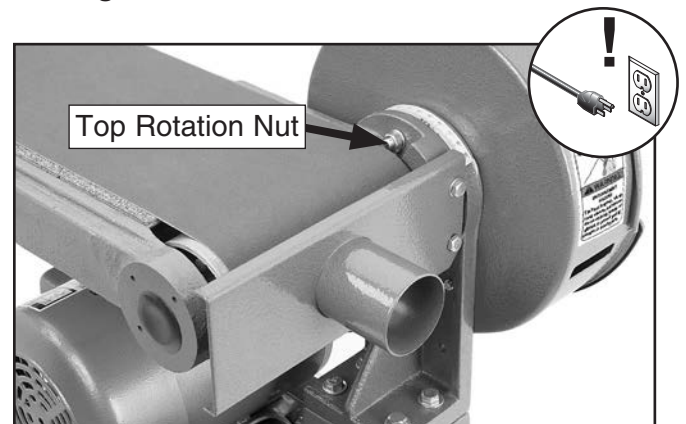

Figure 61. Location of top rotation lock nut.

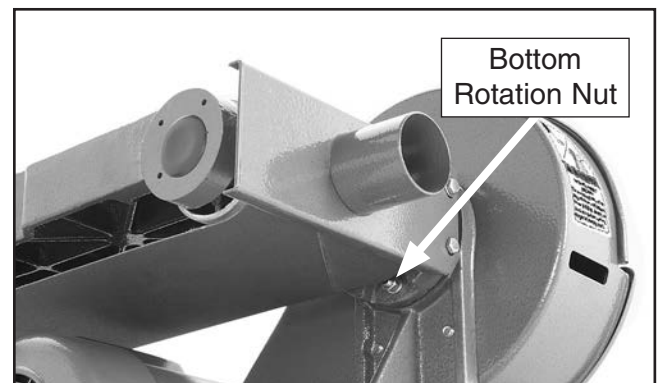

Figure 62. Location of bottom rotation lock nut.



6. Raise the sanding belt frame until it reaches the 90° mark (or the desired angle) on the tilt scale, as shown in **Figure 63**, then tighten the rotation lock nuts.

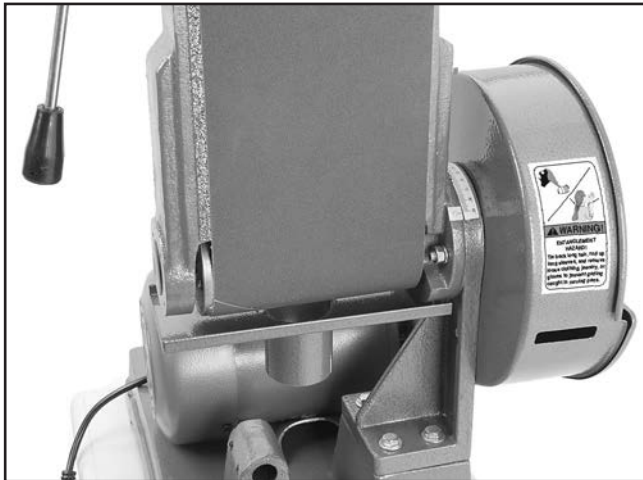

Figure 63. Sanding belt tilted to 90° position.

7. Loosen the set screws that secure the table support rod under the sanding disc, then remove the support rod and work table assembly.
8. Loosen the set screws on the mounting bracket behind the motor, then slide the support rod and work table assembly into the bracket hole, as shown in **Figure 64**.

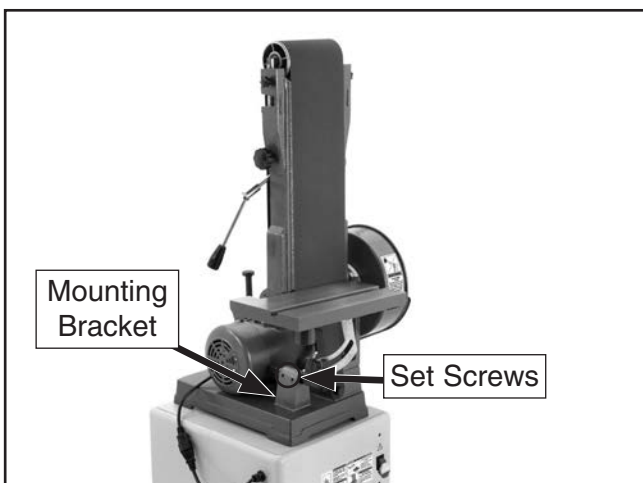

Figure 64. Work table installed for vertical sanding.

9. Adjust the front of the work table 1/16" away from the sanding belt (see **Figure 65**) across its entire length.

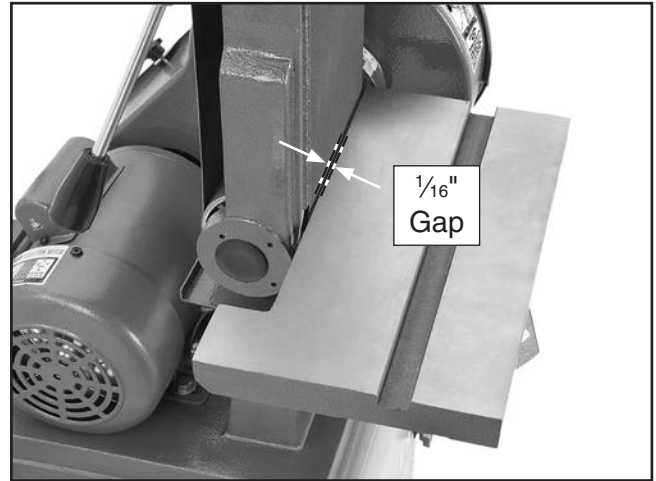

Figure 65. Correct distance between work table and sanding belt.

- If the gap is not 1/16" across the entire length of the work table, loosen one or both of the screws under the table (see **Figure 66**), where the arm is attached to the table, and adjust the table until the distance is correct, then tighten the screws.

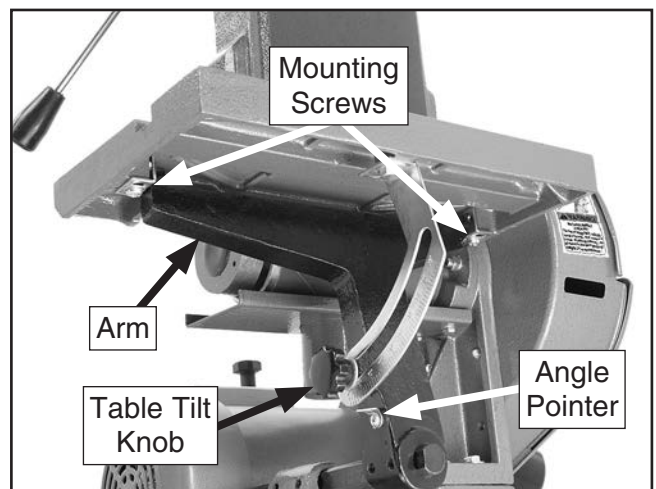

Figure 66. Location of work table arm mounting screws.

Note: To reduce the chance of vibration or rattling sounds, make sure the table support rod does not touch the motor.

10. Tighten the mounting bracket set screws to secure the support rod.



11. Place a machinist's square on the work table and against the sanding belt, as shown in **Figure 67**, and check for gaps between the square, belt, and table.



Figure 67. Squaring table and sanding belt.

— If there are any gaps, loosen the table tilt knob, adjust the table as needed to remove the gaps, then tighten the knob. Loosen the angle pointer screw, position the pointer over the zero mark on the scale, then tighten the screw.

12. Insert the miter gauge into the left side of the miter slot.

Performing Vertical Sanding

1. Adjust the angles of the work table and miter gauge for your operation.
2. Place the workpiece on the table and firmly against the miter gauge.
3. Slowly and with light pressure, move the workpiece into the left side of the sanding belt. See **Figures 68–71** for examples of horizontal belt sanding.



Figure 68. Example of end grain sanding.

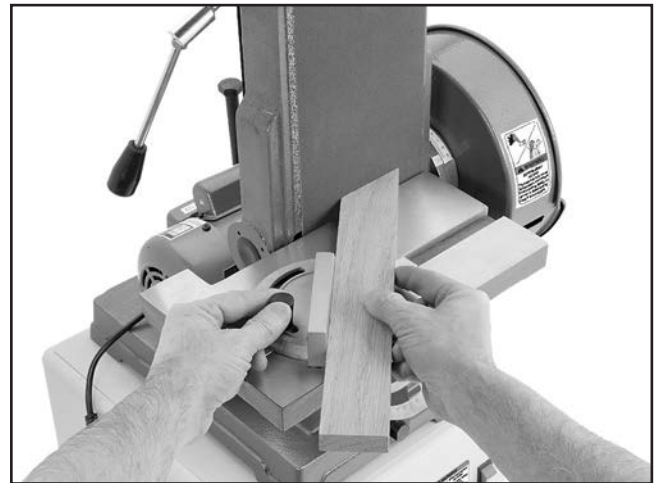

Figure 69. Example of vertical miter sanding.

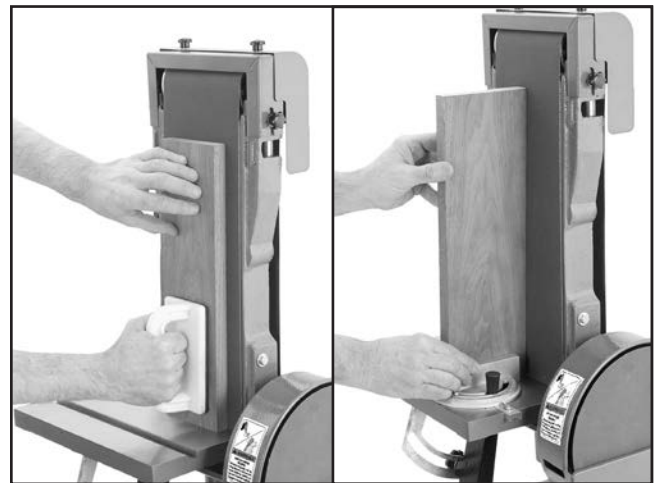

Figure 70. Example of vertical face and edge sanding.

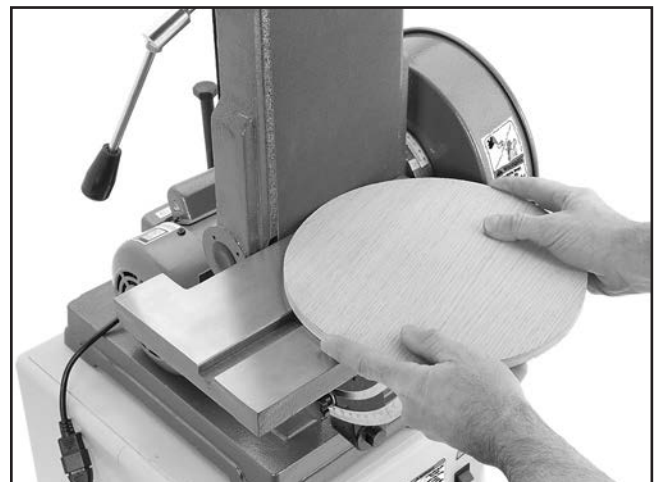

Figure 71. Example of sanding round workpiece in vertical position.



Changing Sanding Belt

Some sanding belts are designed to sand in only one direction and will have a direction indicated on the back of the belt. The Model G1014Z/G1014ZX is designed so that the sanding belt travels clockwise as viewed from the side with the quick release tension lever.

To change the sanding belt:

1. DISCONNECT MACHINE FROM POWER!
2. Move the quick release lever away from the motor to release the belt tension.
3. Remove the idler roller guard and back stop.
4. Remove the belt from the rollers and sanding belt frame.
5. Install a new sanding belt onto the idler and drive rollers, making sure the arrows on the bottom of the belt face the front of the sander, as shown in **Figure 72**.

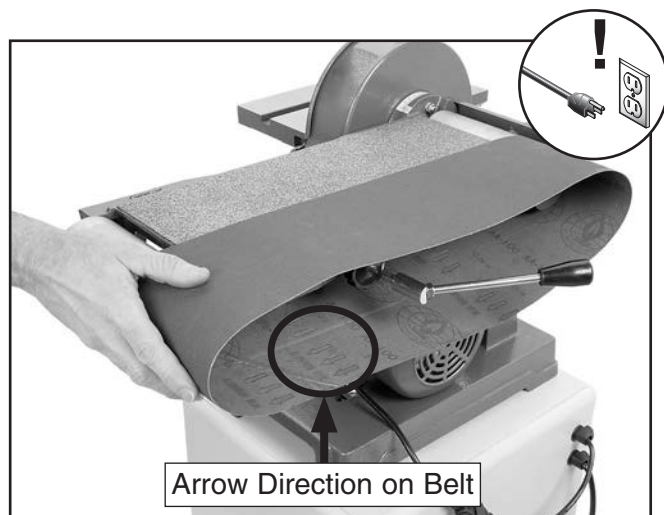

Figure 72. Installing new sanding belt.

6. Position the belt in the center of the roller, then move the quick release tension lever toward the motor to tension the belt (see **Figure 73**).

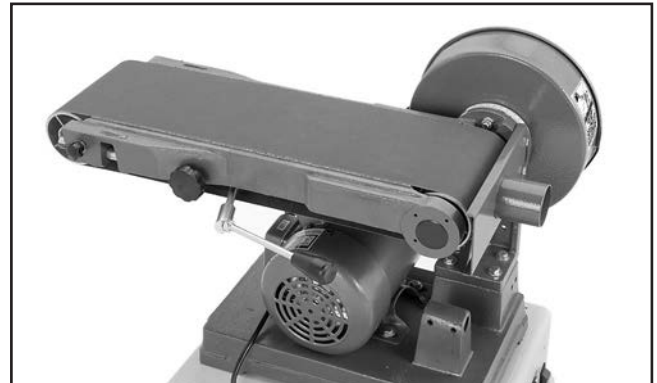

Figure 73. New belt installed.

7. Adjust the sanding belt tension for new belt (refer to **Adjusting Sanding Belt Tension** on **Page 40**).
8. Install the back stop and adjust it so it is no more than $\frac{1}{16}$ " above the belt (see **Figure 74**).

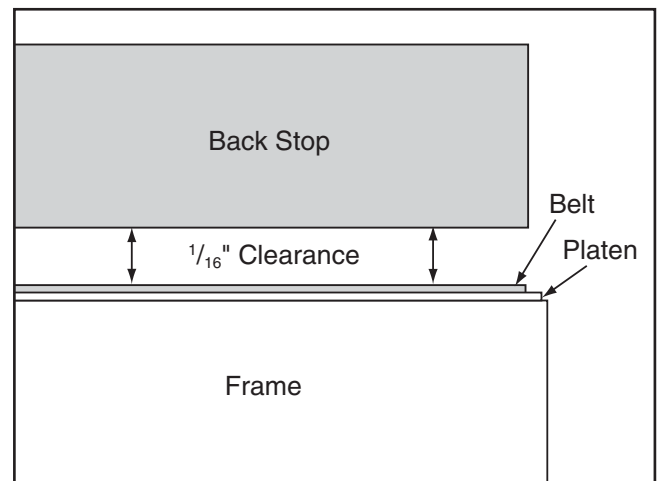

Figure 74. Correct clearance between back stop and belt.

9. Perform the belt pre-tracking procedure (refer to **Pre-Tracking Belt** on **Page 28**).
10. Perform the belt tracking procedure outlined in **Tracking Belt** on **Page 41**.



Adjusting Sanding Belt Tension

Correct belt tension will ensure that your sander functions properly. If the sanding belt slaps against the platen or slips on the idler and drive rollers, the belt may be too loose.

If you are replacing a worn sanding belt with a new one, the belt tension will likely need to be loosened.

Tools Needed	Qty
Wrench 14mm	1
Adjustable Wrench w/1½" Throat	1

To adjust sanding belt tension:

1. DISCONNECT MACHINE FROM POWER!
2. Move the quick release tension lever toward the motor to tighten the sanding belt.
3. Turn the eccentric shown in **Figure 75** to tighten or loosen the belt.

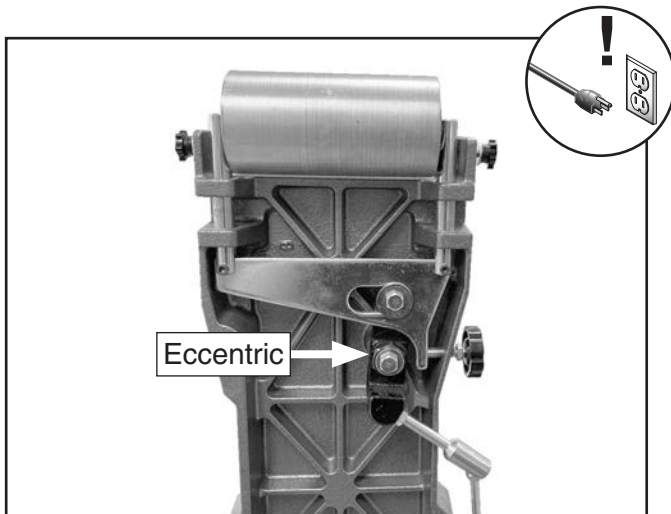

Figure 75. Location of belt tension eccentric (belt removed for clarity).

4. Push the belt in the center with your finger using moderate pressure. The deflection is correct when the belt deflects ½", as shown in **Figure 76**.

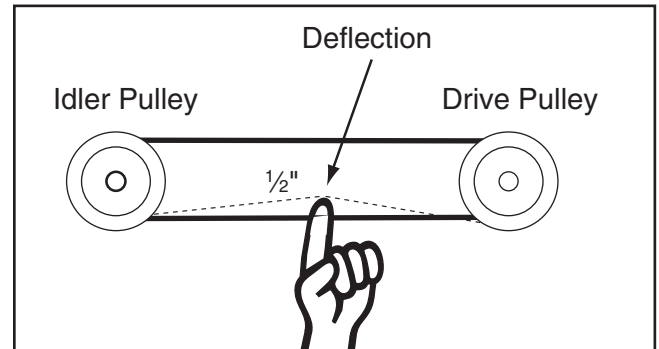

Figure 76. Checking sanding belt tension.

5. Follow the **Pre-Tracking Belt** instructions on **Page 28**.
6. Turn the sander **ON** and check the belt tracking. If the belt does not stay in the center of the idler and drive rollers, adjust the tracking with the tracking control knob (refer to **Tracking Belt** on **Page 41** for further detail).



Tracking Belt

The aim of tracking the belt is to keep it centered on the rollers.

To track the belt:

1. Pre-track the belt according to **Pre-Tracking Belt** on **Page 28**.
2. Tie back loose clothing and long hair to protect yourself from getting caught in the moving sanding belt when you start the machine.
3. Loosen the lock nut on the belt tracking knob.
4. Turn the sander **ON**, and using the tracking control knob (see **Figure 77**), carefully adjust the tracking in or out until the sanding belt is centered on the main roller (see **Figure 47, Page 28**).

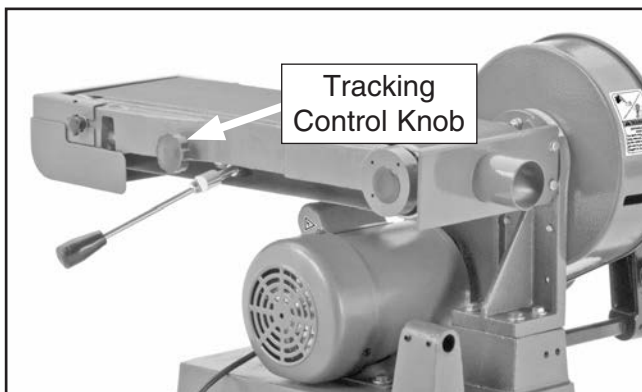

Figure 77. Tracking control knob.

Note: *The tracking control knob is very sensitive; adjust it carefully in small increments. Turning the knob clockwise moves the belt toward the front of the sander.*

5. Tighten the belt tracking knob lock nut.

Changing Sanding Disc

The model G1014Z/G1014ZX accepts 9" diameter paper-backed pressure sensitive adhesive (PSA) discs (refer to **Accessories** on **Page 42**).

To change the sanding disc:

1. **DISCONNECT MACHINE FROM POWER!**
2. Remove the work table and miter gauge.
3. Unscrew the pulley cover thumb knob, open the cover, then remove the existing PSA disc.
4. Remove dried-on adhesive from the cast iron disc with acetone or lacquer thinner and a brush, then let it dry.
5. Peel off the backing from the new PSA disc, then press it onto the cast iron plate, making sure it contacts the surface evenly.
6. Close the pulley cover, install the lock knob, then install the work table and miter gauge.

CAUTION: *Follow the manufacturer's safety recommendations when using acetone or lacquer thinner.*



SECTION 5: ACCESSORIES

!WARNING

Installing unapproved accessories may cause machine to malfunction, resulting in serious personal injury or machine damage. To reduce this risk, only install accessories recommended for this machine by Grizzly.

NOTICE

Refer to our website or latest catalog for additional recommended accessories.

PRO-STIK® Abrasive Surface Cleaners

Extend the life of your abrasive belts! Choose the PRO-STIK® with a handle for greater control or without a handle for more usable area.

<u>Model</u>	<u>Size</u>
W1306	1½" x 1½" x 8½"
W1307	2" x 2" x 12"
W1308	1½" x 1½" x 9" with Handle
W1309	2" x 2" x 11" with Handle

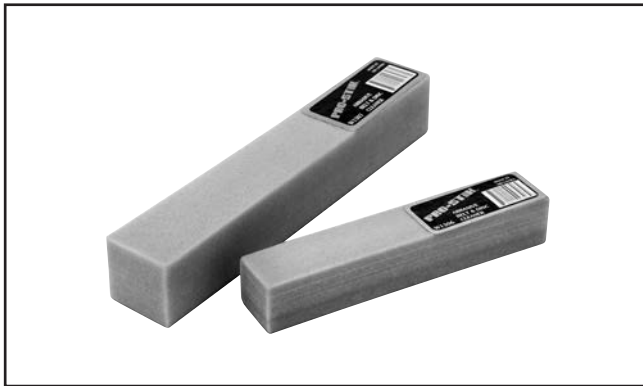

Figure 78. PRO-STIK® abrasive cleaners.

9" PSA Aluminum Oxide Sanding Discs

Our aluminum oxide sanding discs are manufactured in ISO 9002 factories to ensure the highest quality and are available in packs of two.

Grit	Model
60 Grit.....	D1321
80 Grit.....	D1322
100 Grit.....	D1323
120 Grit.....	D1324
150 Grit.....	D1325
180 Grit.....	D1326
220 Grit.....	D1327



Figure 79. 9" Sandpaper discs.

6" x 48" Aluminum Oxide Sanding Belts

Our aluminum oxide sanding belts are sized right for all of your belt sanding needs and are sold in packs of 10.

Grit	Model
60 Grit.....	H3515
80 Grit.....	H3516
100 Grit.....	H3517
120 Grit.....	H3518
150 Grit.....	H3519
180 Grit.....	H3520
220 Grit.....	H3521

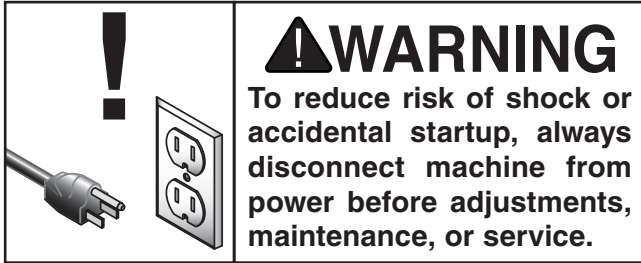

Figure 80. Assortment of sanding belts.

order online at www.grizzly.com or call 1-800-523-4777



SECTION 6: MAINTENANCE



Schedule

For optimum performance from this machine, this maintenance schedule must be strictly followed.

Ongoing

To minimize your risk of injury and maintain proper machine operation, shut down the machine immediately if you ever observe any of the items below, and fix the problem before continuing operations:

- Loose mounting bolts.
- Damaged sanding belt or disc.
- Worn or damaged wires.
- Any other unsafe condition.

After Each Use

- Clean any shavings and dust from between platen and belt.
- Sweep surrounding dust and shavings.
- Clean/protect table.

Weekly Maintenance

- Sweep or vacuum dust and shavings from inside belt compartment and inside machine base.

Monthly Check

- Check and lubricate table support rod.
- V-belt tension, damage, or wear.
- Sanding belt tension.

Annually

- Check and lubricate rocker plate.

Cleaning & Protecting

Cleaning the Model G1014Z G1014ZX is relatively easy. Vacuum excess wood chips and sawdust, and wipe off the remaining dust with a dry cloth. If any resin has built up, use a resin dissolving cleaner to remove it.

Protect the unpainted cast iron table by wiping it clean after every use—this ensures moisture from wood dust does not remain on bare metal surfaces. Keep the table rust-free with regular applications of products like G96® Gun Treatment, SLIPIT®, or Boeshield® T-9.

G5562—SLIPIT® 1 Qt. Gel

G5563—SLIPIT® 12 Oz. Spray

G2870—Boeshield® T-9 4 Oz. Spray

G2871—Boeshield® T-9 12 Oz. Spray

H3788—G96® Gun Treatment 12 Oz. Spray



Figure 81. Recommended products for protecting unpainted cast iron/steel parts on machinery.



Cleaning Sanding Belt/Disc

Using an abrasive belt/disc cleaner can prolong the life of a clogged sanding belt/disc, provided it is in otherwise good condition. See **Accessories** on **Page 42** for more details.

To clean the sanding belt/disc:

1. Turn the machine **ON**.
2. Using the back stop or work table as support, rub the abrasive cleaner on the sanding belt/disc in a continuous motion, covering the entire surface of the belt/disc until the belt/disc is no longer clogged.
3. Turn the machine **OFF**.

Lubrication

It is essential to clean the components before lubricating them, because dust and chips build up on lubricated components and make the components hard to move. Simply adding more grease to the components with built-up grime on them will not yield smooth moving components.

Table Support Rod

Oil Type T23962 or ISO 68 Equivalent
 Oil Amount..... Thin Coat
 Lubrication Frequency Monthly

Use a shop rag and mineral spirits to wipe away any built up grime and debris off of the table support rod, then brush on a thin coat of light machine oil onto the shaft (see **Figure 82**). Move the work table back and forth to distribute the oil.

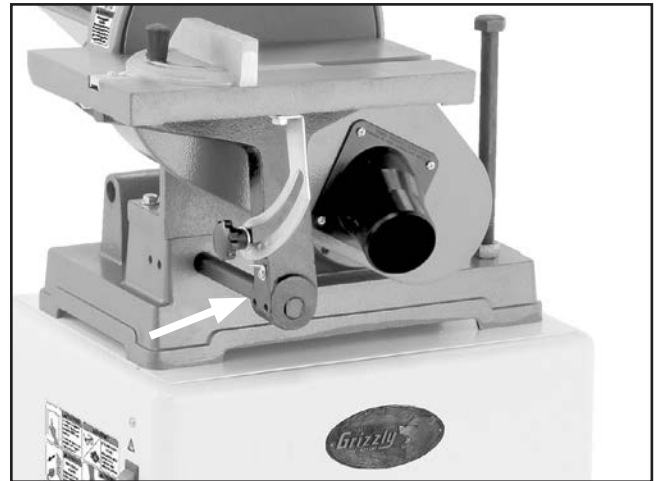

Figure 82. Table support rod lubrication.

Rocker Plate

Oil Type NLGI#2 Grease
 Oil Amount..... Dollop
 Lubrication Frequency Annually

Clean the rocker plate with mineral spirits and a rag, and brush a dollop of grease onto the rocker plate. Move the quick release tension lever forward and backward to spread the grease (see **Figure 83**).

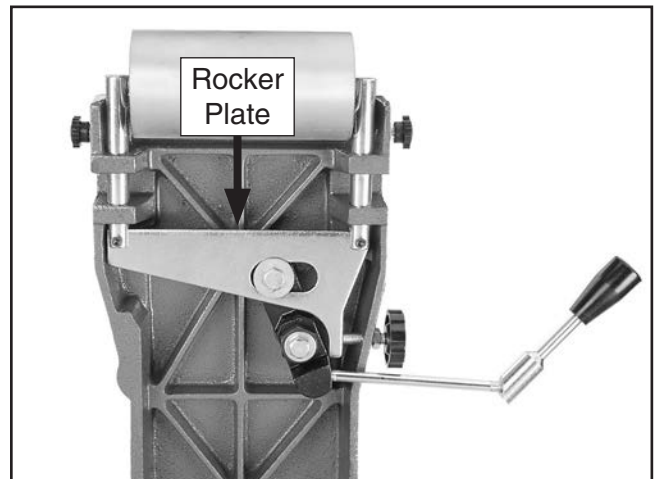

Figure 83. Rocker plate lubrication.



SECTION 7: SERVICE

Review the troubleshooting procedures in this section if a problem develops with your machine. If you need replacement parts or additional help with a procedure, call our Technical Support. **Note:** *Please gather the serial number and manufacture date of your machine before calling.*

Troubleshooting

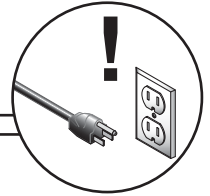

Motor & Electrical

Symptom	Possible Cause	Possible Solution
Machine does not start, or power supply breaker immediately trips after startup.	<ol style="list-style-type: none"> 1. Switch disabling key removed. 2. Motor cord not connected to power cord (G1014ZX only). 3. Incorrect power supply voltage or circuit size. 4. Plug/receptacle at fault/wired wrong. 5. Power supply circuit breaker tripped or fuse blown. 6. Motor wires connected incorrectly. 7. Start capacitor at fault. 8. Centrifugal switch adjustment/contact points at fault. 9. Wiring broken, disconnected, or corroded. 10. ON/OFF switch at fault. 11. Motor or motor bearings at fault. 	<ol style="list-style-type: none"> 1. Install switch disabling key. 2. Connect motor cord to power cord (G1014ZX). 3. Ensure correct power supply voltage and circuit size (Page 12). 4. Test for good contacts; correct the wiring (Page 51). 5. Ensure circuit is free of shorts. Reset circuit breaker or replace fuse. 6. Correct motor wire connections (Page 51). 7. Test/replace if at fault. 8. Adjust centrifugal switch/clean contact points. Replace either if at fault. 9. Fix broken wires or disconnected/corroded connections (Page 51). 10. Replace switch. 11. Replace motor.
Machine stalls or is underpowered.	<ol style="list-style-type: none"> 1. Workpiece material unsuitable for machine. 2. V-belt slipping/pulleys misaligned. 3. Motor wires connected incorrectly. 4. Plug/receptacle at fault/wired wrong. 5. Pulley slipping on shaft. 6. Machine undersized for task. 7. Motor overheated. 8. Extension cord too long. 9. Centrifugal switch/contact points at fault. 10. Motor or motor bearings at fault. 	<ol style="list-style-type: none"> 1. Only sand wood/ensure moisture is below 20% (Page 33). 2. Clean/replace V-belt (Page 50); ensure pulleys are aligned (Page 50). 3. Correct motor wire connections (Page 51). 4. Test for good contacts; correct the wiring (Page 51). 5. Tighten/replace loose pulley/shaft. 6. Clean (Page 44)/replace sanding belt (Page 39)/disc (Page 41); reduce feed rate/sanding depth. 7. Clean motor, let cool, and reduce workload. 8. Move machine closer to power supply; use shorter extension cord. 9. Adjust centrifugal switch/clean contact points. Replace either if at fault. 10. Replace motor.
Machine has vibration or noisy operation.	<ol style="list-style-type: none"> 1. Motor or component loose. 2. Stand feet not adjusted/attached properly. 3. V-belt worn, loose, pulleys misaligned, or belt slapping cover. 4. Pulley loose. 5. Motor mount loose/broken. 	<ol style="list-style-type: none"> 1. Replace damaged or missing bolts/nuts or tighten if loose. 2. Adjust/re-install stand feet to stabilize machine. 3. Inspect/replace V-belt (Page 50). Realign pulleys if necessary (Page 50). 4. Secure pulley on shaft. 5. Tighten/replace.



Motor & Electrical (Cont.)

Symptom	Possible Cause	Possible Solution
Machine has vibration or noisy operation.	<ol style="list-style-type: none"> 6. Sanding disc out of balance or loose. 7. Motor fan rubbing on fan cover. 8. Centrifugal switch needs adjustment/at fault. 9. Motor bearings at fault. 10. Work table support rod rubbing on motor. 	<ol style="list-style-type: none"> 6. Tighten disc hub or replace disc. 7. Fix/replace fan cover; replace loose/damaged fan. 8. Adjust/replace if at fault. 9. Test by rotating shaft; rotational grinding/loose shaft requires bearing replacement. 10. Adjust table support rod.

Operation

Symptom	Possible Cause	Possible Solution
Sanding belt slaps or vibrates excessively.	<ol style="list-style-type: none"> 1. Sanding belt not tensioned properly. 2. Sanding belt tracking needs adjustment. 3. Sanding belt is stretched unevenly, worn, or damaged. 4. Sanding belt roller is loose. 	<ol style="list-style-type: none"> 1. Tension sanding belt (Page 40). 2. Adjust sanding belt tracking (Page 41). 3. Replace sanding belt (Page 39). 4. Tighten sanding belt roller.
Sanding belt will not track properly.	<ol style="list-style-type: none"> 1. Sanding belt is not tensioned properly. 2. Sanding belt is stretched unevenly, worn, or damaged. 3. Sanding belt roller is worn. 	<ol style="list-style-type: none"> 1. Tension sanding belt (Page 40). 2. Replace sanding belt (Page 39). 3. Replace sanding belt roller.
Sanding belt slips during use.	<ol style="list-style-type: none"> 1. Sanding belt is not tensioned properly. 2. Excessive workpiece pressure. 3. V-belt is worn or not tensioned properly. 	<ol style="list-style-type: none"> 1. Tension sanding belt (Page 40). 2. Reduce workpiece pressure. 3. Inspect/tension V-belt (Page 49).
Belts/discs clog quickly or excessive sanding belt/disc replacement.	<ol style="list-style-type: none"> 1. Sanding wet stock. 2. Not using full width of sanding surface. 3. Excessive workpiece pressure. 4. Using too fine of sanding grit. 5. Sanding softwood. 	<ol style="list-style-type: none"> 1. Only sand wood/ensure moisture is below 20% (Page 33). 2. Move workpiece back and forth across sanding surface. 3. Reduce workpiece pressure. 4. Use coarser grit sandpaper (Page 32). 5. Use different stock or accept characteristics and plan on frequently cleaning (Page 44)/replacing sanding belt (Page 39)/disc (Page 41).
Deep sanding grooves or scars in workpiece.	<ol style="list-style-type: none"> 1. Not using full width of sanding surface. 2. Workpiece sanded across grain. 3. Excessive workpiece pressure. 4. Sandpaper too coarse for desired finish. 	<ol style="list-style-type: none"> 1. Move workpiece back and forth across sanding surface. 2. Sand workpiece with grain. 3. Reduce workpiece pressure. 4. Use finer grit sandpaper (Page 32).
Burn marks on workpiece.	<ol style="list-style-type: none"> 1. Not using full width of sanding surface. 2. Excessive workpiece pressure. 3. Using too fine of sanding grit. 4. Sanding belt/disc clogged/worn. 	<ol style="list-style-type: none"> 1. Move workpiece back and forth across sanding surface. 2. Reduce workpiece pressure. 3. Use coarser grit sandpaper (Page 32). 4. Clean (Page 44)/replace sanding belt (Page 39)/disc (Page 41).
Snake-shaped marks on workpiece.	<ol style="list-style-type: none"> 1. Sanding belt/disc dirty/damaged. 	<ol style="list-style-type: none"> 1. Clean (Page 44)/replace sanding belt (Page 39)/disc (Page 41).
Glazed sanding surfaces.	<ol style="list-style-type: none"> 1. Sanding wet stock. 	<ol style="list-style-type: none"> 1. Only sand wood/ensure moisture is below 20% (Page 33).



Operation (Cont.)

Symptom	Possible Cause	Possible Solution
Glazed sanding surfaces.	<ol style="list-style-type: none"> 2. Sanding stock with high pitch/residue. 3. Sanding belt/disc worn or filled with pitch/residue. 	<ol style="list-style-type: none"> 2. Use different stock or accept characteristics and plan on frequently cleaning (Page 44)/replacing sanding belt (Page 39)/disc (Page 41). 3. Replace sanding belt (Page 39)/disc (Page 41).
Poor, non-aggressive sanding results.	<ol style="list-style-type: none"> 1. Using too fine of sanding grit. 2. Sanding belt/disc clogged/worn. 	<ol style="list-style-type: none"> 1. Use coarser grit sandpaper (Page 32). 2. Clean (Page 44)/replace sanding belt (Page 39)/disc (Page 41).
Abrasive grit rubs off easily.	<ol style="list-style-type: none"> 1. Sanding belt/disc has been stored in an incorrect environment. 2. Sanding belt/disc has been folded or crushed. 	<ol style="list-style-type: none"> 1. Replace sanding belt (Page 39)/disc (Page 41). Store belt/disc in a cool, dry area. 2. Replace sanding belt (Page 39)/disc (Page 41). Do not bend or fold belt/disc.
Workpiece not sanded square when table is set to 90°.	<ol style="list-style-type: none"> 1. Table is not square to sanding belt/disc. 	<ol style="list-style-type: none"> 1. Calibrate table tilt (this page).
Workpiece not sanded square when miter gauge is set to 90°.	<ol style="list-style-type: none"> 1. Miter gauge body is not square to miter bar. 	<ol style="list-style-type: none"> 1. Calibrate miter gauge scale (Page 48).
Workpiece frequently gets pulled out of your hand.	<ol style="list-style-type: none"> 1. Not supporting the workpiece against the stop. 2. Starting the workpiece on a leading corner. 	<ol style="list-style-type: none"> 1. Use back stop or miter gauge to support workpiece. 2. Start workpiece on a trailing corner.

Squaring Work Table to Sanding Belt/Disc

Tools Needed	Qty
Machinist's Square	1

To square the work table to the sanding belt/disc:

1. DISCONNECT MACHINE FROM POWER!
2. Place a machinist's square or other 90° measuring tool against the work table and sanding belt/disc (see **Figure 84**).

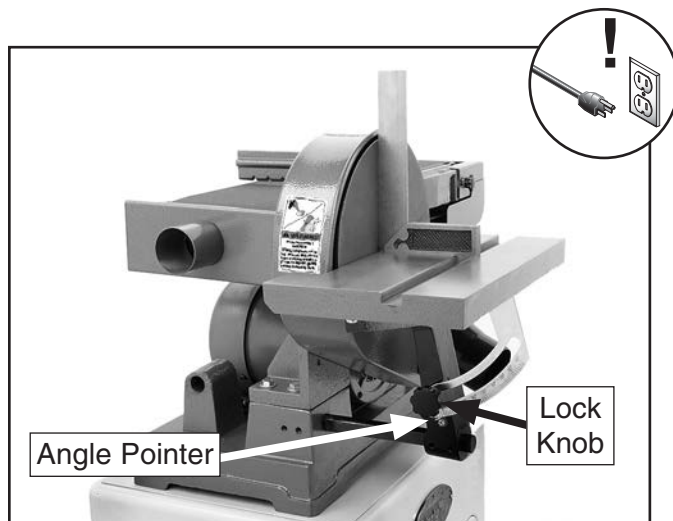

Figure 84. Using a machinist's square to adjust the work table to 90°.

3. Loosen the table lock knob, adjust the table square with the sanding belt/disc, then re-tighten the table lock knob.
4. Loosen the Phillips head screw on the angle pointer, position the red scale pointer over the "0" mark on the angle scale, then re-tighten the screw.



Adjusting Miter Slot-Belt/Disc Parallelism

If the miter slot is not parallel with the sanding belt or disc, workpieces may not be sanded correctly when using the miter gauge.

Tools Needed	Qty
Combination Square.....	1

To adjust the miter slot parallel with the sanding belt/disc:

1. DISCONNECT MACHINE FROM POWER!
2. Remove the miter gauge, then place a combination square with the 90° square in the miter slot, as shown in **Figure 85**.

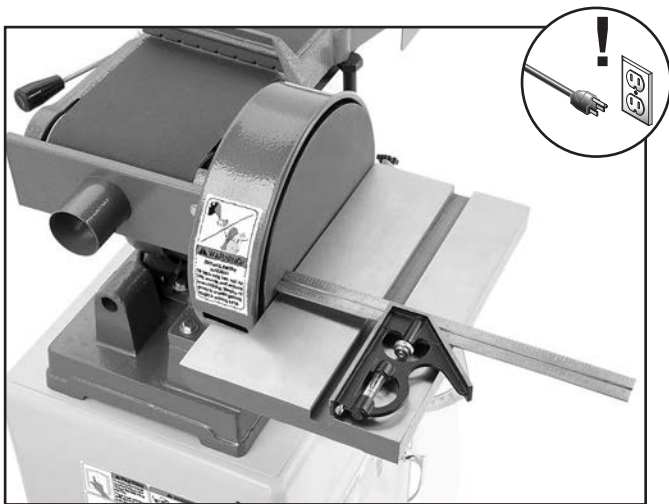

Figure 85. Checking miter slot parallelism (sanding disc shown).

3. Slide the square to the other side and check to see if the distance from the slot to the sanding belt/disc is the same.

— If the distance *is* the same, no adjustments need to be made.

— If the distance *is not* the same from side to side, loosen the screws (see **Figure 66** on **Page 37**) that secure the work table arm to the work table and adjust the table so it is approximately 1/16" away from the sanding belt/disc across its entire length.

4. Repeat **Step 3** and adjust the table as needed until the miter slot is parallel with the sanding belt/disc on both sides.

Calibrating Miter Gauge

Calibrate the miter gauge if the angle of sanded workpieces does not match what the miter gauge scale indicates.

To calibrate the miter gauge:

1. Place one edge of a machinist's square against the face of the miter gauge and the other against the sanding disc (see **Figure 86**) or sanding belt.

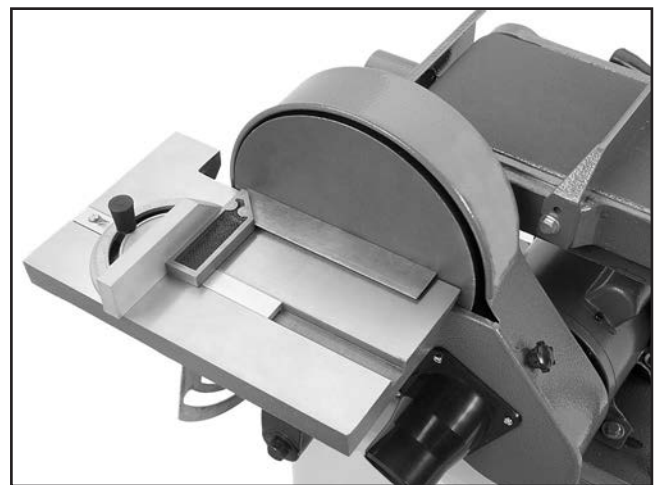

Figure 86. Calibrating miter gauge with square.

2. Loosen the lock knob on the miter gauge and adjust it flush with the edge of the square.
3. Tighten the lock knob and verify the setting.

Note: Sometimes the tightening procedure can affect the adjustment.

4. Loosen the screw that secures the angle pointer and adjust the pointer to the 0° mark on the scale.
5. Retighten the screw that secures the angle pointer.



V-Belt Tension & Replacement

The V-belt is pre-installed and tensioned at the factory. However, we recommend you verify this setting and also check the V-belt tension after the first 16 hours of operation, during which the belt will stretch and seat.

Tools Needed	Qty
Hex Wrench 4mm.....	1
Wrench 12mm	1

Tensioning V-Belt

1. DISCONNECT MACHINE FROM POWER!
2. Remove the work table assembly from the sanding disc, then open the pulley cover.
3. While looking through the access hole on the side of the pulley cover (see **Figure 31** on **Page 24**), rotate the cast iron plate and loosen each of the set screws that secure the plate to the drive shaft.
4. Remove the cast iron plate to expose the V-belt.
5. Push the center of the V-belt with your finger to check belt tension. The belt is correctly tensioned when there is approximately $\frac{1}{4}$ " deflection when it is pushed with moderate pressure, as shown in **Figure 87**.

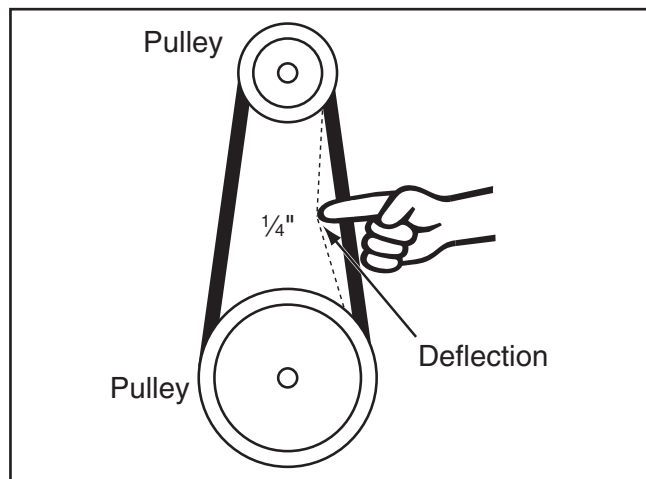

Figure 87. Checking belt tension.

- If there is approximately $\frac{1}{4}$ " deflection, no adjustments are necessary. Go to **Step 9**.
- If there is more or less than that $\frac{1}{4}$ " deflection when you push the V-belt with moderate pressure, follow **Steps 6–7**.

6. Loosen the (4) hex bolts that secure the motor to the base, as shown in **Figures 88–89**, then slide the motor toward the back of the sander to reduce belt tension or slide it toward the front of the sander to increase tension.

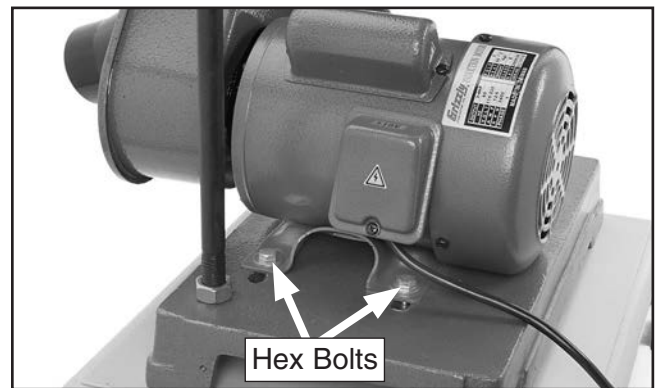

Figure 88. Rear motor mounting bolts.

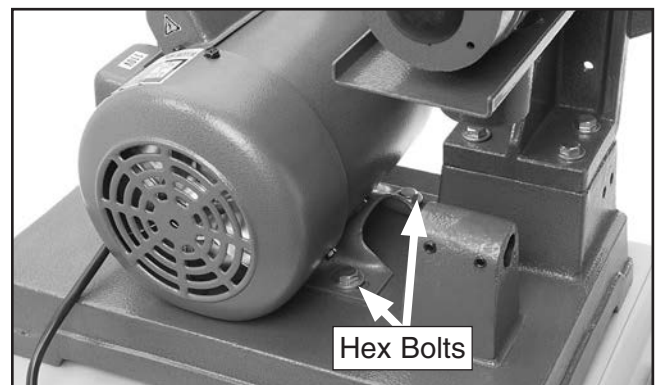

Figure 89. Front motor mounting bolts.

7. Tighten the (4) hex bolts to secure the motor.
8. Repeat **Step 5** and re-adjust the V-belt tension if necessary.
9. Re-install the cast iron plate onto the drive shaft and secure with the set screws, close and secure the pulley cover, then re-install the work table.



Replacing V-Belt

1. DISCONNECT MACHINE FROM POWER!
2. Follow **Steps 2–4** in **Tensioning V-Belt** on **Page 49**.
3. Loosen the (4) hex bolts that secure the motor to the base, as shown in **Figures 88–89** on **Page 49**, then slide the motor toward the back of the sander to reduce belt tension.
4. Remove the V-belt and replace it with a new one.
5. Slide the motor toward the front of the sander, then tighten the (4) hex bolts on the motor base.
6. Repeat **Step 5** on **Page 49** and adjust the V-belt tension as needed.
7. Re-install the cast iron plate onto the drive shaft and secure it with the two set screws, close and secure the pulley cover, then re-install the work table.

3. Open the pulley cover.
4. Loosen the set screws that secure the cast iron plate to the drive shaft, then remove the plate.
5. Place a 12" straightedge across both pulleys, as shown in **Figure 90**.

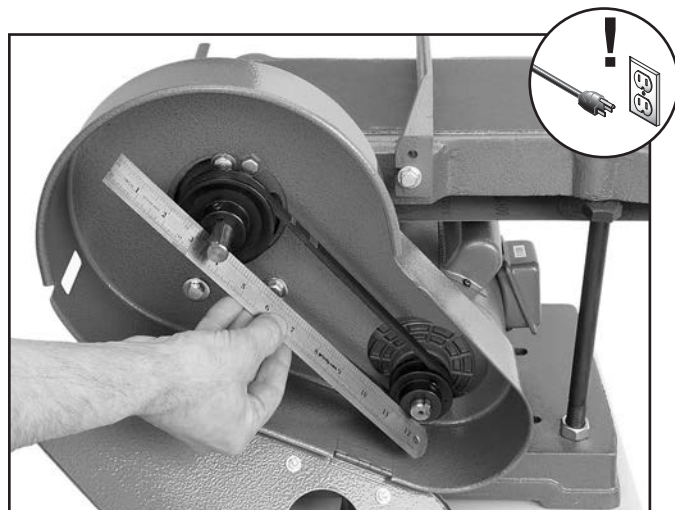

Figure 90. Checking pulley alignment.

—If the straightedge touches the pulleys evenly, no adjustments need to be made. Go to **Step 7**.

—If there is a gap between the straightedge and one of the pulleys, that pulley needs to be adjusted. Proceed to **Step 6**.

6. Loosen the set screw on the pulley where you noticed the gap, then adjust the pulley so it touches the bottom of the straightedge when it is extended across both pulleys, as shown in **Figure 90**.
7. Tighten the pulley set screw, re-install the cast iron plate, close the pulley cover, then re-install the thumb knob and work table.

Pulley Alignment

Proper pulley alignment prevents premature belt wear. The pulleys are properly aligned when they are parallel and in the same plane as each other.

Tools Needed	Qty
Hex Wrench 4mm.....	1
Straightedge 12".....	1
Standard Screwdriver.....	1

To check and adjust pulley alignment:

1. DISCONNECT MACHINE FROM POWER!
2. Remove the work table assembly and miter gauge.



SECTION 8: WIRING

These pages are current at the time of printing. However, in the spirit of improvement, we may make changes to the electrical systems of future machines. Compare the manufacture date of your machine to the one stated in this manual, and study this section carefully.

If there are differences between your machine and what is shown in this section, call Technical Support at (570) 546-9663 for assistance BEFORE making any changes to the wiring on your machine. An updated wiring diagram may be available. **Note:** *Please gather the serial number and manufacture date of your machine before calling. This information can be found on the main machine label.*

WARNING

Wiring Safety Instructions

SHOCK HAZARD. Working on wiring that is connected to a power source is extremely dangerous. Touching electrified parts will result in personal injury including but not limited to severe burns, electrocution, or death. Disconnect the power from the machine before servicing electrical components!

MODIFICATIONS. Modifying the wiring beyond what is shown in the diagram may lead to unpredictable results, including serious injury or fire. This includes the installation of unapproved after-market parts.

WIRE CONNECTIONS. All connections must be tight to prevent wires from loosening during machine operation. Double-check all wires disconnected or connected during any wiring task to ensure tight connections.

CIRCUIT REQUIREMENTS. You MUST follow the requirements at the beginning of this manual when connecting your machine to a power source.

WIRE/COMPONENT DAMAGE. Damaged wires or components increase the risk of serious personal injury, fire, or machine damage. If you notice that any wires or components are damaged while performing a wiring task, replace those wires or components.

MOTOR WIRING. The motor wiring shown in these diagrams is current at the time of printing but may not match your machine. If you find this to be the case, use the wiring diagram inside the motor junction box.















CAPACITORS/INVERTERS. Some capacitors and power inverters store an electrical charge for up to 10 minutes after being disconnected from the power source. To reduce the risk of being shocked, wait at least this long before working on capacitors.

EXPERIENCING DIFFICULTIES. If you are experiencing difficulties understanding the information included in this section, contact our Technical Support at (570) 546-9663.

NOTICE

The photos and diagrams included in this section are best viewed in color. You can view these pages in color at www.grizzly.com.

COLOR KEY

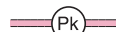
BLACK 	BLUE 	YELLOW 	LIGHT BLUE 
WHITE 	BROWN 	YELLOW GREEN 	BLUE WHITE 
GREEN 	GRAY 	PURPLE 	TURQUOISE 
RED 	ORANGE 	PINK 	



G1014Z Wiring Diagram

MOTOR (Prewired 110V)

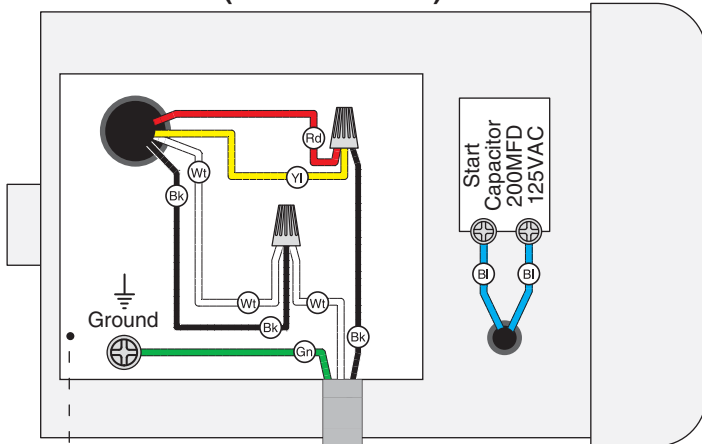
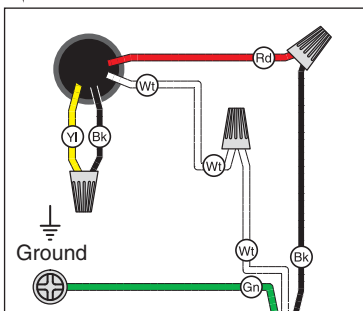
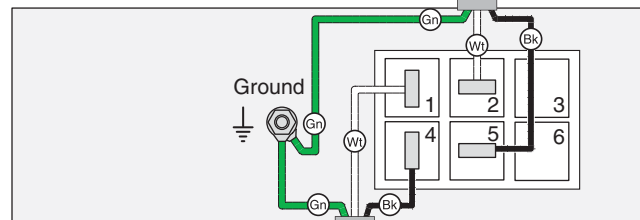

Figure 91. G1014Z 110V motor wiring.

MOTOR (Wired 220V)



(Wired 220V)



PADDLE SWITCH
KEDU HY18
(viewed from behind)

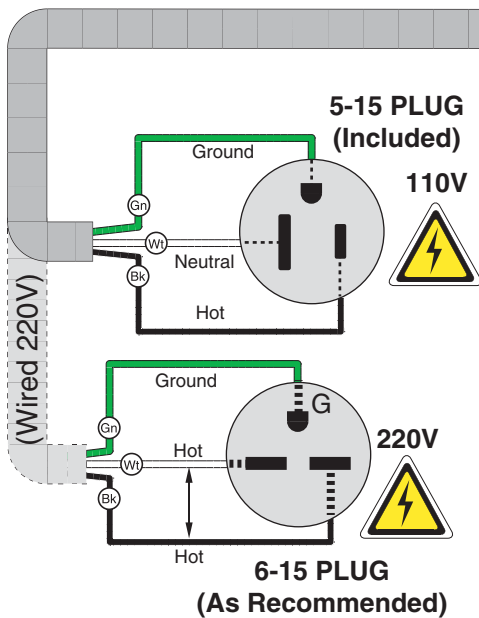

Figure 92. G1014Z switch wiring.



SECTION 9: PARTS

We do our best to stock replacement parts when possible, but we cannot guarantee that all parts shown are available for purchase. Call (800) 523-4777 or visit www.grizzly.com/parts to check for availability.

G1014Z Main

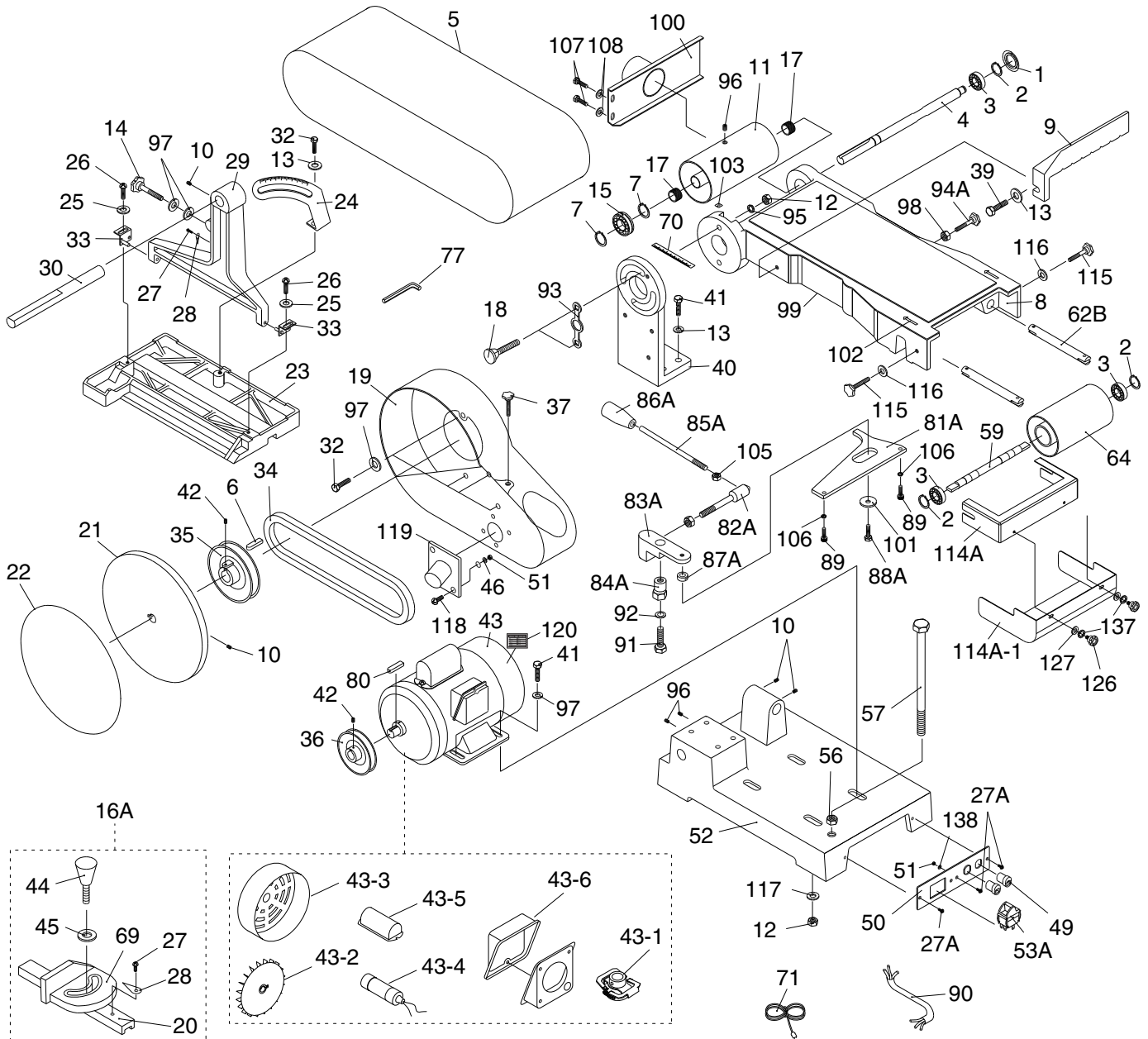

G1014Z Main Parts List

REF	PART #	DESCRIPTION
1	P1014Z001	DUST COVER
2	P1014Z002	EXT RETAINING RING 12MM
3	P1014Z003	BALL BEARING 6201-2RS
4	P1014Z004	DRIVER ROLLER SHAFT
5	P1014Z005	SANDING BELT 6" X 48" A60 (2-PC)
6	P1014Z006	KEY 5 X 5 X 55
7	P1014Z007	EXT RETAINING RING 15MM
8	P1014Z008	SANDING BELT FRAME
9	P1014Z009	BACK STOP
10	P1014Z010	SET SCREW 5/16-18 X 3/8
11	P1014Z011	DRIVE ROLLER
12	P1014Z012	HEX NUT 5/16-18
13	P1014Z013	FLAT WASHER 5/16
14	P1014Z014	KNOB 5/16-18
15	P1014Z015	BALL BEARING 6202-2RS W/SNAP RING
16A	P1014Z016A	COMPLETE MITER GAUGE ASSY
17	P1014Z017	BUSHING 15 X 19.4 X 12MM
18	P1014Z018	CARRIAGE BOLT 5/16-18 X 1-1/2
19	P1014Z019	PULLEY COVER W/DUST PORT V2.07.00
20	P1014Z020	MITER BAR
21	P1014Z021	CAST IRON DISC V2.02.97
22	P1014Z022	SANDING DISC 9" A60 PSA (2-PC)
23	P1014Z023	TABLE
24	P1014Z024	TRUNNION
25	P1014Z025	FLAT WASHER 1/4
26	P1014Z026	PHLP HD SCR 1/4-20 X 1/2
27	P1014Z027	PHLP HD SCR 10-24 X 3/8
27A	P1014Z027A	FLANGE SCREW 10-24 X 3/8
28	P1014Z028	MITER GAUGE POINTER
29	P1014Z029	TABLE SUPPORT BRACKET V2.01.98
30	P1014Z030	SUPPORT BAR
32	P1014Z032	HEX BOLT 5/16-18 X 1/2
33	P1014Z033	TABLE MOUNT L & R (2 PC SET)
34	P1014Z034	V-BELT M24 3L240
35	P1014Z035	PULLEY
36	P1014Z036	MOTOR PULLEY
37	P1014Z037	KNOB 10-24
39	P1014Z039	HEX BOLT 5/16-18 X 1
40	P1014Z040	BRACKET
41	P1014Z041	HEX BOLT 5/16-18 X 1
42	P1014Z042	SET SCREW 5/16-18 X 3/8
43	P1014Z043	MOTOR 3/4HP 110V/220V 1-PH
43-1	P1014Z043-1	CENTRIFUGAL SWITCH
43-2	P1014Z043-2	MOTOR FAN
43-3	P1014Z043-3	MOTOR FAN COVER
43-4	P1014Z043-4	S CAPACITOR 200M 125V 1-3/8 X 2-1/4
43-5	P1014Z043-5	S CAPACITOR COVER
43-6	P1014Z043-6	JUNCTION BOX COVER
44	P1014Z044	KNOB BOLT 1/4-20 X 3/4
45	P1014Z045	PLASTIC WASHER 1/4-16
46	P1014Z046	FLAT WASHER #10
49	P1014Z049	STRAIN RELIEF M14 TYPE-1 SNAP-IN
50	P1014Z050	SWITCH PLATE

REF	PART #	DESCRIPTION
51	P1014Z051	HEX NUT 10-24
52	P1014Z052	BASE
53A	P1014Z053A	SAFETY PADDLE SWITCH
56	P1014Z056	HEX NUT 5/8-11
57	P1014Z057	HEX BOLT 5/8-11 X 9
59	P1014Z059	IDLER SHAFT V3.08.97
62B	P1014Z062B	ROLLER ADJUST BAR
64	P1014Z064	IDLER ROLLER V3.08.97
69	P1014Z069	MITER BODY
70	P1014Z070	TILT SCALE
71	P1014Z071	POWER CORD 16G 3W 73" 5-15P
77	P1014Z077	HEX WRENCH 4MM
80	P1014Z080	KEY 5 X 5 X 40
81A	P1014Z081A	ROCKER PLATE
82A	P1014Z082A	SHORT LEVER
83A	P1014Z083A	ROCKER ARM
84A	P1014Z084A	ECCENTRIC
85A	P1014Z085A	LONG LEVER
86A	P1014Z086A	KNOB 3/8-16
87A	P1014Z087A	SPACER
88A	P1014Z088A	HEX BOLT 3/8-16 X 3/4
89	P1014Z089	CAP SCREW 10-24 X 5/8
90	P1014Z090	MOTOR CORD 16G 3W 12"
91	P1014Z091	HEX BOLT 3/8-16 X 1-1/2
92	P1014Z092	FLAT WASHER 3/8
93	P1014Z093	WASHER PLATE 19 X 88
94A	P1014Z094A	KNOB 3/8-24
95	P1014Z095	LOCK WASHER 5/16
96	P1014Z096	SET SCREW 5/16-18 X 3/4
97	P1014Z097	FENDER WASHER 5/16 X 21 X 2
98	P1014Z098	HEX NUT 3/8-16
99	P1014Z099	GRAPHITE PAD 6"W X 17"L
100	P1014Z100	DUST PORT
101	P1014Z101	FENDER WASHER 3/8
102	P1014Z102	BELT DIRECTION ARROW
103	P1014Z103	TABLE TILT POINTER
105	P1014Z105	HEX NUT 3/8-16
106	P1014Z106	LOCK WASHER 5MM
107	P1014Z107	HEX BOLT 1/4-20 X 1/2
108	P1014Z108	FLAT WASHER 1/4
114A	P1014Z114A	IDLER ROLLER GUARD V2.03.08
114A-1	P1014Z114A-1	SLEEVE GUARD
115	P1014Z115	LOCK KNOB 1/4-20
116	P1014Z116	FLAT WASHER 1/4
117	P1014Z117	FLAT WASHER 5/16
118	P1014Z118	PHLP HD SCR 10-24 X 3/8
119	P1014Z119	DUST PORT (ABS) 2-1/2"
120	P1014Z120	MOTOR LABEL
126	P1014Z126	LOCK KNOB 10-32
127	P1014Z127	FLAT WASHER #10
137	P1014Z137	LOCK WASHER #10
138	P1014Z138	EXT TOOTH WASHER #10



G1014Z Stand

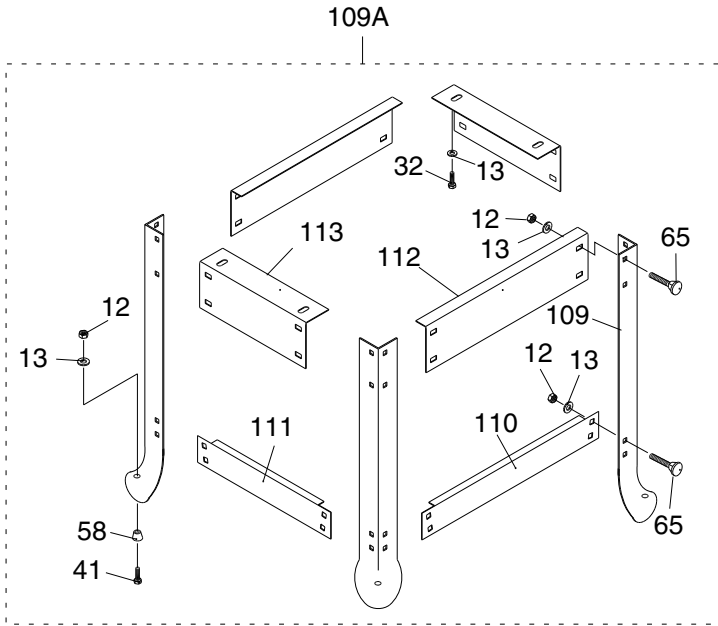

REF	PART #	DESCRIPTION
12	P1014Z012	HEX NUT 5/16-18
13	P1014Z013	FLAT WASHER 5/16
32	P1014Z032	HEX BOLT 5/16-18 X 1/2
41	P1014Z041	HEX BOLT 5/16-18 X 1
58	P1014Z058	RUBBER FOOT
65	P1014Z065	CARRIAGE BOLT 5/16-18 X 5/8
109	P1014Z109	LEG
109A	P1014Z109A	STAND ASSEMBLY
110	P1014Z110	LOWER BRACE (LONG)
111	P1014Z111	LOWER BRACE (SHORT)
112	P1014Z112	UPPER BRACE (LONG)
113	P1014Z113	UPPER BRACE (SHORT)

G1014Z Labels & Cosmetics

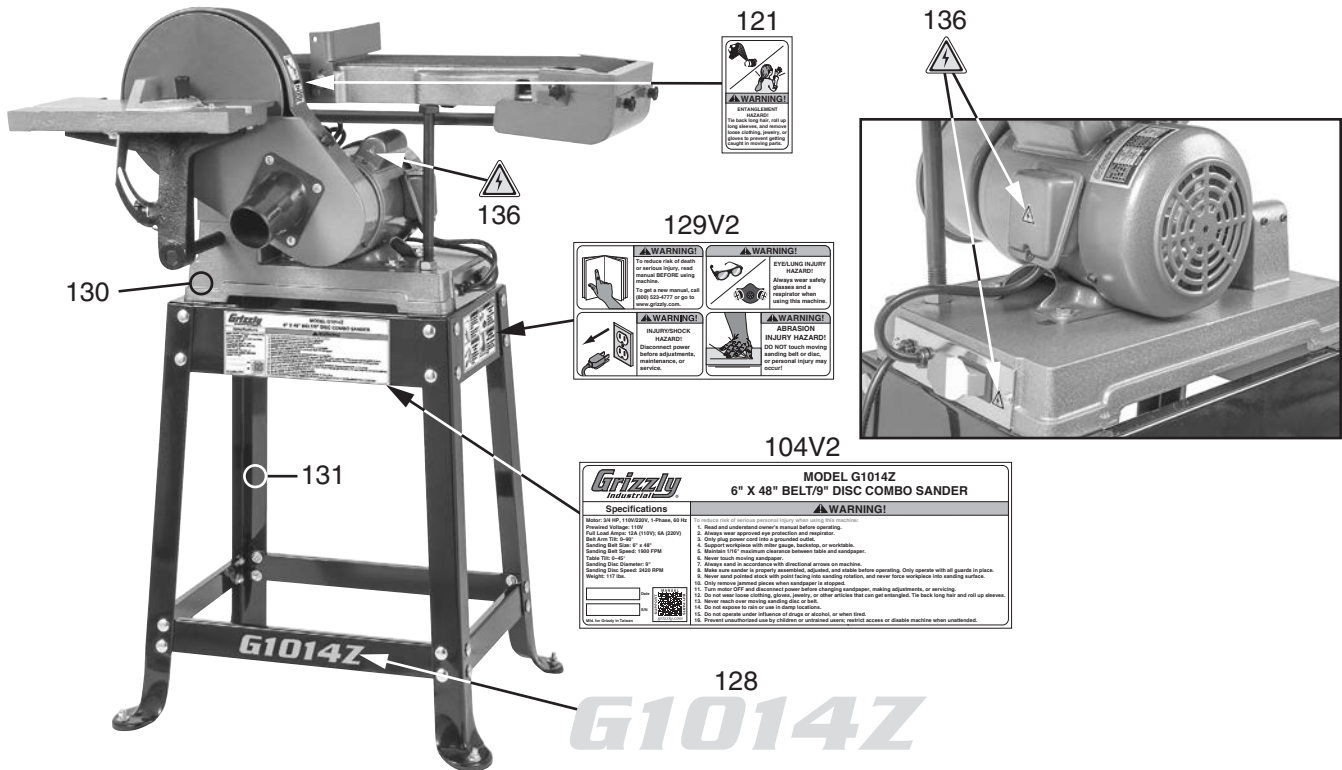

REF	PART #	DESCRIPTION
104V2	P1014Z104V2	MACHINE ID LABEL V2.08.22
121	P1014Z121	ENTANGLEMENT LABEL
128	P1014Z128	MODEL NUMBER LABEL
129V2	P1014Z129V2	COMBO WARNING LABEL V2.08.22

REF	PART #	DESCRIPTION
130	P1014Z130	TOUCH-UP PAINT, GRIZZLY GREEN
131	P1014Z131	TOUCH-UP PAINT, GRIZZLY BLACK
136	P1014Z136	ELECTRICITY LABEL



G1014ZX Main

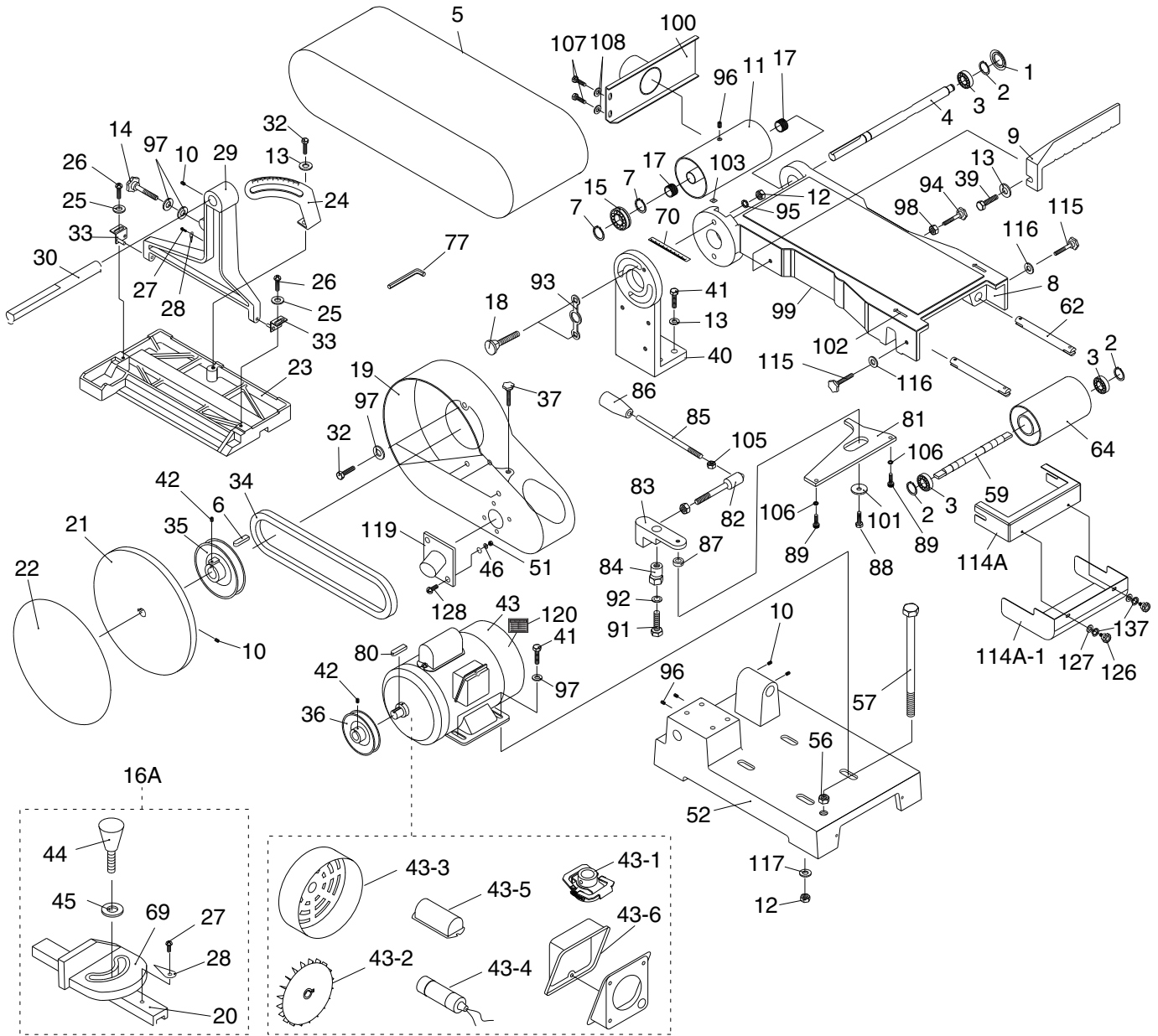

G1014ZX Main Parts List

REF	PART #	DESCRIPTION
1	P1014ZX001	DUST COVER
2	P1014ZX002	EXT RETAINING RING 12MM
3	P1014ZX003	BALL BEARING 6201-2RS
4	P1014ZX004	DRIVER ROLLER SHAFT
5	P1014ZX005	SANDING BELT 6" X 48" A60 (2-PC)
6	P1014ZX006	KEY 5 X 5 X 40
7	P1014ZX007	EXT RETAINING RING 15MM
8	P1014ZX008	SANDING BELT FRAME
9	P1014ZX009	BACK STOP
10	P1014ZX010	SET SCREW 5/16-18 X 3/8
11	P1014ZX011	DRIVE ROLLER
12	P1014ZX012	HEX NUT 5/16-18
13	P1014ZX013	FLAT WASHER 5/16
14	P1014ZX014	KNOB 5/16-18
15	P1014ZX015	BALL BEARING 6202-2RS W/SNAP RING
16A	P1014ZX016A	COMPLETE MITER GAUGE ASSY
17	P1014ZX017	BUSHING 15 X 19.4 X 12MM
18	P1014ZX018	CARRIAGE BOLT 5/16-18 X 1-1/2
19	P1014ZX019	PULLEY COVER W/DUST PORT
20	P1014ZX020	MITER BAR
21	P1014ZX021	CAST IRON DISC
22	P1014ZX022	SANDING DISC 9" A60 PSA (2-PC)
23	P1014ZX023	TABLE
24	P1014ZX024	TRUNNION
25	P1014ZX025	FLAT WASHER 1/4
26	P1014ZX026	PHLP HD SCR 1/4-20 X 1/2
27	P1014ZX027	PHLP HD SCR 10-24 X 3/8
28	P1014ZX028	MITER GAUGE POINTER
29	P1014ZX029	TABLE SUPPT BRACKET
30	P1014ZX030	SUPPORT BAR
32	P1014ZX032	HEX BOLT 5/16-18 X 1/2
33	P1014ZX033	TABLE MOUNT L & R (2 PC SET)
34	P1014ZX034	V-BELT M-24 3L240
35	P1014ZX035	PULLEY
36	P1014ZX036	MOTOR PULLEY
37	P1014ZX037	KNOB 10-24
39	P1014ZX039	HEX BOLT 5/16-18 X 1
40	P1014ZX040	BRACKET
41	P1014ZX041	HEX BOLT 5/16-18 X 1
42	P1014ZX042	SET SCREW 5/16-18 X 3/8
43	P1014ZX043	MOTOR 3/4 HP 110V/220V 1-PH
43-1	P1014ZX043-1	CENTRIFUGAL SWITCH
43-2	P1014ZX043-2	MOTOR FAN
43-3	P1014ZX043-3	MOTOR FAN COVER
43-4	P1014ZX043-4	S CAPACITOR 200M 125V 1-3/8 x 2-1/4
43-5	P1014ZX043-5	S CAPACITOR COVER
43-6	P1014ZX043-6	JUNCTION BOX COVER
44	P1014ZX044	KNOB BOLT 1/4-20 X 3/4
45	P1014ZX045	PLASTIC WASHER 1/4-16

REF	PART #	DESCRIPTION
46	P1014ZX046	FLAT WASHER #10
51	P1014ZX051	HEX NUT 10-24
52	P1014ZX052	BASE
56	P1014ZX056	HEX NUT 5/8-11
57	P1014ZX057	HEX BOLT 5/8-11 X 9
59	P1014ZX059	IDLER SHAFT
62	P1014ZX062	ROLLER ADJ UST BAR
64	P1014ZX064	IDLER ROLLER
69	P1014ZX069	MITER BODY
70	P1014ZX070	TILT SCALE
77	P1014ZX077	HEX WRENCH 4MM
80	P1014ZX080	KEY 5 X 5 X 40
81	P1014ZX081	ROCKER PLATE
82	P1014ZX082	SHORT LEVER
83	P1014ZX083	ROCKER ARM
84	P1014ZX084	ECCENTRIC
85	P1014ZX085	LONG LEVER
86	P1014ZX086	KNOB 3/8-16
87	P1014ZX087	SPACER
88	P1014ZX088	HEX BOLT 3/8-16 X 3/4
89	P1014ZX089	CAP SCREW 10-24 X 5/8
91	P1014ZX091	HEX BOLT 3/8-16 X 1-1/2
92	P1014ZX092	FLAT WASHER 3/8
93	P1014ZX093	WASHER PLATE 19 X 88
94	P1014ZX094	KNOB 3/8-24
95	P1014ZX095	LOCK WASHER 5/16
96	P1014ZX096	SET SCREW 5/16-18 X 3/4
97	P1014ZX097	FENDER WASHER 5/16 X 21 X 2
98	P1014ZX098	HEX NUT 3/8-24
99	P1014ZX099	GRAPHITE PAD 6"W X 17"L
100	P1014ZX100	DUST PORT
101	P1014ZX101	FENDER WASHER 3/8"
102	P1014ZX102	BELT DIRECTION ARROW
103	P1014ZX103	TABLE TILT POINTER
105	P1014ZX105	HEX NUT 3/8-16
106	P1014ZX106	LOCK WASHER 5MM
107	P1014ZX107	HEX BOLT 1/4-20 X 1/2
108	P1014ZX108	FLAT WASHER 1/4
114A	P1014ZX114A	IDLER ROLLER GUARD V2.03.08
114A-1	P1014ZX114A-1	SLEEVE GUARD
115	P1014ZX115	LOCK KNOB 1/4-20
116	P1014ZX116	FLAT WASHER 1/4
117	P1014ZX117	FLAT WASHER 5/16
119	P1014ZX119	DUST PORT (ABS) 2-1/2"
120	P1014ZX120	MOTOR LABEL
126	P1014ZX126	LOCK KNOB 10-32
127	P1014ZX127	FLAT WASHER #10
128	P1014ZX128	PHLP HD SCR 10-24 X 3/8
137	P1014ZX137	LOCK WASHER #10



G1014ZX Cabinet

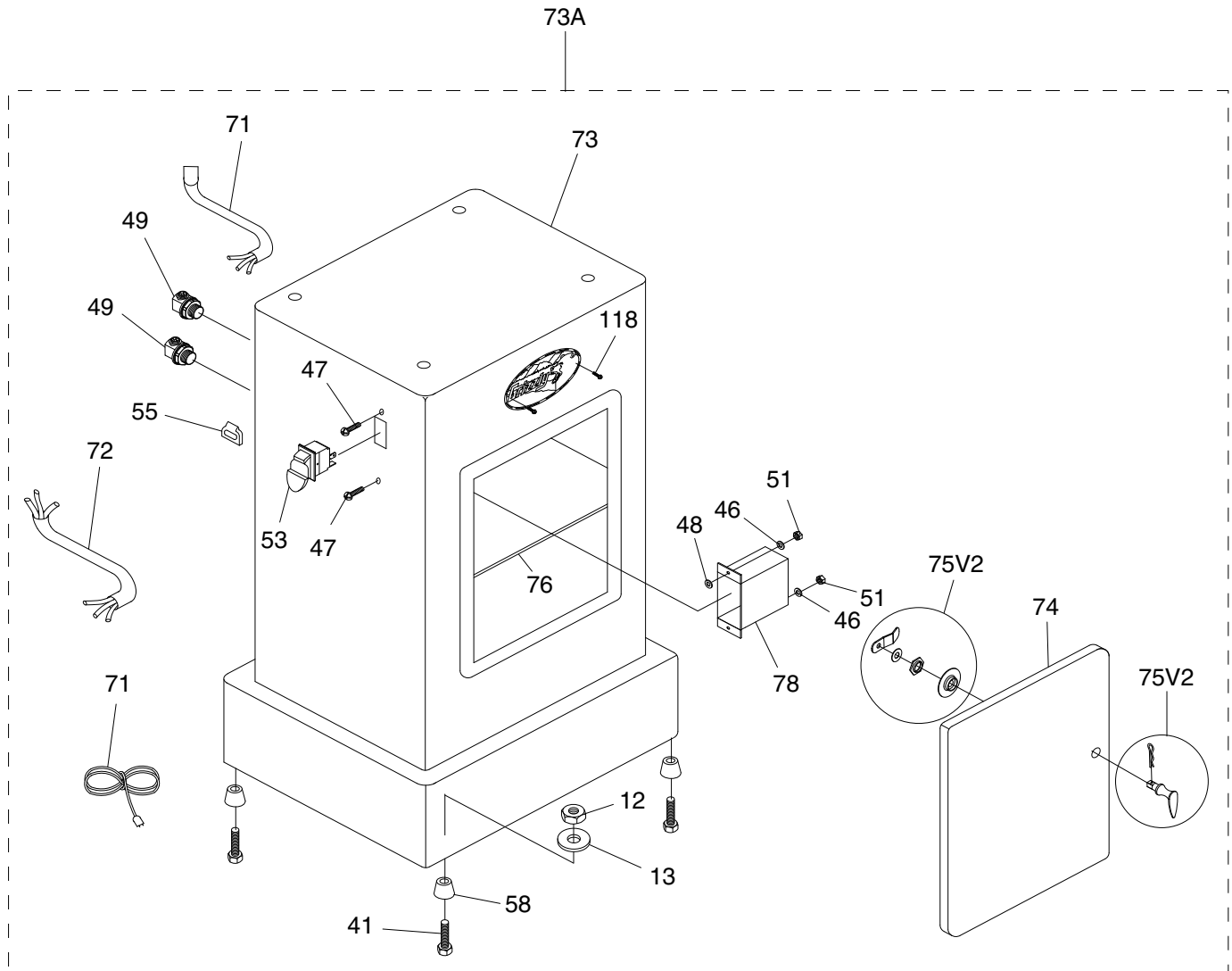

REF	PART #	DESCRIPTION
12	P1014ZX012	HEX NUT 5/16-18
13	P1014ZX013	FLAT WASHER 5/16
32	P1014ZX032	HEX BOLT 5/16-18 X 1/2
41	P1014ZX041	HEX BOLT 5/16-18 X 1
46	P1014ZX046	FLAT WASHER #10
47	P1014ZX047	FLANGE SCREW 10-24 X 3/8
48	P1014ZX048	EXT TOOTH WASHER #10
49	P1014ZX049	STRAIN RELIEF M14 TYPE-1 SNAP-IN
51	P1014ZX051	HEX NUT 10-24
53	P1014ZX053	SAFETY PADDLE SWITCH
55	P1014ZX055	PADDLE SWITCH KEY

REF	PART #	DESCRIPTION
58	P1014ZX058	RUBBER FOOT
71	P1014ZX071	POWER CORD 16G 3W 73" 5-15P
72	P1014ZX072	MOTOR CORD 1 FEMALE
72-1	P1014ZX072-1	MOTOR CORD 2 MALE
73	P1014ZX073	CABINET
73A	P1014ZX073A	COMPLETE STAND ASSY BOX 2
74	P1014ZX074	CABINET DOOR
75V2	P1014ZX075V2	DOOR LATCH SYSTEM V2.11.13
76	P1014ZX076	SHELF
78	P1014ZX078	SWITCH HOUSING
118	P1014ZX118	TAP SCREW #5 X 3/8



G1014ZX Labels & Cosmetics

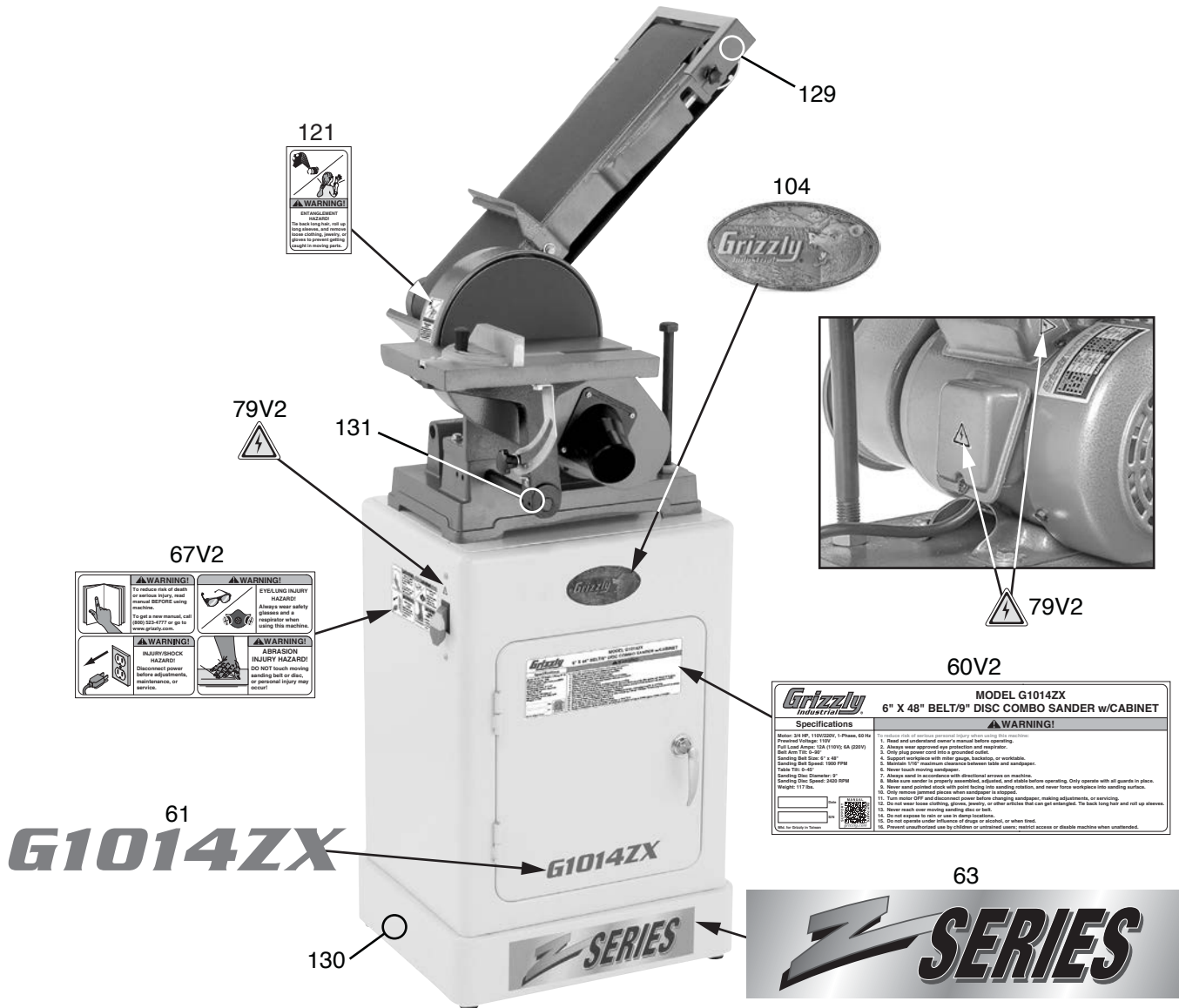

REF	PART #	DESCRIPTION
60V2	P1014ZX060V2	MACHINE ID LABEL V2.08.22
61	P1014ZX061	MODEL NUMBER LABEL
63	P1014ZX063	Z-SERIES LABEL
67V2	P1014ZX067V2	COMBO WARNING LABEL V2.08.22
79V2	P1014ZX079V2	ELECTRICITY LABEL V2.08.22

REF	PART #	DESCRIPTION
104	P1014ZX104	GRIZZLY NAMEPLATE- SMALL
121	P1014ZX121	ENTANGLEMENT LABEL
129	P1014ZX129	TOUCH-UP PAINT, GRIZZLY GREEN
130	P1014ZX130	TOUCH-UP PAINT, GREY PUTTY
131	P1014ZX131	TOUCH-UP PAINT, GLOSSY BLACK

⚠ WARNING

Safety labels help reduce the risk of serious injury caused by machine hazards. If any label comes off or becomes unreadable, the owner of this machine **MUST** replace it in the original location before resuming operations. For replacements, contact (800) 523-4777 or www.grizzly.com.



WARRANTY & RETURNS

Grizzly Industrial, Inc. warrants every product it sells for a period of **1 year** to the original purchaser from the date of purchase. This warranty does not apply to defects due directly or indirectly to misuse, abuse, negligence, accidents, repairs or alterations or lack of maintenance. This is Grizzly's sole written warranty and any and all warranties that may be implied by law, including any merchantability or fitness, for any particular purpose, are hereby limited to the duration of this written warranty. We do not warrant or represent that the merchandise complies with the provisions of any law or acts unless the manufacturer so warrants. In no event shall Grizzly's liability under this warranty exceed the purchase price paid for the product and any legal actions brought against Grizzly shall be tried in the State of Washington, County of Whatcom.

We shall in no event be liable for death, injuries to persons or property or for incidental, contingent, special, or consequential damages arising from the use of our products.

The manufacturers reserve the right to change specifications at any time because they constantly strive to achieve better quality equipment. We make every effort to ensure that our products meet high quality and durability standards and we hope you never need to use this warranty.

In the event you need to use this warranty, contact us by mail or phone and give us all the details. We will then issue you a "Return Number," which must be clearly posted on the outside as well as the inside of the carton. We will not accept any item back without this number. Proof of purchase must accompany the merchandise.

Please feel free to write or call us if you have any questions about the machine or the manual.

Thank you again for your business and continued support. We hope to serve you again soon.

To take advantage of this warranty, you must register it at <https://www.grizzly.com/forms/warranty>, or you can scan the QR code below to be automatically directed to our warranty registration page. Enter all applicable information for the product.



grizzly.com[®]
TOOL WEBSITE

Buy Direct and Save with Grizzly[®] – Trusted, Proven and a Great Value!
~Since 1983~

*Visit Our Website Today For
Current Specials!*

**ORDER
24 HOURS A DAY!
1-800-523-4777**

