

# **Grizzly** **Industrial, Inc.**®

## **MODEL G0796/G0797 VERTICAL MILL w/POWER FEED & DRO OWNER'S MANUAL** *(For models manufactured since 8/18)*



COPYRIGHT © AUGUST, 2015 BY GRIZZLY INDUSTRIAL, INC., REVISED DECEMBER, 2020 (MN)  
**WARNING: NO PORTION OF THIS MANUAL MAY BE REPRODUCED IN ANY SHAPE  
OR FORM WITHOUT THE WRITTEN APPROVAL OF GRIZZLY INDUSTRIAL, INC.**  
#WK17430 PRINTED IN CHINA

V3.12.20



## **WARNING!**

**This manual provides critical safety instructions on the proper setup, operation, maintenance, and service of this machine/tool. Save this document, refer to it often, and use it to instruct other operators.**

**Failure to read, understand and follow the instructions in this manual may result in fire or serious personal injury—including amputation, electrocution, or death.**

**The owner of this machine/tool is solely responsible for its safe use. This responsibility includes but is not limited to proper installation in a safe environment, personnel training and usage authorization, proper inspection and maintenance, manual availability and comprehension, application of safety devices, cutting/sanding/grinding tool integrity, and the usage of personal protective equipment.**

**The manufacturer will not be held liable for injury or property damage from negligence, improper training, machine modifications or misuse.**



## **WARNING!**

**Some dust created by power sanding, sawing, grinding, drilling, and other construction activities contains chemicals known to the State of California to cause cancer, birth defects or other reproductive harm. Some examples of these chemicals are:**

- **Lead from lead-based paints.**
- **Crystalline silica from bricks, cement and other masonry products.**
- **Arsenic and chromium from chemically-treated lumber.**

**Your risk from these exposures varies, depending on how often you do this type of work. To reduce your exposure to these chemicals: Work in a well ventilated area, and work with approved safety equipment, such as those dust masks that are specially designed to filter out microscopic particles.**

# Table of Contents

<b>INTRODUCTION</b> .....	<b>2</b>	<b>SECTION 5: ACCESSORIES</b> .....	<b>46</b>
Contact Info.....	2	<b>SECTION 6: MAINTENANCE</b> .....	<b>49</b>
Manual Accuracy .....	2	Schedule.....	49
Front View Identification .....	3	Cleaning & Protecting .....	49
Model G0796 Headstock Identification.....	4	Lubrication .....	50
Model G0797 Headstock Identification.....	5	Machine Storage.....	53
Controls & Components.....	6	<b>SECTION 7: SERVICE</b> .....	<b>54</b>
G0796 Machine Data Sheet .....	9	Troubleshooting .....	54
G0797 Machine Data Sheet .....	11	Adjusting Gibs.....	57
<b>SECTION 1: SAFETY</b> .....	<b>13</b>	Adjusting Leadscrew Backlash .....	58
Safety Instructions for Machinery .....	13	Tramming Spindle.....	60
Additional Safety for Milling Machines.....	15	Replacing Belts & Brake Shoes.....	62
<b>SECTION 2: POWER SUPPLY</b> .....	<b>16</b>	<b>SECTION 8: WIRING</b> .....	<b>67</b>
Converting Voltage to 440V.....	19	Wiring Safety Instructions .....	67
<b>SECTION 3: SETUP</b> .....	<b>20</b>	G0796 Motor & Switch Wiring .....	68
Needed for Setup.....	20	G0797 Motor & Switch Wiring (220V).....	69
Unpacking .....	20	G0797 Motor & Switch Wiring (440V).....	70
Inventory .....	21	<b>SECTION 9: PARTS</b> .....	<b>71</b>
Cleanup.....	22	G0796 Main Body .....	71
Site Considerations.....	23	G0796 Table Leadscrews.....	73
Lifting & Placing .....	24	G0796 Headstock .....	74
Leveling.....	25	G0796 Downfeed.....	76
Anchoring to Floor .....	25	G0796 One Shot Oiler .....	79
Assembly .....	26	G0796 Accessories.....	80
Power Connection (G0796) .....	27	G0796 Labels & Cosmetics .....	81
Power Connection (G0797 220V).....	28	G0797 Main Body .....	82
Power Connection (G0797 440V).....	28	G0797 Table Leadscrews.....	84
Test Run .....	29	G0797 Headstock .....	85
Spindle Break-In .....	31	G0797 Headstock Gearing .....	87
Inspections & Adjustments .....	31	G0797 Downfeed.....	89
<b>SECTION 4: OPERATIONS</b> .....	<b>32</b>	G0797 One Shot Oiler .....	92
Operation Overview .....	32	G0797 Accessories.....	93
Positioning Table .....	33	G0797 Labels & Cosmetics .....	94
Positioning Headstock .....	35	<b>WARRANTY &amp; RETURNS</b> .....	<b>97</b>
Positioning Ram.....	36		
Spindle Speed.....	37		
Spindle Downfeed.....	40		
Spindle Brake.....	44		
Loading/Unloading Tooling .....	44		

# INTRODUCTION

## Contact Info

We stand behind our machines! If you have questions or need help, contact us with the information below. Before contacting, make sure you get the **serial number** and **manufacture date** from the machine ID label. This will help us help you faster.

Grizzly Technical Support  
1815 W. Battlefield  
Springfield, MO 65807  
Phone: (570) 546-9663  
Email: techsupport@grizzly.com

We want your feedback on this manual. What did you like about it? Where could it be improved? Please take a few minutes to give us feedback.

Grizzly Documentation Manager  
P.O. Box 2069  
Bellingham, WA 98227-2069  
Email: manuals@grizzly.com

### **WARNING**

Like all machinery there is potential danger when operating this machine. Accidents are frequently caused by lack of familiarity or failure to pay attention. Use this machine with respect and caution to decrease the risk of operator injury. If normal safety precautions are overlooked or ignored, serious personal injury may occur.

## Manual Accuracy

We are proud to provide a high-quality owner's manual with your new machine!

We made every effort to be exact with the instructions, specifications, drawings, and photographs in this manual. Sometimes we make mistakes, but our policy of continuous improvement also means that **sometimes the machine you receive is slightly different than shown in the manual.**

If you find this to be the case, and the difference between the manual and machine leaves you confused or unsure about something, check our website for an updated version. We post current manuals and manual updates for free on our website at **www.grizzly.com**.

Alternatively, you can call our Technical Support for help. Before calling, make sure you write down the **Manufacture Date** and **Serial Number** from the machine ID label (see below). This information is required for us to provide proper tech support, and it helps us determine if updated documentation is available for your machine.

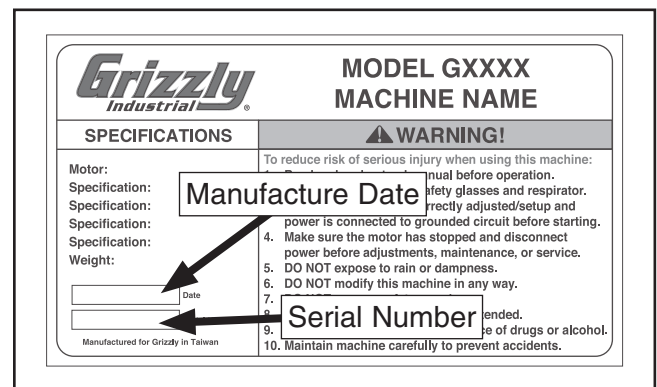

**Grizzly Industrial** MODEL GXXXX MACHINE NAME

**WARNING!**

**SPECIFICATIONS**

Motor: \_\_\_\_\_  
Specification: \_\_\_\_\_  
Specification: \_\_\_\_\_  
Specification: \_\_\_\_\_  
Weight: \_\_\_\_\_

To reduce risk of serious injury when using this machine:  
1. Read manual before operation.  
2. Wear safety glasses and respirator.  
3. Make sure safety is correctly adjusted/setup and power is connected to grounded circuit before starting.  
4. Make sure the motor has stopped and disconnect power before adjustments, maintenance, or service.  
5. DO NOT expose to rain or dampness.  
6. DO NOT modify this machine in any way.  
7. \_\_\_\_\_  
8. \_\_\_\_\_  
9. \_\_\_\_\_  
10. Maintain machine carefully to prevent accidents.

Manufacture Date: \_\_\_\_\_  
Serial Number: \_\_\_\_\_

Manufactured for Grizzly in Taiwan



# Front View Identification

Become familiar with the names and locations of the controls and features shown below to better understand the instructions in this manual.

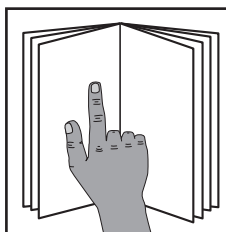
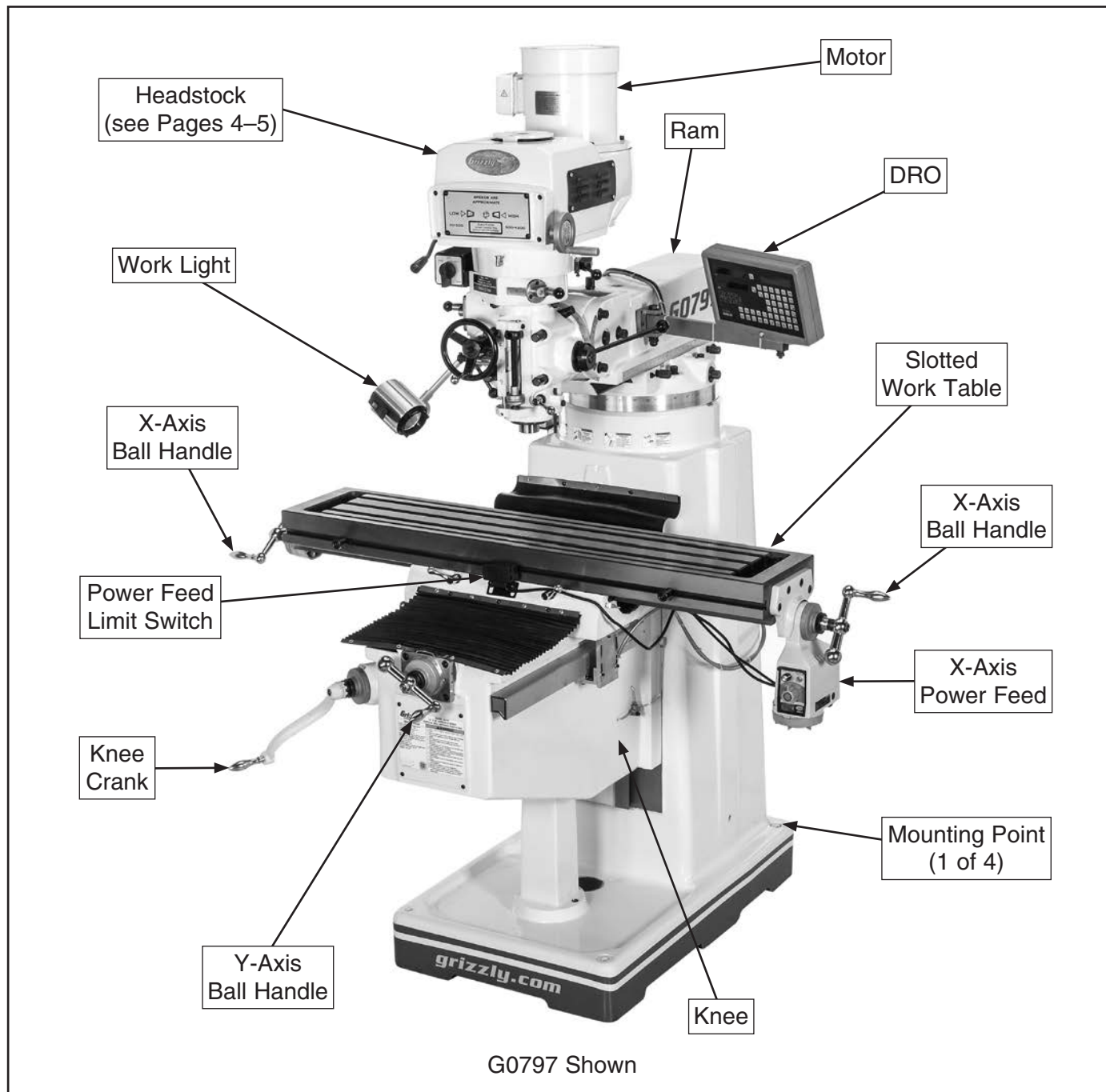

## **⚠️ WARNING**

To reduce your risk of serious injury, read this entire manual **BEFORE** using machine.



# Model G0796 Headstock Identification

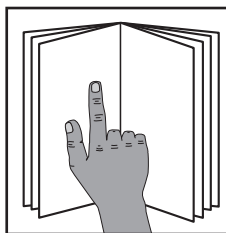
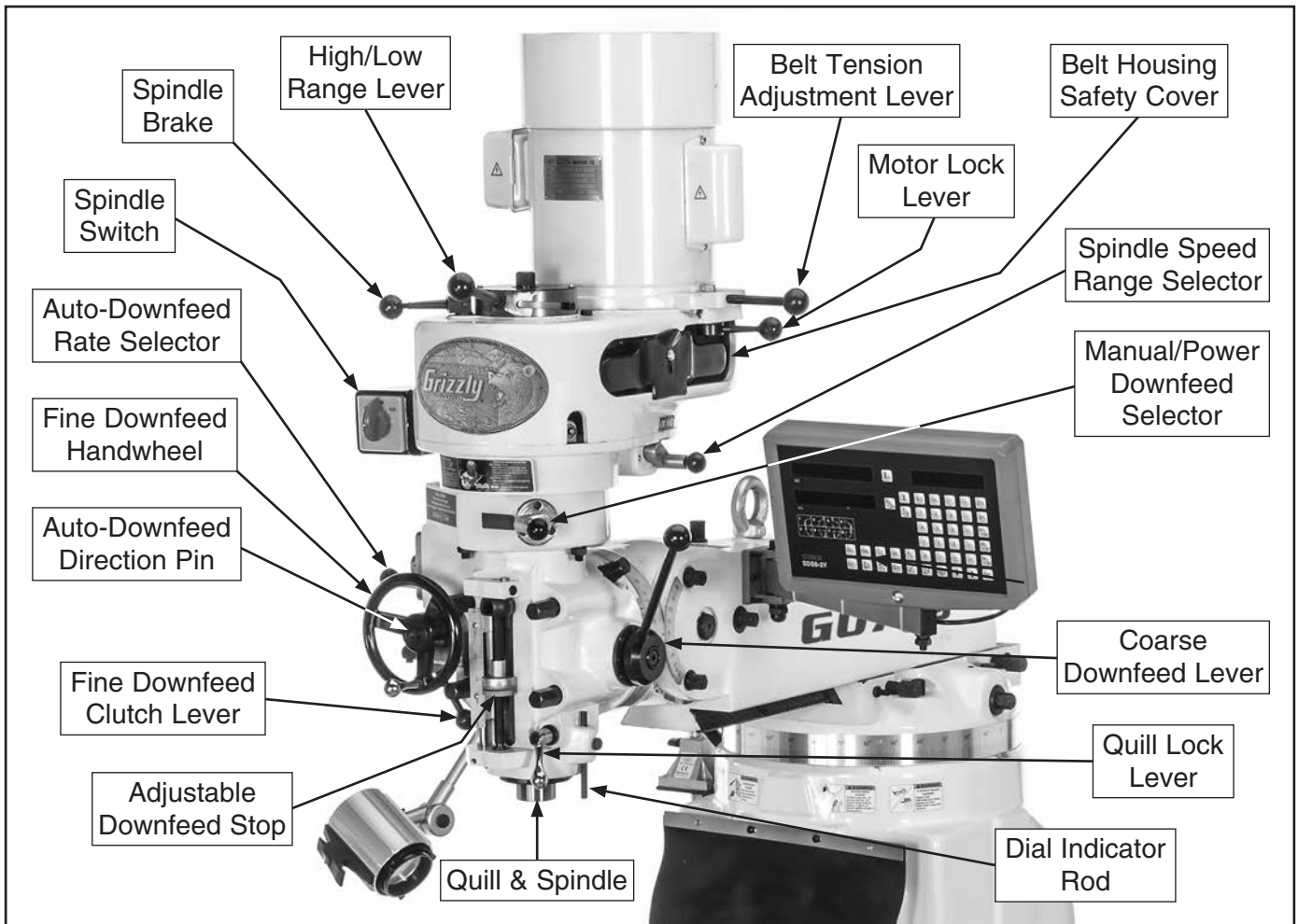

## **⚠️ WARNING**

To reduce your risk of serious injury, read this entire manual **BEFORE** using machine.



# Model G0797 Headstock Identification

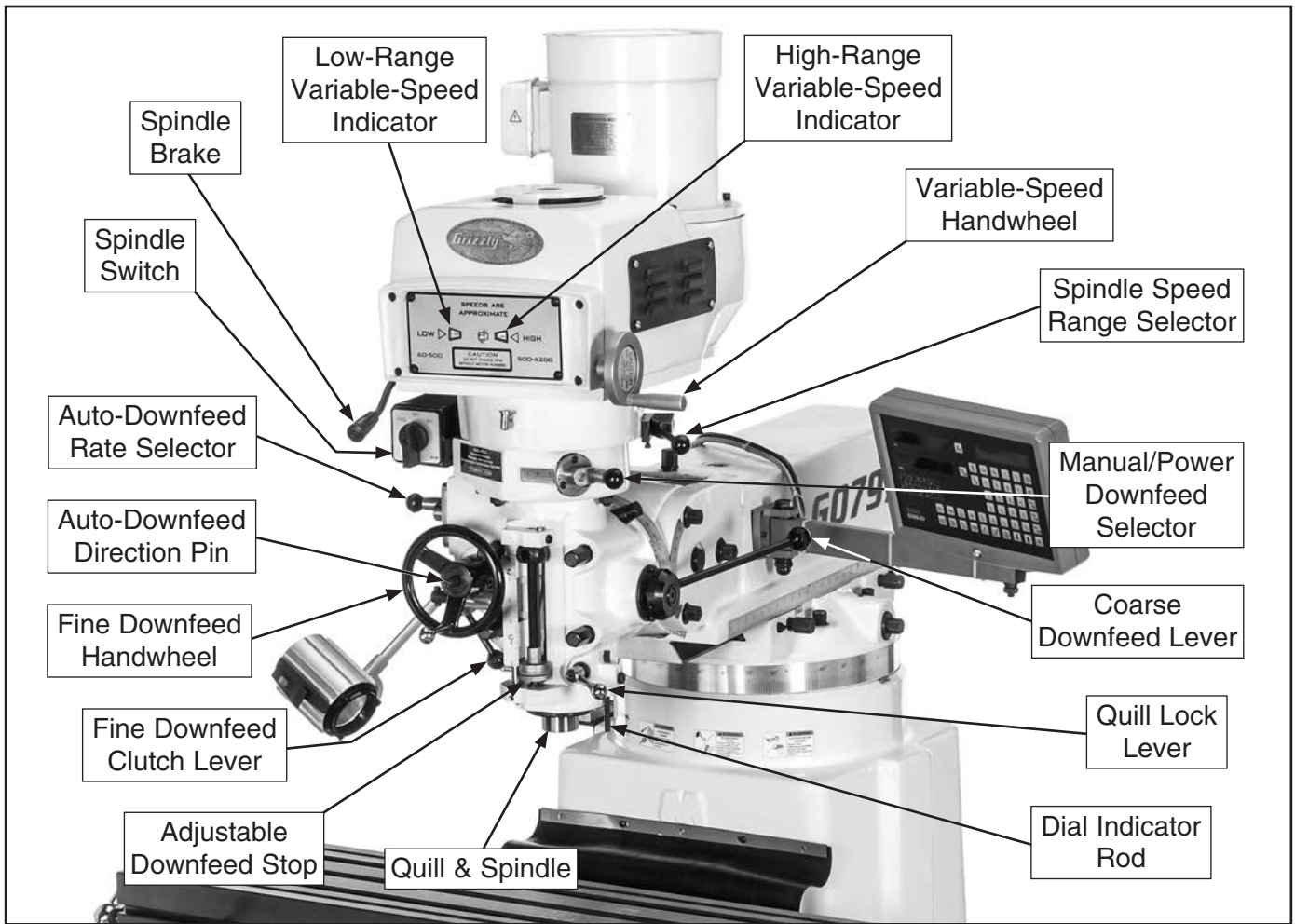

	<p><b>⚠ WARNING</b> To reduce your risk of serious injury, read this entire manual <b>BEFORE</b> using machine.</p>
---	---



# Controls & Components



Refer to **Figures 1–5** and the following descriptions to become familiar with the basic controls and components of this machine. Understanding these items and how they work will help you understand the rest of the manual and stay safe when operating this machine.

## Upper Headstock (G0796)

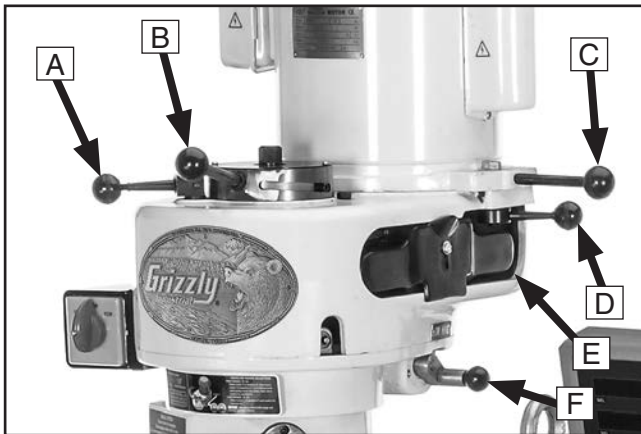

**Figure 1.** Model G0796 upper headstock controls and components.

- A. Spindle Brake Lever:** Quickly stops spindle *AFTER* power to spindle is turned **OFF**.
- B. High/Low Range Lever:** Selects between low (80 RPM–325 RPM) and high (660 RPM–2720 RPM) spindle speed ranges.
- C. Belt Tension Adjustment Lever:** Adjusts V-belt tension by moving position of motor.
- D. Motor Lock Lever:** Locks motor position to secure belt tension.
- E. Belt Safety Cover:** Protects user from entanglement during operation. Remove to access V-belt when changing spindle speed.

- F. Spindle Speed Range Selector:** Used in conjunction with high/low range lever. Engages back gear for low (80–325 RPM), and disengages back gear for high (660–2720 RPM) spindle speed ranges.

**Note:** When engaged, back gear reverses spindle rotation, causing spindle switch settings to be reversed in low range (see **Spindle Switch** on **Page 7** for more information).

## Upper Headstock (G0797)

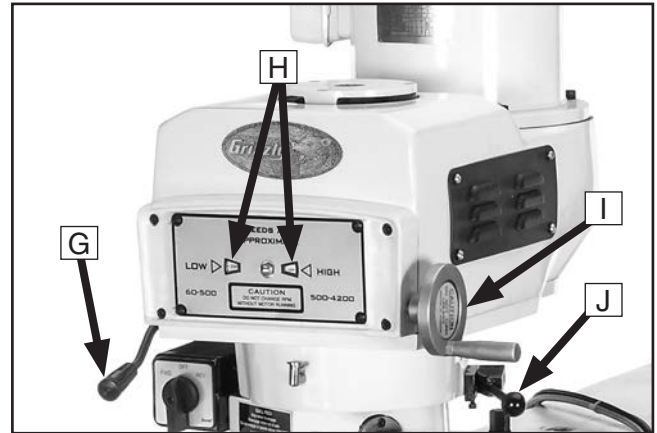

**Figure 2.** Model G0797 upper headstock controls and components.

- G. Spindle Brake Lever:** Quickly stops spindle *AFTER* power to spindle is turned **OFF**.
- H. Variable-Speed Indicators:** Indicate spindle speed in high and low range.
- I. Variable-Speed Handwheel:** Selects desired spindle speed within high or low range.
- J. Spindle Speed Range Selector:** Engages back gear for low (60 RPM–500 RPM), and disengages back gear for high (500 RPM–4200 RPM) spindle speed ranges.

**Note:** When engaged, back gear reverses spindle rotation, causing spindle switch settings to be reversed in low range (see **Spindle Switch** on **Page 7** for more information).





## Lower Headstock

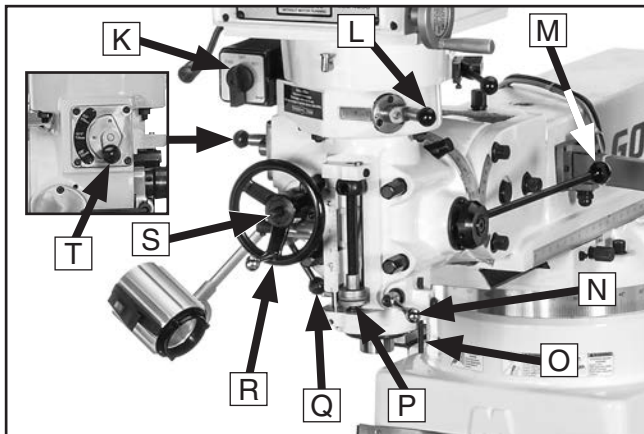

**Figure 3.** Lower headstock controls and components (Model G0797 shown).

- K. Spindle Switch:** Controls forward/reverse direction of spindle rotation.

**Note:** Spindle switch direction settings will be reversed in low range due to back gear. Therefore, in low range, FORWARD will cause reverse spindle rotation, and REVERSE will cause forward rotation.

- L. Manual/Power Downfeed Selector:** Selects between manual and power downfeed.
- M. Coarse Downfeed Lever:** Quickly moves quill downward manually and automatically retracts spindle to top position when released. Typically used for drilling operations.
- N. Quill Lock Lever:** Locks quill in vertical position.
- O. Dial Indicator Rod:** Used to hold dial test indicator when tramping spindle.
- P. Adjustable Downfeed Stop:** Limits depth of quill travel. Dial is graduated in increments of 0.001". Typically used for repeat operations.
- Q. Fine/Auto Downfeed Clutch Lever:** Engages fine/auto-downfeed gears.
- R. Fine Downfeed Handwheel:** Manually controls slow spindle downfeed for fine Z-axis control.
- S. Auto-Downfeed Direction Pin:** Starts, stops, and reverses auto-downfeed direction.

- T. Auto-Downfeed Rate Selector:** Selects one of the three auto-downfeed rates:

0.0015 in/rev  
0.003 in/rev  
0.006 in/rev

## Table

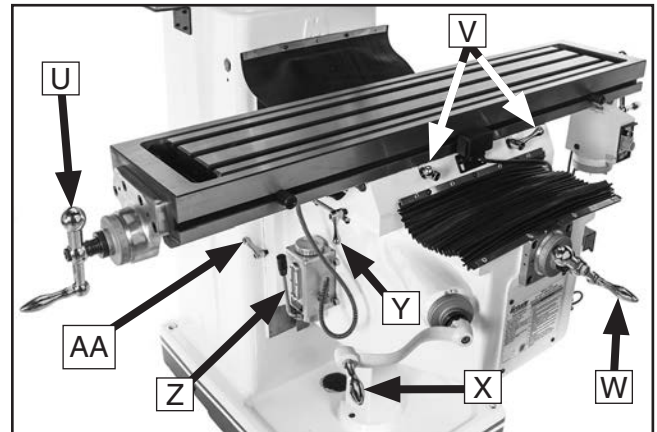

**Figure 4.** Table controls and components.

- U. X-Axis Ball Handle:** Manually moves table along X-axis (left and right).
- V. X-Axis Locks:** Tightens to prevent X-axis table movement for increased rigidity during operations where the X-axis should not move.
- W. Y-Axis Ball Handle:** Manually moves table along Y-axis (front and back).
- X. Knee Crank:** Manually moves table along Z-axis (up and down).
- Y. Y-Axis Lock:** Tightens to prevent Y-axis table movement for increased rigidity during operations where the Y-axis should not move.
- Z. One Shot Oiler:** Lubricates X-, Y-, and Z-axis table ways.
- AA. Z-Axis Lock (1 of 2):** Tightens to prevent Z-axis table movement for increased rigidity during operations where the Z-axis should not move.



## X-Axis Power Feed Identification

The mill is equipped with a power feed unit for X-axis table movement. Refer to **Figure 5** and the descriptions below to understand the functions of the various components of the power feed system.

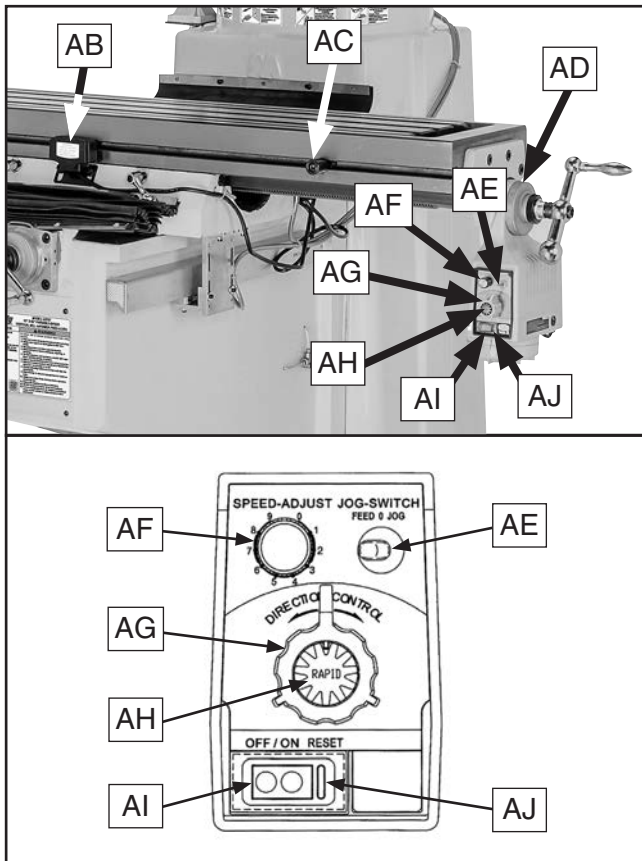

**Figure 5.** X-axis power feed controls.

**AB. Power Feed Limit Switch:** Stops table movement when either of the switch side plungers are pressed by limit stops.

**AC. Limit Stop:** Restricts table movement by its positioning along front of table.

**AD. Graduated Index Ring:** Displays distance of table travel in 0.001" increments, with one full revolution equal to 0.200" of table travel.

**AE. Feed/Jog Switch:** In left (feed) position, it enables power feed to operate normally.

While pressing switch to right (jog position), table moves in selected direction until switch is released.

In middle position ("0"), table movement is disabled.

**AF. Speed Dial:** Controls speed of power feed. Rotating dial clockwise causes table to move faster.

**AG. Direction Knob:** Selects direction of table movement. Middle position is neutral.

**AH. Rapid Traverse Button:** When pressed, moves table at full speed when already in motion.

**AI. ON/OFF Button:** Turns power feed **ON** and **OFF**.

**AJ. Circuit Breaker Reset Button:** Resets internal circuit breaker if unit is overloaded and shuts down.





# MACHINE DATA SHEET

Customer Service #: (570) 546-9663 · To Order Call: (800) 523-4777 · Fax #: (800) 438-5901

## MODEL G0796 9" X 49" VERTICAL MILL WITH POWER FEED AND DRO

### Product Dimensions:

Weight..... 2249 lbs.  
 Width (side-to-side) x Depth (front-to-back) x Height..... 83 x 62 x 84 in.  
 Footprint (Length x Width)..... 41 x 27 in.

### Shipping Dimensions:

Type..... Wood Crate  
 Content..... Machine  
 Weight..... 2580 lbs.  
 Length x Width x Height..... 60 x 55 x 80 in.  
 Must Ship Upright..... Yes

### Electrical:

Power Requirement..... 220V, Single-Phase, 60 Hz  
 Full-Load Current Rating..... 19.5A  
 Minimum Circuit Size..... 30A  
 Connection Type..... Cord & Plug  
 Power Cord Included..... No  
 Recommended Power Cord..... "S" Type, 3-Wire, 12 AWG, 300VAC  
 Plug Included..... No  
 Recommended Plug Type..... L6-30  
 Switch Type..... Forward/Reverse Switch

### Motors:

#### Main

Horsepower..... 3 HP  
 Phase..... Single-Phase  
 Amps..... 19.5A  
 Speed..... 1720 RPM  
 Type..... TEFC Induction  
 Power Transfer ..... V-Belt Drive  
 Bearings..... Shielded & Permanently Lubricated



**Main Specifications:**

**Operation Info**

Spindle Travel.....	5 in.
Max Distance Spindle to Column.....	21 in.
Max Distance Spindle to Table.....	15-7/8 in.
Longitudinal Table Travel (X-Axis).....	28 in.
Longitudinal Leadscrew (X-Axis).....	52 in.
Cross Table Travel (Y-Axis).....	12 in.
Vertical Table Travel (Z-Axis).....	16 in.
Ram Travel.....	12 in.
Turret or Column Swivel (Left /Right).....	360 deg.
Head Tilt (Left/Right).....	90 deg.
Head Tilt (Front/Back).....	45 deg.
Drilling Capacity for Cast Iron.....	1-1/2 in.
Drilling Capacity for Steel.....	1-1/4 in.
End Milling Capacity.....	1 in.
Face Milling Capacity.....	3 in.

**Table Info**

Table Length.....	49 in.
Table Width.....	9 in.
Table Thickness.....	3-3/4 in.
Number of T-Slots.....	3
T-Slot Size.....	5/8 in.
T-Slots Centers.....	2-1/2 in.
Number of Longitudinal Feeds.....	Variable
X-Axis Table Power Feed Rate.....	0 – 3.41 FPM
X/Y-Axis Travel per Handwheel Revolution.....	0.200 in.
Z-Axis Travel per Handwheel Revolution.....	0.100 in.

**Spindle Info**

Spindle Taper.....	R-8
Number of Vertical Spindle Speeds.....	8
Range of Vertical Spindle Speeds.....	80 – 2720 RPM
Quill Diameter.....	3-3/8 in.
Quill Feed Rates.....	0.0015, 0.003, 0.006 in./rev.
Drawbar Thread Size.....	7/16-20
Drawbar Length.....	18-1/2 in.
Spindle Bearings.....	Angular Contact Ball Bearings

**Construction**

Spindle Housing/Quill.....	Cast Iron
Table.....	Cast Iron
Head.....	Cast Iron
Column/Base.....	Cast Iron
Base.....	Cast Iron
Stand.....	Cast Iron
Paint Type/Finish.....	Enamel

**Other Specifications:**

Country of Origin .....	China
Warranty .....	1 Year
Approximate Assembly & Setup Time .....	90 Minutes
Serial Number Location .....	ID Label
ISO 9001 Factory .....	Yes





# MACHINE DATA SHEET

Customer Service #: (570) 546-9663 · To Order Call: (800) 523-4777 · Fax #: (800) 438-5901

## MODEL G0797 10" X 50" 3 HP VARIABLE-SPEED VERTICAL MILL WITH POWER FEED AND DRO

### Product Dimensions:

Weight..... 2470 lbs.  
 Width (side-to-side) x Depth (front-to-back) x Height..... 100 x 85 x 88 in.  
 Footprint (Length x Width)..... 48 x 33 in.

### Shipping Dimensions:

Type..... Wood Crate  
 Content..... Machine  
 Weight..... 3021 lbs.  
 Length x Width x Height..... 62 x 61 x 82 in.  
 Must Ship Upright..... Yes

### Electrical:

Power Requirement..... 220V or 440V, 3-Phase, 60 Hz  
 Prewired Voltage..... 220V  
 Full-Load Current Rating..... 6.4A at 220V, 3.2A at 440V  
 Minimum Circuit Size..... 15A  
 Connection Type..... Cord at 220V, Permanent (Hardwire) at 440V  
 Power Cord Included..... Yes  
 Power Cord Length..... 72 in.  
 Power Cord Gauge..... 14 AWG  
 Plug Included..... No  
 Recommended Plug Type..... 15-15 for 220V  
 Switch Type..... Forward/Reverse Switch

### Motors:

#### Main

Horsepower..... 3 HP  
 Phase..... 3-Phase  
 Amps..... 6.4A/3.2A  
 Speed..... 1720 RPM  
 Type..... TEFC Induction  
 Power Transfer ..... Belt  
 Bearings..... Shielded & Permanently Lubricated



**Main Specifications:**

**Operation Info**

Spindle Travel.....	5 in.
Max Distance Spindle to Column.....	27-1/2 in.
Max Distance Spindle to Table.....	19-1/4 in.
Longitudinal Table Travel (X-Axis).....	30 in.
Longitudinal Leadscrew (X-Axis).....	52 in.
Cross Table Travel (Y-Axis).....	14 in.
Vertical Table Travel (Z-Axis).....	15 in.
Ram Travel.....	18-1/2 in.
Turret or Column Swivel (Left /Right).....	360 deg.
Head Tilt (Left/Right).....	90 deg.
Head Tilt (Front/Back).....	45 deg.
Drilling Capacity for Cast Iron.....	1-1/2 in.
Drilling Capacity for Steel.....	1-1/4 in.
End Milling Capacity.....	1 in.
Face Milling Capacity.....	3 in.

**Table Info**

Table Length.....	50 in.
Table Width.....	10 in.
Table Thickness.....	4-1/8 in.
Number of T-Slots.....	3
T-Slot Size.....	5/8 in.
T-Slots Centers.....	2-1/2 in.
Number of Longitudinal Feeds.....	Variable
X-Axis Table Power Feed Rate.....	0 – 3.41 FPM
X/Y-Axis Travel per Handwheel Revolution.....	0.200 in.
Z-Axis Travel per Handwheel Revolution.....	0.100 in.

**Spindle Info**

Spindle Taper.....	R-8
Number of Vertical Spindle Speeds.....	Variable
Range of Vertical Spindle Speeds.....	60 – 4200 RPM
Quill Diameter.....	3-5/16 in.
Quill Feed Rates.....	0.0015, 0.003, 0.006, in./rev.
Drawbar Thread Size.....	7/16-20
Drawbar Length.....	18-1/2 in.
Spindle Bearings.....	Angular Contact Bearings

**Construction**

Spindle Housing/Quill.....	Cast Iron
Table.....	Cast Iron
Head.....	Cast Iron
Column/Base.....	Cast Iron
Base.....	Cast Iron
Paint Type/Finish.....	Enamel

**Other Specifications:**

Country of Origin .....	China
Warranty .....	1 Year
Approximate Assembly & Setup Time .....	90 Minutes
Serial Number Location .....	ID Label
ISO 9001 Factory .....	Yes



# SECTION 1: SAFETY

## For Your Own Safety, Read Instruction Manual Before Operating This Machine

The purpose of safety symbols is to attract your attention to possible hazardous conditions. This manual uses a series of symbols and signal words intended to convey the level of importance of the safety messages. The progression of symbols is described below. Remember that safety messages by themselves do not eliminate danger and are not a substitute for proper accident prevention measures. Always use common sense and good judgment.

**⚠ DANGER** Indicates an imminently hazardous situation which, if not avoided, **WILL** result in death or serious injury.

**⚠ WARNING** Indicates a potentially hazardous situation which, if not avoided, **COULD** result in death or serious injury.

**⚠ CAUTION** Indicates a potentially hazardous situation which, if not avoided, **MAY** result in minor or moderate injury. It may also be used to alert against unsafe practices.

**NOTICE** Alerts the user to useful information about proper operation of the machine to avoid machine damage.

## Safety Instructions for Machinery

### ⚠ WARNING

**OWNER'S MANUAL.** Read and understand this owner's manual **BEFORE** using machine.

**TRAINED OPERATORS ONLY.** Untrained operators have a higher risk of being hurt or killed. Only allow trained/supervised people to use this machine. When machine is not being used, disconnect power, remove switch keys, or lock-out machine to prevent unauthorized use—especially around children. Make your workshop kid proof!

**DANGEROUS ENVIRONMENTS.** Do not use machinery in areas that are wet, cluttered, or have poor lighting. Operating machinery in these areas greatly increases the risk of accidents and injury.

**MENTAL ALERTNESS REQUIRED.** Full mental alertness is required for safe operation of machinery. Never operate under the influence of drugs or alcohol, when tired, or when distracted.

**ELECTRICAL EQUIPMENT INJURY RISKS.** You can be shocked, burned, or killed by touching live electrical components or improperly grounded machinery. To reduce this risk, only allow qualified service personnel to do electrical installation or repair work, and always disconnect power before accessing or exposing electrical equipment.

**DISCONNECT POWER FIRST.** Always disconnect machine from power supply **BEFORE** making adjustments, changing tooling, or servicing machine. This prevents an injury risk from unintended startup or contact with live electrical components.

**EYE PROTECTION.** Always wear ANSI-approved safety glasses or a face shield when operating or observing machinery to reduce the risk of eye injury or blindness from flying particles. Everyday eyeglasses are **NOT** approved safety glasses.



# WARNING

**WEARING PROPER APPAREL.** Do not wear clothing, apparel or jewelry that can become entangled in moving parts. Always tie back or cover long hair. Wear non-slip footwear to reduce risk of slipping and losing control or accidentally contacting cutting tool or moving parts.

**HAZARDOUS DUST.** Dust created by machinery operations may cause cancer, birth defects, or long-term respiratory damage. Be aware of dust hazards associated with each workpiece material. Always wear a NIOSH-approved respirator to reduce your risk.

**HEARING PROTECTION.** Always wear hearing protection when operating or observing loud machinery. Extended exposure to this noise without hearing protection can cause permanent hearing loss.

**REMOVE ADJUSTING TOOLS.** Tools left on machinery can become dangerous projectiles upon startup. Never leave chuck keys, wrenches, or any other tools on machine. Always verify removal before starting!

**USE CORRECT TOOL FOR THE JOB.** Only use this tool for its intended purpose—do not force it or an attachment to do a job for which it was not designed. Never make unapproved modifications—modifying tool or using it differently than intended may result in malfunction or mechanical failure that can lead to personal injury or death!

**AWKWARD POSITIONS.** Keep proper footing and balance at all times when operating machine. Do not overreach! Avoid awkward hand positions that make workpiece control difficult or increase the risk of accidental injury.

**CHILDREN & BYSTANDERS.** Keep children and bystanders at a safe distance from the work area. Stop using machine if they become a distraction.

**GUARDS & COVERS.** Guards and covers reduce accidental contact with moving parts or flying debris. Make sure they are properly installed, undamaged, and working correctly BEFORE operating machine.

**FORCING MACHINERY.** Do not force machine. It will do the job safer and better at the rate for which it was designed.

**NEVER STAND ON MACHINE.** Serious injury may occur if machine is tipped or if the cutting tool is unintentionally contacted.

**STABLE MACHINE.** Unexpected movement during operation greatly increases risk of injury or loss of control. Before starting, verify machine is stable and mobile base (if used) is locked.

**USE RECOMMENDED ACCESSORIES.** Consult this owner's manual or the manufacturer for recommended accessories. Using improper accessories will increase the risk of serious injury.

**UNATTENDED OPERATION.** To reduce the risk of accidental injury, turn machine **OFF** and ensure all moving parts completely stop before walking away. Never leave machine running while unattended.

**MAINTAIN WITH CARE.** Follow all maintenance instructions and lubrication schedules to keep machine in good working condition. A machine that is improperly maintained could malfunction, leading to serious personal injury or death.

**DAMAGED PARTS.** Regularly inspect machine for damaged, loose, or mis-adjusted parts—or any condition that could affect safe operation. Immediately repair/replace BEFORE operating machine. For your own safety, DO NOT operate machine with damaged parts!

**MAINTAIN POWER CORDS.** When disconnecting cord-connected machines from power, grab and pull the plug—NOT the cord. Pulling the cord may damage the wires inside. Do not handle cord/plug with wet hands. Avoid cord damage by keeping it away from heated surfaces, high traffic areas, harsh chemicals, and wet/damp locations.

**EXPERIENCING DIFFICULTIES.** If at any time you experience difficulties performing the intended operation, stop using the machine! Contact our Technical Support at (570) 546-9663.





# Additional Safety for Milling Machines

## WARNING

You can be seriously injured or killed by getting clothing, jewelry, or long hair entangled with rotating cutter/spindle. You can be severely cut or have fingers amputated from contact with rotating cutters. You can be blinded or struck by broken cutting tools, metal chips, workpieces, or adjustment tools thrown from the rotating spindle with great force. To reduce your risk of serious injury when operating this machine, completely heed and understand the following:

**UNDERSTAND ALL CONTROLS.** Make sure you understand the function and proper use of all controls before starting. This will help you avoid making mistakes that result in serious injury.

**AVOIDING ENTANGLEMENT.** DO NOT wear loose clothing, gloves, or jewelry, and tie back long hair. Keep all guards in place and secure. Always allow spindle to stop on its own. DO NOT stop spindle using your hand or any other object.

**WEAR FACE SHIELD.** Always wear a face shield in addition to safety glasses. This provides more complete protection for your face than safety glasses alone.

**USE CORRECT SPINDLE SPEED.** Follow recommended speeds and feeds for each size and type of cutting tool. This helps avoid tool breakage during operation and ensures best cutting results.

**INSPECT CUTTING TOOL.** Inspect cutting tools for sharpness, chips, or cracks before each use. Replace dull, chipped, or cracked cutting tools immediately.

**PROPERLY SECURE CUTTER.** Firmly secure cutting tool or drill bit so it does not fly out of spindle during operation.

**POWER DISRUPTION.** In the event of a local power outage during operation, turn spindle switch **OFF** to avoid a possible sudden startup once power is restored.

**CLEAN MACHINE SAFELY.** Metal chips or shavings can be razor sharp. DO NOT clear chips by hand or compressed air that can force chips farther into machine—use a brush or vacuum instead. Never clear chips while spindle is turning.

**SECURE WORKPIECE TO TABLE.** Clamp workpiece to table or secure in a vise mounted to table, so workpiece cannot unexpectedly shift or spin during operation. NEVER hold workpiece by hand during operation.

**PROPERLY MAINTAIN MACHINE.** Keep machine in proper working condition to help ensure that it functions safely and all guards and other components work as intended. Perform routine inspections and all necessary maintenance. Never operate machine with damaged or worn parts that can break or result in unexpected movement during operation.

**DISCONNECT POWER FIRST.** To reduce risk of electrocution or injury from unexpected startup, make sure mill/drill is turned **OFF**, disconnected from power, and all moving parts have come to a complete stop before changing cutting tools or starting any inspection, adjustment, or maintenance procedure.

**REMOVE CHUCK KEY & SPINDLE TOOLS.** Always remove chuck key, drawbar wrench, and other tools used on the spindle immediately after use. This will prevent them from being thrown by the spindle upon startup.



# SECTION 2: POWER SUPPLY

## Availability

Before installing the machine, consider the availability and proximity of the required power supply circuit. If an existing circuit does not meet the requirements for this machine, a new circuit must be installed. To minimize the risk of electrocution, fire, or equipment damage, installation work and electrical wiring must be done by an electrician or qualified service personnel in accordance with all applicable codes and standards.

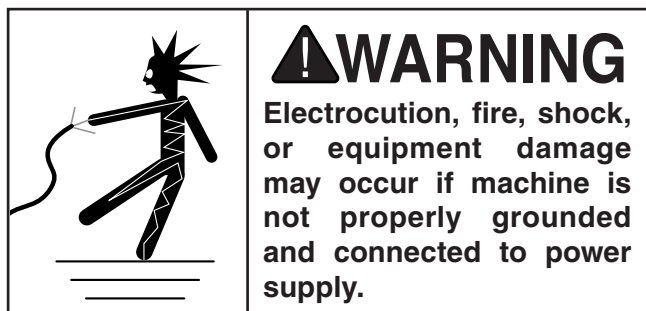

## Full-Load Current Rating

The full-load current rating is the amperage a machine draws at 100% of the rated output power. On machines with multiple motors, this is the amperage drawn by the largest motor or sum of all motors and electrical devices that might operate at one time during normal operations.

### G0796

**Full-Load Current Rating at 220V .. 19.5 Amps**

### G0797

**Full-Load Current Rating at 220V .... 6.4 Amps**

**Full-Load Current Rating at 440V .... 3.2 Amps**

The full-load current is not the maximum amount of amps that the machine will draw. If the machine is overloaded, it will draw additional amps beyond the full-load rating.

If the machine is overloaded for a sufficient length of time, damage, overheating, or fire may result—especially if connected to an undersized circuit. To reduce the risk of these hazards, avoid overloading the machine during operation and make sure it is connected to a power supply circuit that meets the specified circuit requirements.

## Circuit Information

A power supply circuit includes all electrical equipment between the breaker box or fuse panel in the building and the machine. The power supply circuit used for this machine must be sized to safely handle the full-load current drawn from the machine for an extended period of time. (If this machine is connected to a circuit protected by fuses, use a time delay fuse marked D.)

**Note:** *Circuit requirements in this manual apply to a dedicated circuit—where only one machine will be running on the circuit at a time. If machine will be connected to a shared circuit where multiple machines may be running at the same time, consult an electrician or qualified service personnel to ensure circuit is properly sized for safe operation.*

## ! CAUTION

**For your own safety and protection of property, consult an electrician if you are unsure about wiring practices or electrical codes in your area.**

## Grounding Requirements

This machine **MUST** be grounded. In the event of certain malfunctions or breakdowns, grounding reduces the risk of electric shock by providing a path of least resistance for electric current.

Improper connection of the equipment-grounding wire can result in a risk of electric shock. The wire with green insulation (with or without yellow stripes) is the equipment-grounding wire. If repair or replacement of the power cord or plug is necessary, do not connect the equipment-grounding wire to a live (current carrying) terminal.

Check with a qualified electrician or service personnel if you do not understand these grounding requirements, or if you are in doubt about whether the tool is properly grounded. If you ever notice that a cord or plug is damaged or worn, disconnect it from power, and immediately replace it with a new one.



# ⚠ CAUTION

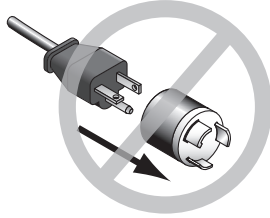

No adapter should be used with plug. If plug does not fit available receptacle, or if machine must be reconnected for use on a different type of circuit, reconnection must be performed by an electrician or qualified service personnel, and it must comply with all local codes and ordinances.

## G0796 Circuit Requirements

This machine is prewired to operate on a power supply circuit that has a verified ground and meets the following requirements:

**Nominal Voltage** .....208V, 220V, 230V, 240V  
**Cycle** .....60 Hz  
**Phase** ..... 1-Phase  
**Power Supply Circuit** ..... 30 Amps  
**Plug/Receptacle** .....NEMA L6-30  
**Cord** ..... “S”-Type, 3-Wire, 12 AWG, 300 VAC

The power cord and plug used on this machine must have an equipment-grounding wire and grounding prong. The plug must only be inserted into a matching receptacle (outlet) that is properly installed and grounded in accordance with all local codes and ordinances (see figure below).

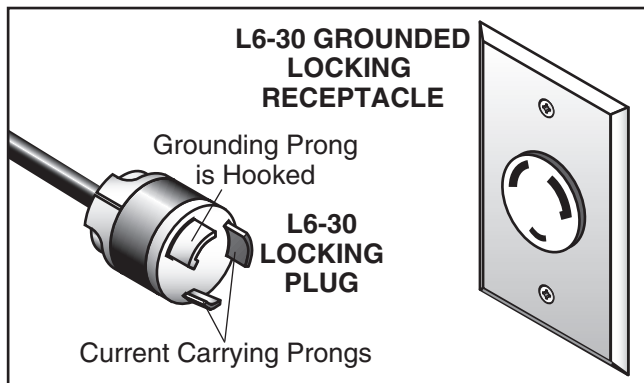

Figure 6. Typical L6-30 plug and receptacle.

## G0797 220V Circuit Requirements

This machine is prewired to operate on a power supply circuit that has a verified ground and meets the following requirements:

**Nominal Voltage** .....208V, 220V, 230V, 240V  
**Cycle** .....60 Hz  
**Phase** ..... 3-Phase  
**Power Supply Circuit** ..... 15 Amps  
**Plug/Receptacle** .....NEMA 15-15  
**Cord** ..... “S”-Type, 4-Wire, 14 AWG, 300 VAC

## Connection Type

The power cord and plug used on this machine must have an equipment-grounding wire and grounding prong. The plug must only be inserted into a matching receptacle (outlet) that is properly installed and grounded in accordance with all local codes and ordinances (see figure below).

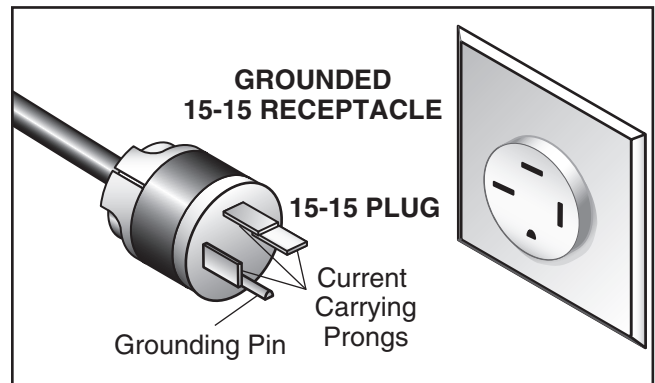

Figure 7. Typical 15-15 plug and receptacle.

## Extension Cords (220V Only)

We do not recommend using an extension cord with this machine. If you must use an extension cord, only use it if absolutely necessary and only on a temporary basis.

Extension cords cause voltage drop, which can damage electrical components and shorten motor life. Voltage drop increases as the extension cord size gets longer and the gauge size gets smaller (higher gauge numbers indicate smaller sizes).

Any extension cord used with this machine must be in good condition and contain a ground wire and matching plug/receptacle. Additionally, it must meet the following size requirements:

**Minimum Gauge Size (G0796)** .....12 AWG  
**Minimum Gauge Size (G0797 220V)**...14 AWG  
**Maximum Length (Shorter is Better)**.....50 ft.



## G0797 440V Circuit Requirements

This machine can be converted to operate on a power supply circuit that has a verified ground and meets the requirements listed below. (Refer to **Voltage Conversion** instructions for details.)

**Nominal Voltage** ..... 440V, 480V  
**Cycle** ..... 60 Hz  
**Phase** ..... 3-Phase  
**Power Supply Circuit** ..... 15 Amps

## Connection Type

A permanently connected (hardwired) power supply is typically installed with wires running through mounted and secured conduit. A disconnecting means, such as a locking switch (see following figure), must be provided to allow the machine to be disconnected (isolated) from the power supply when required. This installation must be performed by an electrician in accordance with all applicable electrical codes and ordinances.

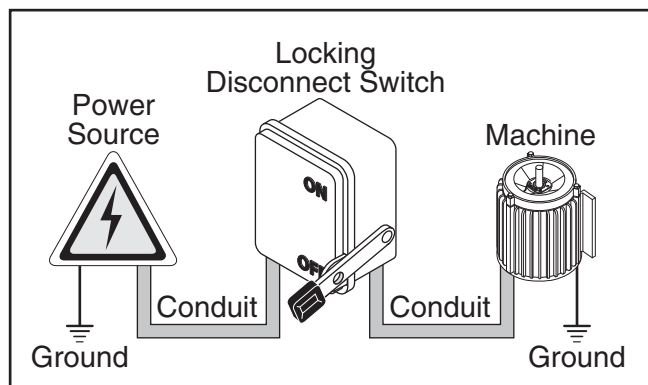

**Figure 8.** Typical setup of a permanently connected machine.

## Grounding Instructions

In the event of a malfunction or breakdown, grounding provides a path of least resistance for electrical current to reduce the risk of electric shock. A permanently connected machine must be connected to a grounded metal permanent wiring system; or to a system having an equipment-grounding conductor. All grounds must be verified and rated for the electrical requirements of the machine. Improper grounding can increase the risk of electric shock!

### **!WARNING**

**Serious injury could occur if you connect machine to power before completing setup process. DO NOT connect to power until instructed later in this manual.**

## Extension Cords

Since this machine must be permanently connected to the power supply, an extension cord cannot be used.

### **NOTICE**

**Avoid using static phase converter to supply 3-Phase power, as it could damage or decrease life of sensitive electrical components. If you must use a phase converter, only use a rotary phase converter that is sized at least 50% larger than largest HP rating of this machine.**



# Converting Voltage to 440V

The Model G0797 can be converted from 220V to 440V operation. This conversion consists of: 1) Disconnecting the machine from power, and 2) rewiring the motor junction box for 440V operation. Refer to **Page 70** of this update for a detailed 440V wiring diagram.

All wiring changes must be done by an electrician or qualified service personnel before the machine is connected to the power source. If, at any time during this procedure you need help, call Grizzly Tech Support at (570) 546-9663.

## To convert G0797 for 440V operation:

1. DISCONNECT MACHINE FROM POWER!
2. Remove cover from motor junction box (see **Figure 9**).

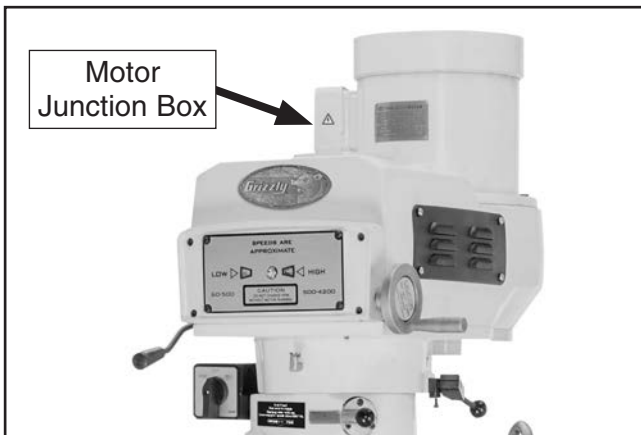

**Figure 9.** Location of motor junction box.

3. Rewire motor for 440V operation according to wiring diagram below (see **Figure 10**).

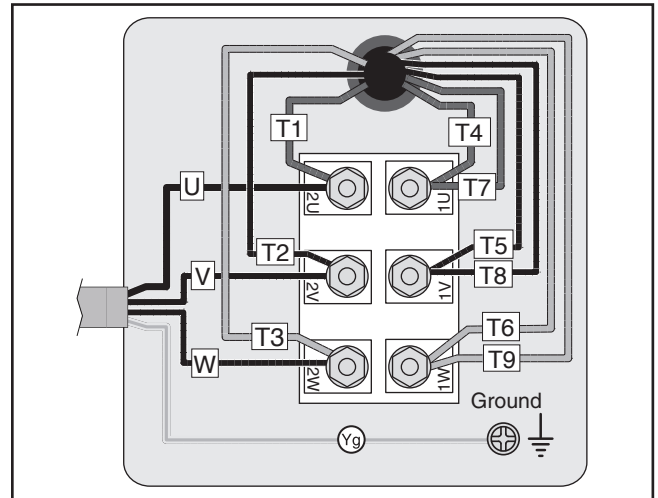
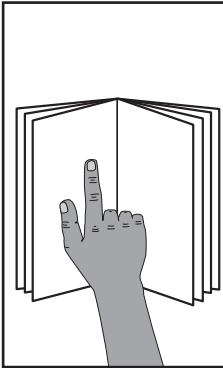

**Figure 10.** Motor junction box rewired for 440V.

4. Re-install motor junction box cover removed in **Step 2**.
5. Connect machine to power as instructed on **Page 28**.



# SECTION 3: SETUP



## **!WARNING**

This machine presents serious injury hazards to untrained users. Read through this entire manual to become familiar with the controls and operations before starting the machine!

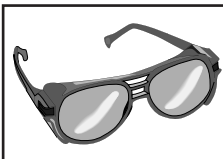

## **!WARNING**

Wear safety glasses during the entire setup process!



## **!WARNING**

### HEAVY LIFT!

Straining or crushing injury may occur from improperly lifting machine or some of its parts. To reduce this risk, get help from other people and use a forklift (or other lifting equipment) rated for weight of this machine.

## **!WARNING**

No list of safety guidelines can be complete. Every shop environment is different. Always consider safety first, as it applies to your individual working conditions. Use this and other machinery with caution and respect. Failure to do so could result in serious personal injury, damage to equipment, or poor work results.

## Needed for Setup

The following items are needed, but not included, for the setup/assembly of this machine.

Description	Qty
• Wrench or Socket 14mm.....	1
• Precision Level.....	1
• Safety Glasses (for each person).....	1
• Solvent/Cleaner.....	1
• Shop Rags.....	1
• Brass Hammer.....	1
• Lifting Straps (Rated min. 3000 lbs.).....	2
• Lifting Equipment (Rated min. 3000 lbs.)...	1
• Additional People.....	2

## Unpacking

This machine was carefully packaged for safe transport. When unpacking, separate all enclosed items from packaging materials and inspect them for shipping damage. ***If items are damaged, please call us immediately at (570) 546-9663.***

**IMPORTANT:** Save all packaging materials until you are completely satisfied with the machine and have resolved any issues between Grizzly or the shipping agent. ***You MUST have the original packaging to file a freight claim. It is also extremely helpful if you need to return your machine later.***



# Inventory

The following is a list of items shipped with your machine. Before beginning setup, lay these items out and inventory them.

If any non-proprietary parts are missing (e.g. a nut or a washer), we will gladly replace them; or for the sake of expediency, replacements can be obtained at your local hardware store.

## NOTICE

If you cannot find an item on this list, carefully check around/inside the machine and packaging materials. Often, these items get lost in packaging materials while unpacking or they are pre-installed at the factory.

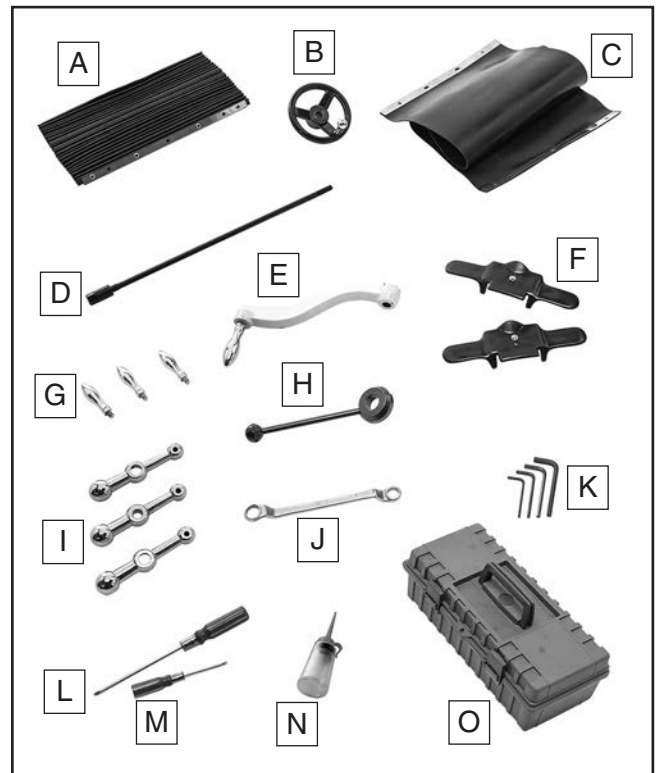

Figure 11. Small item inventory.

Small Item Inventory (Figure 11)	Qty
A. Front Way Cover.....	1
B. Fine Downfeed Handwheel .....	1
C. Rear Way Cover .....	1
D. Drawbar .....	1
E. Knee Crank .....	1
F. Belt Housing Safety Covers (G0796) .....	2
G. Revolving Handles .....	3
H. Coarse Downfeed Lever.....	1
I. Ball Handles .....	3
J. Closed-End Wrench 17/19mm.....	1
K. Hex Wrench Set 4, 5, 6, 8MM.....	1 Ea
L. Phillips Screwdriver #2 .....	1
M. Slotted Screwdriver #2 .....	1
N. Bottle for Oil .....	1
O. Toolbox.....	1



# Cleanup

The unpainted surfaces of your machine are coated with a heavy-duty rust preventative that prevents corrosion during shipment and storage. This rust preventative works extremely well, but it will take a little time to clean.

Be patient and do a thorough job cleaning your machine. The time you spend doing this now will give you a better appreciation for the proper care of your machine's unpainted surfaces.

There are many ways to remove this rust preventative, but the following steps work well in a wide variety of situations. Always follow the manufacturer's instructions with any cleaning product you use and make sure you work in a well-ventilated area to minimize exposure to toxic fumes.

## Before cleaning, gather the following:

- Disposable rags
- Cleaner/degreaser (WD•40 works well)
- Safety glasses & disposable gloves
- Plastic paint scraper (optional)

## Basic steps for removing rust preventative:

1. Put on safety glasses.
2. Coat the rust preventative with a liberal amount of cleaner/degreaser, then let it soak for 5–10 minutes.
3. Wipe off the surfaces. If your cleaner/degreaser is effective, the rust preventative will wipe off easily. If you have a plastic paint scraper, scrape off as much as you can first, then wipe off the rest with the rag.
4. Repeat **Steps 2–3** as necessary until clean, then coat all unpainted surfaces with a quality metal protectant to prevent rust.

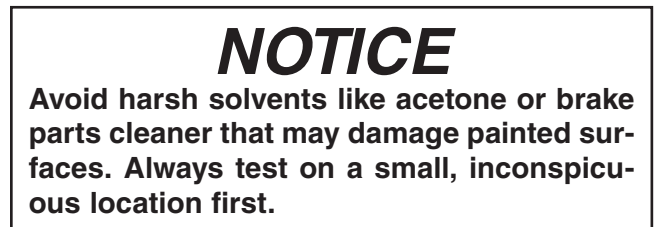
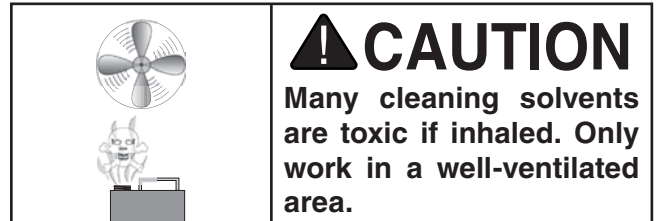
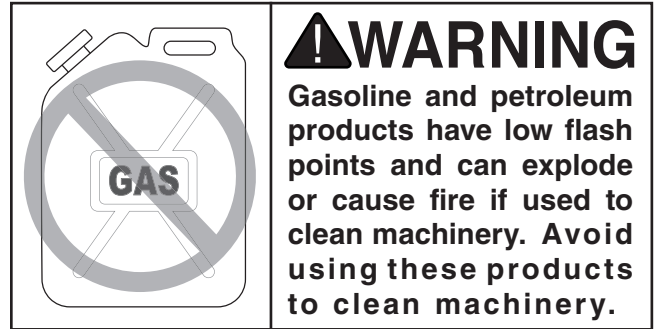

## T23692—Orange Power Degreaser

A great product for removing the waxy shipping grease from the **non-painted** parts of the machine during clean up.



Figure 12. T23692 Orange Power Degreaser.





# Site Considerations

## Weight Load

Refer to the **Machine Data Sheet** for the weight of your machine. Make sure that the surface upon which the machine is placed will bear the weight of the machine, additional equipment that may be installed on the machine, and the heaviest workpiece that will be used. Additionally, consider the weight of the operator and any dynamic loading that may occur when operating the machine.

## Space Allocation

Consider the largest size of workpiece that will be processed through this machine and provide enough space around the machine for adequate operator material handling or the installation of auxiliary equipment. With permanent installations, leave enough space around the machine to open or remove doors/covers as required by the maintenance and service described in this manual. **See below for required space allocation.**

## Physical Environment

The physical environment where the machine is operated is important for safe operation and longevity of machine components. For best results, operate this machine in a dry environment that is free from excessive moisture, hazardous chemicals, airborne abrasives, or extreme conditions. Extreme conditions for this type of machinery are generally those where the ambient temperature range exceeds 41°–104°F; the relative humidity range exceeds 20%–95% (non-condensing); or the environment is subject to vibration, shocks, or bumps.

## Electrical Installation

Place this machine near an existing power source. Make sure all power cords are protected from traffic, material handling, moisture, chemicals, or other hazards. Make sure to leave enough space around machine to disconnect power supply or apply a lockout/tagout device, if required.

## Lighting

Lighting around the machine must be adequate enough that operations can be performed safely. Shadows, glare, or strobe effects that may distract or impede the operator must be eliminated.

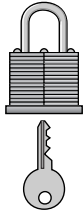

**CAUTION**

Children or untrained people may be seriously injured by this machine. Only install in an access restricted location.

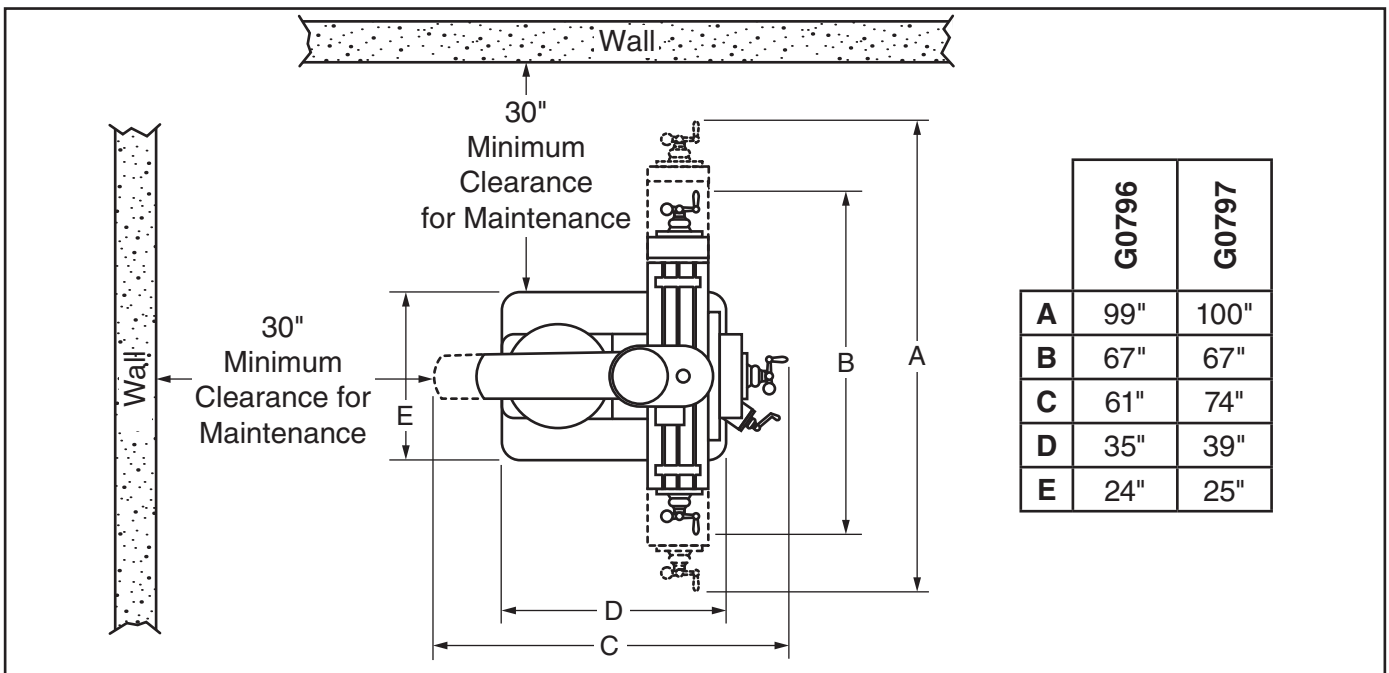

**Figure 13.** Minimum working clearances.



# Lifting & Placing

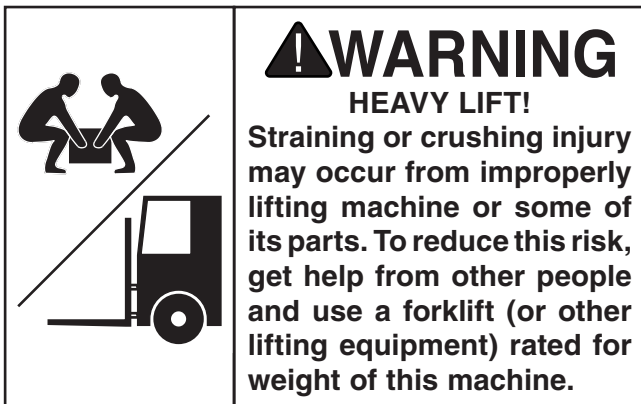

Use a forklift and at least two other people (see **Page 20**) to lift the machine off the pallet and onto a suitable location.

## To lift and move mill:

1. Remove crate from shipping pallet, then with mill still on pallet, move to installation location.
2. Rotate ram 180° so headstock is facing backwards (see **Figure 14**), then rotate head upright.

Refer to **Positioning Headstock** on **Page 35** and **Positioning Ram** on **Page 36** for detailed instructions to help with this step.

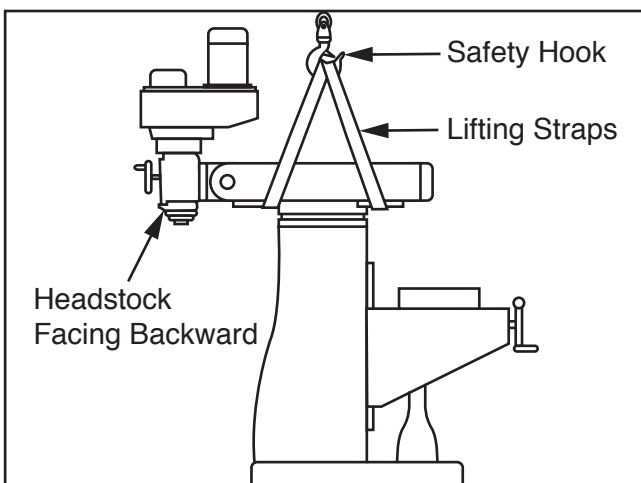

**Figure 14.** Illustrated example of using lifting straps to move the mill.

**Note:** After re-positioning ram and headstock, make sure they are locked in place to prevent unexpected movement during lifting.

Make sure the four turret lock bolts (two on each side of the ram, see **Figure 15**) are torqued to 47 ft./lbs. to keep the ram from unexpectedly moving from the force of the lifting straps.

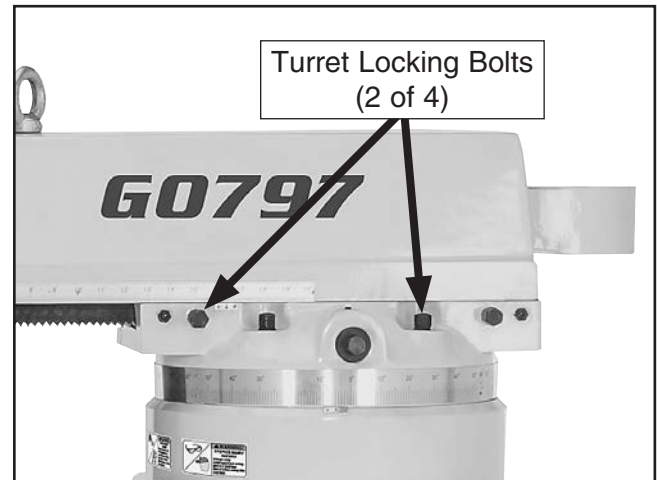

**Figure 15.** Locations of turret locking bolts.

3. Place lifting straps under ram and connect them to safety hook, as illustrated in **Figure 14**.

**Note:** Place protective material between straps and mill to protect ram and ways, and to keep from cutting lifting straps.

4. Unbolt mill from shipping pallet.
5. With other people steadying load to keep it from swaying, lift mill a couple of inches.
  - If mill tips to one side, lower it to the ground and adjust ram or table to balance the load. Make sure to re-tighten lock levers and bolts before lifting mill again.
  - If mill lifts evenly, remove shipping pallet and lower mill onto its prepared location.



# Leveling

Leveling machinery helps precision components, such as dovetail ways, remain straight and flat during the lifespan of the machine. Components on an unlevelled machine may slowly twist due to the dynamic loads placed on the machine during operation.

Use metal shims between the base and the floor when leveling the machine.

For best results, use a precision level that is at least 12" long and sensitive enough to show a distance movement when a 0.003" shim (approximately the thickness of one sheet of standard newspaper) is placed under one end of the level.

See **Figure 16** for an example of a high precision level provided by Grizzly.



**Figure 16.** Model H2683 12" Master Machinist's Level.

# Anchoring to Floor

**Number of Mounting Holes** ..... 4  
**Diameter of Mounting Holes** ..... 5/8"

Anchoring machinery to the floor prevents tipping or shifting and reduces vibration that may occur during operation, resulting in a machine that runs slightly quieter and feels more solid.

If the machine will be installed in a commercial or workplace setting, or if it is permanently connected (hardwired) to the power supply, local codes may require that it be anchored to the floor.

If not required by any local codes, fastening the machine to the floor is an optional step. If you choose not to do this with your machine, we recommend placing it on machine mounts, as these provide an easy method for leveling and they have vibration-absorbing pads.

## Anchoring to Concrete Floors

Lag shield anchors with lag screws (see below) are a popular way to anchor machinery to a concrete floor, because the anchors sit flush with the floor surface, making it easy to unbolt and move the machine later, if needed. However, anytime local codes apply, you **MUST** follow the anchoring methodology specified by the code.

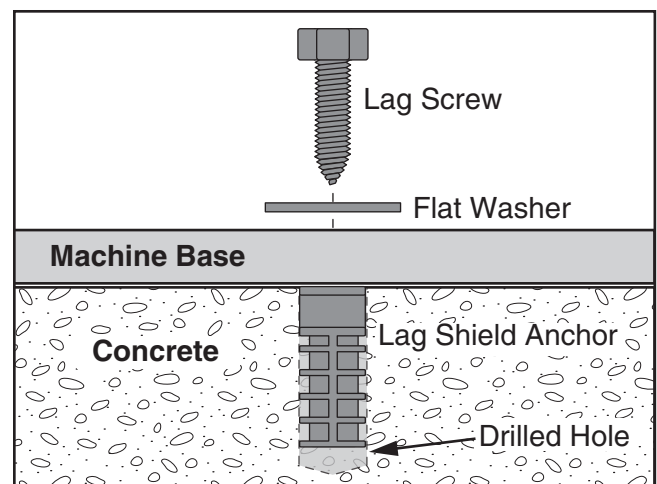

**Figure 17.** Popular method for anchoring machinery to a concrete floor.



# Assembly

The machine must be fully assembled before it can be operated. Before beginning the assembly process, refer to **Needed for Setup** and gather all listed items. To ensure the assembly process goes smoothly, first clean any parts that are covered or coated in heavy-duty rust preventative (if applicable).

Assembly of the mill consists of installing the loose components listed in the inventory section. This will take approximately 15 minutes.

## To assemble mill:

1. Remove ball handle nuts from X- and Y-axis leadscrews, slide ball handles onto leadscrews, and secure with ball handle nuts (see **Figure 18**).

**Note:** *Tighten the ball handle nuts just until they are snug. Overtightening could increase the wear of the moving parts.*

2. Thread revolving handles into small end of ball handles (see **Figure 18**) and tighten them with 14mm wrench.

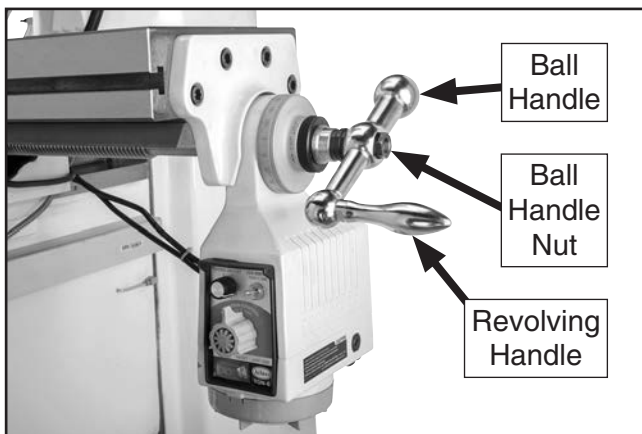

**Figure 18.** Ball handle installed on X-axis leadscrew.

3. Slide Z-axis crank onto end of Z-axis leadscrew, as shown in **Figure 19**.

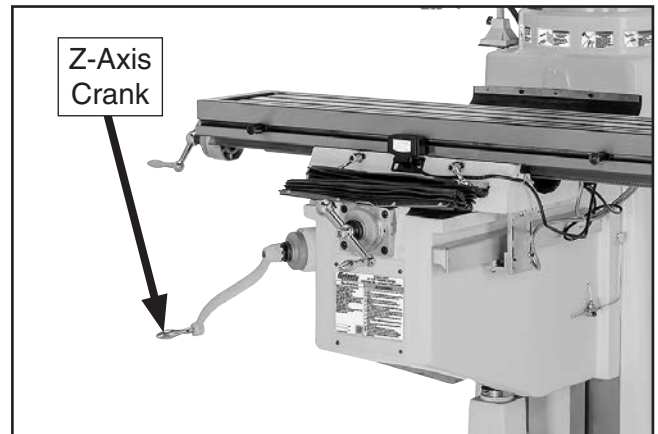

**Figure 19.** Z-axis crank installed.

4. Move table all the way forward, using Y-axis handwheel, then attach rear way cover with four pre-installed cap screws, as shown in **Figure 20**.

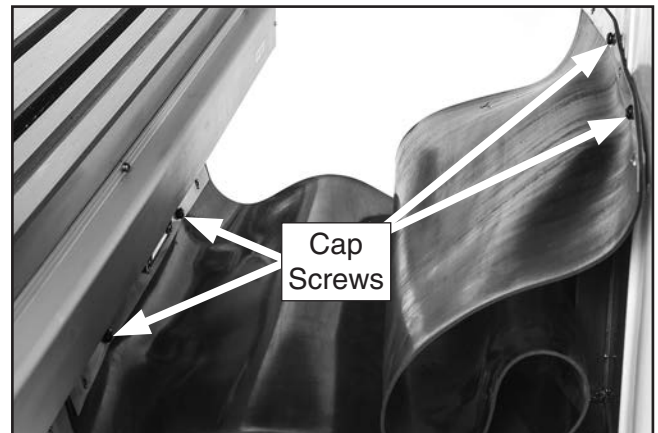

**Figure 20.** Rear way cover installed.



5. Move table all the way back toward the column, then attach front way cover with five pre-installed cap screws, as shown in **Figure 21**.

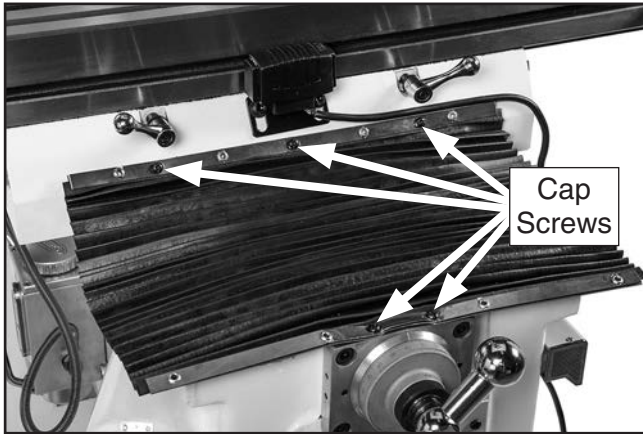

**Figure 21.** Front way cover installed.

6. Install coarse downfeed lever (see **Figure 22**), making sure pin on back of lever seats in hub, then use a 4mm hex wrench to tighten set screw.
7. Use a Phillips head screwdriver to remove auto-downfeed direction pin from hub, then mount fine downfeed handwheel on hub, making sure pin on back of handwheel seats in hub, and secure with auto-downfeed direction pin (see **Figure 22**).

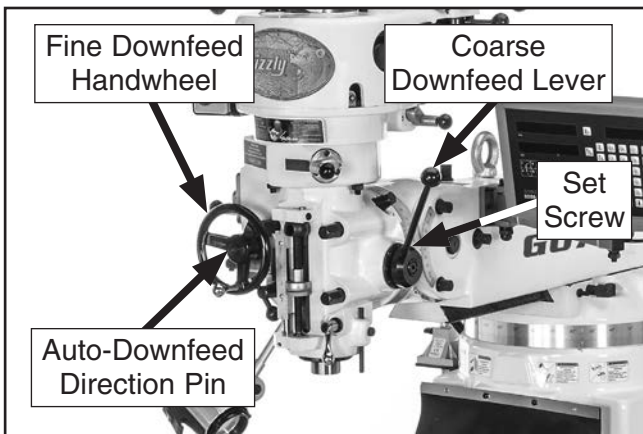

**Figure 22.** Downfeed controls installed.

## Power Connection (G0796)

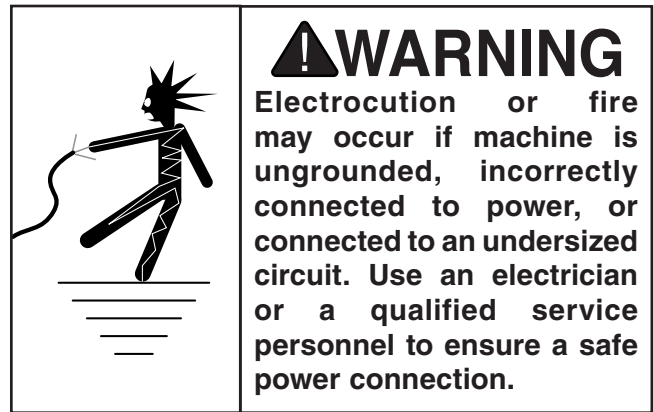

Before the machine can be connected to the power source, an electrical circuit and connection device must be prepared per the **POWER SUPPLY** section in this manual, and all previous setup instructions in this manual must be complete to ensure that the machine has been assembled and installed properly.

Always make sure the power switch on the machine is turned to the OFF position before connecting power.

### Power Connection

Insert power cord plug into a matching power supply receptacle. The machine is now connected to the power source.

If you need to disconnect the machine from power later, pull the plug completely out of the receptacle.

**Note About Extension Cords:** *Using an incorrectly sized extension cord may decrease the life of electrical components on your machine. Refer to **Extension Cords** on **Page 17** for more information.*



# Power Connection (G0797 220V)

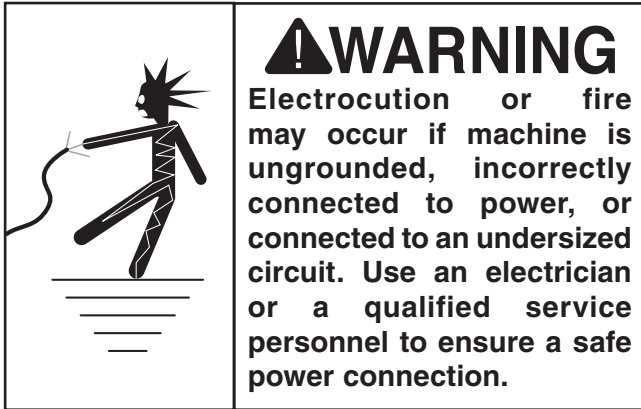

Before the machine can be connected to the power source, an electrical circuit and connection device must be prepared per the **POWER SUPPLY** section in this manual, and all previous setup instructions in this manual must be complete to ensure that the machine has been assembled and installed properly.

Always make sure the power switch on the machine is turned to the OFF position before connecting power.

## Power Connection

Insert power cord plug into a matching power supply receptacle. The machine is now connected to the power source.

If you need to disconnect the machine from power later, pull the plug completely out of the receptacle.

**Note About Extension Cords:** Using an incorrectly sized extension cord may decrease the life of electrical components on your machine. Refer to **Extension Cords** on **Page 17** for more information.

# Power Connection (G0797 440V)

Before the machine can be connected to the power source, an electrical circuit and connection device must be prepared per the **POWER SUPPLY** section in this manual; and all previous setup instructions in this manual must be complete to ensure that the machine has been assembled and installed properly. The disconnect switch installed by the electrician (as recommended) is the primary means for disconnecting or connecting the machine to the power source.

## Connecting to Power Source

Move the disconnect switch handle to the ON position, as illustrated below. The machine is now connected to the power source.

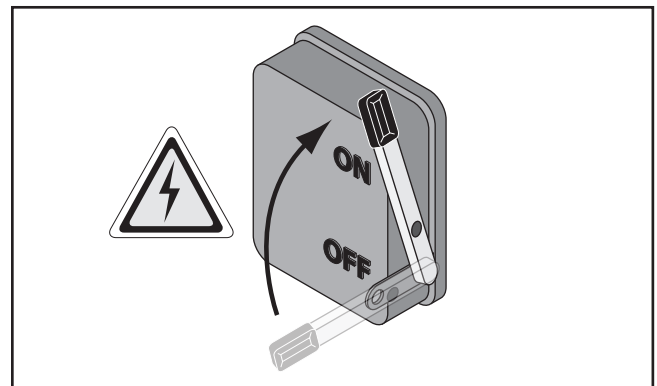
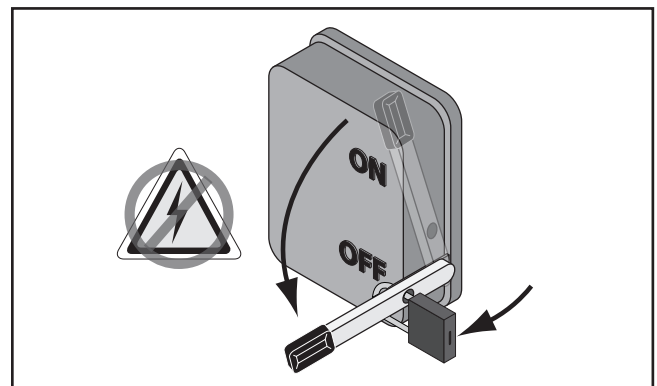

**Figure 23.** Connecting power to machine.

## Disconnecting from Power Source

Move the disconnect switch handle to the OFF position, as illustrated below. The machine is now disconnected from the power source.

**Note:** Lock the switch in the OFF position to restrict others from starting the machine.



**Figure 24.** Disconnecting power from machine.



# Test Run

Once assembly is complete, test run your machine to make sure it runs properly and is ready for regular operation.

The test run consists of verifying the following:  
1) The motor powers up and runs correctly,  
2) the spindle switch works correctly, and 3) (G0797 only) the motor turns the correct direction (machine is not wired out of phase).

If, during the test run, you cannot easily locate the source of an unusual noise or vibration, stop using the machine immediately, then review **Troubleshooting** on **Page 54**.

If you still cannot remedy a problem, contact our Tech Support at (570) 546-9663 for assistance.

## **⚠️ WARNING**

**DO NOT start machine until all preceding setup instructions have been performed. Operating an improperly set up machine may result in malfunction or unexpected results that can lead to serious injury, death, or machine/property damage.**

### Mill Test Run

1. Make sure you understand all safety instructions at beginning of manual and that machine is set up properly.
2. Make sure all tools and objects used during setup are cleared away from machine.
3. Make sure that mill is properly lubricated (refer to **Lubrication** section on **Page 50** for specific details).
4. Set spindle speed to low range (refer to **Spindle Speed**, beginning on **Page 37** for detailed instructions).
5. Move downfeed selector to manual (forward) position so that spindle does not automatically downfeed during this test (refer to **Downfeed Controls** section on **Page 40** for detailed instructions).

6. Rotate spindle switch to STOP (G0796) or OFF (G0797) to avoid accidental startup in **Step 7**.
7. Connect mill to power source specified in **POWER SUPPLY** section on **Page 17**.
8. Rotate spindle switch to FOR (forward) position (see **Figure 25** or **26**).

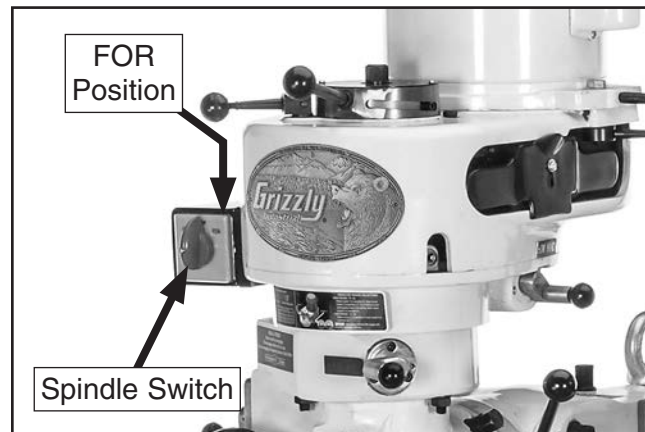

**Figure 25.** Model G0796 spindle switch.

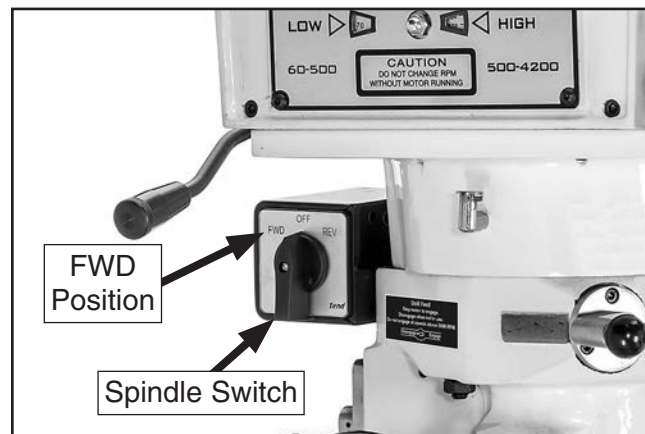

**Figure 26.** Model G0797 spindle switch.

9. Listen for abnormal noises and watch for unexpected actions from mill. Machine should run smoothly and without excessive vibration or rubbing noises.  
— Strange or unusual noises or actions must be investigated immediately. Turn the machine **OFF** and disconnect it from the power source before investigating or correcting potential problems.
10. Rotate spindle switch to STOP (G0796) or OFF (G0797) to stop spindle rotation.



## Power Feed Test Run

This mill comes with a power feed unit for X-axis table travel. Proper operation of the limit switch attached to the front middle of the table is important to the operation of this power feed unit. If the power feed does not operate as expected during the following steps, disconnect it from power and contact our Tech Support at (570) 546-9663 for assistance.

### **CAUTION**

**During power feed operation, ball handles spin rapidly when engaged. Always stay clear of ball handles when using power feed. Failure to do so could lead to entanglement or impact injuries.**

#### To test run power feed:

1. Make sure all tools, cables, and other items are well clear of table movement and potential direction of travel.
2. Refer to **Operating X-Axis Power Feed** section, beginning on **Page 34**, to understand how power feed, table locks, and limit switch function.
3. Loosen table locks on front of table.
4. Plug power feed power cord into a grounded 110V power outlet.
5. Make sure power feed direction knob is in neutral (middle) position, turn speed dial counterclockwise to lowest setting, then press ON button.
6. Turn direction knob to left, slowly turn speed dial clockwise to increase speed, then confirm that table is moving to left.
7. Watch for table limit stop to hit limit switch and turn power feed **OFF**, stopping table movement.
8. Turn direction knob through neutral (middle) position and all the way to the right. Table should begin moving to the right.
9. Confirm that table stops moving when limit stop presses against limit switch plunger.
10. Move direction knob to neutral (middle) position, turn speed dial to lowest setting, and press OFF button.

Congratulations! The **Test Run** of the mill is complete. Continue to the next page to perform the **Spindle Break-In** and **Inspections & Adjustments** procedures.





# Spindle Break-In

## NOTICE

**You must complete this procedure to maintain the warranty. Failure to do this could cause rapid wear-and-tear of spindle bearings once they are placed under load.**

The spindle break-in procedure distributes lubrication throughout the bearings to reduce the risk of early bearing failure if there are any "dry" spots or areas where lubrication has settled in the bearings. You **must** complete this procedure **before** placing operational loads on the spindle for the first time when the machine is new or if it has been sitting idle for longer than 6 months.

Always start the spindle break-in at the lowest speed to minimize wear if there *are* dry spots. Allow the spindle to run long enough to warm up and distribute the bearing grease, then incrementally increase spindle speeds and repeat this process at each speed until reaching the maximum spindle speed. Following the break-in procedure in this progressive manner helps minimize any potential wear that could occur before lubrication is fully distributed.

### To perform spindle break-in procedure:

1. Successfully perform all steps in **Test Run** section beginning on **Page 29**.
2. Set spindle speed to low range (refer to **Spindle Speed**, beginning on **Page 37** for detailed instructions).  
  
**Note:** *When operating in low range, spindle will rotate in reverse when spindle switch is set to FOR or FWD, and spindle will rotate in forward when switch is set to reverse.*
3. Run spindle in forward rotation at following speed for 5 minutes, turn spindle **OFF** and allow it to come to a complete stop, then repeat in reverse rotation.

**G0796:** 80 RPM  
**G0797:** 60 RPM

4. Repeat **Step 3** for following speeds, progressing from lower to higher RPMs:

**G0796:** 210, 325 RPM  
**G0797:** 250, 400 RPM

5. Set spindle speed to high range, and repeat **Step 3** for following speeds, progressing from lower to higher RPMs:

**G0796:** 660, 1715, 2720 RPM  
**G0797:** 500, 2500, 4000 RPM

**Note:** *Make sure to turn spindle **OFF** and allow it to come to a complete stop before switching direction and before changing speed.*

Congratulations, the spindle break-in is now complete!

## NOTICE

**Since the mill head has been moved around for shipping purposes, you will need to tram the spindle with the table to ensure a 90° alignment. Refer to the *Tramming Spindle* section on *Page 60* for detailed instructions.**

# Inspections & Adjustments

The following list of adjustments were performed at the factory before the machine was shipped:

- Gib Adjustments ..... **Page 57**
- Leadscrew Backlash Adjustments..... **Page 58**

Be aware that machine components can shift during the shipping process. Pay careful attention to these adjustments during operation of the machine. If you find that the adjustments are not set according to the procedures in this manual or your personal preferences, re-adjust them.



# SECTION 4: OPERATIONS

## Operation Overview

The purpose of this overview is to provide the novice machine operator with a basic understanding of how the machine is used during operation, so the machine controls/components discussed later in this manual are easier to understand.

Due to the generic nature of this overview, it is **not** intended to be an instructional guide. To learn more about specific operations, read this entire manual, seek additional training from experienced machine operators, and do additional research outside of this manual by reading "how-to" books, trade magazines, or websites.

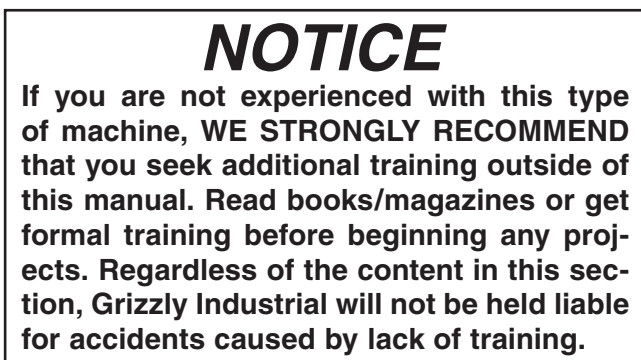

To complete a typical operation, the operator does the following:

1. Examines workpiece to make sure it is suitable for milling.
2. Positions table according to operation and size of workpiece.
3. Firmly clamps workpiece to table or a mill vise.
4. Installs correct cutting tool for operation.
5. Uses manual downfeed and table controls to correctly position cutting tool and workpiece for operation. If X-axis power feed will be used during operation, operator confirms speed and length of table movement required.
6. Configures mill for correct spindle speed of operation.
7. Puts on required safety glasses and face shield, and makes sure workpiece and table are clear of all tools, cords, and other items.
8. Turns mill **ON** by starting spindle rotation, then performs operation.
9. Turns mill **OFF**.



# Positioning Table

The mill table moves in three directions, as illustrated in **Figure 27**:

- X-axis (longitudinal)
- Y-axis (cross)
- Z-axis (vertical)

These movements are controlled by rotating the X- and Y-axis ball handles and the Z-axis crank. Additionally, the table can be moved along the X-axis with the power feed.

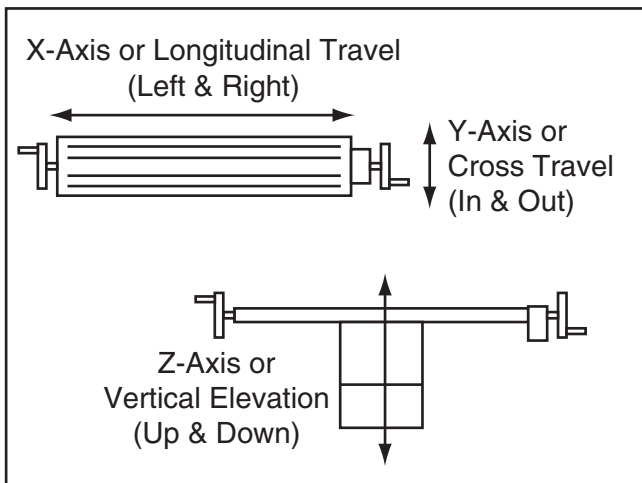
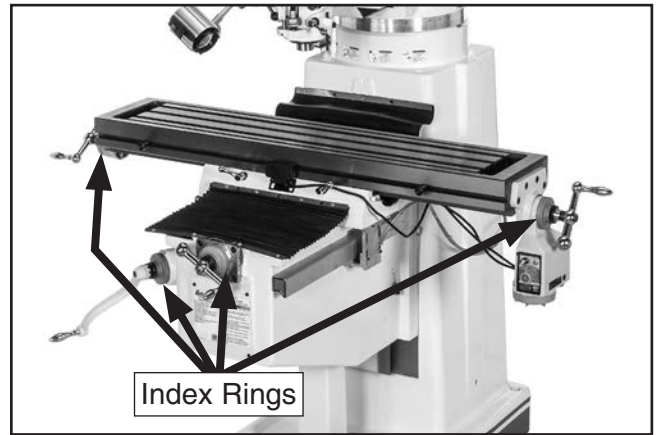

**Figure 27.** The directions of table movement.

## Graduated Index Rings

The table ball handles and knee crank have graduated index rings (see **Figure 28**) that are used to determine table movement in the increments listed below:

Axis	Individual Increment	One Full Revolution
X	0.001"	0.200"
Y	0.001"	0.200"
Z	0.001"	0.100"

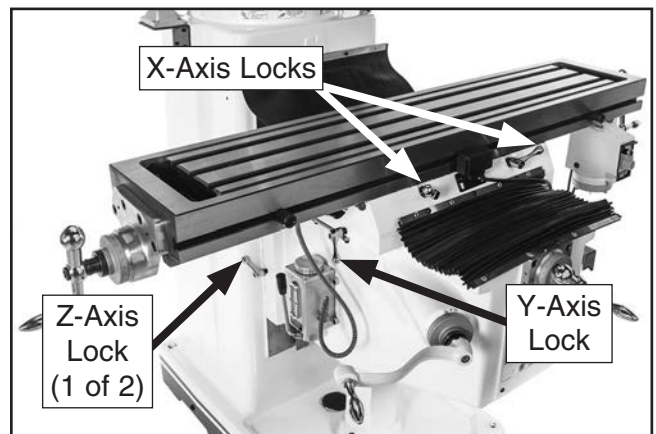

**Figure 28.** Locations of index rings.

## Table Locks

Use table locks to increase the rigidity of the table when movement in that direction is not required for the operation.

Refer to **Figure 29** to identify the locks for each table axis.



**Figure 29.** Locations of table locks for each axis.

## NOTICE

Always keep table locked in place unless table movement is required for your operation. Unexpected table and workpiece movement could cause cutter to bind with workpiece, which may ruin cutter or workpiece.



## Table Limit Stops

Two adjustable table limit stops are located at each end of the table (see **Figure 30**). They limit automatic table movement by pressing the table limit switch, which stops the X-axis power feed unit.

To adjust the position of the limit stops, loosen the cap screws securing the stops, reposition, and tighten securely. If not being used, position stops at far ends of table so as not to interfere with table movement.

## Operating X-Axis Power Feed

Tool Needed	Qty
Hex Wrench 8mm.....	1

### To operate X-axis power feed:

1. Loosen X-axis locks.
2. Turn speed dial (see **Figure 30**) all the way counterclockwise to slowest setting.
3. Move direction knob to neutral (middle) position, press feed/jog switch to left (feed position), then push ON/OFF button (see **Figure 30**).

4. With your hand poised over ON/OFF button in case you need to suddenly turn unit **OFF**, move direction knob to select desired direction of table travel.
5. Use speed dial to slowly bring speed of movement up to desired rate.

To jog table, move Feed/Jog switch (see **Figure 30**) to right (Jog) position. Table will move in selected direction until switch is released.

To cause table to instantly move at full speed when already in motion, press the rapid traverse button (see **Figure 30**). The table will resume previous speed when button is released.

6. When you are finished using power feed:
  - a. Turn unit **OFF**.
  - b. Rotate speed dial all the way counterclockwise.
  - c. Move direction knob to neutral (middle) position to avoid unexpected table movement later.

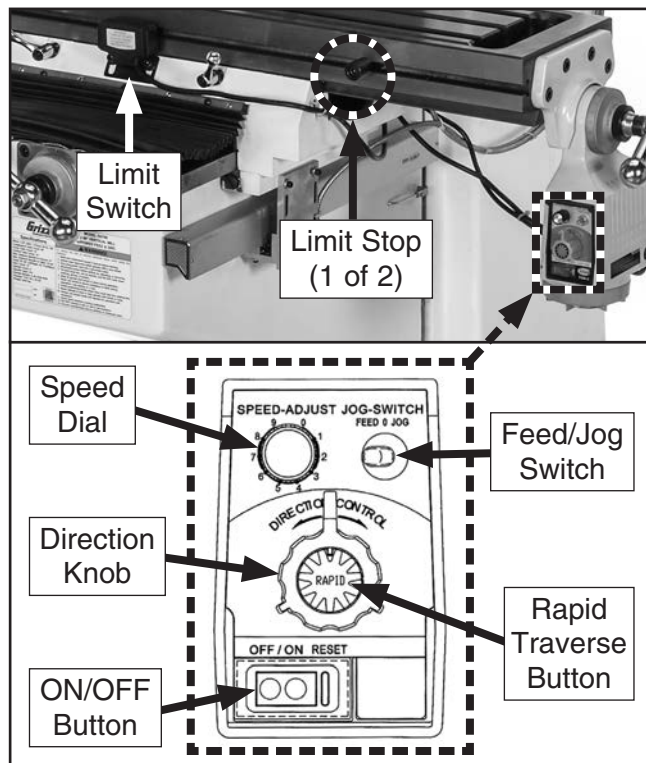

**Figure 30.** Location of X-axis power feed controls.

For additional component details, refer to **X-Axis Power Feed Identification** on **Page 8**.



# Positioning Headstock

The head tilts 45° forward or backward and rotates 90° left or right (see **Figures 31–32**).

Any time the head has been tilted or rotated, you must tram the spindle with the table when setting the headstock back to the 90° position. This is the only way to ensure precision milling results later. Refer to **Tramming Spindle** on **Page 60** for more information.

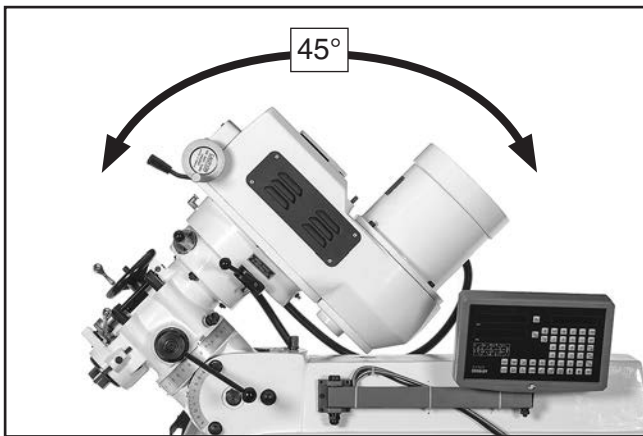

**Figure 31.** Head tilted 45° backward.

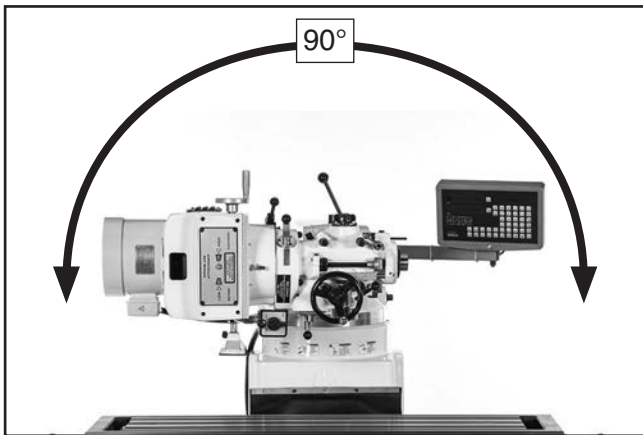

**Figure 32.** Head rotated to the left.

## **⚠ CAUTION**

The head is heavy. When tilting or rotating head, get help to support its weight as you make adjustments.

### Tools Needed

Qty

Wrench 19mm .....	1
Wrench 17mm (G0796).....	1

### Tilting Head Forward/Backward

1. DISCONNECT MACHINE FROM POWER!
2. Loosen three lock bolts shown in **Figure 33**.
3. Use one hand to apply pressure to head in direction of tilt, then slowly rotate tilt-bolt shown in **Figure 33**.

**Note:** Rotate tilt-bolt clockwise to tilt head backward and counterclockwise to tilt it forward.

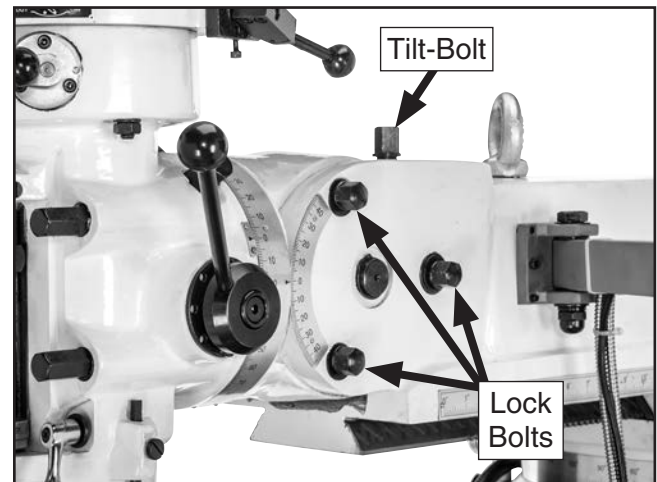

**Figure 33.** Head tilt controls.

4. Re-tighten lock bolts.



## Rotating Head Left/Right

1. DISCONNECT MACHINE FROM POWER!
2. Loosen four lock bolts shown in **Figure 34**.
3. Use one hand to apply pressure to head in direction of rotation, then slowly turn rotation bolt shown in **Figure 34**.

**Note:** Turn rotation bolt clockwise to rotate head left and counterclockwise to rotate it right.

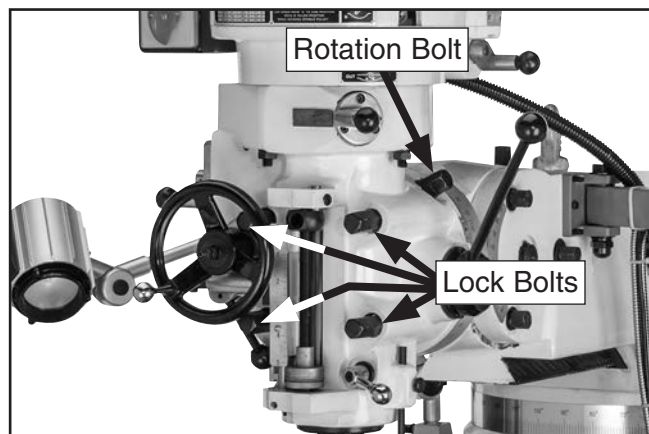

**Figure 34.** Head rotation controls.

**Note:** The lock bolts shown in **Figure 34** are threaded into T-nuts that travel in a circular slot during head rotation. When rotating head, it is possible for these T-nuts to jam in the slot preventing movement of head. If this happens, gently rotate each lock bolt, starting with the lower right, until you free up the jammed T-nut. Then continue to rotate head to desired position.

4. Re-tighten lock bolts.

## **NOTICE**

Always lock head firmly in place after tilting or rotating it. Unexpected movement of head during operations could cause damage to cutter or workpiece.

## Positioning Ram

The ram rotates 360° around the turret, and travels forward or backward 12" (G0796), or 18½" (G0797).

Tool Needed	Qty
Wrench 19mm .....	1

### Rotating Ram

1. DISCONNECT MACHINE FROM POWER!
2. Loosen four lock bolts on top of turret (see **Figure 35**).

**Note:** There are two lock bolts on each side of the ram.

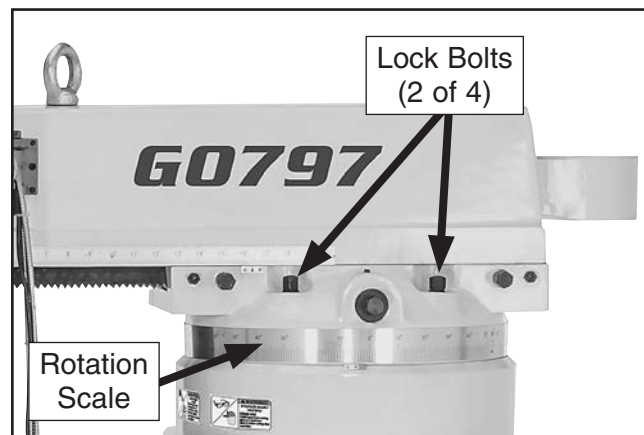

**Figure 35.** Ram rotational controls.

**Note:** In the next step, take care not to entangle or stretch electrical cabling as you move ram around turret.

3. Push head to manually rotate ram. Use rotation scale to determine correct position for your operation, then re-tighten four lock bolts to secure ram in place.



## Moving Ram Forward/Backward

1. DISCONNECT MACHINE FROM POWER!
2. Loosen two lock bolts shown in **Figure 36**.

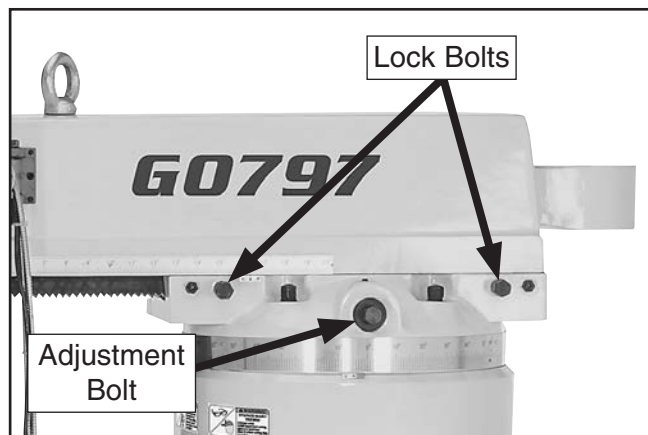

**Figure 36.** Ram forward/backward movement controls.

3. Make sure there are no obstructions to ram travel, especially any tooling around workpiece, then slowly rotate adjustment bolt to move ram.

**Note:** Rotate bolt clockwise to move ram away from table and counterclockwise to move ram toward table.

4. Re-tighten lock bolts.

### **NOTICE**

**Always lock ram firmly in place after moving it. Unexpected movement of ram and head during operations could damage cutter or workpiece.**

## Spindle Speed

Using the correct spindle speed is important for safe and satisfactory results, as well as maximizing tool life.

To set the spindle speed for your operation, you will need to: 1) Determine the best spindle speed for the cutting task, and 2) configure the spindle controls to match the closest spindle speed.

### Determining Spindle Speed

Many variables affect the optimum spindle speed to use for any given operation, but the two most important are the recommended cutting speed for the workpiece material and the diameter of the cutting tool, as noted below.

$$\frac{\text{*Recommended Cutting Speed (FPM) x 12}}{\text{Tool Dia. (in inches) x 3.14}} = \text{Spindle Speed (RPM)}$$

\*Double if using carbide cutting tool

**Figure 37.** Spindle speed formula for milling.

Cutting speed, typically defined in feet per minute (FPM), is the speed at which the edge of a tool moves across the material surface.

The "Recommended Cutting Speed" varies depending on the type of workpiece material. It is the ideal speed for cutting that material in order to optimize tool life and produce a desirable finish.

The books **Machinery's Handbook** or **Machine Shop Practice**, and some internet sites, provide excellent recommendations for which cutting speeds to use when calculating the spindle speed. These sources also provide a wealth of additional information about the variables that affect cutting speed and they are a good educational resource.

Also, there are a large number of easy-to-use spindle speed calculators that can be found on the internet. These sources will help you take into account all applicable variables to determine the best spindle speed for the operation.



## Setting G0796 Spindle Speed

The Model G0796 has eight spindle speeds—four in low motor speed and four in high motor speed. Setting the spindle speed involves: 1) Selecting the spindle speed range, 2) positioning the V-belt, and 3) setting the spindle switch.

### To set Model G0796 spindle speed:

1. DISCONNECT MACHINE FROM POWER!
2. Use chart below or spindle speed chart on headstock to find appropriate spindle speed for your operation (see **Figure 38**).
3. Pull spindle speed range selector knob (see **Figure 38**) out, position in HIGH or LOW range, then release knob to seat knob pin in detent.

**Note:** If it is difficult to move range selector knob, rotate spindle by hand to help mesh gears until selector moves freely.

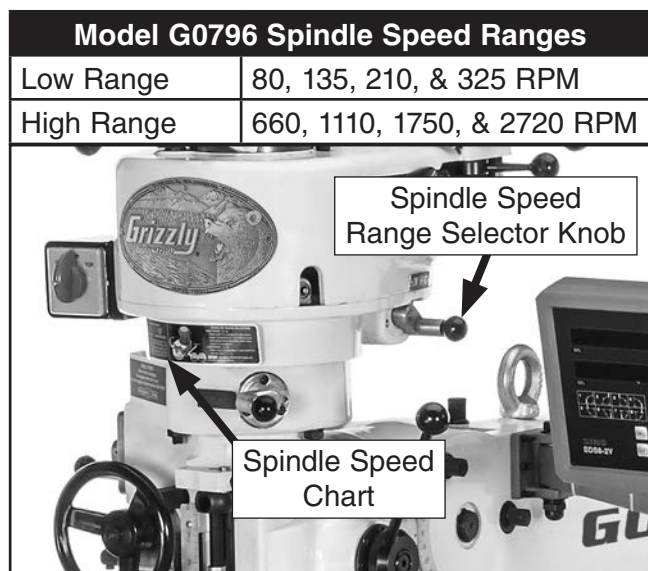

**Figure 38.** Model G0796 available spindle speeds, location of spindle speed chart, and range selector knob in the HIGH position.

4. Move range lever shown in **Figure 39** to HIGH or LOW position.

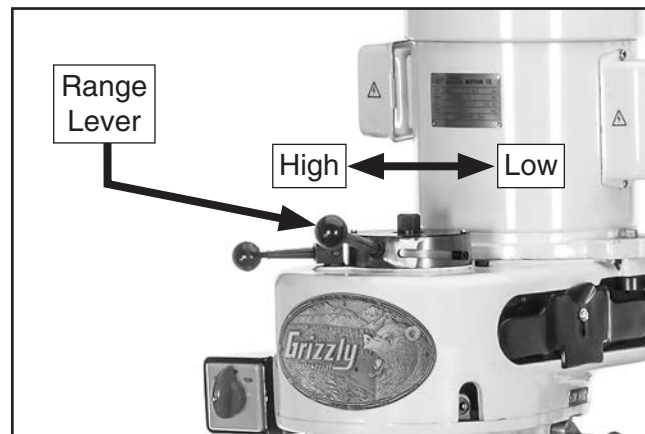
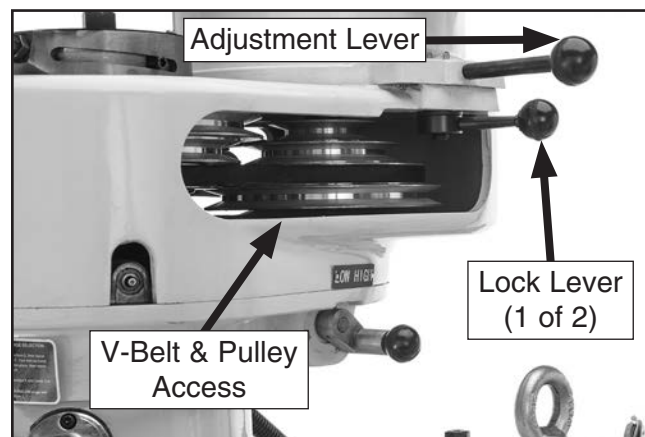

**Figure 39.** Model G0796 range lever.

5. Firmly grasp spindle, then quickly rotate it back and forth until you hear/feel front pulley drop into spindle clutch.

— If this step was not successful, use HIGH-LOW range lever to re-set speed range, then repeat this step until you are certain that spindle is seated into spindle clutch.

6. Remove belt housing side covers on either side of head to expose V-belt and pulleys, as shown in **Figure 40**.
7. Loosen two motor lock levers, one on each side of head, then pull belt tension adjustment lever forward to release V-belt tension (see **Figure 40**).

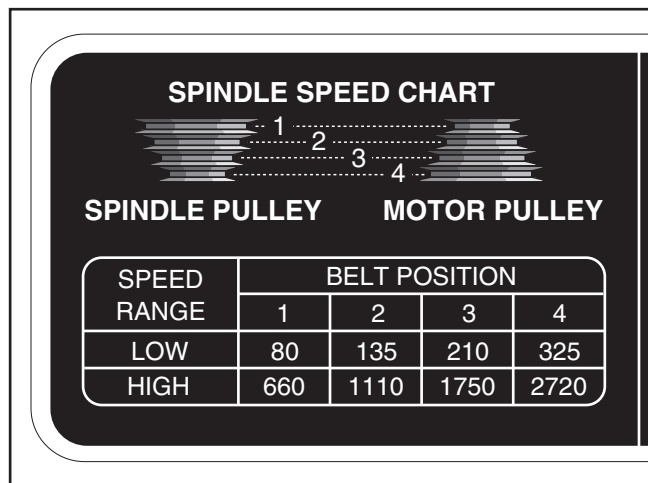

**Figure 40.** Model G0796 V-belt and pulleys exposed for setting spindle speed.





- Refer to spindle speed chart on front of head-stock (see **Figure 41**), and position V-belt on pulleys for desired spindle speed.



**Figure 41.** Model G0796 spindle speed chart.

- Push adjustment lever backward with moderate force to re-tension V-belt, then re-tighten two lock levers to secure motor (see **Figure 40** on **Page 38**).
- Replace two belt housing side covers before re-connecting mill to power.

**CAUTION**  
To avoid entanglement hazards, always ensure belt housing safety covers are firmly in place before connecting the mill to power.

### Setting G0797 Spindle Speed

The Model G0797 has variable spindle speeds from 60 to 4200 RPM. Setting the spindle speed involves 1) Selecting the spindle speed range, and 2) using the variable-speed handwheel to select the spindle speed.

**NOTICE**  
For Model G0797 ONLY, always make sure that spindle rotation has started and is at a constant speed before using variable-speed handwheel to adjust spindle speed. Otherwise, moving parts inside belt housing could be damaged and void warranty.

### To set Model G0797 spindle speed:

- Make sure spindle is completely stopped, then use chart below to find spindle speed range that includes required spindle speed for your operation (see **Figure 42**).
- Pull spindle speed range selector knob (see **Figure 42**) out, move to HIGH or LOW position, then release knob to seat knob pin in detent.

**Note:** If it is difficult to move range selector knob, rotate spindle by hand to help mesh gears until selector moves freely.

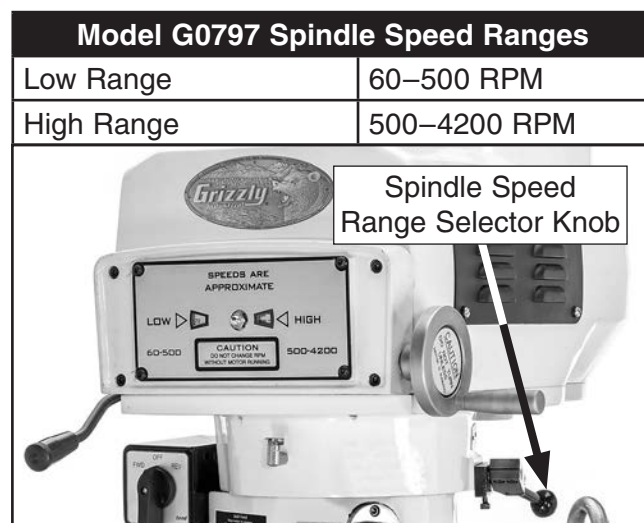

**Figure 42.** Model G0797 available spindle speeds and location of range selector knob.

- Use spindle switch to start spindle rotation.
- Slowly rotate variable-speed handwheel shown in **Figure 43** until desired speed is displayed in indicator for speed range selected.

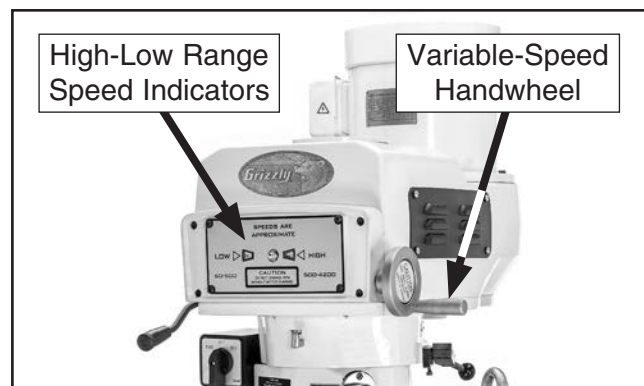

**Figure 43.** Location of Model G0797 variable-speed controls.



# Spindle Downfeed

Spindle downfeed movement on the mill is controlled by three mechanisms: 1) The coarse downfeed lever, 2) the fine downfeed handwheel, and 3) the auto-downfeed system.

## Downfeed Controls

Use **Figure 44** and the following descriptions to become familiar with the spindle downfeed controls.

### **NOTICE**

When spindle rotation is reversed, either by changing the spindle speed range or by using the spindle direction switch, the direction of spindle auto-downfeed will reverse.

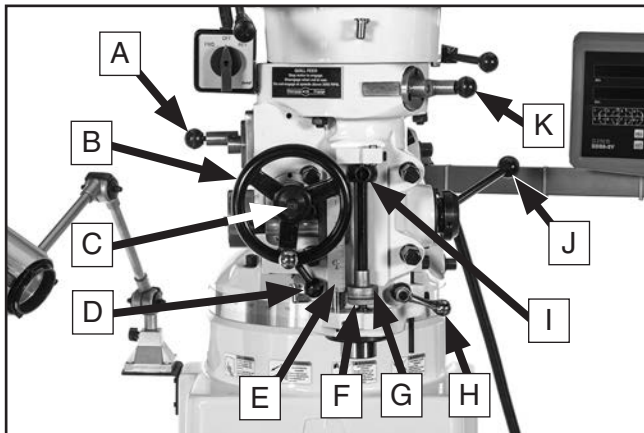

**Figure 44.** Downfeed controls.

- A. Auto-Downfeed Rate Selector.** Selects one of the three auto-downfeed rates:

0.0015 in/rev  
0.003 in/rev  
0.006 in/rev

- B. Fine Downfeed Handwheel.** Manually controls slow spindle downfeed.
- C. Auto-Downfeed Direction Pin.** Starts, stops, and reverses the auto-downfeed direction.
- D. Fine Downfeed Clutch Lever.** Engages the fine/auto-downfeed gears.

- E. Downfeed Scale.** Used with the downfeed stop and quill dog, shows the depth of spindle downfeed in inches.
- F. Downfeed Stop Locking Wheel.** Tightens against downfeed stop to lock it in place.
- G. Downfeed Stop.** Sets the depth of spindle downfeed. The stop is threaded into position, then the locking wheel is used to secure it in place.
- H. Quill Lock Lever.** Secures the quill in place for increased stability during operations.
- I. Quill Dog.** Moves with the quill and spindle. When it contacts the downfeed stop in coarse and auto downfeed modes, it disengages the downfeed clutch and the spindle auto-retracts.
- J. Coarse Downfeed Lever.** Manually controls quick spindle downfeed.
- K. Downfeed Selector.** Sets the mill for manual downfeed or auto-downfeed control.

## Setting Downfeed Stop

The downfeed stop (see **Figure 44**) sets the depth of spindle travel for repeat operations. The upper edge of the downfeed stop aligns with marks on the downfeed scale to help you set the approximate depth, however the downfeed scale functions as a general guide only, and is not intended for low-tolerance, precision results.

To set the downfeed stop, rotate stop until upper edge aligns with desired depth indicated on scale (see **Figure 44**), then tighten locking wheel against stop to secure it.



## Using Coarse Downfeed

Coarse downfeed is typically used for drilling, because it allows you to quickly lower the spindle with varying speed/pressure, and it automatically retracts the spindle to the top position when released.

**Note:** *To maintain control of the upward spindle travel and the rotating bit in your workpiece, always continue holding the lever until the spindle returns to the top position. Letting go of the lever too soon will cause the spindle to retract too quickly and slam up into the headstock.*

### To use coarse downfeed:

1. DISCONNECT MACHINE FROM POWER!
2. Make sure spindle is completely stopped, then pull downfeed selector out and rotate it until it seats in manual (disengaged) position (see **Figure 45**).

**Note:** *It may be necessary to turn the spindle by hand as you move the selector to enable the gears to mesh.*

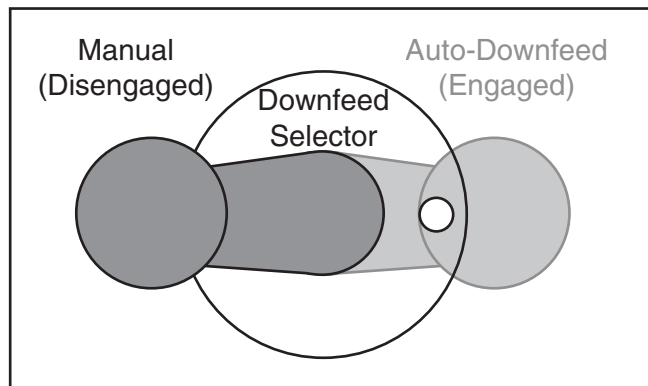

**Figure 45.** Downfeed selector in manual (disengaged) position.

3. Make sure pin of coarse downfeed lever hub is engaged with one of the detents on downfeed sleeve, and loosen quill lock lever (see **Figure 46**).
4. Rotate coarse downfeed lever around hub to control spindle depth.

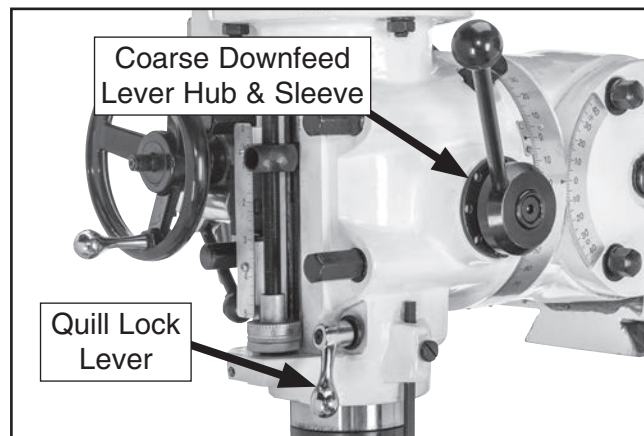

**Figure 46.** Coarse downfeed lever hub, downfeed sleeve, and quill lock.



## Using Fine Downfeed

Fine downfeed is used for precise Z-axis positioning of a cutter or end-mill when milling a flat surface across the face of a workpiece. In order to ensure the milled surface remains flat, the quill lock lever should be locked after each adjustment to ensure the spindle height cannot move until the entire milling operation is complete.

### To use fine downfeed:

1. DISCONNECT MACHINE FROM POWER!
2. Make sure spindle is completely stopped, then pull downfeed selector knob out and rotate it until it seats in manual (disengaged) position (see **Figure 45** on **Page 41**).

**Note:** *It may be necessary to turn the spindle by hand as you move the selector to enable the gears to mesh.*

3. Set auto-downfeed direction pin (see **Figure 44** on **Page 40**) in neutral (middle) position to disengage fine downfeed handwheel from auto-downfeed gears.
4. Use coarse downfeed lever to lower spindle slightly until you can pull fine/auto downfeed clutch lever (see **Figure 44** on **Page 40**) to the left so it locks in place.
5. Rotate fine downfeed handwheel to raise or lower spindle.

## Using Auto-Downfeed

When using the auto-downfeed system, the spindle will move in the direction you choose with the auto-downfeed direction pin. When the quill dog reaches the top or meets the downfeed stop, the downfeed clutch lever will release. Then, if the spindle was traveling upward, the movement will simply stop. If the spindle was traveling downward, then the spindle will move back to the top at a rate controlled by the return spring on the left side of the head.

### To use auto-downfeed:

1. Make sure spindle is completely stopped.
2. Pull downfeed selector knob out, then rotate it clockwise until knob pin seats in auto-downfeed (engaged) detent (see **Figure 47**).

**Note:** *It may be necessary to turn the spindle by hand as you move the selector to enable the gears to mesh.*

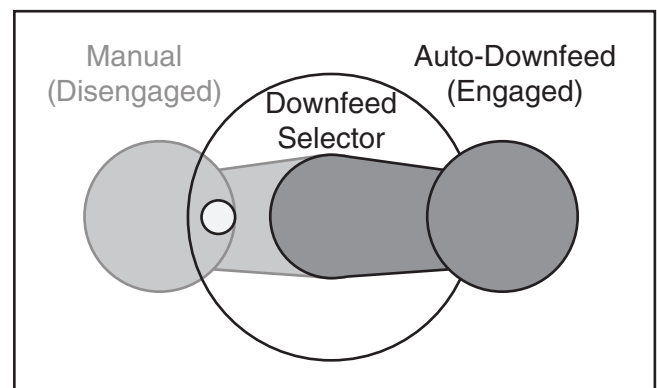

**Figure 47.** Downfeed selector in auto-downfeed (engaged) position.

3. Position downfeed stop for spindle depth that is correct for your operation, then secure it in place with locking wheel (see **Figure 44** on **Page 40** and description on **Page 40**).



- Position auto-downfeed direction pin (see **Figure 44** on **Page 40**) in center of handwheel for spindle travel that is correct for your operation. If necessary, rock fine downfeed handwheel back-and-forth to move pin all the way in or out.

**Note:** The direction pin has three positions: 1) In for one downfeed direction, 2) middle for neutral or no movement, and 3) out for the reverse direction. The direction of spindle travel for the in and out positions is relative to the direction of spindle rotation. Keep in mind that spindle rotation and downfeed direction will reverse when the spindle speed range is changed.

- Make sure fine/auto downfeed clutch lever is all the way to right in disengaged position (see **Figure 48**) so that spindle will not travel when rotation is started.

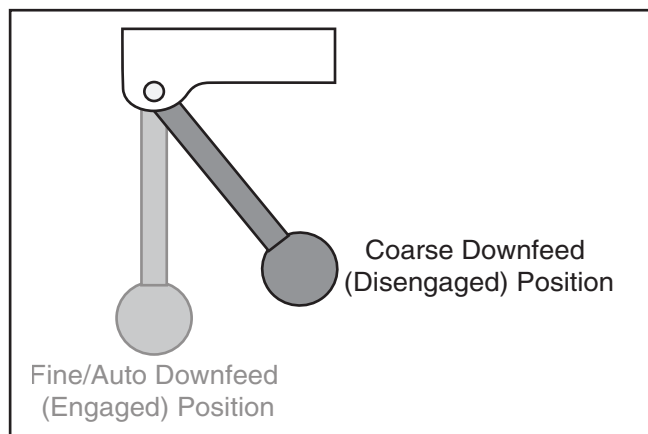

**Figure 48.** Fine/auto downfeed clutch lever disengaged for auto-downfeed operations.

**Note:** We recommend that you complete the remaining steps without a cutting tool installed, without a workpiece in place, and the table lower than the maximum spindle downfeed travel. This will enable you to test and confirm the settings before beginning the actual cutting operation.

## NOTICE

To avoid damage to system gearing, never use auto-downfeed system with spindle speeds over 1750 RPM.

- Set mill for correct spindle speed, then begin spindle rotation.

## NOTICE

**ALWAYS** start spindle rotation before using auto-downfeed to avoid risk of gear damage.

- Select one of the three downfeed rates by pulling knob of auto-downfeed rate selector out, position selector over appropriate detent, then release knob. Make sure pin is firmly seated by attempting to move selector without pulling knob out.

**Note:** Refer to the illustration in **Figure 49** when selecting the downfeed rate.

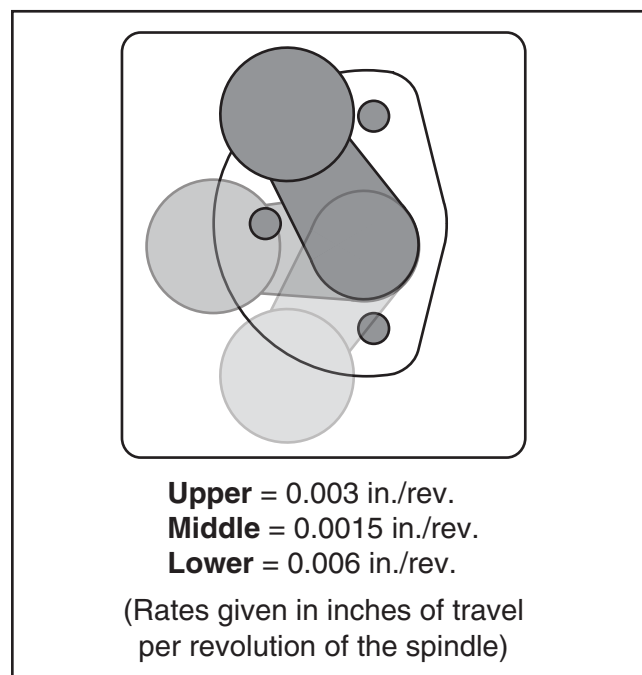

**Figure 49.** Positions of auto-downfeed rate selector.

- Use coarse downfeed lever to lower spindle slightly until you can pull clutch lever out to the left and it locks in place, which will start auto-downfeed spindle travel.



# Spindle Brake

After turning the spindle switch **OFF**, move the brake lever left or right (G0796) or up or down (G0797) to bring the spindle to a full stop (see **Figures 50–51**).

## NOTICE

To avoid premature wear of brake system, use spindle brake **ONLY** after power to spindle has been turned **OFF**.

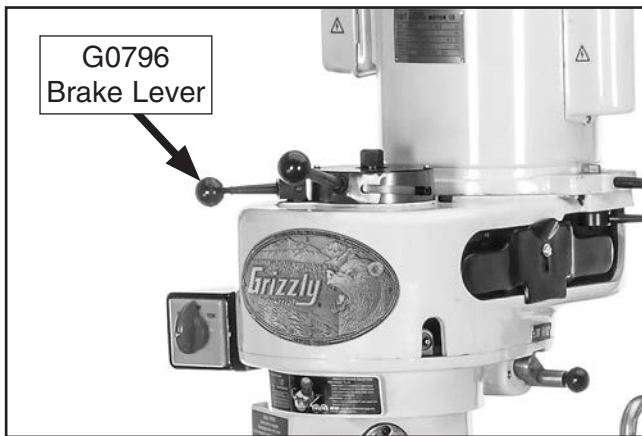

**Figure 50.** Model G0796 brake lever.



**Figure 51.** Model G0797 brake lever.

## NOTICE

To evenly wear brake shoes, alternate direction you move lever when braking.

# Loading/Unloading Tooling

Each mill is equipped with an R-8 spindle taper and a 7/16"-20 spindle drawbar (see **Figure 52**).

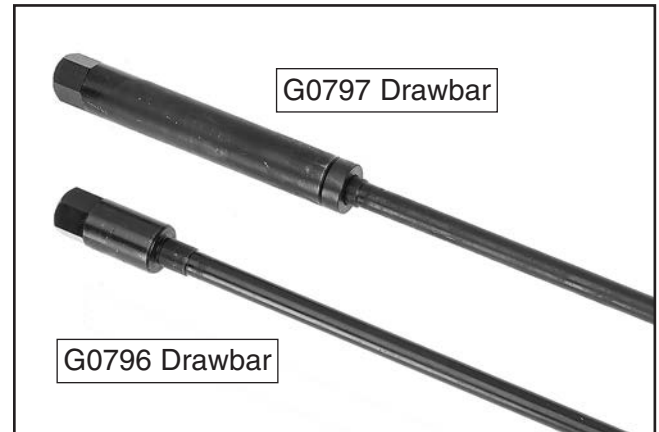

**Figure 52.** Upper portions of drawbars.

Tools Needed	Qty
Wrench 19mm .....	1
Brass Hammer .....	1

## Loading Tooling

1. DISCONNECT MACHINE FROM POWER!
  2. Clean any debris or oily substances from inside spindle taper and mating surface of the tooling.
- Note:** Debris or oily substances can prevent the tooling and spindle from properly mating. This condition can cause excessive vibration, poor cutting results, or tool/workpiece damage.
3. Place mill in low spindle speed range to keep spindle from turning in next steps.
  4. Align keyway of tool with protruding pin inside spindle taper, firmly push tool into spindle to seat it.



5. With one hand holding tool in place, insert drawbar into spindle from top of head, then thread it into tool by hand until snug (see **Figure 53**).

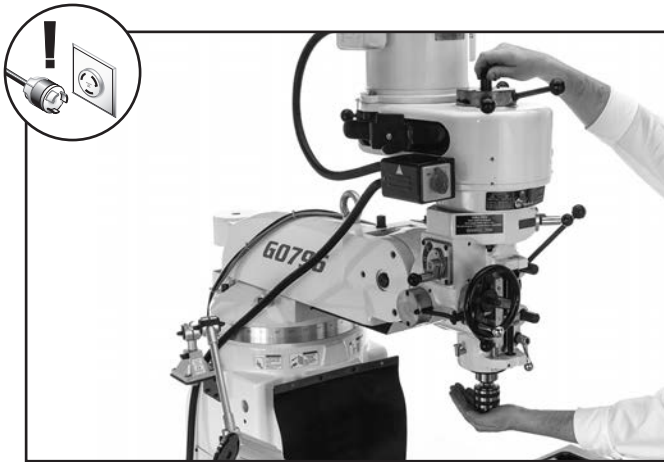

**Figure 53.** Drawbar loaded (Model G0796 shown).

6. Use 19mm wrench to tighten drawbar an additional  $\frac{1}{4}$  turn.

**Note:** Do not overtighten drawbar. Overtightening makes tool removal difficult and may damage arbor and threads.

## Unloading Tooling

1. DISCONNECT MACHINE FROM POWER!
2. Place mill in low spindle speed range to keep spindle from turning during next step.
3. Loosen drawbar one full rotation.

**Note:** Make sure that the drawbar has at least three threads engaged with the tooling, or the drawbar and tool threads could be damaged in the next step.

4. Tap top of drawbar with hammer to unseat taper (see **Figure 54**).



**Figure 54.** Tapping drawbar to unseat tool taper (G0796 shown).

5. Support tool with one hand and fully unthread drawbar from tool.



# SECTION 5: ACCESSORIES

## **! WARNING**

Installing unapproved accessories may cause machine to malfunction, resulting in serious personal injury or machine damage. To reduce this risk, only install accessories recommended for this machine by Grizzly.

## **NOTICE**

Refer to our website or latest catalog for additional recommended accessories.

### **T27460—Digital Indicator**

This indicator offers the ultimate in precision and accuracy, making it perfect for tramming mill spindles!



**Figure 55.** Model T27460 Digital Indicator.

### **SB1365—South Bend Way Oil-ISO 68**

### **T26419—Syn-o-Gen 777 Grease**

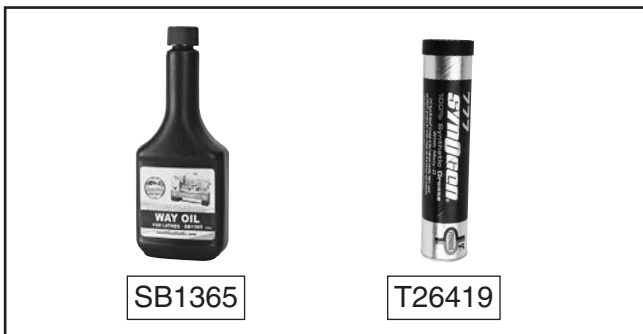

**Figure 56.** Recommended products for machine lubrication.

### **G1076—58 Pc. Clamping Kit for 5/8" T-Slots**

This clamping kit includes 24 studs, six step block pairs, six T-nuts, six flange nuts, four coupling nuts, and six end hold-downs. The rack is slotted so it can be mounted close to the machine for easy access.

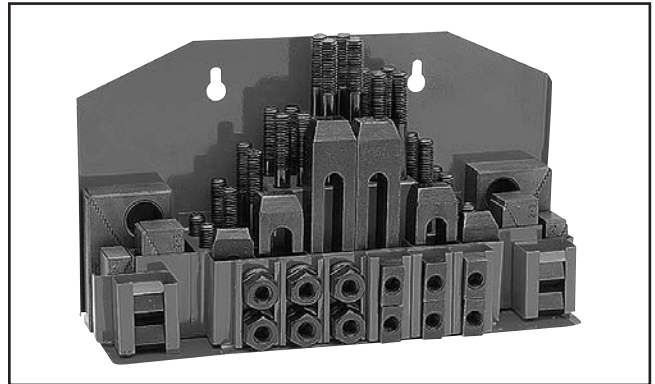

**Figure 57.** G1076 58 Pc. Clamping Kit for 5/8" T-Slots.

### **H7527—6" Rotary Table Set**

Use this 6" Rotary Table in either the horizontal or vertical position for a variety of milling applications and with the set of dividing plates and adjustable tailstock, your milling applications are nearly unlimited. With 4° table movement per handle rotation and 20 second vernier scale, control is very accurate and precise. Also includes a 3/8" clamping set for the 4-slot table. Everything you need in one great set!

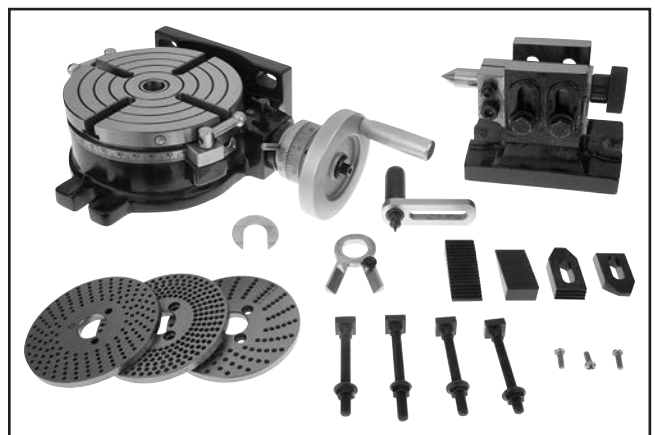

**Figure 58.** H7527 6" Rotary Table Set.

**order online at [www.grizzly.com](http://www.grizzly.com) or call 1-800-523-4777**





**H8140—7 Gal. Coolant Tank System**

This complete 7 Gallon Coolant Tank System includes pump, switch, enclosed tank, coolant return hose and flexible nozzle with magnetic base. Made in an ISO 9001 factory.

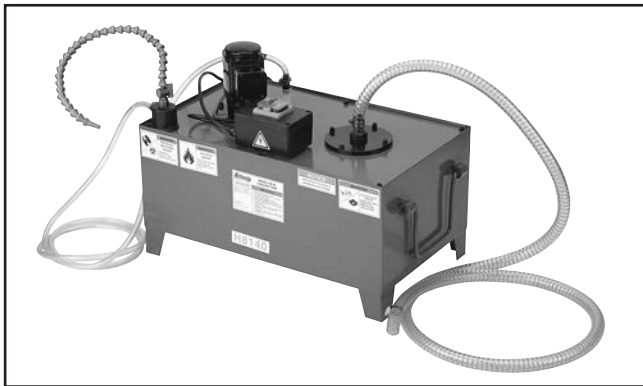

**Figure 59.** H8140 7-Gallon Coolant Tank System.

**T25702—R-8 End Mill Holder, 5-Pc. Set**

Hold various sized end mills in your R-8 spindle with this End Mill Holder Set. Includes holders for 3/16", 3/8", 1/2", 5/8", and 3/4" end mills.



**Figure 60.** T25702 R-8 End Mill Holder, 5-Pc. Set.

**T24799—1-2-3 Block Set**

**T24800—2-4-6 Block Set**

**G9815—Thin Parallel Set-10 Pairs**

**H5556—4-Pc. Edge Finder Set**

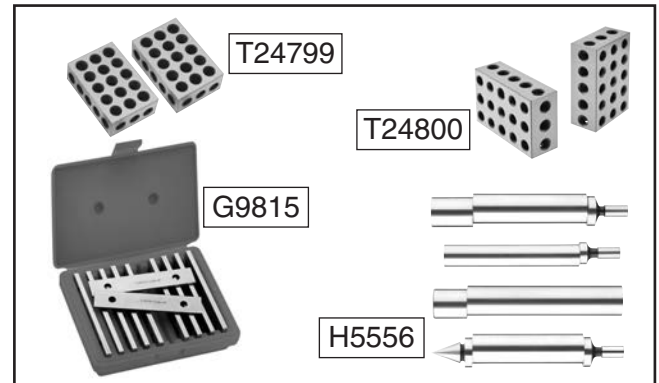

**Figure 61.** 1-2-3 and 2-4-6 block sets, thin parallel set, and 4-Pc. edge finder set.

**G7156—Premium Milling Vise-4"**

**G7154—Premium Milling Vise-5"**

**G7155—Premium Milling Vise-6"**

These swiveling milling vises feature perfectly aligned, precision-ground jaws, robust clamping screws, and easy-to-read 0°–360° scales.

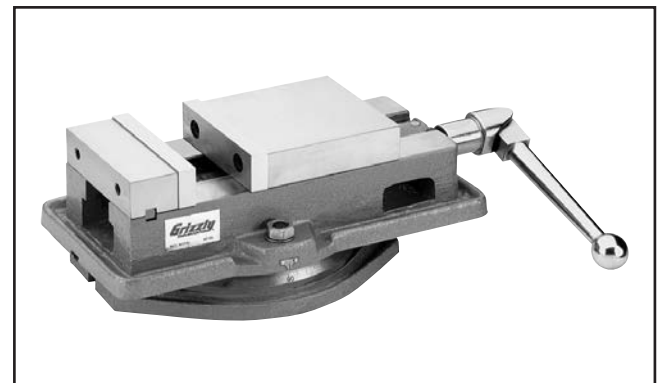

**Figure 62.** G7155 6" Premium Milling Vise.

**order online at [www.grizzly.com](http://www.grizzly.com) or call 1-800-523-4777**



### T10168—3" Boring Head Set

This all inclusive set features precision boring heads with R-8 shanks and  $\frac{7}{8}$ "-20 mounting threads. Comes with five  $\frac{3}{4}$ " carbide tipped boring bars, five  $\frac{1}{2}$ " boring bars, and a  $\frac{1}{2}$ "- $\frac{3}{4}$ " adapter and includes carrying case.



Figure 63. T10168 3" Boring Head Set.

### G9760—20-Pc. 2 & 4 Flute TiN End Mill Set

Includes these sizes and styles in two and four flute styles:  $\frac{3}{16}$ ",  $\frac{1}{4}$ ",  $\frac{5}{16}$ ",  $\frac{3}{8}$ ",  $\frac{7}{16}$ ",  $\frac{1}{2}$ ",  $\frac{9}{16}$ ",  $\frac{5}{8}$ ",  $\frac{3}{8}$ ",  $\frac{11}{16}$ ", and  $\frac{3}{4}$ ".



Figure 64. G9760 20-Pc. 2 & 4 Flute TiN End Mill Set.

### T10388—4" Milling Cutter

#### T10390—R-8 Holder for T10388

Together with the T10390 R-8 holder, the T10388 provides incredible cutting action and exceptional finishes thanks to its enhanced helix insert design. This top-quality cutter is suitable for production and tool rooms! Inserts not included.

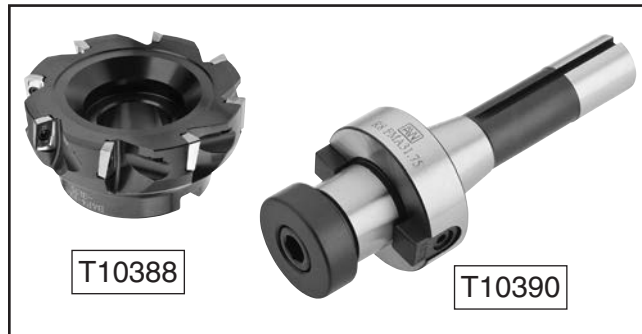

Figure 65. 4" milling cutter and R-8 holder.

### T26688—R-8 Quick Change Collet Set

Threaded for  $\frac{7}{16}$ "-20 draw bars, this set has a maximum runout of 0.001". 8 Pc. set includes collect chuck,  $\frac{1}{4}$ ",  $\frac{5}{16}$ ",  $\frac{3}{8}$ ",  $\frac{1}{2}$ ",  $\frac{5}{8}$ ",  $\frac{3}{4}$ ", and 1" collets, spanner wrench, and moulded plastic case.

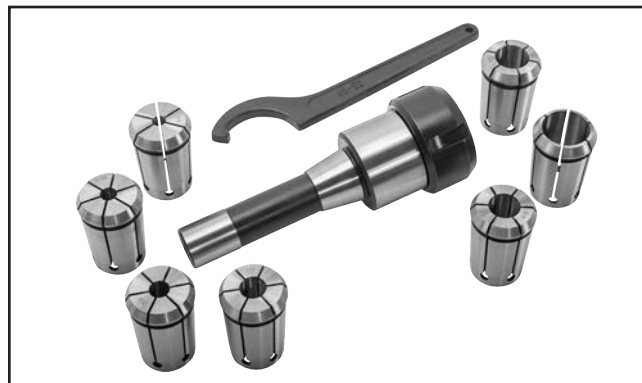

Figure 66. T26688 R-8 Quick Change Collet Set.

order online at [www.grizzly.com](http://www.grizzly.com) or call 1-800-523-4777



# SECTION 6: MAINTENANCE

---

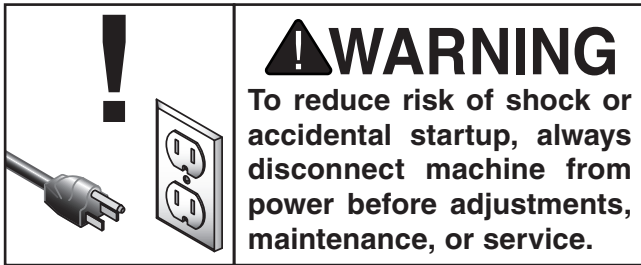

## Schedule

---

For optimum performance from your machine, follow this maintenance schedule and refer to any specific instructions given in this section.

### Ongoing

To help minimize your risk of injury and maintain proper machine operation, if you ever observe any of the items below shut the machine down immediately, disconnect it from power, and fix the problem before continuing operations.

- Loose mounting bolts or fasteners.
- Worn, frayed, cracked, or damaged wires.
- Missing belt guards.
- Reduction in braking speed or efficiency.
- Any other unsafe condition.

### Before Beginning Operations

- Turn the spindle direction switch to the OFF (middle) position to prevent spindle startup when connected to power (see **Page 29**).
- Move the fine/auto downfeed clutch lever to the right (disengaged) position to prevent the spindle from unexpectedly auto-downfeeding when rotation is started (see **Figure 48** on **Page 43**).
- Make sure the X-axis power feed is turned **OFF** to prevent unintentional table movement when connected to power (see **Page 34**).
- Perform lubrications tasks as directed in the **Lubrication** section on **Page 50**.
- Check table movement in all three axis directions for loose/tight gibs. Adjust the gibs if necessary (see **Page 57**).

### Daily, After Operations

- Disconnect the machine from power.
- Vacuum/clean all chips and swarf from table, slides, and base.
- Wipe down all unpainted or machined surfaces with a good quality rust preventative.

## Cleaning & Protecting

---

Regular cleaning is one of the most important steps in taking good care of this mill. Each operator is responsible for cleaning the machine immediately after using it or at the end of the day. We recommend that the cleaning routine be planned into the workflow schedule, so that adequate time is set aside to do the job right.

Typically, the easiest way to clean swarf from the ways and table is to use a wet/dry shop vacuum that is dedicated for this purpose only. The small chips leftover after vacuuming can be wiped up with a slightly oiled rag. Avoid using compressed air to blow off chips, as this may drive them deeper into moving surfaces and could cause sharp chips to fly into your face or hands.

Besides the ways and elevation leadscrew, all other unpainted and machined surfaces should be wiped down daily to keep them rust-free and in top condition. This includes any surface that could be vulnerable to rust if left unprotected (this especially includes any parts that may be exposed to water soluble cutting fluids). Typically with these parts, a thin film of oil is all that is necessary for protection.

Keep tables rust-free with ISO 68 way oil.



# Lubrication

The mill has numerous moving metal-to-metal contacts that require regular and proper lubrication to ensure efficient and long-lasting operation, and to protect your investment.

Other than the lubrication points covered in this section, all other bearings are internally lubricated and sealed at the factory. Simply leave them alone unless they need to be replaced.

Before performing any lubrication task, **DISCONNECT MACHINE FROM POWER!**

**Important:** Before adding lubricant, clean the debris and grime from the oil cup or grease fitting and the immediate area to prevent contamination of the new lubricant.

Use the schedule and information in **Figure 67** as a daily guide for lubrication tasks. Follow the referenced sections on the following pages for detailed instructions.

## NOTICE

The following recommended lubrication schedule is based on light to medium mill usage. Keeping in mind that lubrication helps to protect value and operation of mill, you may need to perform lubrication tasks more frequently depending on your usage.

Lubrication Task	Frequency (Hours of Operation)	Page Ref.
Quill	4 Hrs.	This Page
Quill Gearing (G0797)	4–8 Hrs.	This Page
Table Ways	4–8 Hrs.	51
Headstock Gearing	40 Hrs.	51
Ram Ways	40 Hrs.	51
Table Elevation Leadscrew (Z-Axis)	40 Hrs.	52
Power Feed Gears	160 Hrs.	52

**Figure 67.** Recommended lubrication tasks, schedules, and instruction page references.

## NOTICE

Failure to follow reasonable lubrication practices as instructed in this manual for the mill could lead to premature failure of the mill and will void the warranty.

### Quill

Oil Type ..... Model SB1365 or ISO 68 Equivalent  
 Oil Amount..... Fill Oil Cup  
 Check/Add Frequency .....4 Hrs. of Operation

Lift the quill oil cup cap shown in **Figure 68** to add 10 drops of lubricant.

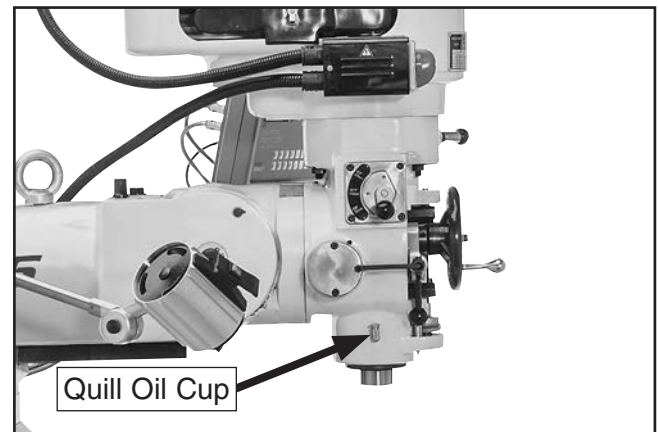

**Figure 68.** Location of quill oil cup (Model G0796 shown).

### Quill Gearing (G0797 Only)

Oil Type ..... Model SB1365 or ISO 68 Equivalent  
 Amount ..... Fill Oil Cup  
 Add Frequency ..... 4–8 Hrs. of Operation

Lift the oil cup cap shown in **Figure 69** to add oil.



**Figure 69.** Location of Model G0797 quill gearing oil cup.



## Table Ways (One-Shot Oiler)

Oil Type ..... Model SB1365 or ISO 68 Equivalent  
 Oil Amount..... One Pull of Pump Handle  
 Check/Add Frequency ..... 4–8 Hrs. of Operation

The one-shot oiler is connected to a series of aluminum tubes that carry the lubricant to wear points along the table horizontal and vertical ways.

Pull the handle out slowly then release it to send the oil through the tubes (see **Figure 70**), then move the table through all paths of movement to evenly distribute the lubricant.

Use the sight glass on the side of the oiler to know when to re-fill the reservoir. The reservoir capacity is ½ liter.

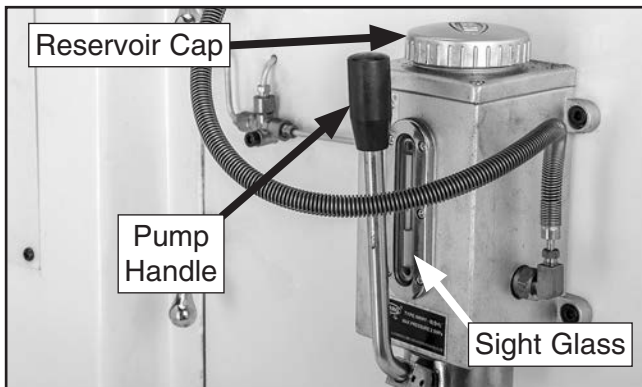

**Figure 70.** One-shot oiler components.

## Headstock Gearing (G0797)

Grease Type ..... NLGI #2 or Equivalent  
 Grease Amount ..... Two Pumps of Grease Gun  
 Check/Add Frequency ..... 40 Hrs. of Operation

Add two pumps from a grease gun to the grease fitting shown in **Figure 71**.



**Figure 71.** Model G0797 headstock gearing grease fitting.

## Ram Ways

Oil Type ..... Model SB1365 or ISO 68 Equivalent  
 Oil Amount..... Thin Coat  
 Check/Add Frequency ..... 40 Hrs. of Operation

Move the ram back and forth as necessary to access the full length of the ways (see **Figure 72**), then use a clean shop rag to apply a thin coat of lubricant to the ways.

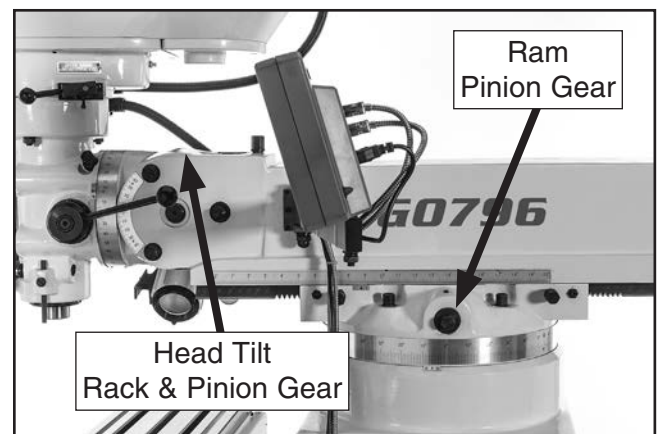

**Figure 72.** Ram ways.

## Head Tilt & Ram Pinions

The interaction between the cast iron surfaces of these devices (see **Figure 73**) produces a dry powder that provides an adequate lubrication.

Do not apply any other lubricant because it could produce a stiff compound, which may interfere with smooth movement.



**Figure 73.** Head tilt and ram pinions.



## Table Elevation Leadscrew

Grease Type .....NLGI #2 or Equivalent  
 Grease Amount .....Thin Coat  
 Check/Add Frequency .....40 Hrs. of Operation

Elevate the table all the way up, then use mineral spirits to clean any debris and built-up grime from the elevation leadscrew threads. Add one pump from a grease gun to the leadscrew grease fitting shown in **Figure 74**, then run the table up and down to distribute the grease. Repeat this process until the entire leadscrew is well lubricated.

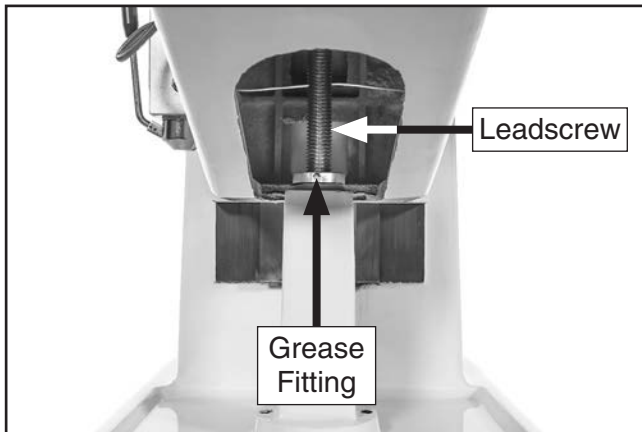

**Figure 74.** Elevation leadscrew grease fitting shown from front of machine.

## Power Feed Gears

Grease Type .....NLGI #2 or Equivalent  
 Grease Amount .....Two Pumps of Grease Gun  
 Check/Add Frequency .....160 Hrs. of Operation

<b>Tool Needed</b>	<b>Qty</b>
Wrench 19mm .....	1

### To lubricate power feed gears:

1. DISCONNECT MACHINE FROM POWER!
2. Push ball handle *in* to engage detent sleeve and prevent leadscrew from rotating, then remove ball handle nut, ball handle, and compression spring from power unit end of X-axis leadscrew (see **Figure 75**).

3. Remove detent sleeve and spacer (see **Figure 75**).

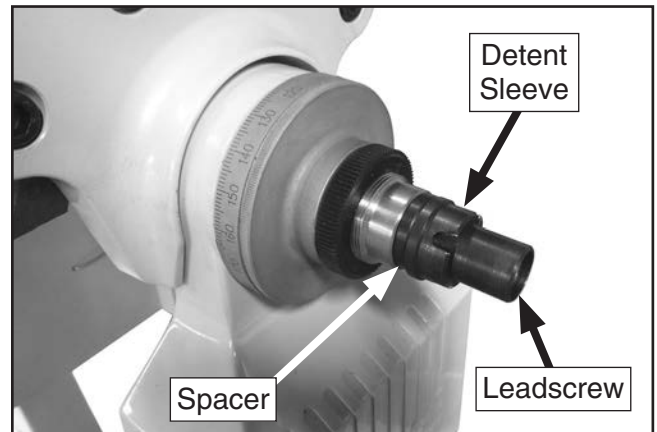

**Figure 75.** X-axis leadscrew with retaining nut, power feed ball handle, and compression spring removed.

**Tip:** Rotate graduated dial ring (see **Figure 76**) by hand until leadscrew alignment key is facing upward, to help prevent losing key in the following steps.

4. Unthread and remove knurled retaining ring and graduated dial ring from end of leadscrew (see **Figure 76**).

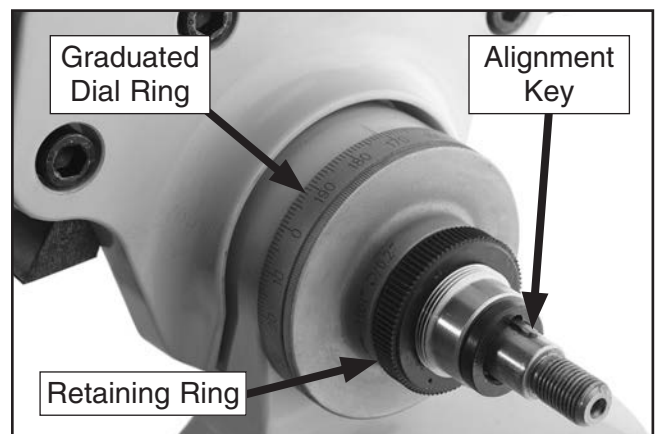
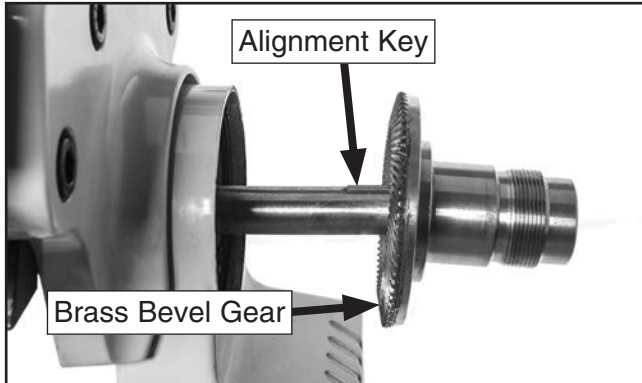

**Figure 76.** Location of X-axis leadscrew graduated dial and retaining rings.



# Machine Storage

5. Remove brass bevel gear from leadscrew, making sure not to lose alignment key (see **Figure 77**).



**Figure 77.** Power feed brass gear and leadscrew alignment key.

6. Brush a light coat of grease on teeth of bevel gear and smaller drive gear (see **Figure 78**).

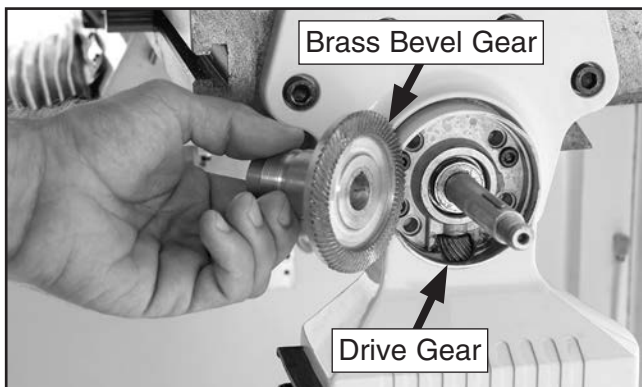

**Figure 78.** Power feed brass bevel gear and drive gear.

7. Make sure leadscrew alignment key is installed, then align bevel gear keyway with key as you slide gear onto leadscrew and mesh its teeth with drive gear.
8. Align graduated dial ring keyway with key, then slide it into position and secure it with knurled retaining ring—do not overtighten.
9. Replace spacer, detent sleeve, compression spring, ball handle, and ball handle nut in reverse order from removal.
10. Manually move table with power feed ball handle to check gear movement and to distribute grease on gears. If movement is not smooth, repeat **Steps 2–8** until it is.

To avoid rust problems or corrosion damage, use the following information to protect your investment when storing the mill for any length of time.

- **DISCONNECT MACHINE FROM POWER!**
- Lubricate the mill as directed in the Lubrication section beginning on **Page 50**.
- Thoroughly clean all unpainted, bare metal surfaces, then coat them with a light weight grease or rust preventative. Take care to ensure these surfaces are completely covered but that the grease or rust preventative is kept off painted surfaces.

**Note:** *If the machine will be out of service for only a short period of time, use way oil or a good grade of medium-weight machine oil (not auto engine oil) in place of the grease or rust preventative.*

- Loosen the belts to prevent them from stretching during storage. Post a reminder on the mill that the belts need to be re-tensioned before resuming operations.
- Cover and place the machine in a dry area that is out of direct sunlight and away from hazardous fumes, paint, solvents, or gas. Fumes and sunlight can bleach or discolor paint and plastic parts.
- At least once a month, start the mill and run all gear-driven components for a few minutes. This will keep the bearings, bushings, gears, and shafts well lubricated and protected from corrosion, especially during the winter months.



# SECTION 7: SERVICE

Review the troubleshooting procedures in this section if a problem develops with your machine. If you need replacement parts or additional help with a procedure, call our Technical Support. **Note:** *Please gather the serial number and manufacture date of your machine before calling.*

## Troubleshooting

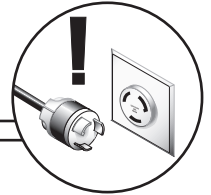

### Motor & Electrical

Symptom	Possible Cause	Possible Solution
Machine does not start or a breaker trips.	<ol style="list-style-type: none"> <li>1. Plug/receptacle at fault/wired wrong.</li> <li>2. Incorrect power supply voltage/circuit size.</li> <li>3. Power supply circuit breaker tripped or fuse blown.</li> <li>4. Motor wires connected incorrectly.</li> <li>5. Wiring open/has high resistance.</li> <li>6. Spindle rotation switch at fault.</li> <li>7. Start capacitor at fault (G0796).</li> <li>8. Centrifugal switch at fault (G0796).</li> <li>9. Motor at fault.</li> </ol>	<ol style="list-style-type: none"> <li>1. Test for good contacts; correct the wiring.</li> <li>2. Ensure correct power supply voltage/circuit size.</li> <li>3. Ensure circuit is sized correctly and free of shorts. Reset circuit breaker or replace fuse.</li> <li>4. Correct motor wiring connections.</li> <li>5. Check/fix broken, disconnected, or corroded wires.</li> <li>6. Replace switch.</li> <li>7. Test/replace.</li> <li>8. Adjust/replace centrifugal switch if available.</li> <li>9. Test/repair/replace.</li> </ol>
Machine stalls or is underpowered.	<ol style="list-style-type: none"> <li>1. Machine undersized for task.</li> <li>2. Feed rate/cutting speed too fast.</li> <li>3. Wrong workpiece material.</li> <li>4. Belt(s) slipping.</li> <li>5. Oil/grease on belt(s).</li> <li>6. Motor wired incorrectly.</li> <li>7. Spindle rotation switch at fault.</li> <li>8. Gearbox at fault.</li> <li>9. Motor overheated.</li> <li>10. Pulley/sprocket slipping on shaft.</li> <li>11. Centrifugal switch at fault.</li> <li>12. Motor bearings at fault.</li> </ol>	<ol style="list-style-type: none"> <li>1. Use correct cutter/bit; reduce feed rate; reduce spindle RPM; use coolant if possible.</li> <li>2. Decrease feed rate/cutting speed.</li> <li>3. Use correct type/size of metal.</li> <li>4. Tension/replace belt(s); ensure pulleys are aligned.</li> <li>5. Clean belt(s).</li> <li>6. Wire motor correctly.</li> <li>7. Test/replace switch.</li> <li>8. Select appropriate gear ratio; replace broken or slipping gears.</li> <li>9. Clean motor, let cool, and reduce workload.</li> <li>10. Replace loose pulley/shaft.</li> <li>11. Adjust/replace centrifugal switch if available.</li> <li>12. Test/repair/replace.</li> </ol>
Machine has vibration or noisy operation.	<ol style="list-style-type: none"> <li>1. Workpiece loose.</li> <li>2. Belt(s) worn or loose.</li> <li>3. Motor or component loose.</li> <li>4. Chuck or cutter at fault.</li> <li>5. Belt(s) slapping headstock casting/guard.</li> <li>6. Motor fan rubbing on fan cover.</li> <li>7. Pulley loose.</li> <li>8. Machine incorrectly mounted.</li> <li>9. Motor bearings at fault.</li> <li>10. Centrifugal switch is at fault (G0796).</li> </ol>	<ol style="list-style-type: none"> <li>1. Use the correct holding fixture/reclamp workpiece.</li> <li>2. Inspect/replace belts with a new matched set.</li> <li>3. Inspect/replace damaged bolts/nuts, and retighten with thread locking fluid.</li> <li>4. Replace unbalanced chuck; replace/resharpen cutter; use correct feed rate.</li> <li>5. Replace/realign belts with a matched set.</li> <li>6. Fix/replace fan cover; replace loose/damaged fan.</li> <li>7. Re-align/replace shaft, pulley set screw, and key.</li> <li>8. Tighten mounting bolts; relocate/shim machine.</li> <li>9. Test by rotating shaft; rotational grinding/loose shaft requires bearing replacement.</li> <li>10. Replace.</li> </ol>





# Mill

Symptom	Possible Cause	Possible Solution
Tool loose in spindle.	<ol style="list-style-type: none"> <li>1. Tool is not fully drawn up into spindle taper.</li> <li>2. Debris on tool or in spindle taper</li> <li>3. Taking too big of a cut.</li> </ol>	<ol style="list-style-type: none"> <li>1. Tighten drawbar.</li> <li>2. Clean tool and spindle taper.</li> <li>3. Lessen depth of cut and allow chips to clear.</li> </ol>
Breaking tools or cutters.	<ol style="list-style-type: none"> <li>1. Spindle speed/feed rate is too fast.</li> <li>2. Cutting tool is too small.</li> <li>3. Cutting tool getting too hot.</li> <li>4. Taking too big of a cut.</li> <li>5. Spindle extended too far down.</li> </ol>	<ol style="list-style-type: none"> <li>1. Set spindle speed correctly or use slower feed rate (<b>Page 37</b>).</li> <li>2. Use larger cutting tool and slower feed rate.</li> <li>3. Use coolant or oil for appropriate application.</li> <li>4. Lessen depth of cut and allow chips to clear.</li> <li>5. Fully retract spindle and raise table (<b>Pages 33 and 40</b>). This increases rigidity.</li> </ol>
Workpiece or tool vibrates or chatters during operation.	<ol style="list-style-type: none"> <li>1. Table locks not tight.</li> <li>2. Workpiece not secure.</li> <li>3. Spindle speed/feed rate is too fast.</li> <li>4. Spindle extended too far down.</li> <li>5. Quill lock lever not tight.</li> <li>6. Gibs too loose in table.</li> </ol>	<ol style="list-style-type: none"> <li>1. Tighten table locks (<b>Page 33</b>).</li> <li>2. Properly clamp workpiece on table or in vise.</li> <li>3. Set spindle speed correctly or use slower feed rate (<b>Page 37</b>).</li> <li>4. Fully retract spindle and raise table (<b>Pages 33 and 40</b>). This increases rigidity.</li> <li>5. Tighten quill lock lever (<b>Page 40</b>).</li> <li>6. Tighten gibs (<b>Page 57</b>).</li> </ol>
Table is hard to move.	<ol style="list-style-type: none"> <li>1. Table locks are tightened down.</li> <li>2. Chips have loaded up on ways.</li> <li>3. Ways are dry and need lubrication.</li> <li>4. Table limit stops are interfering.</li> <li>5. Gibs are too tight.</li> </ol>	<ol style="list-style-type: none"> <li>1. Fully release table locks (<b>Page 33</b>).</li> <li>2. Frequently clean away chips or debris.</li> <li>3. Lubricate ways (<b>Page 51</b>).</li> <li>4. Make sure that table limit stops are not in the way.</li> <li>5. Adjust gibs (<b>Page 57</b>).</li> </ol>
Headstock is hard to raise.	<ol style="list-style-type: none"> <li>1. Headstock lock(s) or gib is at fault.</li> <li>2. Headstock leadscrew is binding.</li> <li>3. Gib is too tight.</li> </ol>	<ol style="list-style-type: none"> <li>1. Loosen/replace lock lever and adjust gib (<b>Pages 40 and 57</b>).</li> <li>2. Clean and relubricate headstock leadscrew and gears (<b>Page 51</b>).</li> <li>3. Adjust gib (<b>Page 57</b>).</li> </ol>
Bad surface finish.	<ol style="list-style-type: none"> <li>1. Spindle speed/feed rate is too fast.</li> <li>2. Dull or incorrect cutting tool.</li> <li>3. Wrong rotation of cutting tool.</li> <li>4. Workpiece not secure.</li> <li>5. Spindle extended too far down.</li> </ol>	<ol style="list-style-type: none"> <li>1. Set spindle speed correctly or use slower feed rate (<b>Page 37</b>).</li> <li>2. Sharpen cutting tool or select one that better suits the operation.</li> <li>3. Check for proper cutting tool rotation.</li> <li>4. Properly clamp workpiece on table or in vise.</li> <li>5. Fully retract spindle and raise table (<b>Pages 33 and 40</b>). This increases rigidity.</li> </ol>
Cutting results not square.	<ol style="list-style-type: none"> <li>1. Table and spindle are not at 90° to each other.</li> <li>2. Table travel is inconsistent.</li> </ol>	<ol style="list-style-type: none"> <li>1. Tram the spindle (<b>Page 60</b>).</li> <li>2. Adjust gibs (<b>Page 57</b>).</li> </ol>
Spindle overheats.	<ol style="list-style-type: none"> <li>1. Poor spindle bearing lubrication.</li> <li>2. Spindle bearings too tight.</li> <li>3. Mill operated at high speeds for extended period.</li> </ol>	<ol style="list-style-type: none"> <li>1. Replace spindle bearings.</li> <li>2. Properly adjust spindle bearing preload.</li> <li>3. Allow mill to cool.</li> </ol>
Lack of power at spindle.	<ol style="list-style-type: none"> <li>1. Belts are loose.</li> <li>2. Wrong voltage.</li> </ol>	<ol style="list-style-type: none"> <li>1. Properly tension belts.</li> <li>2. Correct voltage.</li> </ol>
Spindle does not fully retract.	<ol style="list-style-type: none"> <li>1. Poorly adjusted return spring.</li> <li>2. Worn return spring.</li> </ol>	<ol style="list-style-type: none"> <li>1. Increase return spring tension.</li> <li>2. Replace return spring.</li> </ol>
Spindle switch does not work.	<ol style="list-style-type: none"> <li>1. Shorted/disconnected wiring.</li> </ol>	<ol style="list-style-type: none"> <li>1. Inspect wiring connections. Replace/repair as necessary.</li> </ol>



## Power Feed

Symptom	Possible Cause	Possible Solution
Powerfeed does not move table or is slipping.	<ol style="list-style-type: none"> <li>1. Table locked.</li> <li>2. Drive selector not engaged.</li> <li>3. Sheared pin.</li> <li>4. Gears not meshing or teeth missing.</li> <li>5. Motor shaft and gear shaft not engaged.</li> </ol>	<ol style="list-style-type: none"> <li>1. Unlock table locks.</li> <li>2. Select speed, engage drive selector.</li> <li>3. Replace pin.</li> <li>4. Check gears and adjust/replace.</li> <li>5. Replace clutch.</li> </ol>
Operates at high speed only or is inconsistent.	<ol style="list-style-type: none"> <li>1. Rapid micro switch is stuck.</li> <li>2. V.R. does not work properly.</li> <li>3. Wiring harness unplugged from circuit board.</li> </ol>	<ol style="list-style-type: none"> <li>1. Lightly tap on it to lower it.</li> <li>2. Test/repair/replace.</li> <li>3. Reconnect wiring harness.</li> </ol>

## Lamp

Symptom	Possible Cause	Possible Solution
Lamp will not light.	<ol style="list-style-type: none"> <li>1. Power not turned on.</li> <li>2. Bulb is burned out.</li> <li>3. Short in wiring or wired incorrectly.</li> </ol>	<ol style="list-style-type: none"> <li>1. Press switch/button on lamp or control panel.</li> <li>2. Replace bulb.</li> <li>3. Trace and test wiring. Fix any errors.</li> </ol>

## Digital Readout Unit (DRO)

Symptom	Possible Cause	Possible Solution
DRO does not give reading.	<ol style="list-style-type: none"> <li>1. DRO is not turned on/plugged in.</li> <li>2. Shorted/disconnected wiring/plugs.</li> </ol>	<ol style="list-style-type: none"> <li>1. Press DRO ON/Power button/plug in.</li> <li>2. Inspect circuit boards, sensors, plugs, and wiring connections. Replace/repair as necessary.</li> </ol>
DRO reading is incorrect.	<ol style="list-style-type: none"> <li>1. Initial reading is incorrect.</li> <li>2. Sensor has gone bad.</li> <li>3. Spacing between sensor and scale is incorrect.</li> </ol>	<ol style="list-style-type: none"> <li>1. Tare/zero/reset DRO at beginning point.</li> <li>2. Test/replace sensor as necessary.</li> <li>3. Adjust spacing between sensor and scale.</li> </ol>



# Adjusting Gibs

Gibs are tapered lengths of metal that are sandwiched between two moving surfaces. Gibs control the gap between these surfaces and how they slide past one another. Correctly adjusting the gibs is critical to producing good milling results.

Tight gibs make table movement more accurate but stiff. Loose gibs make moving the table sloppy but easier to do. The goal of gib adjustment is to remove unnecessary sloppiness without causing the ways to bind.

Gibs are adjusted with a screw on each end of the gib, that move the tapered gib back-and-forth to increase or decrease the friction pressure between the sliding surfaces. The process of properly adjusting the gibs requires trial-and-error and patience.

Refer to **Figures 79–81** to identify the locations of the table, saddle, and knee gibs, and one of the two adjustment screws for each.

**Note:** *It will be necessary to remove small parts, such as way wipers and covers, to access the gib adjustment screws.*

Tools Needed	Qty
Screwdriver Phillips, Flat Head.....	1 Ea

## To adjust gibs:

1. DISCONNECT MACHINE FROM POWER!
2. Make sure all table/knee locks are loose.
3. Loosen one gib adjustment screw, then tighten the other the same amount to move the gib.
4. Use ball handles/crank to move table/knee until you feel a slight drag in the path of movement. Repeat **Steps 3–4** as necessary.



**Figure 79.** Table gib and adjustment screw underneath left side of table.

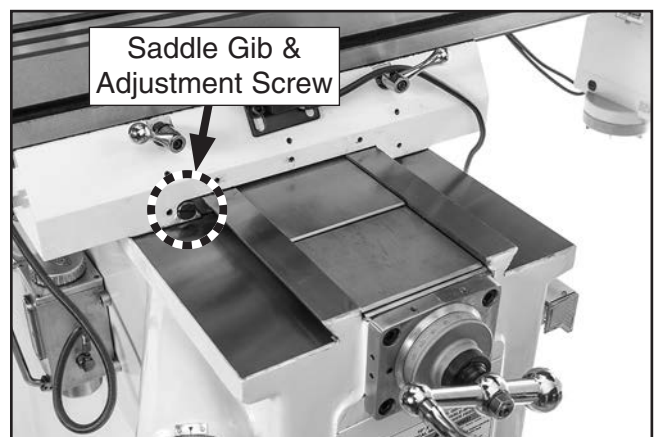

**Figure 80.** Saddle gib and adjustment screw.



**Figure 81.** Knee gib and adjustment screw.



# Adjusting Leadscrew Backlash

Leadscrew backlash is the amount of motion or "play" in leadscrew rotation before the attached device begins to move. Leadscrews will always have a certain amount of backlash that will increase with normal wear.

Generally, 0.005"–0.010" leadscrew backlash is acceptable to ensure smooth movement and reduce the risk of premature thread wear. However, if you find it necessary to adjust leadscrew backlash, perform the procedures listed below.

Tools Needed	Qty
T-Handle Hex Wrench 5mm.....	1
Hex Wrench 3mm.....	2
Hex Wrench 8mm.....	1
Wrench 19mm.....	1

## X-Axis Leadscrew Backlash

1. DISCONNECT MILL FROM POWER!
2. Loosen two cap screws on X-axis leadscrew nut accessed from underneath left side of table (see **Figure 82**).
3. Rotate adjustment plate on leadscrew nut (see **Figure 82**) in small increments, then check amount of backlash.

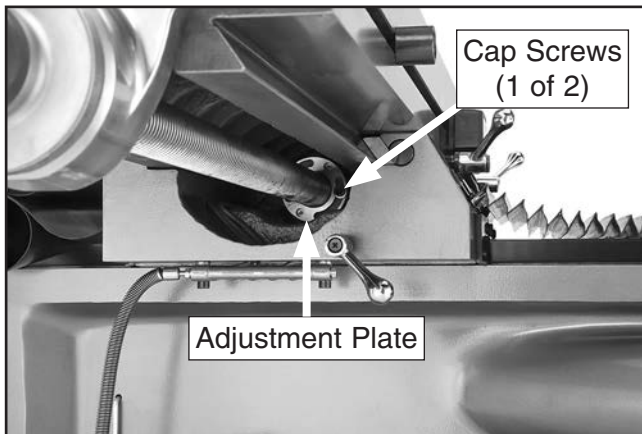

**Figure 82.** X-axis leadscrew nut cap screws and adjustment plate (viewed from underneath left side of table).

4. When you are satisfied with adjustment, retighten two cap screws.

## Cross Leadscrew Backlash

1. DISCONNECT MACHINE FROM POWER!
2. Remove hex nut and ball handle from Y-axis leadscrew (see **Figure 83**).

**Note:** *In the next step, take care not to misplace the leadscrew key as you remove the parts.*

3. Unthread and remove knurled retaining ring, graduated dial ring, and leadscrew key (see **Figure 83**).



**Figure 83.** Ball handle, ring, and key removed from Y-axis leadscrew.

4. Remove four cap screws from bearing housing, then slide it off leadscrew (see **Figure 84**).

**Note:** *It may be necessary to use a dead blow hammer or rubber mallet on the housing to knock it loose.*

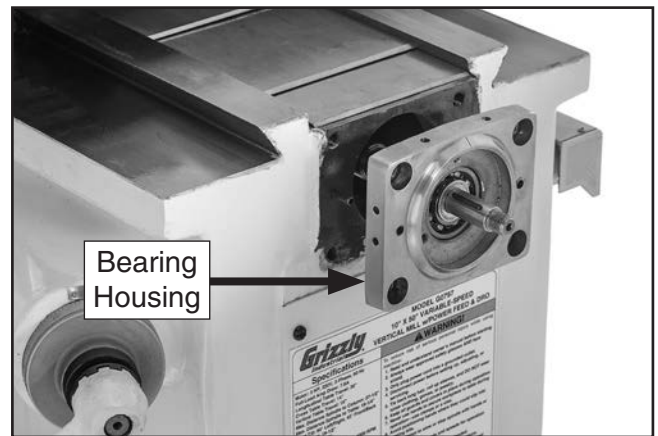

**Figure 84.** Y-axis bearing housing.



5. Loosen two cap screws on face of leadscrew nut shown in **Figure 85**.



**Figure 85.** Y-axis leadscrew nut and cap screws.

6. Re-install key back onto leadscrew so that you can use ball handle in next step.
7. Rotate adjustment plate on leadscrew nut in small increments, slide ball handle onto leadscrew, then check amount of backlash.
8. When you are satisfied with adjustment, re-tighten two cap screws.
9. Re-install parts previously removed in reverse order.



# Tramming Spindle

After positioning the head at an angle and when your operation requires that the spindle axis be precisely perpendicular to the table, you must tram or align the spindle with the table to ensure the spindle is exactly 90° to the table.

This procedure involves mounting a dial test indicator to the quill or spindle, rotating it around the table, and adjusting the spindle axis (Z-axis) 90° to the table X- and Y-axis, as illustrated in **Figure 86**.

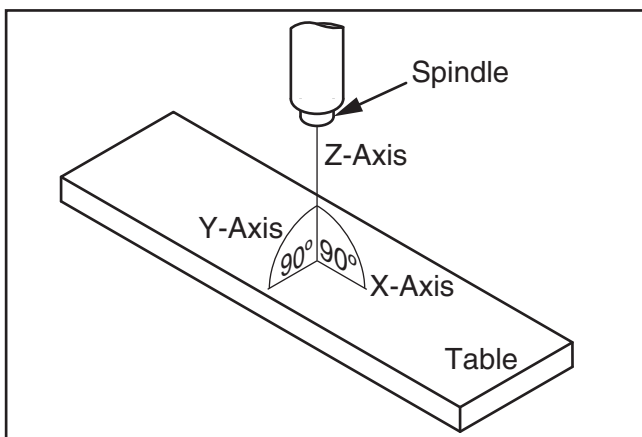

**Figure 86.** Spindle Z-axis perpendicular to the table X- and Y-axis.

We encourage you to research the many variations of spindle tramming to find the one that works best for you. If you do not already have a preference for performing this operation, use the following widely-used procedure for accurately tramming the spindle to the table.

Keep in mind that all workpiece top surfaces are not exactly parallel with the table top. You may choose to tram the spindle to the top surface of the workpiece after it is mounted rather than tramming the spindle to the table.

<b>Tools Needed</b>	<b>Qty</b>
Dial Test Indicator (with at least 0.0005" resolution) .....	1
Indicator Holder (mounted on the quill/spindle) .....	1
Precision Parallel Block (at least 9" in length).....	1

**Note:** A precision-ground plate can be substituted for the parallel blocks. Keep in mind that the farther the indicator point can be placed from the spindle axis, the more accurate the alignment measurements will be.

## To tram spindle to table:

1. DISCONNECT MACHINE FROM POWER!
2. Prepare mill for tramming by performing following tasks:
  - Verify the table is clean by running your hand over the top of it. If necessary, stone the table to remove all nicks and burrs, then clean off all debris.
  - Position the table for the milling operation you intend to perform after tramming—preferably centered with the saddle.
  - Tighten any table, knee, quill, or ram locks that should be tight during the intended milling operation.
3. Place parallel block underneath spindle.
4. Install indicator holder in spindle or on quill, then mount indicator so that point is as parallel to block as possible (see **Figure 87**).

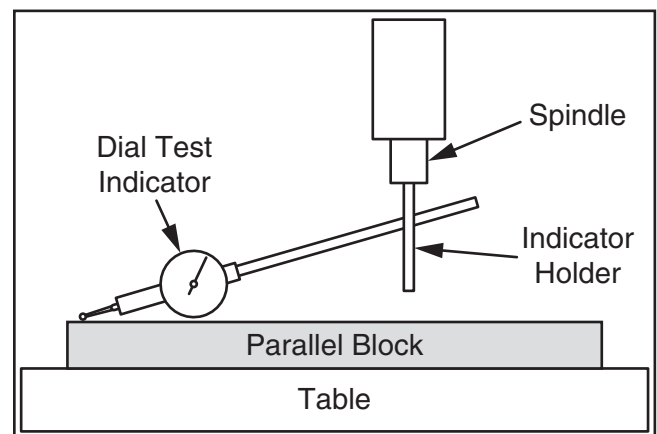
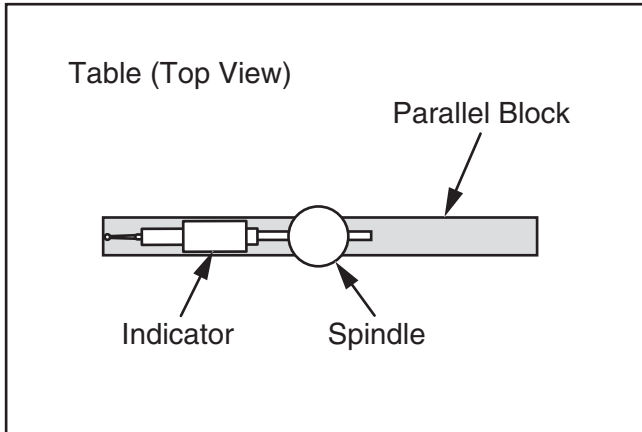

**Figure 87.** Dial test indicator mounted.



- To measure spindle alignment along X-axis, place parallel block directly under spindle and indicator across length of table, as illustrated in **Figure 88**.

**Note:** If you must re-position the quill or the knee to accommodate the above step, then review the tasks in **Step 2** to make sure the mill is properly prepared for tramping.



**Figure 88.** Parallel block and indicator positioned for the X-axis measurement (top view).

**Note:** Your general goal in the next steps should be to get the difference of the indicator readings between the ends of the parallel bar down to 0.0005". However, the acceptable variance will depend on the requirements for your operation.

- Rotate spindle by hand so that indicator point rests on one end of parallel block, as illustrated in **Figures 87–88**, then zero the dial.
- Rotate spindle so that indicator point rests in same manner on other end of block, then read dial.
  - If the indicator dial still reads zero or is within the acceptable variance, continue on with **Step 8**.
  - If the indicator dial has moved from zero beyond the acceptable variance, you will need to compensate for that amount by rotating the head left or right. Repeat **Steps 6–7** until you are satisfied with the spindle axis alignment along the table X-axis.

**Note:** Keep one of the rotation lock bolts just snug so the head does not move loosely while you adjust it. Remember to tighten all the rotation lock bolts after adjusting the head.

- Place parallel block directly under spindle and across width of table, as illustrated in **Figure 89**.

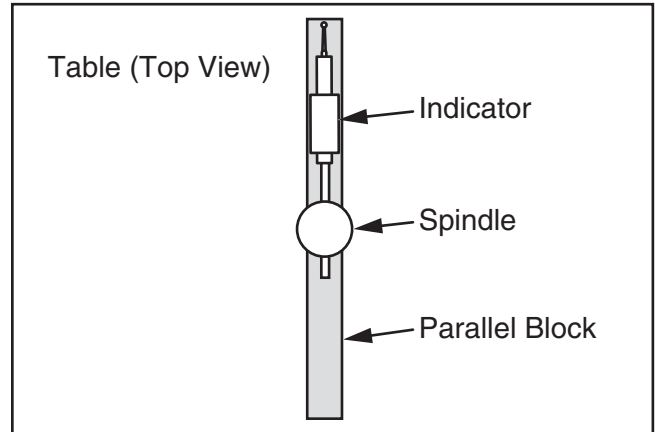

**Figure 89.** Parallel block and indicator positioned for the Y-axis measurement (top view).

- Rotate spindle so indicator point rests on parallel bar, as illustrated in **Figure 89**, then zero the dial.
- Rotate spindle so that indicator point rests on other end of bar in same manner, then read dial.

— If the indicator dial still reads zero or is within the acceptable variance, the spindle is precisely perpendicular to the table in both the X- and Y-axis, and the tramping procedure is complete.

— If the indicator dial has moved from zero beyond the acceptable variance, you will need to compensate for that amount by tilting the head forward or backward. Repeat **Steps 9–10** until you are satisfied with the spindle axis alignment along the table Y-axis.

**Note:** Keep one of the tilt lock bolts just snug so the head does not move loosely while you adjust it. Remember to tighten all the tilt lock bolts after adjusting the head.



# Replacing Belts & Brake Shoes

Replacing a broken belt or the spindle brake shoes requires removing the motor and part of the headstock. These components are very heavy, and you will need the assistance of a helper to remove them.

Since the procedure for replacing the spindle brake shoes involves removing many of these same components as in a belt replacement, it is a good idea to check the brake shoes whenever you replace a belt, and replace the shoes if necessary.

## G0796

Tools Needed	Qty
Screwdriver Phillips #2 .....	1
Hex Wrench 5mm.....	1
Wrench 17mm.....	1
External Retaining Ring Pliers .....	1

### To replace belts or brake shoes:

1. DISCONNECT MACHINE FROM POWER!
2. Remove drawbar (see **Page 44**).
3. Remove V-belt (if broken).
4. Remove (2) motor mount cap screws, then remove motor (see **Figure 90**).

**Note:** If V-belt is not broken, be sure to carefully remove it from motor pulley before lifting motor off of headstock.

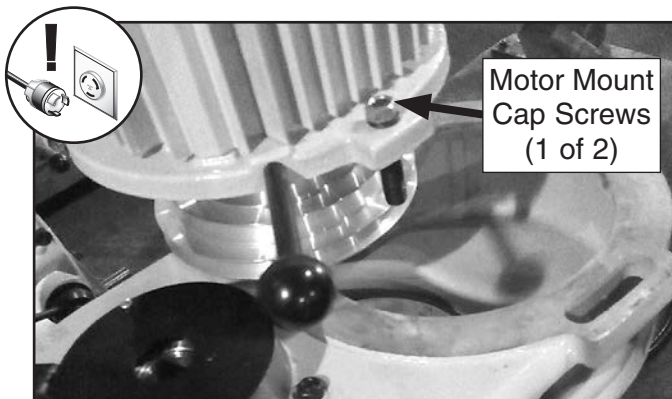

**Figure 90.** Two cap screws secure the motor to the headstock. Both must be removed.

5. Remove (2) Phillips head screws shown in **Figure 91**, then remove bearing cover from top of headstock.

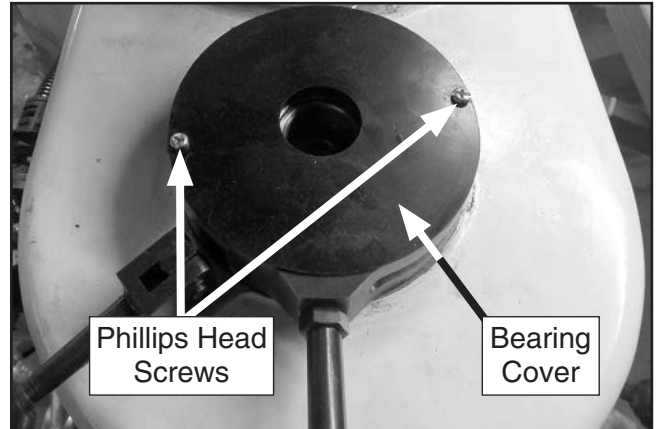

**Figure 91.** Location of G0796 bearing cover and Phillips head screws removed during belt/brake shoe replacement procedure.

6. Remove set screw from each side of cam ring, then remove cam ring with attached lever (see **Figure 92**).

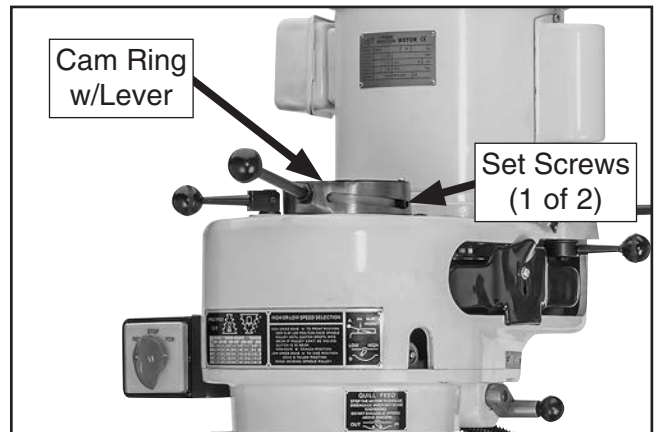

**Figure 92.** Once set screws are removed, cam ring and lever can be lifted off.





- Remove (3) hex nuts with washers that secure upper housing to quill housing (see **Figure 93**).

**Note:** The upper housing is composed of the gear housing and the belt housing, which you will separate in **Step 9**.

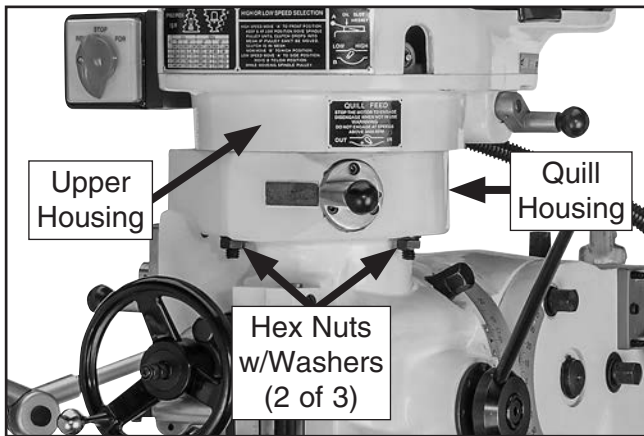

**Figure 93.** Location of hex nuts and washers that secure upper housing to quill housing.

- With upper housing removed (see **Figure 94**), you can now separate gear housing from belt housing.

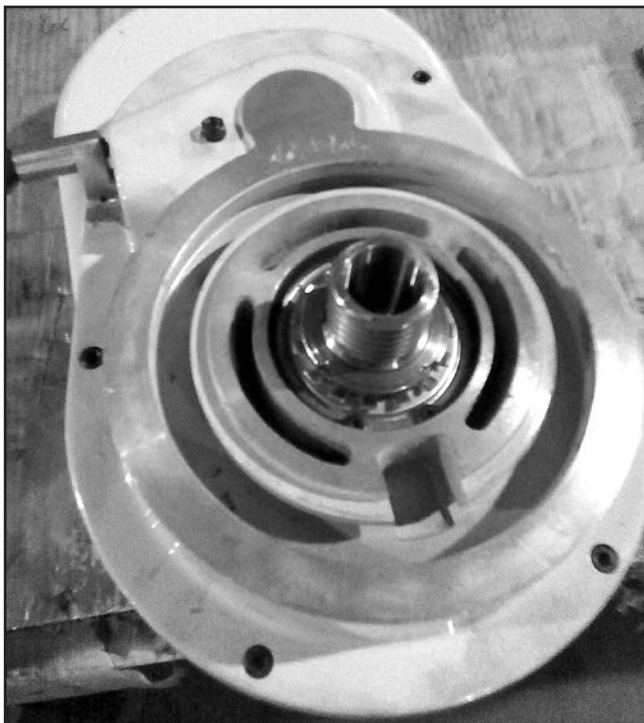

**Figure 94.** Belt housing placed upside down on workbench.

- Use a 5mm hex wrench to remove gear housing from belt housing (see **Figure 95**).

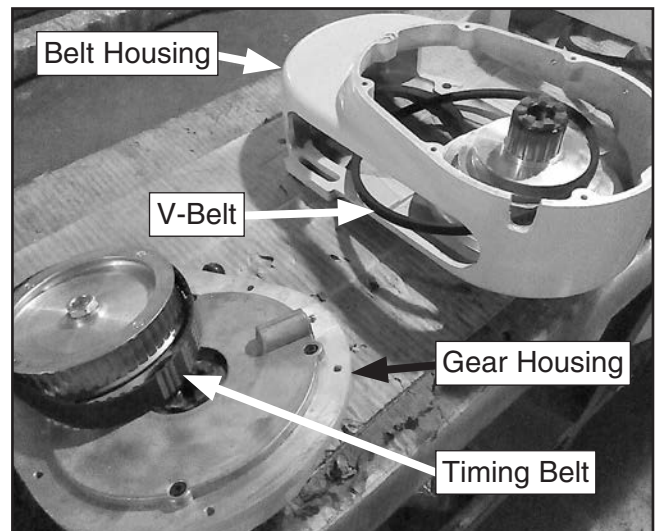

**Figure 95.** Once gear housing is separated from belt housing, both belts can be accessed.

- Inspect both belts for damage or wear. Replace if necessary.
- Slide motor pulley up to remove it from belt housing (see **Figure 96**), inspect brake shoes for damage or wear, and replace if necessary.

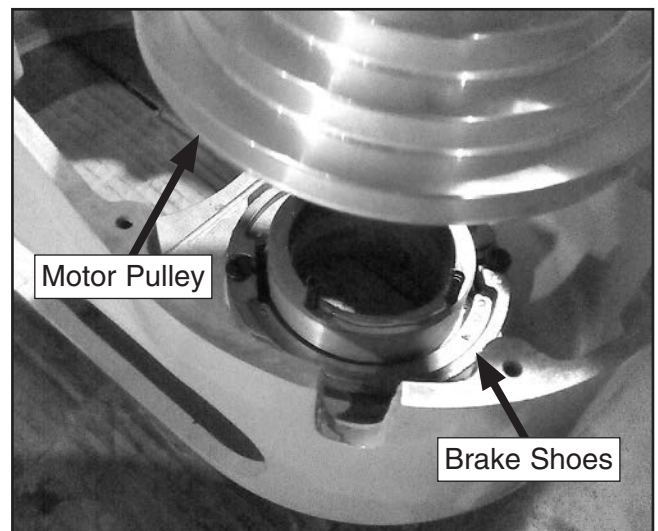

**Figure 96.** Removing motor pulley to gain access to brake shoes.

- Re-assemble machine in reverse order from **Steps 2–11**.



## G0797

### Tools Needed

	Qty
Screwdriver Phillips #2 .....	1
Hex Wrench 5mm.....	1
Wrench 17mm.....	1
External Retaining Ring Pliers .....	1

### To replace belts or brake shoes:

### To replace belts or brake shoes (G0797):

1. DISCONNECT MACHINE FROM POWER!
2. Remove drawbar (see **Page 44**).
3. Remove (4) motor mount cap screws, then remove motor (see **Figure 97**).
4. Remove headstock side cover (see **Figure 97**) and drive belt.

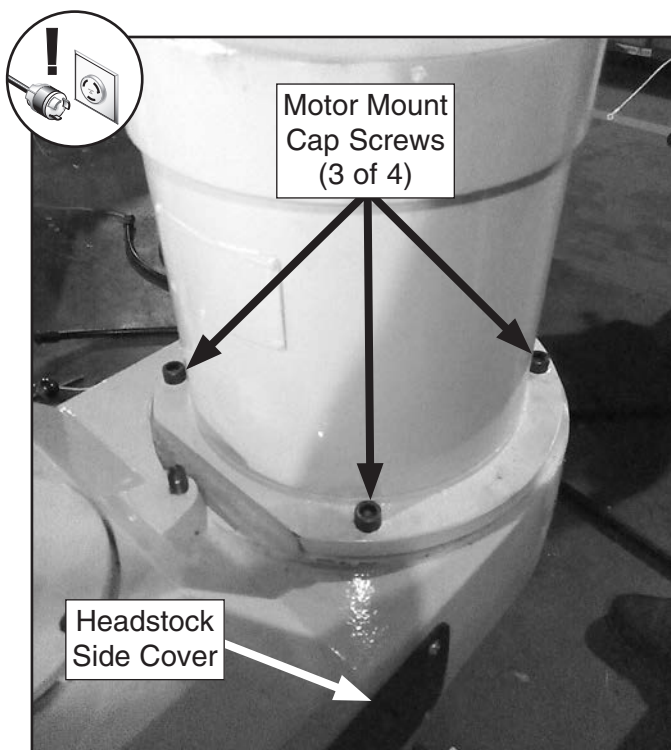
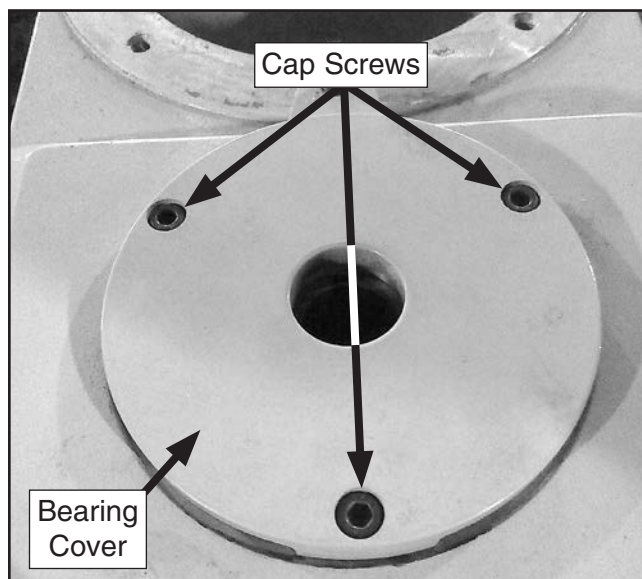

**Figure 97.** Location of G0797 motor mount cap screws and headstock side cover.

— If replacing drive belt, install new belt using headstock side cover opening for access to guide new belt onto motor pulley as you position motor for re-installation, then re-install motor with new belt installed.

— If replacing timing belt or brake shoes, proceed to **Step 5**.

5. Remove (3) cap screws from spindle bearing cover (see **Figure 98**).



**Figure 98.** Spindle bearing cover located on top of headstock.

6. Pry off spindle bearing cover (see **Figure 99**).

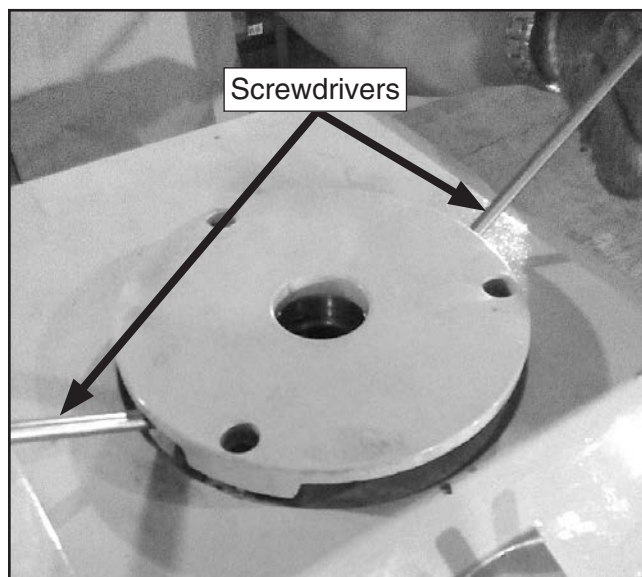

**Figure 99.** Using two flat head screwdrivers to remove spindle bearing cover.



- Remove (2) cap screws with flat washers from speed changer plate, located above spindle (see **Figure 100**).

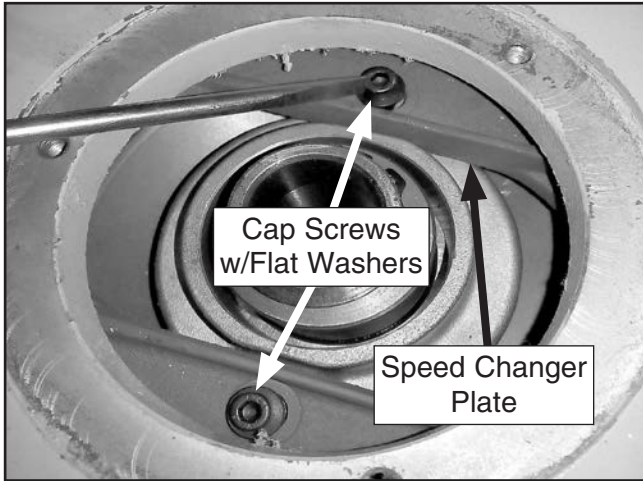

**Figure 100.** Cap screws must be removed from speed changer plate before disassembling headstock.

- Remove (3) hex bolts shown in **Figure 101**, then remove headstock from spindle housing and place upside down on workbench.

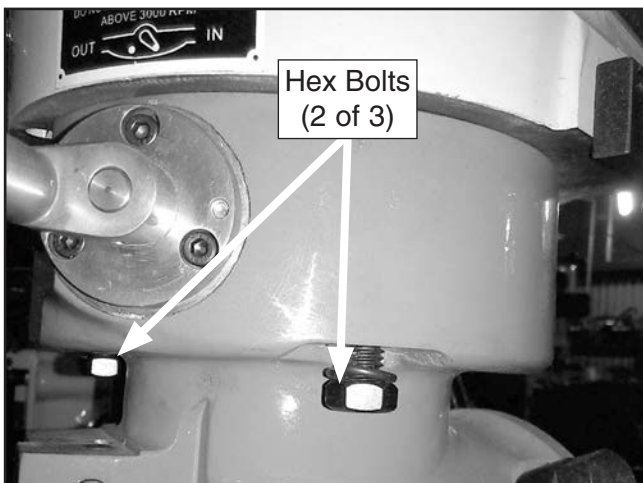

**Figure 101.** Location of hex bolts that secure headstock to spindle housing.

- Remove headstock bottom cover from headstock upper casting, then loosen (4) cap screws and remove brake bracket/pulley assembly (see **Figure 102**). This will provide access for replacing timing belt.

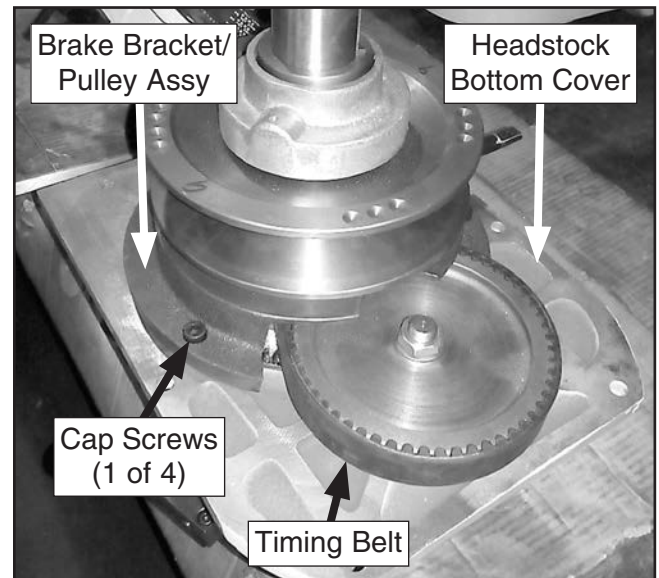

**Figure 102.** G0797 headstock bottom cover removed to expose brake bracket.

- Remove external retaining ring and bearing cover assembly from brake bracket/pulley assembly (see **Figure 103**), then remove upper pulley.

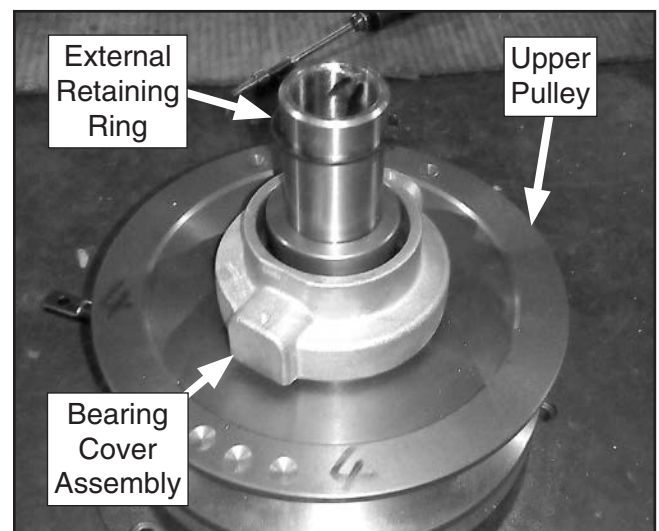

**Figure 103.** Brake bracket and pulley components removed for disassembly.



11. Remove external retaining ring that secures lower pulley to shaft (see **Figure 104**).

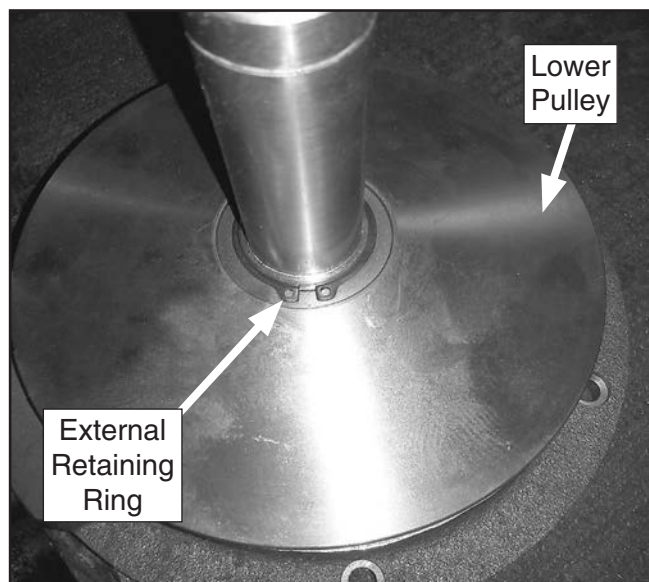

**Figure 104.** Upper pulley removed to expose retaining ring and lower pulley.

12. Use a press to remove shaft and bearing sleeve assembly from pulley and brake bracket (see **Figure 105**).

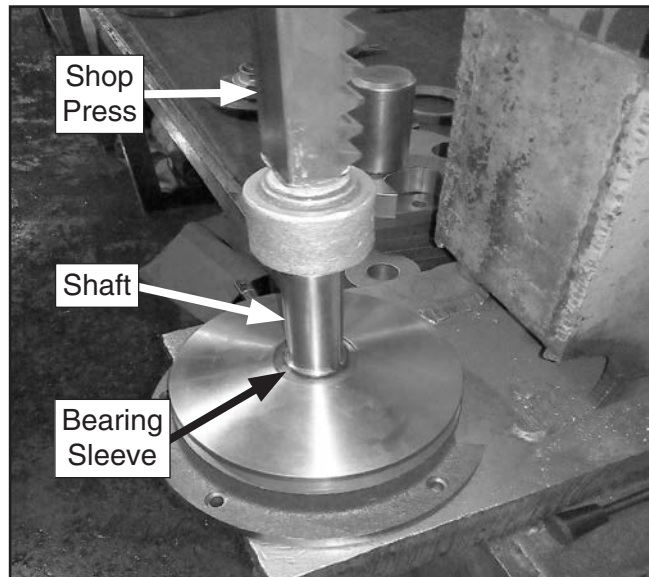

**Figure 105.** Brake bracket mounted on shop press for removal of shaft, bearing sleeve, and lower pulley.

13. Remove and replace brake shoes (see **Figure 106**).



**Figure 106.** Lower pulley, shaft, and bearing sleeve removed to expose brake shoes for inspection/replacement.

14. Use press to re-install shaft and bearing sleeve assembly into brake bracket and lower pulley (see **Figure 107**).

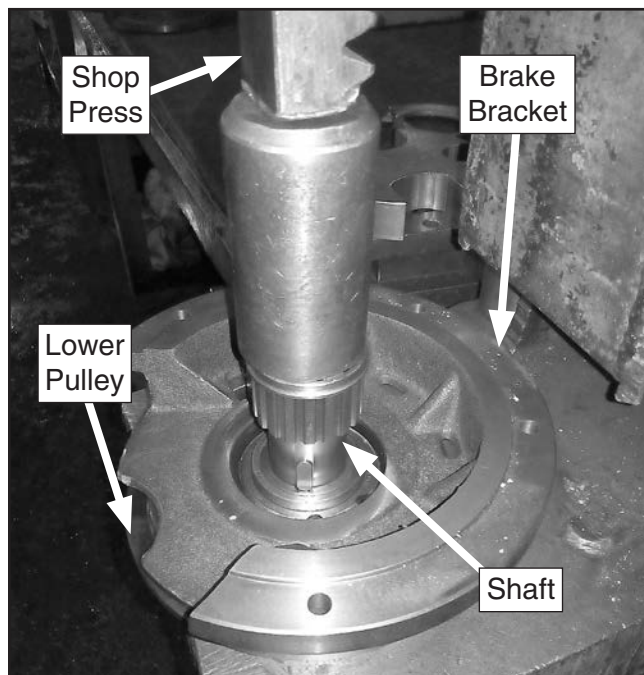

**Figure 107.** Using shop press to re-install shaft with bearing assembly into brake bracket and lower pulley.

15. Re-assemble head in reverse order from **Steps 2–11**.



# SECTION 8: WIRING

These pages are current at the time of printing. However, in the spirit of improvement, we may make changes to the electrical systems of future machines. Compare the manufacture date of your machine to the one stated in this manual, and study this section carefully.

If there are differences between your machine and what is shown in this section, call Technical Support at (570) 546-9663 for assistance BEFORE making any changes to the wiring on your machine. An updated wiring diagram may be available. **Note:** *Please gather the serial number and manufacture date of your machine before calling. This information can be found on the main machine label.*

## WARNING

### Wiring Safety Instructions

**SHOCK HAZARD.** Working on wiring that is connected to a power source is extremely dangerous. Touching electrified parts will result in personal injury including but not limited to severe burns, electrocution, or death. Disconnect the power from the machine before servicing electrical components!

**MODIFICATIONS.** Modifying the wiring beyond what is shown in the diagram may lead to unpredictable results, including serious injury or fire. This includes the installation of unapproved after-market parts.

**WIRE CONNECTIONS.** All connections must be tight to prevent wires from loosening during machine operation. Double-check all wires disconnected or connected during any wiring task to ensure tight connections.

**CIRCUIT REQUIREMENTS.** You MUST follow the requirements at the beginning of this manual when connecting your machine to a power source.

**WIRE/COMPONENT DAMAGE.** Damaged wires or components increase the risk of serious personal injury, fire, or machine damage. If you notice that any wires or components are damaged while performing a wiring task, replace those wires or components.

**MOTOR WIRING.** The motor wiring shown in these diagrams is current at the time of printing but may not match your machine. If you find this to be the case, use the wiring diagram inside the motor junction box.













**CAPACITORS/INVERTERS.** Some capacitors and power inverters store an electrical charge for up to 10 minutes after being disconnected from the power source. To reduce the risk of being shocked, wait at least this long before working on capacitors.

**EXPERIENCING DIFFICULTIES.** If you are experiencing difficulties understanding the information included in this section, contact our Technical Support at (570) 546-9663.

#### NOTICE

The photos and diagrams included in this section are best viewed in color. You can view these pages in color at [www.grizzly.com](http://www.grizzly.com).

#### COLOR KEY

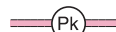
BLACK 	BLUE 	YELLOW 	LIGHT BLUE 
WHITE 	BROWN 	YELLOW GREEN 	BLUE WHITE 
GREEN 	GRAY 	PURPLE 	TURQUOISE 
RED 	ORANGE 	PINK 	



# G0796 Motor & Switch Wiring

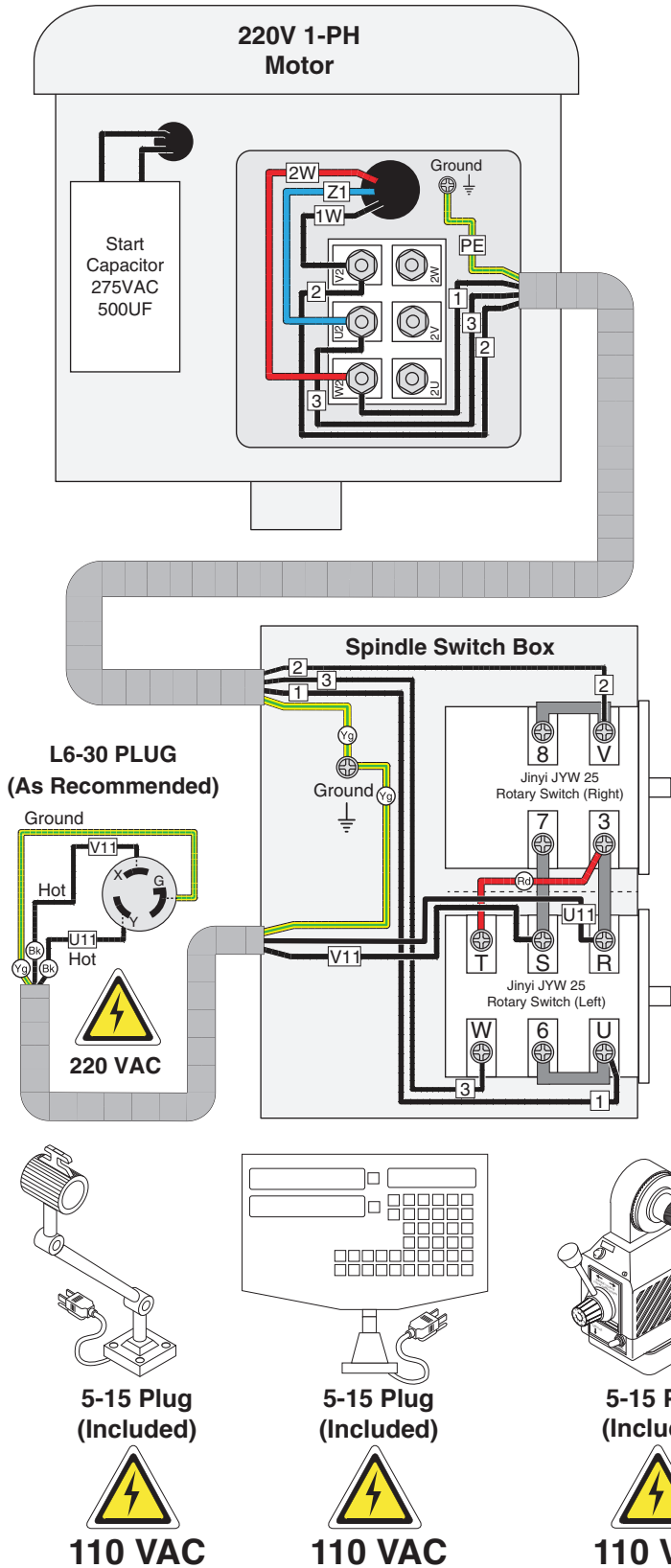

Figure 108. G0796 motor wiring.



Figure 109. Run and start capacitors.

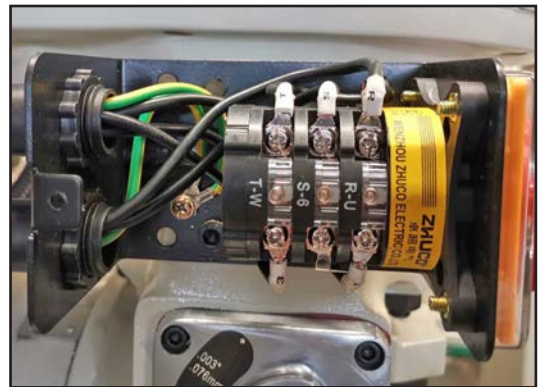

Figure 110. Spindle switch.



# G0797 Motor & Switch Wiring (220V)

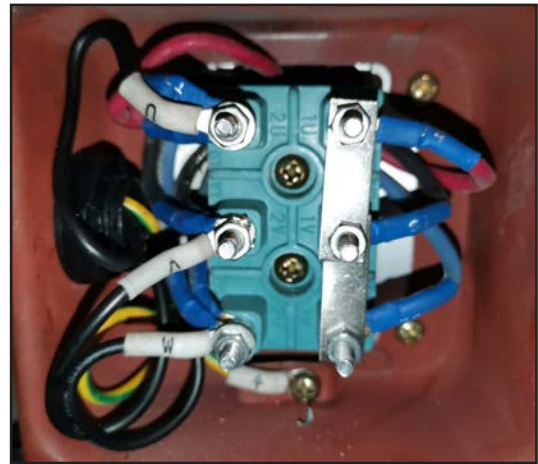
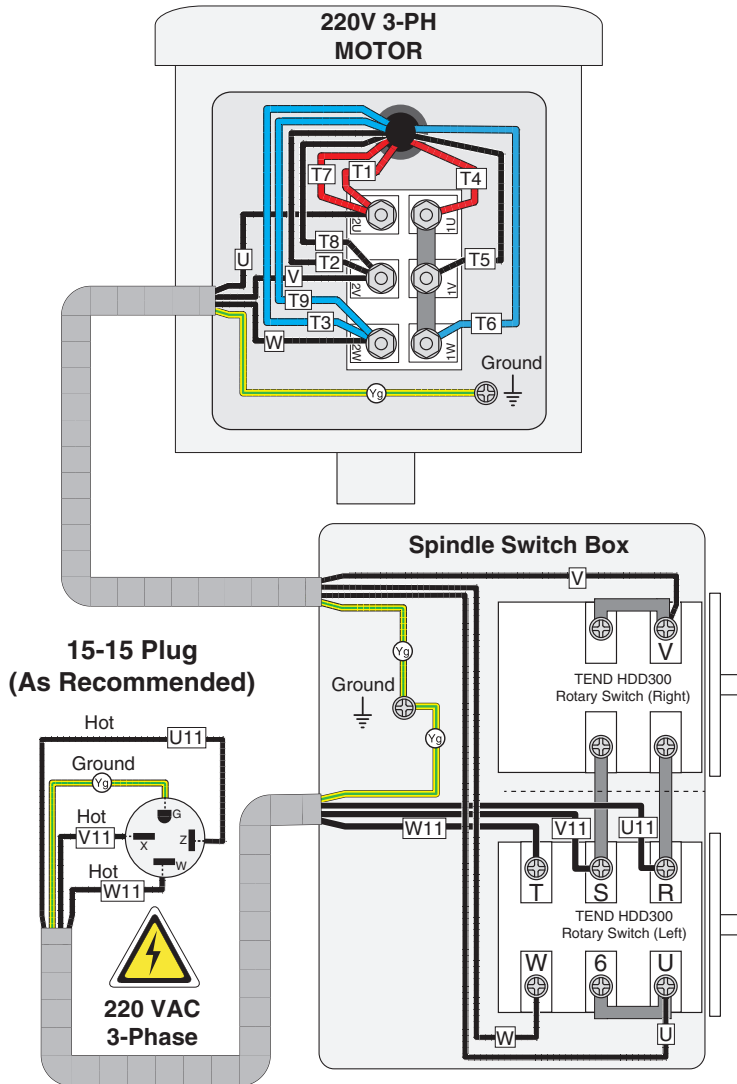
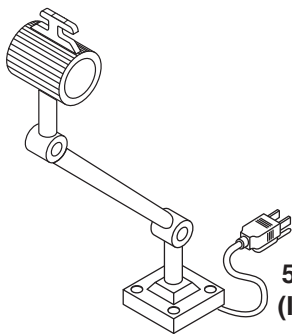

Figure 111. G0797 motor wiring (220V).

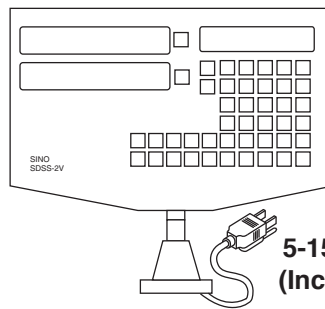

Figure 112. Spindle switch.



5-15 Plug (Included)

110 VAC



5-15 Plug (Included)

110 VAC

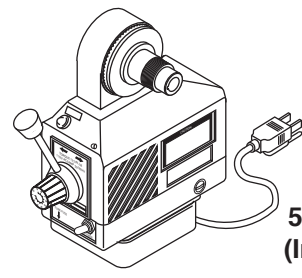

5-15 Plug (Included)

110 VAC



# G0797 Motor & Switch Wiring (440V)

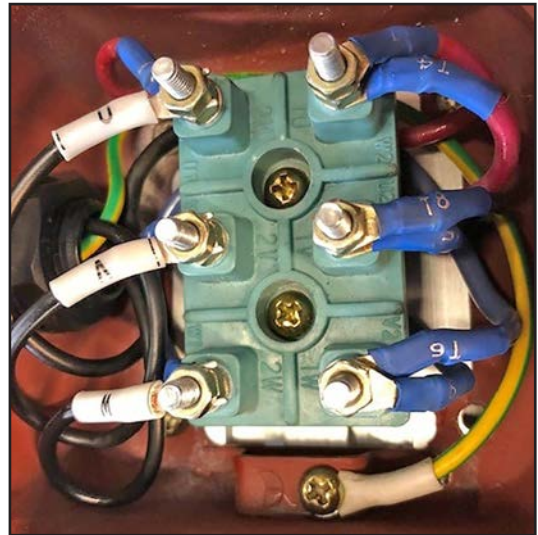
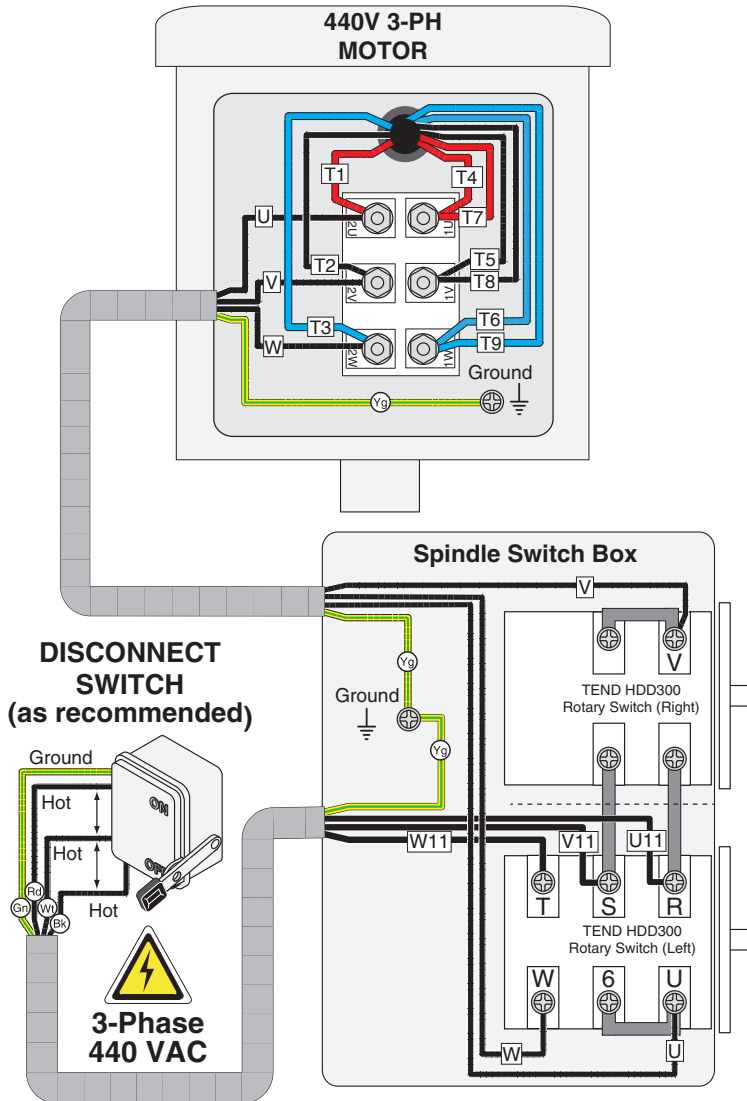

Figure 113. G0797 motor wiring (440V).

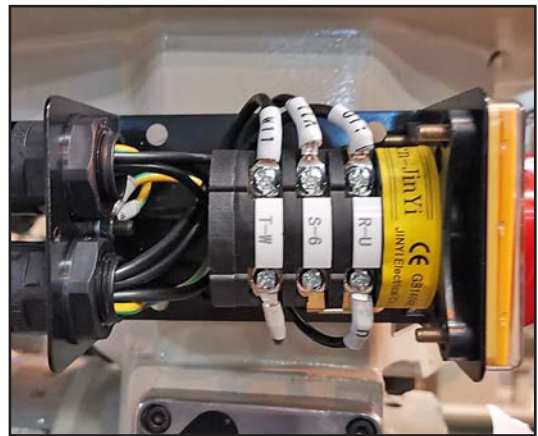
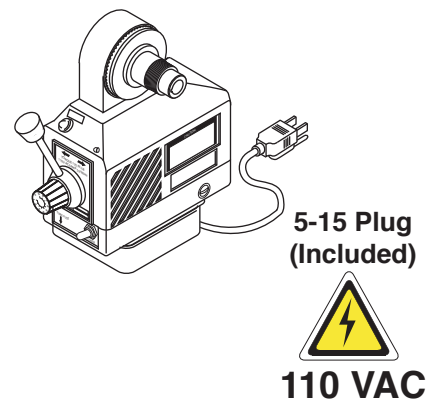
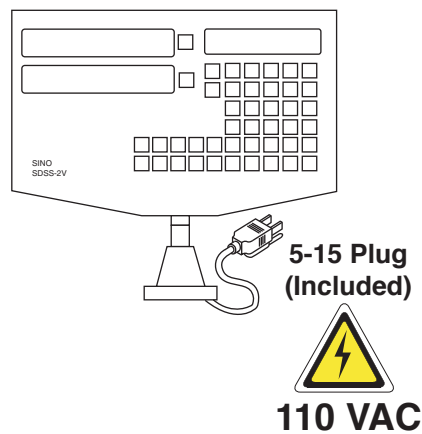
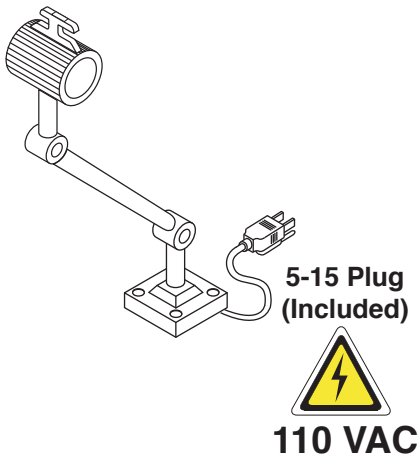

Figure 114. Spindle switch.





# SECTION 9: PARTS

We do our best to stock replacement parts when possible, but we cannot guarantee that all parts shown are available for purchase. Call (800) 523-4777 or visit [www.grizzly.com/parts](http://www.grizzly.com/parts) to check for availability.

## G0796 Main Body

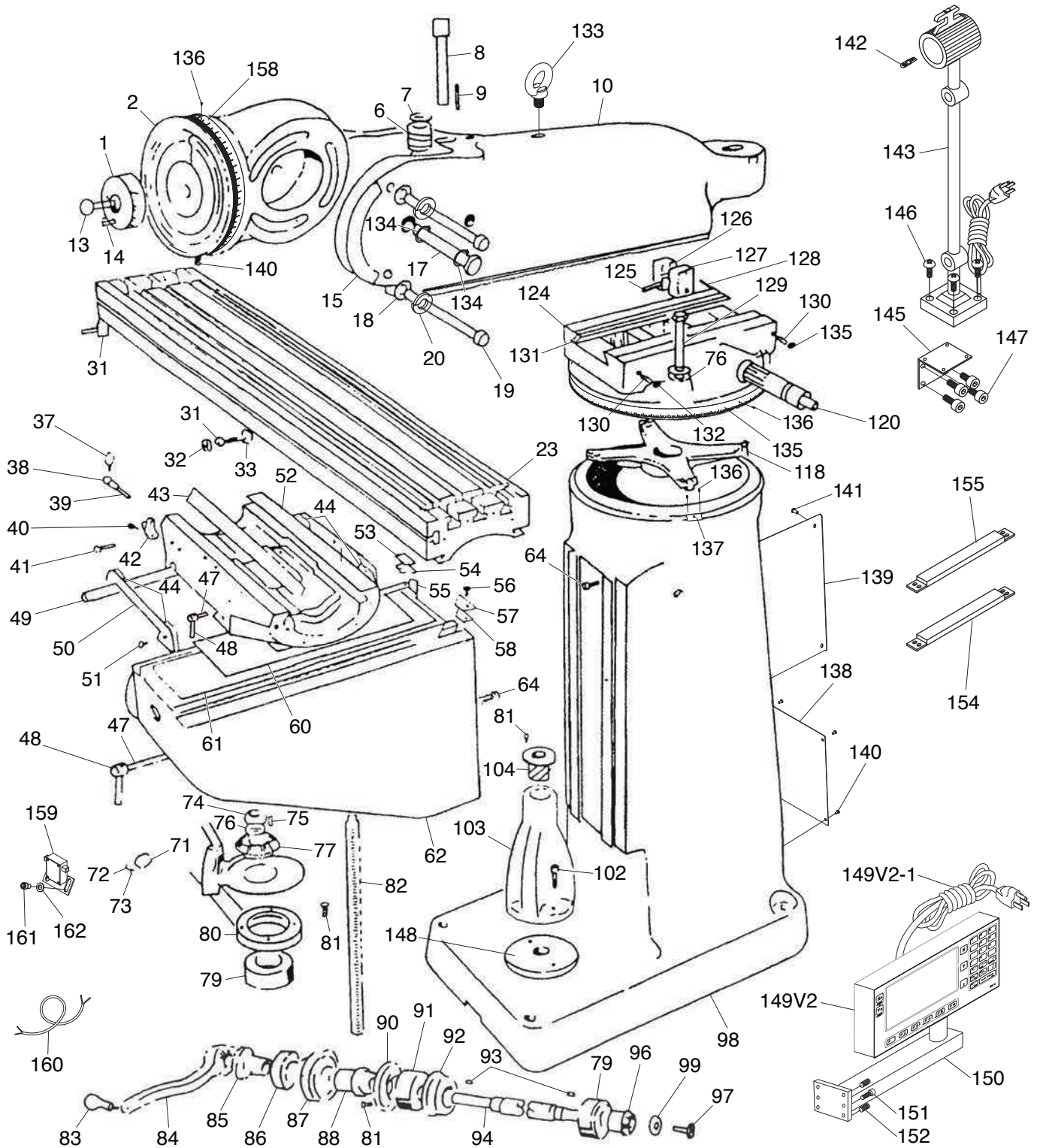

# G0796 Main Body Parts List

REF	PART #	DESCRIPTION
1	P0796001	QUILL HOUSING ADJUSTMENT GEAR 46T
2	P0796002	RAM ADAPTER
6	P0796006	HEAD TILT ADJUSTING WORM
7	P0796007	WORM THRUST WASHER 8MM
8	P0796008	HEAD TILT ADJUSTING WORM SHAFT
9	P0796009	KEY 5 X 5 X 50
10	P0796010	RAM CASTING
13	P0796013	CAP SCREW M6-1 X 25
14	P0796014	ROLL PIN 8 X 30
15	P0796015	HEAD TILT SCALE
17	P0796017	ADAPTER PIVOT SHAFT 28 X 190
18	P0796018	FLAT WASHER 12MM
19	P0796019	HEX BOLT M12-1.75 X 190
20	P0796020	LOCK WASHER 12MM
23	P0796023	TABLE 9" X 49"
31	P0796031	CAP SCREW M8-1.25 X 35
32	P0796032	LIMIT STOP
33	P0796033	SQUARE NUT M8-1.25
37	P0796037	SADDLE LOCK BOLT HANDLE
38	P0796038	SADDLE LOCK BOLT M12-1.75 X 25
39	P0796039	SADDLE LOCK BOLT PLUNGER
40	P0796040	CAP SCREW 3/8-16 X 3/4
41	P0796041	GIB ADJUSTING SCREW 3/8-16 X 3/4
42	P0796042	TABLE STOP BRACKET
43	P0796043	TABLE GIB
44	P0796044	SADDLE WAY WIPER
47	P0796047	TABLE LOCK BOLT M12-1.75 X 25
48	P0796048	ADJUSTABLE HANDLE ASSY
49	P0796049	SADDLE GIB
50	P0796050	SADDLE WIPER HOLDER
51	P0796051	PHLP HD SCR 10-24 X 1/2
52	P0796052	SADDLE CASTING
53	P0796053	COLUMN WAY WIPER HOLDER (LEFT)
54	P0796054	COLUMN WAY WIPER (LEFT)
55	P0796055	KNEE GIB
56	P0796056	CAP SCREW M6-1 X 12
57	P0796057	COLUMN WAY WIPER HOLDER (RIGHT)
58	P0796058	COLUMN WAY WIPER (RIGHT)
60	P0796060	UPPER SADDLE COVER
61	P0796061	LOWER SADDLE COVER
62	P0796062	KNEE CASTING
64	P0796064	KNEE STOP BOLT
71	P0796071	KNEE PLUG (PLASTIC)
72	P0796072	SET SCREW 10-24 X 1/2 DOG-PT
73	P0796073	SET SCREW 10-24 X 1/2
74	P0796074	HEX NUT 1/2-20
75	P0796075	KEY 5 X 5 X 20
76	P0796076	FLAT WASHER 1/2
77	P0796077	Z-AXIS BEVEL GEAR 27T
79	P0796079	BALL BEARING 6207ZZ
80	P0796080	BEARING RETAINER RING
81	P0796081	CAP SCREW M6-1 X 20
82	P0796082	Z-AXIS LEADSCREW
83	P0796083	CRANK HANDLE
84	P0796084	Z-AXIS CRANK ARM

REF	PART #	DESCRIPTION
85	P0796085	CLUTCH
86	P0796086	DIAL LOCK NUT
87	P0796087	GRADUATED DIAL 0.001"/0.100"
88	P0796088	DIAL HOLDER
90	P0796090	BEARING RETAINER RING
91	P0796091	BALL BEARING 6204ZZ
92	P0796092	BEARING CAP
93	P0796093	KEY 3 X 3 X 18
94	P0796094	Z-AXIS SHAFT
96	P0796096	BEVELED PINION GEAR 32T
97	P0796097	SET SCREW M6-1 X 6
98	P0796098	COLUMN CASTING
99	P0796099	FLAT WASHER 3/4
102	P0796102	CAP SCREW M10-1.5 X 25
103	P0796103	Z-AXIS PEDESTAL
104	P0796104	Z-AXIS LEADSCREW NUT
118	P0796118	RAM SWIVEL
120	P0796120	RAM PINION
124	P0796124	TURRET
125	P0796125	RAM CLAMP BAR
126	P0796126	UNTAPPED RAM CLAMP
127	P0796127	TAPPED RAM CLAMP
128	P0796128	ROLL PIN 10 X 20
129	P0796129	RAM LOCK BOLT M12-1.75 X 250
130	P0796130	RAM PINION SCREW M8-1.25 X 60
131	P0796131	RAM GIB
132	P0796132	HEX NUT M8-1.25
133	P0796133	EYE BOLT 38MM, M19-2.5 X 30
134	P0796134	EXT RETAINING RING 28MM
135	P0796135	ANGLE SCALE FOR TURRET
136	P0796136	RIVET 2 X 5MM NAMEPLATE, STEEL
137	P0796137	SCALE INDICATOR
138	P0796138	REAR ENTRY PANEL
139	P0796139	SIDE ENTRY PANEL
140	P0796140	PHLP HD SCR M6-1 X 8
141	P0796141	PHLP HD SCR M6-1 X 12
142	P0796142	BULB HAL 50W 110V BI-PIN
143	P0796143	WORK LAMP
145	P0796145	WORK LAMP BRACKET
146	P0796146	PHLP HD SCR M5-.8 X 12
147	P0796147	CAP SCREW M5-.8 X 8
148	P0796148	DRAIN SCREEN
149V2	P0796149V2	DRO DISPLAY ASSEMBLY GDXH I500 V2.06.20
149V2-1	P0796149V2-1	DRO DISPLAY POWER CORD 28G 3W 118" 5-15P
150	P0796150	DRO MOUNTING ARM
151	P0796151	CAP SCREW M5-.8 X 25
152	P0796152	SET SCREW M6-1 X 16
154	P0796154	X-AXIS DRO SCALE
155	P0796155	Y-AXIS DRO SCALE
158	P0796158	ANGLE SCALE
159	P0796159	LIMIT SWITCH RU 5A 125/250VAC
160	P0796160	LIMIT SWITCH CORD 2W 18G 60"
161	P0796161	CAP SCREW M8-1.25 X 10
162	P0796162	FLAT WASHER 10MM



# G0796 Table Leadscrews

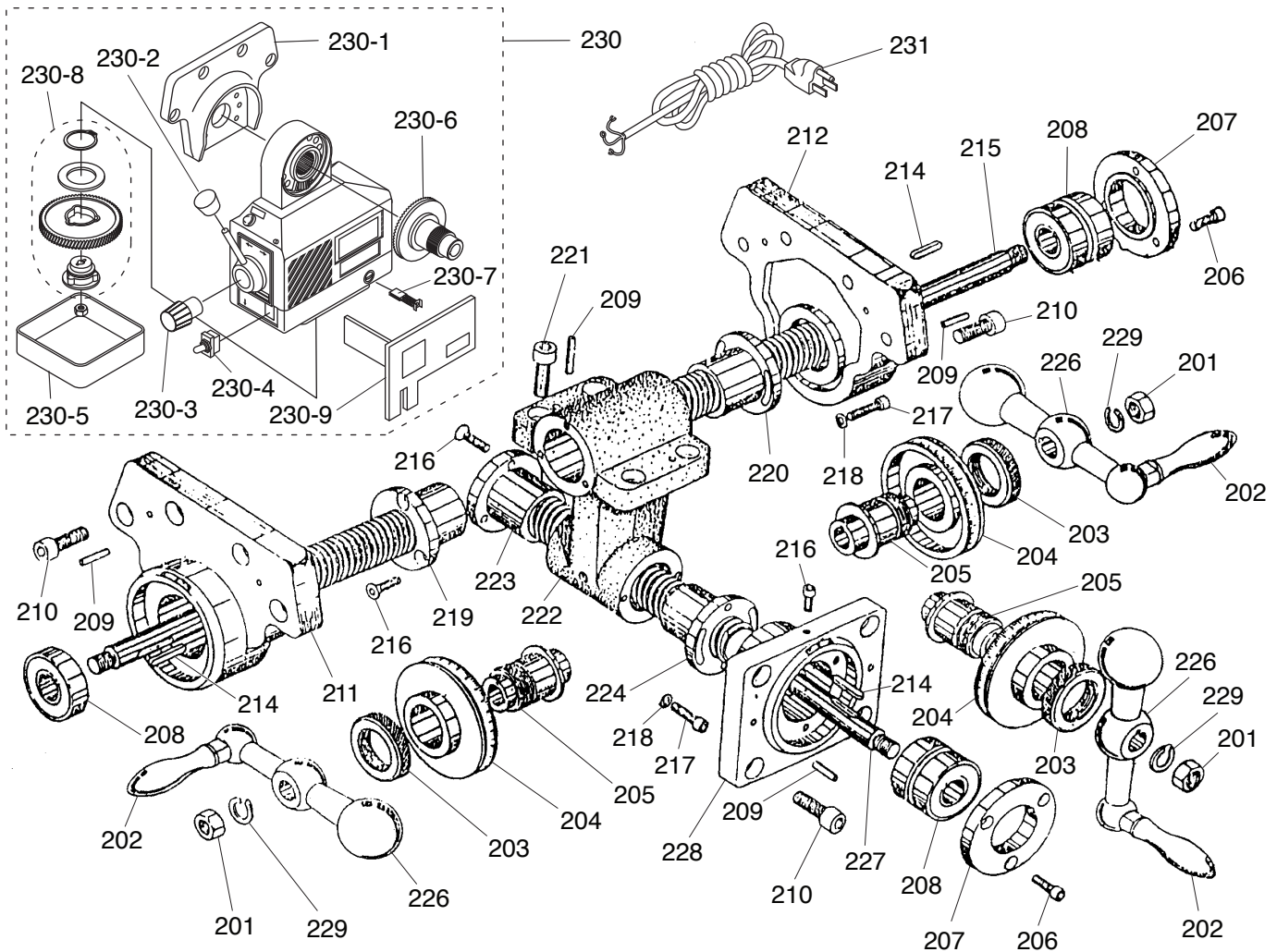

REF	PART #	DESCRIPTION
201	P0796201	Y-AXIS HANDWHEEL HEX NUT 1/2-20
201-1	P0796201-1	X-AXIS HANDWHEEL SHOULDER NUT
202	P0796202	REVOLVING HANDLE 98L, M10-1.5 X 14
203	P0796203	DIAL LOCK NUT M32-1.5
204	P0796204	GRADUATED DIAL 0.002"/0.200"
205	P0796205	DIAL HOLDER
206	P0796206	CAP SCREW M6-1 X 12
207	P0796207	BEARING RETAINER RING
208	P0796208	BALL BEARING 6204ZZ
209	P0796209	ROLL PIN 5 X 30
210	P0796210	CAP SCREW M10-1.5 X 25
211	P0796211	X-AXIS LEADSCREW BRACKET (LEFT)
212	P0796212	X-AXIS LEADSCREW BRACKET (RIGHT)
214	P0796214	KEY 3 X 3 X 25
215	P0796215	X-AXIS LEADSCREW
216	P0796216	FLAT HD CAP SCR M6-1 X 20
217	P0796217	CAP SCREW M6-1 X 25
218	P0796218	FLAT WASHER 6MM
219	P0796219	X-AXIS LEADSCREW NUT (LEFT)
220	P0796220	X-AXIS LEADSCREW NUT (RIGHT)

REF	PART #	DESCRIPTION
221	P0796221	CAP SCREW M10-1.5 X 25
222	P0796222	LEADSCREW NUT BRACKET
223	P0796223	REAR Y-AXIS LEADSCREW NUT
224	P0796224	FRONT Y-AXIS LEADSCREW NUT
226	P0796226	BALL CRANK
227	P0796227	Y-AXIS LEADSCREW
228	P0796228	Y-AXIS LEADSCREW BRACKET
229	P0796229	LOCK WASHER 1/2
230	P0796230	POWER FEED ASSEMBLY
230-1	P0796230-1	MOUNTING BRACKET
230-2	P0796230-2	CONTROL HANDLE
230-3	P0796230-3	SPEED CONTROL KNOB
230-4	P0796230-4	ON/OFF SWITCH
230-5	P0796230-5	BOTTOM COVER
230-6	P0796230-6	BEVEL GEAR
230-7	P0796230-7	CARBON BRUSH
230-8	P0796230-8	ZYTEL GEAR ASSEMBLY
230-9	P0796230-9	CIRCUIT BOARD ASSEMBLY
231	P0796231	POWER CORD 18G 3W 72" 5-15P



# G0796 Headstock

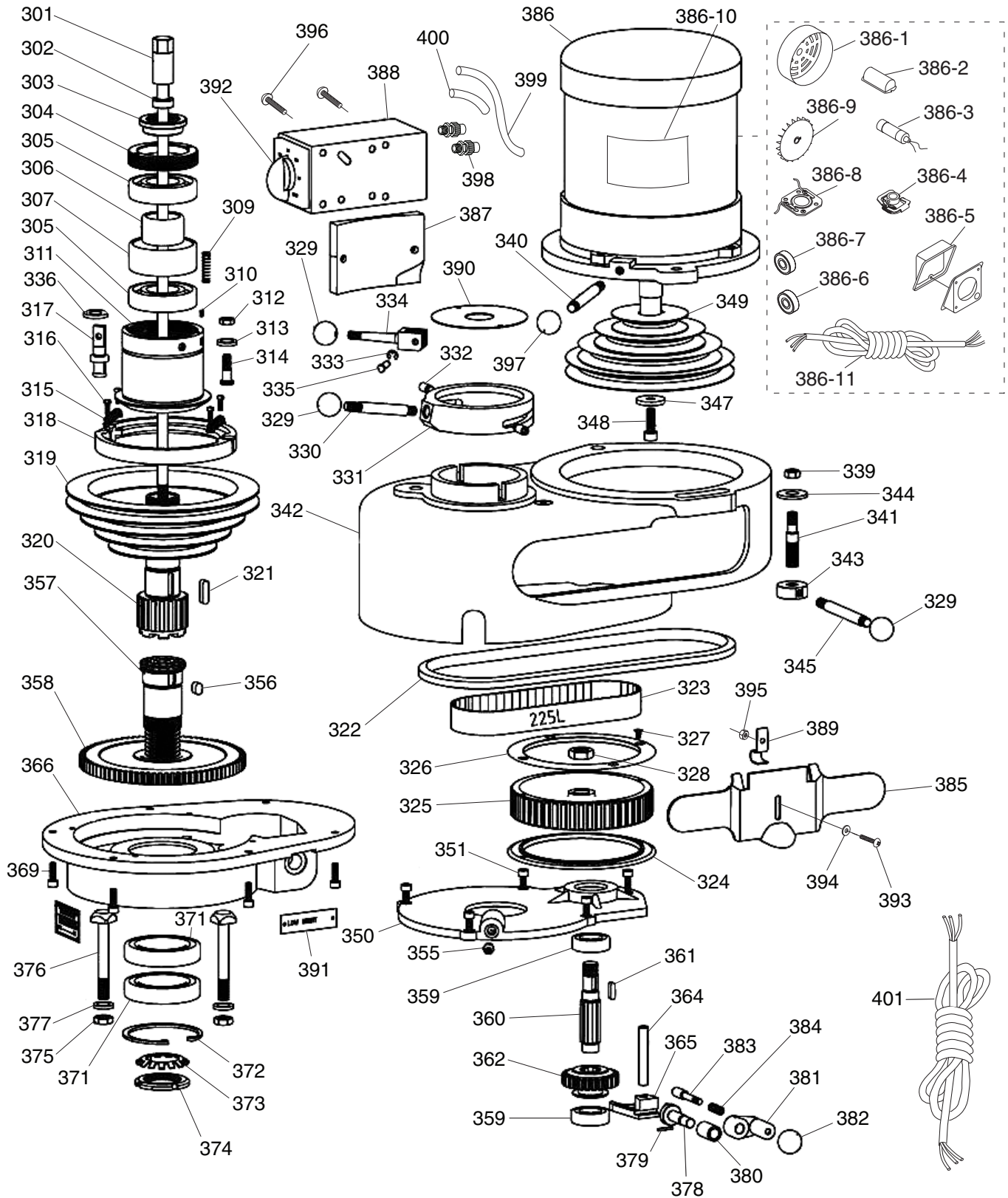

# G0796 Headstock Parts List

REF	PART #	DESCRIPTION
301	P0796301	DRAWBAR 7/16-20 X 20-3/4
302	P0796302	DRAWBAR SPACER 12MM
303	P0796303	UPPER BEARING LOCK NUT
304	P0796304	BEARING SLEEVE LOCK NUT
305	P0796305	BALL BEARING 6207ZZ
306	P0796306	UPPER BEARING SPACER (SMALL)
307	P0796307	UPPER BEARING SPACER (LARGE)
309	P0796309	COMPRESSION SPRING
310	P0796310	SET SCREW M3-.5 X 8
311	P0796311	SPINDLE PULLEY BEARING SLEEVE
312	P0796312	HEX NUT 5/16-18
313	P0796313	EXT TOOTH WASHER 8MM
314	P0796314	BRAKE RING STEP SCREW
315	P0796315	EXTENSION SPRING
316	P0796316	PHLP HD SCR M3-.5 X 20
317	P0796317	BRAKE LOCKING PIN
318	P0796318	BRAKE SHOE ASSEMBLY
319	P0796319	SPINDLE PULLEY
320	P0796320	SPINDLE PULLEY HUB
321	P0796321	KEY 6 X 6 X 25
322	P0796322	V-BELT A34
323	P0796323	TIMING BELT 225L 1"W 60T
324	P0796324	TIMING PULLEY FLANGE
325	P0796325	TIMING PULLEY
326	P0796326	TIMING PULLEY COVER
327	P0796327	FLAT HD SCR 10-24 X 3/8
328	P0796328	HEX NUT 5/8-18
329	P0796329	BALL KNOB 28MM, M8-1.25 BLK
330	P0796330	STUD-UDE M10-1.5 X 105, 17, 8
331	P0796331	CAM RING
332	P0796332	CAM RING PIN M8-1.25 X 24
333	P0796333	E-CLIP 5MM
334	P0796334	BRAKE LEVER
335	P0796335	BRAKE LOCK PIN
336	P0796336	SPACER
339	P0796339	HEX NUT 3/8-24
340	P0796340	STUD-UDE M10-1.5 X 105, 17, 8
341	P0796341	STUD M10-1 X 12, M14-2 X 27, L58
342	P0796342	BELT HOUSING
343	P0796343	MOTOR LOCK NUT
344	P0796344	SPACER
345	P0796345	STUD-UDE M8-1.25 X 58, 12, 7
347	P0796347	DOCK WASHER 30 X 8.5 X 3.5MM
348	P0796348	CAP SCREW M8-1 X 25
349	P0796349	MOTOR PULLEY
350	P0796350	GEAR HOUSING COVER
351	P0796351	PHLP HD SCR M5-.8 X 12
355	P0796355	OIL CUP
356	P0796356	KEY 8 X 8 X 16
357	P0796357	SPLINED GEAR HUB
358	P0796358	SPLINED BULL GEAR 74T

REF	PART #	DESCRIPTION
359	P0796359	BALL BEARING 6203ZZ
360	P0796360	BACK GEAR SHAFT
361	P0796361	KEY 5 X 5 X 15
362	P0796362	BACK GEAR 27T
364	P0796364	PIN M6-1 X 8.5, 58MM
365	P0796365	BACK GEAR SHIFTER FORK
366	P0796366	GEAR HOUSING
369	P0796369	CAP SCREW M6-1 X 20
371	P0796371	BALL BEARING 6208ZZ
372	P0796372	INT RETAINING RING 80MM
373	P0796373	SPANNER NUT LOCK WASHER 38MM
374	P0796374	SPANNER NUT M38-1.25
375	P0796375	HEX NUT 7/16-14
376	P0796376	T-BOLT M12-1.75 X 250
377	P0796377	LOCK WASHER 7/16
378	P0796378	HIGH-LOW SHIFT LEVER
379	P0796379	ROLL PIN 3 X 20
380	P0796380	HIGH-LOW SHIFT BUSHING
381	P0796381	HIGH-LOW SHIFT CRANK
382	P0796382	BALL KNOB 25MM, M6-1 BLK
383	P0796383	DETENT LOCK PIN
384	P0796384	COMPRESSION SPRING
385	P0796385	BELT SAFETY GUARD
386	P0796386	MOTOR 3HP 220V 1-PH
386-1	P0796386-1	MOTOR FAN COVER
386-2	P0796386-2	CAPACITOR COVER
386-3	P0796386-3	S CAPACITOR 500M 275V 2 X 3-3/4
386-4	P0796386-4	CENTRIFUGAL SWITCH
386-5	P0796386-5	MOTOR JUNCTION BOX
386-6	P0796386-6	BALL BEARING 6205ZZ (FRONT)
386-7	P0796386-7	BALL BEARING 6205ZZ (REAR)
386-8	P0796386-8	CONTACT PLATE
386-9	P0796386-9	MOTOR FAN
386-10	P0796386-10	MOTOR LABEL
386-11	P0796386-11	MOTOR CORD 12G 3W 36"
387	P0796387	SWITCH BOX MOUNT PLATE
388	P0796388	SWITCH BOX
389	P0796389	BELT SAFETY GUARD CLIP
390	P0796390	BEARING COVER
391	P0796391	HIGH-LOW RANGE NAMEPLATE
392	P0796392	ROTARY SWITCH JINYI JYW 25
393	P0796393	PHLP HD SCR M5-.8 X 12
394	P0796394	FLAT WASHER 5MM
395	P0796395	HEX NUT M5-.8
396	P0796396	PHLP HD SCR M6-1 X 8
397	P0796397	BALL KNOB 31MM, M10-1.5 BLK
398	P0796398	STRAIN RELIEF M20-1.5 TYPE-5
399	P0796399	CONDUIT 18MM X 2.5M
400	P0796400	CONDUIT 18MM X 0.5M
401	P0796401	POWER CORD 12G 3W 72"



# G0796 Downfeed

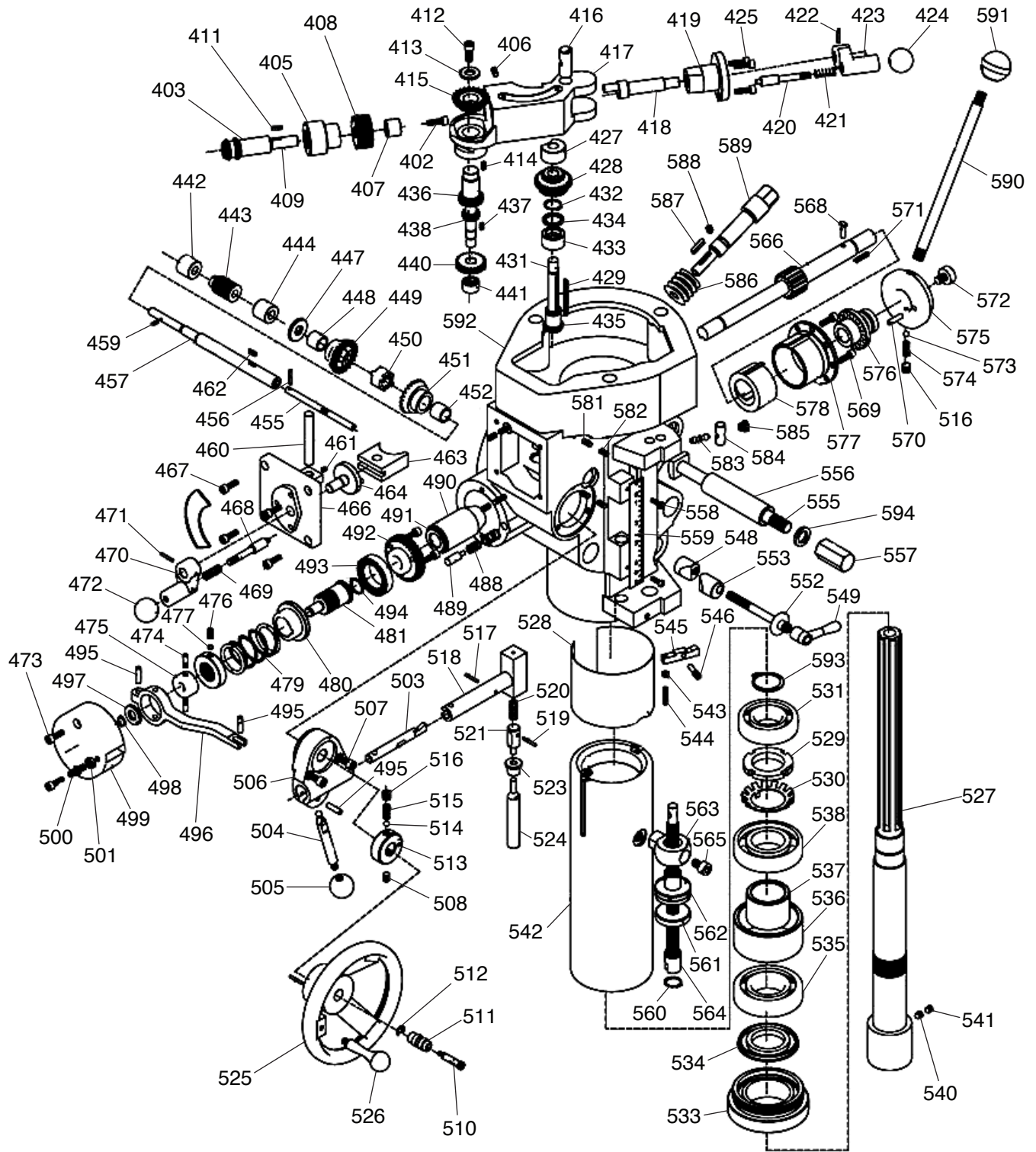

# G0796 Downfeed Parts List

REF	PART #	DESCRIPTION	REF	PART #	DESCRIPTION
402	P0796402	PHLP HD SCR M5-.8 X 10	466	P0796466	CLUSTER GEAR COVER
403	P0796403	FEED BEVEL PINION	467	P0796467	CAP SCREW M5-.8 X 10
405	P0796405	WORM CRADLE BUSHING	468	P0796468	GEAR SHIFT PLUNGER
406	P0796406	SET SCREW 1/4-20 X 1/4	469	P0796469	COMPRESSION SPRING
407	P0796407	WORM CRADLE SPACER	470	P0796470	SHIFT CRANK
408	P0796408	FEED DRIVE WORM GEAR 34T	471	P0796471	ROLL PIN 3 X 15
409	P0796409	FEED DRIVE WORM GEAR SHAFT	472	P0796472	BALL KNOB 25MM, M6-1 BLK
411	P0796411	KEY 3 X 3 X 20	473	P0796473	CAP SCREW M5-.8 X 35
412	P0796412	CAP SCREW M8-1.25 X 12	474	P0796474	CLUTCH RING PIN
413	P0796413	SPACER 8 X 3 X 23	475	P0796475	CLUTCH RING
414	P0796414	KEY 3 X 3 X 8	476	P0796476	SET SCREW M6-1 X 6
415	P0796415	FEED REVERSE BEVEL GEAR 27T	477	P0796477	BRASS PLUG
416	P0796416	FEED ENGAGEMENT PIN	479	P0796479	SAFETY CLUTCH COMPRESSION SPRING
417	P0796417	WORM GEAR CRADLE	480	P0796480	OVERLOAD CLUTCH
418	P0796418	WORM GEAR CRADLE THROW-OUT	481	P0796481	OVERLOAD CLUTCH SLEEVE
419	P0796419	SHIFT SLEEVE	488	P0796488	COMPRESSION SPRING
420	P0796420	GEAR SHIFT PLUNGER	489	P0796489	OVERLOAD CLUTCH SPRING PLUNGER
421	P0796421	COMPRESSION SPRING	490	P0796490	QUILL PINION SHAFT BUSHING
422	P0796422	ROLL PIN 3 X 20	491	P0796491	PINION SHAFT WORM GEAR SPACER
423	P0796423	SHIFT CRANK	492	P0796492	OVERLOAD CLUTCH WORM GEAR 34T
424	P0796424	BALL KNOB 25MM, M6-1 BLK	493	P0796493	OVERLOAD CLUTCH RING
425	P0796425	CAP SCREW M5-.8 X 12	494	P0796494	EXT RETAINING RING 15MM
427	P0796427	SLEEVE BEARING 9.7 X 14.4 X 25.5 (BRASS)	495	P0796495	DOWEL PIN 5 X 20
428	P0796428	CLUSTER COMBO GEAR 32T	496	P0796496	OVERLOAD CLUTCH TRIP LEVER
429	P0796429	KEY 3 X 3 X 45	497	P0796497	CLUTCH WASHER 10 X 3 X 22MM
431	P0796431	CLUSTER GEAR SHAFT	498	P0796498	EXT RETAINING RING 10MM
432	P0796432	EXT RETAINING RING 16MM	499	P0796499	CLUTCH ARM COVER
433	P0796433	SLEEVE BEARING 16 X 13.5 X 24 (BRASS)	500	P0796500	SET SCREW M6-1 X 16
434	P0796434	BEVEL GEAR THRUST WASHER 8MM	501	P0796501	HEX NUT M6-1
435	P0796435	FEED REVERSE BEVEL PINION	503	P0796503	CAM ROD
436	P0796436	FEED DRIVE GEAR 32T	504	P0796504	LEVER SHAFT M5-.8 X 4, M5-.8 X 4, L84
437	P0796437	KEY 3 X 3 X 8	505	P0796505	BALL KNOB 25MM, M6-1 BLK
438	P0796438	CLUSTER GEAR INPUT SHAFT	506	P0796506	FEED TRIP BRACKET
440	P0796440	FEED DRIVE GEAR 27T	507	P0796507	CAP SCREW M6-1 X 20
441	P0796441	NEEDLE BEARING BA66	508	P0796508	SET SCREW M6-1 X 20
442	P0796442	BUSHING	510	P0796510	SHOULDER SCREW M4-.7 X 9 GROOVED
443	P0796443	FEED WORM	511	P0796511	FEED REVERSE KNOB
444	P0796444	FEED WORM SHAFT BUSHING	512	P0796512	EXT RETAINING RING 12MM
447	P0796447	FEED WORM SHAFT THRUST WASHER	513	P0796513	HANDWHEEL CLUTCH
448	P0796448	BUSHING	514	P0796514	STEEL BALL 3/16
449	P0796449	FEED REVERSE BEVEL GEAR 35T	515	P0796515	COMPRESSION SPRING
450	P0796450	FEED REVERSE CLUTCH	516	P0796516	SET SCREW M8-1.25 X 8
451	P0796451	FEED REVERSE BEVEL GEAR 30T	517	P0796517	ROLL PIN 3 X 14
452	P0796452	BUSHING	518	P0796518	CAM ROD SLEEVE ASSEMBLY
455	P0796455	REVERSE CLUTCH ROD	519	P0796519	ROLL PIN 3 X 12
456	P0796456	ROLL PIN 3 X 20	520	P0796520	COMPRESSION SPRING
457	P0796457	FEED WORM SHAFT	521	P0796521	TRIP PLUNGER
459	P0796459	ROLL PIN 3 X 12	523	P0796523	PLUNGER BUSHING
460	P0796460	FEED SHAFT ROD	524	P0796524	FEED TRIP PLUNGER
461	P0796461	SET SCREW M5-.8 X 6	525	P0796525	HANDWHEEL138D X 13B X M8-1.25 DISHED
462	P0796462	KEY 3 X 3 X 15	526	P0796526	HANDWHEEL HANDLE 66L, M8-1.25 X 10
463	P0796463	FEED GEAR SHIFT CRANK	527	P0796527	R-8 SPINDLE
464	P0796464	CLUSTER GEAR SHIFT CRANK	528	P0796528	QUILL SKIRT



# G0796 Downfeed Parts List (Cont.)

REF	PART #	DESCRIPTION
529	P0796529	SPANNER NUT M30-1.5
530	P0796530	EXT TOOTH WASHER 30MM
531	P0796531	BALL BEARING 6206ZZ
533	P0796533	QUILL NOSE PIECE
534	P0796534	LOWER SPINDLE SEAL 64 X 35MM
535	P0796535	ANGULAR CONTACT BEARING 7207
536	P0796536	BEARING SPACER (LARGE)
537	P0796537	BEARING SPACER (SMALL)
538	P0796538	ANGULAR CONTACT BEARING 7207
540	P0796540	SPINDLE SET SCREW M5-.8 X 5
541	P0796541	SET SCREW M6-1 X 6
542	P0796542	QUILL
543	P0796543	HEX NUT M4-.7
544	P0796544	SET SCREW M4-.7 X 16
545	P0796545	FEED TRIP LEVER
546	P0796546	TRIP LEVER PIN
548	P0796548	QUILL LOCK SLEEVE
549	P0796549	ADJUSTABLE HANDLE
552	P0796552	QUICK LOCK BOLT M8-1.25 X 100
553	P0796553	QUILL LOCK SLEEVE M8-1.25
555	P0796555	T-BOLT 1/2-13 X 10"
556	P0796556	SPACER
557	P0796557	HEX CAP NUT 1/2-13 X 1.5"
558	P0796558	PHLP HD SCR M4-.7 X 6
559	P0796559	DOWNFEED MICROMETER SCALE
560	P0796560	EXT RETAINING RING 15MM
561	P0796561	QUILL DEPTH STOP NUT
562	P0796562	MICROMETER NUT
563	P0796563	QUILL STOP KNOB

REF	PART #	DESCRIPTION
564	P0796564	QUILL DEPTH STOP LEADSCREW M13-1 X 160
565	P0796565	CAP SCREW M10-1 X 15
566	P0796566	QUILL PINION SHAFT
568	P0796568	ROLL PIN 3 X 8
569	P0796569	CAP SCREW M5-.8 X 10
570	P0796570	ROLL PIN 3 X 20
571	P0796571	KEY 3 X 3 X 20
572	P0796572	PINION SHAFT HUB SCREW M3-.5 X 20
573	P0796573	STEEL BALL 3/16
574	P0796574	COMPRESSION SPRING
575	P0796575	RACK FEED HANDLE HUB
576	P0796576	PINION SHAFT HUB
577	P0796577	SPRING COVER
578	P0796578	FLAT COIL SPRING
581	P0796581	SET SCREW M4-.7 X 10
582	P0796582	SET SCREW M4-.7 X 6
583	P0796583	REVERSE TRIP LEVER
584	P0796584	FEED REVERSE TRIP PLUNGER
585	P0796585	REVERSE/TRIP LEVER SCREW M8-1.25 X 10
586	P0796586	WORM GEAR
587	P0796587	KEY 4 X 4 X 8
588	P0796588	SET SCREW M3-.5 X 8
589	P0796589	ADJUSTABLE WORM SHAFT
590	P0796590	STUD-UDE M9-1.25 X 10, M11-1.5 X 10, 190L
591	P0796591	BALL KNOB 32MM, M9-1.25 BLK
592	P0796592	QUILL HOUSING
593	P0796593	EXT RETAINING RING 30MM
594	P0796594	FLAT WASHER 12MM





# G0796 One Shot Oiler

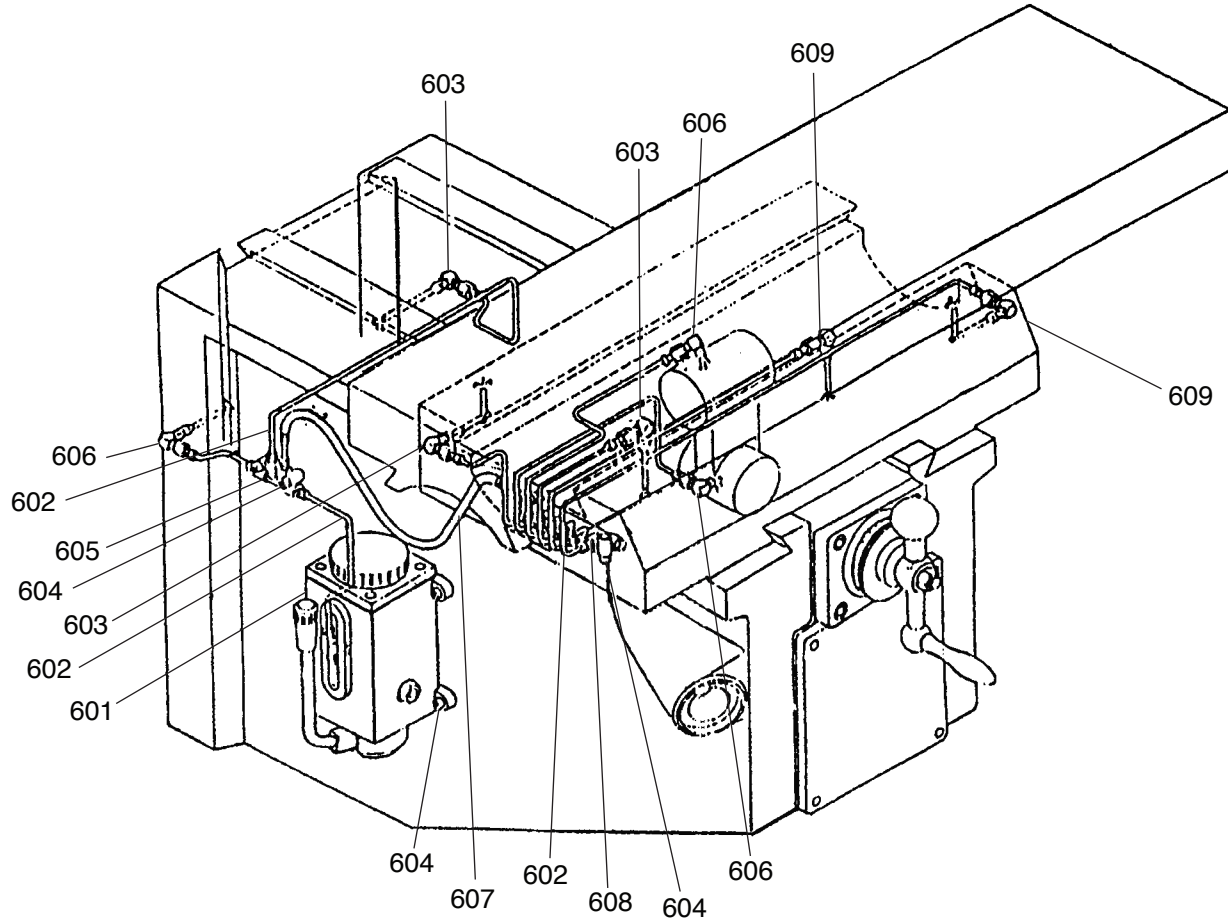

REF	PART #	DESCRIPTION
601	P0796601	OILER PUMP AND RESERVOIR 500CC
602	P0796602	ALUMINUM PIPE
603	P0796603	ELBOW OIL DISTRIBUTOR CPS4
604	P0796604	CAP SCREW M6-1 X 12
605	P0796605	A-TYPE OIL DISTRIBUTOR A4

REF	PART #	DESCRIPTION
606	P0796606	ELBOW OIL DISTRIBUTOR CPS3
607	P0796607	FLEXIBLE STEEL TUBE
608	P0796608	A-TYPE OIL DISTRIBUTOR A8
609	P0796609	ELBOW OIL DISTRIBUTOR CPS5



# G0796 Accessories

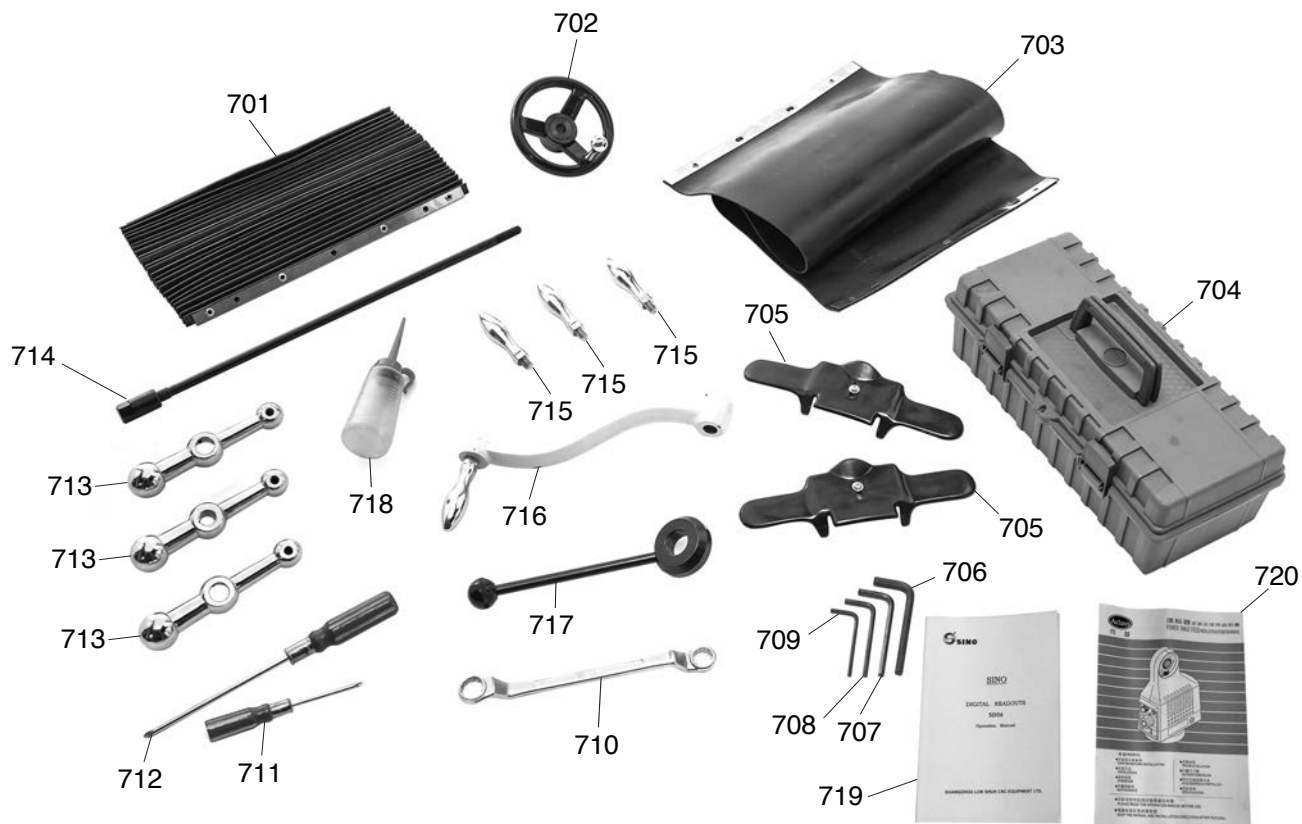

REF PART #	DESCRIPTION
701	P0796701 FRONT WAY COVER
702	P0796702 HANDWHEEL D138 X B13 X M8-1.25 DISHED
703	P0796703 REAR WAY COVER
704	P0796704 TOOLBOX
705	P0796705 BELT HOUSING SAFETY COVER
706	P0796706 HEX WRENCH 8MM
707	P0796707 HEX WRENCH 6MM
708	P0796708 HEX WRENCH 5MM
709	P0796709 HEX WRENCH 4MM
710	P0796710 CLOSED-END WRENCH 17 X 19MM

REF PART #	DESCRIPTION
711	P0796711 SCREWDRIVER PHILLIPS #2
712	P0796712 SCREWDRIVER PHILLIPS #2 EXTRA LONG
713	P0796713 BALL HANDLE
714	P0796714 DRAWBAR
715	P0796715 REVOLVING HANDLE 98L, M10-1.5 X 13
716	P0796716 Z-AXIS CRANK
717	P0796717 COARSE DOWNFEED LEVER
718	P0796718 BOTTLE FOR OIL
719	P0796719 DRO INSTRUCTIONS
720	P0796720 POWER FEED INSTRUCTIONS



# G0796 Labels & Cosmetics

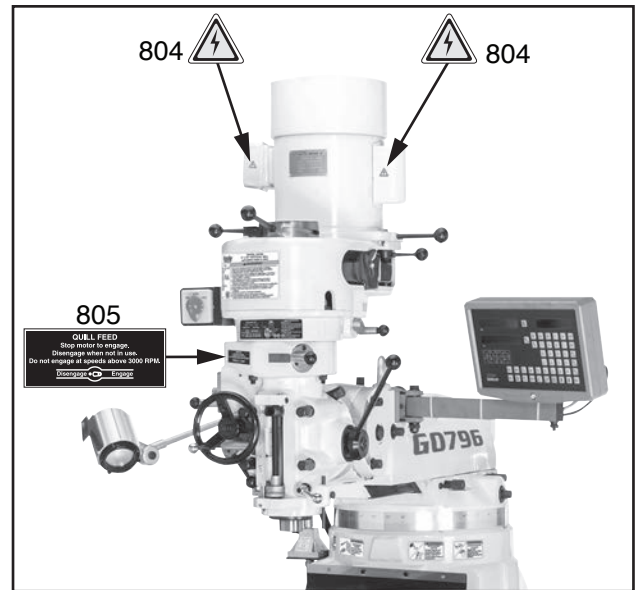
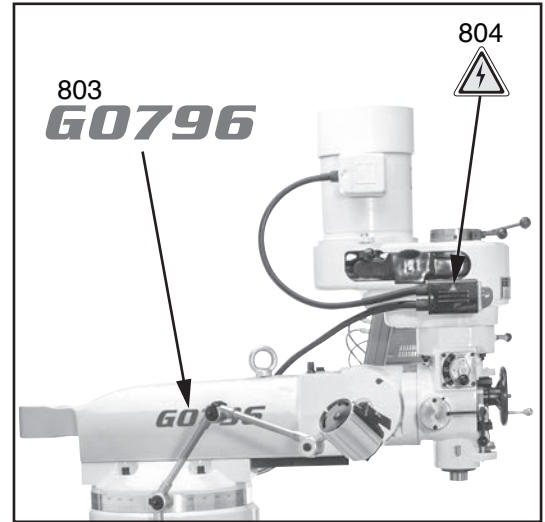
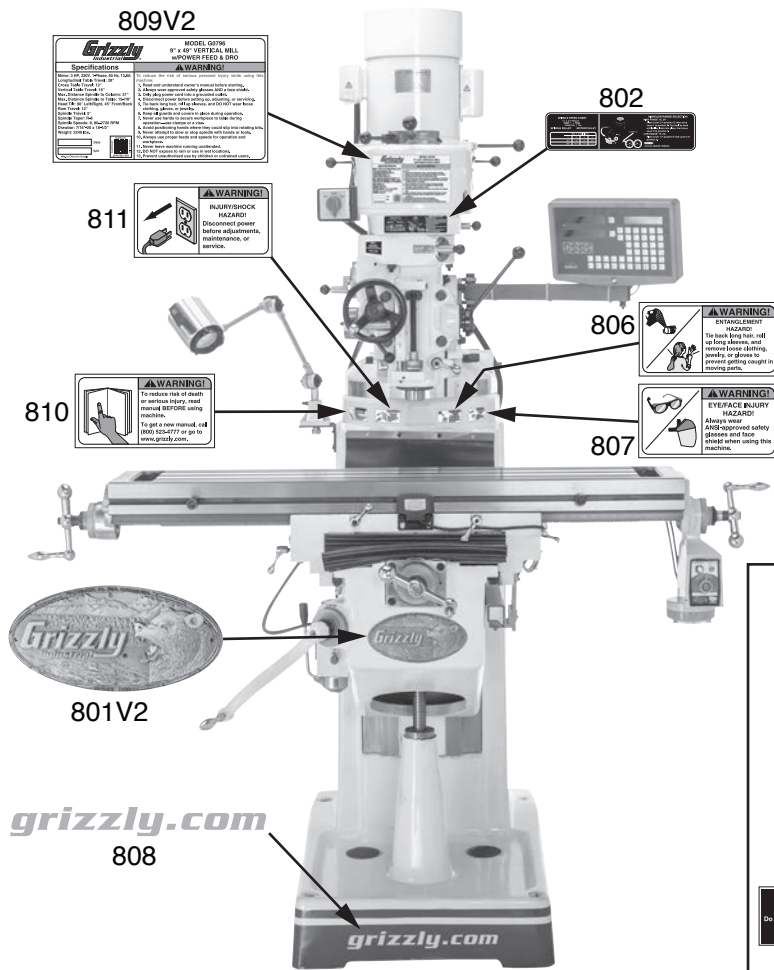

REF	PART #	DESCRIPTION
801V2	P0796801V2	GRIZZLY NAMEPLATE V2.08.18
802	P0796802	SPINDLE SPEED CHART LABEL
803	P0796803	MODEL NUMBER LABEL
804	P0796804	ELECTRICITY LABEL
805	P0796805	QUILL FEED LABEL
806	P0796806	ENTANGLEMENT HAZARD LABEL

REF	PART #	DESCRIPTION
807	P0796807	EYE/FACE INJURY HAZARD LABEL
808	P0796808	GRIZZLY.COM LABEL
809V2	P0796809V2	MACHINE ID LABEL V2.04.18
810	P0796810	READ MANUAL LABEL
811	P0796811	DISCONNECT POWER LABEL

## ⚠️ WARNING

Safety labels help reduce the risk of serious injury caused by machine hazards. If any label comes off or becomes unreadable, the owner of this machine **MUST** replace it in the original location before resuming operations. For replacements, contact (800) 523-4777 or [www.grizzly.com](http://www.grizzly.com).



# G0797 Main Body

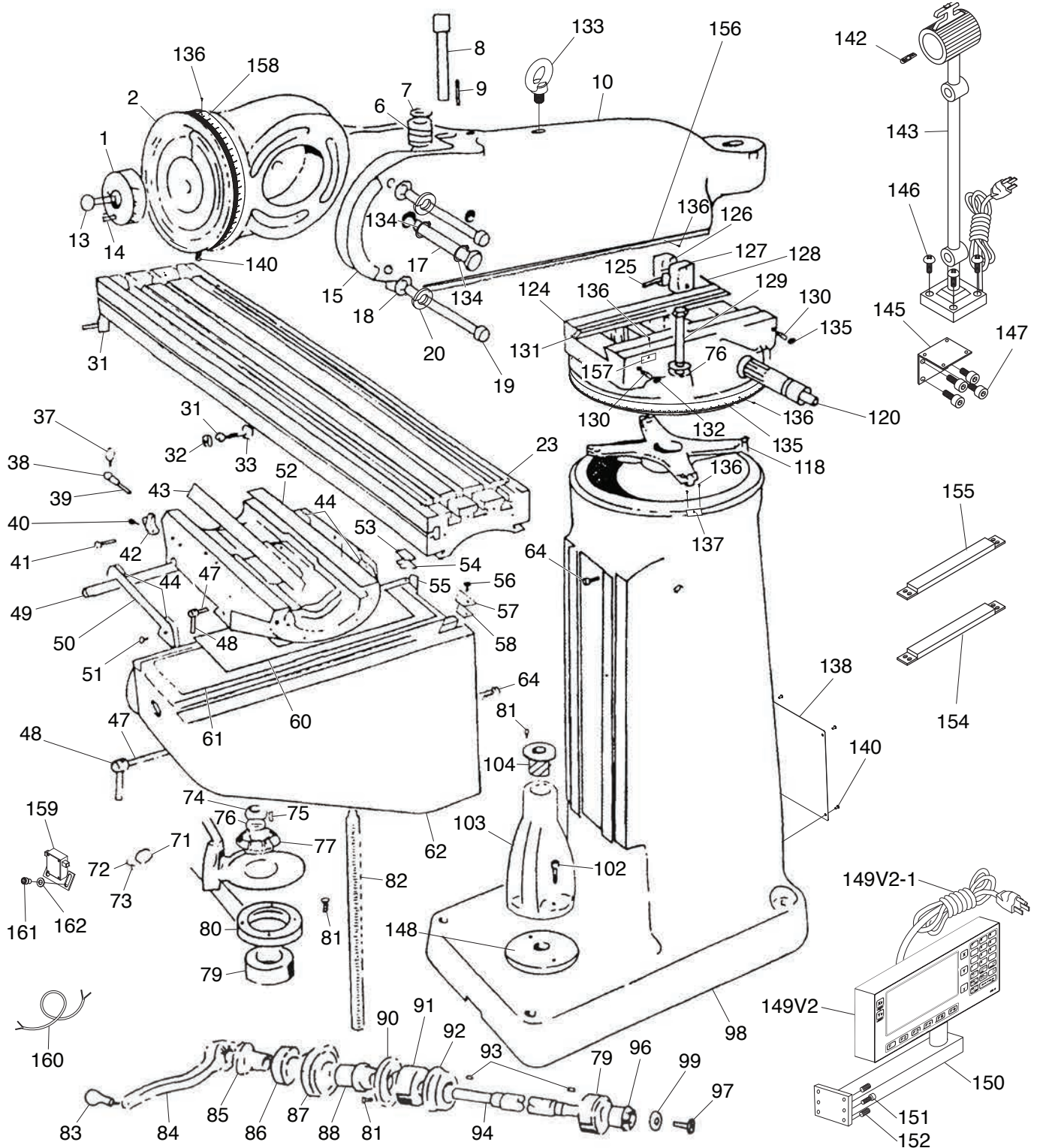

# G0797 Main Body Parts List

REF	PART #	DESCRIPTION
1	P0797001	QUILL HOUSING ADJUSTMENT GEAR 46T
2	P0797002	RAM ADAPTER
6	P0797006	HEAD TILT ADJUSTING WORM
7	P0797007	WORM THRUST WASHER 8MM
8	P0797008	HEAD TILT ADJUSTING WORM SHAFT
9	P0797009	KEY 5 X 5 X 50
10	P0797010	RAM CASTING
13	P0797013	CAP SCREW M6-1 X 25
14	P0797014	ROLL PIN 8 X 30
15	P0797015	HEAD TILT SCALE
17	P0797017	ADAPTER PIVOT SHAFT 28 X 190
18	P0797018	FLAT WASHER 14MM
19	P0797019	HEX BOLT M14-2 X 190
20	P0797020	LOCK WASHER 14MM
23	P0797023	TABLE 10" X 50"
31	P0797031	CAP SCREW M8-1.25 X 35
32	P0797032	LIMIT STOP
33	P0797033	SQUARE NUT M8-1.25
37	P0797037	SADDLE LOCK BOLT HANDLE
38	P0797038	SADDLE LOCK BOLT M12-1.75 X 25
39	P0797039	SADDLE LOCK BOLT PLUNGER
40	P0797040	CAP SCREW 3/8-16 X 3/4
41	P0797041	GIB ADJUSTING SCREW 3/8-16 X 3/4
42	P0797042	TABLE STOP BRACKET
43	P0797043	TABLE GIB
44	P0797044	SADDLE WAY WIPER
47	P0797047	TABLE LOCK BOLT M12-1.75 X 25
48	P0797048	ADJUSTABLE HANDLE ASSY
49	P0797049	SADDLE GIB
50	P0797050	SADDLE WIPER HOLDER
51	P0797051	PHLP HD SCR 10-24 X 1/2
52	P0797052	SADDLE CASTING
53	P0797053	COLUMN WAY WIPER HOLDER (LEFT)
54	P0797054	COLUMN WAY WIPER (LEFT)
55	P0797055	KNEE GIB
56	P0797056	CAP SCREW M6-1 X 12
57	P0797057	COLUMN WAY WIPER HOLDER (RIGHT)
58	P0797058	COLUMN WAY WIPER (RIGHT)
60	P0797060	UPPER SADDLE COVER
61	P0797061	LOWER SADDLE COVER
62	P0797062	KNEE CASTING
64	P0797064	KNEE STOP BOLT
71	P0797071	KNEE PLUG (PLASTIC)
72	P0797072	SET SCREW 10-24 X 1/2 DOG-PT
73	P0797073	SET SCREW 10-24 X 1/2
74	P0797074	HEX NUT 1/2-20
75	P0797075	KEY 5 X 5 X 20
76	P0797076	FLAT WASHER 1/2
77	P0797077	Z-AXIS BEVEL GEAR 27T
79	P0797079	BALL BEARING 6207ZZ
80	P0797080	BEARING RETAINER RING
81	P0797081	CAP SCREW M6-1 X 20
82	P0797082	Z-AXIS LEADSCREW
83	P0797083	CRANK HANDLE
84	P0797084	Z-AXIS CRANK ARM

REF	PART #	DESCRIPTION
85	P0797085	CLUTCH
86	P0797086	DIAL LOCK NUT
87	P0797087	GRADUATED DIAL 0.001"/0.100"
88	P0797088	DIAL HOLDER
90	P0797090	BEARING RETAINER RING
91	P0797091	BALL BEARING 6204ZZ
92	P0797092	BEARING CAP
93	P0797093	KEY 3 X 3 X 18
94	P0797094	Z-AXIS SHAFT
96	P0797096	BEVELED PINION GEAR 32T
97	P0797097	SET SCREW M6-1 X 6
98	P0797098	COLUMN CASTING
99	P0797099	FLAT WASHER 3/4
102	P0797102	CAP SCREW M10-1.5 X 25
103	P0797103	Z-AXIS PEDESTAL
104	P0797104	Z-AXIS LEADSCREW NUT
118	P0797118	RAM SWIVEL
120	P0797120	RAM PINION
124	P0797124	TURRET
125	P0797125	RAM CLAMP BAR
126	P0797126	UNTAPPED RAM CLAMP
127	P0797127	TAPPED RAM CLAMP
128	P0797128	ROLL PIN 10 X 20
129	P0797129	RAM LOCK BOLT M12-1.75 X 250
130	P0797130	RAM PINION SCREW M8-1.25 X 60
131	P0797131	RAM GIB
132	P0797132	HEX NUT M8-1.25
133	P0797133	EYE BOLT 38MM, M19-2.5 X 30
134	P0797134	EXT RETAINING RING 28MM
135	P0797135	ANGLE SCALE FOR TURRET
136	P0797136	RIVET 2 X 5MM NAMEPLATE, STEEL
137	P0797137	SCALE INDICATOR
138	P0797138	REAR ENTRY PANEL
140	P0797140	PHLP HD SCR M6-1 X 8
142	P0797142	BULB HAL 50W 110V BI-PIN
143	P0797143	WORK LAMP
145	P0797145	WORK LAMP BRACKET
146	P0797146	PHLP HD SCR M5-.8 X 12
147	P0797147	CAP SCREW M5-.8 X 8
148	P0797148	DRAIN SCREEN
149V2	P0797149V2	DRO DISPLAY ASSEMBLY GDXH I500 V2.06.20
149V2-1	P0797149V2-1	DRO DISPLAY POWER CORD 28G 3W 118" 5-15P
150	P0797150	DRO MOUNTING ARM
151	P0797151	CAP SCREW M5-.8 X 25
152	P0797152	SET SCREW M6-1 X 16
154	P0797154	X-AXIS DRO SCALE
155	P0797155	Y-AXIS DRO SCALE
156	P0797156	RAM SCALE
157	P0797157	RAM SCALE INDICATOR
158	P0797158	ANGLE SCALE
159	P0797159	LIMIT SWITCH RU 5A 125/250VAC
160	P0797160	LIMIT SWITCH CORD 2W 18G 60"
161	P0797161	CAP SCREW M8-1.25 X 10
162	P0797162	FLAT WASHER 10MM



# G0797 Table Leadscrews

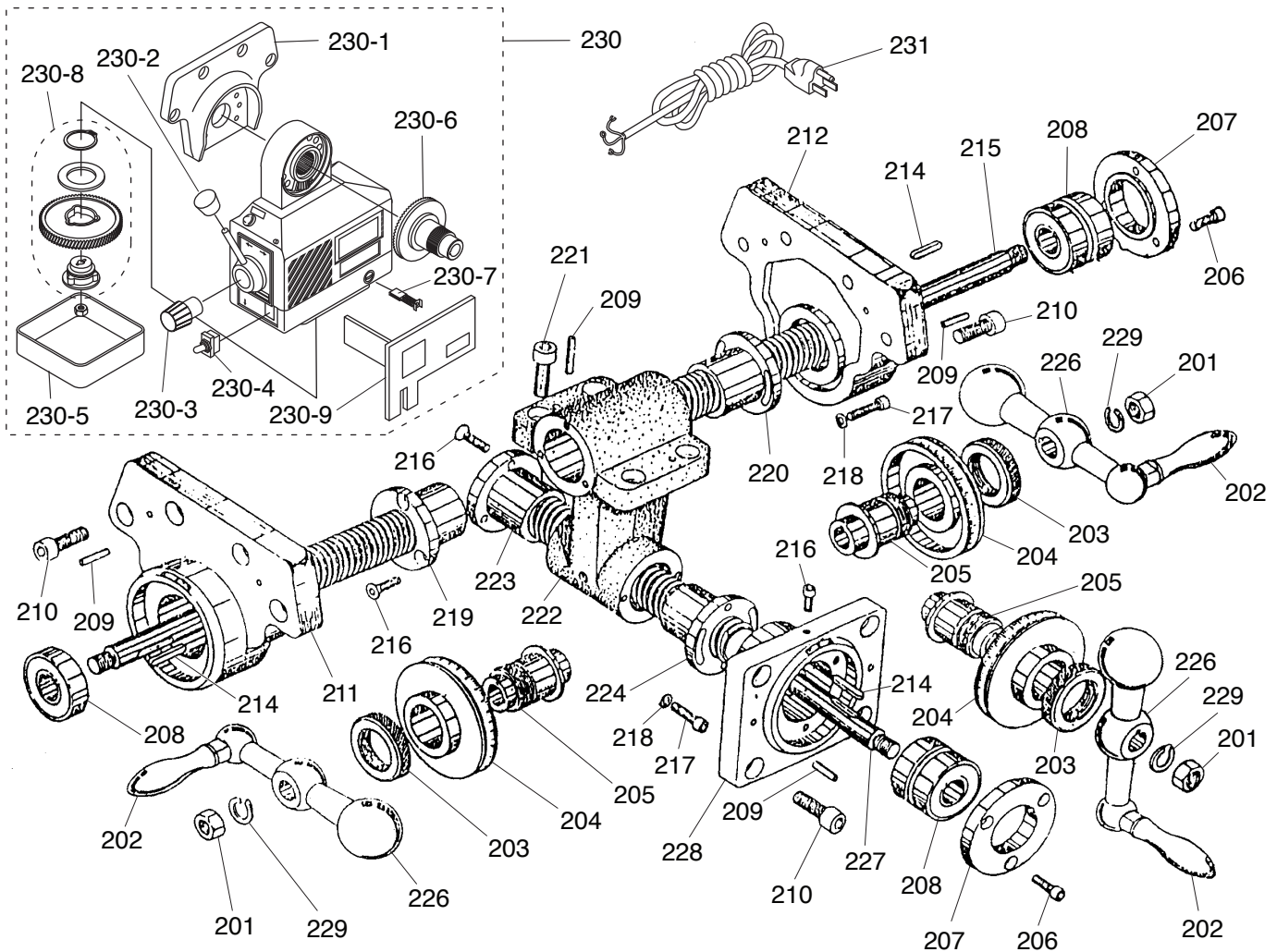

REF	PART #	DESCRIPTION
201	P0797201	HEX NUT 1/2-20
202	P0797202	REVOLVING HANDLE 98L, M10-1.5 X 14
203	P0797203	DIAL LOCK NUT M32-1.5
204	P0797204	GRADUATED DIAL 0.002"/0.200"
205	P0797205	DIAL HOLDER
206	P0797206	CAP SCREW M6-1 X 12
207	P0797207	BEARING RETAINER RING
208	P0797208	BALL BEARING 6204ZZ
209	P0797209	ROLL PIN 5 X 30
210	P0797210	CAP SCREW M10-1.5 X 25
211	P0797211	X-AXIS LEADSCREW BRACKET (LEFT)
212	P0797212	X-AXIS LEADSCREW BRACKET (RIGHT)
214	P0797214	KEY 3 X 3 X 25
215	P0797215	X-AXIS LEADSCREW
216	P0797216	FLAT HD CAP SCR M6-1 X 20
217	P0797217	CAP SCREW M6-1 X 25
218	P0797218	FLAT WASHER 6MM
219	P0797219	X-AXIS LEADSCREW NUT (LEFT)
220	P0797220	X-AXIS LEADSCREW NUT (RIGHT)

REF	PART #	DESCRIPTION
221	P0797221	CAP SCREW M10-1.5 X 25
222	P0797222	LEADSCREW NUT BRACKET
223	P0797223	REAR Y-AXIS LEADSCREW NUT
224	P0797224	FRONT Y-AXIS LEADSCREW NUT
226	P0797226	BALL CRANK
227	P0797227	Y-AXIS LEADSCREW
228	P0797228	Y-AXIS LEADSCREW BRACKET
229	P0797229	LOCK WASHER 1/2
230	P0796230	POWER FEED ASSEMBLY
230-1	P0796230-1	MOUNTING BRACKET
230-2	P0796230-2	CONTROL HANDLE
230-3	P0796230-3	SPEED CONTROL KNOB
230-4	P0796230-4	ON/OFF SWITCH
230-5	P0796230-5	BOTTOM COVER
230-6	P0796230-6	BEVEL GEAR
230-7	P0796230-7	CARBON BRUSH
230-8	P0796230-8	ZYTEL GEAR ASSEMBLY
230-9	P0796230-9	CIRCUIT BOARD ASSEMBLY
231	P0796231	POWER CORD 18G 3W 72" 5-15P



# G0797 Headstock

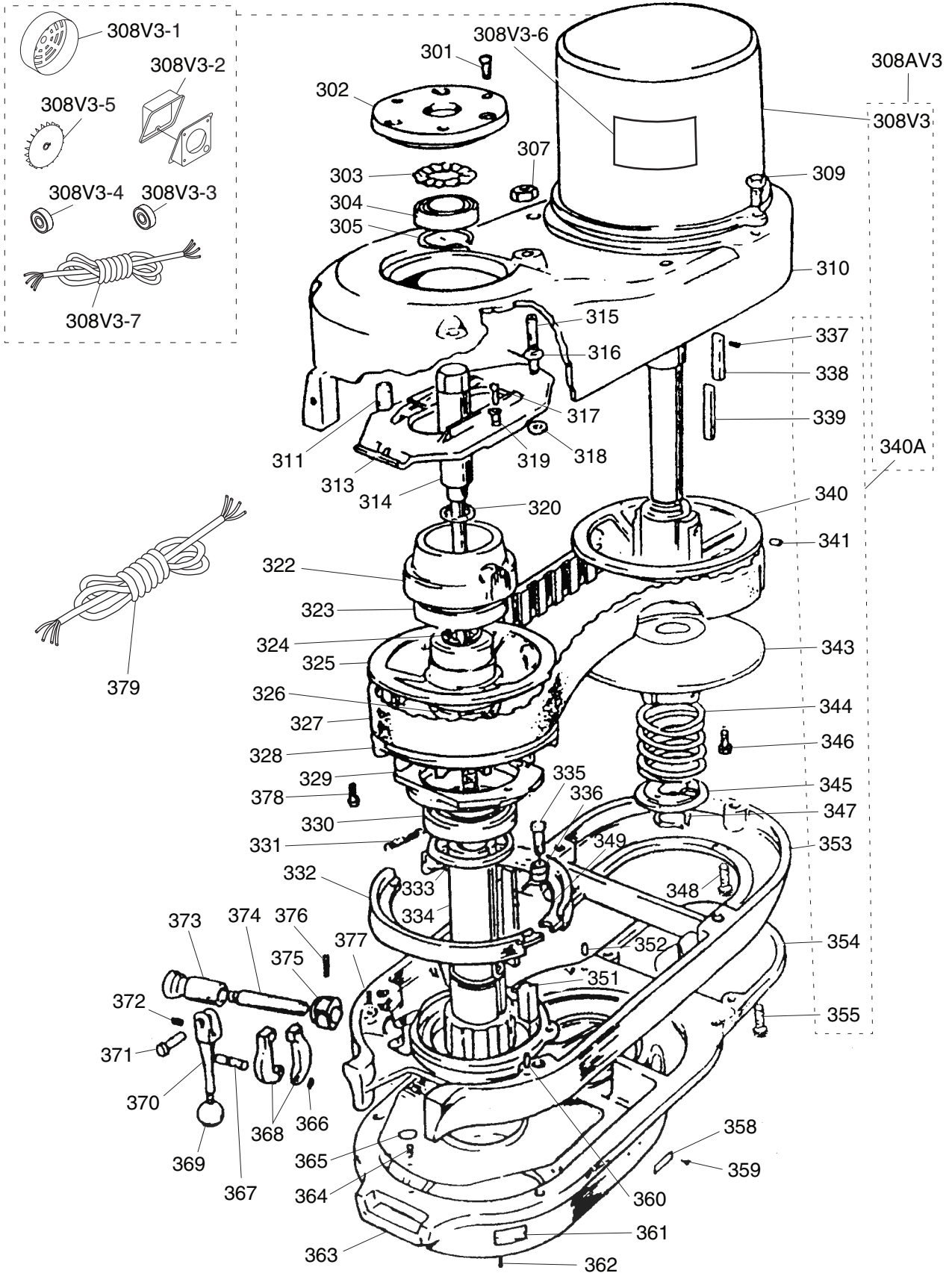

# G0797 Headstock Parts List

REF	PART #	DESCRIPTION
301	P0797301	CAP SCREW M6-1 X 25
302	P0797302	BEARING CAP (UPPER)
303	P0797303	LOCK WASHER 40MM
304	P0797304	BALL BEARING 6007ZZ
305	P0797305	INT RETAINING RING 40MM
307	P0797307	HEX NUT 3/8-16
308AV3	P0797308AV3	MOTOR WITH PULLEY ASSEMBLY V3.08.18
308V3	P0797308V3	MOTOR 3HP 220V/440V 3-PH V3.08.18
308V3-1	P0797308V3-1	MOTOR FAN COVER
308V3-2	P0797308V3-2	MOTOR JUNCTION BOX
308V3-3	P0797308V3-3	BALL BEARING 6206ZZ (FRONT)
308V3-4	P0797308V3-4	BALL BEARING 6205ZZ (REAR)
308V3-5	P0797308V3-5	MOTOR FAN
308V3-6	P0797308V3-6	MOTOR LABEL
308V3-7	P0797308V3-7	MOTOR CORD 14G 4W 36"
309	P0797309	CAP SCREW M10-1.5 X 30
310	P0797310	BELT HOUSING
311	P0797311	SPEED CHANGE BOLT M8-1.25 X 15
313	P0797313	SPEED CHANGER PLATE
314	P0797314	DRAWBAR 7/16-20 X 23-1/2
315	P0797315	ALIGNMENT PIN
316	P0797316	SPEED CHANGE PIVOT BOLT M10-1.5 X 48
317	P0797317	CAP SCREW M5-.8 X 20
318	P0797318	FLAT WASHER 8MM
319	P0797319	PIVOT BOLT SLEEVE
320	P0797320	DRAWBAR WASHER
322	P0797322	BEARING HOUSING
323	P0797323	BALL BEARING 6012ZZ
324	P0797324	SPACER (PLASTIC)
325	P0797325	ADJUSTABLE SPINDLE PULLEY PLATE
326	P0797326	EXT RETAINING RING 40MM
327	P0797327	V-BELT, VARIABLE SPEED 900VC3830
328	P0797328	STATIONARY SPINDLE PULLEY PLATE
329	P0797329	BEARING BRAKE CAP
330	P0797330	BALL BEARING 6010ZZ
331	P0797331	BRAKE EXTENSION SPRING
332	P0797332	BRAKE SHOE ASSEMBLY
333	P0797333	SPINDLE PULLEY SPACER
334	P0797334	SPINDLE PULLEY HUB
335	P0797335	HEX BOLT M6-1 X 20
336	P0797336	PIVOT SLEEVE

REF	PART #	DESCRIPTION
337	P0797337	ROLL PIN 3 X 12
338	P0797338	KEY 7 X 7 X 25
339	P0797339	KEY 7 X 7 X 30
340A	P0797340A	PULLEY ASSEMBLY
340	P0797340	STATIONARY MOTOR PULLEY PLATE
341	P0797341	SET SCREW M8-1.25 X 8
343	P0797343	ADJUSTABLE MOTOR PULLEY PLATE
344	P0797344	COMPRESSION SPRING
345	P0797345	SPRING COLLAR
346	P0797346	CAP SCREW M4-.7 X 10
347	P0797347	EXT RETAINING RING 28MM
348	P0797348	CAP SCREW M8-1.25 X 25
349	P0797349	SPINDLE KEY 8 X 8 X 16 (PLASTIC)
351	P0797351	KEY 8 X 8 X 12
352	P0797352	TAPER PIN 3 X 12
353	P0797353	BELT HOUSING
354	P0797354	MOTOR PULLEY COVER
355	P0797355	CAP SCREW M6-1 X 16
358	P0797358	HIGH-LOW RANGE NAMEPLATE
359	P0797359	DRIVE SCREW M5-.8 X 10
360	P0797360	TAPER PIN 3 X 12
361	P0797361	QUILL FEED NAMEPLATE
362	P0797362	RIVET 4 X 16
363	P0797363	GEAR HOUSING
364	P0797364	PHLP HD SCR 5-40 X 1/4
365	P0797365	GEAR HOUSING PLATE
366	P0797366	E-CLIP 40MM
367	P0797367	CLEVIS PIN
368	P0797368	BRAKE FINGER ASSY 2-PC
369	P0797369	BALL KNOB 25MM, M6-1 BLK
370	P0797370	BRAKE LEVER
371	P0797371	BRAKE LOCK PIN 3 X 14
372	P0797372	SET SCREW M4-.7 X 6
373	P0797373	SHAFT SLEEVE
374	P0797374	BRAKE LOCK SHAFT
375	P0797375	BRAKE LOCK CAM
376	P0797376	ROLL PIN 3 X 12
377	P0797377	SET SCREW M4-.7 X 10
378	P0797378	CAP SCREW M6-1 X 12
379	P0797379	POWER CORD 14G 4W 72"





# G0797 Headstock Gearing

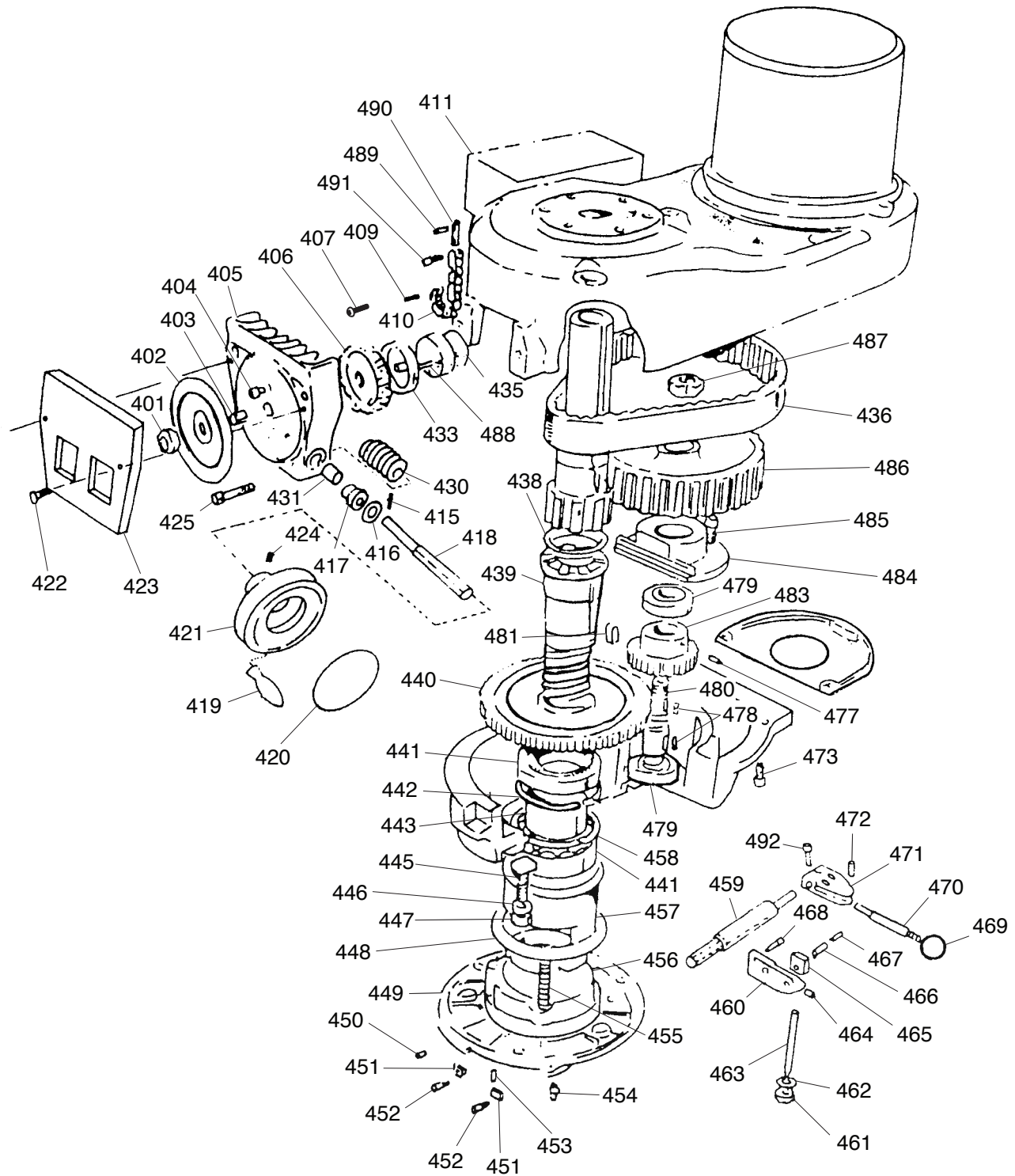

# G0797 Headstock Gearing Parts List

REF PART #	DESCRIPTION	REF PART #	DESCRIPTION		
401	P0797401	ACORN NUT 5/16-18	451	P0797451	CLUTCH BRACKET GUIDE
402	P0797402	VARIABLE-SPEED DISPLAY WHEEL	452	P0797452	FLAT HD CAP SCR 10-24 X 3/8
403	P0797403	BUSHING (BRONZE)	453	P0797453	DOWEL PIN 3 X 12
404	P0797404	SET SCREW 10-24 X 3/4 DOG-PT	454	P0797454	OIL CUP
405	P0797405	SPEED CHANGER HOUSING	455	P0797455	COMPRESSION SPRING
406	P0797406	SPEED CHANGER CHIP SHIELD	456	P0797456	BEARING LOCK NUT
407	P0797407	PHLP HD SCR M6-1 X 6	457	P0797457	BEARING SLEEVE
409	P0797409	ROLL PIN 5 X 10	458	P0797458	WAVY WASHER 62MM
410	P0797410	SPEED CHANGER CHAIN	459	P0797459	BULL GEAR SHIFT PINION
411	P0797411	ROTARY SWITCH TEND HDD300 (F,O,R)	460	P0797460	HIGH-LOW DETENT PLATE
415	P0797415	ROLL PIN 3 X 12	461	P0797461	HEX NUT M10-1.5
416	P0797416	BEARING WASHER 30MM	462	P0797462	LOCK WASHER 10MM
417	P0797417	BALL BEARING 6206ZZ	463	P0797463	STUD FT M10-1.5 X 20
418	P0797418	SPEED CHANGER SHAFT	464	P0797464	SET SCREW M6-1 X 16
419	P0797419	FIXED HANDLE 66L, M8-1.25 X 10 CHROME	465	P0797465	ADJUSTMENT PLATE
420	P0797420	SPEED CHANGER CAUTION PLATE	466	P0797466	DETENT PLUNGER
421	P0797421	HANDWHEEL 85D X 10B X M10-1.5 FLAT	467	P0797467	COMPRESSION SPRING
422	P0797422	FLAT HD CAP SCR M4-.7 X 6	468	P0797468	CAP SCREW M6-1 X 16
423	P0797423	VARIABLE-SPEED DISPLAY COVER	469	P0797469	BALL KNOB 25MM, M6-1 BLK
424	P0797424	SET SCREW M3-.5 X 20	470	P0797470	SPRING STUD-SWIVEL M6-1 X 14
425	P0797425	CAP SCREW M6-1 X 30	471	P0797471	HIGH-LOW PINION BLOCK
430	P0797430	WORM GEAR	472	P0797472	ROLL PIN 3 X 18
431	P0797431	BALL BEARING 6012ZZ	473	P0797473	CAP SCREW M6-1 X 16
433	P0797433	SPEED CHANGER SPUR GEAR	477	P0797477	SET SCREW M8-1 X 6
435	P0797435	SPEED CHANGER CHAIN DRUM	478	P0797478	KEY 5 X 5 X 15
436	P0797436	TIMING BELT 225L 1"W 60T	479	P0797479	BALL BEARING 6203ZZ
438	P0797438	TIMING PULLEY CLUTCH SLEEVE	480	P0797480	BULL GEAR PINION COUNTERSHAFT
439	P0797439	SPINDLE BULL GEAR HUB	481	P0797481	KEY 5 X 5 X 18
440	P0797440	SPINDLE BULL GEAR 81T	483	P0797483	BULL GEAR PINION
441	P0797441	BALL BEARING 6908ZZ	484	P0797484	BULL GEAR PINION BEARING CAP
442	P0797442	SLEEVE	485	P0797485	CAP SCREW M5-.8 X 20
443	P0797443	BULL GEAR BEARING SPACER	486	P0797486	TIMING BELT PULLEY
445	P0797445	T-BOLT M12-1.75 X 250	487	P0797487	HEX NUT 5/8-18 THIN
446	P0797446	FLAT WASHER 12MM	488	P0797488	ROLL PIN 3 X 12
447	P0797447	HEX NUT M12-1.75	489	P0797489	ROLL PIN 3 X 18
448	P0797448	GEAR SLEEVE WASHER	490	P0797490	SPEED BOLT M10-1 X 12, M13-2 X 27, L58
449	P0797449	FIXED CLUTCH BRACKET	491	P0797491	COTTER PIN 3 X 24
450	P0797450	SET SCREW 10-24 X 3/8	492	P0797492	CAP SCREW M5-.8 X 12



# G0797 Downfeed

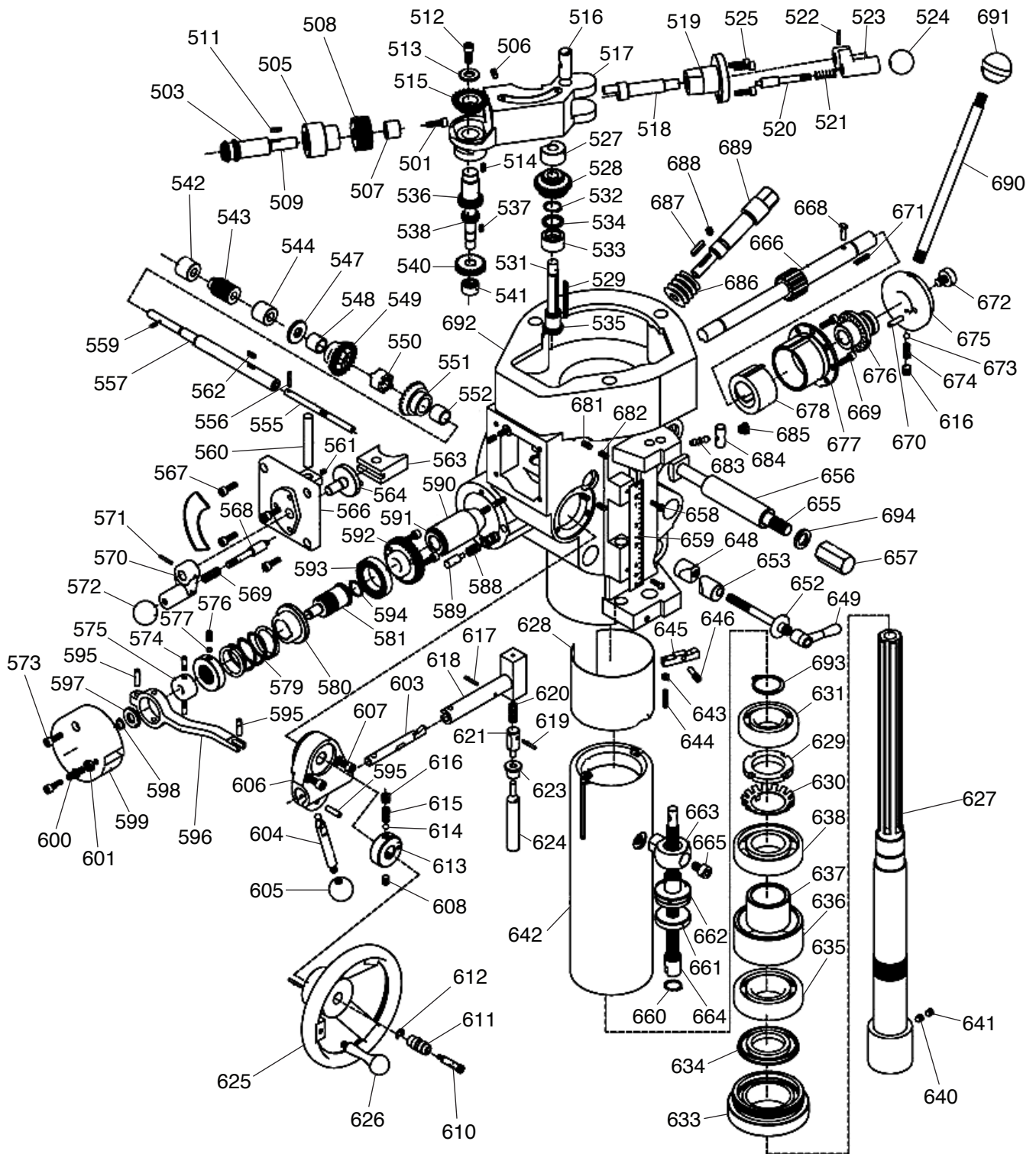

# G0797 Downfeed Parts List

REF PART #	DESCRIPTION	REF PART #	DESCRIPTION		
501	P0797501	PHLP HD SCR M5-.8 X 10	566	P0797566	CLUSTER GEAR COVER
503	P0797503	FEED BEVEL PINION	567	P0797567	CAP SCREW M5-.8 X 10
505	P0797505	WORM CRADLE BUSHING	568	P0797568	GEAR SHIFT PLUNGER
506	P0797506	SET SCREW 1/4-20 X 1/4	569	P0797569	COMPRESSION SPRING
507	P0797507	WORM CRADLE SPACER	570	P0797570	SHIFT CRANK
508	P0797508	FEED DRIVE WORM GEAR 34T	571	P0797571	ROLL PIN 3 X 15
509	P0797509	FEED DRIVE WORM GEAR SHAFT	572	P0797572	BALL KNOB 25MM, M6-1 BLK
511	P0797511	KEY 3 X 3 X 20	573	P0797573	CAP SCREW M5-.8 X 35
512	P0797512	CAP SCREW M8-1.25 X 12	574	P0797574	CLUTCH RING PIN
513	P0797513	SPACER 8 X 3 X 23	575	P0797575	CLUTCH RING
514	P0797514	KEY 3 X 3 X 8	576	P0797576	SET SCREW M6-1 X 6
515	P0797515	FEED REVERSE BEVEL GEAR 27T	577	P0797577	BRASS PLUG
516	P0797516	FEED ENGAGEMENT PIN	579	P0797579	SAFETY CLUTCH COMPRESSION SPRING
517	P0797517	WORM GEAR CRADLE	580	P0797580	OVERLOAD CLUTCH
518	P0797518	WORM GEAR CRADLE THROW-OUT	581	P0797581	OVERLOAD CLUTCH SLEEVE
519	P0797519	SHIFT SLEEVE	588	P0797588	COMPRESSION SPRING
520	P0797520	GEAR SHIFT PLUNGER	589	P0797589	OVERLOAD CLUTCH SPRING PLUNGER
521	P0797521	COMPRESSION SPRING	590	P0797590	QUILL PINION SHAFT BUSHING
522	P0797522	ROLL PIN 3 X 20	591	P0797591	PINION SHAFT WORM GEAR SPACER
523	P0797523	SHIFT CRANK	592	P0797592	OVERLOAD CLUTCH WORM GEAR 34T
524	P0797524	BALL KNOB 25MM, M6-1 BLK	593	P0797593	OVERLOAD CLUTCH RING
525	P0797525	CAP SCREW M5-.8 X 12	594	P0797594	EXT RETAINING RING 15MM
527	P0797527	SLEEVE BEARING 9.7 X 14.4 X 25.5 (BRASS)	595	P0797595	DOWEL PIN 5 X 20
528	P0797528	CLUSTER COMBO GEAR 32T	596	P0797596	OVERLOAD CLUTCH TRIP LEVER
529	P0797529	KEY 3 X 3 X 45	597	P0797597	CLUTCH WASHER 10 X 3 X 22MM
531	P0797531	CLUSTER GEAR SHAFT	598	P0797598	EXT RETAINING RING 10MM
532	P0797532	EXT RETAINING RING 16MM	599	P0797599	CLUTCH ARM COVER
533	P0797533	SLEEVE BEARING 16 X 13.5 X 24 (BRASS)	600	P0797600	SET SCREW M6-1 X 16
534	P0797534	BEVEL GEAR THRUST WASHER 8MM	601	P0797601	HEX NUT M6-1
535	P0797535	FEED REVERSE BEVEL PINION	603	P0797603	CAM ROD
536	P0797536	FEED DRIVE GEAR 32T	604	P0797604	LEVER SHAFT M5-.8 X 4, M5-.8 X 4, L84
537	P0797537	KEY 3 X 3 X 8	605	P0797605	BALL KNOB 25MM, M6-1 BLK
538	P0797538	CLUSTER GEAR INPUT SHAFT	606	P0797606	FEED TRIP BRACKET
540	P0797540	FEED DRIVE GEAR 27T	607	P0797607	CAP SCREW M6-1 X 20
541	P0797541	NEEDLE BEARING BA66	608	P0797608	SET SCREW M6-1 X 20
542	P0797542	BUSHING	610	P0797610	SHOULDER SCREW M4-.7 X 9 GROOVED
543	P0797543	FEED WORM	611	P0797611	FEED REVERSE KNOB
544	P0797544	FEED WORM SHAFT BUSHING	612	P0797612	EXT RETAINING RING 12MM
547	P0797547	FEED WORM SHAFT THRUST WASHER	613	P0797613	HANDWHEEL CLUTCH
548	P0797548	BUSHING	614	P0797614	STEEL BALL 3/16
549	P0797549	FEED REVERSE BEVEL GEAR 35T	615	P0797615	COMPRESSION SPRING
550	P0797550	FEED REVERSE CLUTCH	616	P0797616	SET SCREW M8-1.25 X 8
551	P0797551	FEED REVERSE BEVEL GEAR 30T	617	P0797617	ROLL PIN 3 X 14
552	P0797552	BUSHING	618	P0797618	CAM ROD SLEEVE ASSEMBLY
555	P0797555	REVERSE CLUTCH ROD	619	P0797619	ROLL PIN 3 X 12
556	P0797556	ROLL PIN 3 X 20	620	P0797620	COMPRESSION SPRING
557	P0797557	FEED WORM SHAFT	621	P0797621	TRIP PLUNGER
559	P0797559	ROLL PIN 3 X 12	623	P0797623	PLUNGER BUSHING
560	P0797560	FEED SHAFT ROD	624	P0797624	FEED TRIP PLUNGER
561	P0797561	SET SCREW M5-.8 X 6	625	P0797625	HANDWHEEL 138D X 13B X M8-1.25 DISHED
562	P0797562	KEY 3 X 3 X 15	626	P0797626	HANDWHEEL HANDLE 66L, M8-1.25 X 10
563	P0797563	FEED GEAR SHIFT CRANK	627	P0797627	R-8 SPINDLE
564	P0797564	CLUSTER GEAR SHIFT CRANK	628	P0797628	QUILL SKIRT



# G0797 Downfeed Parts List (Cont.)

REF PART #	DESCRIPTION
629	P0797629 SPANNER NUT M30-1.5
630	P0797630 EXT TOOTH WASHER 30MM
631	P0797631 BALL BEARING 6206ZZ
633	P0797633 QUILL NOSE PIECE
634	P0797634 LOWER SPINDLE SEAL 64 X 35MM
635	P0797635 ANGULAR CONTACT BEARING 7207
636	P0797636 BEARING SPACER (LARGE)
637	P0797637 BEARING SPACER (SMALL)
638	P0797638 ANGULAR CONTACT BEARING 7207
640	P0797640 SPINDLE SET SCREW M5-.8 X 5
641	P0797641 SET SCREW M6-1 X 6
642	P0797642 QUILL
643	P0797643 HEX NUT M4-.7
644	P0797644 SET SCREW M4-.7 X 16
645	P0797645 FEED TRIP LEVER
646	P0797646 TRIP LEVER PIN
648	P0797648 QUILL LOCK SLEEVE
649	P0797649 ADJUSTABLE HANDLE
652	P0797652 QUICK LOCK BOLT M8-1.25 X 100
653	P0797653 QUILL LOCK SLEEVE M8-1.25
655	P0797655 T-BOLT 1/2-13 X 10"
656	P0797656 SPACER
657	P0797657 HEX CAP NUT 1/2-13 X 1.5"
658	P0797658 PHLP HD SCR M4-.7 X 6
659	P0797659 DOWNFEED MICROMETER SCALE
660	P0797660 EXT RETAINING RING 15MM
661	P0797661 QUILL DEPTH STOP NUT
662	P0797662 MICROMETER NUT
663	P0797663 QUILL STOP KNOB

REF PART #	DESCRIPTION
664	P0797664 QUILL DEPTH STOP LEADSCREW M13-1 X 160
665	P0797665 CAP SCREW M10-1 X 15
666	P0797666 QUILL PINION SHAFT
668	P0797668 ROLL PIN 3 X 8
669	P0797669 CAP SCREW M5-.8 X 10
670	P0797670 ROLL PIN 3 X 20
671	P0797671 KEY 3 X 3 X 20
672	P0797672 PINION SHAFT HUB SCREW M3-.5 X 20
673	P0797673 STEEL BALL 3/16
674	P0797674 COMPRESSION SPRING
675	P0797675 RACK FEED HANDLE HUB
676	P0797676 PINION SHAFT HUB
677	P0797677 SPRING COVER
678	P0797678 FLAT COIL SPRING
681	P0797681 SET SCREW M4-.7 X 10
682	P0797682 SET SCREW M4-.7 X 6
683	P0797683 REVERSE TRIP LEVER
684	P0797684 FEED REVERSE TRIP PLUNGER
685	P0797685 REVERSE/TRIP LEVER SCREW M8-1.25 X 10
686	P0797686 WORM GEAR
687	P0797687 KEY 4 X 4 X 8
688	P0797688 SET SCREW M3-.5 X 8
689	P0797689 ADJUSTABLE WORM SHAFT
690	P0797690 STUD-UDE M9-1.25 X 10, M11-1.5 X 10, 190L
691	P0797691 BALL KNOB 32MM, M9-1.25 BLK
692	P0797692 QUILL HOUSING
693	P0797693 EXT RETAINING RING 30MM
694	P0797694 FLAT WASHER 12MM



# G0797 One Shot Oiler

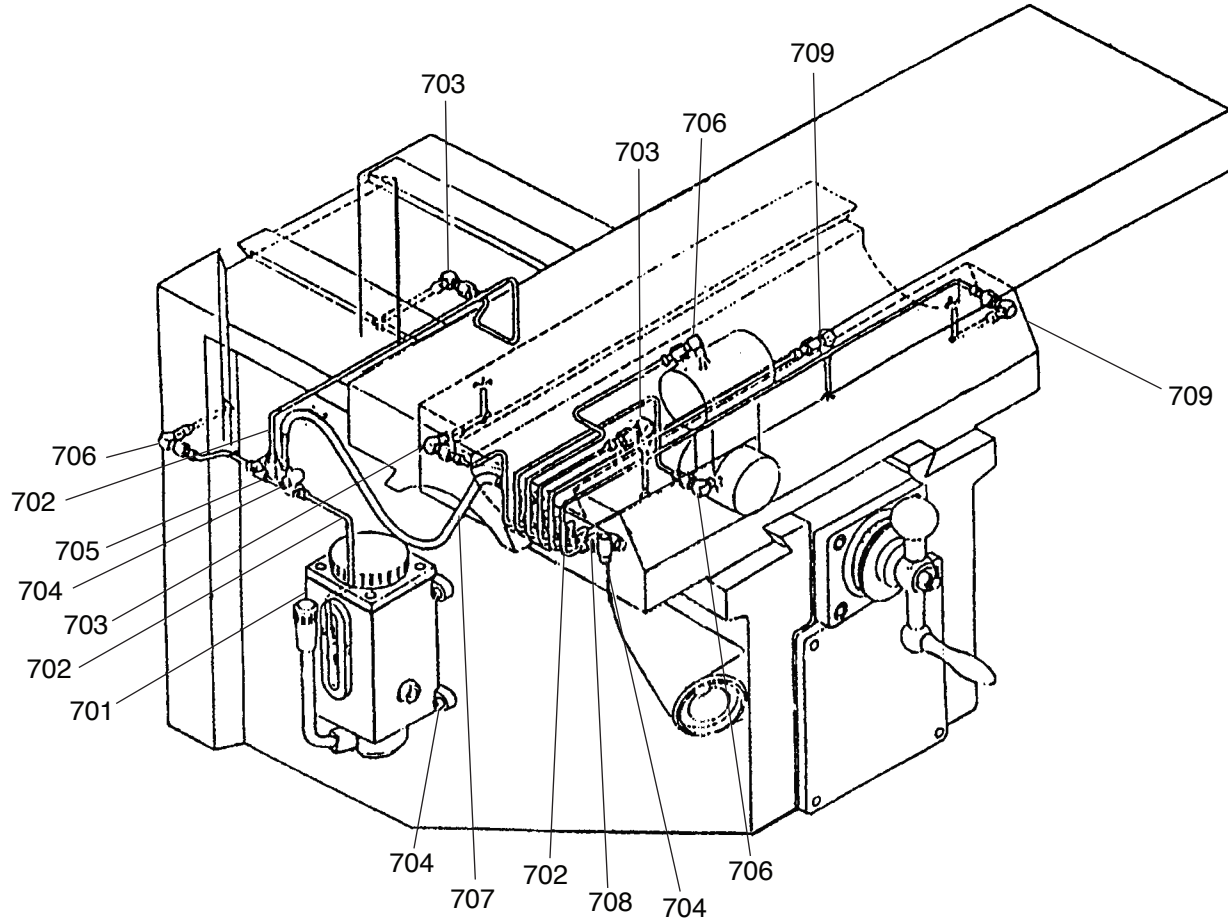

REF	PART #	DESCRIPTION
701	P0797701	OILER PUMP AND RESERVOIR 500CC
702	P0797702	ALUMINUM PIPE
703	P0797703	ELBOW OIL DISTRIBUTOR CPS4
704	P0797704	CAP SCREW M6-1 X 12
705	P0797705	A-TYPE OIL DISTRIBUTOR A4

REF	PART #	DESCRIPTION
706	P0797706	ELBOW OIL DISTRIBUTOR CPS3
707	P0797707	FLEXIBLE STEEL TUBE
708	P0797708	A-TYPE OIL DISTRIBUTOR A8
709	P0797709	ELBOW OIL DISTRIBUTOR CPS5



# G0797 Accessories

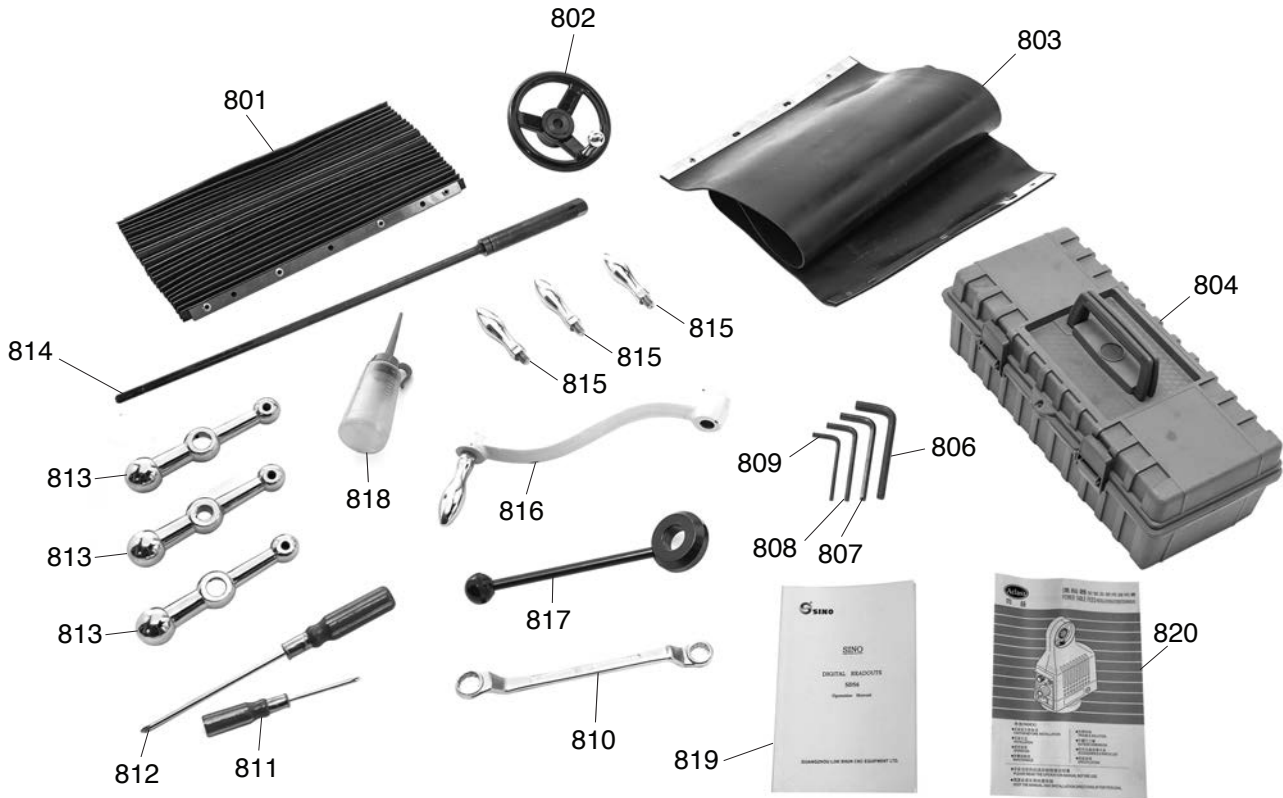

## REF PART # DESCRIPTION

801	P0797801	FRONT WAY COVER
802	P0797802	HANDWHEEL D138 X B13 X M8-1.25 DISHED
803	P0797803	REAR WAY COVER
804	P0797804	TOOLBOX
806	P0797806	HEX WRENCH 8MM
807	P0797807	HEX WRENCH 6MM
808	P0797808	HEX WRENCH 5MM
809	P0797809	HEX WRENCH 4MM
810	P0797810	CLOSED-END WRENCH 17 X 19MM
811	P0797811	SCREWDRIVER PHILLIPS #2

## REF PART # DESCRIPTION

812	P0797812	SCREWDRIVER PHILLIPS #2 EXTRA LONG
813	P0797813	BALL HANDLE
814	P0797814	DRAWBAR
815	P0797815	REVOLVING HANDLE 98L, M10-1.5 X 13
816	P0797816	Z-AXIS CRANK
817	P0797817	COARSE DOWNFEED LEVER
818	P0797818	BOTTLE FOR OIL
819	P0797819	DRO INSTRUCTIONS
820	P0797820	POWER FEED INSTRUCTIONS



# G0797 Labels & Cosmetics

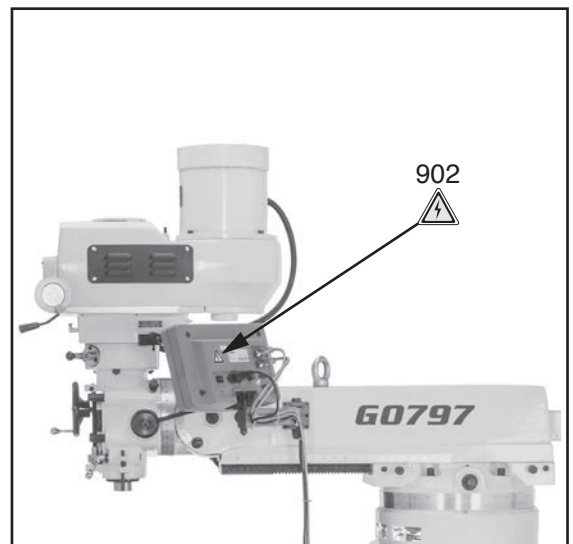
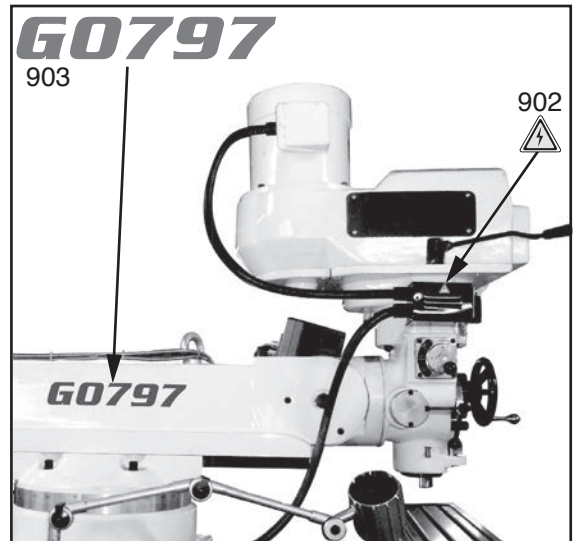
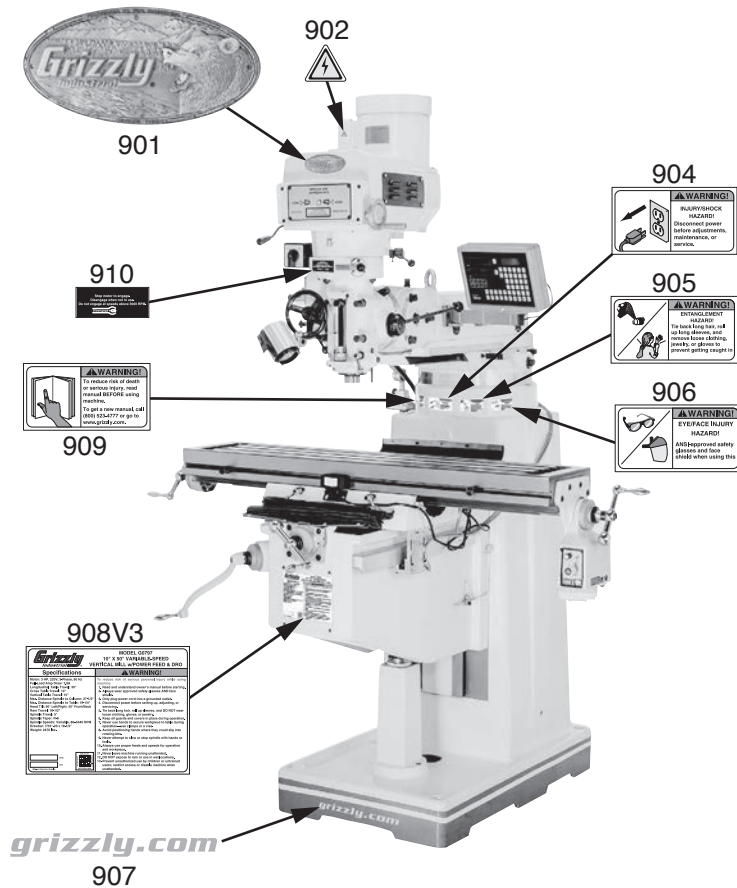

REF	PART #	DESCRIPTION
901	P0797901	GRIZZLY NAMEPLATE
902	P0797902	ELECTRICITY LABEL
903	P0797903	MODEL NUMBER LABEL
904	P0797904	DISCONNECT POWER LABEL
905	P0797905	ENTANGLEMENT HAZARD LABEL

REF	PART #	DESCRIPTION
906	P0797906	EYE/FACE INJURY HAZARD LABEL
907	P0797907	GRIZZLY.COM LABEL
908V3	P0797908V3	MACHINE ID LABEL V3.08.18
909	P0797909	READ MANUAL LABEL
910	P0797910	QUILL FEED LABEL

## WARNING

Safety labels help reduce the risk of serious injury caused by machine hazards. If any label comes off or becomes unreadable, the owner of this machine **MUST** replace it in the original location before resuming operations. For replacements, contact (800) 523-4777 or [www.grizzly.com](http://www.grizzly.com).









# WARRANTY & RETURNS

---

Grizzly Industrial, Inc. warrants every product it sells for a period of **1 year** to the original purchaser from the date of purchase. This warranty does not apply to defects due directly or indirectly to misuse, abuse, negligence, accidents, repairs or alterations or lack of maintenance. This is Grizzly's sole written warranty and any and all warranties that may be implied by law, including any merchantability or fitness, for any particular purpose, are hereby limited to the duration of this written warranty. We do not warrant or represent that the merchandise complies with the provisions of any law or acts unless the manufacturer so warrants. In no event shall Grizzly's liability under this warranty exceed the purchase price paid for the product and any legal actions brought against Grizzly shall be tried in the State of Washington, County of Whatcom.

We shall in no event be liable for death, injuries to persons or property or for incidental, contingent, special, or consequential damages arising from the use of our products.

The manufacturers reserve the right to change specifications at any time because they constantly strive to achieve better quality equipment. We make every effort to ensure that our products meet high quality and durability standards and we hope you never need to use this warranty.

In the event you need to use this warranty, contact us by mail or phone and give us all the details. We will then issue you a "Return Number," which must be clearly posted on the outside as well as the inside of the carton. We will not accept any item back without this number. Proof of purchase must accompany the merchandise.

Please feel free to write or call us if you have any questions about the machine or the manual.

Thank you again for your business and continued support. We hope to serve you again soon.

To take advantage of this warranty, you must register it at <https://www.grizzly.com/forms/warranty>, or you can scan the QR code below to be automatically directed to our warranty registration page. Enter all applicable information for the product.



# *grizzly.com*<sup>®</sup>

**TOOL WEBSITE**

Buy Direct and Save with Grizzly<sup>®</sup> – Trusted, Proven and a Great Value!  
~Since 1983~

*Visit Our Website Today For  
Current Specials!*

**ORDER  
24 HOURS A DAY!  
1-800-523-4777**

