

READ THIS FIRST



Model G0792

*****IMPORTANT UPDATE*****

**For Machines Mfd. Since 04/18
and Owner's Manual Revised 03/16**

For questions or help with this product contact Tech Support at (570) 546-9663 or techsupport@grizzly.com

The following changes were recently made since the owner's manual was printed:

- The motor changed.
- The start capacitor changed.

Aside from this information, all other content in the owner's manual applies and **MUST** be read and understood for your own safety. **IMPORTANT: Keep this update with the owner's manual for future reference.**

For questions or help, contact our Tech Support at (570) 546-9663 or techsupport@grizzly.com.

Revised Parts

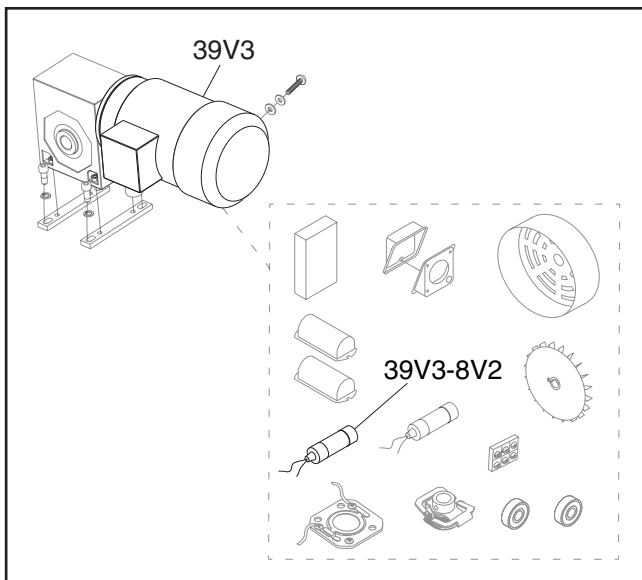

Revised Specifications

Electrical:

Full-Load Current Rating..... 10A

Motor:

Amps 10A

| REF | PART # | DESCRIPTION |
|----------|----------------|--|
| 39V3 | P0792039V3 | MOTOR 2HP 220V 1-PH V3.04.18 |
| 39V3-8V2 | P0792039V3-8V2 | S CAPACITOR 100M 275V 1-5/8 X 3-3/8 V3.04.22 |

COPYRIGHT © MAY, 2022 BY GRIZZLY INDUSTRIAL, INC.
**WARNING: NO PORTION OF THIS MANUAL MAY BE REPRODUCED IN ANY SHAPE
OR FORM WITHOUT THE WRITTEN APPROVAL OF GRIZZLY INDUSTRIAL, INC.**
#SS22340 PRINTED IN CHINA

Electrical Components

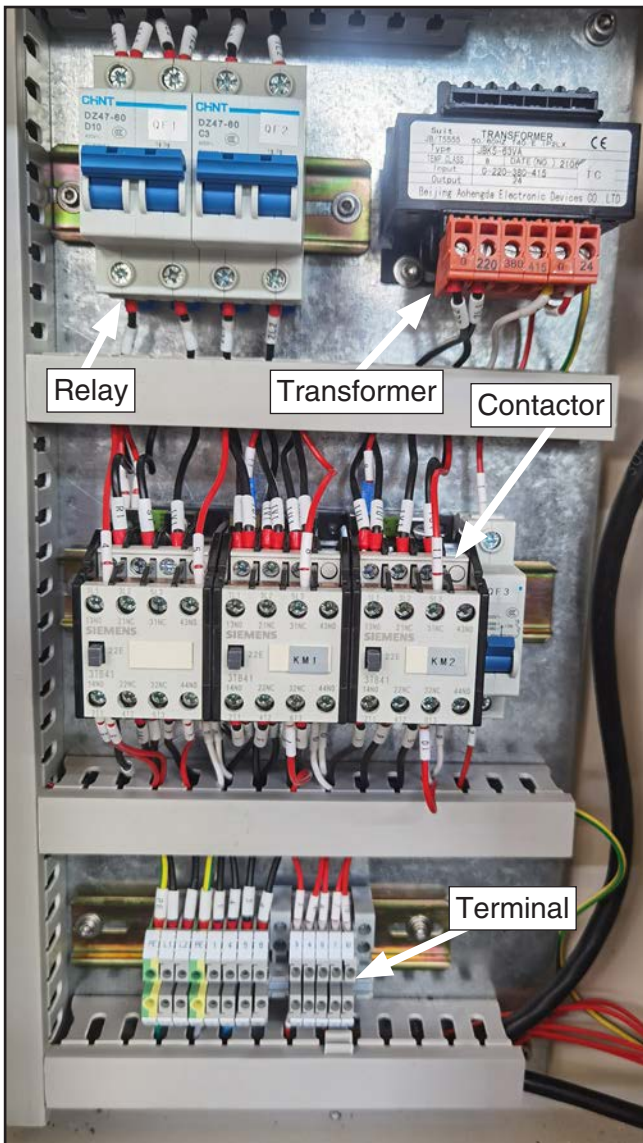

Figure 30. Electrical cabinet components.



Figure 31. Foot pedal wiring.

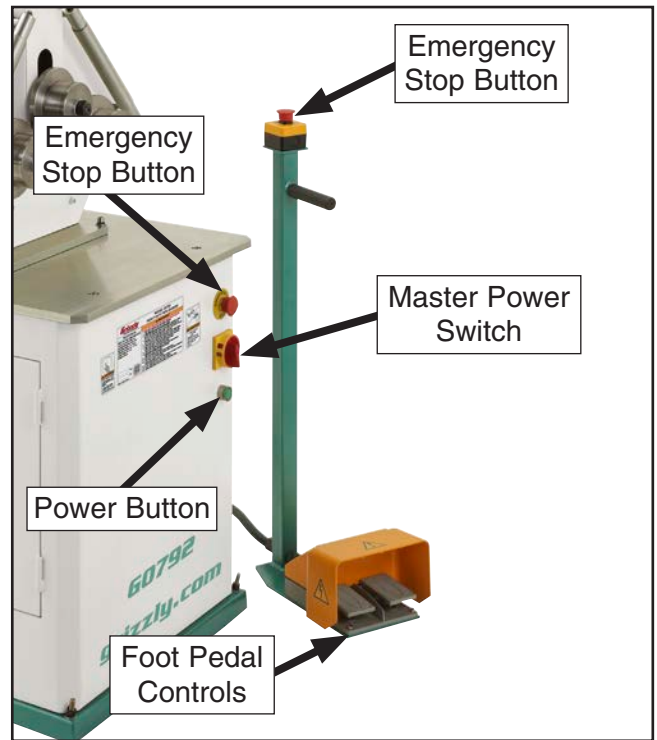

Figure 32. Foot pedal assembly, emergency stop button, and forward-facing controls.



Figure 33. Motor junction box and starting switch.



Electrical Panel Wiring Diagram

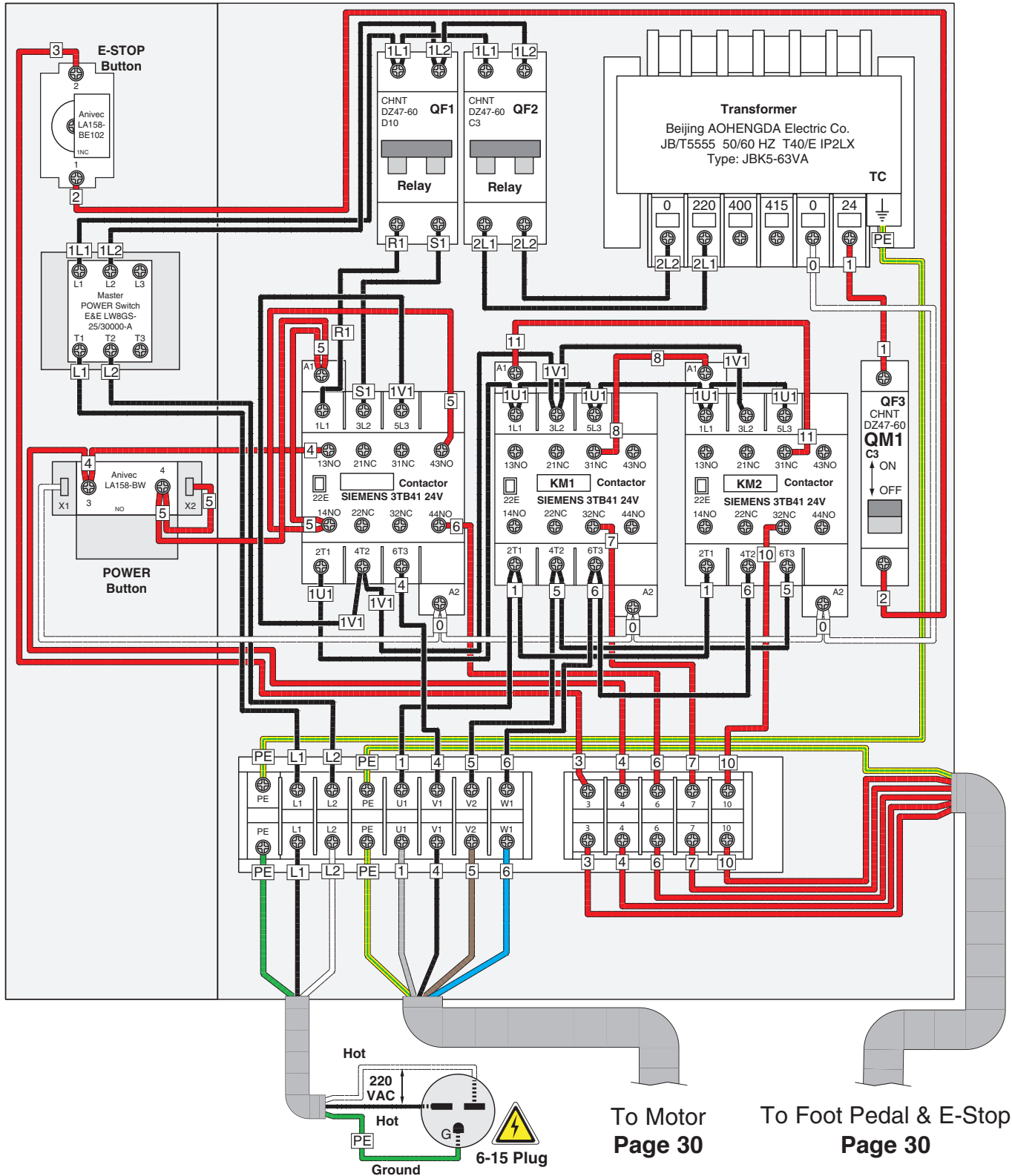

Motor Diagram

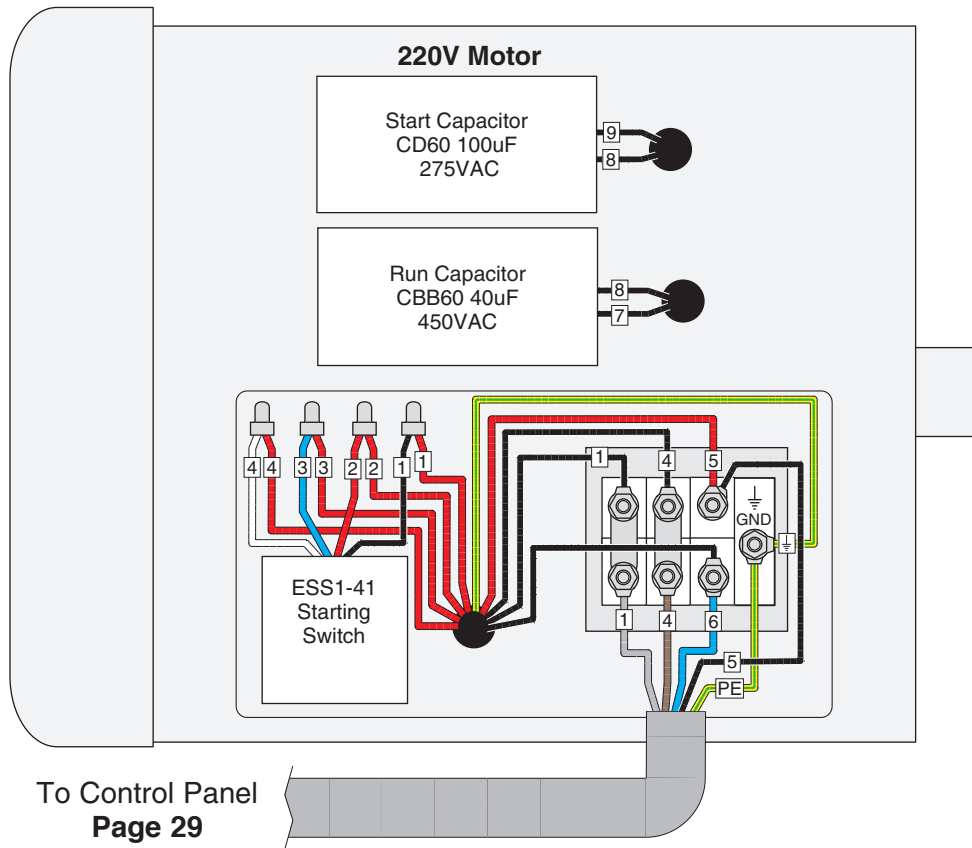

Foot Pedal & E-Stop Diagram

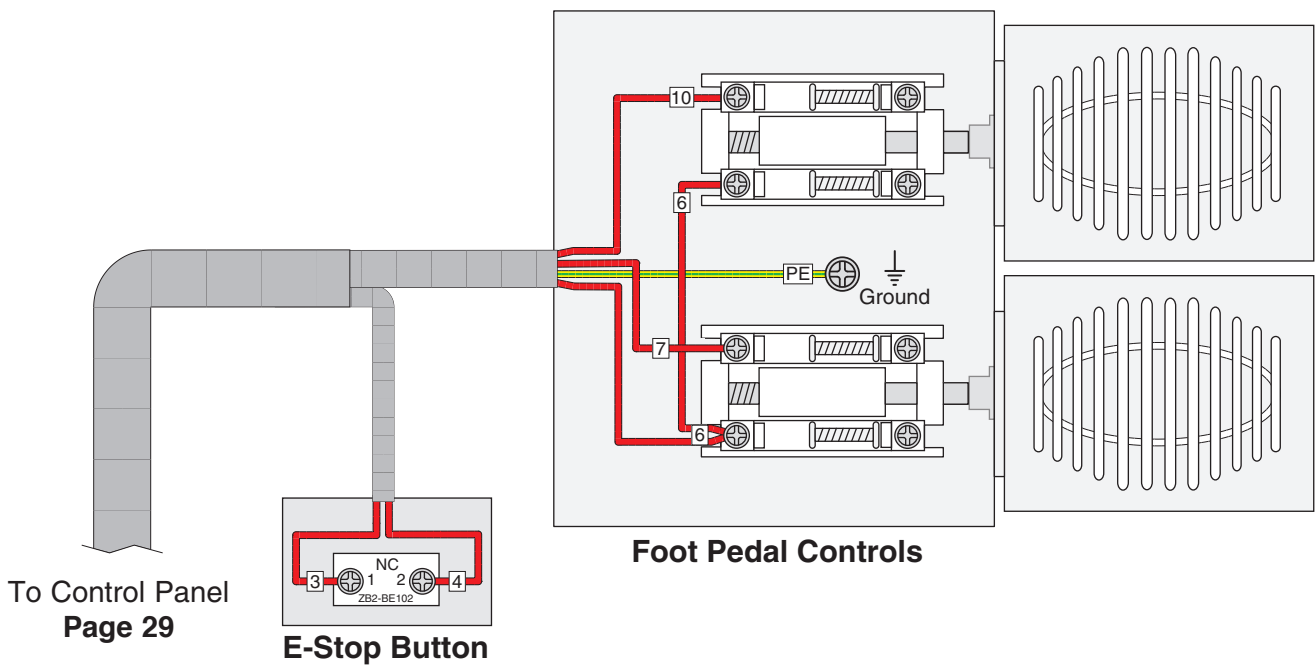

Grizzly **Industrial, Inc.**®

MODEL G0792 **HEAVY-DUTY RING ROLL PIPE BENDER** **OWNER'S MANUAL** *(For models manufactured since 12/15)*



COPYRIGHT © NOVEMBER, 2015 BY GRIZZLY INDUSTRIAL, INC., REVISED MARCH, 2016 (MN)
**WARNING: NO PORTION OF THIS MANUAL MAY BE REPRODUCED IN ANY SHAPE
OR FORM WITHOUT THE WRITTEN APPROVAL OF GRIZZLY INDUSTRIAL, INC.**
#WK17572 PRINTED IN CHINA

V3.03.16



WARNING!

This manual provides critical safety instructions on the proper setup, operation, maintenance, and service of this machine/tool. Save this document, refer to it often, and use it to instruct other operators.

Failure to read, understand and follow the instructions in this manual may result in fire or serious personal injury—including amputation, electrocution, or death.

The owner of this machine/tool is solely responsible for its safe use. This responsibility includes but is not limited to proper installation in a safe environment, personnel training and usage authorization, proper inspection and maintenance, manual availability and comprehension, application of safety devices, cutting/sanding/grinding tool integrity, and the usage of personal protective equipment.

The manufacturer will not be held liable for injury or property damage from negligence, improper training, machine modifications or misuse.



WARNING!

Some dust created by power sanding, sawing, grinding, drilling, and other construction activities contains chemicals known to the State of California to cause cancer, birth defects or other reproductive harm. Some examples of these chemicals are:

- **Lead from lead-based paints.**
- **Crystalline silica from bricks, cement and other masonry products.**
- **Arsenic and chromium from chemically-treated lumber.**

Your risk from these exposures varies, depending on how often you do this type of work. To reduce your exposure to these chemicals: Work in a well ventilated area, and work with approved safety equipment, such as those dust masks that are specially designed to filter out microscopic particles.

Table of Contents

- INTRODUCTION..... 2**
 - Contact Info..... 2
 - Manual Accuracy..... 2
 - Identification 3
 - Controls & Components 4
 - Machine Data Sheet..... 5

- SECTION 1: SAFETY 6**
 - Safety Instructions for Machinery..... 6
 - Additional Safety for Ring Roll Benders..... 8

- SECTION 2: POWER SUPPLY 9**

- SECTION 3: SETUP 11**
 - Unpacking 11
 - Needed for Setup 11
 - Inventory..... 11
 - Cleanup..... 12
 - Site Considerations 13
 - Assembly..... 14
 - Lifting & Placing 14
 - Anchoring to Floor..... 15
 - Test Run..... 16

- SECTION 4: OPERATIONS 17**
 - Operation Overview..... 17
 - Rolling Arcs 18
 - Rolling Compound Arcs 20

- SECTION 5: ACCESSORIES 22**

- SECTION 6: MAINTENANCE..... 23**
 - Schedule 23
 - Cleaning & Protecting 23
 - Lubrication..... 23

- SECTION 7: SERVICE 25**
 - Troubleshooting..... 25

- SECTION 8: WIRING..... 27**
 - Wiring Safety Instructions 27
 - Electrical Components 28
 - Electrical Panel Wiring Diagram..... 29
 - Motor Diagram..... 30
 - Foot Pedal & E-Stop Diagram..... 30

- SECTION 9: PARTS..... 31**
 - Main..... 31
 - Electrical Panel..... 33
 - Labels & Cosmetics 34

- WARRANTY & RETURNS 37**

INTRODUCTION

Contact Info

We stand behind our machines! If you have questions or need help, contact us with the information below. Before contacting, make sure you get the **serial number** and **manufacture date** from the machine ID label. This will help us help you faster.

Grizzly Technical Support
1815 W. Battlefield
Springfield, MO 65807
Phone: (570) 546-9663
Email: techsupport@grizzly.com

We want your feedback on this manual. What did you like about it? Where could it be improved? Please take a few minutes to give us feedback.

Grizzly Documentation Manager
P.O. Box 2069
Bellingham, WA 98227-2069
Email: manuals@grizzly.com

Manual Accuracy

We are proud to provide a high-quality owner's manual with your new machine!

We made every effort to be exact with the instructions, specifications, drawings, and photographs in this manual. Sometimes we make mistakes, but our policy of continuous improvement also means that **sometimes the machine you receive is slightly different than shown in the manual.**

If you find this to be the case, and the difference between the manual and machine leaves you confused or unsure about something, check our website for an updated version. We post current manuals and manual updates for free on our website at www.grizzly.com.

Alternatively, you can call our Technical Support for help. Before calling, make sure you write down the **Manufacture Date** and **Serial Number** from the machine ID label (see below). This information is required for us to provide proper tech support, and it helps us determine if updated documentation is available for your machine.

| | | | |
|--|--|-----------------------------|--|
|  | | MODEL GXXXX MACHINE NAME | |
| SPECIFICATIONS | | ▲ WARNING! | |
| Motor: | To reduce risk of serious injury when using this machine: | | |
| Specification: | Read manual before operation. | | |
| Specification: | Wear safety glasses and respirator. | | |
| Specification: | Ensure safety is correctly adjusted/setup and | | |
| Specification: | power is connected to grounded circuit before starting. | | |
| Weight: | 4. Make sure the motor has stopped and disconnect | | |
| | power before adjustments, maintenance, or service. | | |
| | 5. DO NOT expose to rain or dampness. | | |
| | 6. DO NOT modify this machine in any way. | | |
| | 7. | | |
| | 8. | | |
| | 9. Do not use while under the influence of drugs or alcohol. | | |
| | 10. Maintain machine carefully to prevent accidents. | | |
| Manufactured for Grizzly in Taiwan | | | |

Manufacture Date

Serial Number



Identification

Become familiar with the names and locations of the controls and features shown below to better understand the instructions in this manual.

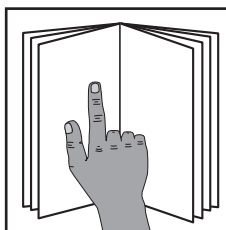
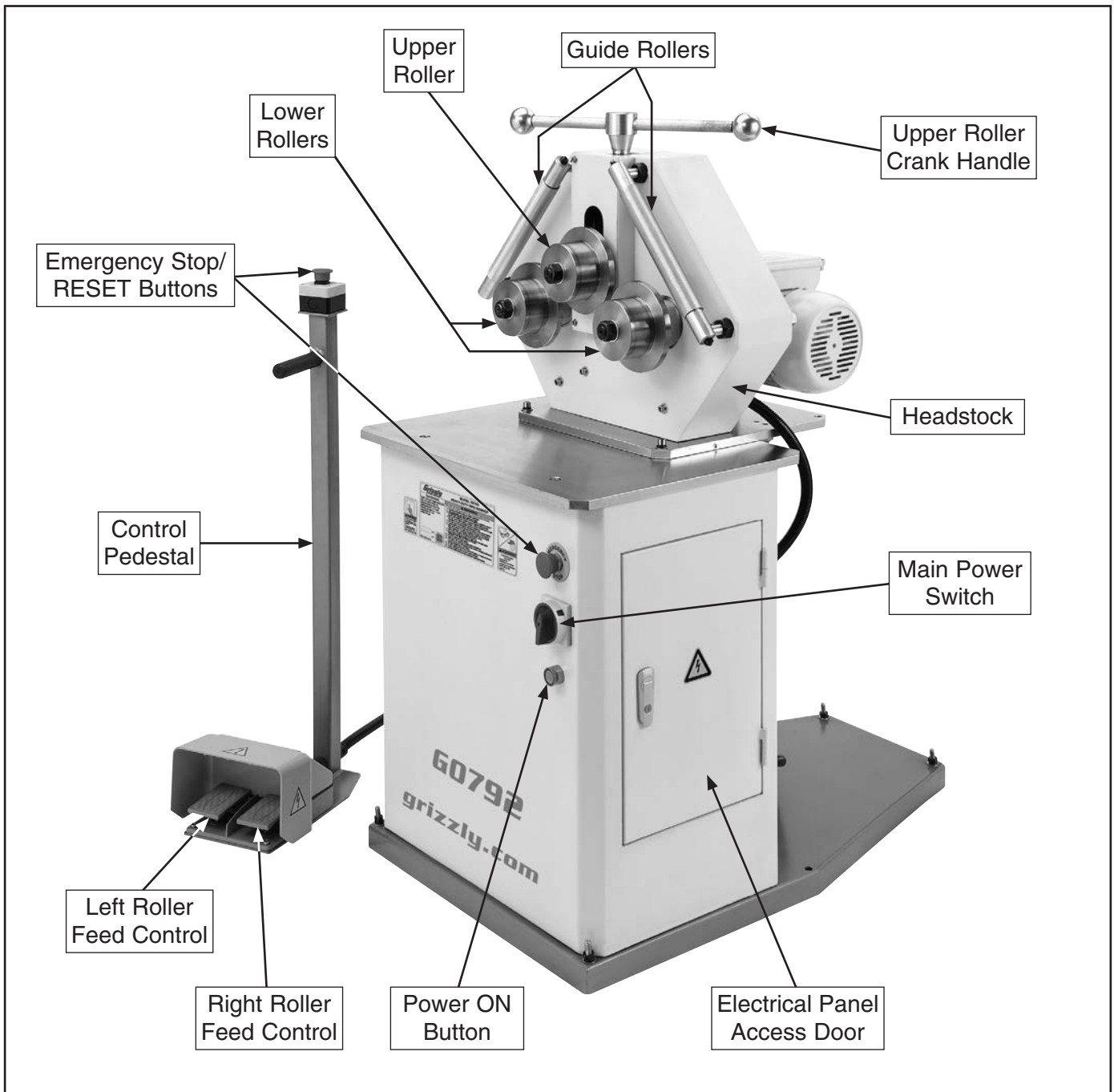

! WARNING

To reduce your risk of serious injury, read this entire manual **BEFORE** using machine.



Controls & Components



Refer to **Figures 1 & 2** and the following descriptions to become familiar with the basic controls and components of this machine. Understanding these items and how they work will help you understand the rest of the manual and stay safe when operating this machine.

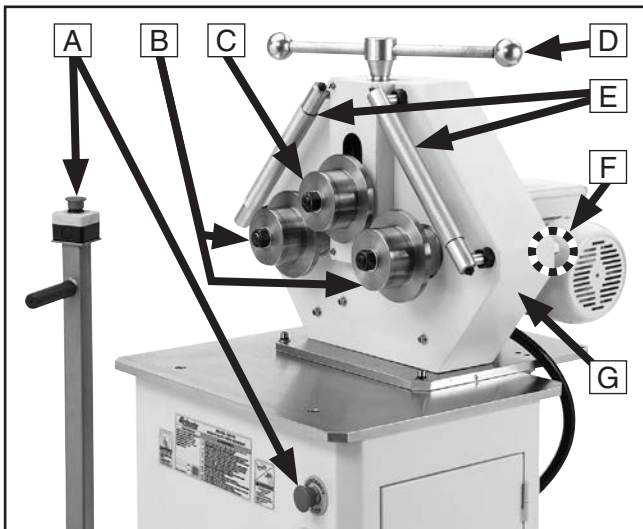

Figure 1. Upper controls and components.

- A. Emergency Stop/RESET Buttons (2):** Stop all machine functions when pressed. Twist clockwise to reset.
- B. Lower Rollers (2):** Rotate to feed workpiece through headstock.
- C. Upper Roller:** Presses workpiece against lower rollers to create bend. Adjusts toward or away from lower rollers depending on workpiece dimensions and desired radius.
- D. Upper Roller Crank Handle:** Adjusts position of upper roller relative to lower rollers. Moving upper roller closer to lower rollers increases bend in workpiece.

- E. Guide Rollers (2):** Used to correct or create a twist in workpiece.
- F. Guide Roller Adjustment Bolts (4):** Rotate to adjust guide roller positions.
- G. Headstock:** Houses motor, drive gears, and bending components (**B–E**). Can be adjusted to vertical or horizontal bending positions.

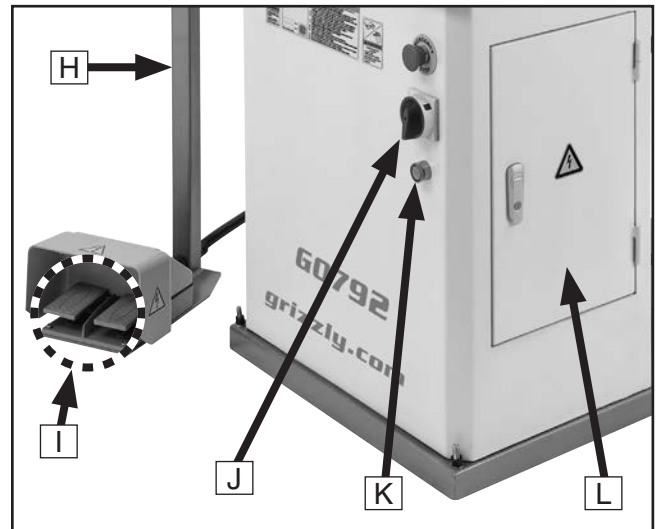

Figure 2. Lower controls and components.

- H. Control Pedestal:** Allows user to control machine while standing away from moving parts and workpiece.
- I. Foot Pedal Feed Controls:** When pressed, cause rollers to feed workpiece to left or right (as viewed when facing front of machine). When released, rollers stop.
- J. Main Power Switch:** Toggles incoming power ON or OFF.
- K. Power ON Button:** Enables power to machine components. Illuminates when energized.
- L. Electrical Panel Access Door:** Opens for access to electrical panel.





MACHINE DATA SHEET

© Grizzly Industrial, Inc. • Customer Service: (800) 523-4777 • Tech Support: (570) 546-9663

MODEL G0792 HEAVY-DUTY RING ROLL PIPE BENDER

Product Dimensions:

Weight 583 lbs.
 Width (side-to-side) x Depth (front-to-back) x Height 29 x 40 x 51 in.
 Foot Print (Length/Width)..... 40 x 24-1/2 in.

Shipping Dimensions:

Type Wood Crate
 Weight..... 626 lbs.
 Length/Width/Height..... 44 x 27 x 48 in.

Electrical:

Power Requirement 220V, Single-Phase, 60 Hz
 Prewired Voltage..... 220V
 Full-Load Current Rating 8.6A
 Minimum Circuit Size 15A
 Connection Type..... Cord & Plug
 Power Cord Included Yes
 Power Cord Length 6-1/2 ft.
 Power Cord Gauge 14 AWG
 Plug Included No
 Recommended Plug Type 6-15
 Switch Type Push Button, E-Stop
 Switch Voltage 220V

Motor:

Type TEFC Capacitor-Start Induction
 Horsepower..... 2 HP
 Phase Single-Phase
 Amps 8.6A
 Speed..... 1720 RPM
 Power Transfer Gear Drive
 Bearings Shielded & Permanently Lubricated

Main Specifications:

Capacities

Square Mild Steel 1-9/16 x 1-9/16 x 1/16 in.
 C-Channel Mild Steel 2 x 1 x 1/8 in.

Operation Information

Minimum Outer Radius..... 11-3/4 in.
 Maximum Bending Speed 14.8 FPM
 No. of Driven Rolls 2
 Control Method..... Electric
 Vertical Travel of Upper Shaft..... 3-1/2 in.



SECTION 1: SAFETY

For Your Own Safety, Read Instruction Manual Before Operating This Machine

The purpose of safety symbols is to attract your attention to possible hazardous conditions. This manual uses a series of symbols and signal words intended to convey the level of importance of the safety messages. The progression of symbols is described below. Remember that safety messages by themselves do not eliminate danger and are not a substitute for proper accident prevention measures. Always use common sense and good judgment.

 **DANGER** Indicates an imminently hazardous situation which, if not avoided, **WILL** result in death or serious injury.

 **WARNING** Indicates a potentially hazardous situation which, if not avoided, **COULD** result in death or serious injury.

 **CAUTION** Indicates a potentially hazardous situation which, if not avoided, **MAY** result in minor or moderate injury. It may also be used to alert against unsafe practices.

NOTICE This symbol is used to alert the user to useful information about proper operation of the machine.

Safety Instructions for Machinery

WARNING

OWNER'S MANUAL. Read and understand this owner's manual **BEFORE** using machine.

TRAINED OPERATORS ONLY. Untrained operators have a higher risk of being hurt or killed. Only allow trained/supervised people to use this machine. When machine is not being used, disconnect power, remove switch keys, or lock-out machine to prevent unauthorized use—especially around children. Make workshop kid proof!

DANGEROUS ENVIRONMENTS. Do not use machinery in areas that are wet, cluttered, or have poor lighting. Operating machinery in these areas greatly increases the risk of accidents and injury.

MENTAL ALERTNESS REQUIRED. Full mental alertness is required for safe operation of machinery. Never operate under the influence of drugs or alcohol, when tired, or when distracted.

ELECTRICAL EQUIPMENT INJURY RISKS. You can be shocked, burned, or killed by touching live electrical components or improperly grounded machinery. To reduce this risk, only allow qualified service personnel to do electrical installation or repair work, and always disconnect power before accessing or exposing electrical equipment.

DISCONNECT POWER FIRST. Always disconnect machine from power supply **BEFORE** making adjustments, changing tooling, or servicing machine. This prevents an injury risk from unintended startup or contact with live electrical components.

EYE PROTECTION. Always wear ANSI-approved safety glasses or a face shield when operating or observing machinery to reduce the risk of eye injury or blindness from flying particles. Everyday eyeglasses are **NOT** approved safety glasses.



WARNING

WEARING PROPER APPAREL. Do not wear clothing, apparel or jewelry that can become entangled in moving parts. Always tie back or cover long hair. Wear non-slip footwear to reduce risk of slipping and losing control or accidentally contacting cutting tool or moving parts.

HAZARDOUS DUST. Dust created by machinery operations may cause cancer, birth defects, or long-term respiratory damage. Be aware of dust hazards associated with each workpiece material. Always wear a NIOSH-approved respirator to reduce your risk.

HEARING PROTECTION. Always wear hearing protection when operating or observing loud machinery. Extended exposure to this noise without hearing protection can cause permanent hearing loss.

REMOVE ADJUSTING TOOLS. Tools left on machinery can become dangerous projectiles upon startup. Never leave chuck keys, wrenches, or any other tools on machine. Always verify removal before starting!

USE CORRECT TOOL FOR THE JOB. Only use this tool for its intended purpose—do not force it or an attachment to do a job for which it was not designed. Never make unapproved modifications—modifying tool or using it differently than intended may result in malfunction or mechanical failure that can lead to personal injury or death!

AWKWARD POSITIONS. Keep proper footing and balance at all times when operating machine. Do not overreach! Avoid awkward hand positions that make workpiece control difficult or increase the risk of accidental injury.

CHILDREN & BYSTANDERS. Keep children and bystanders at a safe distance from the work area. Stop using machine if they become a distraction.

GUARDS & COVERS. Guards and covers reduce accidental contact with moving parts or flying debris. Make sure they are properly installed, undamaged, and working correctly **BEFORE** operating machine.

FORCING MACHINERY. Do not force machine. It will do the job safer and better at the rate for which it was designed.

NEVER STAND ON MACHINE. Serious injury may occur if machine is tipped or if the cutting tool is unintentionally contacted.

STABLE MACHINE. Unexpected movement during operation greatly increases risk of injury or loss of control. Before starting, verify machine is stable and mobile base (if used) is locked.

USE RECOMMENDED ACCESSORIES. Consult this owner's manual or the manufacturer for recommended accessories. Using improper accessories will increase the risk of serious injury.

UNATTENDED OPERATION. To reduce the risk of accidental injury, turn machine **OFF** and ensure all moving parts completely stop before walking away. Never leave machine running while unattended.

MAINTAIN WITH CARE. Follow all maintenance instructions and lubrication schedules to keep machine in good working condition. A machine that is improperly maintained could malfunction, leading to serious personal injury or death.

DAMAGED PARTS. Regularly inspect machine for damaged, loose, or mis-adjusted parts—or any condition that could affect safe operation. Immediately repair/replace **BEFORE** operating machine. For your own safety, **DO NOT** operate machine with damaged parts!

MAINTAIN POWER CORDS. When disconnecting cord-connected machines from power, grab and pull the plug—**NOT** the cord. Pulling the cord may damage the wires inside. Do not handle cord/plug with wet hands. Avoid cord damage by keeping it away from heated surfaces, high traffic areas, harsh chemicals, and wet/damp locations.

EXPERIENCING DIFFICULTIES. If at any time you experience difficulties performing the intended operation, stop using the machine! Contact our Technical Support at (570) 546-9663.



Additional Safety for Ring Roll Benders

WARNING

Serious injury or death can occur from fingers, clothing, jewelry, or hair becoming entangled/ crushed in rotating or moving parts. Workpieces not seated properly on rollers can fall and cause crushing injury to feet. To minimize risk of injury, anyone operating this machine **MUST** completely heed hazards and warnings below.

AVOIDING ENTANGLEMENT. Becoming entangled in moving parts of this machine can cause pinching and crushing injuries. To avoid these hazards, **DO NOT** wear loose clothing, gloves, or jewelry, and tie back long hair.

HAND PLACEMENT. Holding workpiece too close to rollers during operation increases risk of pinching and crushing injuries. To reduce your risk, keep hands away from rollers during operation. **NEVER** place hands and fingers near rollers during operation.

FOOT PROTECTION. Heavy workpieces accidentally falling off of rollers during operation can cause crushing injuries to the feet of operator. To reduce your risk, wear steel-toed boots when using machine.

FEEDING WORKPIECE. Forcefully jamming workpiece through rollers could cause hands or fingers to slip and get caught in moving parts, causing pinching and crushing injuries. Only advance workpiece using foot pedals. **DO NOT** use hands to force workpiece through rollers.

USING CORRECT STOCK FOR OPERATION. Using incompatible stock with installed rollers can cause it to be ejected from machine during operation, causing personal injury or damaging workpiece or machine. Only bend material that is compatible with installed rollers.



SECTION 2: POWER SUPPLY

Availability

Before installing the machine, consider the availability and proximity of the required power supply circuit. If an existing circuit does not meet the requirements for this machine, a new circuit must be installed. To minimize the risk of electrocution, fire, or equipment damage, installation work and electrical wiring must be done by an electrician or qualified service personnel in accordance with all applicable codes and standards.

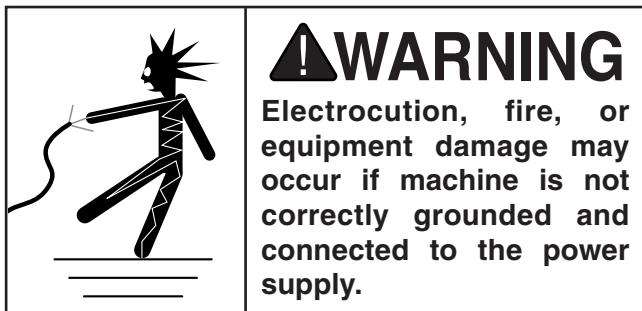

Full-Load Current Rating

The full-load current rating is the amperage a machine draws at 100% of the rated output power. On machines with multiple motors, this is the amperage drawn by the largest motor or sum of all motors and electrical devices that might operate at one time during normal operations.

Full-Load Current Rating at 220V 8.6 Amps

The full-load current is not the maximum amount of amps that the machine will draw. If the machine is overloaded, it will draw additional amps beyond the full-load rating.

If the machine is overloaded for a sufficient length of time, damage, overheating, or fire may result—especially if connected to an undersized circuit. To reduce the risk of these hazards, avoid overloading the machine during operation and make sure it is connected to a power supply circuit that meets the specified circuit requirements.

Circuit Information

A power supply circuit includes all electrical equipment between the breaker box or fuse panel in the building and the machine. The power supply circuit used for this machine must be sized to safely handle the full-load current drawn from the machine for an extended period of time. (If this machine is connected to a circuit protected by fuses, use a time delay fuse marked D.)

! CAUTION
For your own safety and protection of property, consult an electrician if you are unsure about wiring practices or electrical codes in your area.

Note: *Circuit requirements in this manual apply to a dedicated circuit—where only one machine will be running on the circuit at a time. If machine will be connected to a shared circuit where multiple machines may be running at the same time, consult an electrician or qualified service personnel to ensure circuit is properly sized for safe operation.*

Circuit Requirements

This machine is prewired to operate on a power supply circuit that has a verified ground and meets the following requirements:

Nominal Voltage 208V, 220V, 230V, 240V
Cycle 60 Hz
Phase Single-Phase
Power Supply Circuit 15 Amps
Plug/Receptacle NEMA 6-15



Grounding Requirements

This machine **MUST** be grounded. In the event of certain malfunctions or breakdowns, grounding reduces the risk of electric shock by providing a path of least resistance for electric current.

This machine is equipped with a power cord that has an equipment-grounding wire and a grounding plug. Only insert plug into a matching receptacle (outlet) that is properly installed and grounded in accordance with all local codes and ordinances. **DO NOT** modify the provided plug!

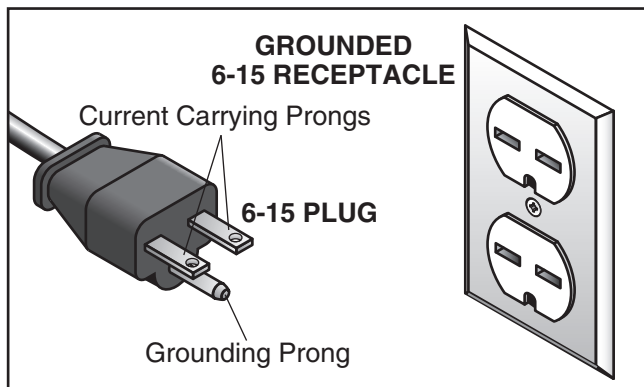
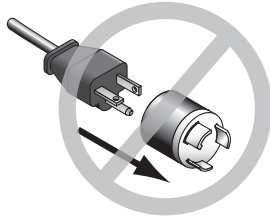

Figure 3. Typical 6-15 plug and receptacle.

CAUTION



No adapter should be used with plug. If plug does not fit available receptacle, or if machine must be reconnected for use on a different type of circuit, reconnection must be performed by an electrician or qualified service personnel, and it must comply with all local codes and ordinances.

WARNING

Serious injury could occur if you connect machine to power before completing setup process. DO NOT connect to power until instructed later in this manual.

Improper connection of the equipment-grounding wire can result in a risk of electric shock. The wire with green insulation (with or without yellow stripes) is the equipment-grounding wire. If repair or replacement of the power cord or plug is necessary, do not connect the equipment-grounding wire to a live (current carrying) terminal.

Check with a qualified electrician or service personnel if you do not understand these grounding requirements, or if you are in doubt about whether the tool is properly grounded. If you ever notice that a cord or plug is damaged or worn, disconnect it from power, and immediately replace it with a new one.

Extension Cords

We do not recommend using an extension cord with this machine. If you must use an extension cord, only use it if absolutely necessary and only on a temporary basis.

Extension cords cause voltage drop, which can damage electrical components and shorten motor life. Voltage drop increases as the extension cord size gets longer and the gauge size gets smaller (higher gauge numbers indicate smaller sizes).

Any extension cord used with this machine must be in good condition and contain a ground wire and matching plug/receptacle. Additionally, it must meet the following size requirements:

Minimum Gauge Size 14 AWG
Maximum Length (Shorter is Better).....50 ft.



SECTION 3: SETUP

Unpacking

This machine was carefully packaged for safe transport. When unpacking, separate all enclosed items from packaging materials and inspect them for shipping damage. ***If items are damaged, please call us immediately at (570) 546-9663.***

IMPORTANT: Save all packaging materials until you are completely satisfied with the machine and have resolved any issues between Grizzly or the shipping agent. ***You MUST have the original packaging to file a freight claim. It is also extremely helpful if you need to return your machine later.***



Needed for Setup

The following items are needed, but not included, for the setup/assembly of this machine.

| Description | Qty |
|---|-----------|
| • Hex Wrench 8mm..... | 1 |
| • Additional People | 1 |
| • Safety Glasses | 1 |
| • Cleaner/Degreaser (Page 12) | As Needed |
| • Disposable Shop Rags..... | As Needed |
| • Forklift..... | 1 |
| • Lifting Strap (Rated for at least 750 lbs.).... | 2 |

Inventory

The following is a list of items shipped with your machine. Before beginning setup, lay these items out and inventory them.

If any non-proprietary parts are missing (e.g. a nut or a washer), we will gladly replace them; or for the sake of expediency, replacements can be obtained at your local hardware store.

| Item Inventory (Figure 4) | Qty |
|--|-----|
| A. Machine Body with Pedestal Controls | 1 |
| B. Ball Knob M16-2..... | 1 |
| C. Crank Handle w/Ball Knob M16-2 | 1 |



Figure 4. Model G0792 inventory.

NOTICE

If you cannot find an item on this list, carefully check around/inside the machine and packaging materials. Often, these items get lost in packaging materials while unpacking or they are pre-installed at the factory.



Cleanup

The unpainted surfaces of your machine are coated with a heavy-duty rust preventative that prevents corrosion during shipment and storage. This rust preventative works extremely well, but it will take a little time to clean.

Be patient and do a thorough job cleaning your machine. The time you spend doing this now will give you a better appreciation for the proper care of your machine's unpainted surfaces.

There are many ways to remove this rust preventative, but the following steps work well in a wide variety of situations. Always follow the manufacturer's instructions with any cleaning product you use and make sure you work in a well-ventilated area to minimize exposure to toxic fumes.

Before cleaning, gather the following:

- Disposable rags
- Cleaner/degreaser (WD-40 works well)
- Safety glasses & disposable gloves
- Plastic paint scraper (optional)

Basic steps for removing rust preventative:

1. Put on safety glasses.
2. Coat the rust preventative with a liberal amount of cleaner/degreaser, then let it soak for 5–10 minutes.
3. Wipe off the surfaces. If your cleaner/degreaser is effective, the rust preventative will wipe off easily. If you have a plastic paint scraper, scrape off as much as you can first, then wipe off the rest with the rag.
4. Repeat **Steps 2–3** as necessary until clean, then coat all unpainted surfaces with a quality metal protectant to prevent rust.

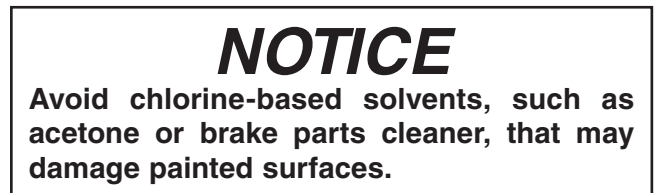
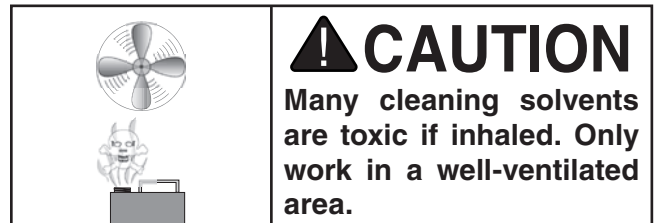
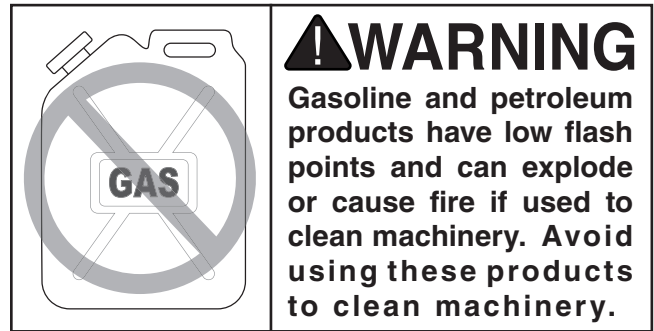

T23692—Orange Power Degreaser

A great product for removing the waxy shipping grease from the **non-painted** parts of the machine during clean up.



Figure 5. T23692 Orange Power Degreaser.



Site Considerations

Weight Load

Refer to the **Machine Data Sheet** for the weight of your machine. Make sure that the surface upon which the machine is placed will bear the weight of the machine, additional equipment that may be installed on the machine, and the heaviest workpiece that will be used. Additionally, consider the weight of the operator and any dynamic loading that may occur when operating the machine.

Space Allocation

Consider the largest size of workpiece that will be processed through this machine and provide enough space around the machine for adequate operator material handling or the installation of auxiliary equipment. With permanent installations, leave enough space around the machine to open or remove doors/covers as required by the maintenance and service described in this manual.

See below for required space allocation.



Physical Environment

The physical environment where the machine is operated is important for safe operation and longevity of machine components. For best results, operate this machine in a dry environment that is free from excessive moisture, hazardous chemicals, airborne abrasives, or extreme conditions. Extreme conditions for this type of machinery are generally those where the ambient temperature range exceeds 41°–104°F; the relative humidity range exceeds 20%–95% (non-condensing); or the environment is subject to vibration, shocks, or bumps.

Electrical Installation

Place this machine near an existing power source. Make sure all power cords are protected from traffic, material handling, moisture, chemicals, or other hazards. Make sure to leave enough space around machine to disconnect power supply or apply a lockout/tagout device, if required.

Lighting

Lighting around the machine must be adequate enough that operations can be performed safely. Shadows, glare, or strobe effects that may distract or impede the operator must be eliminated.

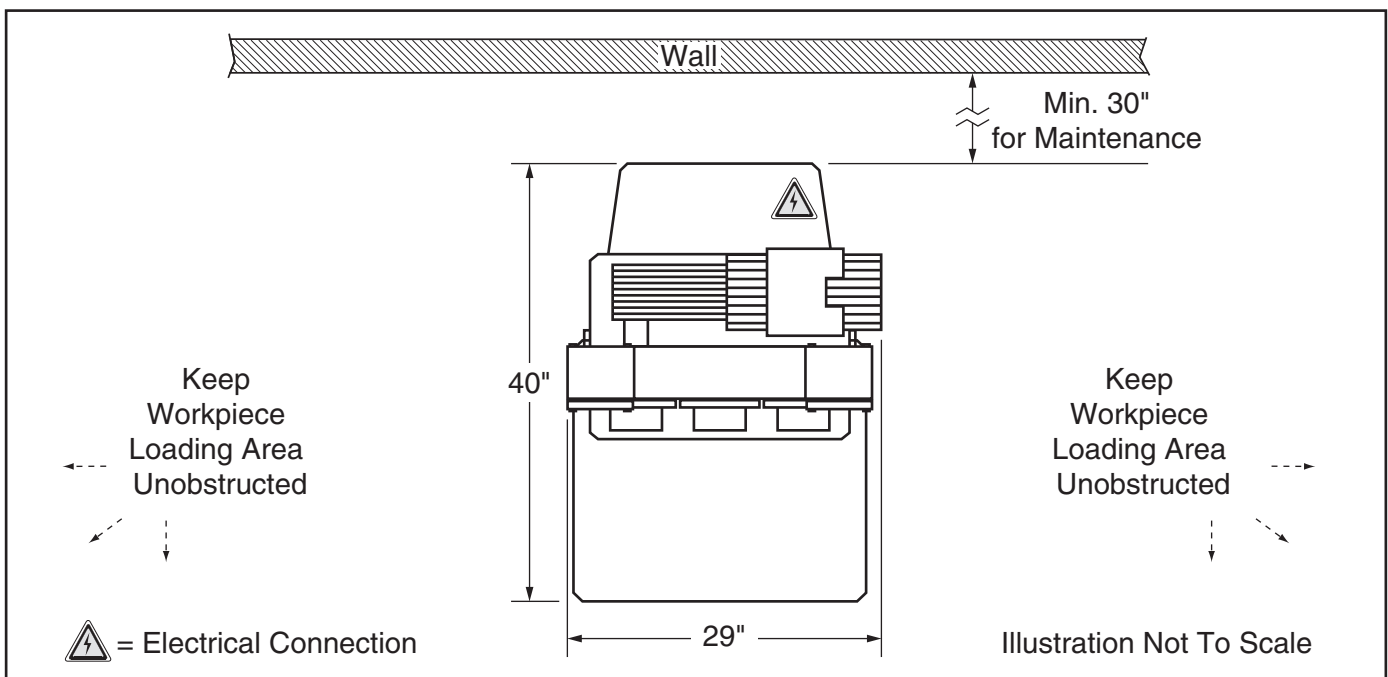

Figure 6. Minimum working clearances.



Assembly

The Model G0792 comes with the headstock in the horizontal position. To safely lift the machine, you must first adjust the headstock to the vertical position and install the upper roller crank handle.

To assemble machine:

1. Use an 8mm hex wrench to remove two cap screws that secure headstock in horizontal position (see **Figure 7**).

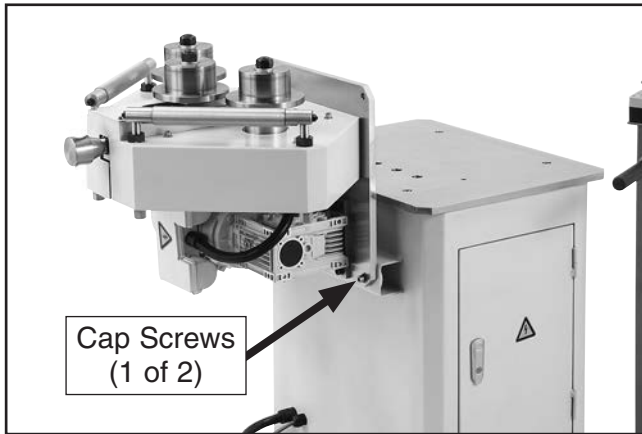

Figure 7. Location of cap screws that secure headstock in horizontal position.

2. With help from an assistant, gently tilt headstock up until it rests on base (see **Figure 8**).
3. Use cap screws removed in **Step 1** to secure headstock to base (see **Figure 8**).
4. Install upper roller crank handle and ball knob, as shown in **Figure 8**.

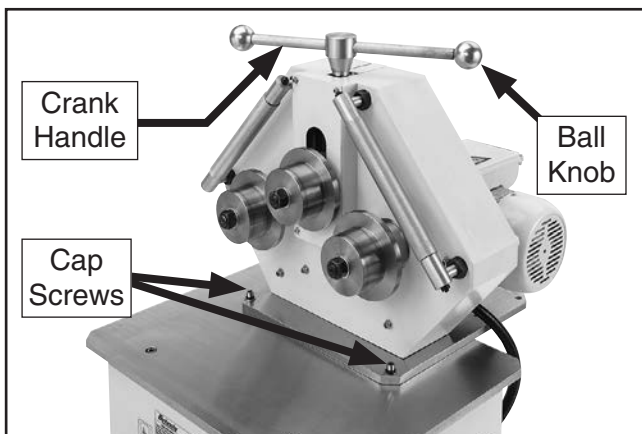
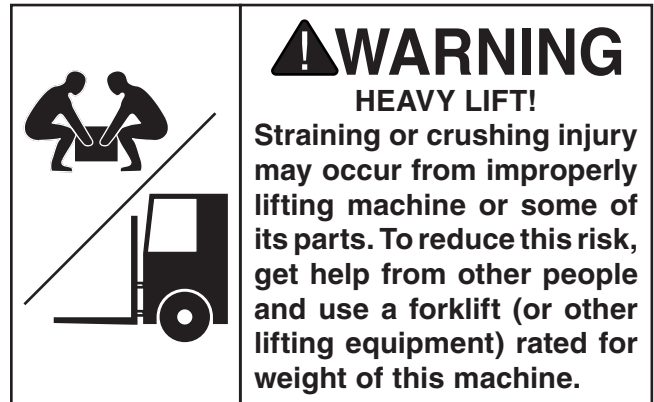

Figure 8. Machine assembled for lifting.

Lifting & Placing



To lift and place the machine, wrap a lifting strap rated for at least 750 lbs. around the crank handle, as shown in **Figure 9**, then use a forklift to lift the machine off of the pallet and onto a suitable location.

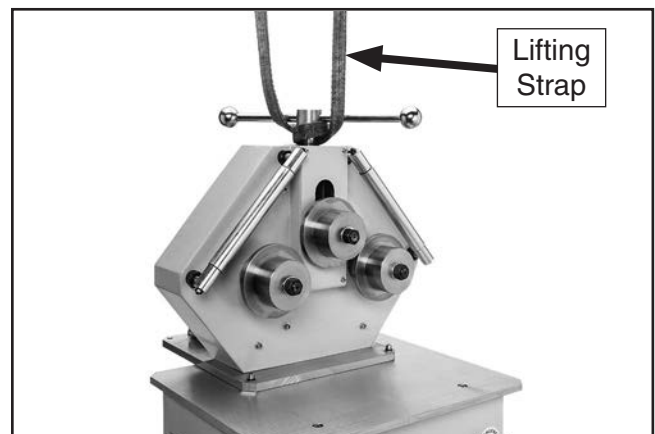

Figure 9. Lifting Model G0792.



Anchoring to Floor

Number of Mounting Holes 4
Diameter of Mounting Hardware..... 1/2"

Anchoring machinery to the floor prevents tipping or shifting and reduces vibration that may occur during operation, resulting in a machine that runs slightly quieter and feels more solid.

If the machine will be installed in a commercial or workplace setting, or if it is permanently connected (hardwired) to the power supply, local codes may require that it be anchored to the floor.

If not required by any local codes, fastening the machine to the floor is an optional step. If you choose not to do this with your machine, we recommend placing it on machine mounts, as these provide an easy method for leveling and they have vibration-absorbing pads.

Anchoring to Concrete Floors

Lag shield anchors with lag screws (see below) are a popular way to anchor machinery to a concrete floor, because the anchors sit flush with the floor surface, making it easy to unbolt and move the machine later, if needed. However, anytime local codes apply, you **MUST** follow the anchoring methodology specified by the code.

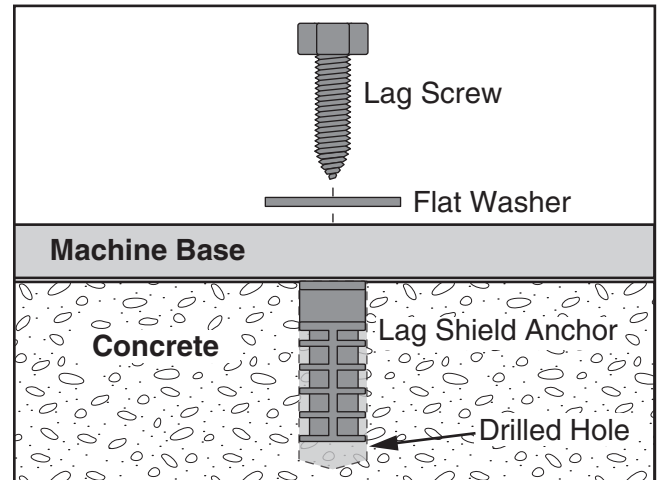

Figure 10. Popular method for anchoring machinery to a concrete floor.



Test Run

!WARNING

DO NOT start machine until all preceding setup instructions have been performed. Operating an improperly set up machine may result in malfunction or unexpected results that can lead to serious injury, death, or machine/property damage.

Once assembly is complete, test run the machine to ensure it is properly connected to power and safety components are functioning correctly.

If you find an unusual problem during the test run, immediately stop the machine, disconnect it from power, and fix the problem **BEFORE** operating the machine again. The **Troubleshooting** table in the **SERVICE** section of this manual can help.

To test run machine:

1. Clear all setup tools away from machine.
2. Push both Emergency Stop/RESET buttons (see **Figure 11**).

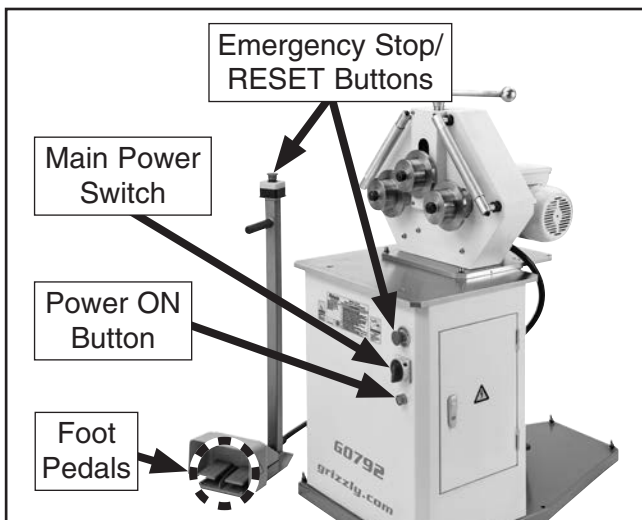

Figure 11. Location of test run controls.

3. Connect machine to power source.

4. Twist both Emergency Stop/RESET buttons clockwise until they pop out—this resets switches so they will allow power to machine.

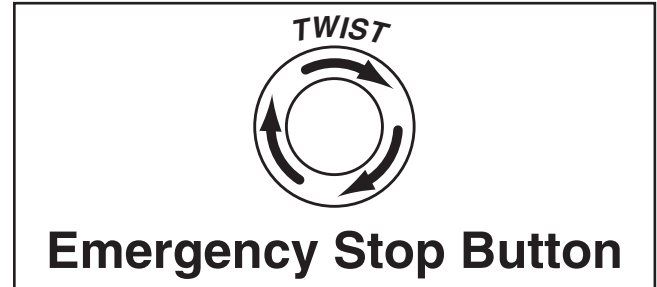

Figure 12. Resetting Emergency Stop/RESET button.

5. Rotate main power switch (**Figure 11**) to ON position.
6. Push POWER ON button (**Figure 11**). Green light on button should illuminate.
7. Step on one foot pedal (**Figure 11**) to turn motor **ON**. Release foot pedal to turn motor **OFF**. A correctly operating machine runs smoothly with little or no vibration or rubbing noises.
8. Repeat **Previous Step** with the other foot pedal to test run motor in opposite direction.
9. Press one Emergency Stop/RESET button, then **WITHOUT** resetting Emergency Stop/RESET button, press POWER ON button and step on one foot pedal. The machine should *not* start.
10. Reset Emergency Stop/RESET button, then repeat **Previous Step** with the other EMERGENCY STOP button.

— If machine *does not* start while either EMERGENCY STOP button is depressed, safety feature is working correctly. Congratulations! Test Run is complete.

— If machine *does* start while either Emergency Stop/RESET button is depressed, immediately disconnect power to machine. Emergency Stop/RESET button safety feature is not working correctly. This safety feature must work properly before proceeding with regular operations. Call Tech Support for help.



SECTION 4: OPERATIONS

Operation Overview

WARNING

Serious injury or death can result from using this machine **BEFORE** understanding its controls and related safety information. **DO NOT** operate, or allow others to operate, machine until the information is understood.

The purpose of this overview is to provide the novice machine operator with a basic understanding of how the machine is used during operation, so the machine controls/components discussed later in this manual are easier to understand.

Due to the generic nature of this overview, it is **not** intended to be an instructional guide. To learn more about specific operations, read this entire manual and seek additional training from experienced machine operators, and do additional research outside of this manual by reading "how-to" books, trade magazines, or websites.

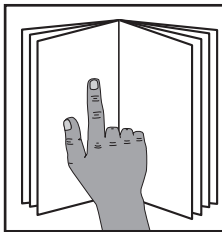

WARNING

To reduce your risk of serious injury, read this entire manual **BEFORE** using machine.



WARNING

Eye injury hazard! Always wear safety glasses when using this machine.

To complete a typical operation, the operator does the following:

1. Determines best working position for operation (horizontal or vertical), and sets up machine accordingly.
2. Examines workpiece to make sure it is suitable for bending.
3. Adjusts upper roller so workpiece may be inserted into rolling jig.
4. Puts on safety glasses.
5. Inserts workpiece so it rests on both lower rollers, then adjusts upper roller, using crank handle, against workpiece with moderate pressure.
6. Turns machine **ON**, and uses foot pedal controls to feed workpiece through, to end of arc. Turns machine **OFF**.
7. Uses crank handle to incrementally increase pressure of upper roller against workpiece.
8. Turns machine **ON**, and feeds workpiece through machine in reverse direction from previous step. Turns machine **OFF**.
9. Repeats **Steps 7–8** until desired arc/radius is achieved.
9. Stops machine and removes workpiece.

NOTICE

If you are not experienced with this type of machine, **WE STRONGLY RECOMMEND** that you seek additional training outside of this manual. Read books/magazines or get formal training before beginning any projects. Regardless of the content in this section, Grizzly Industrial will not be held liable for accidents caused by lack of training.



Rolling Arcs

The Model G0792 Ring Roll Pipe Bender can be used to create arcs, circles, and spirals by feeding the pipe back and forth through the machine with incrementally greater force exerted with each pass by the upper roller until the desired arc or bending amount is achieved.

The machine is capable of bending with the headstock in either a vertical or horizontal position. Typically, the horizontal position is only needed when bending extra long workpieces which could create a space constraint in the vertical position.

Note: During the following steps, the directions "left" and "right" refer to left and right as viewed when facing the front of the machine.

Rolling an Arc in Vertical Position

1. DISCONNECT MACHINE FROM POWER!
2. Use crank handle to raise upper roller, then place workpiece on lower rollers (see **Figure 13**).

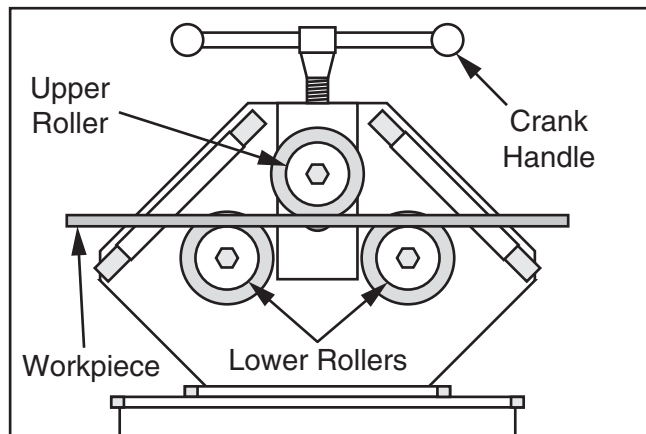

Figure 13. Workpiece placed on lower rollers in preparation for bending.

3. Move upper roller down until it just touches workpiece, as shown in **Figure 14**, then connect machine to power.

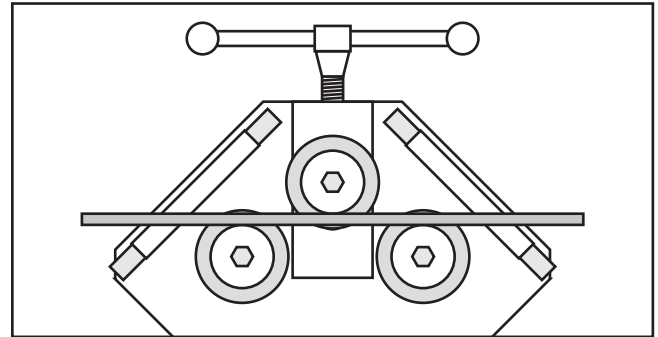

Figure 14. Upper roller lowered onto workpiece.

4. Tighten crank handle an additional $\frac{1}{4}$ – $\frac{1}{2}$ turn.

Note: The amount of additional tightening varies depending on the strength of your workpiece material. Therefore, it is a good idea to first perform a test bend on a piece of scrap material to get a feel for how much force to exert when tightening.

5. Use foot pedal controls (see **Figure 15**) to move workpiece to left or right to create a slight bend in your workpiece (see **Figure 16**).

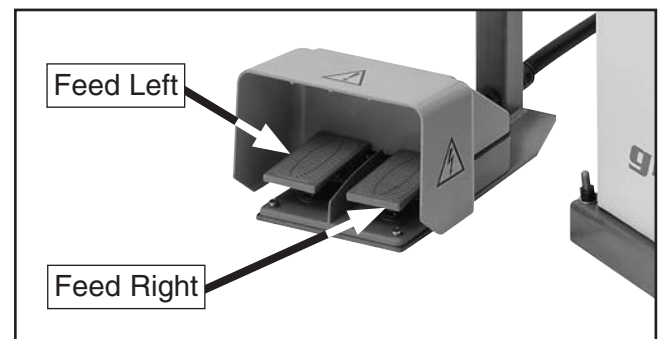

Figure 15. Foot controls for moving workpiece left and right through headstock.

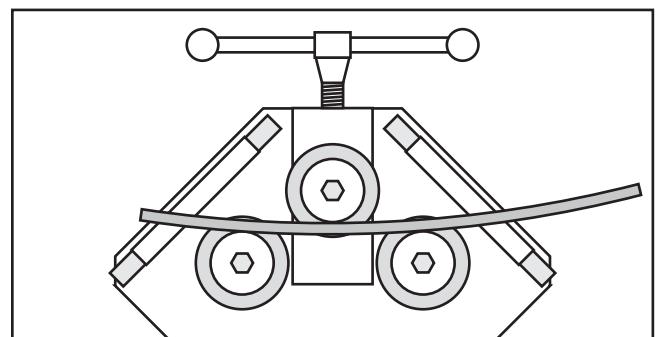

Figure 16. Example of first bending pass.



6. When you reach end of your bend, release foot pedal to stop motor.
7. To increase bend (create a tighter radius), tighten crank handle an additional $\frac{1}{4}$ – $\frac{1}{2}$ turn, as you did previously.
8. Use foot controls to move workpiece in opposite direction to create more bend in workpiece (see **Figure 17**).

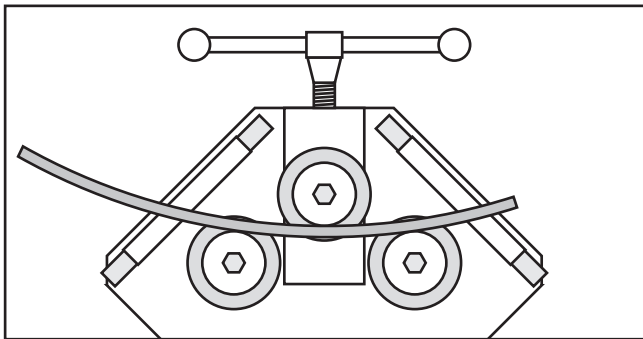

Figure 17. Example of second bending pass.

9. When you reach end of bend, release foot pedal to turn motor **OFF**.
10. Repeat **Steps 4–9** until you achieve desired radius (see **Figure 18**).

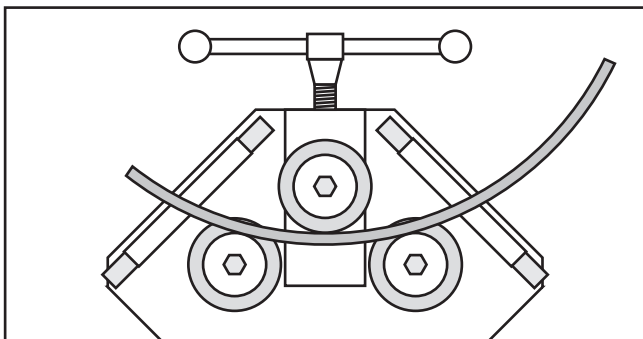

Figure 18. Example bend after multiple bending passes.

Positioning Headstock in Horizontal Position

To roll a long arc, space constraints may make it necessary to change the position of the headstock from the vertical to the horizontal position. The back of the headstock is mounted to a hinge, so it can be easily configured from one position to the other (see **Figure 19**).

Tool Needed

| | Qty |
|---------------------|-----|
| Hex Wrench 8mm..... | 1 |

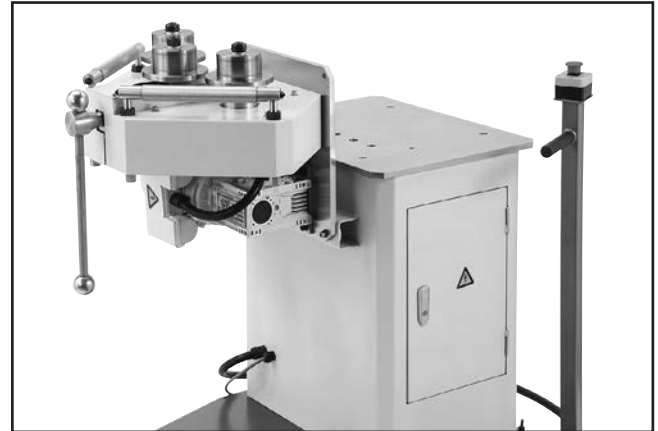

Figure 19. Headstock tilted to horizontal position for bending long arcs.

To position headstock in horizontal position:

1. DISCONNECT MACHINE FROM POWER!
2. Remove two cap screws shown in **Figure 20**.

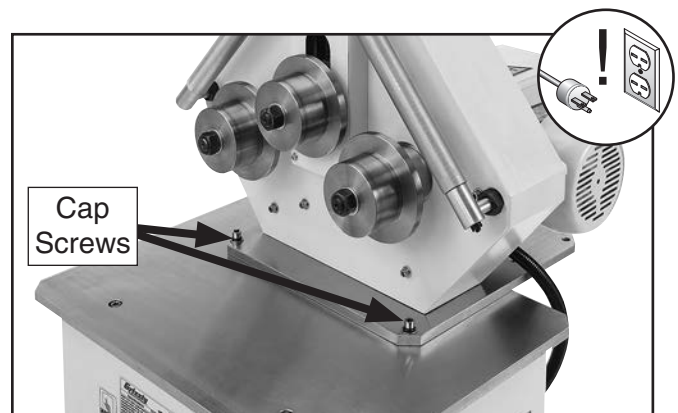

Figure 20. Location of cap screws that secure headstock in vertical position.



3. With help of an assistant, gently tilt headstock backward until it rests on horizontal mount, as shown in **Figure 21**.
4. Use cap screws removed in **Step 2** to secure headstock to horizontal mount (see **Figure 21**).

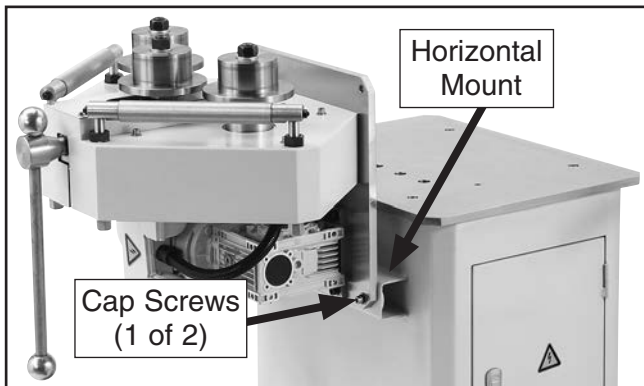

Figure 21. Headstock in horizontal position.

5. Place workpiece in headstock between upper and lower rollers, tighten upper roller just enough to secure workpiece, then connect machine to power.
6. Tighten upper roller an additional $\frac{1}{4}$ – $\frac{1}{2}$ turn, then use foot pedals to move workpiece left and right, each time tightening upper roller more until desired radius is achieved (refer to **Steps 4–10 of Rolling an Arc in Vertical Position** for more details).

Rolling Compound Arcs

Rolling a compound arc requires accessory rollers that do not come with the Model G0792, such as **Round Material Dies** offered by Grizzly (see **Page 22** for more information).

To roll a compound arc you must introduce a slight twist to the arc, so that it bends in both axes. This is accomplished by adjusting one of the guide rollers (see **Figure 22**) so that it exerts lateral force on the workpiece as it passes through the headstock.

Depending on your workpiece material and desired results, the following operation may require some trial and error. It is a good idea to start with a test piece to get a feel for the adjustments needed.

| Tools Needed | Qty |
|----------------------------|------------|
| Open-End Wrench 22mm..... | 1 |
| Open-End Wrench 30mm | 1 |

Rolling Compound Arc

The following instructions are for rolling a compound arc in the vertical position. However, the same procedure applies with the headstock in the horizontal position.

To roll a compound arc:

1. Roll an arc to your desired radius, as illustrated in **Figure 22** (refer to **Rolling Arc in Vertical Position**, beginning on **Page 18**).

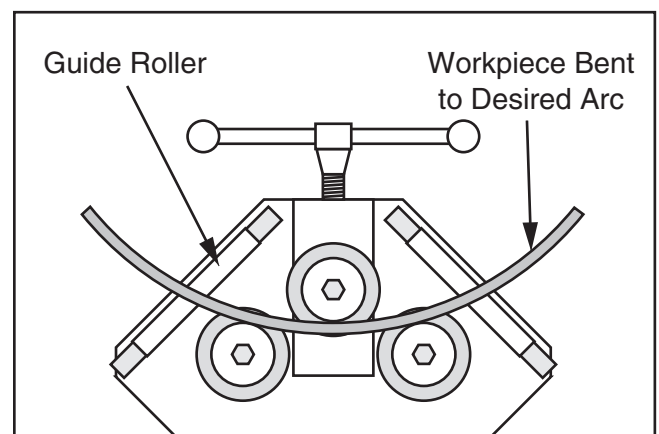

Figure 22. Workpiece positioned on headstock for compound bend.



2. Loosen upper guide retaining nut on outgoing side of headstock (see **Figure 23**).
3. Rotate upper guide adjustment bolt to push guide roller against workpiece (see **Figure 23**).

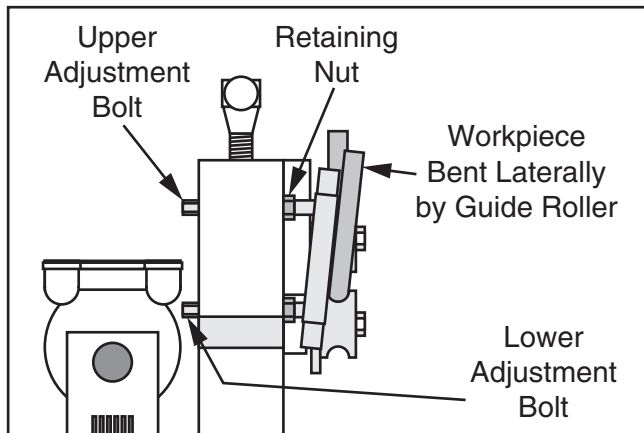

Figure 23. Location of compound bending components (side view).

4. Tighten adjustment bolt an additional $\frac{1}{4}$ –1 turn, depending on strength of workpiece and desired bend, then lock in place by tightening retaining nut from **Step 2**.
5. Use foot controls to advance workpiece through headstock. Position of guide roller will produce a slight twist in workpiece.
6. When you reach end of bend, release foot pedal to stop motor.
 - If you require more twist in your compound arc, use foot controls to reverse workpiece to beginning of bend, then repeat **Steps 2–6** on same side. Repeat until you achieve your desired bend.

Note: Due to differences in workpiece materials and achievable shapes, you will likely need to experiment with a combination of adjustments to get the results you want. This includes rotating the lower adjustment bolt (see **Figure 23**).

Rolling a Continuous Coil

To roll a coil shape (see **Figure 24**) you first must roll as close to a complete circle as possible, then introduce a slight twist to the arc, allowing the bend to continue beyond a complete circle.

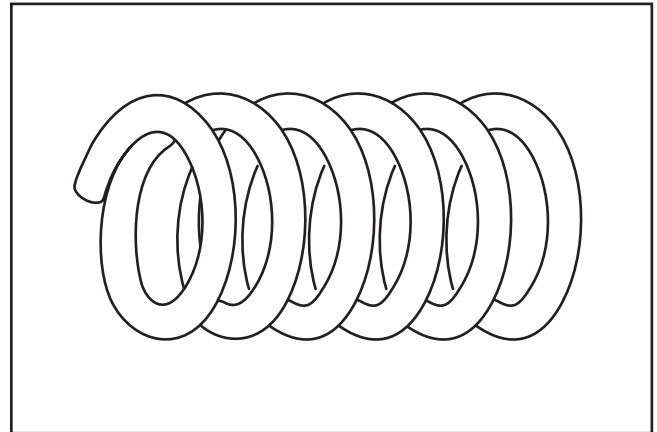

Figure 24. Example of achievable coil shape.

To roll a continuous coil:

1. Follow instructions for rolling an arc (see **Rolling an Arc**, beginning on **Page 18**) until your workpiece is as close to a complete circle as your operation allows.
2. Adjust guide roller on outgoing side of headstock to introduce a slight twist in your workpiece (see **Figure 23** and **Steps 2–4** of **Rolling Compound Arc**).
3. Use foot controls to advance workpiece as far as operation will allow, then release foot pedal to stop motor.
 - If more twist is required, reverse workpiece to beginning of bend and repeat **Steps 2–3** on same side until achieving desired results.



SECTION 5: ACCESSORIES

! WARNING

Installing unapproved accessories may cause machine to malfunction, resulting in serious personal injury or machine damage. To reduce this risk, only install accessories recommended for this machine by Grizzly.

NOTICE

Refer to our website or latest catalog for additional recommended accessories.

G7153—Universal Bender

This heavy-duty universal bender has a bending capacity of 28½ tons to shape steel, iron, wrought iron, brass, copper and aluminum. Make radius bends, rings, spirals and angle bends. Maximum capacity for round bar: 5/8"; square bar: 19/32"; and flat bar: 13/16" x 5/16". U-shape bends: Max ID: 3", Min ID: 3/4". Fully adjustable. Shipping weight is approx. 53 lbs.

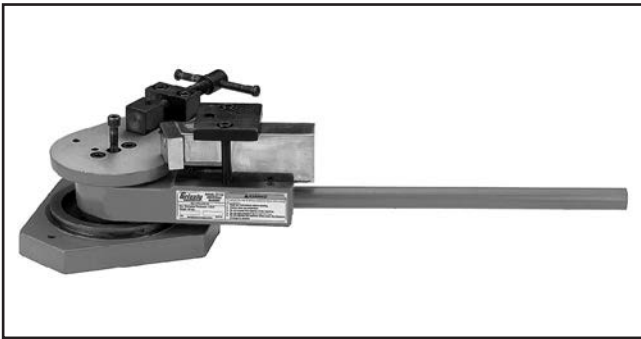

Figure 25. Model G7153 Universal Bender.

Round Material Dies

Expand your bending capability with these round material dies from Grizzly, allowing you to bend round stock for marine hand rails, coils of tubing, decorative iron-work, and much more!

- T27631—1/2" Round**
- T27632—3/4" Round**
- T27633—1" Round**

- SB1365—South Bend Way Oil-ISO 68**
- T23964—Multi-Purpose NLGI#2 Grease**
- G2545—Silicone Lubricant**



Figure 26. Recommended products for machine lubrication.

Basic Eye Protection

- T20501—Face Shield Crown Protector 4"**
- T20502—Face Shield Crown Protector 7"**
- T20503—Face Shield Window**
- T20451—"Kirova" Clear Safety Glasses**
- T20452—"Kirova" Anti-Reflective S. Glasses**
- H7194—Bifocal Safety Glasses 1.5**
- H7195—Bifocal Safety Glasses 2.0**
- H7196—Bifocal Safety Glasses 2.5**

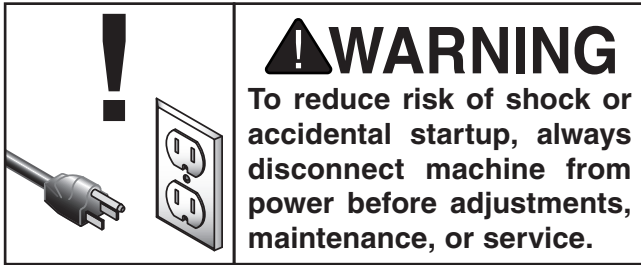

Figure 27. Assortment of basic eye protection.

order online at www.grizzly.com or call 1-800-523-4777



SECTION 6: MAINTENANCE



Schedule

For optimum performance from your machine, follow this maintenance schedule and refer to any specific instructions given in this section.

Daily Check

- Loose mounting bolts.
- Worn or damaged wires.
- Any other unsafe condition.

As Needed

- Check/adjust lubrication of leadscrew.
- Check/adjust lubrication of drive gears.

Cleaning & Protecting

Cleaning the Model G0792 is relatively easy. Wipe down all unpainted and machined surfaces daily to keep them rust free and in top condition. This includes any surface that is vulnerable to rust if left unprotected. Use ISO 68 way oil or any other quality metal lubricant (see **Page 22** for offerings from Grizzly) to prevent corrosion.

Lubrication

For optimum performance, periodically check and, if necessary, lubricate the leadscrew and drive gears.

| Items Needed | Qty |
|----------------------|-----------|
| Hex Wrench 6mm..... | 1 |
| Hex Wrench 4mm..... | 1 |
| Mineral Spirits..... | As Needed |
| Small Brushes | 2 |
| Way Oil ISO 68..... | As Needed |
| Grease NLGI#2 | As Needed |

To access leadscrew and drive gears:

1. DISCONNECT MACHINE FROM POWER!
2. Remove M5-.8 x 12 cap screw and drive shaft cover from back of machine (see **Figure 28**).
3. Remove (6) M8-1.25 x 16 cap screws and drive gear cover (see **Figure 28**).

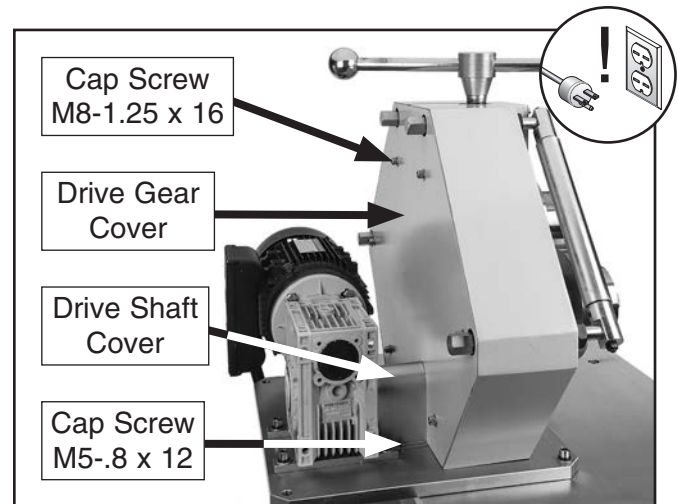

Figure 28. Components to remove before lubricating leadscrew and drive gears.

4. Lubricate leadscrew and drive gears (see **Figure 29** on **Page 24**), as necessary.
5. Re-install drive gear cover and drive shaft cover.



Leadscrew

Oil Type Grizzly T23962 or ISO 68 Equivalent
Oil Amount..... As Needed
Lubrication Frequency..... As Needed

Before lubricating the leadscrew (see **Figure 29**), clean it first with mineral spirits. A stiff brush works well to help clean out the threads. Make sure to raise and lower the upper roller, so you can clean the entire length of the leadscrew.

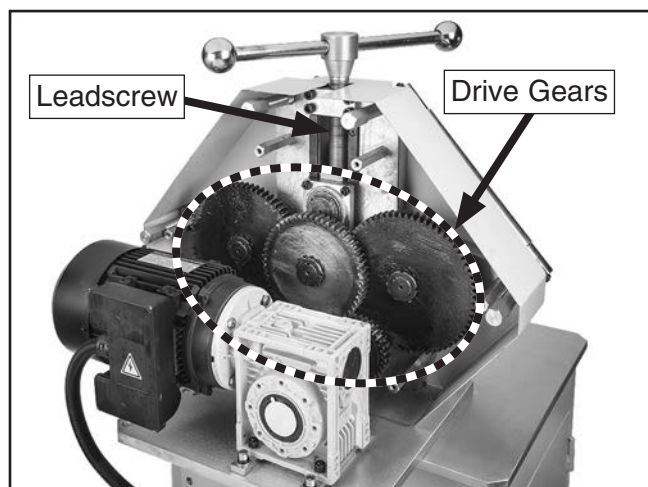

Figure 29. Leadscrew and drive gears exposed for cleaning and lubricating.

Apply a thin coat of oil along the length of the leadscrew. Use a stiff brush to apply oil evenly and down into the threads, then raise and lower the upper roller to thoroughly disperse the oil.

Note: *In some environments, abrasive material can become caught in the leadscrew lubricant and drawn into the leadscrew nut. In this case, lubricate the leadscrew with a quality dry lubricant such as Grizzly G2545 Silicone Lubricant (see **Accessories** on **Page 22**).*

Drive Gears

Grease Type..... T23964 or NLGI#2 Equivalent
Lubrication..... Every 50 Operating Hours

The drive gears, shown in **Figure 29**, should always have a thin coat of heavy grease to minimize corrosion, noise, and wear.

Before lubricating the drive gears, clean them thoroughly with mineral spirits to remove old grease. Use a small brush if necessary to clean between teeth.

Using a clean brush, apply a thin layer of grease on gears. Make sure to get grease between gear teeth, but do not fill teeth valleys.

Apply a small dab of grease where gear teeth mesh together—this grease will be distributed when gears rotate during machine operation.

Note: *If for any reason you need to replace a gear, clean and lubricate all gears at that time.*



SECTION 7: SERVICE

Review the troubleshooting and procedures in this section if a problem develops with your machine. If you need replacement parts or additional help with a procedure, call our Technical Support. **Note:** *Please gather the serial number and manufacture date of your machine before calling.*

Troubleshooting

Motor & Electrical

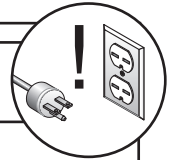

| Symptom | Possible Cause | Possible Solution |
|--|--|---|
| Machine does not start or a breaker trips. | <ol style="list-style-type: none"> Emergency stop button(s) depressed/at fault. Main power switch in OFF position/at fault. Plug/receptacle at fault/wired wrong. Incorrect power supply voltage/circuit size. Power supply circuit breaker tripped or fuse blown. Motor wires connected incorrectly. Contactors not energized/has poor contacts. Wiring open/has high resistance. Power ON button at fault. Foot pedal switch(es) at fault. Start capacitor at fault. Centrifugal switch at fault. Motor at fault. | <ol style="list-style-type: none"> Rotate button head to reset. Replace. Rotate switch to ON position. Replace. Test for good contacts; correct the wiring. Ensure correct power supply voltage/circuit size. Ensure circuit is sized correctly and free of shorts. Reset circuit breaker or replace fuse. Correct motor wiring connections. Test all legs for power/replace. Check/fix broken, disconnected, or corroded wires. Test/replace. Test/replace switch(es). Test/replace. Adjust/replace centrifugal switch if available. Test/repair/replace. |
| Machine stalls or is underpowered. | <ol style="list-style-type: none"> Machine undersized for task. Wrong workpiece material. Motor overheated. Motor wired incorrectly. Contactors not energized/has poor contacts. Plug/receptacle at fault. Gearbox at fault. Run capacitor at fault. Centrifugal switch at fault. Foot pedal switch(es) at fault. Motor bearings at fault. | <ol style="list-style-type: none"> Reduce bending pressure of upper roller. Use correct type/size of metal stock. Clean motor, let cool, and reduce workload. Wire motor correctly. Test all legs for power/replace. Test for good contacts/correct wiring. Replace broken or slipping gears. Test/replace. Adjust/replace centrifugal switch if available. Test/replace switch(es). Test/replace. |
| Machine has vibration or noisy operation. | <ol style="list-style-type: none"> Motor or component loose. Motor fan rubbing on fan cover. Motor mount loose/broken. Machine incorrectly mounted on floor. Roller(s) at fault/incorrectly installed. Centrifugal switch at fault. Motor bearings at fault. | <ol style="list-style-type: none"> Inspect/replace damaged bolts/nuts, and retighten with thread-locking fluid. Fix/replace fan cover; replace loose/damaged fan. Tighten/replace. Tighten mounting bolts; relocate/shim machine. Ensure rollers are correctly installed, replace if necessary. Replace. Test by rotating shaft; rotational grinding/loose shaft requires bearing replacement. |



Machine Operation

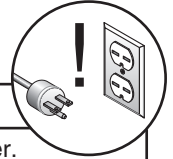

| Symptom | Possible Cause | Possible Solution |
|---|---|---|
| Workpiece deforms, kinks, or is crushed during operation. | <ol style="list-style-type: none"> Excessive bending pressure. Roller profile not compatible with workpiece shape. | <ol style="list-style-type: none"> Reduce bending pressure of upper roller. Use workpiece suitable for bending operation; use correct rollers for shape of workpiece. |
| Workpiece does not move when rollers rotate. | <ol style="list-style-type: none"> Not enough bending pressure. Grease/oil on workpiece/rollers, causing rollers to slip against workpiece. | <ol style="list-style-type: none"> Increase bending pressure of upper roller. Thoroughly clean workpiece/rollers to prevent slipping. |



SECTION 8: WIRING

These pages are current at the time of printing. However, in the spirit of improvement, we may make changes to the electrical systems of future machines. Compare the manufacture date of your machine to the one stated in this manual, and study this section carefully.

If there are differences between your machine and what is shown in this section, call Technical Support at (570) 546-9663 for assistance BEFORE making any changes to the wiring on your machine. An updated wiring diagram may be available. **Note:** *Please gather the serial number and manufacture date of your machine before calling. This information can be found on the main machine label.*

WARNING

Wiring Safety Instructions

SHOCK HAZARD. Working on wiring that is connected to a power source is extremely dangerous. Touching electrified parts will result in personal injury including but not limited to severe burns, electrocution, or death. Disconnect the power from the machine before servicing electrical components!

MODIFICATIONS. Modifying the wiring beyond what is shown in the diagram may lead to unpredictable results, including serious injury or fire. This includes the installation of unapproved after-market parts.

WIRE CONNECTIONS. All connections must be tight to prevent wires from loosening during machine operation. Double-check all wires disconnected or connected during any wiring task to ensure tight connections.

CIRCUIT REQUIREMENTS. You MUST follow the requirements at the beginning of this manual when connecting your machine to a power source.

WIRE/COMPONENT DAMAGE. Damaged wires or components increase the risk of serious personal injury, fire, or machine damage. If you notice that any wires or components are damaged while performing a wiring task, replace those wires or components.

MOTOR WIRING. The motor wiring shown in these diagrams is current at the time of printing but may not match your machine. If you find this to be the case, use the wiring diagram inside the motor junction box.















CAPACITORS/INVERTERS. Some capacitors and power inverters store an electrical charge for up to 10 minutes after being disconnected from the power source. To reduce the risk of being shocked, wait at least this long before working on capacitors.

EXPERIENCING DIFFICULTIES. If you are experiencing difficulties understanding the information included in this section, contact our Technical Support at (570) 546-9663.

NOTICE

The photos and diagrams included in this section are best viewed in color. You can view these pages in color at www.grizzly.com.

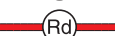
COLOR KEY

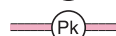
| | | | | | | | |
|-------|---|--------|---|--------------|---|------------|---|
| BLACK |  | BLUE |  | YELLOW |  | LIGHT BLUE |  |
| WHITE |  | BROWN |  | YELLOW GREEN |  | BLUE WHITE |  |
| GREEN |  | GRAY |  | PURPLE |  | TURQUOISE |  |
| RED |  | ORANGE |  | PINK |  | | |



Electrical Components

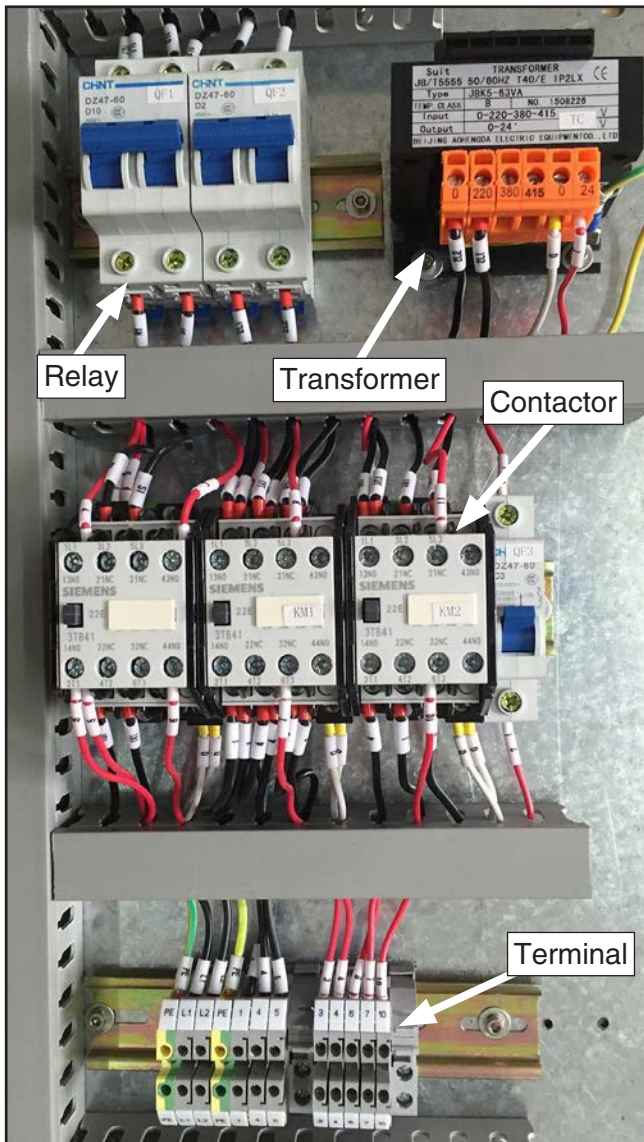

Figure 30. Electrical cabinet components.



Figure 31. Foot pedal wiring.

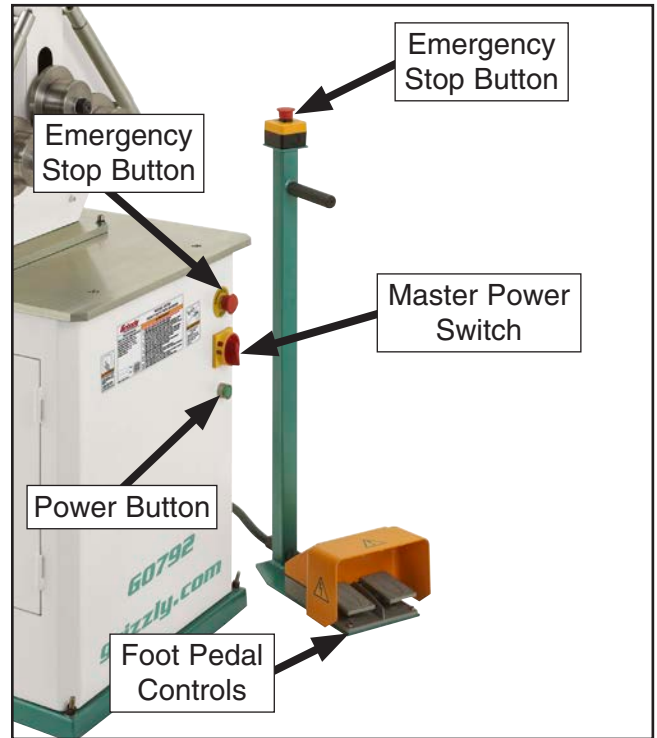

Figure 32. Foot pedal assembly, emergency stop button, and forward-facing controls.



Figure 33. Motor junction box and starting switch.



Electrical Panel Wiring Diagram

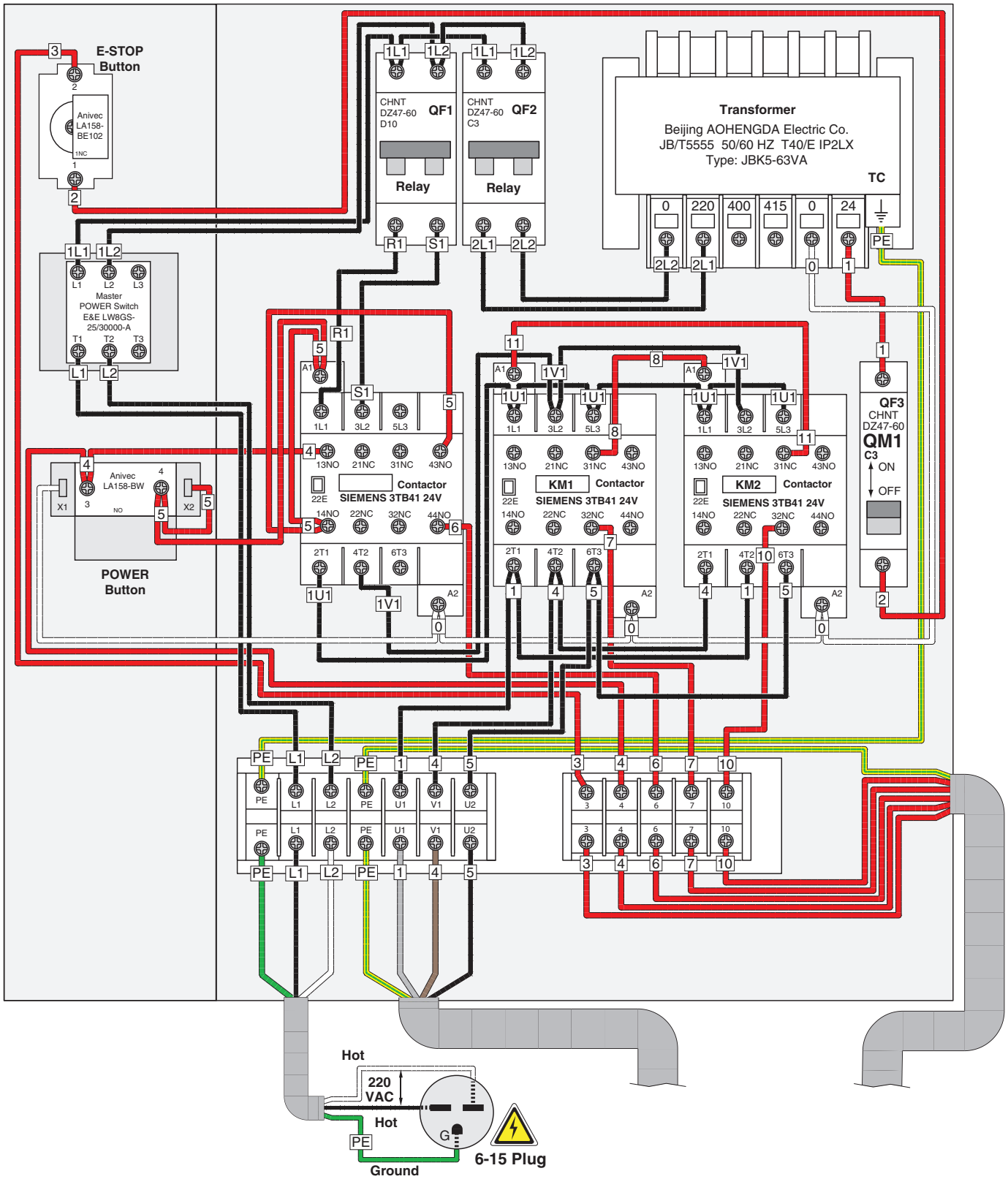

Motor Diagram

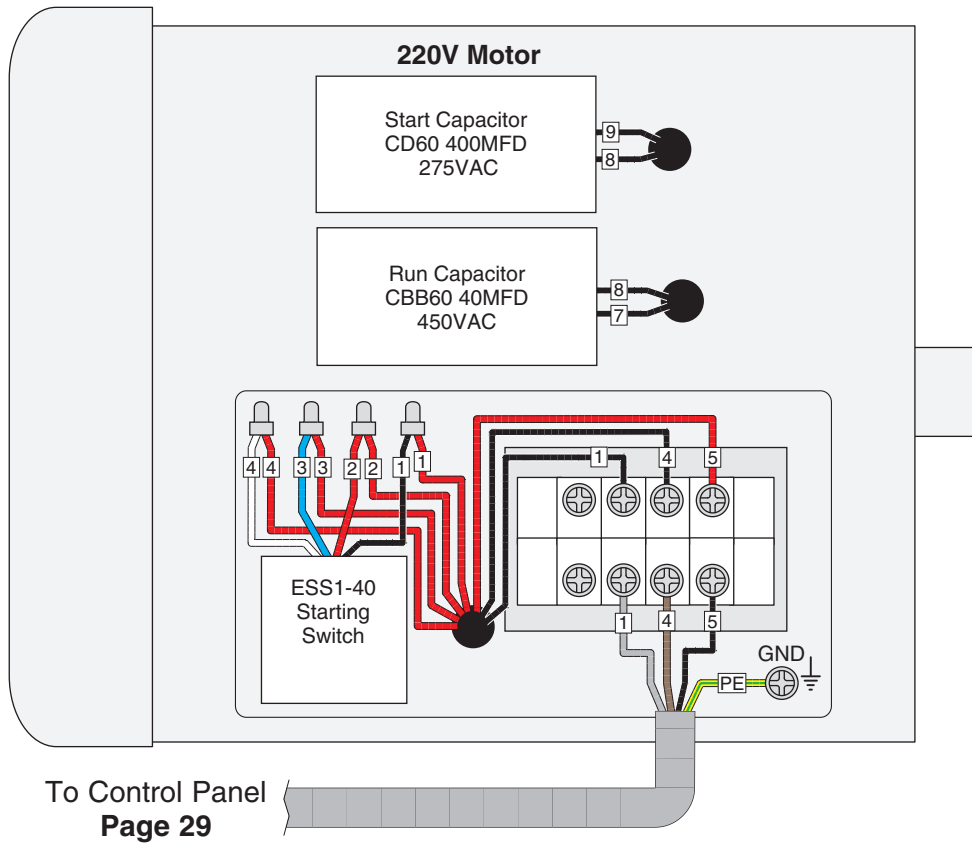

Foot Pedal & E-Stop Diagram

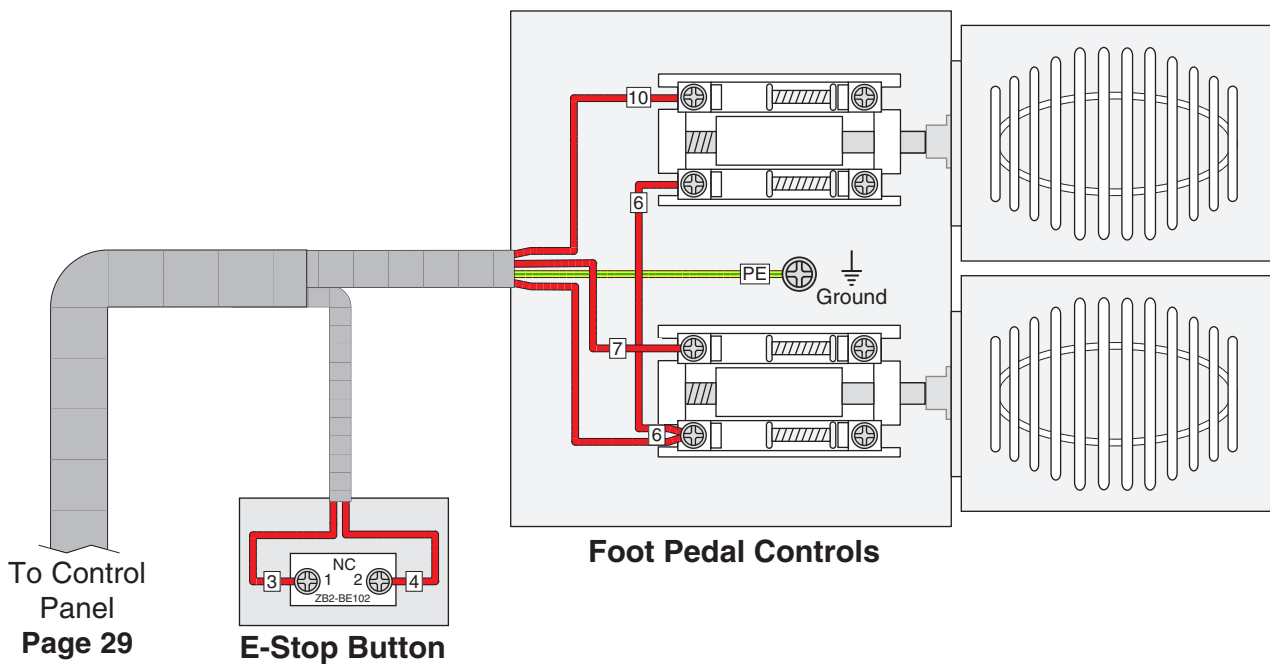

SECTION 9: PARTS

We do our best to stock replacement parts when possible, but we cannot guarantee that all parts shown are available for purchase. Call (800) 523-4777 or visit www.grizzly.com/parts to check for availability.

Main

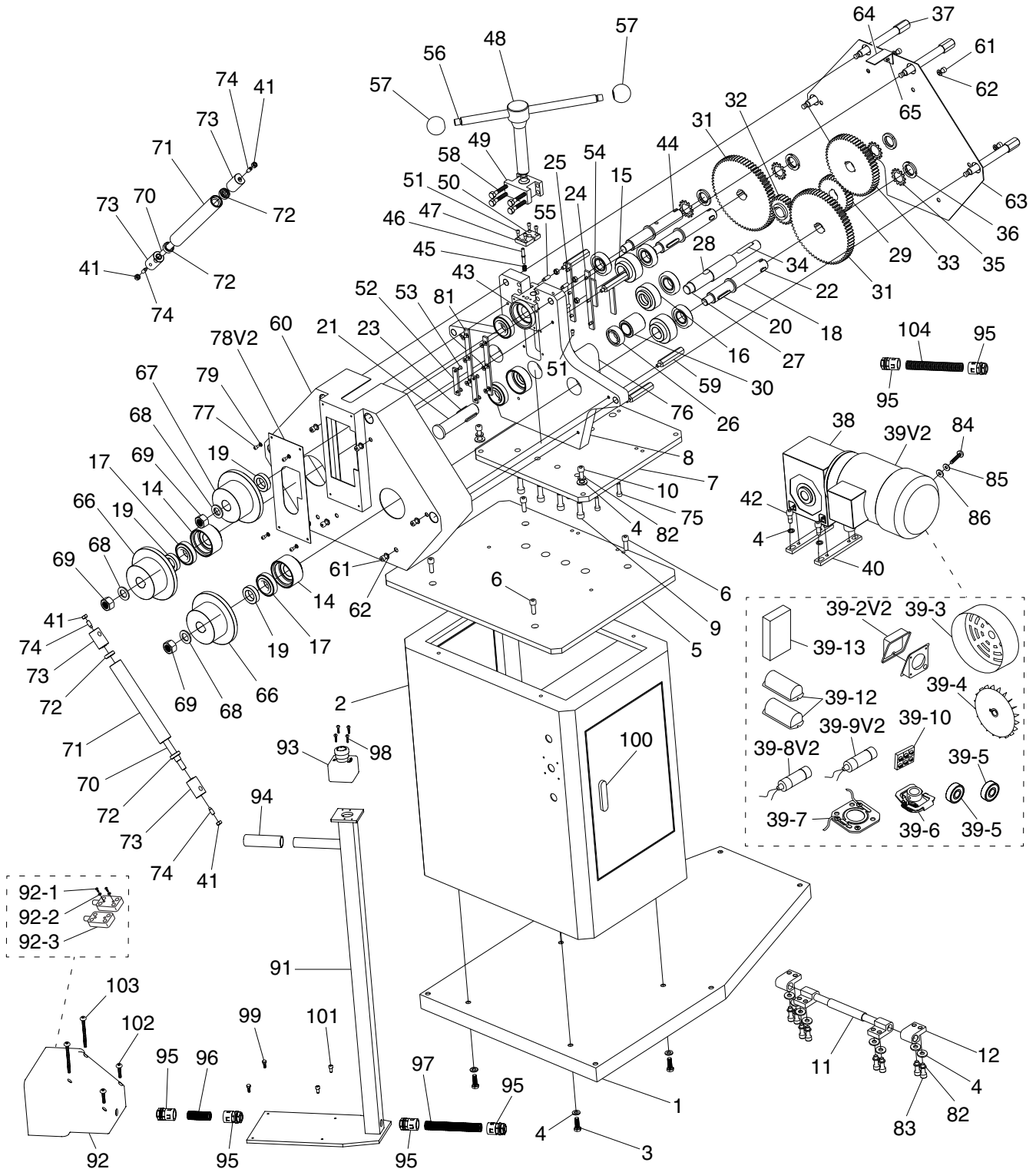

Main Parts List

| REF | PART # | DESCRIPTION | REF | PART # | DESCRIPTION |
|--------|--------------|---|------|------------|--|
| 1 | P0792001 | BASE PLATE | 47 | P0792047 | ELEVATION SPACER BLOCK (LARGE) |
| 2 | P0792002 | STAND W/DOOR | 48 | P0792048 | ELEVATION LEVER SHAFT |
| 3 | P0792003 | HEX BOLT M10-1.5 X 30 | 49 | P0792049 | ELEVATION SUPPORT BLOCK |
| 4 | P0792004 | FLAT WASHER 10MM | 50 | P0792050 | ELEVATION SPACER BLOCK (SMALL) |
| 5 | P0792005 | MAIN PLATE | 51 | P0792051 | CAP SCREW M5-.8 X 12 |
| 6 | P0792006 | CAP SCREW M10-1.5 X 30 | 52 | P0792052 | VERTICAL SLIDE BLOCK, SHORT (FRONT) |
| 7 | P0792007 | PIVOT PLATE | 53 | P0792053 | FLAT HD CAP SCR M5-.8 X 10 |
| 8 | P0792008 | GEARING PLATE | 54 | P0792054 | VERTICAL SLIDE BLOCK, SHORT (REAR) |
| 9 | P0792009 | CAP SCREW M12-1.75 X 35 | 55 | P0792055 | SET SCREW M8-1.25 X 25 DOG-PT |
| 10 | P0792010 | CAP SCREW M10-1.5 X 35 | 56 | P0792056 | HANDLE SHAFT M16-2 X 16, 395L |
| 11 | P0792011 | PIVOT SHAFT | 57 | P0792057 | ROUND KNOB M16-2 SS |
| 12 | P0792012 | HINGE | 58 | P0792058 | HEX BOLT M10-1.5 X 60 |
| 14 | P0792014 | OUTER BEARING SLEEVE | 59 | P0792059 | STAND-OFF HEX MF M8-1.25 X 14, M8-1.25 |
| 15 | P0792015 | INNER BEARING SLEEVE (LEFT) | 60 | P0792060 | FRONT COVER |
| 16 | P0792016 | INNER BEARING SLEEVE (RIGHT) | 61 | P0792061 | CAP SCREW M8-1.25 X 16 |
| 17 | P0792017 | TAPERED ROLLER BEARING 30206 | 62 | P0792062 | FLAT WASHER 8MM |
| 18 | P0792018 | GEAR SHAFT | 63 | P0792063 | BACK COVER |
| 19 | P0792019 | SPACER | 64 | P0792064 | ANGLE BRACKET |
| 20 | P0792020 | KEY 8 X 8 X 45 | 65 | P0792065 | CAP SCREW M6-1 X 10 |
| 21 | P0792021 | SHAFT | 66 | P0792066 | ROLLER FLAT 3-13/16" (LOWER) |
| 22 | P0792022 | KEY 8 X 8 X 18 | 67 | P0792067 | ROLLER FLAT 3-13/16" (UPPER) |
| 23 | P0792023 | KEY 8 X 8 X 40 | 68 | P0792068 | FLAT WASHER 20MM |
| 24 | P0792024 | VERTICAL SLIDE BLOCK, LONG (REAR) | 69 | P0792069 | HEX NUT M20-1.5 |
| 25 | P0792025 | FLAT HD CAP SCR M6-1 X 12 | 70 | P0792070 | GUIDE ROLLER SHAFT |
| 26 | P0792026 | BALL BEARING 6205-2RS | 71 | P0792071 | GUIDE ROLLER SLEEVE |
| 27 | P0792027 | GEAR SHAFT | 72 | P0792072 | BALL BEARING 6001-2RS |
| 28 | P0792028 | KEY 10 X 10 X 19 | 73 | P0792073 | GUIDE ROLLER BRACKET |
| 29 | P0792029 | GEAR 33T | 74 | P0792074 | SET SCREW M8-1.25 X 20 DOG-PT |
| 30 | P0792030 | BUSHING | 75 | P0792075 | CAP SCREW M8-1.25 X 30 |
| 31 | P0792031 | GEAR 68T | 76 | P0792076 | DRIVESHAFT COVER |
| 32 | P0792032 | GEAR 24T | 77 | P0792077 | CAP SCREW M5-.8 X 10 |
| 33 | P0792033 | GEAR 55T | 78V2 | P0792078V2 | UPPER ROLLER PLATE W/SCALE V2.12.15 |
| 34 | P0792034 | KEY 8 X 8 X 56 | 79 | P0792079 | FLAT WASHER 5MM |
| 35 | P0792035 | EXT TOOTH LOCK WASHER 30MM | 81 | P0792081 | VERTICAL SLIDE BLOCK, LONG (FRONT) |
| 36 | P0792036 | SPANNER NUT M30-1.5 | 82 | P0792082 | LOCK WASHER 10MM |
| 37 | P0792037 | ROLLER GUIDE ADJUSTMENT SHAFT | 83 | P0792083 | CAP SCREW M10-1.5 X 30 |
| 38 | P0792038 | GEARBOX | 84 | P0792084 | PHLP HD SCR M4-.7 X 8 |
| 39V2 | P0792039V2 | MOTOR 2HP 220V 1-PH V2.12.15 | 85 | P0792085 | WAVY WASHER 4MM |
| 39-2V2 | P0792039-2V2 | MOTOR JUNCTION BOX V2.12.15 | 86 | P0792086 | FLAT WASHER 4MM |
| 39-3 | P0792039-3 | MOTOR FAN COVER | 91 | P0792091 | PEDAL SWITCH STAND |
| 39-4 | P0792039-4 | MOTOR FAN | 92 | P0792092 | PEDAL SWITCH ASSEMBLY |
| 39-5 | P0792039-5 | BALL BEARING 6205-2RS | 92-1 | P0792092-1 | PHLP HD SCR M3-.5 X 12 |
| 39-6 | P0792039-6 | CENTRIFUGAL SWITCH | 92-2 | P0792092-2 | FLAT WASHER 3MM |
| 39-7 | P0792039-7 | CONTACT PLATE | 92-3 | P0792092-3 | FOOT PEDAL SWITCH |
| 39-8V2 | P0792039-8V2 | S CAPACITOR 400M 275V 2 X 4 V2.12.15 | 93 | P0792093 | E-STOP BUTTON ZB2-BE102 |
| 39-9V2 | P0792039-9V2 | R CAPACITOR 40M 450V 2 X 3-3/4 V2.12.15 | 94 | P0792094 | HANDLE GRIP 25 X 128MM |
| 39-10 | P0792039-10 | TERMINAL BLOCK 3P | 95 | P0792095 | STRAIN RELIEF M20-1.5 TYPE-5 |
| 39-11 | P0792039-11 | TAP SCREW M3 X 12 | 96 | P0792096 | FLEXIBLE CONDUIT 7/8" X 3-1/2" (PLASTIC) |
| 39-12 | P0792039-12 | CAPACITOR COVER | 97 | P0792097 | FLEXIBLE CONDUIT 7/8" X 63" (PLASTIC) |
| 39-13 | P0792039-13 | ELECTRONIC START SWITCH ESS1-40 | 98 | P0792098 | PHLP HD SCR M4-.7 X 28 |
| 40 | P0792040 | MOTOR MOUNT BLOCK | 99 | P0792099 | HEX BOLT M6-1 X 12 |
| 41 | P0792041 | HEX NUT M8-1.25 | 100 | P0792100 | DOOR LATCH W/KEY |
| 42 | P0792042 | CAP SCREW M10-1.5 X 25 | 101 | P0792101 | CAP SCREW M6-1 X 16 |
| 43 | P0792043 | ELEVATION SLIDE BLOCK | 102 | P0792102 | PHLP HD SCR M5-.8 X 26 |
| 44 | P0792044 | GEAR SHAFT | 103 | P0792103 | PHLP HD SCR M5-.8 X 95 |
| 45 | P0792045 | COMPRESSION SPRING 10.5 X 15 | 104 | P0792104 | FLEXIBLE CONDUIT 7/8" X 24" (PLASTIC) |
| 46 | P0792046 | SPRING SHAFT | | | |



Electrical Panel

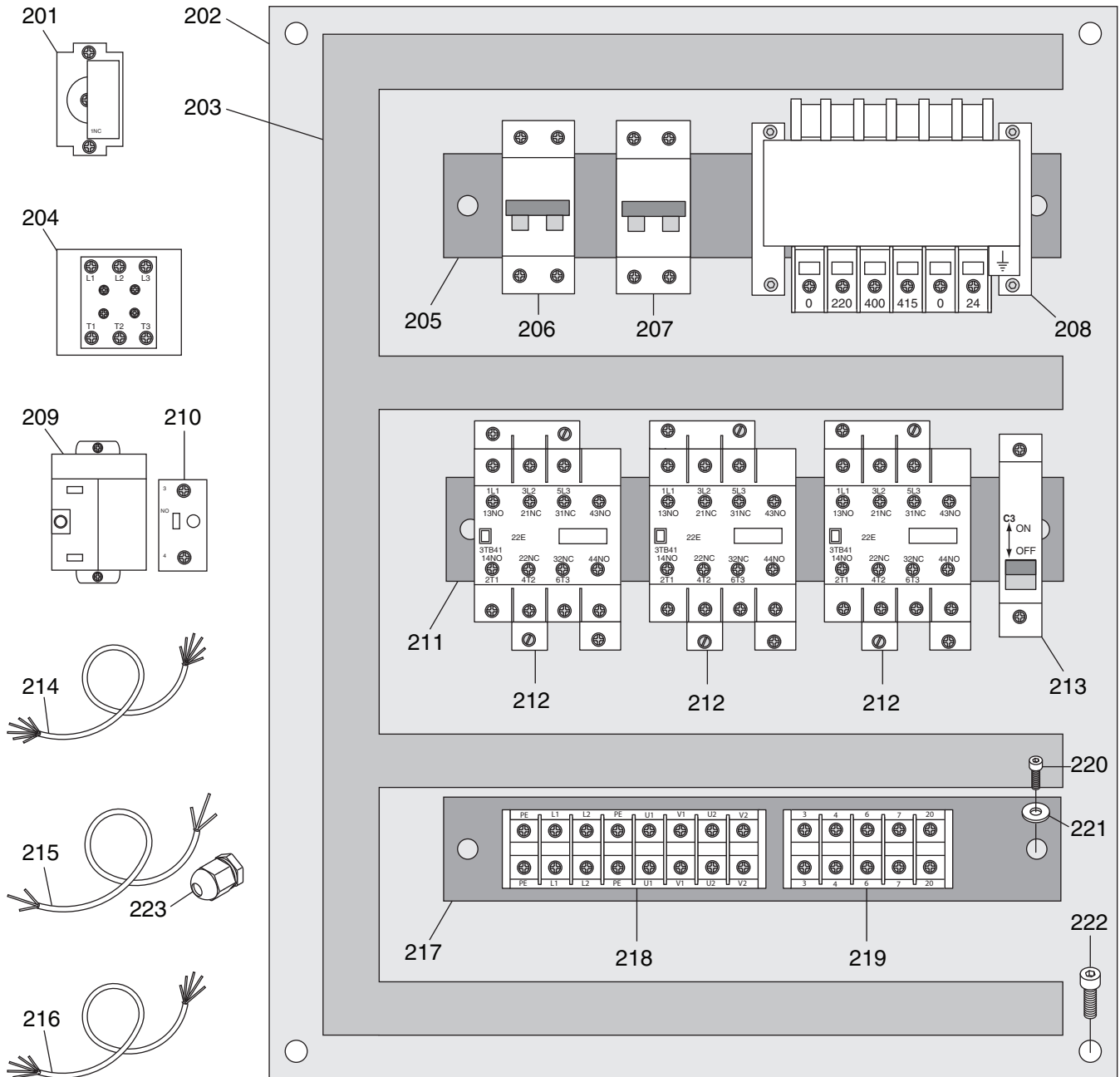

| REF PART # | DESCRIPTION |
|------------|--|
| 201 | P0792201 E-STOP BUTTON ANIUEC LA158-BE102 |
| 202 | P0792202 ELECTRICAL PANEL MOUNTING PLATE |
| 203 | P0792203 WIRE RACEWAY |
| 204 | P0792204 POWER SWITCH E&E LW8GS-25/30000 |
| 205 | P0792205 DIN RAIL (UPPER) |
| 206 | P0792206 CIRCUIT BREAKER 10A CHNT DZ47-60 D10 2P |
| 207 | P0792207 CIRCUIT BREAKER 3A CHNT DZ47-60 C3 2P |
| 208 | P0792208 TRANSFORMER BEIJ AOHENGDA JB/T555 |
| 209 | P0792209 POWER LAMP ANIUEC LA158-BW 24V |
| 210 | P0792210 POWER BUTTON ANIUEC LA158-BE101 |
| 211 | P0792211 DIN RAIL (MIDDLE) |
| 212 | P0792212 CONTACTOR SIEMENS 3TB41 22-0X |

| REF PART # | DESCRIPTION |
|------------|--|
| 213 | P0792213 CIRCUIT BREAKER 3A CHNT DZ47-60 C3 1P |
| 214 | P0792214 FOOT SWITCH CORD 12G 6W 60" |
| 215 | P0792215 POWER CORD 12G 3W 72" |
| 216 | P0792216 MOTOR CORD 12G 5W 48" |
| 217 | P0792217 DIN RAIL (LOWER) |
| 218 | P0792218 TERMINAL BAR 8P |
| 219 | P0792219 TERMINAL BAR 5P |
| 220 | P0792220 CAP SCREW M4-.7 X 8 |
| 221 | P0792221 FLAT WASHER 4MM |
| 222 | P0792222 CAP SCREW M6-1 X 12 |
| 223 | P0792223 STRAIN RELIEF M20-2 TYPE-3 |



Labels & Cosmetics

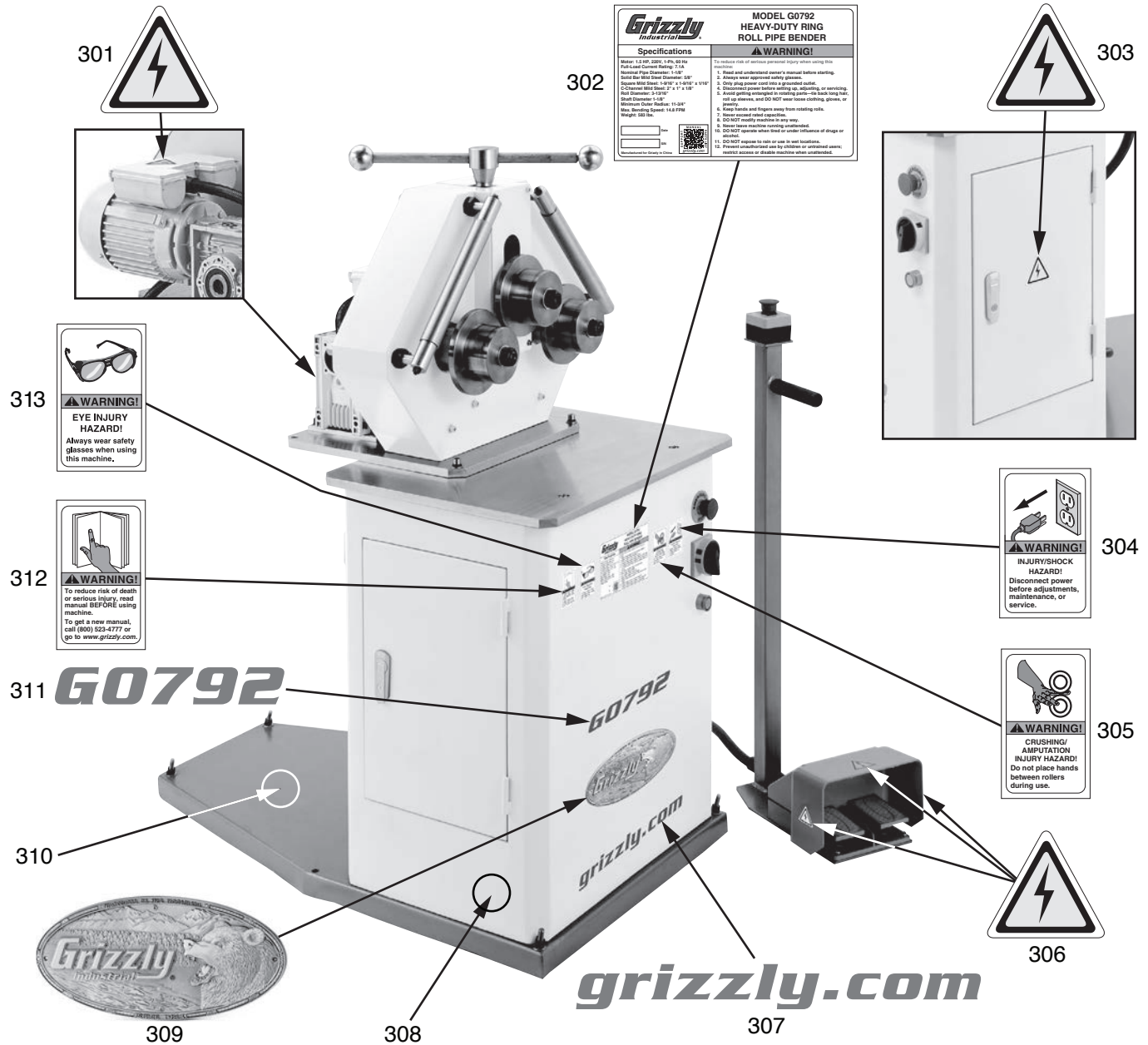

| REF | PART # | DESCRIPTION |
|-----|----------|----------------------------------|
| 301 | P0792301 | ELECTRICITY LABEL |
| 302 | P0792302 | MACHINE ID LABEL |
| 303 | P0792303 | ELECTRICITY LABEL |
| 304 | P0792304 | DISCONNECT POWER LABEL |
| 305 | P0792305 | CRUSHING/AMPUTATION HAZARD LABEL |
| 306 | P0792306 | ELECTRICITY LABEL |
| 307 | P0792307 | GRIZZLY.COM LABEL |

| REF | PART # | DESCRIPTION |
|-----|----------|------------------------------|
| 308 | P0792308 | GRIZZLY BEIGE TOUCH-UP PAINT |
| 309 | P0792309 | GRIZZLY NAMEPLATE |
| 310 | P0792310 | GRIZZLY GREEN TOUCH-UP PAINT |
| 311 | P0792311 | MODEL NUMBER LABEL |
| 312 | P0792312 | READ MANUAL LABEL |
| 313 | P0792313 | EYE INJURY HAZARD LABEL |

⚠️ WARNING

Safety labels help reduce the risk of serious injury caused by machine hazards. If any label comes off or becomes unreadable, the owner of this machine **MUST** replace it in the original location before resuming operations. For replacements, contact (800) 523-4777 or www.grizzly.com.





WARRANTY CARD

Name _____
 Street _____
 City _____ State _____ Zip _____
 Phone # _____ Email _____
 Model # _____ Order # _____ Serial # _____

The following information is given on a voluntary basis. It will be used for marketing purposes to help us develop better products and services. **Of course, all information is strictly confidential.**

- How did you learn about us?

| | | |
|--|----------------------------------|----------------------------------|
| <input type="checkbox"/> Advertisement | <input type="checkbox"/> Friend | <input type="checkbox"/> Catalog |
| <input type="checkbox"/> Card Deck | <input type="checkbox"/> Website | <input type="checkbox"/> Other: |
- Which of the following magazines do you subscribe to?

| | | |
|---|--|---|
| <input type="checkbox"/> Cabinetmaker & FDM | <input type="checkbox"/> Popular Science | <input type="checkbox"/> Wooden Boat |
| <input type="checkbox"/> Family Handyman | <input type="checkbox"/> Popular Woodworking | <input type="checkbox"/> Woodshop News |
| <input type="checkbox"/> Hand Loader | <input type="checkbox"/> Precision Shooter | <input type="checkbox"/> Woodsmith |
| <input type="checkbox"/> Handy | <input type="checkbox"/> Projects in Metal | <input type="checkbox"/> Woodwork |
| <input type="checkbox"/> Home Shop Machinist | <input type="checkbox"/> RC Modeler | <input type="checkbox"/> Woodworker West |
| <input type="checkbox"/> Journal of Light Cont. | <input type="checkbox"/> Rifle | <input type="checkbox"/> Woodworker's Journal |
| <input type="checkbox"/> Live Steam | <input type="checkbox"/> Shop Notes | <input type="checkbox"/> Other: |
| <input type="checkbox"/> Model Airplane News | <input type="checkbox"/> Shotgun News | |
| <input type="checkbox"/> Old House Journal | <input type="checkbox"/> Today's Homeowner | |
| <input type="checkbox"/> Popular Mechanics | <input type="checkbox"/> Wood | |
- What is your annual household income?

| | | |
|--|--|--|
| <input type="checkbox"/> \$20,000-\$29,000 | <input type="checkbox"/> \$30,000-\$39,000 | <input type="checkbox"/> \$40,000-\$49,000 |
| <input type="checkbox"/> \$50,000-\$59,000 | <input type="checkbox"/> \$60,000-\$69,000 | <input type="checkbox"/> \$70,000+ |
- What is your age group?

| | | |
|--------------------------------|--------------------------------|--------------------------------|
| <input type="checkbox"/> 20-29 | <input type="checkbox"/> 30-39 | <input type="checkbox"/> 40-49 |
| <input type="checkbox"/> 50-59 | <input type="checkbox"/> 60-69 | <input type="checkbox"/> 70+ |
- How long have you been a woodworker/metalworker?

| | | | |
|------------------------------------|------------------------------------|-------------------------------------|------------------------------------|
| <input type="checkbox"/> 0-2 Years | <input type="checkbox"/> 2-8 Years | <input type="checkbox"/> 8-20 Years | <input type="checkbox"/> 20+ Years |
|------------------------------------|------------------------------------|-------------------------------------|------------------------------------|
- How many of your machines or tools are Grizzly?

| | | | |
|------------------------------|------------------------------|------------------------------|------------------------------|
| <input type="checkbox"/> 0-2 | <input type="checkbox"/> 3-5 | <input type="checkbox"/> 6-9 | <input type="checkbox"/> 10+ |
|------------------------------|------------------------------|------------------------------|------------------------------|
- Do you think your machine represents a good value? Yes No
- Would you recommend Grizzly Industrial to a friend? Yes No
- Would you allow us to use your name as a reference for Grizzly customers in your area?
Note: We never use names more than 3 times. Yes No

10. Comments: _____

CUT ALONG DOTTED LINE

FOLD ALONG DOTTED LINE



Place
Stamp
Here



GRIZZLY INDUSTRIAL, INC.
P.O. BOX 2069
BELLINGHAM, WA 98227-2069



FOLD ALONG DOTTED LINE

Send a Grizzly Catalog to a friend:

Name _____
Street _____
City _____ State _____ Zip _____

TAPE ALONG EDGES--PLEASE DO NOT STAPLE

WARRANTY & RETURNS

Grizzly Industrial, Inc. warrants every product it sells for a period of **1 year** to the original purchaser from the date of purchase. This warranty does not apply to defects due directly or indirectly to misuse, abuse, negligence, accidents, repairs or alterations or lack of maintenance. This is Grizzly's sole written warranty and any and all warranties that may be implied by law, including any merchantability or fitness, for any particular purpose, are hereby limited to the duration of this written warranty. We do not warrant or represent that the merchandise complies with the provisions of any law or acts unless the manufacturer so warrants. In no event shall Grizzly's liability under this warranty exceed the purchase price paid for the product and any legal actions brought against Grizzly shall be tried in the State of Washington, County of Whatcom.

We shall in no event be liable for death, injuries to persons or property or for incidental, contingent, special, or consequential damages arising from the use of our products.

To take advantage of this warranty, contact us by mail or phone and give us all the details. We will then issue you a "Return Number," which must be clearly posted on the outside as well as the inside of the carton. We will not accept any item back without this number. Proof of purchase must accompany the merchandise.

The manufacturers reserve the right to change specifications at any time because they constantly strive to achieve better quality equipment. We make every effort to ensure that our products meet high quality and durability standards and we hope you never need to use this warranty.

Please feel free to write or call us if you have any questions about the machine or the manual.

Thank you again for your business and continued support. We hope to serve you again soon.

grizzly.com®
TOOL WEBSITE

Buy Direct and Save with Grizzly® – Trusted, Proven and a Great Value!
~Since 1983~

*Visit Our Website Today For
Current Specials!*

**ORDER
24 HOURS A DAY!
1-800-523-4777**

