

Grizzly *Industrial, Inc.*®

MODEL G0718 HINGE BORING MACHINE OWNER'S MANUAL *(For models manufactured since 12/10)*



COPYRIGHT © MAY, 2011 BY GRIZZLY INDUSTRIAL, INC. REVISED MAY, 2018 (BL)
**WARNING: NO PORTION OF THIS MANUAL MAY BE REPRODUCED IN ANY SHAPE
OR FORM WITHOUT THE WRITTEN APPROVAL OF GRIZZLY INDUSTRIAL, INC.**

#CRBLJBTS13651 PRINTED IN TAIWAN

V1.05.18



WARNING!

This manual provides critical safety instructions on the proper setup, operation, maintenance, and service of this machine/tool. Save this document, refer to it often, and use it to instruct other operators.

Failure to read, understand and follow the instructions in this manual may result in fire or serious personal injury—including amputation, electrocution, or death.

The owner of this machine/tool is solely responsible for its safe use. This responsibility includes but is not limited to proper installation in a safe environment, personnel training and usage authorization, proper inspection and maintenance, manual availability and comprehension, application of safety devices, cutting/sanding/grinding tool integrity, and the usage of personal protective equipment.

The manufacturer will not be held liable for injury or property damage from negligence, improper training, machine modifications or misuse.



WARNING!

Some dust created by power sanding, sawing, grinding, drilling, and other construction activities contains chemicals known to the State of California to cause cancer, birth defects or other reproductive harm. Some examples of these chemicals are:

- **Lead from lead-based paints.**
- **Crystalline silica from bricks, cement and other masonry products.**
- **Arsenic and chromium from chemically-treated lumber.**

Your risk from these exposures varies, depending on how often you do this type of work. To reduce your exposure to these chemicals: Work in a well ventilated area, and work with approved safety equipment, such as those dust masks that are specially designed to filter out microscopic particles.

Table of Contents

INTRODUCTION.....	2	SECTION 4: OPERATIONS	21
Manual Accuracy	2	Basic Controls.....	21
Contact Info.....	2	Disabling & Locking Switch.....	22
Machine Description	2	Setup Overview.....	22
Identification.....	3	Operation Overview	22
Machine Data Sheet	4	Hold-Down Clamps.....	23
SECTION 1: SAFETY	6	Boring Head Setup	24
Safety Instructions for Machinery	6	Selecting Boring Head & Bits	24
Additional Safety for Boring Machines.....	8	Replacing Boring Head	24
SECTION 2: POWER SUPPLY	9	Installing & Adjusting Boring Bits	25
Availability.....	9	Headstock Setup.....	26
Full-Load Current Rating	9	Drilling Depth.....	27
Circuit Information	9	Setback Distance.....	27
Circuit Requirements for 110V	9	Operation.....	28
Circuit Requirements for 220V	9	Swing Arm Test Fit & Adjustment	28
Grounding Requirements	10	Fence Stop Setup.....	29
Extension Cords	10	Determining Number of Hinges	29
Voltage Conversion	11	Two-Hinge Door	30
SECTION 3: SETUP	12	Three-Hinge Door.....	30
Needed for Setup.....	12	Four-Hinge Door.....	31
Unpacking	12	SECTION 5: ACCESSORIES.....	32
Inventory	13	SECTION 6: MAINTENANCE.....	35
Cleanup.....	13	Schedule	35
Site Considerations.....	14	Cleaning.....	35
Weight Load	14	Lubrication	35
Space Allocation.....	14	Headstock Slides.....	36
Physical Environment.....	14	Depth & Throat Adjustment Shafts.....	36
Electrical Installation.....	14	Pivot Points.....	36
Lighting	14	Boring Head Assembly	36
Lifting & Placing	15	SECTION 7: SERVICE	37
Mounting	15	Troubleshooting	37
Assembly	16	Motor & Electrical	37
Dust Collection.....	19	Operation.....	38
Power Connection.....	19	SECTION 8: WIRING.....	39
Connecting Power	19	Wiring Safety Instructions	39
Disconnecting Power.....	19	Wiring Diagram	40
Test Run	20	110V Wiring.....	40
		Machine Re-wired for 220V	40
		SECTION 9: PARTS	41
		Body.....	41
		Table.....	43
		Headstock.....	44
		Handle.....	45
		Machine Labels.....	46
		WARRANTY AND RETURNS	49

INTRODUCTION

Manual Accuracy

We are proud to provide a high-quality owner's manual with your new machine!

We made every effort to be exact with the instructions, specifications, drawings, and photographs in this manual. Sometimes we make mistakes, but our policy of continuous improvement also means that **sometimes the machine you receive is slightly different than shown in the manual.**

If you find this to be the case, and the difference between the manual and machine leaves you confused or unsure about something, check our website for an updated version. We post current manuals and manual updates for free on our website at **www.grizzly.com**.

Alternatively, you can call our Technical Support for help. Before calling, make sure you write down the **Manufacture Date** and **Serial Number** from the machine ID label (see below). This information is required for us to provide proper tech support, and it helps us determine if updated documentation is available for your machine.

Grizzly Industrial MODEL GXXXX MACHINE NAME

SPECIFICATIONS	WARNING!
Motor: _____ Specification: _____ Specification: _____ Specification: _____ Weight: _____	To reduce risk of serious injury when using this machine: 1. Read manual before operation. 2. Wear safety glasses and respirator. 3. Make sure machine is properly adjusted/setup and power is connected to grounded circuit before starting. 4. Make sure the motor has stopped and disconnect power before adjustments, maintenance, or service. 5. DO NOT expose to rain or dampness. 6. DO NOT modify this machine in any way. 7. _____ 8. _____ 9. _____ 10. Maintain machine carefully to prevent accidents.

Manufacture Date: _____
Serial Number: _____

Manufactured for Grizzly in Taiwan

Contact Info

We stand behind our machines! If you have questions or need help, contact us with the information below. Before contacting, make sure you get the **serial number** and **manufacture date** from the machine ID label. This will help us help you faster.

Grizzly Technical Support
1815 W. Battlefield
Springfield, MO 65807
Phone: (570) 546-9663
Email: techsupport@grizzly.com

We want your feedback on this manual. What did you like about it? Where could it be improved? Please take a few minutes to give us feedback.

Grizzly Documentation Manager
P.O. Box 2069
Bellingham, WA 98227-2069
Email: manuals@grizzly.com

Machine Description

The Model G0718 is a production machine designed for drilling and installing European-style hinges in cabinet doors.

Grizzly offers a number of different boring heads and interchangeable boring bits (all sold separately), so the machine can be used for a wide variety of different hinge brands.

The stock machine excels at large production runs of 2-hinge doors. It is supplied with all the components necessary to make small runs of 3- or 4-hinge doors; however, an additional extension fence and stops are recommended to expedite larger or more frequent runs requiring 3 or 4 hinges.



Identification

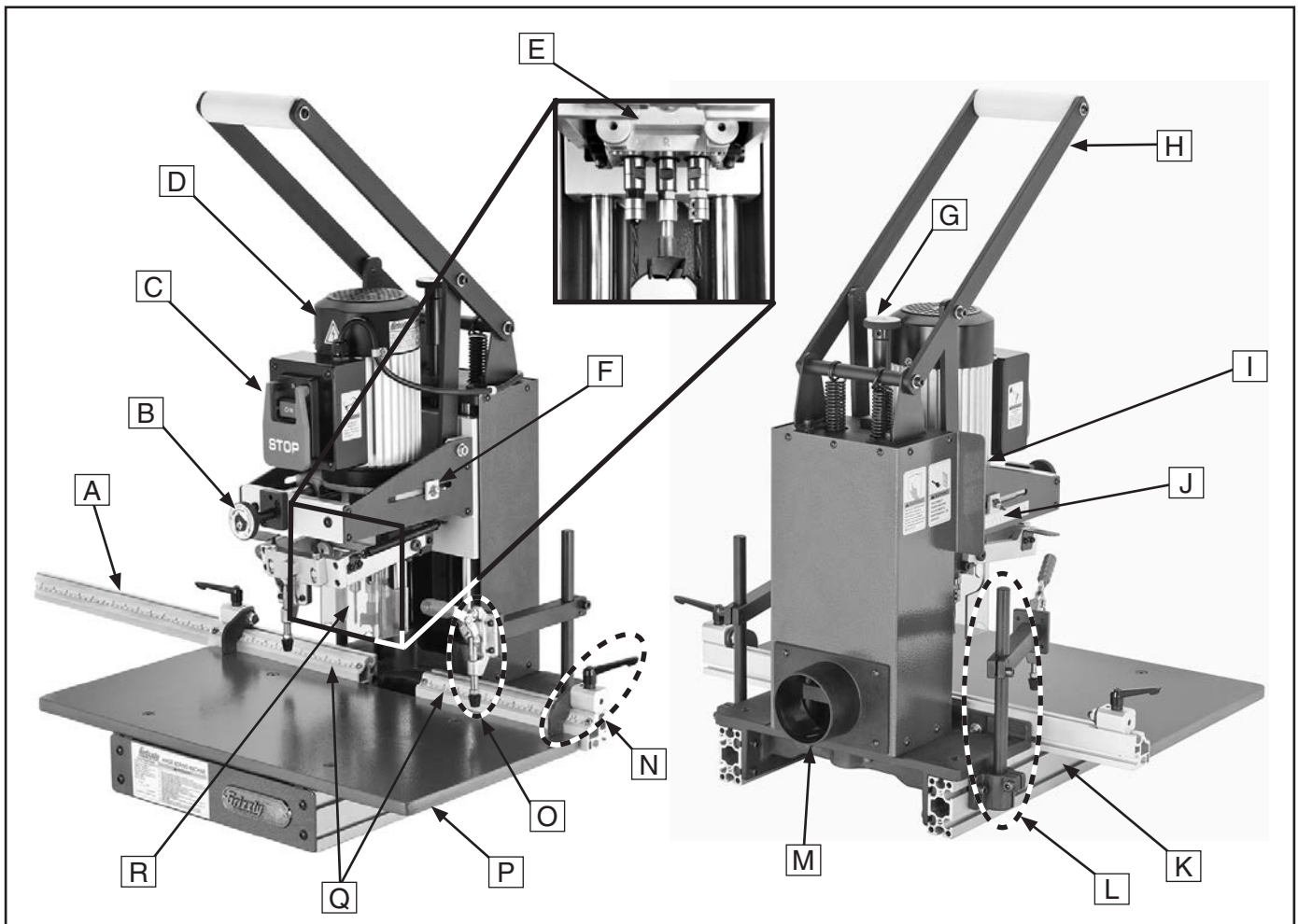

Figure 1. Model G0718 controls and features.

- | | |
|---|--|
| <ul style="list-style-type: none"> A. Fence Extension w/Left Scale B. Throat Adjustment Knob C. ON/OFF Switch Assembly D. Drive Motor E. Boring Head Assembly w/Bits (Sold Separately) F. Throat Position Lock G. Depth Adjustment Knob H. Downfeed Handle I. Depth Position Scale | <ul style="list-style-type: none"> J. Throat Position Scale K. Table Support w/Hold-Down Track L. Hold-Down Base & Arm Assembly M. 4" Dust Port N. Fence Stops O. Hold-Down Clamp P. Work Table Q. Table Fence Set R. Boring Head Guard |
|---|--|



!WARNING

To reduce your risk of serious injury, read this entire manual **BEFORE** using machine.





MACHINE DATA SHEET

© Grizzly Industrial, Inc. • Customer Service: (800) 523-4777 • Website: www.grizzly.com

MODEL G0718 HINGE BORING MACHINE

Product Dimensions:

Weight 154 lbs.
Width (side-to-side) x Depth (front-to-back) x Height 29 x 25 x 36-5/8 in.
Foot Print (Length x Width)..... 15-1/2 x 22-1/2 in.

Shipping Dimensions:

Type Cardboard Top & Wood Pallet
Content..... Machine
Weight..... 198 lbs.
Length/Width/Height..... 32 x 29 x 35 in.

Electrical:

Power Requirement 110V/220V, Single-Phase, 60 Hz
Pre-Wired Voltage..... 110V
Full-Load Current Rating..... 10A at 110V, 5A at 220V
Minimum Circuit Size 15A at 110V, 15A at 220V
Switch..... ON/OFF Switch w/Emergency Stop Paddle & Anti-Start Pin
Switch Voltage 110V/220V
Cord Length 9 ft.
Cord Gauge 14 AWG
Plug Included Yes
Included Plug Type NEMA 5-15 for 110V
Recommended Plug/Outlet Type..... NEMA 6-15 for 220V

Motors:

Main

Type..... TEFC
Horsepower 1 HP
Voltage 110V/220V
Prewired 110V
Phase Single-Phase
Amps 10/5A
Speed 3440 RPM
Cycle..... 60 Hz
Number Of Speeds..... 1
Power Transfer Direct Drive
Bearings Shielded and Permanently Sealed

Main Specifications:

Operation Information

Maximum Depth of Stroke..... 4 in.
Maximum Boring Depth from Edge..... 4 in.



Boring Bit Shaft Thread..... 10mm
 Rear Fence..... 12 in. Right, 12 in. Left
 Extension Fence.....28 in.
 Back Fence Stop.....2 Piece
 Number of Spindles on Boring Head3 Spindles (2 Left, 1 Right)

Construction

Rail Shaft Construction..... SUJ-2 High Carbon Anti-Friction Steel Slide Shaft
 Boring Head ConstructionAluminum
 Headstock Construction Sheet Metal
 Guard..... Clear PVC
 Head CarriageAluminum Alloy
 Motor Seat.....Aluminum Alloy
 Table..... Laminated MDF
 Paint Powder Coated

Other Related Information

Swing Boring Head Tolerance +/- 0.2mm
 Number of Dust Ports..... 1
 Dust Port Size 4 in.

Other Specifications:

Country Of Origin Taiwan
 Warranty..... 1 Year
 Serial Number LocationID Label on Center of the Stand
 Customer Cleanup and Assembly Time 30 Minutes

Features:

Swing boring head tolerance +/- 0.2mm
 Downfeed stroke scale position indicator
 Rear fence scale position indicator
 28" extension fence
 Manual stroke operation



SECTION 1: SAFETY

For Your Own Safety, Read Instruction Manual Before Operating This Machine

The purpose of safety symbols is to attract your attention to possible hazardous conditions. This manual uses a series of symbols and signal words intended to convey the level of importance of the safety messages. The progression of symbols is described below. Remember that safety messages by themselves do not eliminate danger and are not a substitute for proper accident prevention measures. Always use common sense and good judgment.



Indicates an imminently hazardous situation which, if not avoided, **WILL** result in death or serious injury.



Indicates a potentially hazardous situation which, if not avoided, **COULD** result in death or serious injury.



Indicates a potentially hazardous situation which, if not avoided, **MAY** result in minor or moderate injury. It may also be used to alert against unsafe practices.

NOTICE

This symbol is used to alert the user to useful information about proper operation of the machine.

Safety Instructions for Machinery



OWNER'S MANUAL. Read and understand this owner's manual **BEFORE** using machine.

TRAINED OPERATORS ONLY. Untrained operators have a higher risk of being hurt or killed. Only allow trained/supervised people to use this machine. When machine is not being used, disconnect power, remove switch keys, or lock-out machine to prevent unauthorized use—especially around children. Make your workshop kid proof!

DANGEROUS ENVIRONMENTS. Do not use machinery in areas that are wet, cluttered, or have poor lighting. Operating machinery in these areas greatly increases the risk of accidents and injury.

MENTAL ALERTNESS REQUIRED. Full mental alertness is required for safe operation of machinery. Never operate under the influence of drugs or alcohol, when tired, or when distracted.

ELECTRICAL EQUIPMENT INJURY RISKS. You can be shocked, burned, or killed by touching live electrical components or improperly grounded machinery. To reduce this risk, only allow qualified service personnel to do electrical installation or repair work, and always disconnect power before accessing or exposing electrical equipment.

DISCONNECT POWER FIRST. Always disconnect machine from power supply **BEFORE** making adjustments, changing tooling, or servicing machine. This prevents an injury risk from unintended startup or contact with live electrical components.

EYE PROTECTION. Always wear ANSI-approved safety glasses or a face shield when operating or observing machinery to reduce the risk of eye injury or blindness from flying particles. Everyday eyeglasses are **NOT** approved safety glasses.



WARNING

WEARING PROPER APPAREL. Do not wear clothing, apparel or jewelry that can become entangled in moving parts. Always tie back or cover long hair. Wear non-slip footwear to reduce risk of slipping and losing control or accidentally contacting cutting tool or moving parts.

HAZARDOUS DUST. Dust created by machinery operations may cause cancer, birth defects, or long-term respiratory damage. Be aware of dust hazards associated with each workpiece material. Always wear a NIOSH-approved respirator to reduce your risk.

HEARING PROTECTION. Always wear hearing protection when operating or observing loud machinery. Extended exposure to this noise without hearing protection can cause permanent hearing loss.

REMOVE ADJUSTING TOOLS. Tools left on machinery can become dangerous projectiles upon startup. Never leave chuck keys, wrenches, or any other tools on machine. Always verify removal before starting!

USE CORRECT TOOL FOR THE JOB. Only use this tool for its intended purpose—do not force it or an attachment to do a job for which it was not designed. Never make unapproved modifications—modifying tool or using it differently than intended may result in malfunction or mechanical failure that can lead to personal injury or death!

AWKWARD POSITIONS. Keep proper footing and balance at all times when operating machine. Do not overreach! Avoid awkward hand positions that make workpiece control difficult or increase the risk of accidental injury.

CHILDREN & BYSTANDERS. Keep children and bystanders at a safe distance from the work area. Stop using machine if they become a distraction.

GUARDS & COVERS. Guards and covers reduce accidental contact with moving parts or flying debris. Make sure they are properly installed, undamaged, and working correctly **BEFORE** operating machine.

FORCING MACHINERY. Do not force machine. It will do the job safer and better at the rate for which it was designed.

NEVER STAND ON MACHINE. Serious injury may occur if machine is tipped or if the cutting tool is unintentionally contacted.

STABLE MACHINE. Unexpected movement during operation greatly increases risk of injury or loss of control. Before starting, verify machine is stable and mobile base (if used) is locked.

USE RECOMMENDED ACCESSORIES. Consult this owner's manual or the manufacturer for recommended accessories. Using improper accessories will increase the risk of serious injury.

UNATTENDED OPERATION. To reduce the risk of accidental injury, turn machine **OFF** and ensure all moving parts completely stop before walking away. Never leave machine running while unattended.

MAINTAIN WITH CARE. Follow all maintenance instructions and lubrication schedules to keep machine in good working condition. A machine that is improperly maintained could malfunction, leading to serious personal injury or death.

DAMAGED PARTS. Regularly inspect machine for damaged, loose, or mis-adjusted parts—or any condition that could affect safe operation. Immediately repair/replace **BEFORE** operating machine. For your own safety, **DO NOT** operate machine with damaged parts!

MAINTAIN POWER CORDS. When disconnecting cord-connected machines from power, grab and pull the plug—**NOT** the cord. Pulling the cord may damage the wires inside. Do not handle cord/plug with wet hands. Avoid cord damage by keeping it away from heated surfaces, high traffic areas, harsh chemicals, and wet/damp locations.

EXPERIENCING DIFFICULTIES. If at any time you experience difficulties performing the intended operation, stop using the machine! Contact our Technical Support at (570) 546-9663.



Additional Safety for Boring Machines

WARNING

EYE/FACE/HAND PROTECTION. Debris from the drilling operation can be thrown at the operator. Always wear safety glasses or a face shield to protect your eyes and face during boring operations. The spinning boring bits are sharp and can cause serious injury. Always keep hands and fingers away from the moving bits. To reduce the risk of entanglement, **DO NOT** wear gloves when operating this machine.

GUARDS. The boring head guard reduces the risk of debris being thrown at the operator. **DO NOT** operate this machine with this guard removed.

BORING OPERATION. The boring bits rotate with tremendous torque, especially at start up. To avoid the bits grabbing the workpiece and unexpectedly moving it, never start the machine with the boring bits pressed against the workpiece.

DULL OR WORN BITS. Dull or damaged bits may break apart during operation, be thrown at the operator, or reduce the performance of the operation. Inspect bits before each use. **DO NOT** operate with dull or damaged bits.

SECURING WORKPIECE. The operator's hands may be drawn into the spinning boring bits if the workpiece moves unexpectedly during operation. Make sure the workpiece is firmly against the fence, and the workpiece is fully secured with the hold-downs.

BORING BITS. A rapidly spinning boring bit can be thrown at the operator if it comes loose from the chuck. Only use boring bits with a 10mm shank designed for this machine. Properly secure the bits in the chucks before beginning operations.

SURFACE/WORKPIECE PREPARATION. Never turn the machine **ON** before clearing the table of all tools, scrap wood, etc. Only drill wood products that are free of imperfections or foreign objects. Never use this machine to drill metal.

EXPERIENCING DIFFICULTIES. If at any time you are experiencing difficulties performing the intended operation, stop using the machine! Contact our Technical Support at (570) 546-9663.

WARNING

Like all machinery there is potential danger when operating this machine. Accidents are frequently caused by lack of familiarity or failure to pay attention. Use this machine with respect and caution to decrease the risk of operator injury. If normal safety precautions are overlooked or ignored, serious personal injury may occur.

CAUTION

No list of safety guidelines can be complete. Every shop environment is different. Always consider safety first, as it applies to your individual working conditions. Use this and other machinery with caution and respect. Failure to do so could result in serious personal injury, damage to equipment, or poor work results.



SECTION 2: POWER SUPPLY

Availability

Before installing the machine, consider the availability and proximity of the required power supply circuit. If an existing circuit does not meet the requirements for this machine, a new circuit must be installed. To minimize the risk of electrocution, fire, or equipment damage, installation work and electrical wiring must be done by an electrician or qualified service personnel in accordance with all applicable codes and standards.

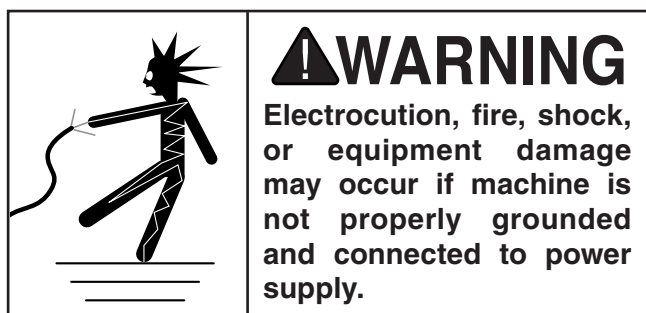

Full-Load Current Rating

The full-load current rating is the amperage a machine draws at 100% of the rated output power. On machines with multiple motors, this is the amperage drawn by the largest motor or sum of all motors and electrical devices that might operate at one time during normal operations.

Full-Load Current Rating at 110V..... 10 Amps

Full-Load Current Rating at 220V 5 Amps

The full-load current is not the maximum amount of amps that the machine will draw. If the machine is overloaded, it will draw additional amps beyond the full-load rating.

If the machine is overloaded for a sufficient length of time, damage, overheating, or fire may result—especially if connected to an undersized circuit. To reduce the risk of these hazards, avoid overloading the machine during operation and make sure it is connected to a power supply circuit that meets the specified circuit requirements.

Circuit Information

A power supply circuit includes all electrical equipment between the breaker box or fuse panel in the building and the machine. The power supply circuit used for this machine must be sized to safely handle the full-load current drawn from the machine for an extended period of time. (If this machine is connected to a circuit protected by fuses, use a time delay fuse marked D.)

⚠ CAUTION
For your own safety and protection of property, consult an electrician if you are unsure about wiring practices or electrical codes in your area.

Note: *Circuit requirements in this manual apply to a dedicated circuit—where only one machine will be running on the circuit at a time. If machine will be connected to a shared circuit where multiple machines may be running at the same time, consult an electrician or qualified service personnel to ensure circuit is properly sized for safe operation.*

Circuit Requirements for 110V

This machine is prewired to operate on a power supply circuit that has a verified ground and meets the following requirements:

Nominal Voltage 110V, 115V, 120V
Cycle 60 Hz
Phase Single-Phase
Power Supply Circuit 15 Amps
Plug/Receptacle NEMA 5-15

Circuit Requirements for 220V

This machine can be converted to operate on a power supply circuit that has a verified ground and meets the requirements listed below. (Refer to **Voltage Conversion** instructions for details.)

Nominal Voltage 208V, 220V, 230V, 240V
Cycle 60 Hz
Phase Single-Phase
Power Supply Circuit 15 Amps
Plug/Receptacle NEMA 6-15



Grounding Requirements

This machine **MUST** be grounded. In the event of certain malfunctions or breakdowns, grounding reduces the risk of electric shock by providing a path of least resistance for electric current.

For 110V operation: This machine is equipped with a power cord that has an equipment-grounding wire and a grounding plug (see following figure). The plug must only be inserted into a matching receptacle (outlet) that is properly installed and grounded in accordance with all local codes and ordinances.

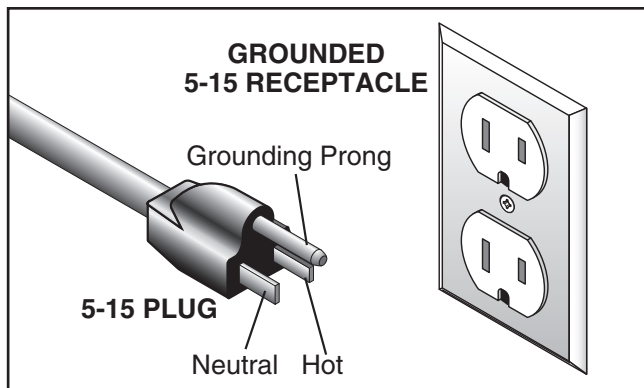

Figure 2. Typical 5-15 plug and receptacle.

⚠ CAUTION

SHOCK HAZARD!

Two-prong outlets do not meet the grounding requirements for this machine. Do not modify or use an adapter on the plug provided—if it will not fit the outlet, have a qualified electrician install the proper outlet with a verified ground.

For 220V operation: The plug specified under “Circuit Requirements for 220V” on the previous page has a grounding prong that must be attached to the equipment-grounding wire on the included power cord. The plug must only be inserted into a matching receptacle (see following figure) that is properly installed and grounded in accordance with all local codes and ordinances.

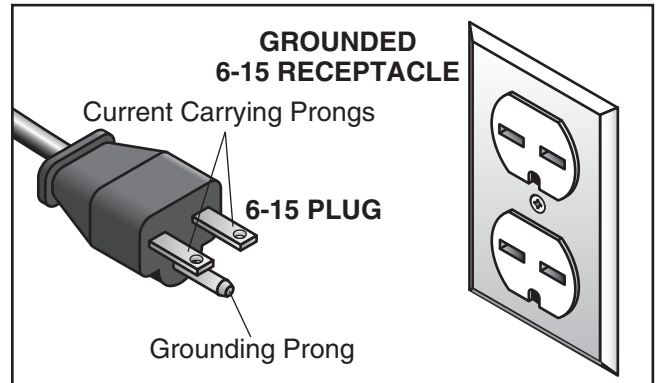

Figure 3. Typical 6-15 plug and receptacle.

Improper connection of the equipment-grounding wire can result in a risk of electric shock. The wire with green insulation (with or without yellow stripes) is the equipment-grounding wire. If repair or replacement of the power cord or plug is necessary, do not connect the equipment-grounding wire to a live (current carrying) terminal.

Check with a qualified electrician or service personnel if you do not understand these grounding requirements, or if you are in doubt about whether the tool is properly grounded. If you ever notice that a cord or plug is damaged or worn, disconnect it from power, and immediately replace it with a new one.

Extension Cords

We do not recommend using an extension cord with this machine. If you must use an extension cord, only use it if absolutely necessary and only on a temporary basis.

Extension cords cause voltage drop, which can damage electrical components and shorten motor life. Voltage drop increases as the extension cord size gets longer and the gauge size gets smaller (higher gauge numbers indicate smaller sizes).

Any extension cord used with this machine must be in good condition and contain a ground wire and matching plug/receptacle. Additionally, it must meet the following size requirements:

Minimum Gauge Size 14 AWG
Maximum Length (Shorter is Better).....50 ft.



Voltage Conversion

This section shows how to convert the Model G0718 from 110V to 220V. The plug needed for this conversion can be purchased at any local hardware store or electrical supply store.

Items Needed

	Qty
• Phillips Head Screwdriver #2	1
• NEMA 6-15 Plug	1
• Wire Cutters	1
• Wire Strippers.....	1

NOTICE

This manual was current at the time of printing; however, if the wiring diagram provided on the inside cover of the motor junction box conflicts with this manual, always use that wiring diagram instead, as it will reflect any changes that may have occurred after printing.

To convert to 220V:

1. DISCONNECT BORING MACHINE FROM POWER!
2. Cut off the pre-installed 5-15 plug from the end of the power cord.
3. Open the motor junction box (see **Figure 4**) by removing the four screws from the front.

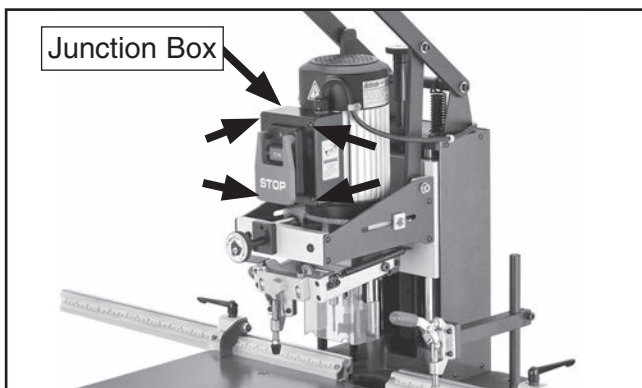

Figure 4. Motor junction box and screw locations.

4. Loosen the screws indicated in **Figure 5**.

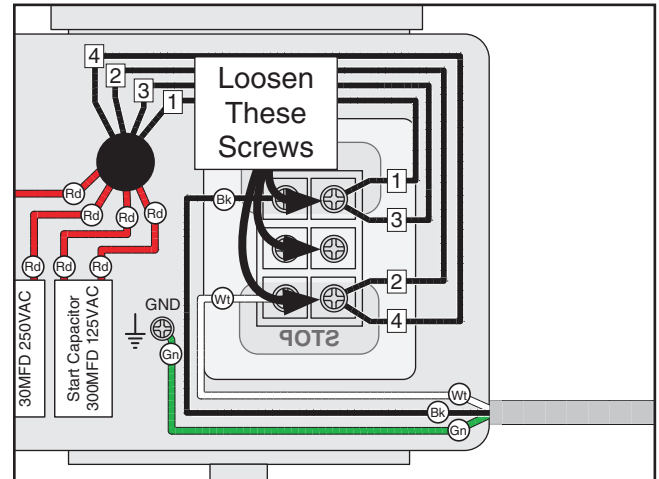

Figure 5. Location of screws to be loosened.

5. Reposition wires 1–4 as shown in **Figure 6**, then tighten the screws loosened in **Step 4**.

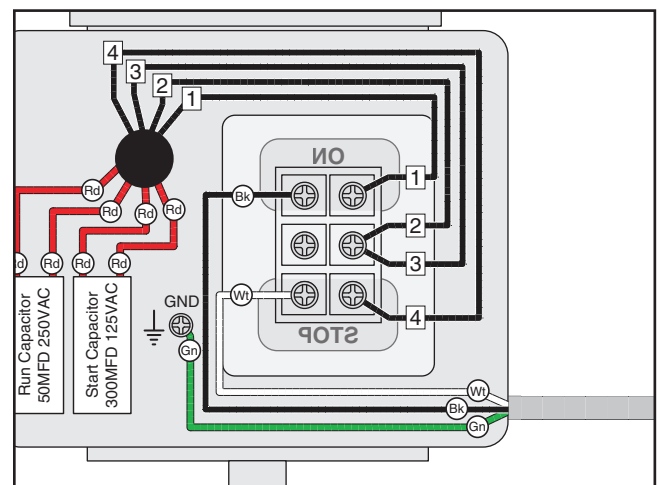

Figure 6. Motor rewired for 220V.

6. Close and secure the motor junction box.
7. Install a 6-15 plug on the end of the cord, according to the instructions and wiring diagrams provided by the plug manufacturer.

—If instructions and a wiring diagram are not provided by the plug manufacturer, the wiring diagram shown on **Page 40** shows the wiring of a standard NEMA 6-15 plug. This diagram may be used as long as your plug matches the one shown.



SECTION 3: SETUP

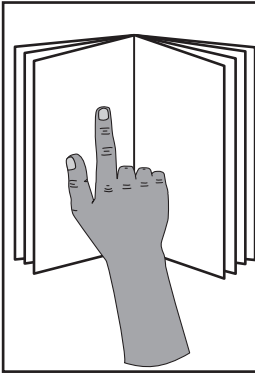

!WARNING

This machine presents serious injury hazards to untrained users. Read through this entire manual to become familiar with the controls and operations before starting the machine!

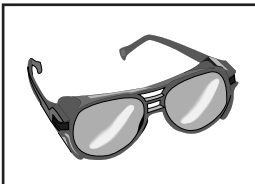

!WARNING

Wear safety glasses during the entire setup process!

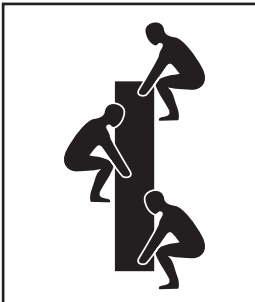

!WARNING

This machine and its components are very heavy. Get lifting help or use power lifting equipment such as a forklift to move heavy items.

Needed for Setup

The following are needed to complete the setup process, but are not included with your machine.

Description	Qty
• Safety Glasses	1
• Degreaser or Solvent for Cleaning	Varies
• Rags for Cleaning	Varies
• Minimum People Required for Lifting	3
• Screwdriver Phillips #2	1
• Dust Collection System	1
• Dust Hose 4"	1
• Hose Clamps 4"	2

Unpacking

This machine was carefully packaged for safe transport. When unpacking, separate all enclosed items from packaging materials and inspect them for shipping damage. ***If items are damaged, please call us immediately at (570) 546-9663.***

IMPORTANT: Save all packaging materials until you are completely satisfied with the machine and have resolved any issues between Grizzly or the shipping agent. ***You MUST have the original packaging to file a freight claim. It is also extremely helpful if you need to return your machine later.***

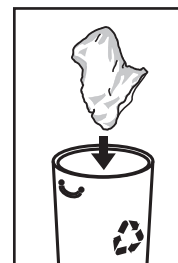

!WARNING

SUFFOCATION HAZARD!

Keep children and pets away from plastic bags or packing materials shipped with this machine. Discard immediately.



Inventory

The following is a list of items shipped with your machine. Before beginning setup, lay these items out and inventory them.

If any non-proprietary parts are missing (e.g. a nut or a washer), we will gladly replace them; or for the sake of expediency, replacements can be obtained at your local hardware store.

Box 1: (Figure 7)	Qty
A. Boring Machine (Not Shown)	1
B. Fence Extension w/Scale	1
C. Right Scale (14 ¹⁵ / ₁₆ "–42")	1
D. Dust Port 4"	1
E. Boring Head Guard	1
F. Swing Arm Assembly	1
G. Open-End Wrench 14/17mm	1
H. Open-End Wrench 12/14mm	1
I. Open-End Wrench 11/13mm	1
J. Cap Screws M6-1 x 65	4
K. Cap Screws M6-1 x 55	2
L. Cap Screws M6-1 x 45	2
M. Hex Wrench Set 1.5, 2, 2.5, 3, 4, 5, 6, 8, & 10mm.....	1 Each

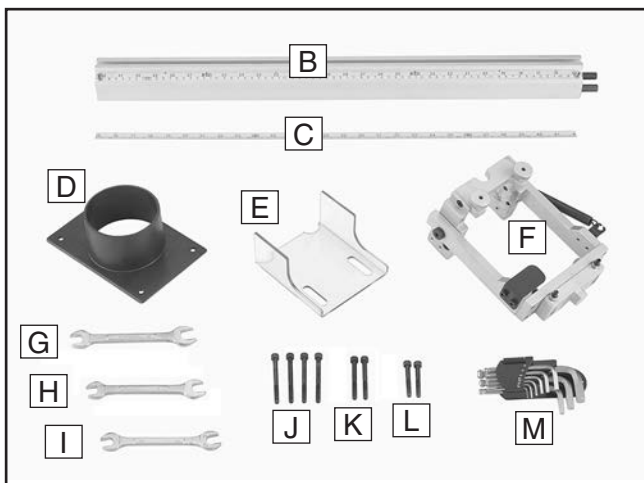

Figure 7. Inventory.

Cleanup

The unpainted surfaces of your machine are coated with a heavy-duty rust preventative that prevents corrosion during shipment and storage. This rust preventative works extremely well, but it will take a little time to clean.

Be patient and do a thorough job cleaning your machine. The time you spend doing this now will give you a better appreciation for the proper care of your machine's unpainted surfaces.

There are many ways to remove this rust preventative, but the following steps work well in a wide variety of situations. Always follow the manufacturer's instructions with any cleaning product you use and make sure you work in a well-ventilated area to minimize exposure to toxic fumes.

Before cleaning, gather the following:

- Disposable rags
- Cleaner/degreaser (WD•40 works well)
- Safety glasses & disposable gloves
- Plastic paint scraper (optional)

Basic steps for removing rust preventative:

1. Put on safety glasses.
2. Coat the rust preventative with a liberal amount of cleaner/degreaser, then let it soak for 5–10 minutes.
3. Wipe off the surfaces. If your cleaner/degreaser is effective, the rust preventative will wipe off easily. If you have a plastic paint scraper, scrape off as much as you can first, then wipe off the rest with the rag.
4. Repeat **Steps 2–3** as necessary until clean, then coat all unpainted surfaces with a quality metal protectant to prevent rust.

NOTICE

Avoid chlorine-based solvents, such as acetone or brake parts cleaner, that may damage painted surfaces.



Site Considerations

Weight Load

Refer to the **Machine Data Sheet** for the weight of your machine. Make sure that the surface upon which the machine is placed will bear the weight of the machine, additional equipment that may be installed on the machine, and the heaviest workpiece that will be used. Additionally, consider the weight of the operator and any dynamic loading that may occur when operating the machine.

Space Allocation

Consider the largest size of workpiece that will be processed through this machine and provide enough space around the machine for adequate operator material handling or the installation of auxiliary equipment. With permanent installations, leave enough space around the machine to open or remove doors/covers as required by the maintenance and service described in this manual.

See below for required space allocation.



Physical Environment

The physical environment where the machine is operated is important for safe operation and longevity of machine components. For best results, operate this machine in a dry environment that is free from excessive moisture, hazardous chemicals, airborne abrasives, or extreme conditions. Extreme conditions for this type of machinery are generally those where the ambient temperature range exceeds 41°–104°F; the relative humidity range exceeds 20%–95% (non-condensing); or the environment is subject to vibration, shocks, or bumps.

Electrical Installation

Place this machine near an existing power source. Make sure all power cords are protected from traffic, material handling, moisture, chemicals, or other hazards. Make sure to leave enough space around machine to disconnect power supply or apply a lockout/tagout device, if required.

Lighting

Lighting around the machine must be adequate enough that operations can be performed safely. Shadows, glare, or strobe effects that may distract or impede the operator must be eliminated.

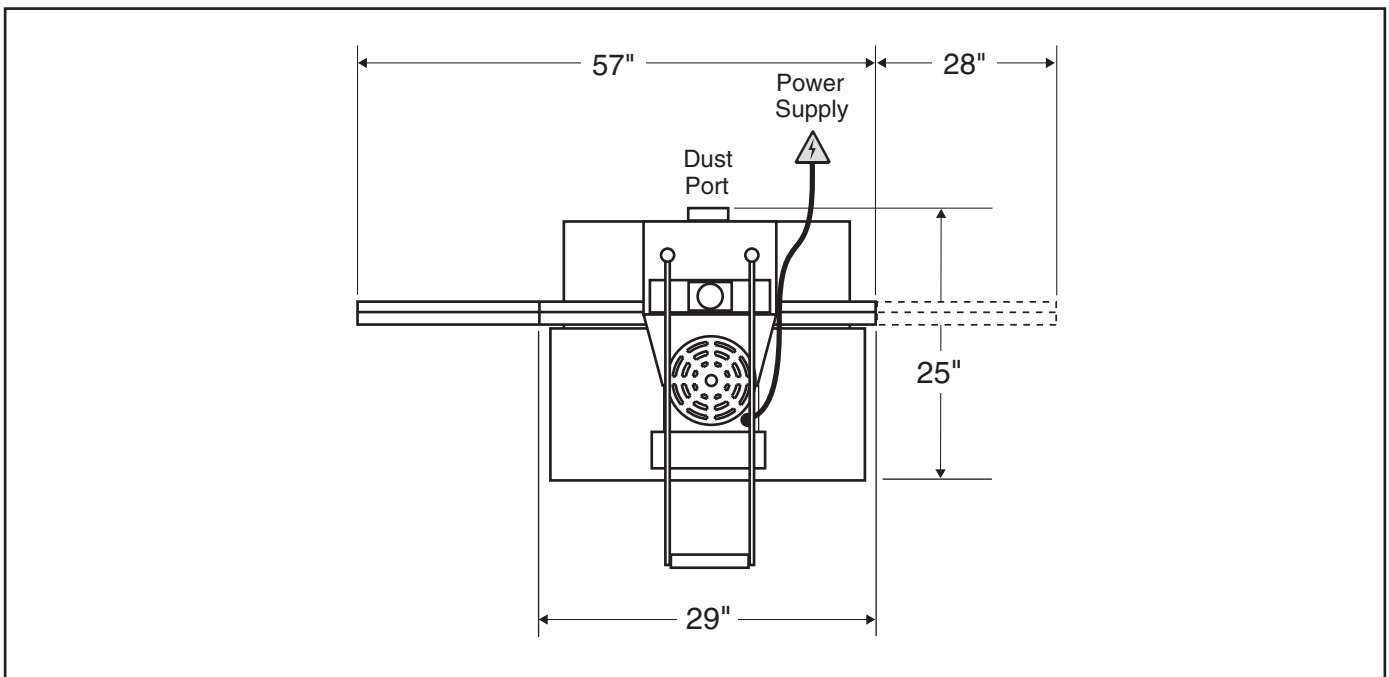
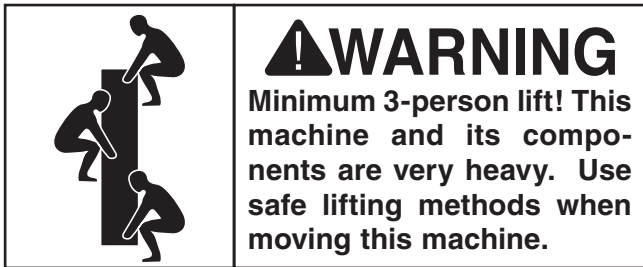

Figure 8. Minimum working clearances.



Lifting & Placing



To lift and place your boring machine:

1. Prepare the location for the boring machine per **Circuit Requirements** on **Page 9** and **Site Considerations** on **Page 14**.
2. Unbolt the machine from the shipping crate.
3. Lift from each side of the work table, and move the machine to its prepared location.

Mounting

The base of this machine has mounting holes that allow it to be fastened to a workbench or other mounting surface to prevent it from moving during operation and causing accidental injury or damage.

The strongest mounting option is a "Through Mount" (see example below) where holes are drilled all the way through the workbench—and hex bolts, washers, and hex nuts are used to secure the machine in place.

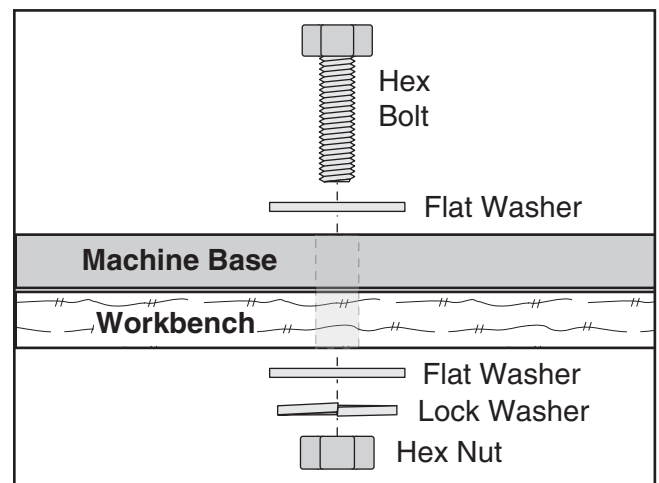

Figure 9. "Through Mount" setup.

Another option is a "direct mount" (see example below) where the machine is secured directly to the workbench with lag screws and washers.

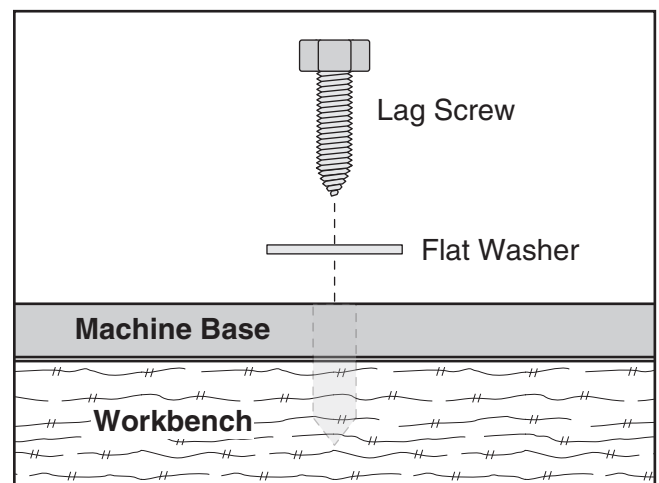

Figure 10. "Direct Mount" setup.



Assembly

The handle was secured to the machine in a special way to protect it from shipping damage. As such, the way it is mounted for shipping is not how it should be mounted for operation. The assembly process involves re-mounting the handle in its operating position and installing all loose components from the shipping box.

The machine requires, but does not include, a boring head in order to perform operations. Grizzly offers a number of boring heads for this machine (refer to **Page 32** for more details). The boring head must be installed before performing the **Test Run** procedure. To choose the correct boring head, refer to **Selecting Boring Head on Page 24**.

!WARNING

Serious personal injury could occur if you connect the machine to power before completing the setup process. DO NOT connect power until instructed later in this manual.

To assemble your boring machine:

1. DISCONNECT BORING MACHINE FROM POWER!
2. Remove and discard the cable ties that secure the downfeed handle (see **Figure 11**).

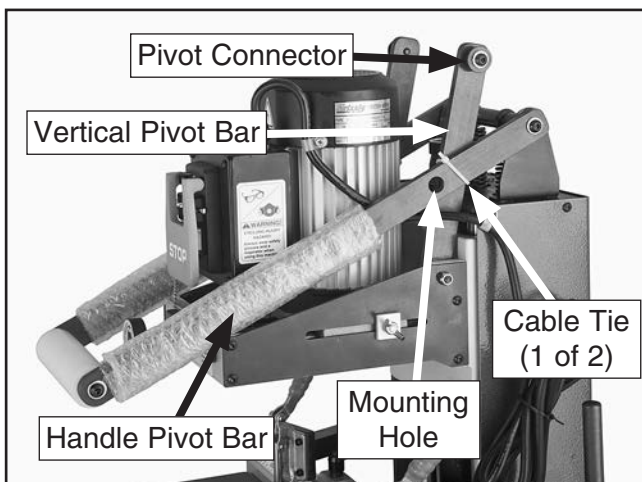

Figure 11. Cable ties and pivot connector.

3. Remove the fasteners from the pivot connector (see **Figure 11**), raise the handle pivot bar, and use the fasteners to secure the handle pivot bar to the vertical pivot bar through the mounting holes shown.
4. Loosen the cap screws on the fence extension rods, slide the rods out about half their length (see **Figure 12**), then tighten two of the screws to secure the rods to the extension.

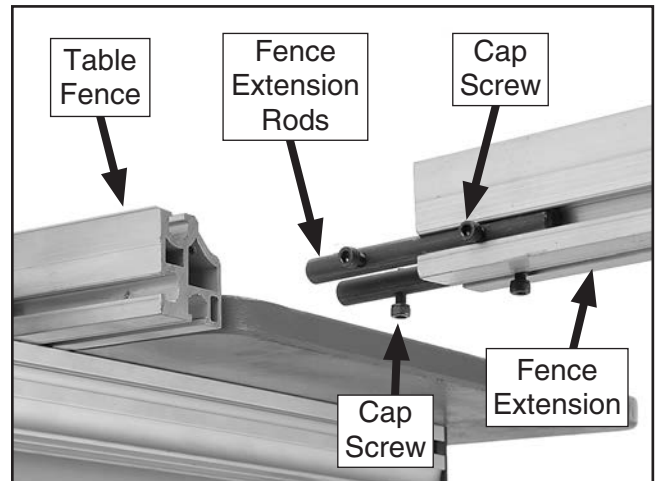

Figure 12. Fence extension rods and cap screws (shown from right rear of table).

Note: The fence extension is only needed for certain applications, such as 3-hinge doors. Therefore, installation is optional depending on anticipated needs.

The fence extension can be mounted on the left or right end of the table fence for different applications. If mounting the fence extension on the right side, you must swap the left scale on the fence extension with the provided right scale. This ensures the numbering sequence between the table fence scale and the fence extension scale are congruent.



- Slide the fence extension rods into the table fence, then tighten the cap screws to hold the fence extension in place (see **Figure 13**).

Note: If you decide not to install the fence extension at this time, it can be set aside with the extension rods and stored for later use.



Figure 13. Fence extension installed.

- Install the dust port.

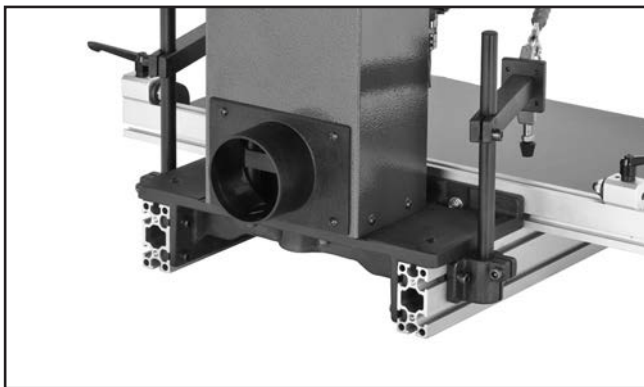

Figure 14. Dust port installed.

- Mount the boring head to the spindle, making sure the slot in the boring head shaft (see **Figure 15**) is aligned with the tang in the spindle.

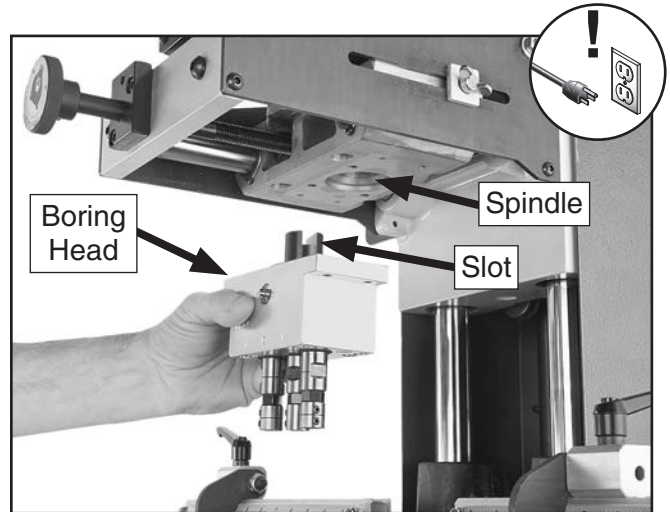

Figure 15. Installing boring head on spindle.

- Secure the boring head with (4) M6-1 x 65 cap screws at the inside holes shown in **Figure 16**.

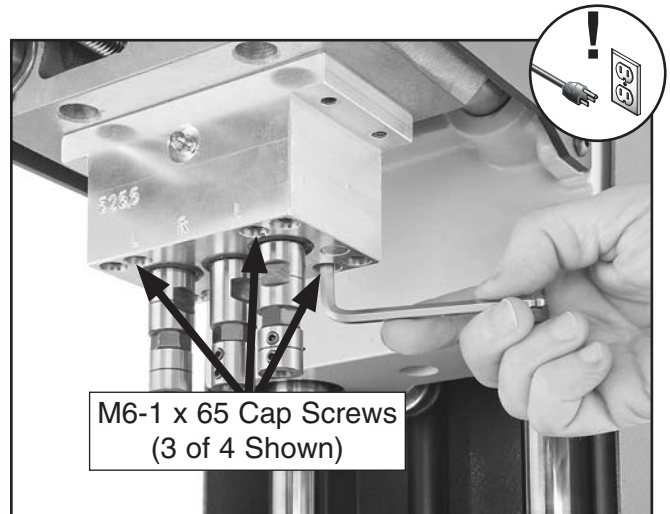

Figure 16. Securing boring head to machine.



9. Slide the swing arm assembly over the boring head (see **Figure 17**).

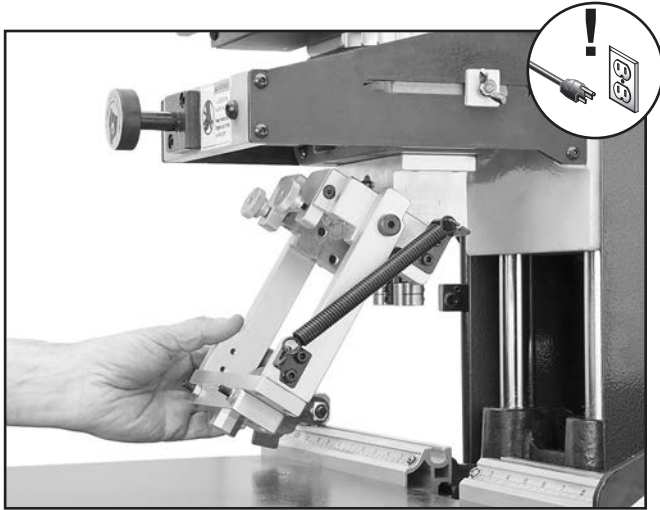

Figure 17. Sliding swing arm onto boring head.

10. Pivot the swing arm up and secure both sides of the swing arm assembly to the head with (2) M6-1 x 45 cap screws and (2) M6-1 x 55 cap screws, using each size where shown in **Figure 18**.

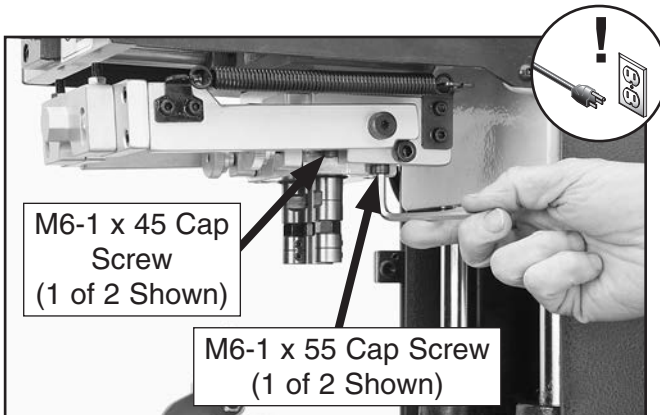

Figure 18. Securing swing arm assembly.

11. Pivot the swing arm down.

12. Remove the swing arm handle, which is pre-installed backwards for shipping purposes, then re-install it as shown in **Figure 19**.



Figure 19. Installing swing arm handle.

13. Install the clear guard (see **Figure 20**) with the knurled knobs.

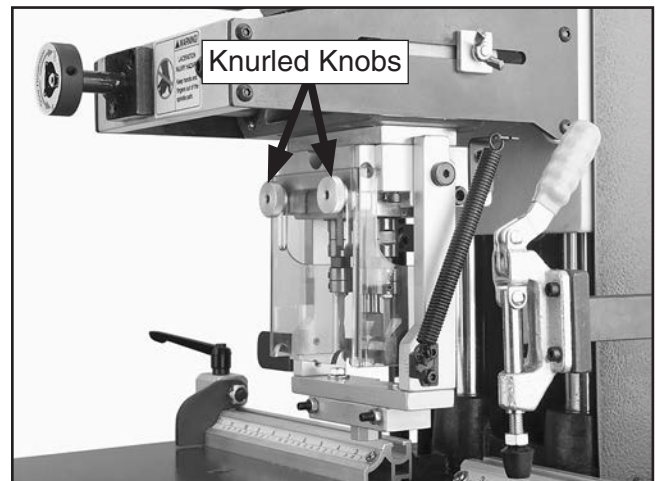

Figure 20. Clear guard installed.



Dust Collection

CAUTION

DO NOT operate the Model G0718 without an adequate dust collection system. This machine creates substantial amounts of wood dust while operating. Failure to use a dust collection system can result in short and long-term respiratory illness.

Recommended CFM at Dust Port: 400 CFM

Do not confuse this CFM recommendation with the rating of the dust collector. To determine the CFM at the dust port, you must consider these variables: (1) CFM rating of the dust collector, (2) hose type and length between the dust collector and the machine, (3) number of branches or wyes, and (4) amount of other open lines throughout the system. Explaining how to calculate these variables is beyond the scope of this manual. Consult an expert or purchase a good dust collection "how-to" book.

To connect a dust collection hose:

1. Fit the 4" dust hose over the dust port and secure it in place with a hose clamp.
2. Tug the hose to make sure it does not come off.

Note: *A tight fit is necessary for proper performance.*

Power Connection

After you have completed all previous setup instructions and circuit requirements, the machine is ready to be connected to the power supply.

To avoid unexpected startups or property damage, use the following steps whenever connecting or disconnecting the machine from the power

Connecting Power

1. Turn the machine power switch **OFF**.
2. Insert the power cord plug into a matching power supply receptacle. The machine is now connected to the power source.

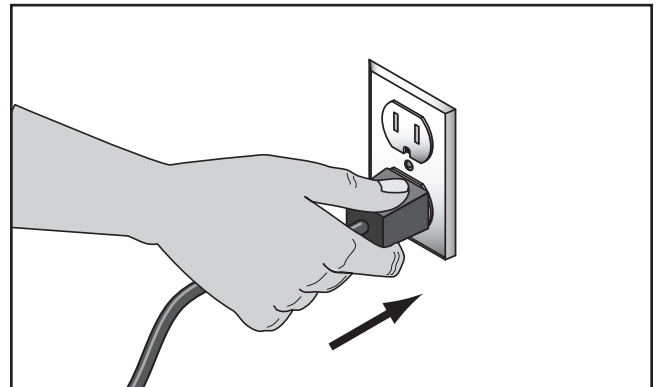

Figure 21. Connecting power.

Disconnecting Power

1. Turn the machine power switch **OFF**.
2. Grasp the molded plug and pull it completely out of the receptacle. **DO NOT** pull by the cord as this may damage the wires inside.

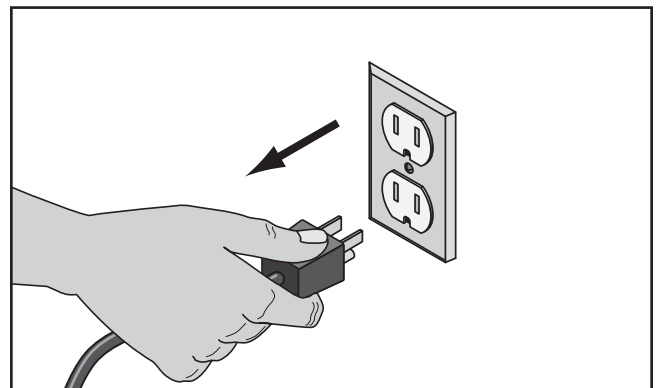

Figure 22. Disconnecting power.



Test Run

Once assembly is complete, test run the machine to ensure it is properly connected to power and safety components are functioning correctly.

If you find an unusual problem during the test run, immediately stop the machine, disconnect it from power, and fix the problem **BEFORE** operating the machine again. The **Troubleshooting** table in the **SERVICE** section of this manual can help.

The test run consists of verifying the following:

- 1) The motor powers up and runs correctly, and
- 2) the safety disabling mechanism on the switch works correctly.

To test run the machine:

1. Read and follow the safety instructions at the beginning of the manual, and make sure the machine is setup properly.
2. Make sure all tools and objects used during set up are cleared away from the machine.
3. Verify that the machine is operating correctly by turning it **ON**.

—When operating correctly, the machine runs smoothly with little or no vibration, rubbing, or grinding noises. Check to make sure that all chucks rotate. If they do not rotate, call Tech Support for help.

—Investigate and correct strange or unusual noises or vibrations before operating the machine further. Always disconnect the machine from power when investigating or correcting potential problems.

4. Turn the machine **OFF**.
5. Insert the switch disabling pin through the green ON button, as shown in **Figure 23**.



Figure 23. Switch disabling pin installed.

6. Press the green ON button to test the disabling feature on the switch.

—If the machine does not start, the switch disabling feature is working as designed.

—If the machine starts, immediately stop the machine. The switch disabling feature is not working correctly. This safety feature must work properly before proceeding with regular operations. Call Tech Support for help.



SECTION 4: OPERATIONS

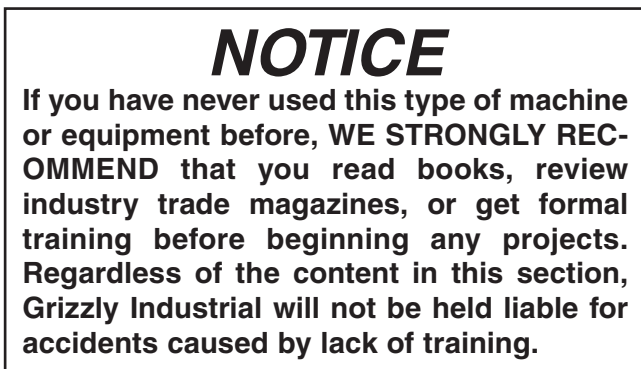
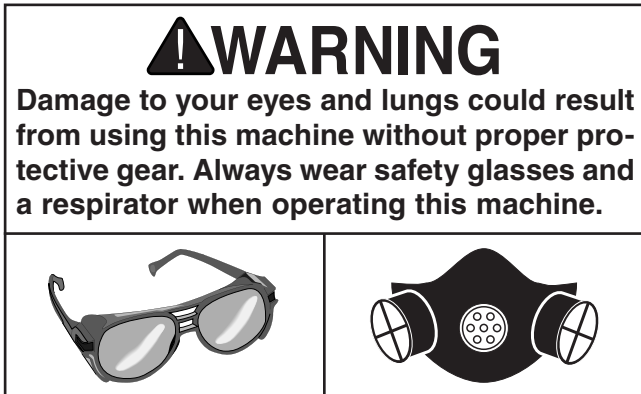
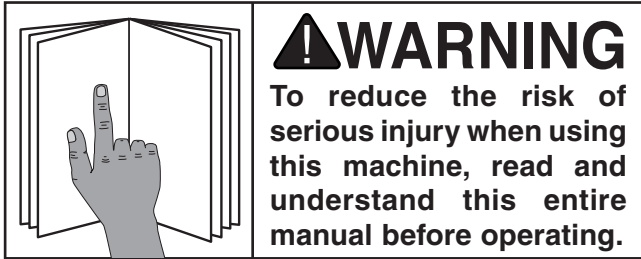

Basic Controls

Refer to **Figure 24** and the following descriptions to become familiar with the basic controls of this machine.

- A. ON/OFF Switch:** Starts and stops motor.
- B. Downfeed Handle:** Raises and lowers boring bits for drilling operations.
- C. Depth Adjustment Knob:** Sets the maximum boring bit depth.

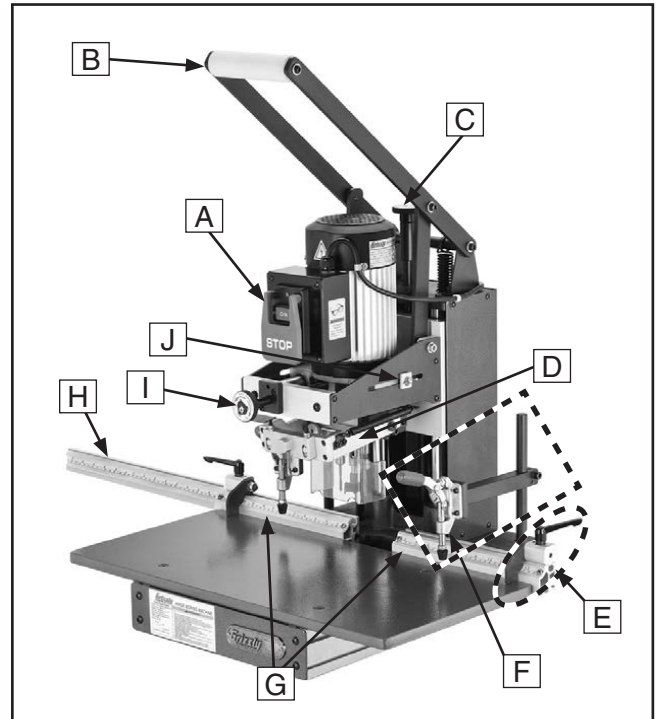

Figure 24. Model G0718 basic controls.

- D. Swing Arm:** Swings down after boring operation to install hinge.
- E. Fence Stops:** Mount anywhere along the fence so holes can be drilled in multiple workpieces at the same location.
- F. Hold-Down Clamp:** Secures the workpiece firmly against the table and fence. Adjusts to accommodate different workpiece thicknesses.
- G. Table Fence:** The two-piece fence supports the workpiece during the boring operation. The fence scale is used to position the workpiece relative to the boring bits.
- H. Fence Extension:** Mounts on the left or right end of the table fence for longer workpieces.
- I. Throat Adjustment Knob:** Adjusts the boring head bit position laterally.
- J. Throat Position Lock:** Locks the boring head lateral position when adjusting the set-back distance.



Disabling & Locking Switch

The switch can be disabled and locked by inserting a padlock through the ON/START button, as shown. Locking the switch in this manner can prevent unauthorized operation of the machine, which is especially important if the machine is not stored inside an access-restricted building.

IMPORTANT: Locking the switch with a padlock only restricts its function. It is not a substitute for disconnecting power from the machine when adjusting or servicing.

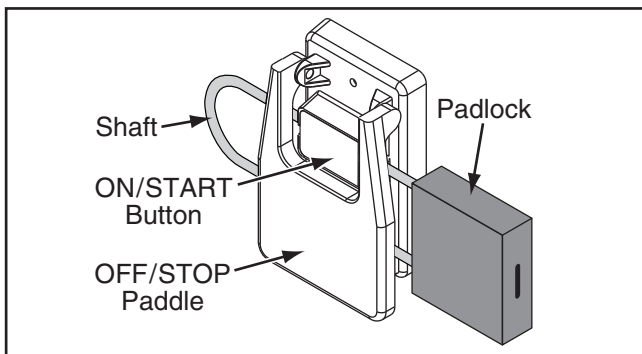

Figure 25. Switch disabled by a padlock.

!WARNING

Children or untrained people can be seriously injured by this machine. This risk increases with unsupervised operation. To help prevent unsupervised operation, disable and lock the switch before leaving machine unattended! Place key in a well-hidden or secure location.

NOTICE

The padlock shaft diameter is important to the disabling function of the switch. With any padlock used to lock the switch, test the switch after installation to ensure that it is properly disabled.

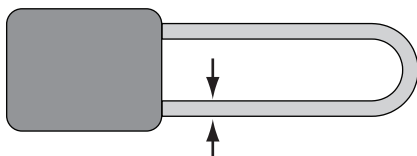

Figure 26. Minimum lock shaft requirements.

Setup Overview

The purpose of this overview is to provide the machine operator a basic understanding of how the machine is set up for most operations.

To set up the Model G0718, the operator does the following:

1. Selects the specific cabinet door thickness and hinge size.
2. Adjusts the hold-down clamps to the thickness of the cabinet door.
3. Installs the correct boring head and bits for the hinge type.
4. Adjusts the boring depth and setback position for the size of hinge to be installed.
5. Adjusts the fence stops for the cabinet door size and location of the hinge mounting holes.

Operation Overview

The purpose of this overview is to provide the novice machine operator with a basic understanding of how the machine is used during operation, so the machine controls/components discussed later in this manual are easier to understand.

To complete a typical operation, the operator does the following:

1. Positions the fence stops along the left and right fences so they are both spaced the same distance away from the center of the cup bit, and then locks them in place.
2. Pivots one of the fence stops out of the way.
3. Places the cabinet door upside down on the table, with the hinge side firmly and evenly against the table fences, and one edge against the remaining fence stop.



4. Secures the cabinet door with a hold-down clamp.
5. Turns the machine **ON**.

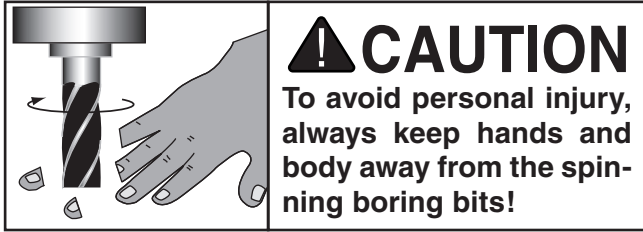

6. Uses the downfeed handle to lower the boring bits into the workpiece, drills the hole, then raises the downfeed handle all the way up.
7. Turns the machine **OFF**.
8. Places the hinge on the swing arm ram, lowers the swing arm, inserts the hinge into the cup hole, then raises the swing arm all the way up.
9. Unclamps the cabinet door, pivots the last used fence stop out of the way, and pivots the previously unused fence stop to the table side.
10. Repeats **Steps 3–8** to drill additional mounting holes and install hinges.

Hold-Down Clamps

The hold-down clamps are used to hold the cabinet door firmly against the table and fence during boring operations. They are adjustable to accommodate the thickness of the cabinet door, which is typically between $\frac{5}{8}$ " and $\frac{3}{4}$ " thick.

Tools Needed	Qty
Hex Wrench 3mm.....	1
Hex Wrench 6mm.....	1

To adjust the hold-downs:

1. DISCONNECT BORING MACHINE FROM POWER!
2. Loosen the cap screw and set screw (see **Figure 27**) and adjust the hold-down so the foot just touches the cabinet door and the handle is parallel to the table, then push the handle down to check clamping pressure. Adjust as necessary until correct.

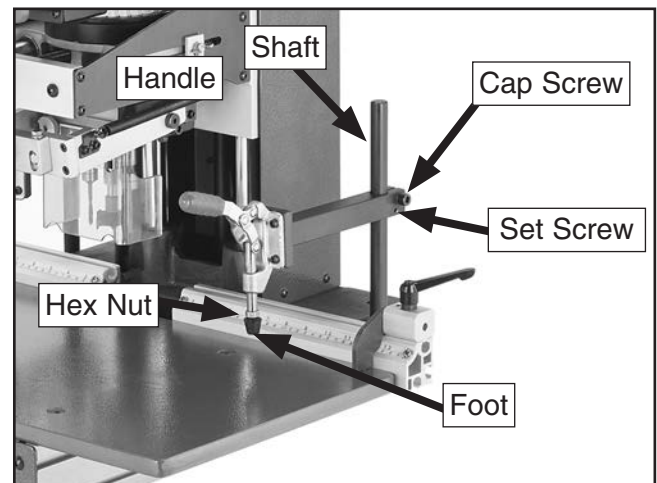

Figure 27. Hold-down assembly.

3. Secure the cap screw and set screw, then recheck clamping pressure.

Note: *If the foot presses too loose or too tight against the board, loosen the hex nut above the foot, and adjust the foot as needed, then tighten the hex nut against the foot.*



Boring Head Setup

Many Euro-style cabinet hinge styles are available, but not all can be used with this machine. Your hinge must fit the three-hole pattern drilled by one of three boring heads designed for this machine. Also, the hinge mounting holes should fit one of the three bit sizes.

Tools Needed	Qty
Small Flat Head Screwdriver	1
Hex Wrench 2.5mm.....	1
Hex Wrench 5mm.....	1

Selecting Boring Head & Bits

Measure (A) the center-to-center distance between hinge mounting holes, and (B) the distance between the center line of the hinge cup and a mounting hole (see **Figure 28**). Refer to **Accessories, Page 32** for boring head models.

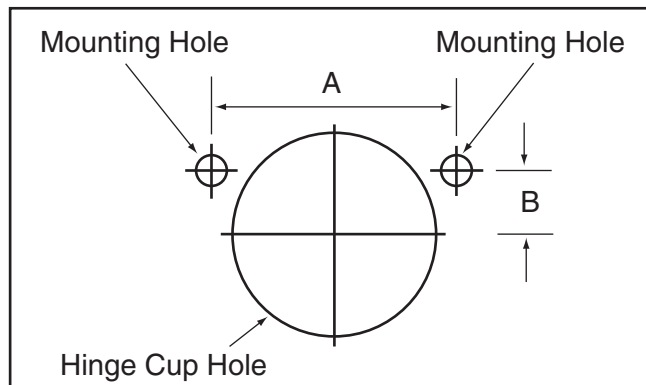

Figure 28. Dimensions required for matching hinge to boring head.

The Model G0718 accepts two pilot bits and a cup bit, as shown in **Figure 29**.

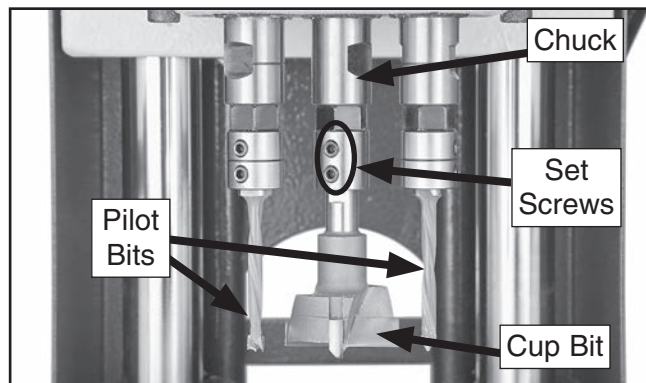

Figure 29. Chucks with boring bits installed (guard removed for clarity).

The pilot bits drill the hinge mounting holes, as shown in **Figure 30**.

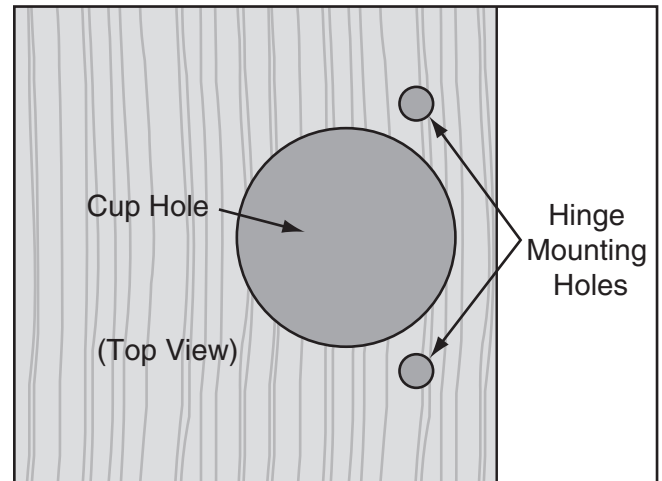

Figure 30. Holes drilled in workpiece by boring bits.

The diameter of the pilot bits, either 3, 8, or 10 mm, determines the diameter of the hinge mounting hole. The 35mm cup bit drills the center cup hole.

Because mounting hole sizes vary depending upon the hinge used, boring bits must be purchased separately. Refer to **Accessories** on **Page 32** for further details.

Replacing Boring Head

Replace the boring head if you need to use one with a different drilling pattern.

To replace the boring head:

1. DISCONNECT BORING MACHINE FROM POWER!
2. Remove the clear guard and the boring bits.
3. Pivot the swing arm up.



- Remove the (2) M6-1 x 45 and (2) M6-1 x 55 cap screws from both sides of the swing arm assembly, then slide the swing arm off the head.

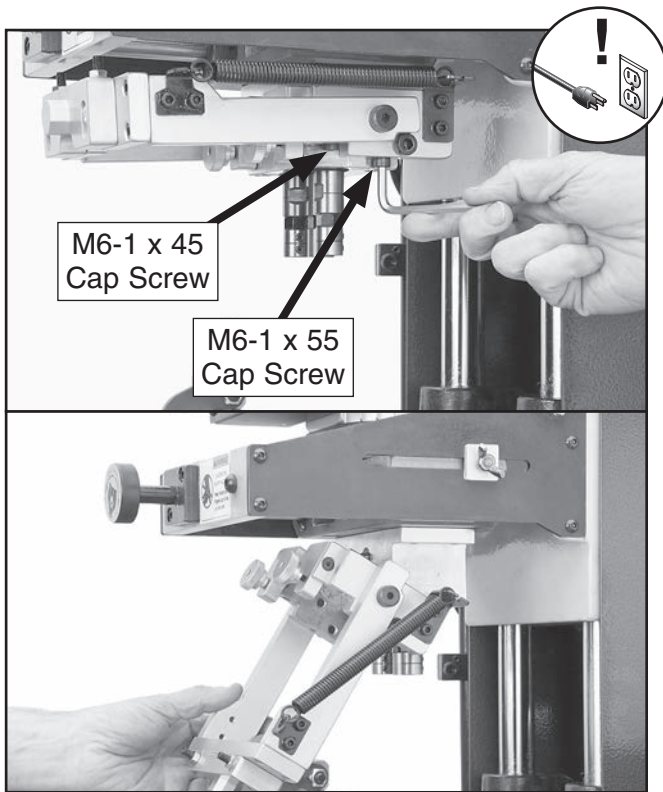

Figure 31. Removing swing arm assembly

- Remove the (4) M6-1 x 65 cap screws at the inside holes shown in **Figure 32**, then remove the boring head from the spindle.

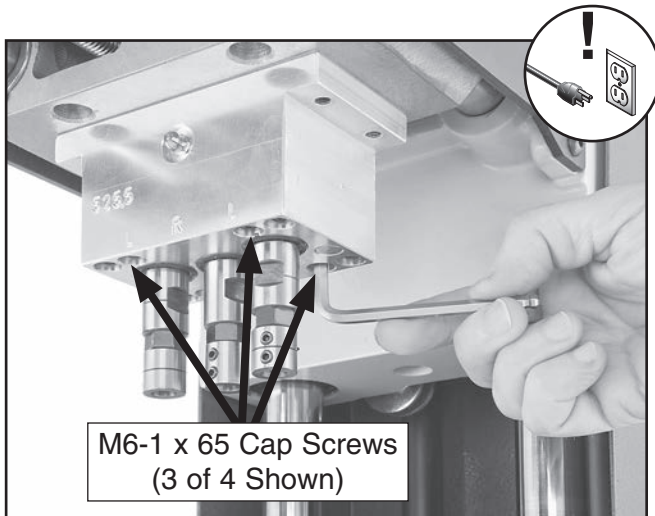

Figure 32. Removing inner cap screws.

- Install the new boring head in the reverse order or removal.

Installing & Adjusting Boring Bits

Boring bits have a flat surface on the shank (see **Figure 33**) to facilitate easy and secure mounting, and they have an adjusting screw for offsetting the drilling depth in relation to the other bits.

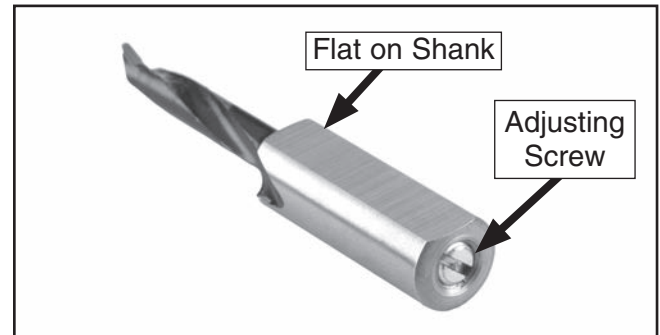

Figure 33. Boring bit.

To install boring bits:

- DISCONNECT BORING MACHINE FROM POWER!
- Remove the clear guard.
- Position the adjusting screws on all of the bits (see **Figure 33**) even with the top of the bit housing.

This sets the bottom of the bits flush so all the holes are drilled at the same depth, as shown in **Figure 34**. The tips of the mounting screws thread into the workpiece slightly below the cup. This setting works well for most hinges.

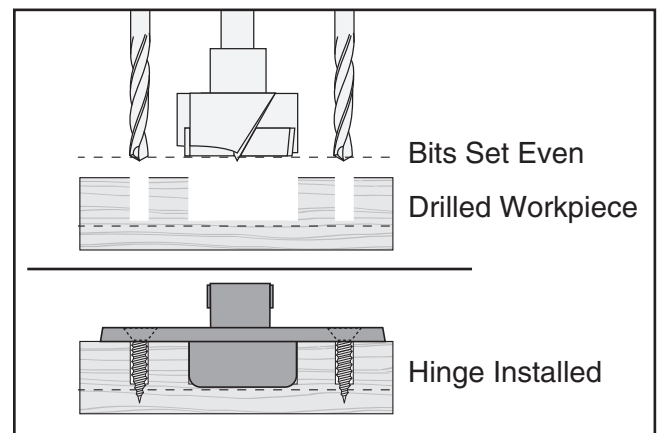

Figure 34. Hinge bits set even, holes drilled in workpiece, hinge installed.



Note: The adjusting screws can be turned in or out as needed to adjust the depth of the cup hole or pilot holes in relation to each other.

- Loosen the set screws on all the chucks (see **Figure 35**).

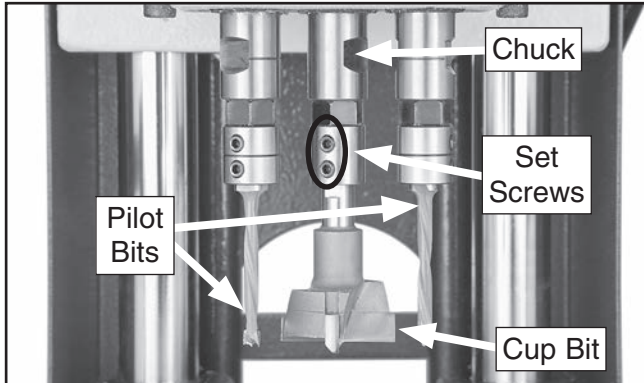

Figure 35. Chucks with boring bits installed.

- Align the flat part of the bits with the chuck set screws, slide them all the way into the chuck, then tighten the set screws.
- Re-install the clear guard onto the boring head assembly.

Headstock Setup

Before using the Model G0718 to drill holes in an actual cabinet door, you need to set up the boring head. This includes adjusting the drilling depth, setback, and swing arm ram, then performing a test cut and fitting.

The drilling depth is adjusted using the depth adjustment knob, shown in **Figure 36**. Setback, the distance between the cabinet door edge and hinge hole, as shown in **Figure 37**, is adjusted using the throat adjustment knob.

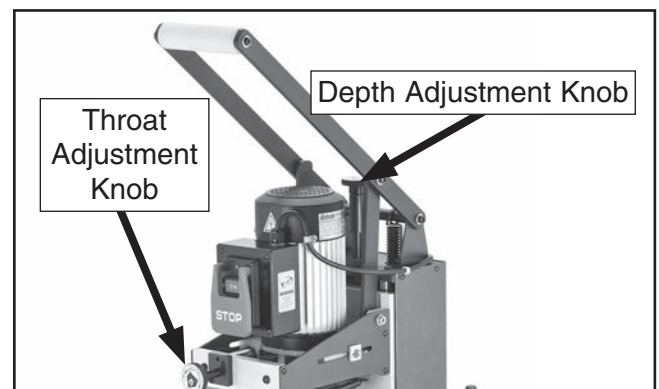

Figure 36. Depth adjustment knob.

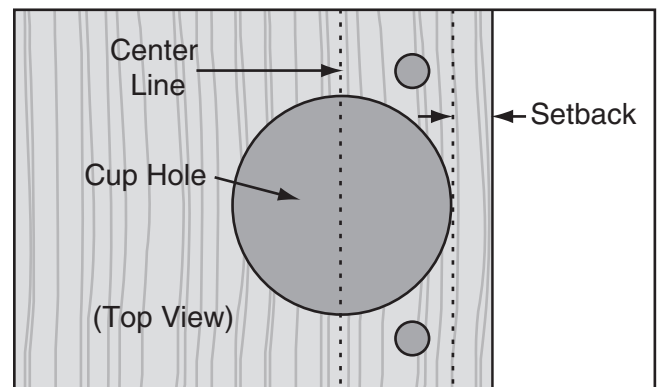

Figure 37. Determining setback & center line.

The swing arm is used as an easy way to insert the hinge into the newly drilled cup hole.

The swing arm block needs to be adjusted to ensure the hinge mounting holes align with the holes drilled by the pilot bits for repeatable production runs.



Items Needed	Qty
Scrap Board (Same Thickness as Workpiece and at least 12" long).....	1
Ruler.....	1
Hex Wrench 3mm.....	1
Wrench 10mm.....	1

Drilling Depth

1. DISCONNECT BORING MACHINE FROM POWER!
2. Place a hinge against the edge of the scrap board and mark the hinge cup depth on the side of the board, as shown in **Figure 38**.

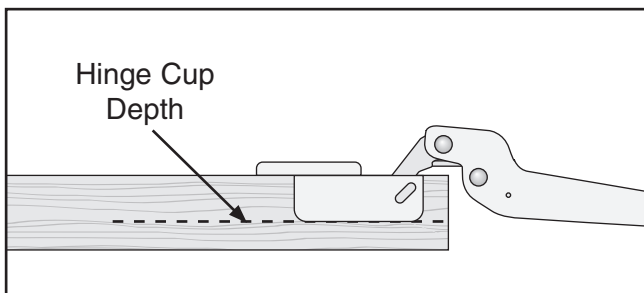

Figure 38. Hinge cup bottom depth marked on scrap board.

3. Place the scrap board flush against the table and the fence.
4. Lower the boring head, then turn the depth adjustment knob as needed until the cup bit or a pilot bit is aligned with the mark on the scrap board (see **Figure 39**), then remove the scrap board.

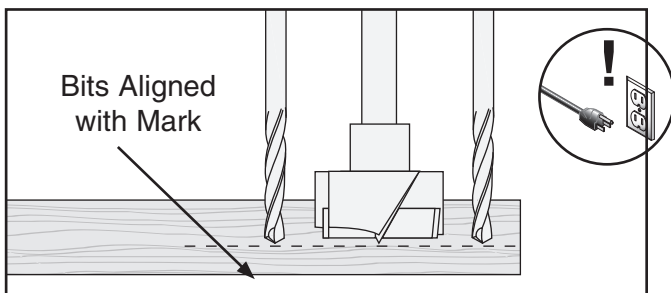

Figure 39. Bit aligned with depth mark.

Note: If the hinge requires the pilot holes to be deeper or shallower than the cup hole, adjust the individual bit depths as necessary at this time (refer to **Installing Boring Bits on Page 25**).

Setback Distance

1. Determine the amount of setback required (see **Figure 37**), then mark it on the scrap board.

Note: Refer to the hinge manufacturer's instructions for the setback distance. Setback usually ranges from $\frac{1}{8}$ " to $\frac{1}{4}$ ".

2. Mark the hinge cup center line, as illustrated in **Figure 40**. In this example, the center line is 17.5mm from the setback, which itself is $\frac{1}{4}$ " from the cabinet door edge.

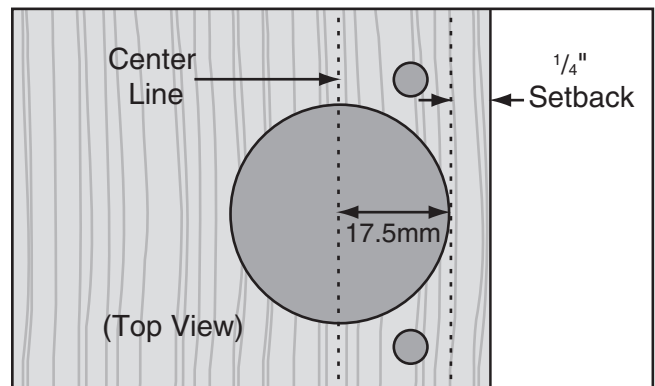

Figure 40. Example of marking setback and centerline.

3. Place the scrap board against the table and fence.
4. Lower the downfeed handle, then use the lateral adjustment knob to align the tip of the cup bit to the centerline.



Operation

1. Secure the scrap board with the hold-down clamps (refer to **Hold-Down Clamps** on **Page 23**).
2. Connect the machine to power.
3. Turn the boring machine **ON**, then lower the downfeed handle completely to drill the hinge cup hole and pilot holes.
4. Raise the downfeed handle, then turn the machine **OFF** and DISCONNECT BORING MACHINE FROM POWER!

Note: Do not unclamp the board yet—it must remain in this position to correctly adjust the swing arm.

5. Place the hinge into the cup to verify fit, make sure the mounting holes line up, and check that the mounting screws thread into the board.

—If the hinge fits correctly, proceed to **Adjusting Swing Arm Ram**.

—If the hinge does not fit correctly, disconnect power, unclamp the board, and readjust the head components as necessary. Then retest using a different place on the board or on a different board until the hinge does fit.

Swing Arm Test Fit & Adjustment

1. DISCONNECT BORING MACHINE FROM POWER!
2. Place the hinge onto the swing arm post, as shown in **Figure 41**.

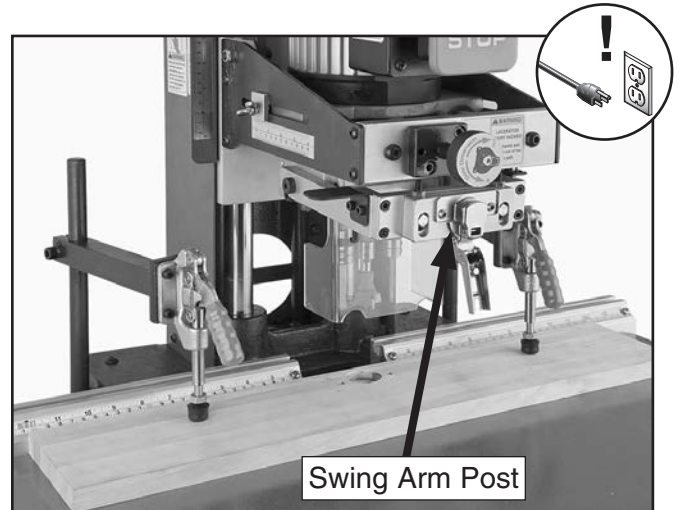

Figure 41. Hinge mounted to swing arm post.

3. Lower the swing arm so the hinge is directly above the cup hole, as shown in **Figure 42**.

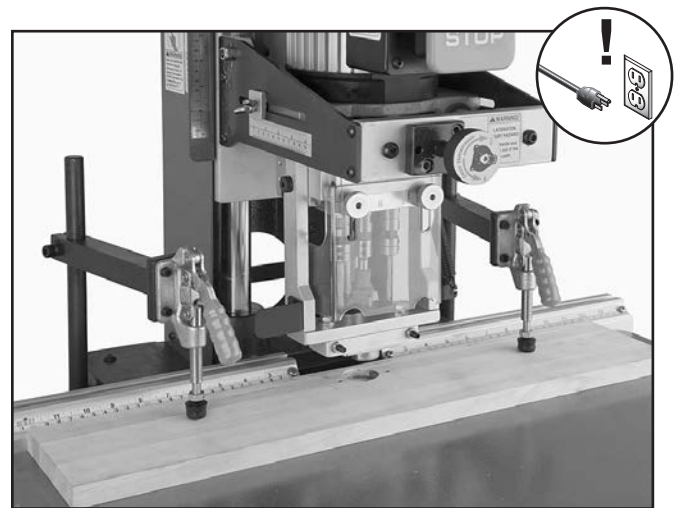

Figure 42. Swing arm positioned over cup hole.



- Loosen the two hex nuts on the swing arm assembly and the two hex nuts on the swing arm block, then loosen the set screws on the block several turns (see **Figure 43**).

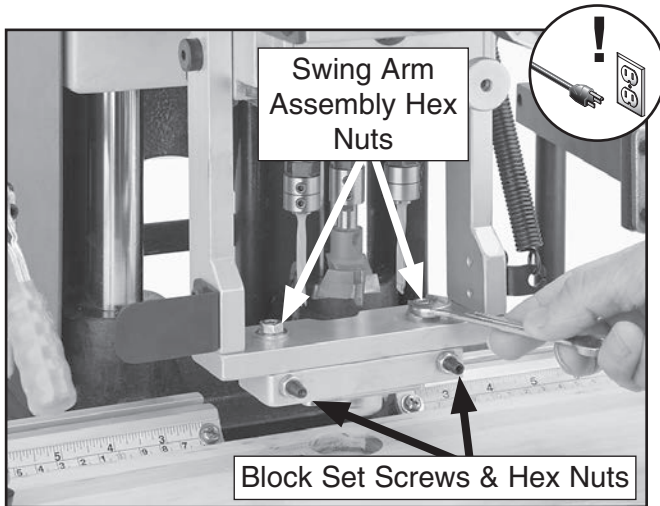

Figure 43. Loosening swing arm adjustment hex nuts.

- Adjust the swing arm block by hand as necessary to insert the hinge into the cup hole.
 - If you cannot insert the hinge into the hole, loosen the hex nuts and set screws several more turns, then try inserting the hinge again.
- Adjust the set screws to align the hinge mounting holes with the pilot holes.
- Secure the four hex nuts on the swing arm.
- Raise the downfeed handle and the swing arm.

Fence Stop Setup

The Model G0718 can bore holes for 2-hinge, 3-hinge, or 4-hinge doors, using the included fence stops and fences. (The extension fence is typically only used for 3- and 4-hinge doors.)

The fence stops are set along the fence as repeatable index points to ensure that the hinges are installed in the same position on all doors being produced.

Determining Number of Hinges

The required number of hinges—two, three, or four—depends on the specific door height and weight.

The following illustration (see **Figure 44**) is a general guideline for choosing the number of hinges for various cabinet door sizes. These specifications are designed for $\frac{5}{8}$ "– $\frac{3}{4}$ " thick cabinet doors. Refer to your hinge manufacturer's instructions for detailed height and weight specifications.

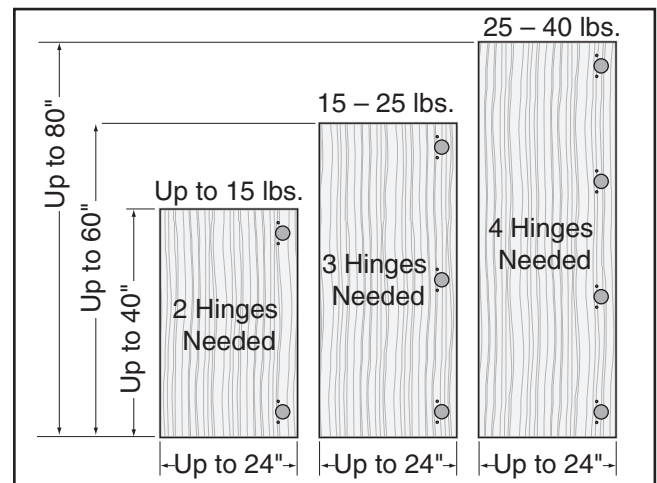

Figure 44. Determining number of hinges based on door height and weight.

Continued on next page →



Two-Hinge Door

Figure 45 demonstrates the sequential process of boring holes for a two-hinge door.

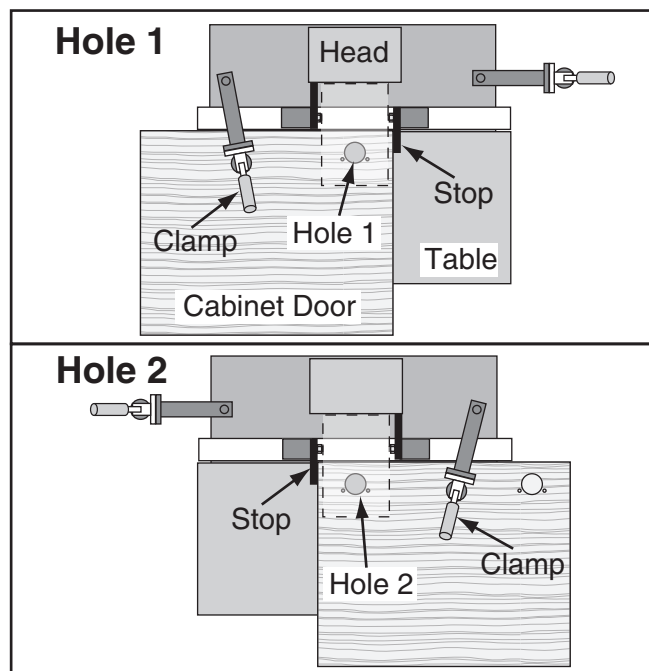

Figure 45. Example of two-hinge boring process.

Three-Hinge Door

Figure 46 demonstrates the sequential process of boring holes for a three-hinge door.

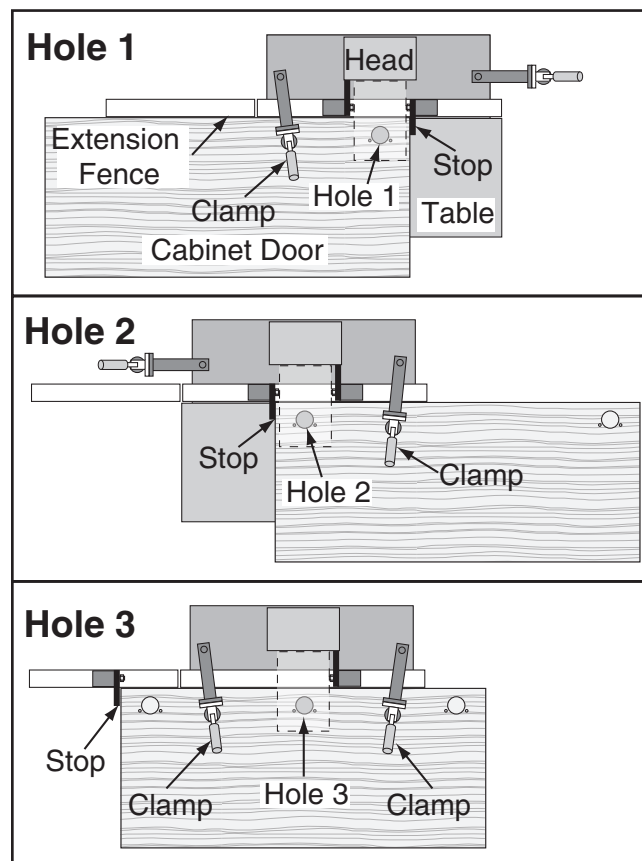

Figure 46. Example of three-hinge boring process.

Note: For large production runs, we recommend purchasing an optional fence stop (see Part 106A in **Accessories** on **Page 32**). If you plan to process a large number of cabinet doors, having three fence stops in preset positions will quicken the production process.



Four-Hinge Door

Figure 47 demonstrates the sequential process of boring holes for a four-hinge door.

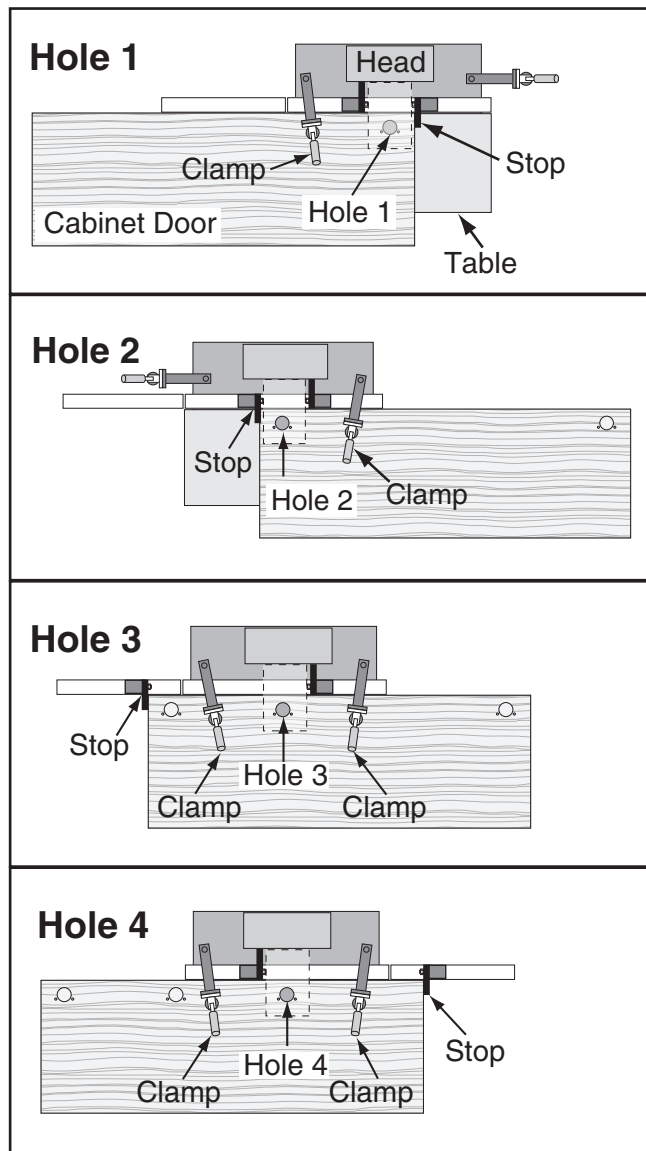

Figure 47. Example of four-hinge boring process.

The Model G0718 can bore four hinge cup holes in a cabinet door up to 63½" long using the standard extension fence and two included flip stops.

Note: For large production runs, we recommend purchasing two additional flip stops and an additional fence extension (see Part 106A and 143A in **Accessories** on **Page 32**). Having four fence stops and an added fence extension will allow you to speed up production and process cabinet doors up to 120" long.



SECTION 5: ACCESSORIES

!WARNING

Installing unapproved accessories may cause machine to malfunction, resulting in serious personal injury or machine damage. To reduce this risk, only install accessories recommended for this machine by Grizzly.

NOTICE

Refer to our website or latest catalog for additional recommended accessories.

Adjustable Boring Bits (1 Pc. Each)

T23666—3mm Pilot Bit

T23667—8mm Pilot Bit

T23668—10mm Pilot Bit

T23669—35mm Cup Bit

Bit Sets

T23670— 3mm (2), 35mm (1)

T23671—8mm (2), 35mm (1)

T23672—10mm (2), 35mm (1)

Boring Heads

Note: Boring bit heads do not include boring bits.

T23280—45mm—9.5mm Head

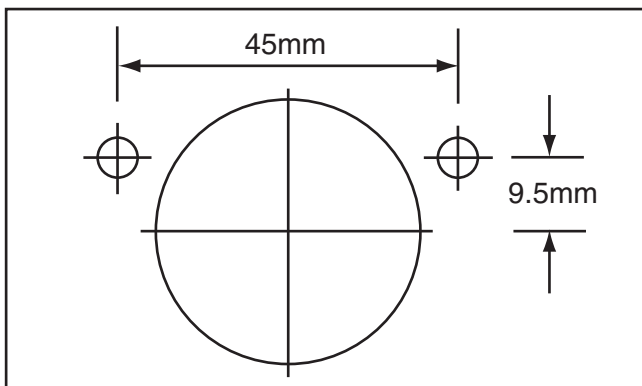

Figure 48. T23280 Boring Pattern Dimensions.

T23281—48mm—6mm Head

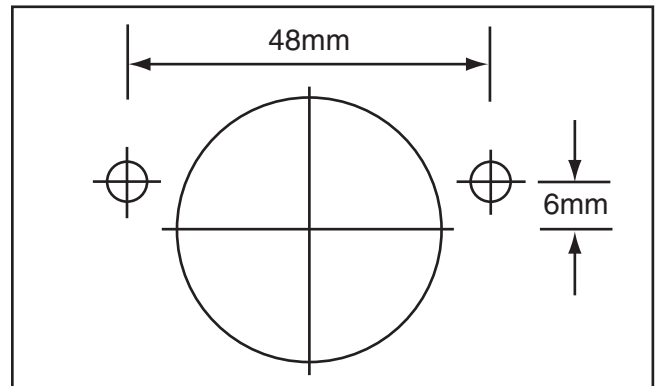

Figure 49. T23281 Boring Pattern Dimensions.

T23282—52mm—5.5mm Head

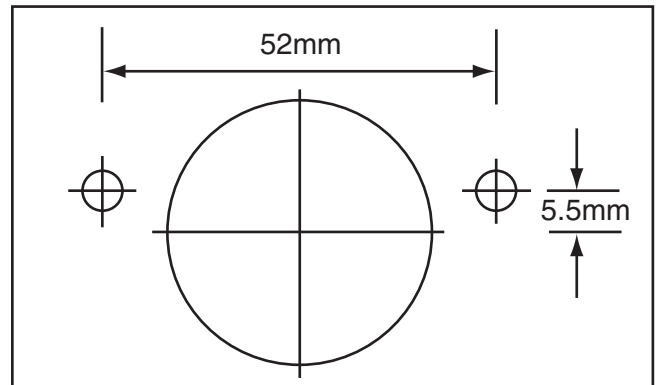

Figure 50. T23282 Boring Pattern Dimensions.



Figure 51. T23282 Boring Head.

order online at www.grizzly.com or call 1-800-523-4777



Part 106A—Extra Fence Stop

It's handy to have some extra fence stops for boring multiple holes in cabinets. That way, you won't have to keep moving the included stops with 3- or 4-hinge doors, especially for larger cabinet doors. Preset the location of three or four fence stops, then quickly and efficiently bore holes.

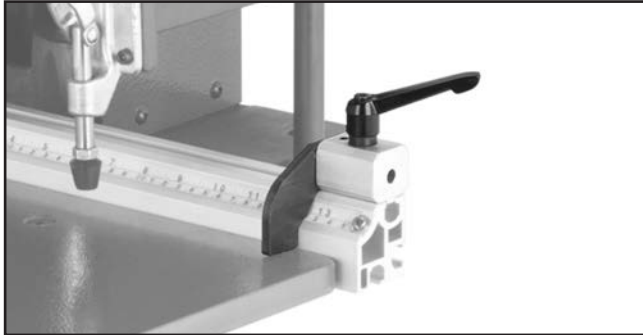

Figure 52. Part 106A Fence Stop.

Part 143A—Extra Fence Extension

Installing an additional fence extension eliminates the need to swap the included fence extension between the right and left sides of your Model G0718. It also allows you to set fence stops for longer doors and provides additional support.

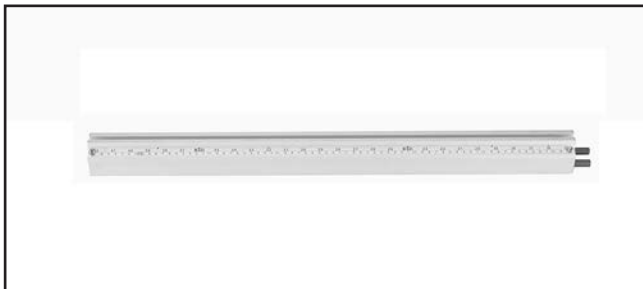

Figure 53. Part 143 Fence Extension.

T23950—Line Boring Head

Converts the Model G0718 to a 15 spindle line boring machine.

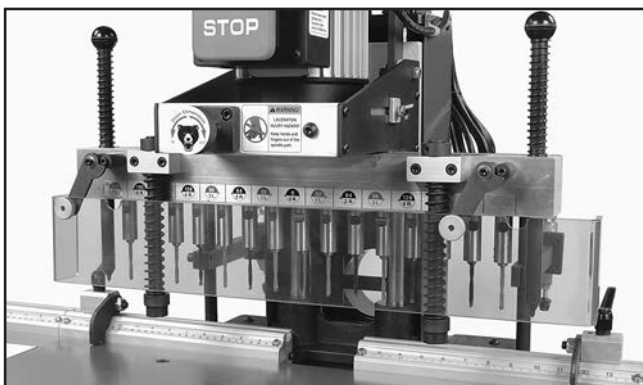

Figure 54. Model T23950 Line Boring Head.

W1038—4" Quick Disconnect Fitting.



Figure 55. W1038 Quick Disconnect Fitting.

D4206—Clear Flexible Hose 4" x 10'

D4256—45° Elbow 4"

D4216—Black Flexible Hose 4" x 10'

W1034—Heavy-Duty Clear Flex Hose 4" x 10'

D2107—Hose Hanger 4¼"

W1015—Y-Fitting 4" x 4" x 4"

W1017—90° Elbow 4"

W1019—Hose Coupler (Splice) 4"

W1317—Wire Hose Clamp 4"

W1007—Plastic Blast Gate 4"

W1053—Anti-Static Grounding Kit

We've hand picked a selection of commonly used dust collection components for machines with 4" dust ports.



Figure 56. Dust collection accessories.

order online at www.grizzly.com or call 1-800-523-4777



- G1163P—1HP Floor Model Dust Collector
- G0710—1HP Wall-Mount Dust Collector
- G3591—30 Micron Replacement Bag
- H4340—3.0 Micron Upgrade Bag

Excellent point-of-use dust collectors that can be used next to the machine with only a small amount of ducting. Specifications: 450 CFM, 7.2" static pressure, 2 cubic foot bag, and 30 micron filter. Motor is 1HP, 120V/240V, 7A/3.5A.

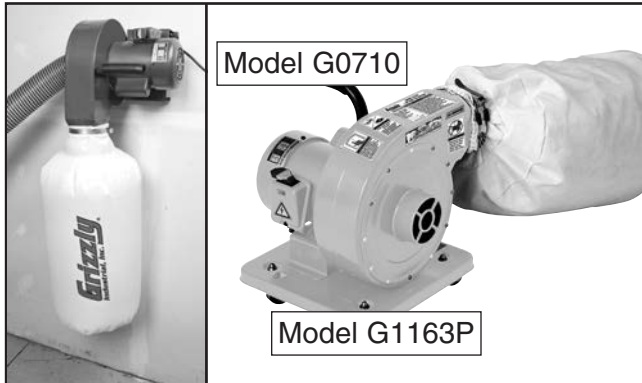

Figure 57. Point-of-use dust collectors.

- G5562—SLIPIT® 1 Qt. Gel
- G5563—SLIPIT® 12 oz. Spray
- G2871—Boeshield® T-9 12 oz. Spray
- G2870—Boeshield® T-9 4 oz. Spray
- H3788—G96® Gun Treatment 12 oz. Spray
- H3789—G96® Gun Treatment 4.5 oz. Spray



Figure 58. Recommended products for protecting unpainted cast iron/steel part on machinery.

Basic Eye Protection

- T20501—Face Shield Crown Protector 4"
- T20502—Face Shield Crown Protector 7"
- T20503—Face Shield Window
- T20451—"Kirova" Clear Safety Glasses
- T20452—"Kirova" Anti-Reflective S. Glasses
- T20456—DAKURA Safety Glasses, Black/Clear



Figure 59. Assortment of basic eye protection.

- H2499—Small Half-Mask Respirator
- H3631—Medium Half-Mask Respirator
- H3632—Large Half-Mask Respirator
- H3635—Cartridge Filter Pair P100

Wood dust has been linked to nasal cancer and severe respiratory illnesses. If you work around-dust everyday, a half-mask respirator can be a lifesaver. Also compatible with safety glasses!

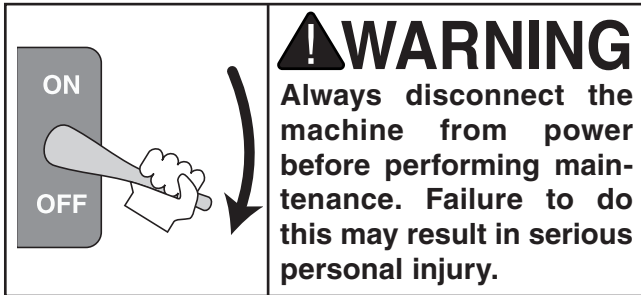

Figure 60. Half-mask respirator with disposable cartridge filters.

order online at www.grizzly.com or call 1-800-523-4777



SECTION 6: MAINTENANCE



Schedule

For optimum performance from this machine, this maintenance schedule must be strictly followed.

Ongoing

To maintain a low risk of injury and proper machine operation, if you ever observe any of the items below, shut down the machine immediately and fix the problem before continuing operations:

- Clean table, boring head assembly, and motor of sawdust and resin.
- Check for loose mounting bolts.
- Check for worn or damaged boring bits.
- Check for worn or damaged wires.
- Check for any other unsafe condition.

Monthly Maintenance:

- Lubricate boring head assembly.
- Lubricate pivot points.
- Clean and lubricate adjustment shafts.

Cleaning

Cleaning the Model G0718 is relatively easy. Vacuum excess wood chips and sawdust, and wipe off the remaining dust with a dry cloth. If any resin has built up, use a resin dissolving cleaner to remove it. Treat all unpainted steel with a non-staining lubricant after cleaning.

Lubrication

It is essential to clean components before lubricating them because dust and chips build up on lubricated components and make them hard to move. Simply adding more lubricant to them will not yield smooth moving components.

Clean the components in this section with mineral spirits, a rag, or a bristle brush as directed.

The following are the main components that need to be lubricated:

- Headstock slides
- Depth and throat adjustment shafts.
- Pivot points
- Boring head assembly

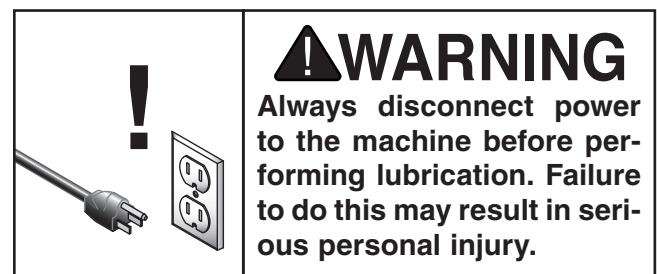

Headstock Slides

Perform monthly. Clean sawdust and debris from the visible sections of the vertical and horizontal slides (see **Figures 61–62**) with mineral spirits and a rag. Apply a thin coat of light machine oil to the slides. Use the downfeed handle to move the boring head assembly through the entire range of motion to evenly distribute the oil.

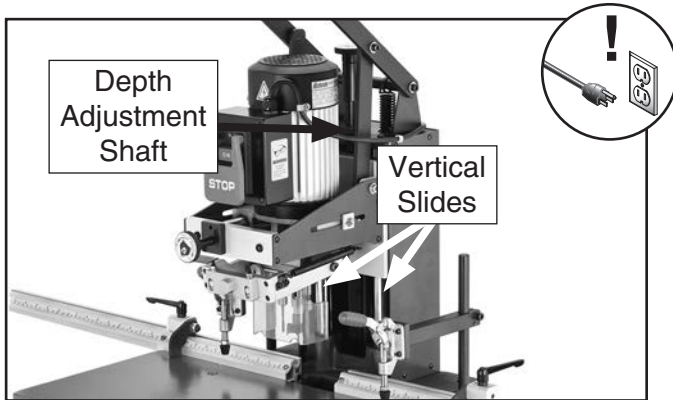

Figure 61. Vertical slides and depth shaft.

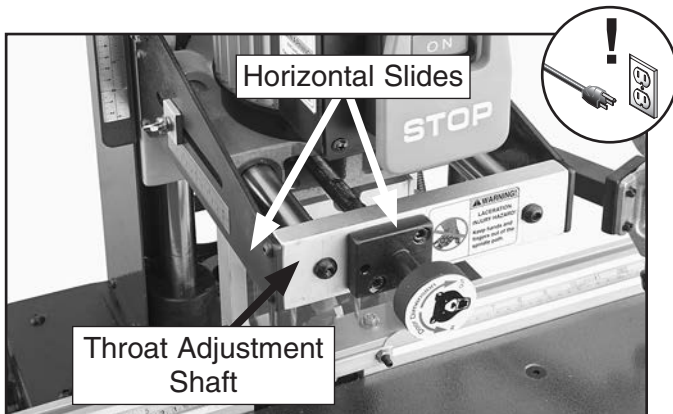

Figure 62. Horizontal slides and throat shaft.

Depth & Throat Adjustment Shafts

Perform monthly. Use a stiff bristle brush and mineral spirits to clean grime and debris from the visible sections of the depth and throat adjustment shafts (see **Figures 61–62**). Apply a thin coat of light machine oil to the shafts. Turn the adjustment knobs to move the shafts through the entire range of motion to evenly distribute the oil.

Pivot Points

Perform monthly. Apply a few drops of light machine oil to each of the pivot points shown in **Figure 63**.

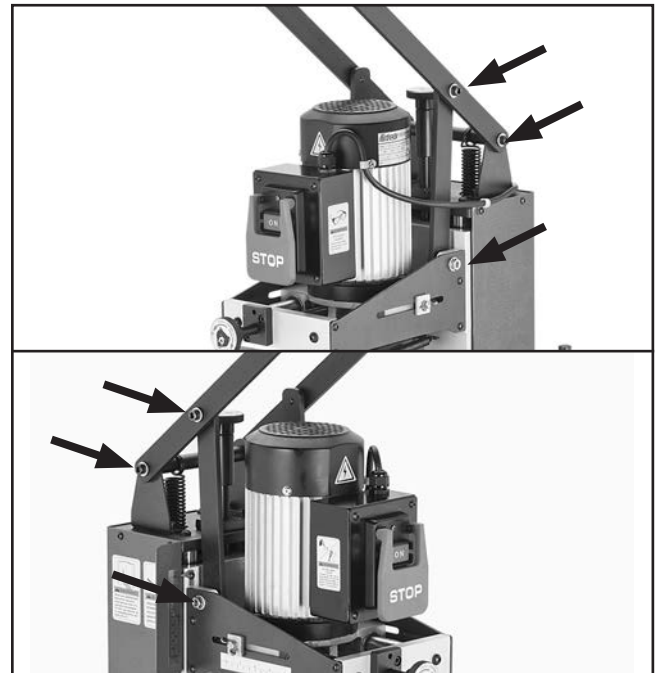

Figure 63. Location of pivot points.

Boring Head Assembly

Use a grease gun to inject several pumps of Mobilith SHC460 grease (or equivalent) into the grease fitting (see **Figure 64**), 2–3 times every 40 hours. Since the boring head is pre-packed with grease at the factory, it is not necessary to pump large amounts of grease into it.

Note: We do NOT recommend repacking the boring head with grease during its operational life. Re-assembly is difficult and may reduce later accuracy or functionality of the moving parts.

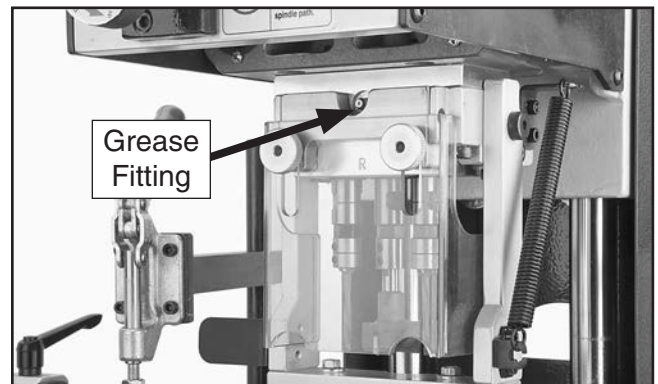

Figure 64. Grease fitting location.



SECTION 7: SERVICE

Review the troubleshooting procedures in this section if a problem develops with your machine. If you need replacement parts or additional help with a procedure, call our Technical Support. **Note:** *Please gather the serial number and manufacture date of your machine before calling.*

Troubleshooting

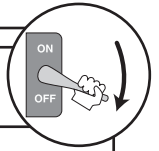

Motor & Electrical

Symptom	Possible Cause	Possible Solution
Machine does not start or a breaker trips.	<ol style="list-style-type: none"> 1. Plug/receptacle is at fault or wired incorrectly. 2. Start capacitor is at fault. 3. Motor connection wired incorrectly. 4. Wall fuse/circuit breaker is blown/tripped. 5. Power supply switched OFF or is at fault. 6. Wiring is open/has high resistance. 7. Power ON/OFF switch is at fault. 8. Centrifugal switch is at fault. 9. Motor is at fault. 	<ol style="list-style-type: none"> 1. Test for good contacts; correct the wiring. 2. Test/replace if faulty. 3. Correct motor wiring connections. 4. Ensure circuit size is suitable for this machine; replace weak breaker. 5. Ensure power supply is switched on; ensure power supply has the correct voltage. 6. Check for broken wires or disconnected/corroded connections, and repair/replace as necessary. 7. Replace faulty ON/OFF switch. 8. Adjust/replace the centrifugal switch if available. 9. Test/repair/replace.
Machine has vibration or noisy operation.	<ol style="list-style-type: none"> 1. Boring bit is at fault. 2. Motor or component is loose. 3. Motor fan is rubbing on fan cover. 4. Machine is incorrectly mounted or sits unevenly on workbench or stand. 5. Motor mount loose/broken. 6. Motor or boring head bearings are at fault. 7. Centrifugal switch is at fault. 	<ol style="list-style-type: none"> 1. Replace dull or bent boring bit. 2. Inspect/replace stripped or damaged bolts/nuts, and re-tighten with thread locking fluid. 3. Replace dented fan cover; replace loose/damaged fan. 4. Tighten/replace fasteners; relocate/shim machine. 5. Tighten/replace. 6. Replace bearings. 7. Replace centrifugal switch.
Machine slows or stalls.	<ol style="list-style-type: none"> 1. Workpiece material is not suitable for this machine, or machine undersized for the task. 2. Run capacitor is at fault. 3. Motor connection is wired incorrectly. 4. Plug/receptacle is at fault. 5. Motor or boring head bearings are at fault. 6. Centrifugal switch is at fault. 7. Motor has overheated. 8. Motor is at fault. 	<ol style="list-style-type: none"> 1. Only drill wood products; make sure moisture content is below 20% and use sharp bits/reduce downfeed rate. 2. Test/repair/replace. 3. Correct motor wiring connections. 4. Test for good contacts; correct the wiring. 5. Replace bearings. 6. Adjust/replace centrifugal switch. 7. Clean off motor, let cool, and reduce workload. 8. Test/repair/replace.



Operation

Symptom	Possible Cause	Possible Solution
Holes bored at an angle, or out of round.	1. Chuck or boring bit is at fault.	1. Replace out-of-round chuck; replace/re-install boring bit.
Cup hole or pilot hole depth too deep or too shallow.	1. Boring bit depth incorrect.	1. Turn adjusting set screw on bit(s) in needed direction to attain the correct depth.
Cup hole is drilled too far away or too close to the edge of workpiece.	1. Lateral position of boring bits is incorrect. Cup bit tip not positioned over center line.	1. Adjust the setback (see Page 26). Check to make sure tip of cup bit is directly over center line.
Hinge mounting holes do not align with pilot holes drilled into workpiece.	1. Swing arm block is incorrectly positioned. 2. Style of hinge does not match boring head.	1. Adjust the swing arm block (see Page 29). 2. Install hinges that match the boring head pattern.
Hinge will not insert into cup hole.	1. Hinge cup hole drilled too shallow.	1. Adjust set screw on cup bit out so it drills deeper.
Workpiece moves when secured with hold-downs.	1. Hold-down clamp feet are not tight enough against the workpiece.	1. Adjust hold-downs (see Page 23).

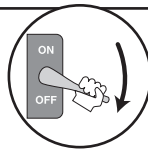

SECTION 8: WIRING

These pages are current at the time of printing. However, in the spirit of improvement, we may make changes to the electrical systems of future machines. Compare the manufacture date of your machine to the one stated in this manual, and study this section carefully.

If there are differences between your machine and what is shown in this section, call Technical Support at (570) 546-9663 for assistance BEFORE making any changes to the wiring on your machine. An updated wiring diagram may be available. **Note:** *Please gather the serial number and manufacture date of your machine before calling. This information can be found on the main machine label.*

WARNING

Wiring Safety Instructions

SHOCK HAZARD. Working on wiring that is connected to a power source is extremely dangerous. Touching electrified parts will result in personal injury including but not limited to severe burns, electrocution, or death. Disconnect the power from the machine before servicing electrical components!

MODIFICATIONS. Modifying the wiring beyond what is shown in the diagram may lead to unpredictable results, including serious injury or fire. This includes the installation of unapproved after-market parts.

WIRE CONNECTIONS. All connections must be tight to prevent wires from loosening during machine operation. Double-check all wires disconnected or connected during any wiring task to ensure tight connections.

CIRCUIT REQUIREMENTS. You MUST follow the requirements at the beginning of this manual when connecting your machine to a power source.

WIRE/COMPONENT DAMAGE. Damaged wires or components increase the risk of serious personal injury, fire, or machine damage. If you notice that any wires or components are damaged while performing a wiring task, replace those wires or components.

MOTOR WIRING. The motor wiring shown in these diagrams is current at the time of printing but may not match your machine. If you find this to be the case, use the wiring diagram inside the motor junction box.















CAPACITORS/INVERTERS. Some capacitors and power inverters store an electrical charge for up to 10 minutes after being disconnected from the power source. To reduce the risk of being shocked, wait at least this long before working on capacitors.

EXPERIENCING DIFFICULTIES. If you are experiencing difficulties understanding the information included in this section, contact our Technical Support at (570) 546-9663.

NOTICE

The photos and diagrams included in this section are best viewed in color. You can view these pages in color at www.grizzly.com.

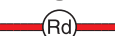
COLOR KEY

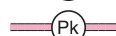
BLACK		BLUE		YELLOW		LIGHT BLUE	
WHITE		BROWN		YELLOW GREEN		BLUE WHITE	
GREEN		GRAY		PURPLE		TURQUOISE	
RED		ORANGE		PINK			



Wiring Diagram

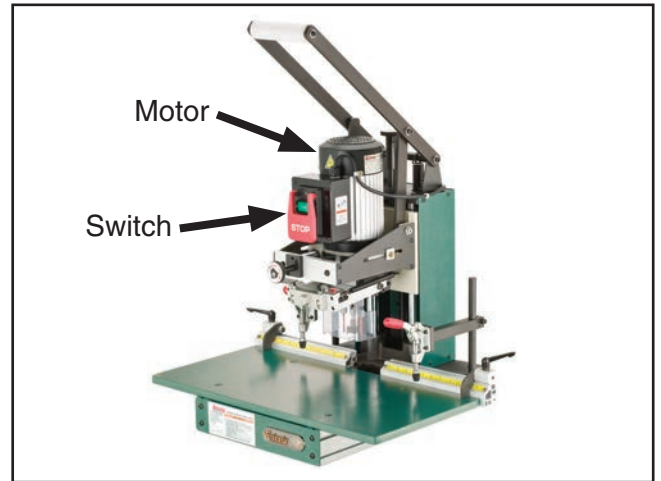
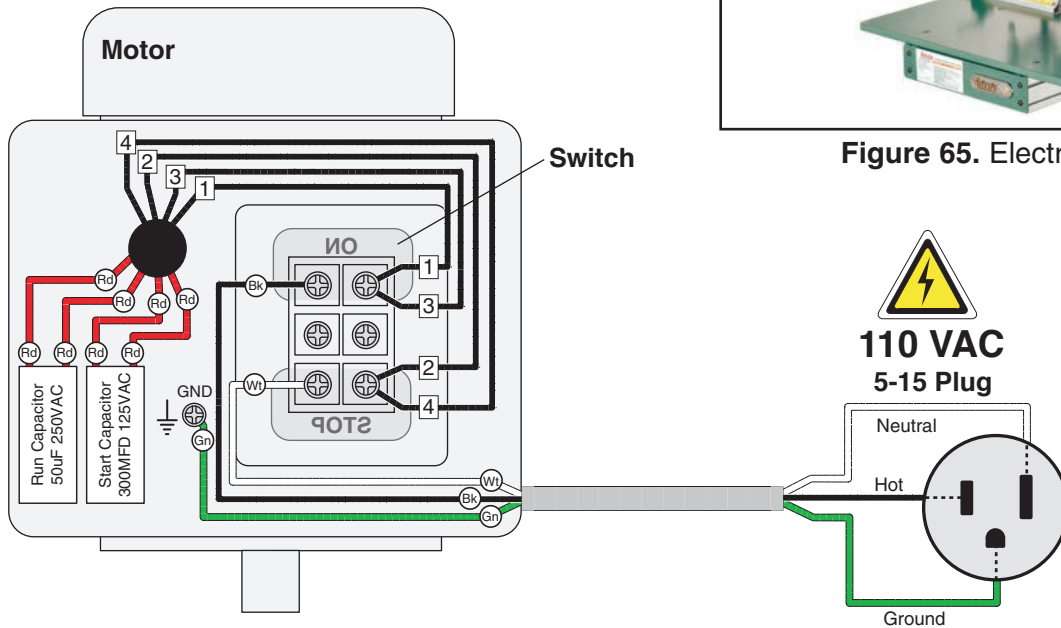
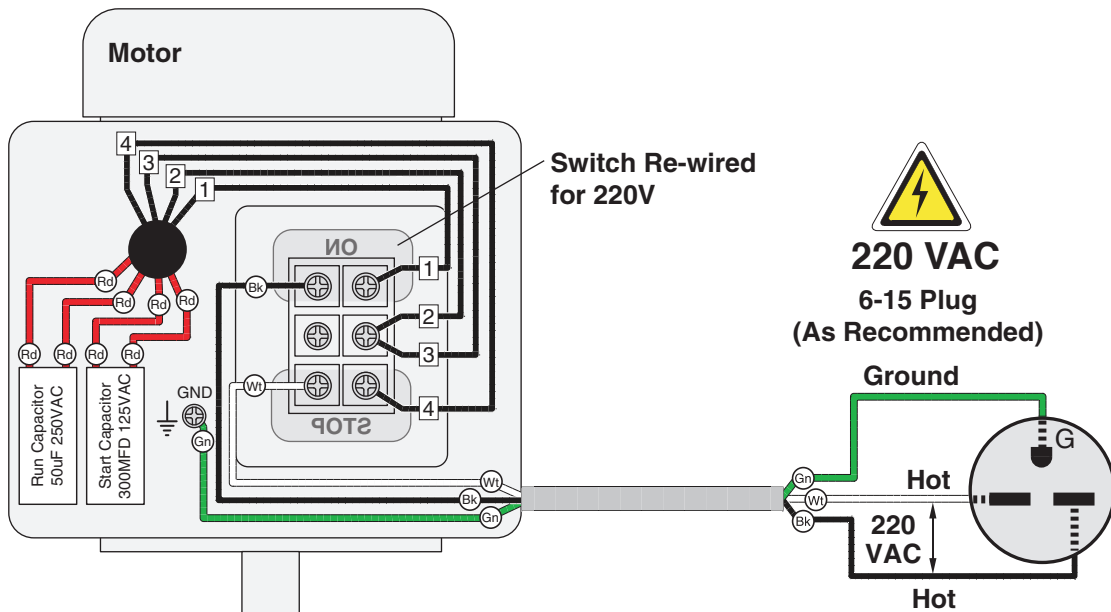

Figure 65. Electrical overview.

110V Wiring



Machine Re-wired for 220V



SECTION 9: PARTS

Body

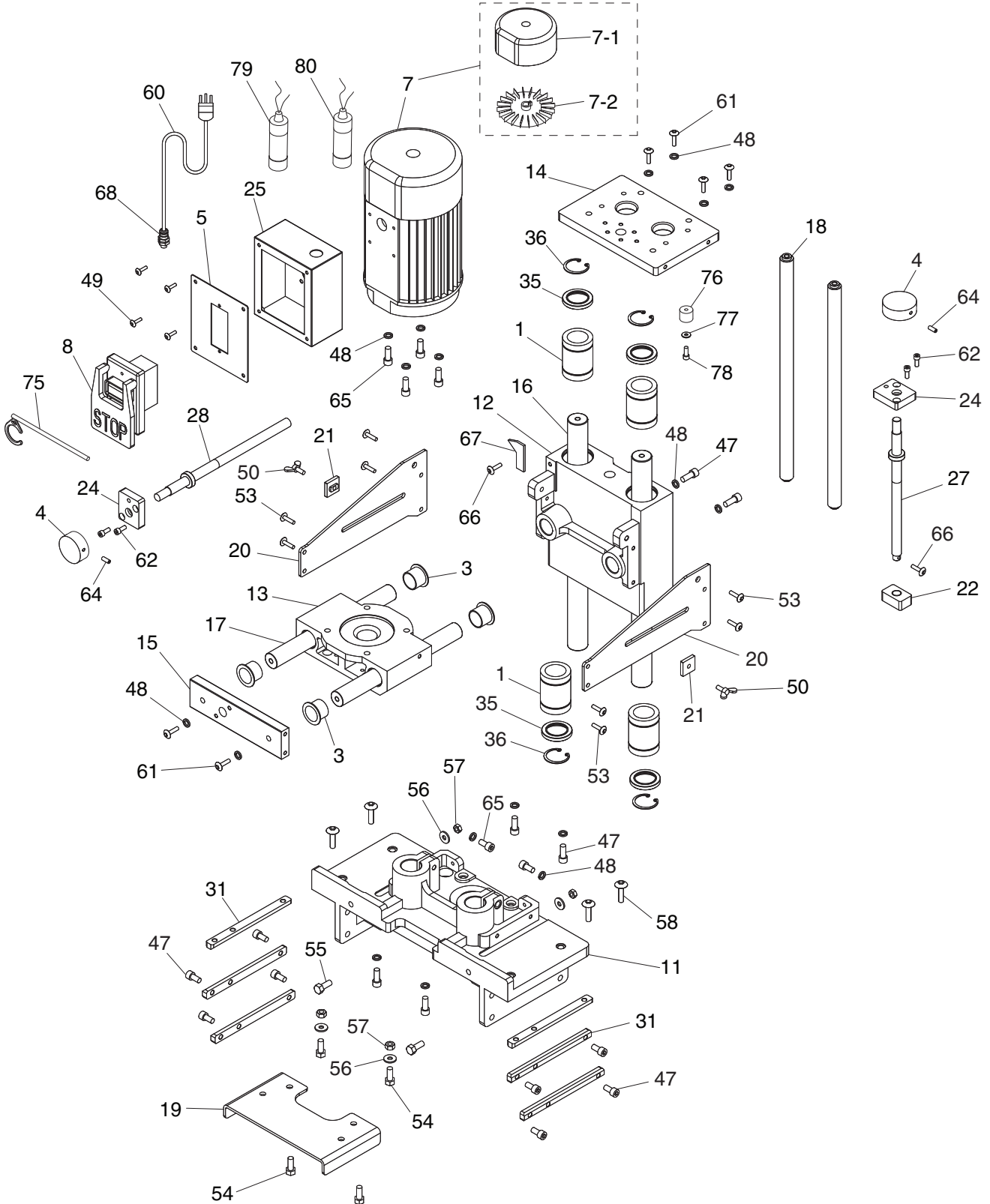

Body Parts List

REF	PART #	DESCRIPTION
1	P0718001	VERTICAL ROUND ROD BUSHING
3	P0718003	ROUND ROD DRYMET BEARING
4	P0718004	KNURLED KNOB
5	P0718005	SWITCH BOX COVER
7	P0718007	MOTOR 1HP 110/220V 1PH
7-1	P0718007-1	MOTOR FAN COVER
7-2	P0718007-2	MOTOR FAN
8	P0718008	ON/OFF PADDLE SWITCH ASSEMBLY
11	P0718011	COLUMN BASE
12	P0718012	COLUMN
13	P0718013	MOTOR MOUNT
14	P0718014	UPPER COLUMN COVER
15	P0718015	ROD CONNECTION BAR
16	P0718016	VERTICAL ROUND ROD
17	P0718017	HORIZONTAL ROUND ROD
18	P0718018	COLUMN ROD
19	P0718019	TABLE BASE
20	P0718020	MOTOR MOUNT SIDE BRACKET
21	P0718021	THREADED PLATE
22	P0718022	THREADED BLOCK
24	P0718024	DEPTH CONTROL GAUGE MOUNT
25	P0718025	SWITCH BOX
27	P0718027	VERTICAL CONTROL ROD
28	P0718028	HORIZONTAL CONTROL ROD
31	P0718031	BASE CONNECTION BAR
35	P0718035	BUSHING SEAL

REF	PART #	DESCRIPTION
36	P0718036	INT RETAINING RING 45MM
47	P0718047	CAP SCREW M8-1.25 X 20
48	P0718048	LOCK WASHER 8MM
49	P0718049	FLANGE BOLT M5-.8 X 12
50	P0718050	WING SCREW M6-1 X 16
53	P0718053	BUTTON HD CAP SCR M6-1 X 20
54	P0718054	HEX BOLT M8-1.25 X 16
55	P0718055	HEX BOLT M8-1.25 X 25
56	P0718056	FLAT WASHER 8MM
57	P0718057	HEX NUT M8-1.25
58	P0718058	BUTTON HD CAP SCR M8-1.25 X 30
60	P0718060	POWER CORD 14G 3C 5FT 5-15 PLUG
61	P0718061	BUTTON HD CAP SCR M8-1.25 X 20
62	P0718062	CAP SCREW M6-1 X 12
64	P0718064	SET SCREW M6-1 X 10
65	P0718065	CAP SCREW M8-1.25 X 30
66	P0718066	BUTTON HD CAP SCR M5-.8 X 12
67	P0718067	POINTER
68	P0718068	STRAIN RELIEF
75	P0718075	SWITCH DISABLING PIN
76	P0718076	BUFFER PAD
77	P0718077	FLAT WASHER 6MM
78	P0718078	CAP SCREW M6-1 X 20
79	P0718079	S CAPACITOR 300M 125V 1-3/8 X 2-5/8
80	P0718080	R CAPACITOR 50M 250V 1-5/8 X 2-3/8

Please Note: We do our best to stock replacement parts whenever possible, but we cannot guarantee that all parts shown here are available for purchase. Call (800) 523-4777 or visit our online parts store at www.grizzly.com to check for availability.



Table

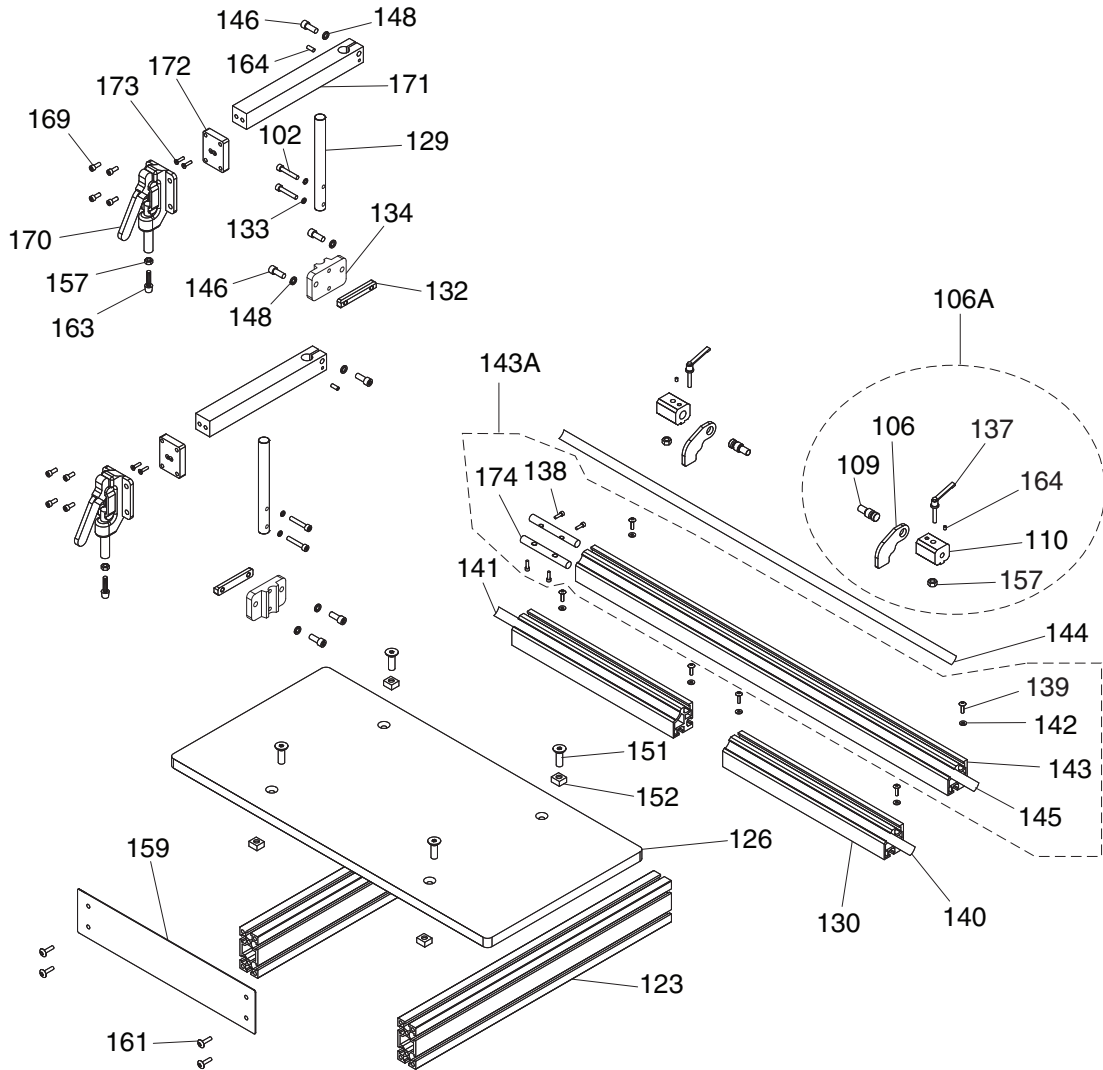

REF	PART #	DESCRIPTION
102	P0718102	CAP SCREW M6-1 X 30
106	P0718106	LONGITUDINAL STOP PLATE
106A	P0718106A	LONGITUDINAL STOP ASSEMBLY
109	P0718109	STOP PIN
110	P0718110	STOP PLATE BASE
123	P0718123	BASE RAILS
126	P0718126	TABLE
129	P0718129	CLAMP ROD
130	P0718130	FRONT LONGITUDINAL FENCE
132	P0718132	CLAMP CONNECTION BAR
133	P0718133	LOCK WASHER 6MM
134	P0718134	CLAMP BASE
137	P0718137	LOCK LEVER
138	P0718138	CAP SCREW M5-.8 X 16
139	P0718139	PHLP HD SCR M5-.8 X 12
140	P0718140	RIGHT FRONT LONGITUDINAL SCALE
141	P0718141	LEFT FRONT LONGITUDINAL SCALE
142	P0718142	FLAT WASHER 5MM
143	P0718143	REAR LONGITUDINAL FENCE

REF	PART #	DESCRIPTION
143A	P0718143A	REAR LONGITUDINAL FENCE ASSY
144	P0718144	LEFT REAR LONGITUDINAL SCALE
145	P0718145	RIGHT REAR LONGITUDINAL SCALE
146	P0718146	CAP SCREW M8-1.25 X 25
148	P0718148	LOCK WASHER 8MM
151	P0718151	FLAT HD SCR M8-1.25 X 30
152	P0718152	T-NUT M8-1.25
157	P0718157	HEX NUT M8-1.25
159	P0718159	BASE FRONT COVER
161	P0718161	BUTTON HD CAP SCR M8-1.25 X 20
163	P0718163	HOLD-DOWN BOLT NEOPRENE TIP
164	P0718164	SET SCREW M6-1 X 10
169	P0718169	CAP SCREW M5-.8 X 16
170	P0718170	CLAMP ASSEMBLY
171	P0718171	CLAMP HORIZONTAL SUPPORT
172	P0718172	CLAMP PAD
173	P0718173	FLAT HD SCR M6-1 X 16
174	P0718174	FENCE CONNECTING ROD



Headstock

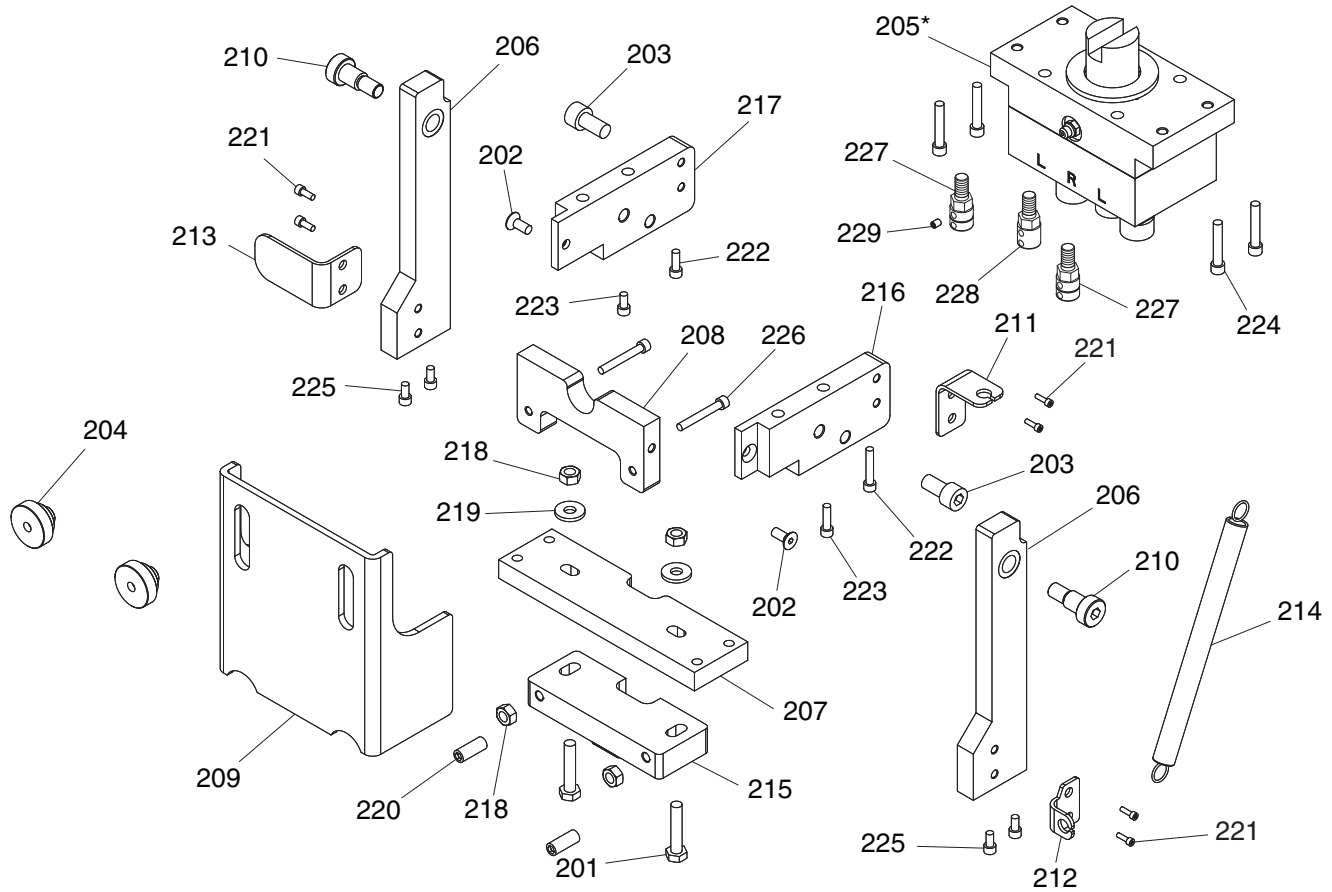

REF	PART #	DESCRIPTION
201	P0718201	HEX BOLT M6-1 X 30
202	P0718202	FLAT HD SCR M5-.8 X 12
203	P0718203	CAP SCREW M8-1.25 X 12
204	P0718204	KNURLED KNOB
205*	P0718205	BORING HEAD 45 X 9.5MM
205*	P0718205	BORING HEAD 48 X 6MM
205*	P0718205	BORING HEAD 52 X 5.5MM
206	P0718206	PIVOT ARM
207	P0718207	PIVOT ARM FRONT BRACE
208	P0718208	GUARD BRACKET
209	P0718209	BORING HEAD GUARD
210	P0718210	PIVOT ARM STEP BOLT
211	P0718211	UPPER SPRING BRACKET
212	P0718212	LOWER SPRING BRACKET
213	P0718213	L-BRACKET
214	P0718214	PIVOT ARM EXTENSION SPRING

REF	PART #	DESCRIPTION
215	P0718215	STOP BRACKET
216	P0718216	BORING HEAD RIGHT SUPPORT
217	P0718217	BORING HEAD LEFT SUPPORT
218	P0718218	HEX NUT M6-1
219	P0718219	FLAT WASHER 6MM
220	P0718220	SET SCREW M6-1 X 30
221	P0718221	CAP SCREW M5-.8 X 12
222	P0718222	CAP SCREW M6-1 X 55
223	P0718223	CAP SCREW M6-1 X 45
224	P0718224	CAP SCREW M6-1 X 65
225	P0718225	CAP SCREW M5-.8 X 16
226	P0718226	CAP SCREW M6-1 X 25
227	P0718227	LEFT BIT ARBOR
228	P0718228	RIGHT BIT ARBOR
229	P0718229	SET SCREW M5-.8 X 5

* Optional Equipment Purchased Separately



Handle

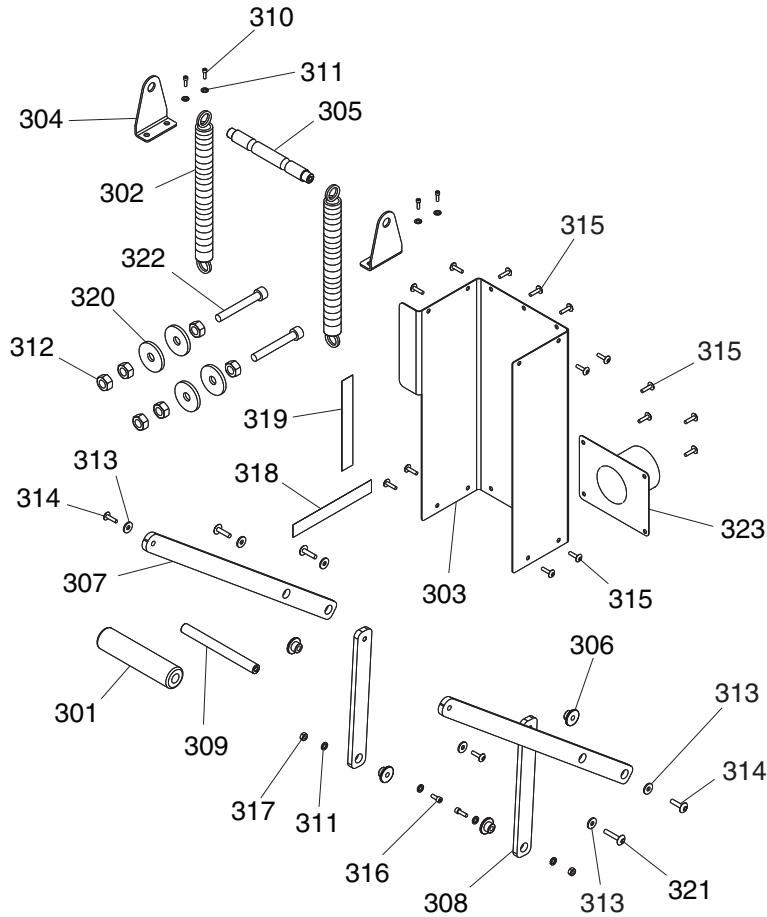

REF	PART #	DESCRIPTION
301	P0718301	HANDLE
302	P0718302	HEADSTOCK EXTENSION SPRING
303	P0718303	COLUMN COVER
304	P0718304	HEADSTOCK SPRING BRACKET
305	P0718305	UPPER SPRING ROD
306	P0718306	PIVOT CONNECTOR
307	P0718307	HANDLE PIVOT BAR
308	P0718308	VERTICAL PIVOT BAR
309	P0718309	LOWER SPRING ROD
310	P0718310	CAP SCREW M8-1.25 X 16
311	P0718311	LOCK WASHER 8MM
312	P0718312	HEX NUT M8-1.25

REF	PART #	DESCRIPTION
313	P0718313	FLAT WASHER 8MM
314	P0718314	BUTTON HD CAP SCR M8-1.25 X 20
315	P0718315	BUTTON HD CAP SCR M6-1 X 12
316	P0718316	CAP SCREW M8-1.25 X 40
317	P0718317	LOCK NUT M10-1.5
318	P0718318	HORIZONTAL SCALE 0-10MM
319	P0718319	VERTICAL SCALE 10-0MM
320	P0718320	FENDER WASHER 8MM
321	P0718321	BUTTON HD CAP SCR M8-1.25 X 25
322	P0718322	CAP SCREW M8-1.25 X 50
323	P0718323	DUST PORT 4"



Machine Labels

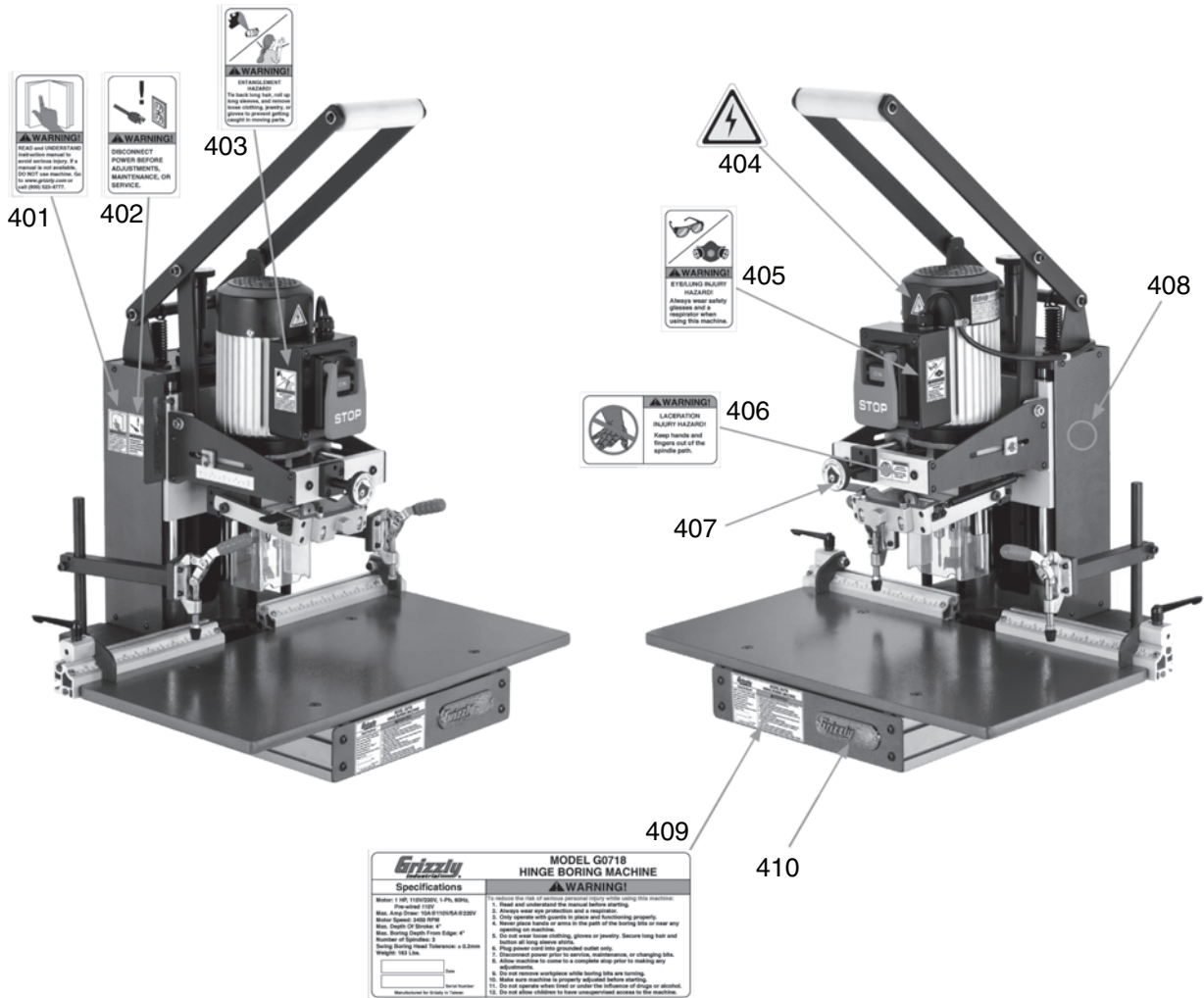

Grizzly		MODEL G0718 HINGE BORING MACHINE	
Specifications		WARNING!	
Model 1 HP, 115V/208V, 1 Ph, 50/60 Hz, Fractional HP		1. Read and understand the manual before starting.	
Max. Amp Draw: 10A @ 115V/208V/240V		2. Always wear eye protection and a respirator.	
Motor Speed: 1500 RPM		3. Only operate with guards in place and locking pins properly.	
Max. Depth Of Stroke: 4"		4. Do not wear loose clothing, gloves or jewelry. Secure long hair and button all long sleeve shirts.	
Max. Boring Depth From Edge: 4"		5. Plug power cord into grounded outlet only.	
Number of Spindles: 1		6. Disconnect power prior to service, maintenance, or changing bits.	
Boring Speed Tolerance: ± 0.2mm		7. Allow machine to come to a complete stop prior to making any adjustments.	
Weight: 160 Lbs.		8. Do not remove workpiece while boring bit are turning.	
		9. Make sure machine is properly adjusted before starting.	
		10. Do not operate when ill or under the influence of drugs or alcohol.	
		11. Do not allow children to have unassisted access to the machine.	

REF	PART #	DESCRIPTION
401	P0718401	READ MANUAL LABEL
402	P0718402	DISCONNECT POWER LABEL
403	P0718403	ENTANGLEMENT HAZARD LABEL
404	P0718404	ELECTRICITY LABEL
405	P0718405	EYE/LUNG HAZARD LABEL

REF	PART #	DESCRIPTION
406	P0718406	LACERATION HAZARD LABEL
407	P0718407	DIMENSION LABEL
408	P0718408	GRIZZLY GREEN TOUCH-UP PAINT
409	P0718409	MACHINE ID LABEL
410	P0718410	GRIZZLY LOGO PLATE

WARNING

Safety labels help reduce the risk of serious injury caused by machine hazards. If any label comes off or becomes unreadable, the owner of this machine **MUST** replace it in the original location before resuming operations. For replacements, contact (800) 523-4777 or www.grizzly.com.





WARRANTY CARD

Name _____
 Street _____
 City _____ State _____ Zip _____
 Phone # _____ Email _____
 Model # _____ Order # _____ Serial # _____

The following information is given on a voluntary basis. It will be used for marketing purposes to help us develop better products and services. **Of course, all information is strictly confidential.**

- How did you learn about us?

<input type="checkbox"/> Advertisement	<input type="checkbox"/> Friend	<input type="checkbox"/> Catalog
<input type="checkbox"/> Card Deck	<input type="checkbox"/> Website	<input type="checkbox"/> Other:
- Which of the following magazines do you subscribe to?

<input type="checkbox"/> Cabinetmaker & FDM	<input type="checkbox"/> Popular Science	<input type="checkbox"/> Wooden Boat
<input type="checkbox"/> Family Handyman	<input type="checkbox"/> Popular Woodworking	<input type="checkbox"/> Woodshop News
<input type="checkbox"/> Hand Loader	<input type="checkbox"/> Precision Shooter	<input type="checkbox"/> Woodsmith
<input type="checkbox"/> Handy	<input type="checkbox"/> Projects in Metal	<input type="checkbox"/> Woodwork
<input type="checkbox"/> Home Shop Machinist	<input type="checkbox"/> RC Modeler	<input type="checkbox"/> Woodworker West
<input type="checkbox"/> Journal of Light Cont.	<input type="checkbox"/> Rifle	<input type="checkbox"/> Woodworker's Journal
<input type="checkbox"/> Live Steam	<input type="checkbox"/> Shop Notes	<input type="checkbox"/> Other:
<input type="checkbox"/> Model Airplane News	<input type="checkbox"/> Shotgun News	
<input type="checkbox"/> Old House Journal	<input type="checkbox"/> Today's Homeowner	
<input type="checkbox"/> Popular Mechanics	<input type="checkbox"/> Wood	
- What is your annual household income?

<input type="checkbox"/> \$20,000-\$29,000	<input type="checkbox"/> \$30,000-\$39,000	<input type="checkbox"/> \$40,000-\$49,000
<input type="checkbox"/> \$50,000-\$59,000	<input type="checkbox"/> \$60,000-\$69,000	<input type="checkbox"/> \$70,000+
- What is your age group?

<input type="checkbox"/> 20-29	<input type="checkbox"/> 30-39	<input type="checkbox"/> 40-49
<input type="checkbox"/> 50-59	<input type="checkbox"/> 60-69	<input type="checkbox"/> 70+
- How long have you been a woodworker/metalworker?

<input type="checkbox"/> 0-2 Years	<input type="checkbox"/> 2-8 Years	<input type="checkbox"/> 8-20 Years	<input type="checkbox"/> 20+ Years
------------------------------------	------------------------------------	-------------------------------------	------------------------------------
- How many of your machines or tools are Grizzly?

<input type="checkbox"/> 0-2	<input type="checkbox"/> 3-5	<input type="checkbox"/> 6-9	<input type="checkbox"/> 10+
------------------------------	------------------------------	------------------------------	------------------------------
- Do you think your machine represents a good value? Yes No
- Would you recommend Grizzly Industrial to a friend? Yes No
- Would you allow us to use your name as a reference for Grizzly customers in your area?
Note: We never use names more than 3 times. Yes No

10. Comments: _____

CUT ALONG DOTTED LINE

FOLD ALONG DOTTED LINE



Place
Stamp
Here



GRIZZLY INDUSTRIAL, INC.
P.O. BOX 2069
BELLINGHAM, WA 98227-2069



FOLD ALONG DOTTED LINE

Send a Grizzly Catalog to a friend:

Name _____
Street _____
City _____ State _____ Zip _____

TAPE ALONG EDGES--PLEASE DO NOT STAPLE

WARRANTY AND RETURNS

Grizzly Industrial, Inc. warrants every product it sells for a period of **1 year** to the original purchaser from the date of purchase. This warranty does not apply to defects due directly or indirectly to misuse, abuse, negligence, accidents, repairs or alterations or lack of maintenance. This is Grizzly's sole written warranty and any and all warranties that may be implied by law, including any merchantability or fitness, for any particular purpose, are hereby limited to the duration of this written warranty. We do not warrant or represent that the merchandise complies with the provisions of any law or acts unless the manufacturer so warrants. In no event shall Grizzly's liability under this warranty exceed the purchase price paid for the product and any legal actions brought against Grizzly shall be tried in the State of Washington, County of Whatcom.

We shall in no event be liable for death, injuries to persons or property or for incidental, contingent, special, or consequential damages arising from the use of our products.

To take advantage of this warranty, contact us by mail or phone and give us all the details. We will then issue you a "Return Number," which must be clearly posted on the outside as well as the inside of the carton. We will not accept any item back without this number. Proof of purchase must accompany the merchandise.

The manufacturers reserve the right to change specifications at any time because they constantly strive to achieve better quality equipment. We make every effort to ensure that our products meet high quality and durability standards and we hope you never need to use this warranty.

Please feel free to write or call us if you have any questions about the machine or the manual.

Thank you again for your business and continued support. We hope to serve you again soon.

grizzly.com[®]
TOOL WEBSITE

Buy Direct and Save with Grizzly[®] – Trusted, Proven and a Great Value!
~Since 1983~

*Visit Our Website Today For
Current Specials!*

**ORDER
24 HOURS A DAY!
1-800-523-4777**

