

# *Grizzly* *Industrial, Inc.*®

## MODEL G0716 10" DRUM SANDER OWNER'S MANUAL



COPYRIGHT © NOVEMBER, 2010 BY GRIZZLY INDUSTRIAL, INC., REVISED FEBRUARY, 2018 (HE)  
**WARNING: NO PORTION OF THIS MANUAL MAY BE REPRODUCED IN ANY SHAPE  
OR FORM WITHOUT THE WRITTEN APPROVAL OF GRIZZLY INDUSTRIAL, INC.**  
(FOR MODELS MANUFACTURED SINCE 2/18) #TS13385 PRINTED IN CHINA

V3.02.18



## **WARNING!**

**This manual provides critical safety instructions on the proper setup, operation, maintenance, and service of this machine/tool. Save this document, refer to it often, and use it to instruct other operators.**

**Failure to read, understand and follow the instructions in this manual may result in fire or serious personal injury—including amputation, electrocution, or death.**

**The owner of this machine/tool is solely responsible for its safe use. This responsibility includes but is not limited to proper installation in a safe environment, personnel training and usage authorization, proper inspection and maintenance, manual availability and comprehension, application of safety devices, cutting/sanding/grinding tool integrity, and the usage of personal protective equipment.**

**The manufacturer will not be held liable for injury or property damage from negligence, improper training, machine modifications or misuse.**



## **WARNING!**

**Some dust created by power sanding, sawing, grinding, drilling, and other construction activities contains chemicals known to the State of California to cause cancer, birth defects or other reproductive harm. Some examples of these chemicals are:**

- **Lead from lead-based paints.**
- **Crystalline silica from bricks, cement and other masonry products.**
- **Arsenic and chromium from chemically-treated lumber.**

**Your risk from these exposures varies, depending on how often you do this type of work. To reduce your exposure to these chemicals: Work in a well ventilated area, and work with approved safety equipment, such as those dust masks that are specially designed to filter out microscopic particles.**

# Table of Contents

<b>INTRODUCTION</b> .....	<b>2</b>	<b>SECTION 5: ACCESSORIES</b> .....	<b>28</b>
Manual Accuracy .....	2	<b>SECTION 6: MAINTENANCE</b> .....	<b>29</b>
Contact Info .....	2	Schedule .....	29
Machine Description .....	2	General Cleaning .....	29
Identification .....	3	Cleaning Sandpaper .....	29
Machine Data Sheet .....	4	Lubrication .....	29
<b>SECTION 1: SAFETY</b> .....	<b>6</b>	<b>SECTION 7: SERVICE</b> .....	<b>30</b>
Safety Instructions for Machinery .....	6	Troubleshooting .....	30
Additional Safety for Drum Sanders .....	8	Conveyor Belt Tension & Tracking .....	33
<b>SECTION 2: POWER SUPPLY</b> .....	<b>9</b>	Belt Tension .....	33
Availability .....	9	Belt Tracking .....	33
Full-Load Current Rating .....	9	Gib Adjustment .....	34
Circuit Requirements .....	9	Conveyor Belt to Drum Alignment .....	35
Grounding & Plug Requirements .....	10	Pressure Roller Adjustment .....	36
Extension Cords .....	10	Adjusting Elevation Stop .....	37
<b>SECTION 3: SETUP</b> .....	<b>11</b>	Conveyor Belt Replacement .....	38
Needed for Setup .....	11	<b>SECTION 8: WIRING</b> .....	<b>39</b>
Unpacking .....	11	Wiring Safety Instructions .....	39
Inventory .....	12	G0716 Wiring Diagram .....	40
Hardware Recognition Chart .....	13	<b>SECTION 9: PARTS</b> .....	<b>41</b>
Site Considerations .....	14	Stand .....	41
Assembly .....	15	Conveyor .....	42
Dust Collection .....	18	Main .....	44
Power Connection .....	18	Machine Labels .....	46
Connecting Power .....	18	<b>WARRANTY AND RETURNS</b> .....	<b>49</b>
Disconnecting Power .....	18		
Test Run .....	19		
Recommended Adjustments .....	19		
<b>SECTION 4: OPERATIONS</b> .....	<b>20</b>		
Basic Controls .....	20		
Workpiece Inspection .....	21		
Sandpaper .....	21		
Selection .....	21		
Replacement .....	22		
Depth of Cut .....	25		
Feed Rate .....	26		
Sanding Tips .....	26		
Sanding Operation .....	27		

# INTRODUCTION

## Manual Accuracy

We are proud to provide a high-quality owner's manual with your new machine!

We made every effort to be exact with the instructions, specifications, drawings, and photographs in this manual. Sometimes we make mistakes, but our policy of continuous improvement also means that **sometimes the machine you receive is slightly different than shown in the manual.**

If you find this to be the case, and the difference between the manual and machine leaves you confused or unsure about something, check our website for an updated version. We post current manuals and manual updates for free on our website at **www.grizzly.com**.

Alternatively, you can call our Technical Support for help. Before calling, make sure you write down the **Manufacture Date** and **Serial Number** from the machine ID label (see below). This information is required for us to provide proper tech support, and it helps us determine if updated documentation is available for your machine.

**Grizzly Industrial** MODEL GXXXX MACHINE NAME

**WARNING!**

To reduce risk of serious injury when using this machine:

1. Read manual before operation.
2. Wear safety glasses and respirator.
3. Make sure machine is properly adjusted/setup and power is connected to grounded circuit before starting.
4. Make sure the motor has stopped and disconnect power before adjustments, maintenance, or service.
5. DO NOT expose to rain or dampness.
6. DO NOT modify this machine in any way.
- 7.
- 8.
9. Do not use while impaired by alcohol or drugs.
10. Maintain machine carefully to prevent accidents.

**Manufacture Date**

**Serial Number**

Motor: \_\_\_\_\_  
Specification: \_\_\_\_\_  
Specification: \_\_\_\_\_  
Specification: \_\_\_\_\_  
Weight: \_\_\_\_\_  
Date: \_\_\_\_\_

Manufactured for Grizzly in Taiwan

## Contact Info

We stand behind our machines! If you have questions or need help, contact us with the information below. Before contacting, make sure you get the **serial number** and **manufacture date** from the machine ID label. This will help us help you faster.

Grizzly Technical Support  
1815 W. Battlefield  
Springfield, MO 65807  
Phone: (570) 546-9663  
Email: techsupport@grizzly.com

We want your feedback on this manual. What did you like about it? Where could it be improved? Please take a few minutes to give us feedback.

Grizzly Documentation Manager  
P.O. Box 2069  
Bellingham, WA 98227-2069  
Email: manuals@grizzly.com

## Machine Description

The Model G0716 drum sander features a variable speed conveyor belt that feeds the workpiece into the rotating sanding drum. The amount of material removal (depth of cut) is controlled by the elevation handwheel with the aid of the elevation pointer and scale.

For easy mobility, the lifting handles and wheels allow the sander to be moved where needed. The efficient dust collection hood allows the sawdust from the sanding operation to be removed by a dust collector.



# Identification

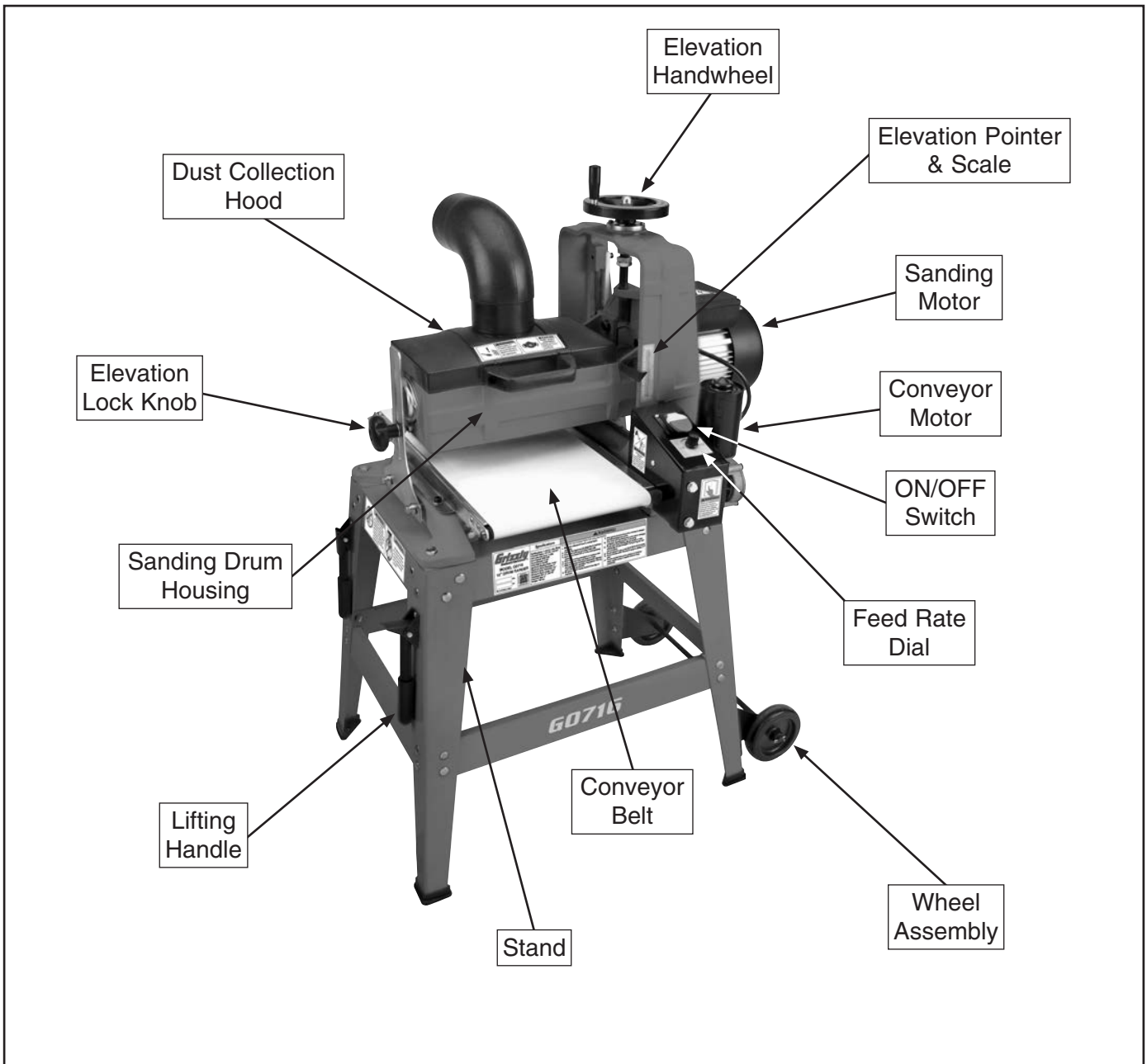
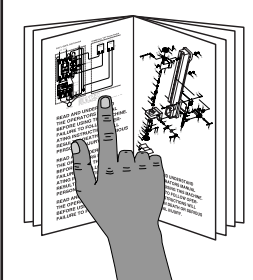

Figure 1. Model G0716 identification.

	<p><b>⚠ WARNING</b></p> <p>To reduce the risk of serious injury when using this machine, read and understand this entire manual before beginning any operations.</p>
---	--





# MACHINE DATA SHEET

Customer Service #: (570) 546-9663 · To Order Call: (800) 523-4777 · Fax #: (800) 438-5901

## MODEL G0716 10" 1 HP DRUM SANDER

### Product Dimensions:

Weight..... 159 lbs.  
 Width (side-to-side) x Depth (front-to-back) x Height..... 28-3/8 x 23-1/4 x 47-1/4 in.  
 Footprint (Length x Width)..... 17-1/2 x 13-1/2 in.

### Shipping Dimensions:

Type..... Wood Slat Crate  
 Content..... Machine  
 Weight..... 220 lbs.  
 Length x Width x Height..... 25 x 31 x 25 in.

### Electrical:

Power Requirement..... 110V, Single-Phase, 60 Hz  
 Prewired Voltage..... 110V  
 Full-Load Current Rating..... 10.72A  
 Minimum Circuit Size..... 15A  
 Connection Type..... Cord & Plug  
 Power Cord Included..... Yes  
 Power Cord Length..... 10 ft.  
 Power Cord Gauge..... 16 AWG  
 Plug Included..... Yes  
 Included Plug Type..... 5-15  
 Switch Type..... Paddle Safety Switch w/Removable Key

### Motors:

#### Feed

Horsepower..... 1/10 HP  
 Amps..... 0.72A  
 Type..... Universal  
 Power Transfer ..... Gear Drive  
 Bearings..... Sealed & Permanently Lubricated  
 Centrifugal Switch/Contacts Type..... N/A

#### Main

Horsepower..... 1 HP  
 Phase..... Single-Phase  
 Amps..... 10A  
 Speed..... 1700 RPM  
 Type..... PSC Induction  
 Power Transfer ..... Direct Drive  
 Bearings..... Sealed & Permanently Lubricated



**Main Specifications:**

**Operation Information**

Number of Sanding Heads.....	1
Maximum Board Width.....	9-1/2 in.
Minimum Board Width.....	2 in.
Maximum Board Thickness.....	3 in.
Minimum Board Thickness.....	1/4 in.
Minimum Board Length.....	4-3/4 in.
Sandpaper Speed.....	2300 FPM
Conveyor Feed Rate.....	0 – 10 FPM
Sandpaper Length.....	62-1/2 in.
Sandpaper Width.....	3 in.

**Drum Information**

Infeed Sanding Drum Size.....	5-1/8 in.
-------------------------------	-----------

**Construction**

Conveyor Belt.....	Rubber
Body.....	Cast Iron, Steel, and Aluminum
Base.....	Steel
Paint Type/Finish.....	Powder Coated & Enamel

**Other Related Information**

Floor To Table Height.....	27-1/8 in.
Sanding Belt Tension.....	Spring Loaded
Number of Pressure Rollers.....	2
Conveyor Belt Length.....	41-1/4 in.
Conveyor Belt Width.....	10 in.
Belt Roller Size.....	3/4 in.
Number of Dust Ports.....	1
Dust Port Size.....	4 in.

**Other Specifications:**

Country of Origin .....	China
Warranty .....	1 Year
Approximate Assembly & Setup Time .....	1 Hour
Serial Number Location .....	ID Label on Headstock
Sound Rating .....	80 dB
ISO 9001 Factory .....	Yes
Certified by a Nationally Recognized Testing Laboratory (NRTL) .....	No

**Features:**

- Spring-Loaded Belt Tension/Sandpaper
- Rubber Conveyor Belt
- 4" Quick Disconnect Smooth Sweep Dust Port
- Variable Speed Conveyor
- Direct Drive Main Motor; Gear Drive Feed Motor
- 5-1/8" Aluminum Sanding Drum
- Green Powder Coated Paint
- Wheels and Stowable Handles for Mobility
- fdsfdf



# SECTION 1: SAFETY

## For Your Own Safety, Read Instruction Manual Before Operating This Machine

The purpose of safety symbols is to attract your attention to possible hazardous conditions. This manual uses a series of symbols and signal words intended to convey the level of importance of the safety messages. The progression of symbols is described below. Remember that safety messages by themselves do not eliminate danger and are not a substitute for proper accident prevention measures. Always use common sense and good judgment.

**⚠ DANGER** Indicates an imminently hazardous situation which, if not avoided, **WILL** result in death or serious injury.

**⚠ WARNING** Indicates a potentially hazardous situation which, if not avoided, **COULD** result in death or serious injury.

**⚠ CAUTION** Indicates a potentially hazardous situation which, if not avoided, **MAY** result in minor or moderate injury. It may also be used to alert against unsafe practices.

**NOTICE** Alerts the user to useful information about proper operation of the machine to avoid machine damage.

## Safety Instructions for Machinery

### ⚠ WARNING

**OWNER'S MANUAL.** Read and understand this owner's manual **BEFORE** using machine.

**TRAINED OPERATORS ONLY.** Untrained operators have a higher risk of being hurt or killed. Only allow trained/supervised people to use this machine. When machine is not being used, disconnect power, remove switch keys, or lock-out machine to prevent unauthorized use—especially around children. Make your workshop kid proof!

**DANGEROUS ENVIRONMENTS.** Do not use machinery in areas that are wet, cluttered, or have poor lighting. Operating machinery in these areas greatly increases the risk of accidents and injury.

**MENTAL ALERTNESS REQUIRED.** Full mental alertness is required for safe operation of machinery. Never operate under the influence of drugs or alcohol, when tired, or when distracted.

**ELECTRICAL EQUIPMENT INJURY RISKS.** You can be shocked, burned, or killed by touching live electrical components or improperly grounded machinery. To reduce this risk, only allow qualified service personnel to do electrical installation or repair work, and always disconnect power before accessing or exposing electrical equipment.

**DISCONNECT POWER FIRST.** Always disconnect machine from power supply **BEFORE** making adjustments, changing tooling, or servicing machine. This prevents an injury risk from unintended startup or contact with live electrical components.

**EYE PROTECTION.** Always wear ANSI-approved safety glasses or a face shield when operating or observing machinery to reduce the risk of eye injury or blindness from flying particles. Everyday eyeglasses are **NOT** approved safety glasses.





# WARNING

**WEARING PROPER APPAREL.** Do not wear clothing, apparel or jewelry that can become entangled in moving parts. Always tie back or cover long hair. Wear non-slip footwear to reduce risk of slipping and losing control or accidentally contacting cutting tool or moving parts.

**HAZARDOUS DUST.** Dust created by machinery operations may cause cancer, birth defects, or long-term respiratory damage. Be aware of dust hazards associated with each workpiece material. Always wear a NIOSH-approved respirator to reduce your risk.

**HEARING PROTECTION.** Always wear hearing protection when operating or observing loud machinery. Extended exposure to this noise without hearing protection can cause permanent hearing loss.

**REMOVE ADJUSTING TOOLS.** Tools left on machinery can become dangerous projectiles upon startup. Never leave chuck keys, wrenches, or any other tools on machine. Always verify removal before starting!

**USE CORRECT TOOL FOR THE JOB.** Only use this tool for its intended purpose—do not force it or an attachment to do a job for which it was not designed. Never make unapproved modifications—modifying tool or using it differently than intended may result in malfunction or mechanical failure that can lead to personal injury or death!

**AWKWARD POSITIONS.** Keep proper footing and balance at all times when operating machine. Do not overreach! Avoid awkward hand positions that make workpiece control difficult or increase the risk of accidental injury.

**CHILDREN & BYSTANDERS.** Keep children and bystanders at a safe distance from the work area. Stop using machine if they become a distraction.

**GUARDS & COVERS.** Guards and covers reduce accidental contact with moving parts or flying debris. Make sure they are properly installed, undamaged, and working correctly BEFORE operating machine.

**FORCING MACHINERY.** Do not force machine. It will do the job safer and better at the rate for which it was designed.

**NEVER STAND ON MACHINE.** Serious injury may occur if machine is tipped or if the cutting tool is unintentionally contacted.

**STABLE MACHINE.** Unexpected movement during operation greatly increases risk of injury or loss of control. Before starting, verify machine is stable and mobile base (if used) is locked.

**USE RECOMMENDED ACCESSORIES.** Consult this owner's manual or the manufacturer for recommended accessories. Using improper accessories will increase the risk of serious injury.

**UNATTENDED OPERATION.** To reduce the risk of accidental injury, turn machine **OFF** and ensure all moving parts completely stop before walking away. Never leave machine running while unattended.

**MAINTAIN WITH CARE.** Follow all maintenance instructions and lubrication schedules to keep machine in good working condition. A machine that is improperly maintained could malfunction, leading to serious personal injury or death.

**DAMAGED PARTS.** Regularly inspect machine for damaged, loose, or mis-adjusted parts—or any condition that could affect safe operation. Immediately repair/replace BEFORE operating machine. For your own safety, DO NOT operate machine with damaged parts!

**MAINTAIN POWER CORDS.** When disconnecting cord-connected machines from power, grab and pull the plug—NOT the cord. Pulling the cord may damage the wires inside. Do not handle cord/plug with wet hands. Avoid cord damage by keeping it away from heated surfaces, high traffic areas, harsh chemicals, and wet/damp locations.

**EXPERIENCING DIFFICULTIES.** If at any time you experience difficulties performing the intended operation, stop using the machine! Contact our Technical Support at (570) 546-9663.



# Additional Safety for Drum Sanders

## **WARNING**

Serious injury or death can occur from getting hands trapped between workpiece and conveyor table and being pulled into machine, or becoming entangled in rotating parts inside machine. Workpieces thrown by sander can strike nearby operator or bystanders with significant force. Long-term respiratory damage can occur from using sander without proper use of a respirator. To reduce the risk of these hazards, operator and bystanders **MUST** completely heed the hazards and warnings below.

**FEEDING WORKPIECE.** Placing fingers between workpiece and conveyor can result in pinching injuries, or possibly getting trapped and pulled into sanding area of machine. **DO NOT** place fingers under bottom of workpiece while feeding it into sander.

**SANDING DUST.** Sanding creates large amounts of fine airborne dust that can lead to eye injury or serious respiratory illness. Reduce your risk by always wearing approved eye and respiratory protection when sanding. Never operate without adequate dust collection system in place and running. However, dust collection is not a substitute for using a respirator.

**POWER DISCONNECT.** An accidental startup while changing sanding belts or performing adjustments or maintenance can result in entanglement or abrasion injuries. Make sure machine is turned **OFF**, disconnected from power and air, and all moving parts are completely stopped before changing belts, doing adjustments, or performing maintenance.

**KICKBACK.** Occurs when a workpiece is ejected out the front of sander at a high rate of speed toward operator or bystanders. To reduce risk of kickback-related injuries, always stay out of workpiece path, only feed one board at a time, and always make sure pressure rollers are properly adjusted below sanding roller. Never sand workpieces below minimum specifications listed in **Machine Data Sheet**.

**AVOIDING ENTANGLEMENT.** Tie back long hair, remove jewelry, and do not wear loose clothing or gloves. These can easily get caught in moving parts. Never reach inside machine or try to clear jammed workpiece while machine is operating. Keep all guards in place and secure.

**SANDPAPER CONTACT.** Rotating sandpaper can remove a large amount of flesh quickly. Keep hands away from rotating sanding drum(s) during operation. Never touch moving sandpaper.

## **WARNING**

Like all machinery there is potential danger when operating this machine. Accidents are frequently caused by lack of familiarity or failure to pay attention. Use this machine with respect and caution to decrease the risk of operator injury. If normal safety precautions are overlooked or ignored, serious personal injury may occur.

## **CAUTION**

No list of safety guidelines can be complete. Every shop environment is different. Always consider safety first, as it applies to your individual working conditions. Use this and other machinery with caution and respect. Failure to do so could result in serious personal injury, damage to equipment, or poor work results.



# SECTION 2: POWER SUPPLY

## Availability

Before installing the machine, consider the availability and proximity of the required power supply circuit. If an existing circuit does not meet the requirements for this machine, a new circuit must be installed. To minimize the risk of electrocution, fire, or equipment damage, installation work and electrical wiring must be done by an electrician or qualified service personnel in accordance with all applicable codes and standards.

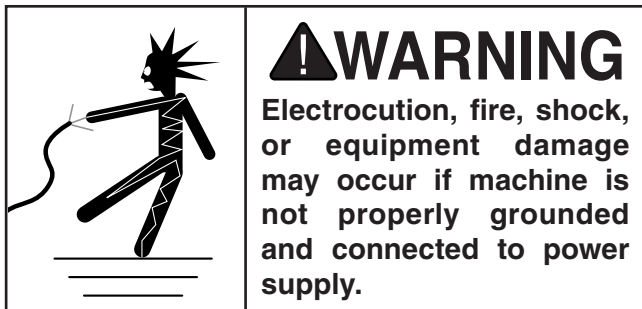

## Full-Load Current Rating

The full-load current rating is the amperage a machine draws at 100% of the rated output power. On machines with multiple motors, this is the amperage drawn by the largest motor or sum of all motors and electrical devices that might operate at one time during normal operations.

### Full-Load Current Rating at 110V. 10.72 Amps

The full-load current is not the maximum amount of amps that the machine will draw. If the machine is overloaded, it will draw additional amps beyond the full-load rating.

If the machine is overloaded for a sufficient length of time, damage, overheating, or fire may result—especially if connected to an undersized circuit. To reduce the risk of these hazards, avoid overloading the machine during operation and make sure it is connected to a power supply circuit that meets the specified circuit requirements.

## Circuit Requirements

This machine is prewired to operate on a power supply circuit that has a verified ground and meets the following requirements:

**Nominal Voltage** ..... 110V/120V  
**Cycle** ..... 60 Hz  
**Phase** ..... Single-Phase  
**Minimum Circuit Size** ..... 15 Amps

A power supply circuit includes all electrical equipment between the breaker box or fuse panel in the building and the machine. The power supply circuit used for this machine must be sized to safely handle the full-load current drawn from the machine for an extended period of time. (If this machine is connected to a circuit protected by fuses, use a time delay fuse marked D.)



**Note:** *Circuit requirements in this manual apply to a dedicated circuit—where only one machine will be running on the circuit at a time. If machine will be connected to a shared circuit where multiple machines may be running at the same time, consult an electrician or qualified service personnel to ensure circuit is properly sized for safe operation.*



## Grounding & Plug Requirements

This machine **MUST** be grounded. In the event of certain malfunctions or breakdowns, grounding reduces the risk of electric shock by providing a path of least resistance for electric current.

This machine is equipped with a power cord that has an equipment-grounding wire and a grounding plug. Only insert plug into a matching receptacle (outlet) that is properly installed and grounded in accordance with all local codes and ordinances. **DO NOT** modify the provided plug!

**⚠ WARNING**  
Serious injury could occur if you connect machine to power before completing setup process. **DO NOT** connect to power until instructed later in this manual.

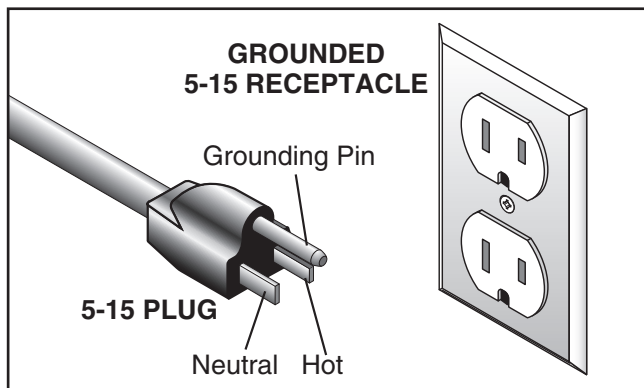

Figure 2. Typical 5-15 plug and receptacle.

**⚠ CAUTION**

**SHOCK HAZARD!**  
Two-prong outlets do not meet the grounding requirements for this machine. Do not modify or use an adapter on the plug provided—if it will not fit the outlet, have a qualified electrician install the proper outlet with a verified ground.

Improper connection of the equipment-grounding wire can result in a risk of electric shock. The wire with green insulation (with or without yellow stripes) is the equipment-grounding wire. If repair or replacement of the power cord or plug is necessary, do not connect the equipment-grounding wire to a live (current carrying) terminal.

Check with a qualified electrician or service personnel if you do not understand these grounding requirements, or if you are in doubt about whether the tool is properly grounded. If you ever notice that a cord or plug is damaged or worn, disconnect it from power, and immediately replace it with a new one.

## Extension Cords

We do not recommend using an extension cord with this machine. If you must use an extension cord, only use it if absolutely necessary and only on a temporary basis.

Extension cords cause voltage drop, which can damage electrical components and shorten motor life. Voltage drop increases as the extension cord size gets longer and the gauge size gets smaller (higher gauge numbers indicate smaller sizes).

Any extension cord used with this machine must be in good condition and contain a ground wire and matching plug/receptacle. Additionally, it must meet the following size requirements:

**Minimum Gauge Size ..... 14 AWG**  
**Maximum Length (Shorter is Better).....50 ft.**



# SECTION 3: SETUP

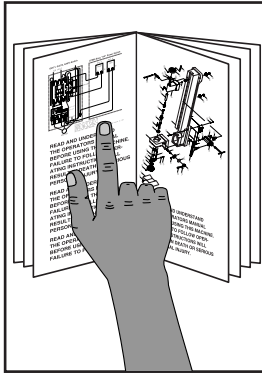

**!WARNING**  
This machine presents serious injury hazards to untrained users. Read through this entire manual to become familiar with the controls and operations before starting the machine!



**!WARNING**  
Wear safety glasses during the entire setup process!

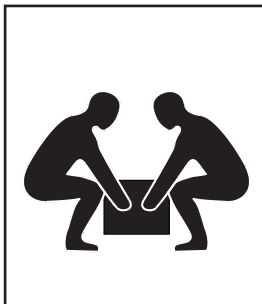

**!WARNING**  
This machine and its components are very heavy. Get lifting help or use power lifting equipment such as a forklift to move heavy items.

## Needed for Setup

The following are needed to complete the setup process, but are not included with your machine.

Description	Qty
• Safety Glasses .....	1
• Additional People (for lifting) .....	1
• Phillips Screwdriver #2 .....	1
• Wrench/Socket 10mm .....	1
• Wrench/Socket 13mm .....	2
• Wrench/Socket 16mm .....	2
• Needle-Nose Pliers .....	1
• Dust Collection System .....	1
• Dust Hose 4" .....	1
• Hose Clamps 4" .....	2

## Unpacking

Your machine was carefully packaged for safe transportation. Remove the packaging materials from around your machine and inspect it. If you discover the machine is damaged, *please immediately call Customer Service at (570) 546-9663 for advice.*

Save the containers and all packing materials for possible inspection by the carrier or its agent. *Otherwise, filing a freight claim can be difficult.*

When you are completely satisfied with the condition of your shipment, inventory the contents.



**!WARNING**  
**SUFFOCATION HAZARD!**  
Keep children and pets away from plastic bags or packing materials shipped with this machine.



# Inventory

The following is a list of items shipped with your machine. Before beginning setup, lay these items out and inventory them.

If any non-proprietary parts are missing (e.g. a nut or a washer), we will gladly replace them; or for the sake of expediency, replacements can be obtained at your local hardware store.

**Inventory: (Figure 3) Qty**

<b>A.</b>	Drum Sander Assembly (Not Shown) .....	1
<b>B.</b>	Left/Right Long Top Braces 23 $\frac{1}{8}$ " .....	2
<b>C.</b>	Wheels 4" .....	2
<b>D.</b>	Legs.....	4
<b>E.</b>	Long Bottom Braces 20 $\frac{1}{4}$ " .....	2
<b>F.</b>	Elevation Handwheel Handle .....	1
<b>G.</b>	Leg Foot Pads .....	4
<b>H.</b>	Wheel Axle .....	1
<b>I.</b>	Dust Collection 90° Elbow 4" .....	1
<b>J.</b>	Lifting Handle Assemblies.....	2
<b>K.</b>	Left/Right Wheel Brackets.....	1 Each
<b>L.</b>	Left/Right Short Top Braces 14 $\frac{5}{8}$ " .....	2
<b>M.</b>	Short Bottom Braces 17 $\frac{1}{4}$ " .....	2
<b>N.</b>	Hardware (Not Shown)	
	—Carriage Bolts M8-1.25 x 12 (Stand) ....	32
	—Lock Nuts M8-1.25 (Stand) .....	32
	—Cotter Pins 4 x 20mm (Wheels).....	2
	—Hex Bolts M8-1.25 x 16 (Wheels) .....	4
	—Lock Nuts M8-1.25 (Wheels) .....	4
	—Flat Head Screws M6-1 x 10 (Handles)..	4
	—Lock Nuts M6-1 (Handles) .....	4
	—Hex Bolts M10-1.5 x 30 (Sander).....	4
	—Flat Washer 10mm (Sander).....	4
	—Hex Nuts M10-1.5 (Sander).....	4

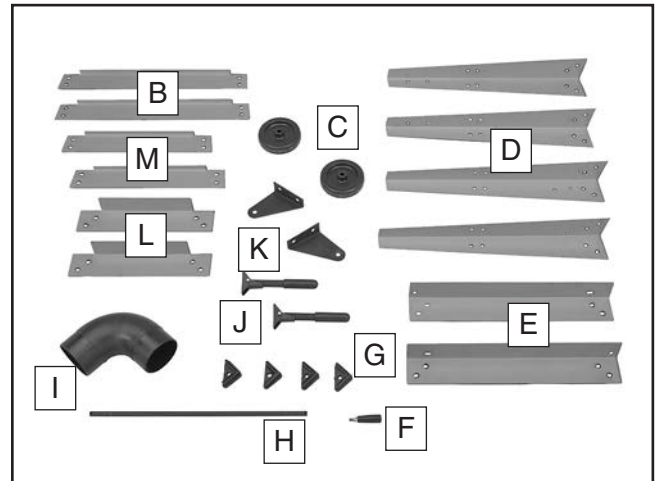

Figure 3. Small component inventory.

## NOTICE

If you cannot find an item on this list, carefully check around/inside the machine and packaging materials. Often, these items get lost in packaging materials while unpacking or they are pre-installed at the factory.



# Hardware Recognition Chart

USE THIS CHART TO MATCH UP  
HARDWARE DURING THE ASSEMBLY  
PROCESS.

MEASURE BOLT DIAMETER BY PLACING INSIDE CIRCLE

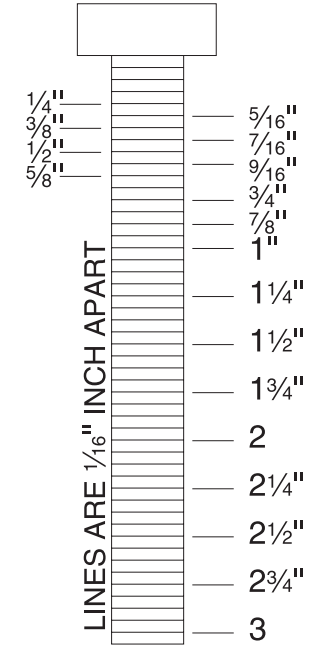
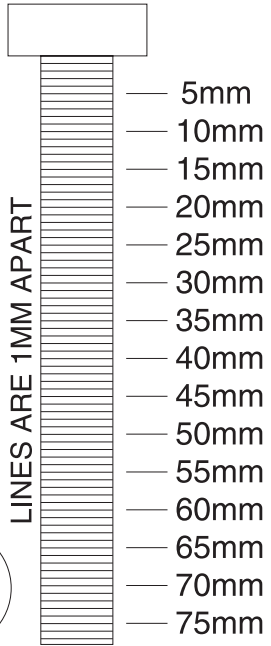
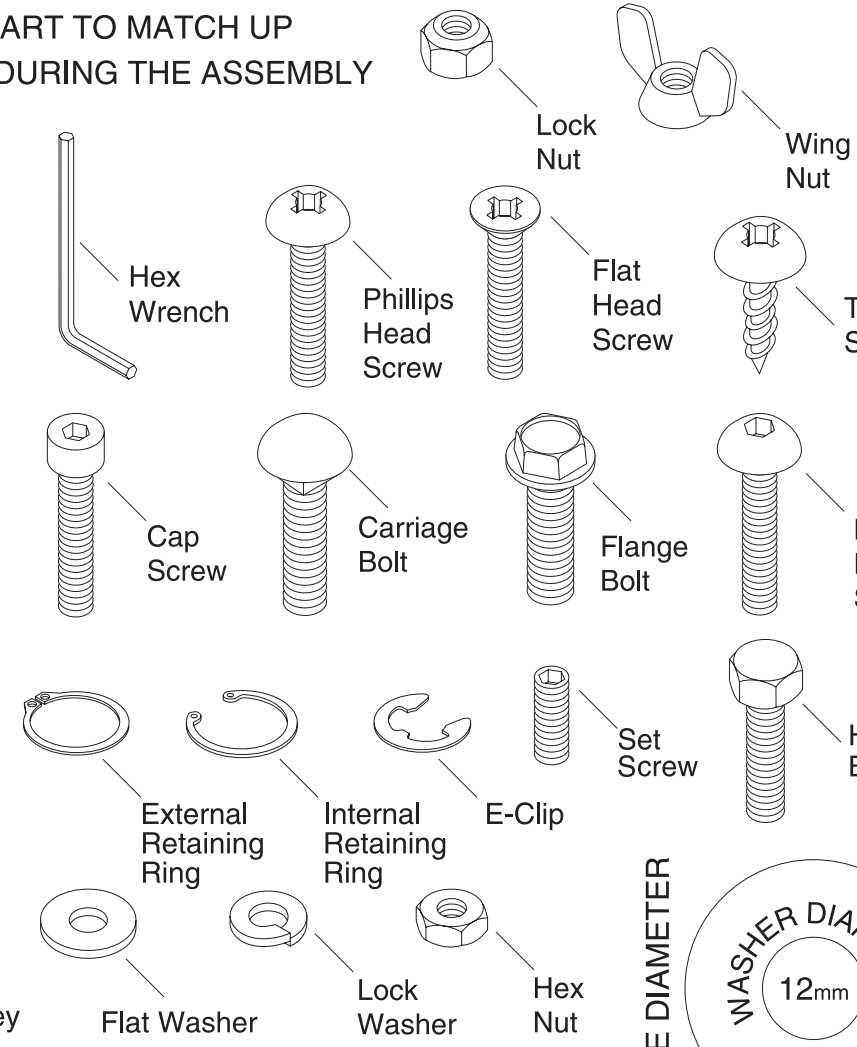
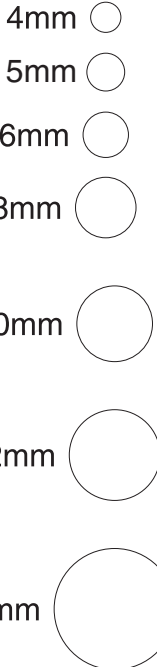
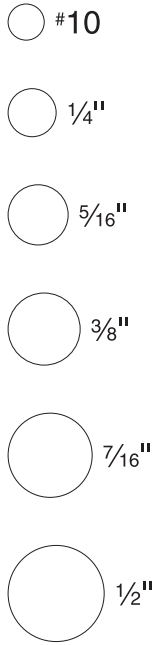

WASHERS ARE MEASURED BY THE INSIDE DIAMETER

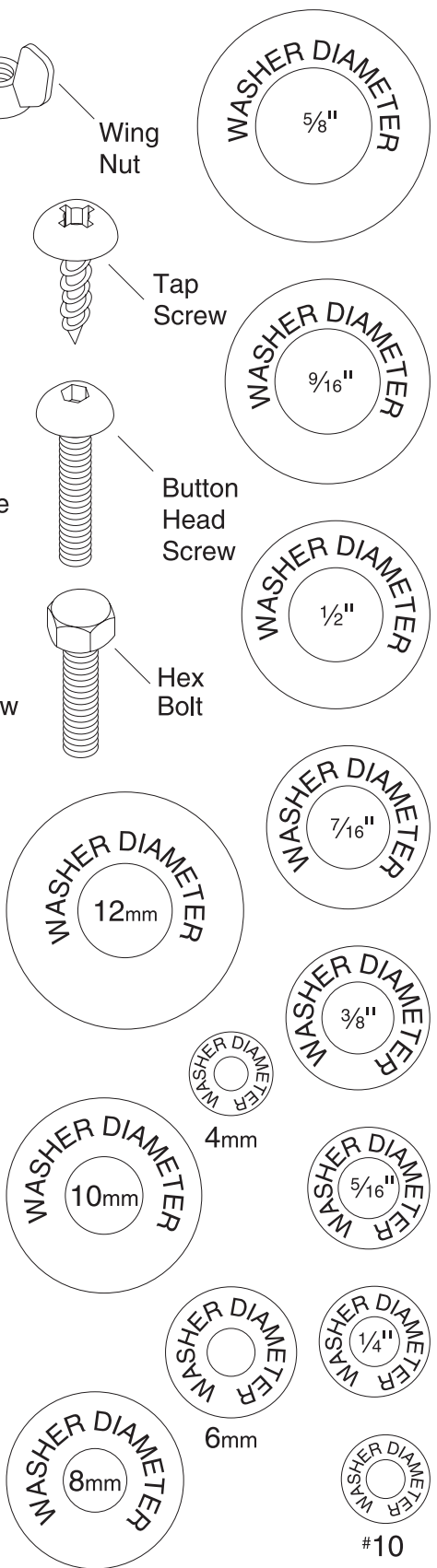

# Site Considerations

## Weight Load

Refer to the **Machine Data Sheet** for the weight of your machine. Make sure that the surface upon which the machine is placed will bear the weight of the machine, additional equipment that may be installed on the machine, and the heaviest workpiece that will be used. Additionally, consider the weight of the operator and any dynamic loading that may occur when operating the machine.

## Space Allocation

Consider the largest size of workpiece that will be processed through this machine and provide enough space around the machine for adequate operator material handling or the installation of auxiliary equipment. With permanent installations, leave enough space around the machine to open or remove doors/covers as required by the maintenance and service described in this manual. **See below for required space allocation.**

	<p><b>CAUTION</b> Children or untrained people may be seriously injured by this machine. Only install in an access restricted location.</p>
---	---

## Physical Environment

The physical environment where the machine is operated is important for safe operation and longevity of machine components. For best results, operate this machine in a dry environment that is free from excessive moisture, hazardous chemicals, airborne abrasives, or extreme conditions. Extreme conditions for this type of machinery are generally those where the ambient temperature range exceeds 41°–104°F; the relative humidity range exceeds 20%–95% (non-condensing); or the environment is subject to vibration, shocks, or bumps.

## Electrical Installation

Place this machine near an existing power source. Make sure all power cords are protected from traffic, material handling, moisture, chemicals, or other hazards. Make sure to leave enough space around machine to disconnect power supply or apply a lockout/tagout device, if required.

## Lighting

Lighting around the machine must be adequate enough that operations can be performed safely. Shadows, glare, or strobe effects that may distract or impede the operator must be eliminated.

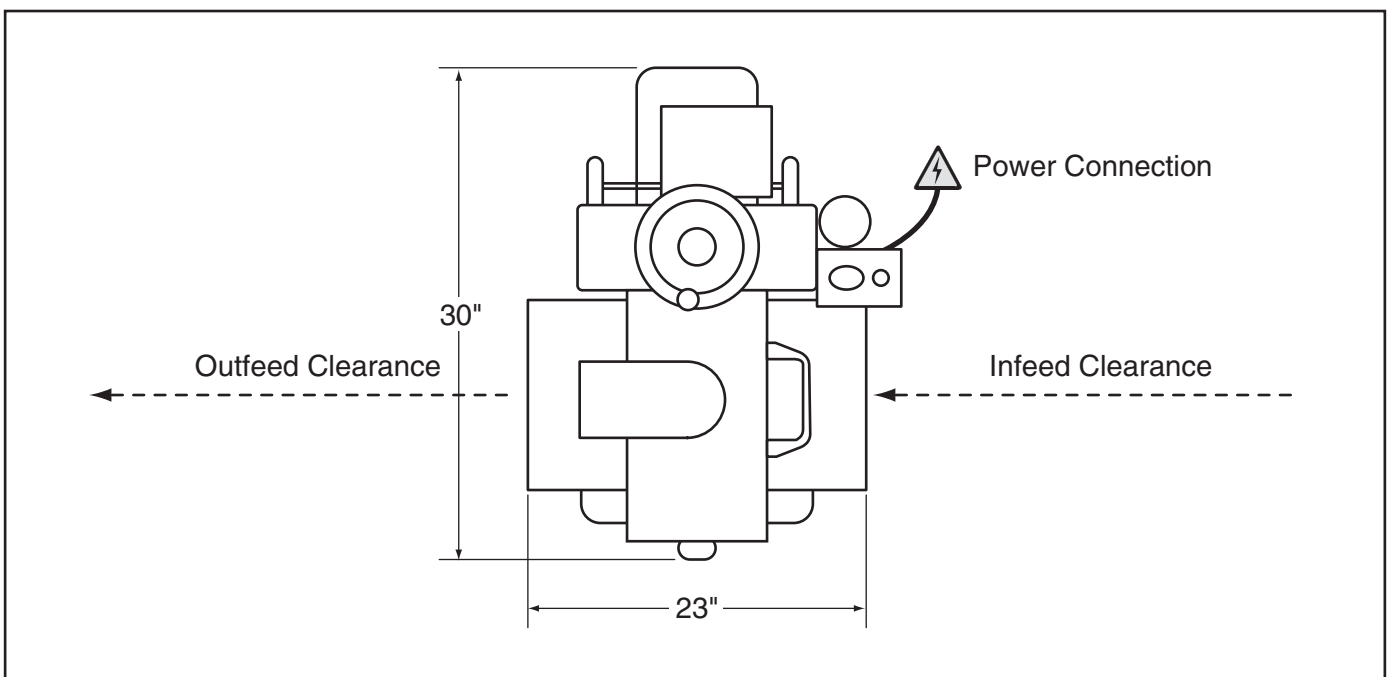

**Figure 4.** Minimum working clearances.





# Assembly

When assembling the stand for this drum sander, it is important that each part of the stand is oriented and attached in a specific way. Refer to the illustration in **Figure 6** below to gain a clear understanding of the layout for each leg and brace.

**Note:** *The parts illustrated are displayed "upside down", as they will be during the assembly steps.*

## To assemble the drum sander:

1. Position the top braces upside down on a protected surface in the form of a rectangle, then attach the legs to the braces with (16) M8-1.25 x 12 carriage bolts and M8-1.25 lock nuts, as shown in **Figure 5**. Hand tighten all fasteners for now. They will be fully tightened in **Step 4**.

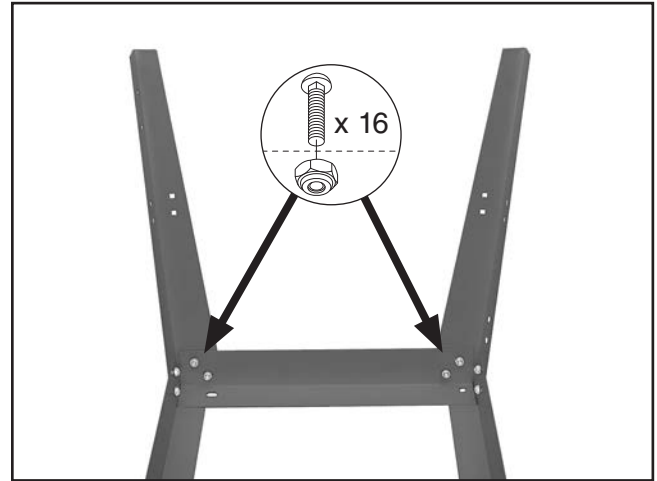

**Figure 5.** Legs attached to the top braces.

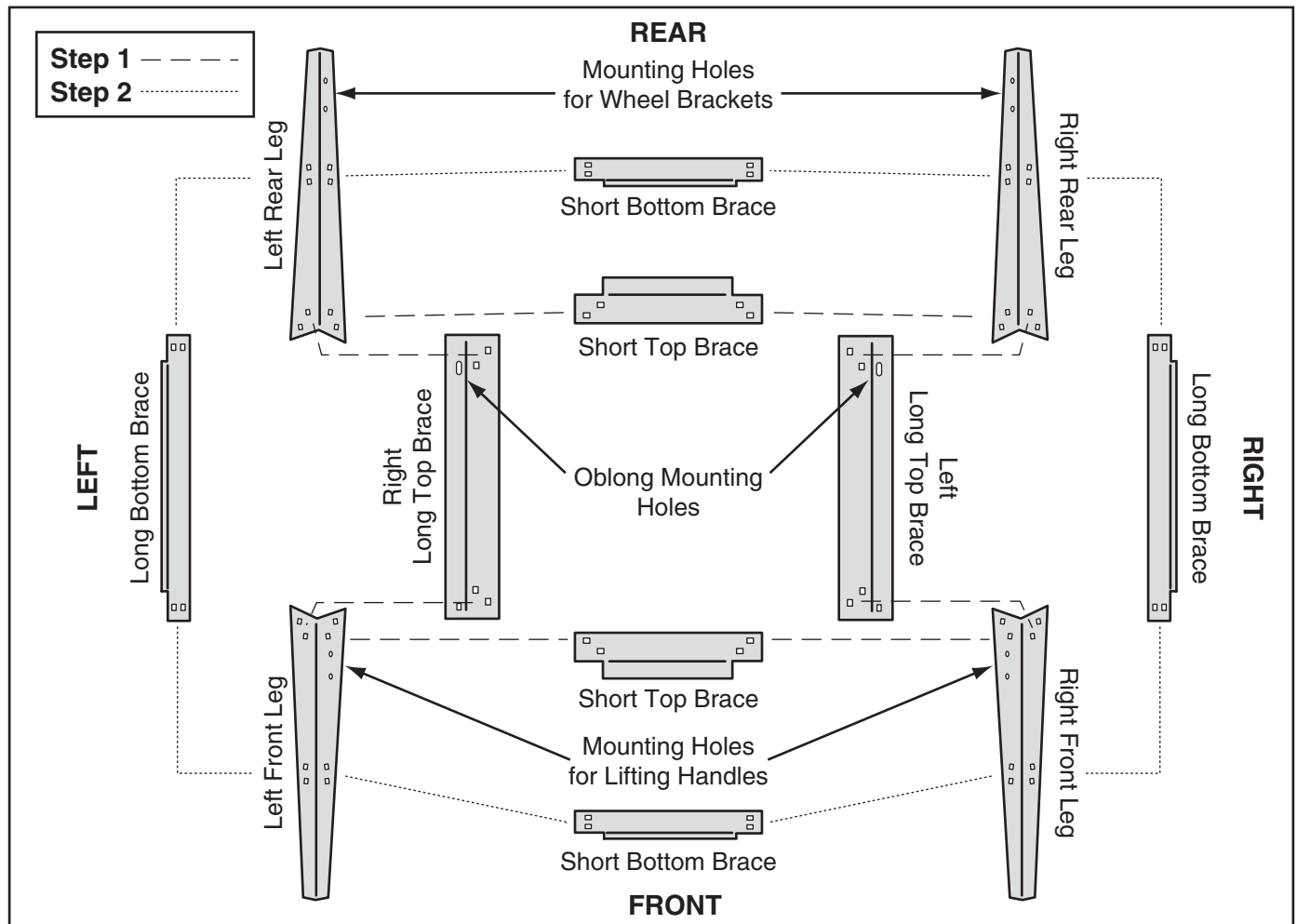

**Figure 6.** Layout and orientation of the stand legs and braces.



2. Attach the bottom braces to the legs, as shown in **Figure 7**, with the remaining (16) M8-1.25 x 12 carriage bolts and M8-1.25 lock nuts.

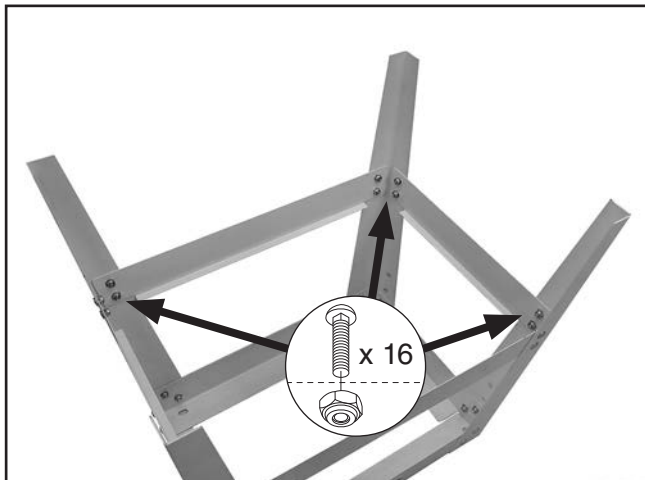

**Figure 7.** Bottom braces attached to the legs.

3. Slide the leg foot pads onto the bottom of the legs, as shown in **Figure 8**.

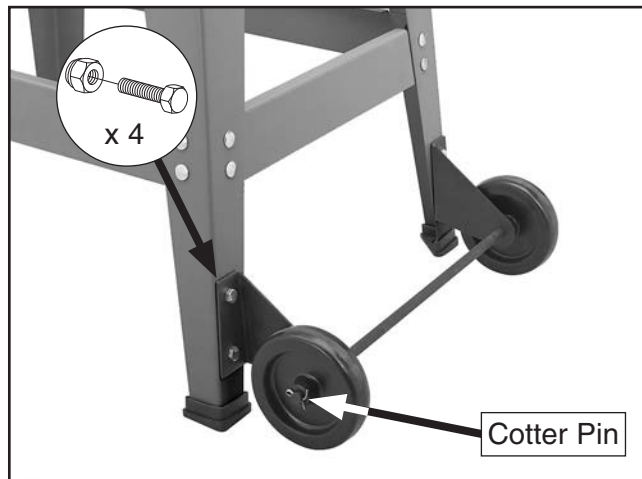

**Figure 8.** Leg foot pad installed.

4. Carefully turn the stand over, square up the legs and braces, then fully tighten all fasteners.

5. Attach the wheel brackets to the rear legs with (4) M8-1.25 x 16 hex bolts and M8-1.25 lock nuts (see **Figure 9**).

**Note:** The left and right wheel brackets are different configurations.



**Figure 9.** Wheels assemblies.

6. Slide the wheel axle through the brackets, put the wheels onto the ends of the axle, then secure them with the cotter pins by inserting them through the axle holes and bending back the ends.
7. Attach the lifting handle assemblies on the front legs with (4) M6-1 x 10 flat head screws and M6-1 lock nuts, as shown in **Figure 10**.

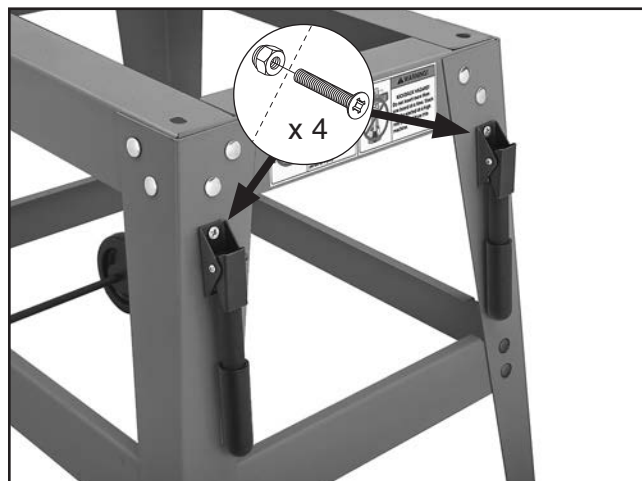

**Figure 10.** Lifting handle assemblies attached.



Optional: User can rotate sander 180 degrees and install on stand. Orienting motor on side opposite wheels may help reduce potential for machine flipping over. See 9.26.23 Email from Mike Yothers.

8. With the help of another person place the sander assembly on the stand, align the mounting holes, then place with (4) M10-1.5 x 30 hex bolts, 10mm flat washers, and M10-1.5 hex nuts (see **Figure 11**).

**Note:** If necessary to align the mounting holes, slightly loosen the stand fasteners. Be sure to re-tighten them after securing the sander assembly.

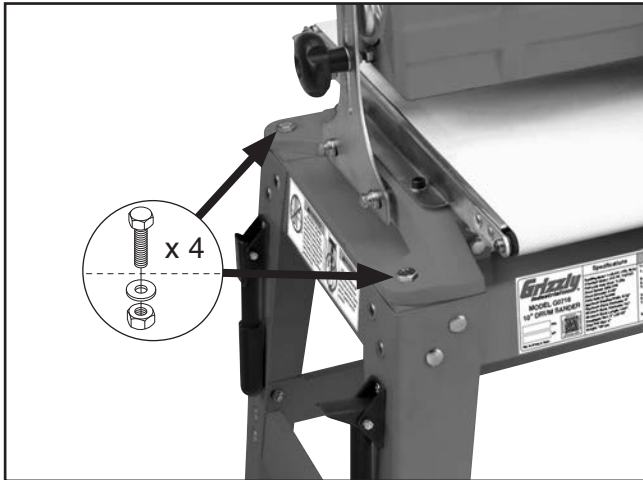

**Figure 11.** Sander assembly secured to the stand.

9. Thread the handle into the elevation handwheel, as shown in **Figure 12**.

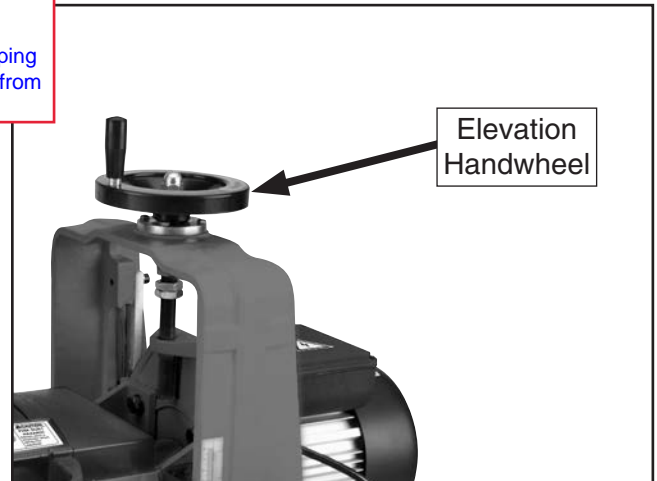

**Figure 12.** Handle installed onto the elevation handwheel.

10. Install the dust collection elbow into the dust collection hood, as shown in **Figure 13**.

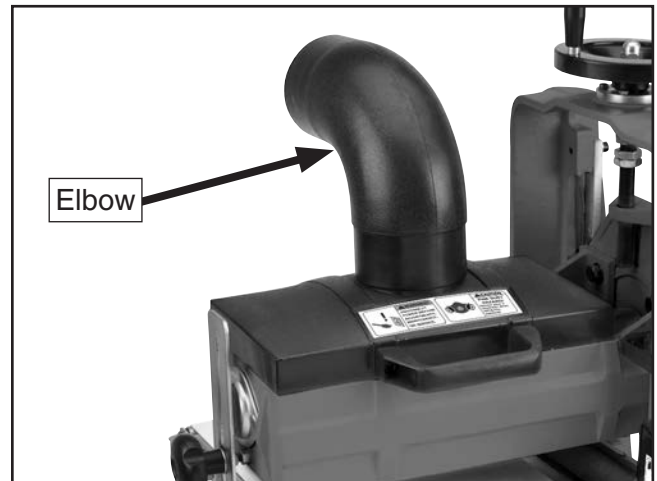

**Figure 13.** Dust collection elbow installed.



# Dust Collection

## **⚠ CAUTION**

**DO NOT** operate the Model G0716 without an adequate dust collection system. This sander creates substantial amounts of wood dust while operating. Failure to use a dust collection system can result in short and long-term respiratory illness.

### **Recommended CFM at Dust Port: 400 CFM**

*Do not confuse this CFM recommendation with the rating of the dust collector. To determine the CFM at the dust port, you must consider these variables: (1) CFM rating of the dust collector, (2) hose type and length between the dust collector and the machine, (3) number of branches or wyes, and (4) amount of other open lines throughout the system. Explaining how to calculate these variables is beyond the scope of this manual. Consult an expert or purchase a good dust collection "how-to" book.*

### **To connect a dust collection hose:**

1. Fit the 4" dust hose over the dust collection elbow, as shown in **Figure 14**, and secure in place with a hose clamp.
2. Tug the hose to make sure it does not come off. **Note:** *A tight fit is necessary for proper performance.*

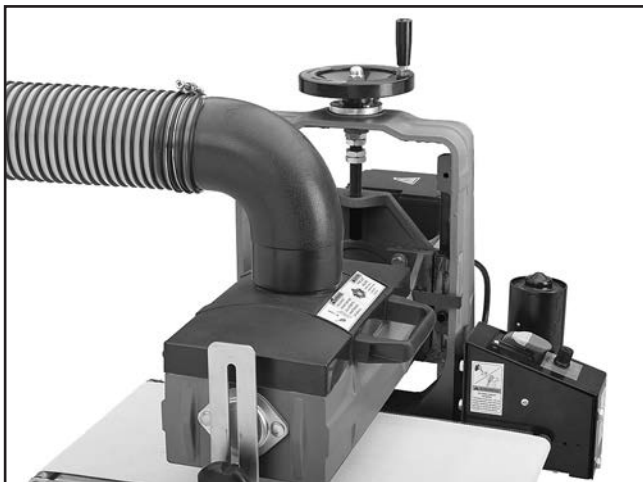

**Figure 14.** Dust hose attached to dust port.

# Power Connection

Before the machine can be connected to the power source, an electrical circuit and connection device must be prepared per the **POWER SUPPLY** section in this manual, and all previous setup instructions in this manual must be complete to ensure that the machine has been assembled and installed properly.

Always make sure the power switch on the machine is turned OFF (or the OFF button is pushed in) before connecting/disconnecting power.

## **Connecting Power**

Insert the power cord plug into a matching power supply receptacle. The machine is now connected to the power source.

## **Disconnecting Power**

If you need to disconnect the machine from power later, pull the plug completely out of the receptacle. Make sure to grasp the plug when pulling it from the receptacle—do not pull on the cord or it could become damaged.



# Test Run

---

Once the assembly is complete, test run your machine to make sure it runs properly and is ready for regular operation.

The test run consists of verifying the following:

- 1) Both motors power up and run correctly, and
- 2) the safety disabling mechanism on the switch works correctly.

If, during the test run, you cannot easily locate the source of an unusual noise or vibration, stop using the machine immediately, then review **Troubleshooting** on **Page 30**.

## To test run the machine:

1. Make sure you have read the safety instructions at the beginning of the manual and that the machine is setup properly.
2. Make sure all tools and objects used during setup are cleared away from the machine.
3. Make sure the sanding drum is safely above the conveyor belt so that it will not make contact when running.
4. Verify that the machine is operating correctly by turning it **ON**.

—When operating correctly, the machine runs smoothly with little or no vibration or rubbing noises.

—Investigate and correct strange or unusual noises or vibrations before operating the machine further. Always disconnect the machine from power when investigating or correcting potential problems.

5. Rotate the conveyor variable feed rate dial clockwise to verify the conveyor belt feed rate changes, then turn it counterclockwise until the belt stops.
6. Turn the machine **OFF**.
7. Remove the switch disabling key, as shown in **Figure 15**.

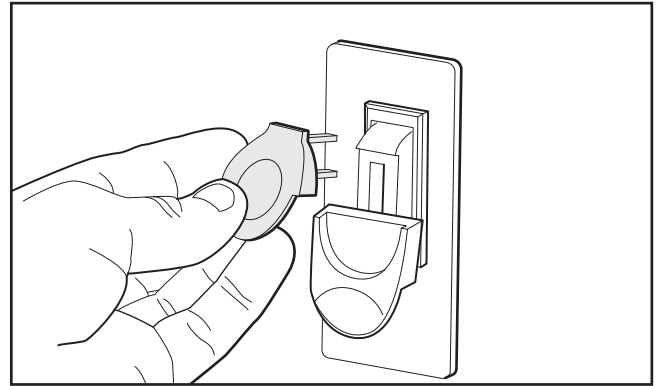

**Figure 15.** Removing switch key from paddle switch.

8. Try to turn the start the machine with the paddle switch.

—If the machine does not start, the switch disabling feature is working as designed.

—If the machine starts, immediately stop the machine. The switch disabling feature is not working correctly. This safety feature must work properly before proceeding with regular operations. Call Tech Support for help.

## Recommended Adjustments

---

For your convenience, the adjustments listed below have been performed at the factory.

However, because of the many variables involved with shipping, we recommend that you at least verify the following adjustments to ensure the best possible results from your new machine.

Step-by-step instructions for these adjustments can be found on the referenced page for each item.

### Factory adjustments that should be verified:

- Conveyor belt tension and tracking (**Page 33**)
- Gib adjustment (**Page 34**)
- Conveyor belt to drum alignment (**Page 35**)
- Pressure roller adjustment (**Page 36**)
- Adjusting elevation stop (**Page 37**)



# SECTION 4: OPERATIONS

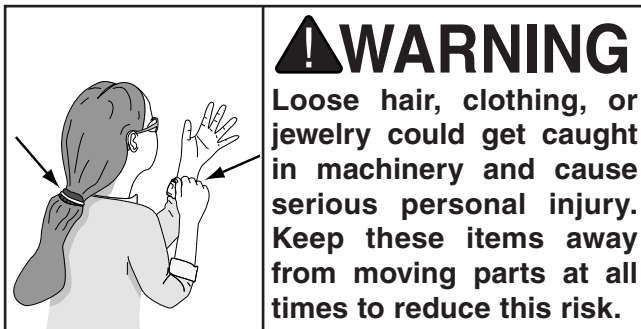
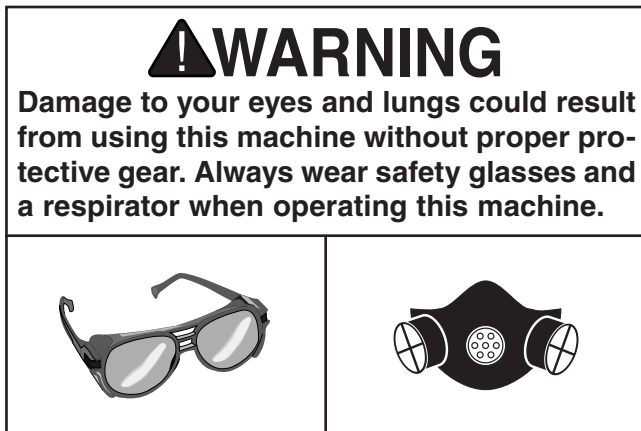
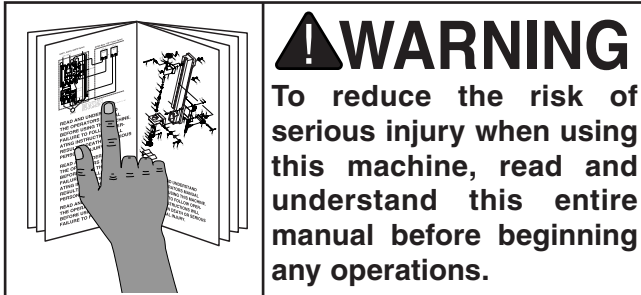

**NOTICE**

If you have never used this type of machine or equipment before, WE STRONGLY RECOMMEND that you read books, review industry trade magazines, or get formal training before beginning any projects. Regardless of the content in this section, Grizzly Industrial will not be held liable for accidents caused by lack of training.

## Basic Controls

Refer to **Figure 16** and the descriptions below to better understand the basic controls used when sanding.

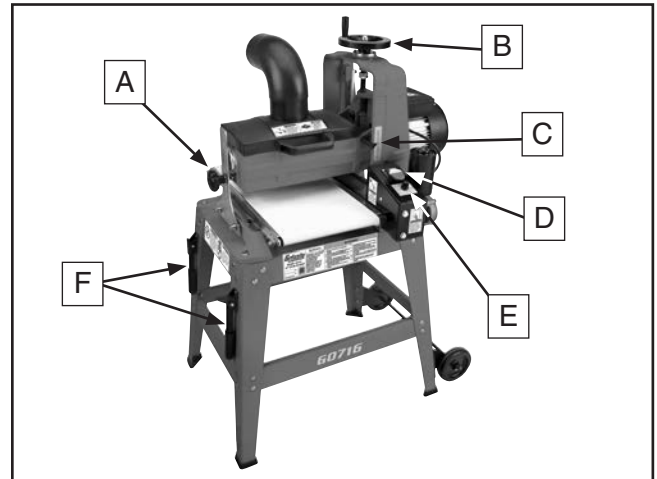

**Figure 16.** Basic controls.

- A. Elevation Lock Knob:** Secures the sanding head in place after adjusting the elevation. Additionally, this lock helps keep the sanding drum parallel to the conveyor belt during operation.
- B. Elevation Handwheel:** Adjusts the height of the sanding drum above the conveyor belt to control the depth of cut or accommodate new workpieces.
- C. Pointer & Elevation Scale:** Displays the current height of the sanding drum above the conveyor belt in inches and millimeters.
- D. ON/OFF Switch:** Controls power flow to the sanding and conveyor motors. This switch can be disabled for safety by removing the key.
- E. Conveyor Variable Feed Rate Dial:** Adjusts the feed rate of the conveyor belt from 0 to 10 FPM (Feet Per Minute).
- F. Lifting Handles:** Provides a method to lift and move the machine.



# Workpiece Inspection

Some workpieces are not safe to sand or may require modification before they are safe to sand.

**Before sanding, inspect all workpieces for the following:**

- **Material Type:** This machine is intended for sanding natural and man-made wood products. This machine is NOT designed to sand metal, glass, stone, tile, etc.; sanding these materials with a drum sander saw may lead to injury.
- **Foreign Objects:** Nails, staples, dirt, rocks and other foreign objects are often embedded in wood. While sanding, these objects can become dislodged and hit the operator, cause kickback, or damage the machine. Always visually inspect your workpiece for these items. If they can't be removed, DO NOT cut the workpiece.
- **Large/Loose Knots:** Loose knots can become dislodged during the sanding operation. Large knots can cause kickback and machine damage. Choose workpieces that do not have large/loose knots.
- **Wet or "Green" Stock:** Sanding wood with a moisture content over 20% causes unnecessary wear on the sandpaper and motors, increases the risk of kickback, and yields poor results.
- **Excessive Warping:** Workpieces with excessive cupping, bowing, or twisting are dangerous to cut because they are unstable and often unpredictable when being cut. DO NOT use workpieces with these characteristics!
- **Minor Warping:** Workpieces with slight cupping can be safely supported if the cupped side is facing the conveyor belt. On the contrary, a workpiece supported on the bowed side will rock during a cut and could cause kickback or severe injury.

# Sandpaper

## Selection

Sanding a workpiece smooth requires making progressively smaller scratches in the wood until they become too small to feel or be seen.

The abrasiveness of sandpaper is designated in grit size—the larger the number, the finer the abrasive and the smaller the scratches. Thus, 100 grit is finer than 60 grit.

Typically, sanding operations start with a coarse grit and progressively work through the finer (larger number) grits until the desired finish is achieved. Avoid skipping a grit to achieve the best results. Choosing which grit to start and finish with depends on many factors, such as the workpiece condition, type and hardness of wood, the desired finish, and others.

There are many types of sanding belts to choose from. We recommend Aluminum Oxide for general workshop environments. Below is a chart that groups abrasives into different classes and shows which grits fall into each class.

Grit	Class	Usage
36	Extra Coarse	Rough sawn boards, thickness sanding, and glue removal.
60	Coarse	Thickness sanding and glue removal.
80–100	Medium	Removing planer marks and initial finish sanding.
120–180	Fine	Finish sanding.

## NOTICE

**Sanding workpieces with high-resin content or with applied finishes can quickly contaminate the sandpaper beyond the point where it can be properly cleaned. This will produce poor sanding results. In this case, use a different workpiece, remove the applied finishes, or frequently clean/replace the sandpaper strip.**



## Replacement

Replacement sandpaper for the Model G0716 is available in 3" bulk rolls (see **Page 28** for options from Grizzly).

When fabricating a replacement sandpaper strip from bulk rolls, either use the existing strip as a template or refer to the dimensioning information in **Figure 17**.

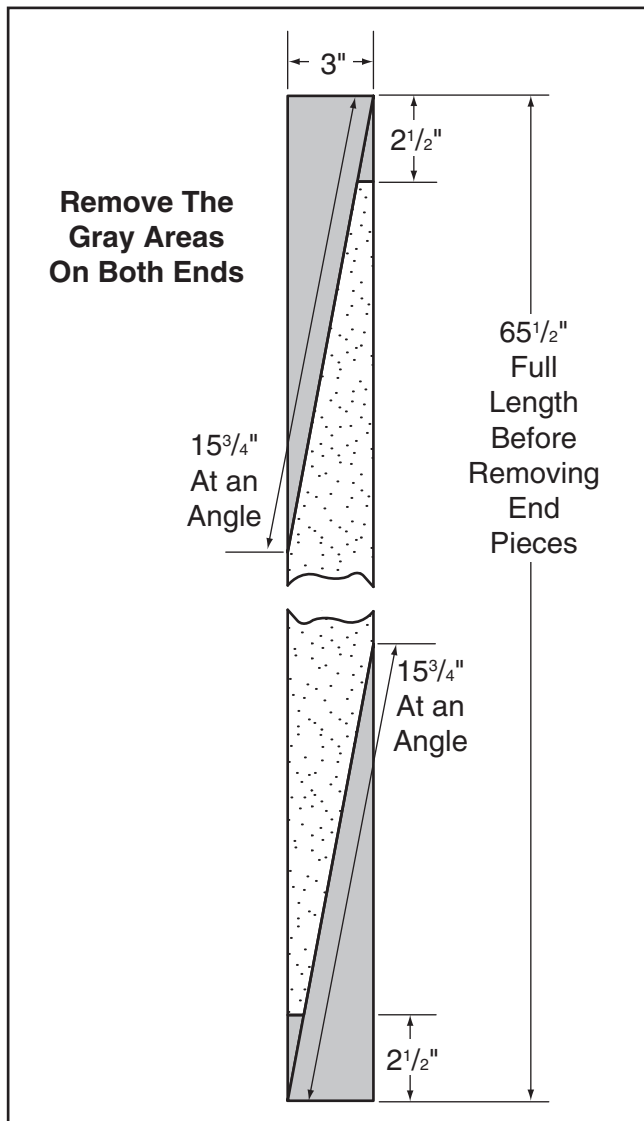

**Figure 17.** Replacement sandpaper dimensions.

**Tip:** To get two strips from a 10 ft. roll, cut the roll in the middle at an angled as shown here.

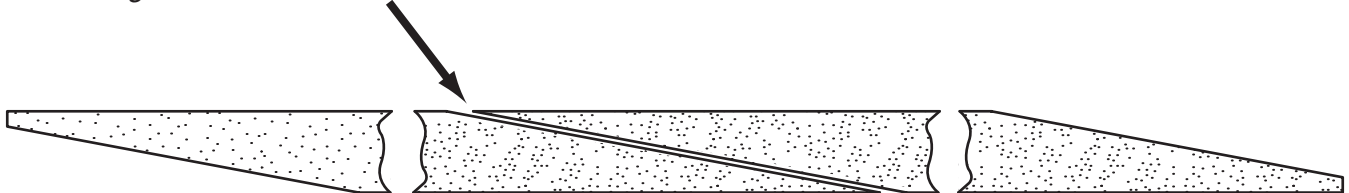

The proper installation of the sandpaper strip on the drum is essential to ensure good sanding results and prevent the sandpaper from coming loose or tearing during operation.

### Items Needed

**Qty**

Hex Wrench 5mm.....	1
Replacement Sandpaper Strip.....	1

### To replace the sandpaper strip:

1. DISCONNECT SANDER FROM POWER!
2. Remove the cap screw that secures the dust collection hood, then swing it up to gain access to the sanding drum.
3. Reach under the right lip of the drum and push the clamping device so that the jaw is aligned with the slot in the drum surface (see **Figure 18**).

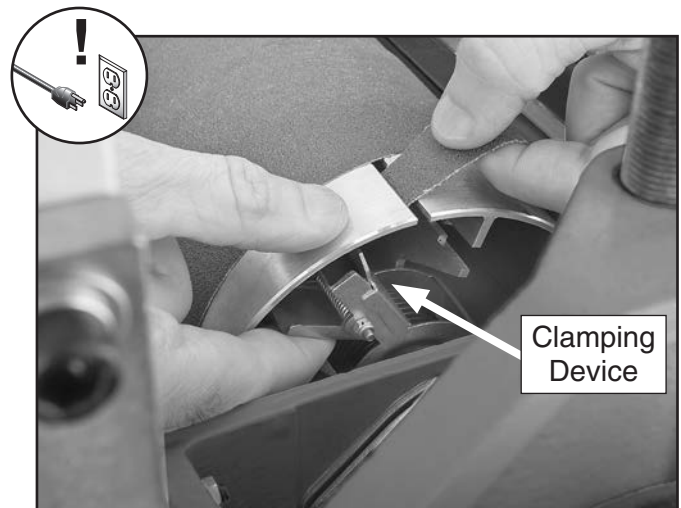

**Figure 18.** Aligning right clamping device jaw with the drum slot.





4. Unwind the sandpaper strip from the drum until you reach the clamping device on the left side (see **Figure 19**).



**Figure 19.** Releasing the clamping device on the left side of the drum.

5. Reach under the left drum lip and lift up on the clamping device to release its grip on the sandpaper, then remove the sandpaper.
6. Lift up on the same clamping device from **Step 5**, then insert the end of the replacement strip so that it fills as much of the slot as possible and is aligned with the left side of the slot.
7. Release the clamping device to hold the strip in place, then tug on it to make sure it is secure.

—If the strip comes loose when you tug on it with reasonable force, repeat **Steps 5–6** until it is properly secure.

## **⚠️ WARNING**

If the sandpaper strip comes loose during operation, it could cause the workpiece to bind and kickback at the operator, which could result in serious personal injury. Always make sure the sandpaper strip is properly installed and firmly secured by the clamping devices before connecting the sander to power.

8. While keeping reasonable tension on the strip with one hand, roll the drum away from you with the other hand to wrap the strip onto the drum (see **Figure 20**).

**Important:** When wrapping the strip onto the drum, a minimum  $\frac{1}{8}$ " gap between the edges may be necessary, but do not overlap. Additionally, make sure that the strip remains tight without any slack.



**Figure 20.** Wrapping sandpaper strip on the drum.

9. To secure the right end of the strip, move the clamping device forward by pressing against the spring lever until you can insert the holding pin between clamp and the spring lever, as shown in **Figure 21**.

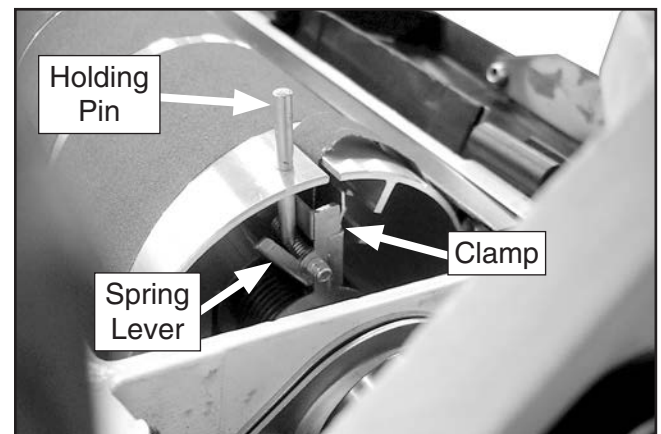
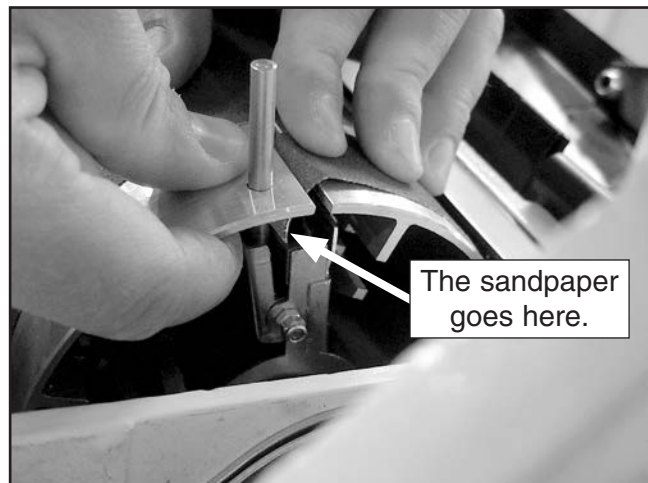

**Figure 21.** Holding pin inserted into the access hole (viewed from the right side of drum).



10. Press the spring lever toward the clamp to open it, then fully insert the end of the sandpaper strip between the two sides of the clamp, as shown in **Figure 22**.

**Important.** Make sure that the sandpaper end goes inside the clamp—not between the spring lever and the clamp.



**Figure 22.** Inserting the sandpaper end between the two sides of the clamp.

11. Release the spring lever—this will allow the clamp to grab the sandpaper end.
12. While maintaining pressure on the clamp with your finger as shown in **Figure 23**, remove the holding pin. Then, release the clamp—this will pull the sandpaper tight.

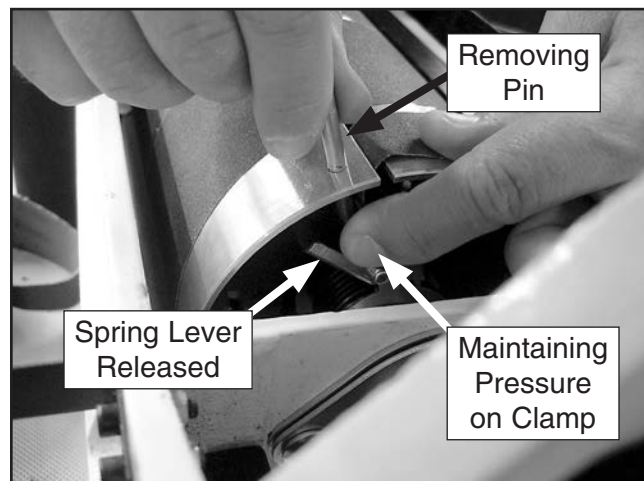

**Figure 23.** Properly securing the sandpaper end.

13. Check to make sure the sandpaper strip is tight against the drum, the edges are not more than  $\frac{1}{8}$ " apart, and they are not overlapped.

—If any of the conditions above are not true, repeat the installation procedure until they are.

14. Close and secure the dust collection hood with the cap screw before connecting the sander to power.



# Depth of Cut

The correct depth of cut when surface sanding with the Model G0716 depends on many variables, such as the hardness of the wood, the width of the workpiece, and the feed rate.

Generally, a  $\frac{1}{4}$  turn of the elevation handwheel ( $\frac{1}{32}$ " depth of cut) per pass is acceptable for coarser grits or softer woods. A  $\frac{1}{8}$  turn of the handwheel ( $\frac{1}{64}$ " depth of cut) is recommended for finer grits or harder woods. However, use your best judgement to produce good sanding results for your operation.

**Important:** *Keep in mind that, although the thickness of the workpiece is reduced during sanding, this process is not a replacement for thickness planing, which should be done with a planer or other acceptable tool/machine before beginning the sanding process.*

## NOTICE

**Taking an excessive depth of cut could cause the sanding motor to exceed the available power source amperage. In this case, the motor or power source circuit breaker will trip. If this should happen, disconnect the machine from power, allow the motor to cool, reset the circuit breaker, then take a smaller depth of cut.**

To adjust the depth of cut:

1. Loosen the elevation lock knob (see **Figure 24**).

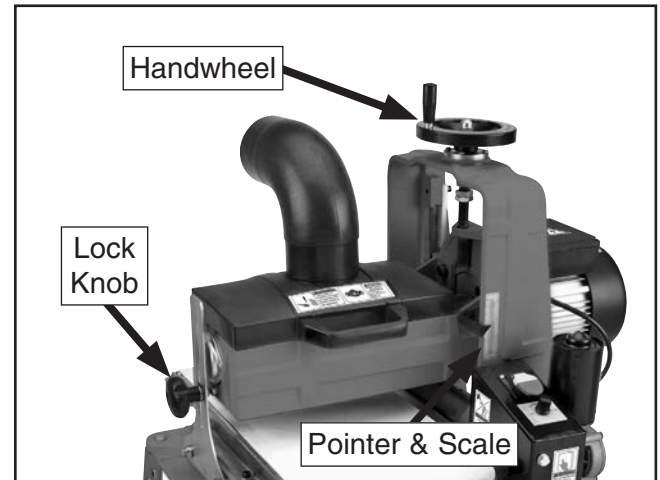

**Figure 24.** Elevation controls.

2. Rotate the elevation handwheel counter-clockwise to lower the sanding drum.

**Note:** A  $\frac{1}{4}$  turn of the handwheel equals  $\frac{1}{32}$ " depth of cut.

3. When you have set the proper depth of cut for your operation, firmly tighten the lock knob to secure the sanding drum in place above the workpiece.

## NOTICE

**It is imperative that the elevation lock knob is fully tightened before resuming the sanding process. Otherwise, the sanding drum will raise up under the pressure from the workpiece and will not evenly sand it.**



## Feed Rate

Setting the proper feed rate is a matter of experience and good judgement. When selecting the feed rate for the operation, consider variables such as the hardness and condition of the wood, the sandpaper grit being used, the finish desired, etc.

As a guideline, wide or hard workpieces, or using finer grit sandpaper will require a slower feed rate. The goal in setting the correct feed rate is to produce the desired results for the operation without burning the workpiece.

### **NOTICE**

**Using too fast of a feed rate may exceed the sanding motor capacity and trip the motor or power supply circuit breaker. Using too slow of a feed rate may burn the surface of the workpiece.**

To adjust the conveyor belt feed rate, rotate the conveyor variable feed rate dial shown in **Figure 25**.

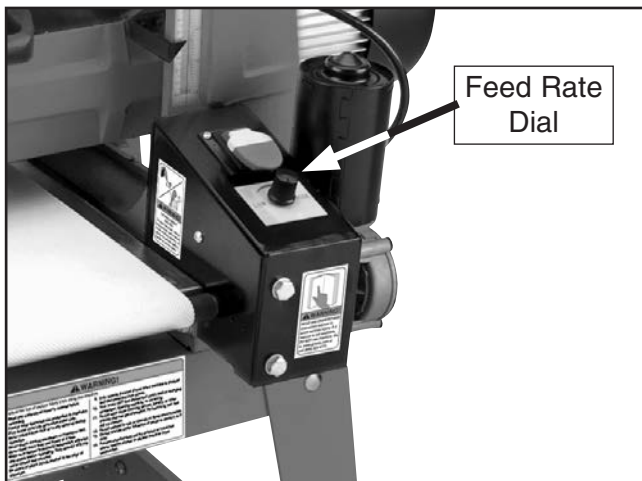

**Figure 25.** Location of the feed rate dial.

**Note:** The ON/OFF switch must be in the ON position to enable the conveyor motor to run.

## Sanding Tips

Follow these precautions to ensure safe sanding operation and quality results:

- Replace the sandpaper with a higher grit to achieve a finer finish (refer to **Sandpaper on Page 21**).
- When making multiple passes on the workpiece, do not lower the sanding drum more than  $\frac{1}{32}$ " or  $\frac{1}{4}$  turn of the elevation handwheel for any one pass.
- If possible, feed the workpiece at a  $60^\circ$  angle to the sanding drum. This will provide for more effective material removal, less loading and more even wear of the sandpaper, and lighter load on the motors. On the last finishing passes, feed the workpiece so that the majority of the grain is perpendicular to the sanding drum.
- Extend the life of the sandpaper by regularly using a PRO-STICK® sanding pad (refer to **Accessories on Page 28**).
- Reduce snipe when sanding more than one board of the same thickness by feeding them into the sander with the front end of the second board touching the back end of the first board.
- DO NOT edge sand boards. This can cause boards to kickback, causing serious personal injury. Edge sanding boards also can cause damage to the conveyor belt and sandpaper.
- When sanding workpieces with a bow or crown, place the high point up (prevents the workpiece from rocking) and take very light passes.



# Sanding Operation

---

## To surface sand a workpiece:

1. Make sure the sander is turned **OFF** and the sanding drum is completely stopped.
2. Make sure that the correct sandpaper grit is properly installed on the drum.
3. Inspect the workpiece and make sure it is acceptable for the sanding operation (refer to **Workpiece Inspection** on **Page 21** for details).
4. Place the workpiece flat on the conveyor belt and under the sanding drum.
5. Lower the sanding drum until it matches the greatest height of the workpiece.

**Note:** *Make this adjustment so that the first passes will take off just the high spots of the workpiece.*

6. Remove the workpiece from the conveyor belt, then turn the sander **ON** and adjust the conveyor feed rate so that it is correct for the operation.
7. Stand to the left of the conveyor belt to avoid the hazards of kickback, place it on the conveyor belt at the correct angle, then allow the belt to feed it under the sanding drum.

8. When the sanding drum has complete control of the workpiece, step to the rear of the sander, and maintain control and support of the workpiece as it leaves the sanding drum on its own.
9. Without changing the depth-of-cut setting, rotate the workpiece 180° horizontally and pass it through the sander again.

**Note:** *If fine thickness dimensioning or maintaining the same finishes on both sides of the workpiece is required for the operation, flip the workpiece over, lower the sanding drum the correct amount, and repeat **Steps 7–9**. Return the workpiece to its original side before continuing with the next step.*

10. Increase the depth of cut by the correct amount, then repeat **Steps 7–10** with progressively finer grits until you have produced the desired results.

**Note:** *Keep in mind that as the grit and desired finish change, you need to reduce the feed rate.*

11. When the sanding operation is complete, turn the sander **OFF**.



# SECTION 5: ACCESSORIES

## **⚠️ WARNING**

Some aftermarket accessories can be installed on this machine that could cause it to function improperly, increasing the risk of serious personal injury. To minimize this risk, only install accessories recommended for this machine by Grizzly.

## **NOTICE**

Refer to the newest copy of the Grizzly Catalog for other accessories available for this machine.

**Call 1-800-523-4777 To Order**

### **G1512—Pro-Stik® Sandpaper Cleaner Pad**

This crepe-rubber Sandpaper Cleaner quickly removes gum and grit from sandpaper strips without damage. Just run the cleaner through the sander several times along the length of the sanding drum until it is clean. Extend the life of your sandpaper with this innovative natural cleaner.



**Figure 26.** G1512 Pro-Stik® Belt Cleaner.

### **3" x 10 ft. Aluminum Oxide Sanding Rolls**

- G3071—60 Grit
- G3072—80 Grit
- G3073—100 Grit
- G3074—120 Grit
- G4400—150 Grit
- G4401—180 Grit
- G4402—220 Grit



**Figure 27.** 3" x 10 ft. sandpaper rolls.

- H2499—Small Half-Mask Respirator**
- H3631—Medium Half-Mask Respirator**
- H3632—Large Half-Mask Respirator**
- H3635—Cartridge Filter Pair P100**

Wood dust has been linked to nasal cancer and severe respiratory illnesses. If you work around dust everyday, a half-mask respirator can be a lifesaver. Also compatible with safety glasses!



**Figure 28.** Half-mask respirator with disposable cartridge filters.



# SECTION 6: MAINTENANCE

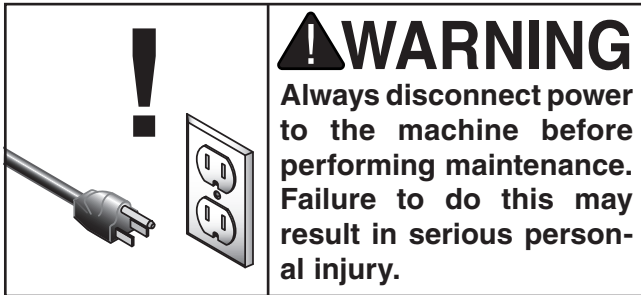

## Schedule

For optimum performance from your machine, follow this maintenance schedule and refer to any specific instructions given in this section.

### Daily Check

- Loose mounting bolts.
- Damaged, worn, or loaded sandpaper.
- Worn or damaged wires or switches.
- Worn or damaged conveyor belt.
- Any other unsafe condition.

## General Cleaning

Cleaning the Model G0716 is relatively easy. Vacuum excess wood chips and sawdust, and wipe off the remaining dust with a dry cloth. If any resin has built up on the sanding drum, remove the sandpaper strip and use a resin dissolving cleaner to remove the resin. Clean the conveyor belt with soapy water.

## Cleaning Sandpaper

When the sandpaper strip becomes loaded with built-up sawdust and gum, run a sandpaper cleaner pad through the machine several times along the full length of the sanding drum until the sandpaper is clean (see **Page 28** for an option from Grizzly).

## Lubrication

The bearings on the Model G0716 have been lubricated and sealed at the factory. No other care of these bearings is necessary unless they need replacement.

Periodically, depending upon usage, clean away and sawdust or grime from the elevation leadscrew and the sanding head slides (see **Figure 29**), then apply a small amount of dry lubricant, such as graphite. Move the sanding head through its full range of motion to distribute the lubricant.

**Note:** Do not use grease or oil lubricants that will attract and hold the sawdust.

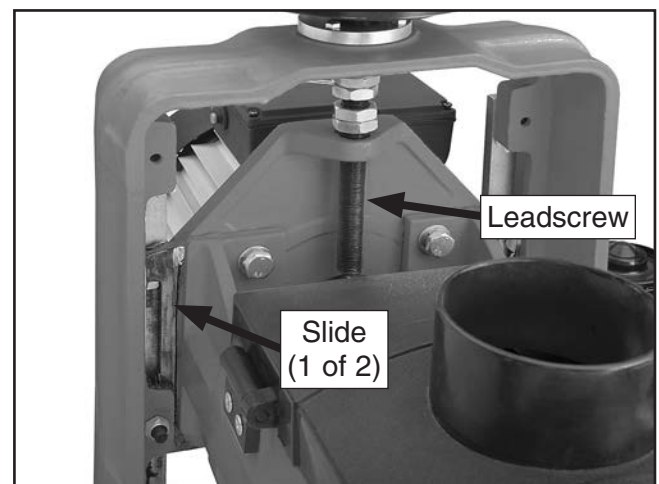

**Figure 29.** Location of lubrication points.



# SECTION 7: SERVICE

Review the troubleshooting and procedures in this section to fix or adjust your machine if a problem develops. If you need replacement parts or you are unsure of your repair skills, then feel free to call our Technical Support at (570) 546-9663.

## Troubleshooting



Symptom	Possible Cause	Possible Solution
Machine does not start or a breaker trips.	<ol style="list-style-type: none"> <li>1. Switch disabling key removed.</li> <li>2. Power source switched <b>OFF</b> or at fault.</li> <li>3. Plug/receptacle at fault; wired incorrectly.</li> <li>4. Start capacitor at fault.</li> <li>5. Motor connection wired incorrectly.</li> <li>6. Motor overloaded and its circuit breaker tripped.</li> <li>7. Power source circuit breaker tripped.</li> <li>8. Wiring open; has high resistance.</li> <li>9. ON/OFF switch at fault.</li> <li>10. Motor at fault.</li> </ol>	<ol style="list-style-type: none"> <li>1. Re-install switch disabling key.</li> <li>2. Ensure power source is <b>ON</b> and has correct voltage.</li> <li>3. Test for good contacts; correct the wiring.</li> <li>4. Test; replace if faulty.</li> <li>5. Correct motor wiring (see <b>Page 40</b>).</li> <li>6. Wait for motor to cool, then reduce depth of cut or feed rate.</li> <li>7. Ensure circuit size is correct (see <b>Page 9</b>); replace weak circuit breaker; reduce depth of cut or feed rate.</li> <li>8. Check and repair open or corroded wiring.</li> <li>9. Replace switch.</li> <li>10. Test; replace if faulty.</li> </ol>
Machine stalls or is overloaded.	<ol style="list-style-type: none"> <li>1. Workpiece material not suitable for machine.</li> <li>2. Depth of cut too much; feed rate too much.</li> <li>3. Dust collection ducting problem.</li> <li>4. Motor connection wired incorrectly.</li> <li>5. Power source not adequate.</li> </ol>	<ol style="list-style-type: none"> <li>1. Only sand natural wood products; ensure moisture content is below 20%.</li> <li>2. Reduce depth of cut; reduce feed rate.</li> <li>3. Clear blockages, seal leaks, use smooth wall duct, eliminate bends, close other branches.</li> <li>4. Correct motor wiring (see <b>Page 40</b>).</li> <li>5. Ensure circuit size is correct (see <b>Page 9</b>).</li> </ol>
Machine has excessive vibration or noisy operation.	<ol style="list-style-type: none"> <li>1. Sandpaper torn or not properly installed.</li> <li>2. Motor or component loose.</li> <li>3. Machine sits unevenly on floor.</li> <li>4. Motor fan rubbing on fan cover.</li> <li>5. Motor bearings at fault.</li> <li>6. Sanding drum bearings at fault.</li> </ol>	<ol style="list-style-type: none"> <li>1. Replace/re-install sandpaper (see <b>Page 21</b>).</li> <li>2. Inspect/replace damaged fasteners, and re-tighten with thread locking fluid.</li> <li>3. Move machine or shim under legs until it sits evenly.</li> <li>4. Fix/replace fan cover or fan.</li> <li>5. Test by rotating shaft by hand; rotational grinding or loose shaft requires bearing replacement.</li> <li>6. Replace bearings.</li> </ol>
Grit rubs off sandpaper easily.	<ol style="list-style-type: none"> <li>1. Sandpaper has been stored in an incorrect environment.</li> <li>2. Sandpaper has been folded or damaged.</li> </ol>	<ol style="list-style-type: none"> <li>1. Store sandpaper away from extreme dry/moist environment or hot temperatures.</li> <li>2. Store sandpaper rolled, not folded or bent.</li> </ol>





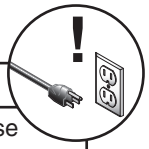

Symptom	Possible Cause	Possible Solution
Sandpaper clogs quickly.	<ol style="list-style-type: none"> <li>1. Sanding depth of cut too much or feed rate too slow.</li> <li>2. Workpiece has high moisture content or sap.</li> <li>3. Not using the correct grit sandpaper.</li> <li>4. Poor dust collection.</li> <li>5. Sandpaper loaded with sawdust and gum.</li> </ol>	<ol style="list-style-type: none"> <li>1. Reduce depth of cut or increase feed rate; use coarser grit sandpaper.</li> <li>2. Use different stock, or accept the characteristics of the stock and plan on cleaning/replacing sandpaper frequently; remove applied finishes before sanding.</li> <li>3. Use the correct grit sandpaper for the operation (see <b>Page 21</b>).</li> <li>4. Unclog ducts; close gates to improve suction; re-design dust collection system.</li> <li>5. Clean/replace sandpaper (see <b>Page 29</b>).</li> </ol>
Burn marks on workpiece.	<ol style="list-style-type: none"> <li>1. Using too fine of sanding grit for depth of cut.</li> <li>2. Sandpaper loaded with sawdust and gum.</li> <li>3. Feed rate too slow.</li> <li>4. Sanding strip overlapped.</li> </ol>	<ol style="list-style-type: none"> <li>1. Use coarser grit sandpaper or decrease depth of cut.</li> <li>2. Clean/replace sandpaper (see <b>Page 29</b>).</li> <li>3. Increase feed rate.</li> <li>4. Properly re-install sandpaper strip (see <b>Page 21</b>).</li> </ol>
Glazed workpiece surface after sanding.	<ol style="list-style-type: none"> <li>1. Sanding wet stock.</li> <li>2. Sanding stock with high amount of applied finishes.</li> </ol>	<ol style="list-style-type: none"> <li>1. Only sand stock that has moisture content below 20%.</li> <li>2. Use different stock, or accept the characteristics of the stock and plan on cleaning/replacing sandpaper frequently; remove applied finishes before sanding.</li> </ol>
Workpiece slips on conveyor.	<ol style="list-style-type: none"> <li>1. Conveyor belt dirty or worn.</li> <li>2. Pressure rollers not properly adjusted.</li> </ol>	<ol style="list-style-type: none"> <li>1. Clean/replace conveyor belt (see <b>Page 29</b>).</li> <li>2. Properly adjust pressure roller height (see <b>Page 36</b>).</li> </ol>
Uneven workpiece thickness from side to side.	<ol style="list-style-type: none"> <li>1. Elevation lock knob not tight and sanding drum is deflecting up.</li> <li>2. Conveyor belt not parallel to sanding drum.</li> <li>3. Gibs are too loose.</li> <li>4. Conveyor belt is worn.</li> </ol>	<ol style="list-style-type: none"> <li>1. Fully tighten elevation lock knob after setting the elevation.</li> <li>2. Properly align conveyor belt to sanding drum (see <b>Page 35</b>).</li> <li>3. Properly adjust the gibs (see <b>Page 34</b>).</li> <li>4. Replace conveyor belt (see <b>Page 38</b>).</li> </ol>
Conveyor belt slips or does not track correctly.	<ol style="list-style-type: none"> <li>1. Belt tension not properly adjusted.</li> <li>2. Belt tracking not properly adjusted.</li> <li>3. Conveyor belt is worn.</li> </ol>	<ol style="list-style-type: none"> <li>1. Properly adjust belt tension (see <b>Page 33</b>).</li> <li>2. Properly adjust belt tracking (see <b>Page 33</b>).</li> <li>3. Replace conveyor belt (see <b>Page 38</b>).</li> </ol>
Elevation handwheel hard to rotate.	<ol style="list-style-type: none"> <li>1. Elevation lock knob tight.</li> <li>2. Leadscrew and nut clogged with sawdust.</li> <li>3. Gibs are too tight.</li> </ol>	<ol style="list-style-type: none"> <li>1. Loosen the elevation lock knob.</li> <li>2. Clean and lubricate the leadscrew and nut (see <b>Page 29</b>).</li> <li>3. Properly adjust the gibs (see <b>Page 34</b>).</li> </ol>
Sandpaper strip comes off drum or is loose.	<ol style="list-style-type: none"> <li>1. Sandpaper strip not properly wrapped onto drum.</li> <li>2. Sandpaper strip not cut to the correct dimensions.</li> <li>3. Slack in sanding strip.</li> <li>4. Torn or damaged sandpaper strip.</li> </ol>	<ol style="list-style-type: none"> <li>1. Properly re-install sandpaper strip (see <b>Page 21</b>).</li> <li>2. Only use sandpaper strips that are cut to the correct dimensions (see <b>Page 21</b>).</li> <li>3. Properly wrap sandpaper strip and make sure the right end is fully inserted into the drum slot (see <b>Page 21</b>).</li> <li>4. Replace sandpaper (see <b>Page 21</b>).</li> </ol>



Symptom	Possible Cause	Possible Solution
Ripples or lines in workpiece.	<ol style="list-style-type: none"> <li>1. Uneven feed rate.</li> <li>2. Sanding drum deflecting from workpiece.</li> </ol>	<ol style="list-style-type: none"> <li>1. Maintain an even feed rate through the entire sanding operation.</li> <li>2. Make sure the elevation lock knob is tight.</li> </ol>
Snipe marks in workpiece.	<ol style="list-style-type: none"> <li>1. Improper pressure roller tension.</li> <li>2. Workpiece too long to be supported without additional help.</li> </ol>	<ol style="list-style-type: none"> <li>1. Evenly adjust pressure roller tension (see <b>Page 36</b>).</li> <li>2. Use roller stands or tables on the infeed and outfeed ends of the conveyor to keep the workpiece from bending.</li> </ol>



# Conveyor Belt Tension & Tracking

The conveyor belt tension and tracking must be properly adjusted to ensure that the workpiece correctly and safely passes underneath the sanding drum and that the conveyor belt does not become damaged during operation.

If the conveyor belt slips on the rollers then the belt tension needs to be increased.

If the conveyor belt moves to one side or the other when it is running, then the belt tracking needs to be adjusted.

Tools Needed	Qty
Phillips Screwdriver #2 .....	1
Open-End Wrench 10mm.....	1

## Belt Tension

1. DISCONNECT SANDER FROM POWER!
2. Make sure the conveyor belt is centered on the rollers.

—If it is not, release the belt tension equally on both sides of the belt. This is done by holding the hex nut still (see **Figure 30**) while rotating the Phillips head screw counterclockwise until you can move the belt from side-to-side with your hand. Then, center the belt on the rollers.

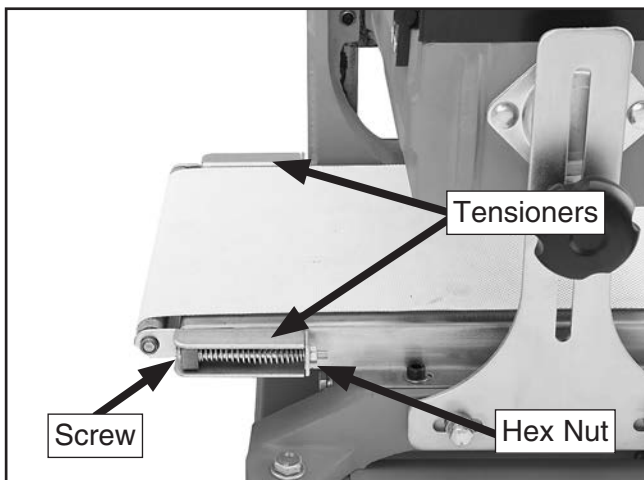

**Figure 30.** Conveyor belt tensioners.

3. As a starting point, make sure that the ends of both tensioning screws extend evenly approximately  $\frac{1}{4}$ " beyond the hex nut, as shown in **Figure 31**.

—If the belt slips during operation, rotate the screws clockwise in small amounts until the belt no longer slips on the rollers.

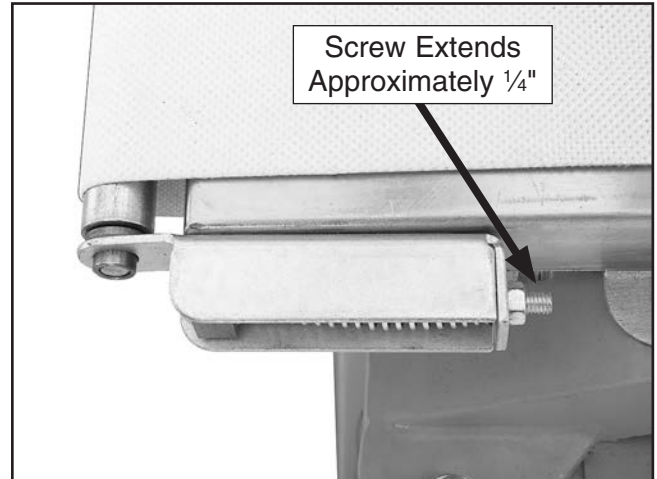

**Figure 317.** Tensioning screw extending approximately  $\frac{1}{4}$ " beyond hex nut.

## Belt Tracking

1. Run the conveyor belt at high speed and note if it tracks to one side or the other—this may take a couple of minutes to show up.

**Note:** To avoid damaging the belt, do not allow the belt to track off the rollers.

—If the conveyor belt does not track to one side or the other, no further adjustments are necessary.

**Note:** In the next step, you may have to wait for several minutes to notice a change in tracking.

2. Rotate the tensioner screw clockwise on the side the belt is tracking toward until the belt moves to the center of the rollers, then back off the screw until it stops tracking to the opposite side.
3. Allow the belt to run for several minutes to make sure it is tracking properly. If necessary, repeat this procedure until the belt is properly tracking.



# Gib Adjustment

The gibs apply pressure to the slides of the sanding head (see **Figures 32–33**). This allows the sanding head assembly to accurately move up and down when using the elevation handwheel.

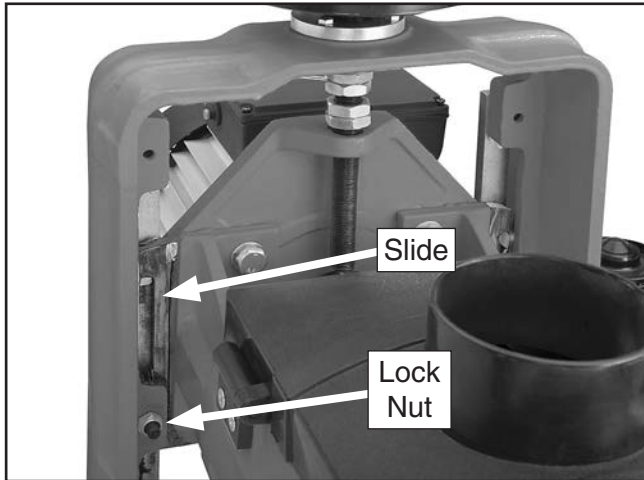

**Figure 32.** Location of rear slide and lock nut.

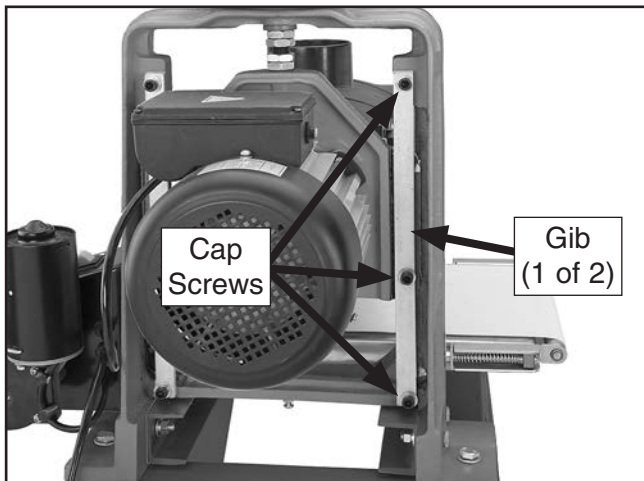

**Figure 33.** Location of rear gib and cap screws.

If the gibs are too loose, the sanding drum will deflect up during operation, which will result in poor sanding results.

If the gibs are too tight, it will be difficult to adjust the sanding drum elevation, which will cause excessive wear on the parts of the elevation system.

## To adjust the gibs:

1. DISCONNECT SANDER FROM POWER!
2. Loosen the center lock nut on both gibs (see **Figure 32**).
3. Adjust each of the six gib cap screws in or out in small, equal amounts, then rotate the elevation handwheel to test the sanding head movement.

**Note:** Tighten the cap screws to increase gib pressure.

4. Repeat **Step 3** until you are satisfied with the sanding head movement, then re-tighten both lock nuts.



# Conveyor Belt to Drum Alignment

To ensure good sanding results, the conveyor belt and sanding drum must be parallel with each other from side to side (see the illustration in **Figure 34**). Otherwise, more material will be removed from one side of the workpiece than the other.

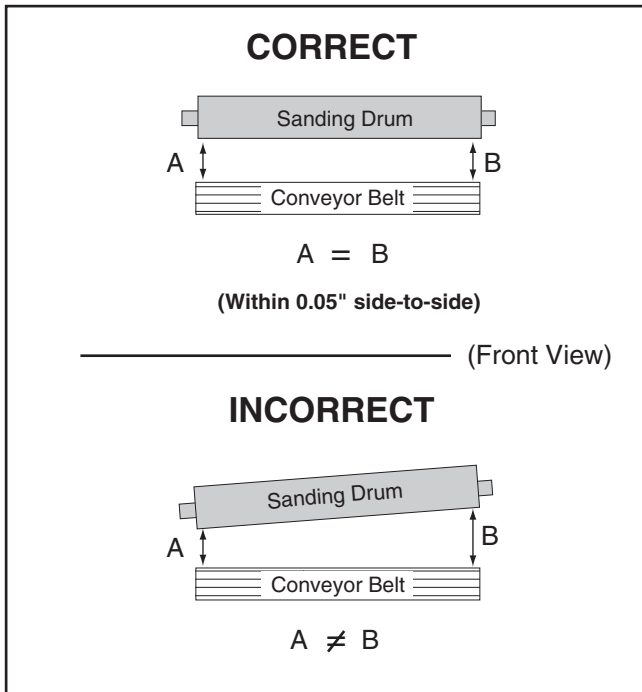

**Figure 34.** Illustration of conveyor belt to sanding drum parallelism.

The goal of this procedure is to bring the conveyor belt and sanding drum parallelism within 0.05" difference from side to side.

Items Needed	Qty
Board 2" Thick x 8–10" Wide .....	1
Hex Wrench 6mm.....	1
Metal Shim Material.....	As Needed

## To check and adjust the conveyor belt to sanding drum parallelism:

1. Make sure the gibs are properly adjusted.
2. Plane the board so that the thickness on each side of it is equal.

3. Take several light cuts through the sander without rotating or flipping the board.
4. Make measurements at "A" and "B" as indicated in **Figure 34**.

—If measurement "A" is less than "B", loosen or remove the cap screws on the *right* conveyor support (see **Figure 35**) and shim between the support and frame to compensate for the difference between "A" and "B".

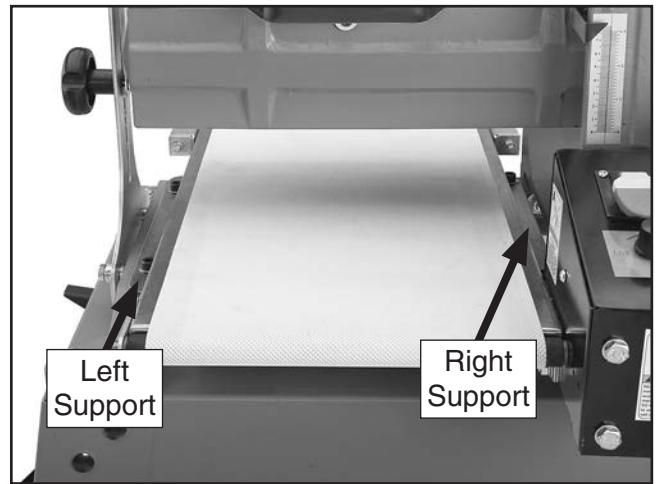

**Figure 35.** Conveyor supports.

—If measurement "B" is less than "A", loosen or remove the cap screws on the *left* conveyor support and shim between the support and frame to compensate for the difference.

5. Repeat **Steps 2–4** to verify the adjustment. If necessary, repeat this procedure until the conveyor belt and sanding drum parallelism is within 0.05" difference from side to side.



# Pressure Roller Adjustment

The height of the pressure rollers (see **Figure 36**) is set slightly below the bottom of the sanding drum to keep the workpiece firmly against the conveyor belt as it passes through the sander, preventing workpiece kickback.

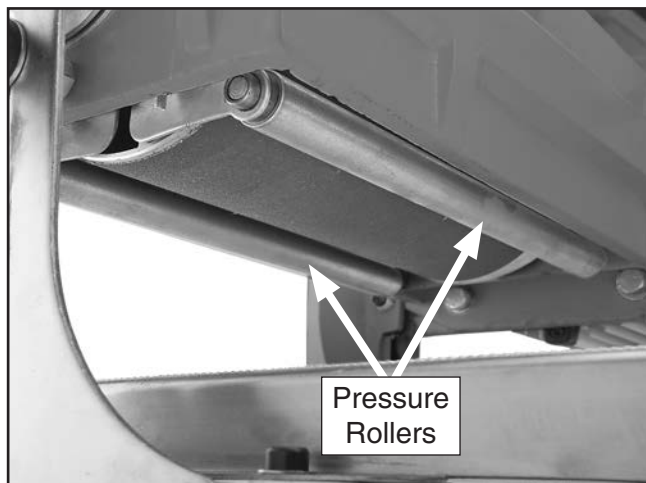

**Figure 36.** Location of the pressure rollers.

The pressure these rollers exert on the workpiece as it passes underneath the sanding head is controlled by compression springs and adjustment screws (see **Figure 37**).

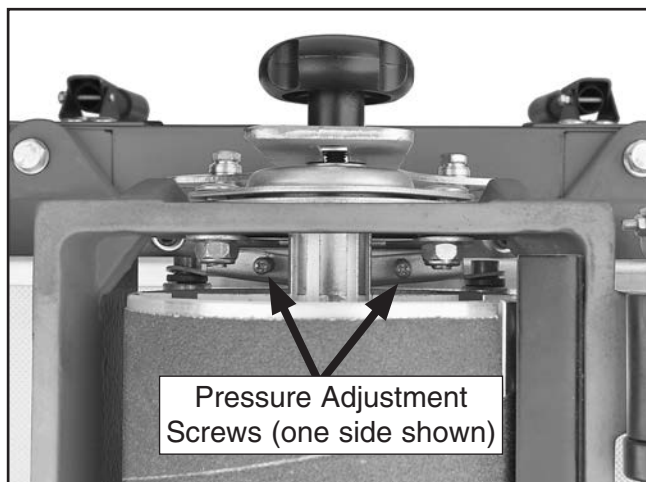

**Figure 37.** Location of the pressure roller adjustment screws.

Proper pressure on the workpiece helps avoid kickback and keeps the workpiece from slipping. However, as pressure increases on the workpiece from the rear pressure roller, snipe also increases. In this case, decrease the pressure on the rear roller.

If you choose to increase or decrease the pressure that these rollers exert on the workpiece, perform the following procedure.

<b>Tool Needed</b>	<b>Qty</b>
Hex Wrench 5mm.....	1
Phillips Screwdriver #2 .....	1

### To adjust the pressure rollers:

1. DISCONNECT SANDER FROM POWER!
2. Remove the cap screw that secures the dust collection hood, then lift the hood up to gain access to the pressure roller adjustment screws.
3. To increase the pressure exerted by the rollers, tighten all four screws in small, equal amounts, then test the pressure of the rollers by pressing up on them.

Conversely, loosen the adjustment screws to lessen the pressure.

4. Test your adjustments by sanding a scrap workpiece.

—If the workpiece tends to kickback, reduce the pressure by rotating the screws counterclockwise one turn, then perform the test again.

—If the workpiece slips on the conveyor belt, increase the pressure by rotating the screws clockwise one turn, then perform the test again.



# Adjusting Elevation Stop

A Phillips head screw that protrudes through the bottom of the frame acts as a stop to prevent the sanding drum from making contact with the conveyor belt when adjusting the height (see **Figure 38**).

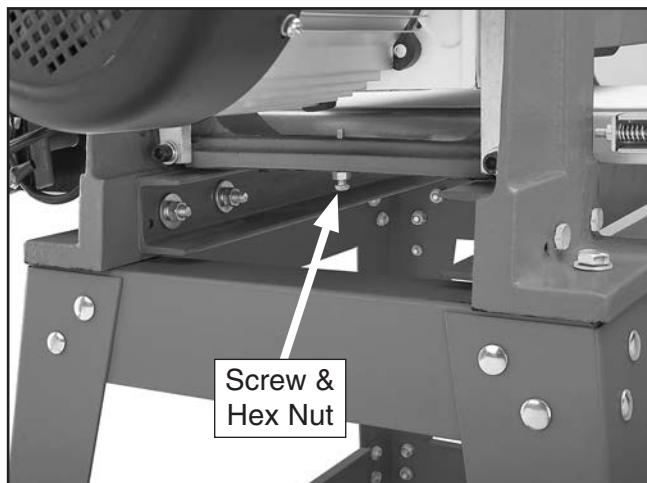

**Figure 38.** Location of the elevation stop.

The setting of the elevation stop screw was correctly set at the factory. However, if it is necessary to re-adjust the stop screw, perform this procedure.

<b>Tools Needed</b>	<b>Qty</b>
Wrench 10mm .....	1
Phillips Screwdriver #2 .....	1

## To adjust the elevation stop screw:

1. Make sure the conveyor belt is properly tensioned (refer to **Conveyor Belt Tension & Tracking** on **Page 33** for detailed instructions).
2. **DISCONNECT SANDER FROM POWER!**
3. Raise the sanding drum all the way up.
4. Loosen the hex nut on the stop screw, then adjust the height of the screw that protrudes above the frame to be no less than  $\frac{1}{4}$ ".
5. Re-tighten the hex nut, then lower the sanding drum until the stop screw contacts the motor mount frame.
6. Verify that the sanding drum is at least  $\frac{3}{16}$ " above the surface of the conveyor belt.  
  
—If the sanding drum is not at least  $\frac{3}{16}$ " above the conveyor belt, repeat this procedure until it is.



# Conveyor Belt Replacement

If the conveyor belt becomes excessively worn or damaged, it can easily be replaced. Contact Grizzly Customer Support at 1-800-523-4777 to obtain a replacement belt (Part No. P0706101).

Items Needed	Qty
Phillips Screwdriver #2 .....	1
Open-End Wrench 10mm.....	1
Wrench or Socket 13mm.....	1
Hex Wrench 6mm.....	1
Replacement Conveyor Belt.....	1

## To replace the conveyor belt:

1. DISCONNECT SANDER FROM POWER!
2. Fully release the belt tension (see **Conveyor Belt Tension & Tracking** on **Page 33** for detailed instructions).

**Note:** *In the next step, take care to keep the spacers and washers on the hex bolts in the same configuration for re-installation.*

3. Remove the knob and flat washer from the top of the sanding head support (see **Figure 39**), remove the hex bolts, spacers, and washers from the bottom of the support, then remove the support.

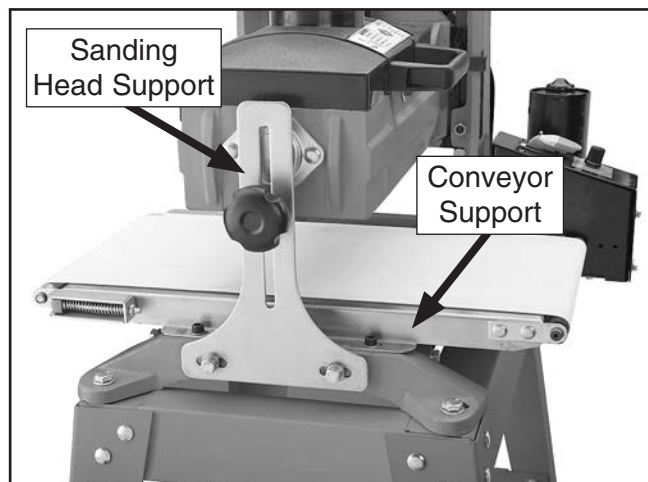

**Figure 39.** Location of sanding head and conveyor supports.

4. Remove the two cap screws and flat washers from the conveyor support (see **Figure 39**).
5. Lift the conveyor support up slightly and slip the conveyor belt off, as shown in **Figure 40**.



**Figure 40.** Removing the conveyor belt.

6. After sliding the replacement belt on, replace the conveyor support cap screws and flat washers, then re-install the sanding head support with the fasteners you removed in **Step 3**.
7. Properly tension the conveyor belt before connecting the sander to power (see **Conveyor Belt Tension & Tracking** on **Page 33** for detailed instructions).





# SECTION 8: WIRING

These pages are current at the time of printing. However, in the spirit of improvement, we may make changes to the electrical systems of future machines. Compare the manufacture date of your machine to the one stated in this manual, and study this section carefully.

If there are differences between your machine and what is shown in this section, call Technical Support at (570) 546-9663 for assistance BEFORE making any changes to the wiring on your machine. An updated wiring diagram may be available. **Note:** *Please gather the serial number and manufacture date of your machine before calling. This information can be found on the main machine label.*

## WARNING

### Wiring Safety Instructions

**SHOCK HAZARD.** Working on wiring that is connected to a power source is extremely dangerous. Touching electrified parts will result in personal injury including but not limited to severe burns, electrocution, or death. Disconnect the power from the machine before servicing electrical components!

**MODIFICATIONS.** Modifying the wiring beyond what is shown in the diagram may lead to unpredictable results, including serious injury or fire. This includes the installation of unapproved after-market parts.

**WIRE CONNECTIONS.** All connections must be tight to prevent wires from loosening during machine operation. Double-check all wires disconnected or connected during any wiring task to ensure tight connections.

**CIRCUIT REQUIREMENTS.** You MUST follow the requirements at the beginning of this manual when connecting your machine to a power source.

**WIRE/COMPONENT DAMAGE.** Damaged wires or components increase the risk of serious personal injury, fire, or machine damage. If you notice that any wires or components are damaged while performing a wiring task, replace those wires or components.

**MOTOR WIRING.** The motor wiring shown in these diagrams is current at the time of printing but may not match your machine. If you find this to be the case, use the wiring diagram inside the motor junction box.















**CAPACITORS/INVERTERS.** Some capacitors and power inverters store an electrical charge for up to 10 minutes after being disconnected from the power source. To reduce the risk of being shocked, wait at least this long before working on capacitors.

**EXPERIENCING DIFFICULTIES.** If you are experiencing difficulties understanding the information included in this section, contact our Technical Support at (570) 546-9663.

#### NOTICE

The photos and diagrams included in this section are best viewed in color. You can view these pages in color at [www.grizzly.com](http://www.grizzly.com).

#### COLOR KEY

BLACK		BLUE		YELLOW		LIGHT BLUE	
WHITE		BROWN		YELLOW GREEN		BLUE WHITE	
GREEN		GRAY		PURPLE		TURQUOISE	
RED		ORANGE		PINK			



# G0716 Wiring Diagram



Figure 41. Sanding motor wiring.

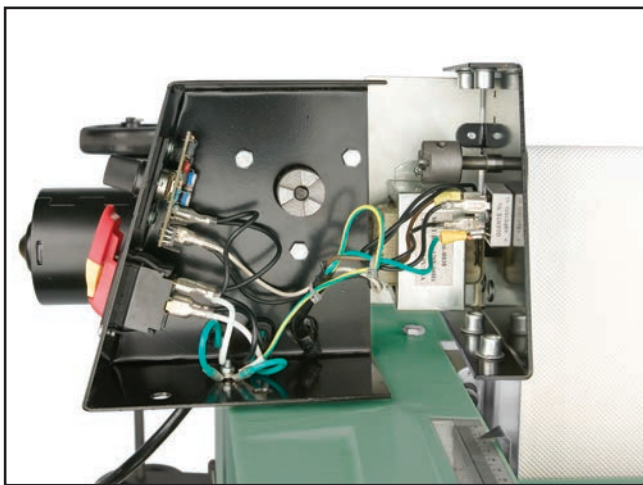
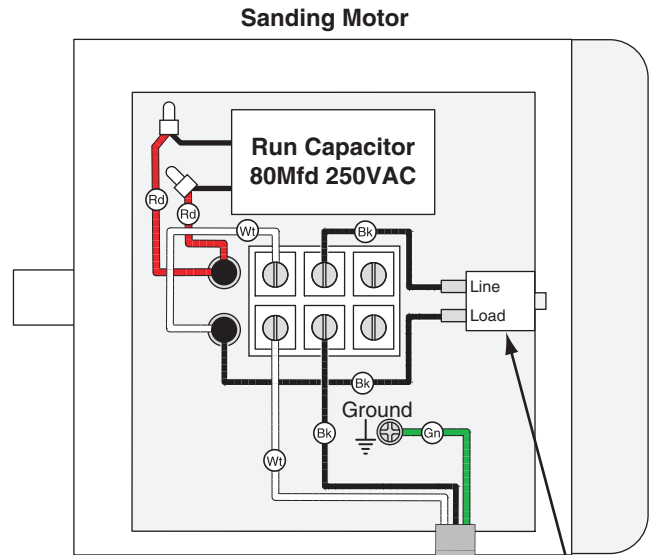
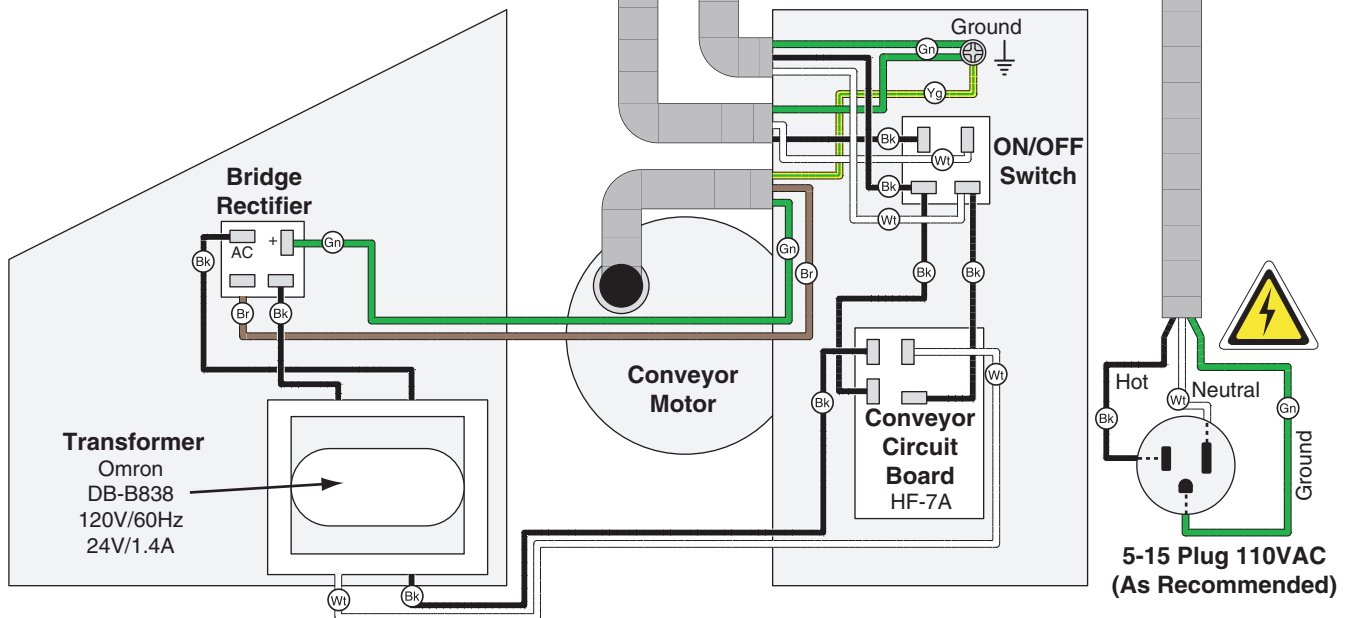

Figure 42. Switch wiring.



Thermal Overload Circuit Breaker



# SECTION 9: PARTS

## Stand

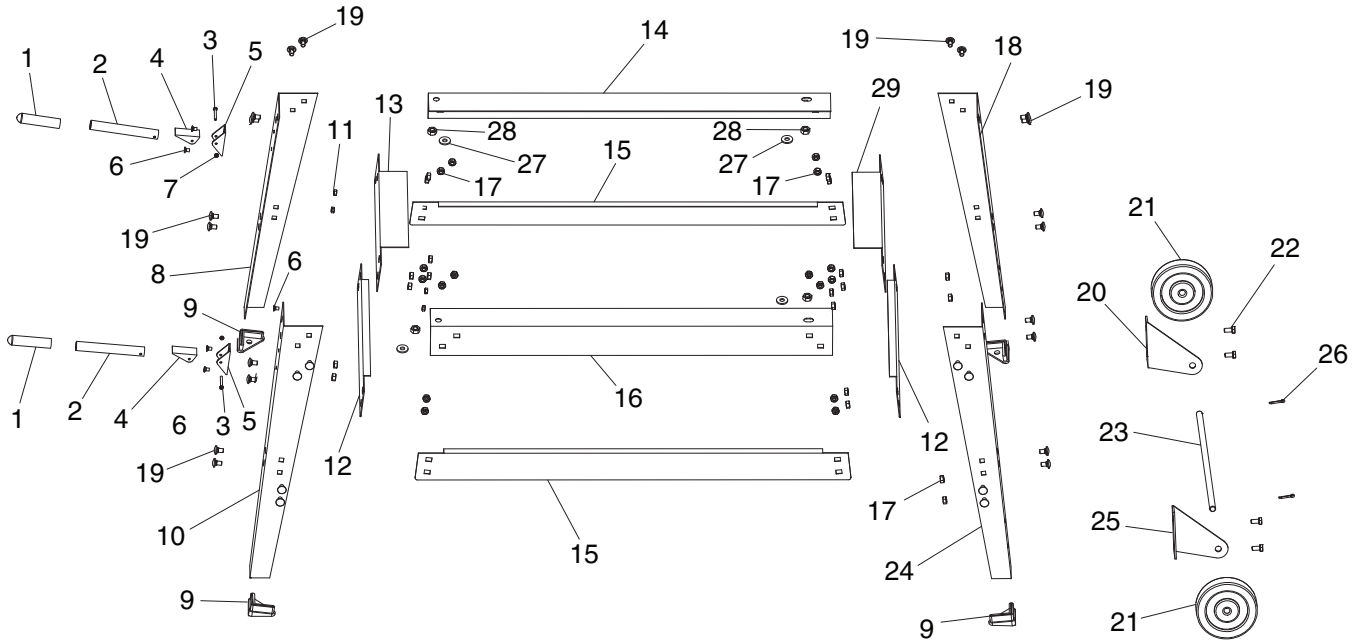

REF	PART #	DESCRIPTION
1	P0716001	HANDLE GRIP
2	P0716002	HANDLE
3	P0716003	PHLP HD SCR M4-.7 X 35
4	P0716004	HANDLE BRACKET
5	P0716005	HANDLE BASE
6	P0716006	FLAT HD SCR M6-1 X 10
7	P0716007	HEX NUT M4-.7
8	P0716008	LEFT FRONT STAND LEG
9	P0716009	LEG FOOT PAD
10	P0716010	RIGHT FRONT STAND LEG
11	P0716011	LOCK NUT M6-1
12	P0716012	SHORT BOTTOM BRACE
13	P0716013	FRONT SHORT TOP BRACE
14	P0716014	LEFT LONG TOP BRACE
15	P0716015	LONG BOTTOM BRACE

REF	PART #	DESCRIPTION
16	P0716016	RIGHT LONG TOP BRACE
17	P0716017	LOCK NUT M8-1.25
18	P0716018	LEFT REAR STAND LEG
19	P0716019	CARRIAGE BOLT M8-1.25 X 12
20	P0716020	LEFT WHEEL MOUNTING BRACKET
21	P0716021	WHEEL 5"
22	P0716022	HEX BOLT M8-1.25 X 16
23	P0716023	WHEEL AXLE
24	P0716024	RIGHT REAR STAND LEG
25	P0716025	RIGHT WHEEL MOUNTING BRACKET
26	P0716026	COTTER PIN 4 X 20
27	P0716027	FLAT WASHER 10MM
28	P0716028	LOCK NUT M10-1.5
29	P0716029	REAR SHORT TOP BRACE



# Conveyor

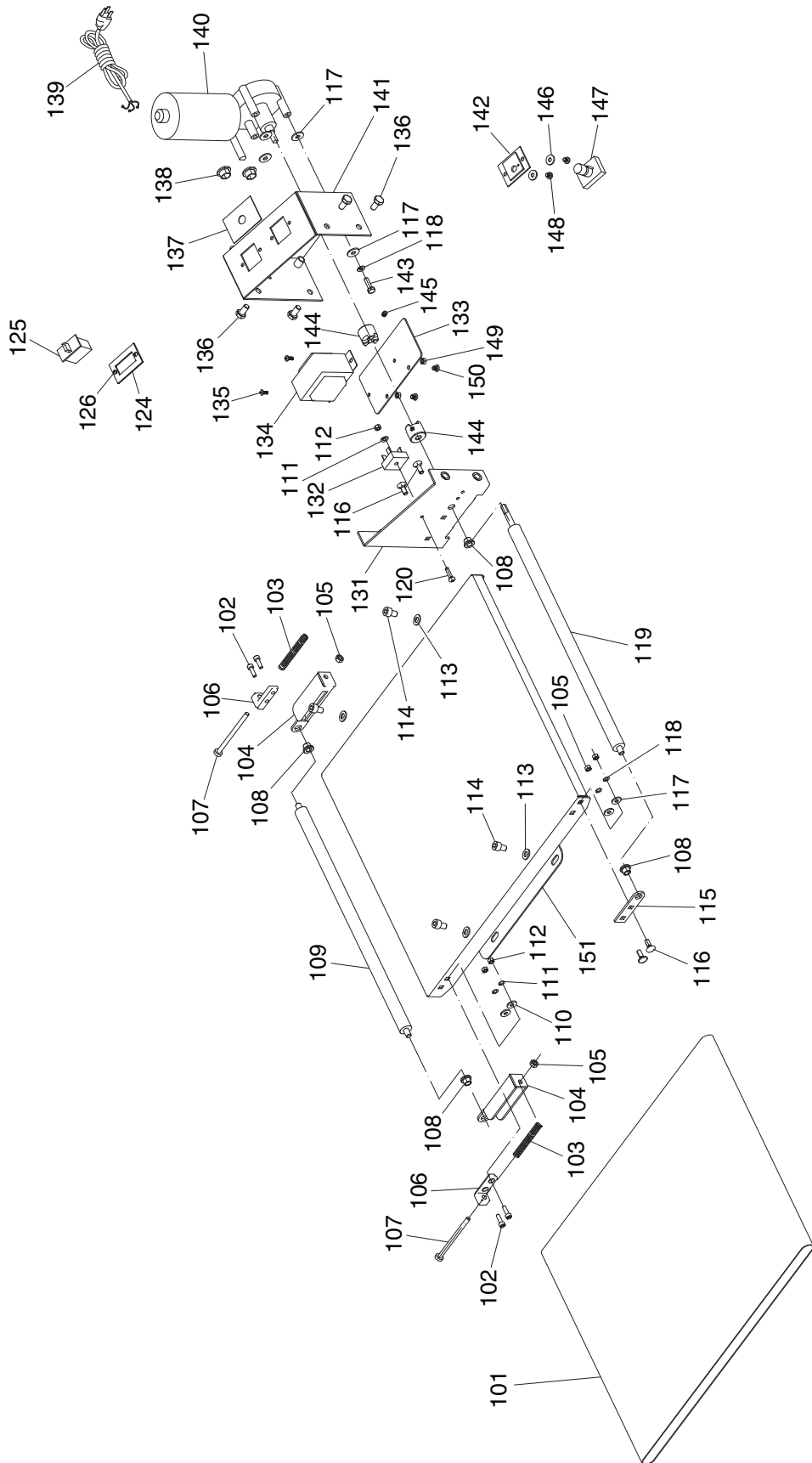

# Conveyor Parts List

REF	PART #	DESCRIPTION
101	P0716101	CONVEYOR BELT
102	P0716102	CAP SCREW M5-.8 X 16
103	P0716103	COMPRESSION SPRING
104	P0716104	OUTFEED ADJUSTABLE ROLLER BRACKET
105	P0716105	HEX NUT M6-1
106	P0716106	ADJUSTABLE SLIDE
107	P0716107	PHLP HD SCR M6-1 X 90
108	P0716108	FEED ROLLER BUSHING
109	P0716109	OUTFEED ROLLER
110	P0716110	FLAT WASHER 5MM
111	P0716111	LOCK WASHER 5MM
112	P0716112	HEX NUT M5-.8
113	P0716113	FLAT WASHER 8MM
114	P0716114	CAP SCREW M8-1.25 X 12
115	P0716115	INFEED ROLLER BRACKET
116	P0716116	CARRIAGE BOLT M6-1 X 16
117	P0716117	FLAT WASHER 6MM
118	P0716118	LOCK WASHER 6MM
119	P0716119	INFEED ROLLER
120	P0716120	PHLP HD SCR M5-.8 X 20
124	P0716124	SWITCH COVER
125	P0716125	GRIZZLY SAFETY ON/OFF SWITCH

REF	PART #	DESCRIPTION
126	P0716126	PHLP HD SCR M4-.7 X 12
131	P0716131	SWITCH HOUSING BRACKET
132	P0716132	TERMINAL BLOCK 4P
133	P0716133	SWITCH HOUSING PLATE
134	P0716134	TRANSFORMER OMRON HF-7A 24/120V
135	P0716135	PHLP HD SCR M4-.7 X 10
136	P0716136	HEX BOLT M8-1.25 X 16
137	P0716137	INSULATION PLATE
138	P0716138	STRAIN RELIEF 1/2" SNAP-IN
139	P0716139	POWER CORD 14G 3C 10' 5-15
140	P0716140	CONVEYOR MOTOR 24VDC
141	P0716141	SWITCH HOUSING
142	P0716142	INSULATION PAD
143	P0716143	HEX BOLT M6-1 X 20
144	P0716144	CONVEYOR CLUTCH
145	P0716145	FLAT WASHER 4MM
146	P0716146	FLAT WASHER 5MM
147	P0716147	VS FEED DIAL HF-7A 071015
148	P0716148	PHLP HD SCR M5-.8 X 6
149	P0716149	HEX NUT M4-.7
150	P0716150	PHLP HD SCR M5-.8 X 10
151	P0716151	CONVEYOR PLATEN





# Main Parts List

REF	PART #	DESCRIPTION
201	P0716201	CLUTCH DAMPER
202	P0716202	HEX BOLT M8-1.25 X 30
203	P0716203	DUST HOOD
204	P0716204	DUST CONNECTOR 90 DEG 4"
205	P0716205	LOCK NUT M8-1.25
206	P0716206	LOCKING PLATE
207	P0716207	DUST HOOD HANDLE
208	P0716208	CAP SCREW M8-1.25 X 25
209	P0716209	FLAT HD SCR M4-.7 X 8
210	P0716210	LEFT SANDPAPER CLAMP
211	P0716211	LOCK WASHER 4MM
212	P0716212	HEX NUT M4-.7
213V2	P0716213V2	SANDING DRUM V2.08.10
214	P0716214	SANDPAPER 3"W X 63" 80GRIT
215	P0716215	TORSION SPRING
216	P0716216	EXT RETAINING RING 28MM
217	P0716217	RIGHT SANDPAPER CLAMP
218	P0716218	INTERNAL DRUM GUARD
219	P0716219	FLAT HD SCR M6-1 X 30
220	P0716220	DUST HOOD HINGE
221	P0716221	CARRIAGE BOLT M8-1.25 X 25
222	P0716222	OUTSIDE BEARING RETAINER
223	P0716223	BALL BEARING 6205-2RS
224	P0716224	INTERNAL BEARING RETAINER
225	P0716225	DRUM HOUSING
226	P0716226	FLAT WASHER 8MM
227	P0716227	HEX NUT M8-1.25
228	P0716228	HEX NUT M6-1
229	P0716229	POINTER
230	P0716230	CAP SCREW M6-1 X 14
232	P0716232	FLAT WASHER 6MM
233	P0716233	AUXILIARY GUARD
234	P0716234	PHLP HD SCR M5-.8 X 16
235	P0716235	DRUM CLUTCH
236	P0716236	SET SCREW M6-1 X 8
237	P0716237	CAP SCREW M4-.7 X 20
238	P0716238	FLAT WASHER 4MM
239	P0716239	FLAT WASHER 5MM
240	P0716240	LOCK WASHER 5MM
241	P0716241	PHLP HD SCR M4-.7 X 30
242	P0716242	COMPRESSION SPRING
243	P0716243	PRESSURE ROLLER BRACKET
244	P0716244	RIGHT BRACKET SUPPORT
245	P0716245	LEFT BRACKET SUPPORT
246	P0716246	LOCK NUT M4-.7
247	P0716247	PRESSURE ROLLER BUSHING
248	P0716248	PRESSURE ROLLER
249	P0716249	ACORN NUT M12-1.75

REF	PART #	DESCRIPTION
250	P0716250	FLAT WASHER 12MM
251	P0716251	ELEVATION ROTATION LABEL
252	P0716252	HANDWHEEL ASSEMBLY
253	P0716253	ELEVATION LEADSCREW
254	P0716254	KEY 5 X 5 X 16
255	P0716255	HEX BOLT M5-.8 X 16
256	P0716256	SHAFT END CAP
257	P0716257	STEEL BALL
258	P0716258	BEARING RACE
259	P0716259	FRAME CASTING
260	P0716260	LEADSCREW FLAT WASHER 16MM
261	P0716261	THIN NUT M16-1.5
262	P0716262	PHLP HD SCR M6-1 X 35
263	P0716263	HEX BOLT M8-1.25 X 40
264	P0716264	ROLL PIN 6 X 26
265	P0716265	ELEVATION SCALE
266	P0716266	OUTFEED ROLLER SUPPORT
267	P0716267	INFEED ROLLER SUPPORT
268	P0716268	LOCK WASHER 8MM
269	P0716269	HEX BOLT M8-1.25 X 25
270	P0716270	CONVEYOR SUPPORT
271	P0716271	THREADED STUD M8-1.25 X 80
272	P0716272	DRUM HOUSING SUPPORT
273	P0716273	FENDER WASHER 8MM
274	P0716274	KNOB M8-1.25
275	P0716275	HEX BOLT M10-1.5 X 30
276	P0716276	LOCK WASHER 10MM
277	P0716277	FLAT WASHER 10MM
278	P0716278	MOTOR MOUNT
279	P0716279	GIB
280	P0716280	CAP SCREW M8-1.25 X 30
281V2	P0716281V2	MOTOR 1HP 110V 1-PH V2.02.18
281V2-1	P0716281V2-1	MOTOR FAN COVER
281V2-2	P0716281V2-2	MOTOR FAN
281V2-3	P0716281V2-3	MOTOR JUNCTION BOX
281V2-4	P0716281V2-4	R CAPACITOR 80M 250V 2 X 3-5/8
281V2-5	P0716281V2-5	MOTOR CORD 14G 3C 18"
281V2-6	P0716281V2-6	CIRCUIT BREAKER CRU 12A
282	P0716282	CAP SCREW M8-1.25 X 45
283	P0716283	HEX WRENCH 6MM
284	P0716284	HEX WRENCH 5MM
285	P0716285	COMBO WRENCH 11/13
286	P0716286	FLAT WASHER 8MM
287	P0716287	SPACER 8MM
288	P0716288	HEX NUT M5-.8
289	P0716289	HEX BOLT M10-1.5 X 35
290	P0716290	HOLDING PIN



# Machine Labels

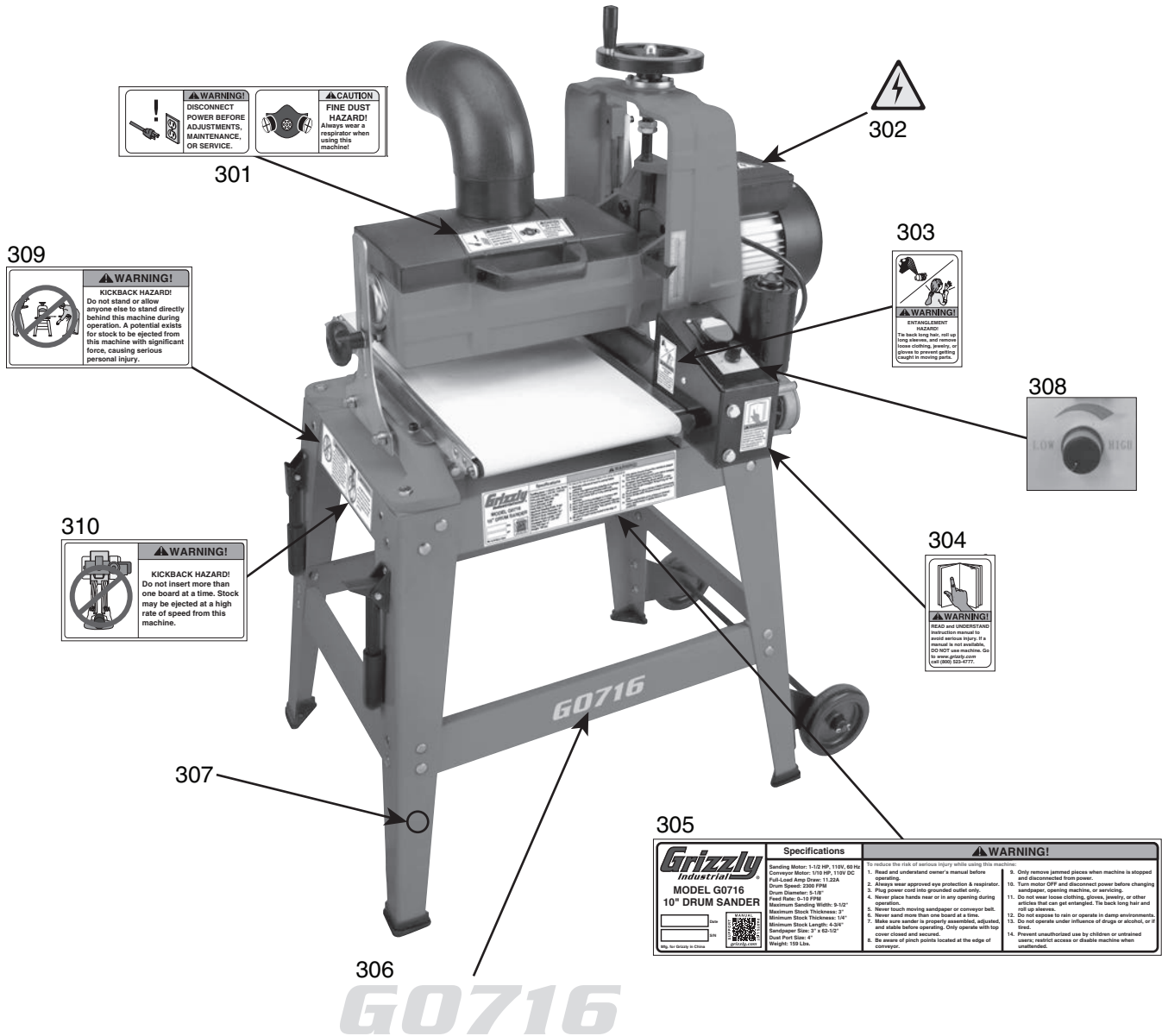

REF	PART #	DESCRIPTION
301	P0716301	DISCONNECT/DUST HAZARD LABEL
302	P0716302	ELECTRICITY LABEL
303	P0716303	ENTANGLEMENT HAZARD LABEL
304	P0716304	READ MANUAL LABEL
305	P0716305	MACHINE ID LABEL

REF	PART #	DESCRIPTION
306	P0716306	MODEL NUMBER LABEL
307	P0716307	GRIZZLY GREEN TOUCH-UP PAINT
308	P0716308	LO/HI SPEED LABEL
309	P0716309	SANDER REAR EJECT LABEL
310	P0716310	FEED ONE ONLY LABEL

## ⚠️ WARNING

Safety labels warn about machine hazards and ways to prevent injury. The owner of this machine **MUST** maintain the original location and readability of the labels on the machine. If any label is removed or becomes unreadable, **REPLACE** that label before using the machine again. Contact Grizzly at (800) 523-4777 or [www.grizzly.com](http://www.grizzly.com) to order new labels.







# WARRANTY CARD

Name \_\_\_\_\_  
 Street \_\_\_\_\_  
 City \_\_\_\_\_ State \_\_\_\_\_ Zip \_\_\_\_\_  
 Phone # \_\_\_\_\_ Email \_\_\_\_\_  
 Model # \_\_\_\_\_ Order # \_\_\_\_\_ Serial # \_\_\_\_\_

The following information is given on a voluntary basis. It will be used for marketing purposes to help us develop better products and services. **Of course, all information is strictly confidential.**

1. How did you learn about us?

Advertisement                       Friend                       Catalog  
 Card Deck                               Website                       Other:

2. Which of the following magazines do you subscribe to?

<input type="checkbox"/> Cabinetmaker & FDM	<input type="checkbox"/> Popular Science	<input type="checkbox"/> Wooden Boat
<input type="checkbox"/> Family Handyman	<input type="checkbox"/> Popular Woodworking	<input type="checkbox"/> Woodshop News
<input type="checkbox"/> Hand Loader	<input type="checkbox"/> Precision Shooter	<input type="checkbox"/> Woodsmith
<input type="checkbox"/> Handy	<input type="checkbox"/> Projects in Metal	<input type="checkbox"/> Woodwork
<input type="checkbox"/> Home Shop Machinist	<input type="checkbox"/> RC Modeler	<input type="checkbox"/> Woodworker West
<input type="checkbox"/> Journal of Light Cont.	<input type="checkbox"/> Rifle	<input type="checkbox"/> Woodworker's Journal
<input type="checkbox"/> Live Steam	<input type="checkbox"/> Shop Notes	<input type="checkbox"/> Other:
<input type="checkbox"/> Model Airplane News	<input type="checkbox"/> Shotgun News	
<input type="checkbox"/> Old House Journal	<input type="checkbox"/> Today's Homeowner	
<input type="checkbox"/> Popular Mechanics	<input type="checkbox"/> Wood	

3. What is your annual household income?

\$20,000-\$29,000                       \$30,000-\$39,000                       \$40,000-\$49,000  
 \$50,000-\$59,000                       \$60,000-\$69,000                       \$70,000+

4. What is your age group?

20-29                                       30-39                                       40-49  
 50-59                                       60-69                                       70+

5. How long have you been a woodworker/metalworker?

0-2 Years                       2-8 Years                       8-20 Years                       20+ Years

6. How many of your machines or tools are Grizzly?

0-2                       3-5                       6-9                       10+

7. Do you think your machine represents a good value?     Yes                       No

8. Would you recommend Grizzly Industrial to a friend?     Yes                       No

9. Would you allow us to use your name as a reference for Grizzly customers in your area?  
**Note: We never use names more than 3 times.**                       Yes                       No

10. Comments: \_\_\_\_\_  
 \_\_\_\_\_  
 \_\_\_\_\_  
 \_\_\_\_\_

CUT ALONG DOTTED LINE

FOLD ALONG DOTTED LINE

\_\_\_\_\_  
\_\_\_\_\_  
\_\_\_\_\_



Place  
Stamp  
Here



**GRIZZLY INDUSTRIAL, INC.**  
P.O. BOX 2069  
BELLINGHAM, WA 98227-2069



FOLD ALONG DOTTED LINE

Send a Grizzly Catalog to a friend:

Name \_\_\_\_\_  
Street \_\_\_\_\_  
City \_\_\_\_\_ State \_\_\_\_\_ Zip \_\_\_\_\_

TAPE ALONG EDGES--PLEASE DO NOT STAPLE

# WARRANTY AND RETURNS

---

Grizzly Industrial, Inc. warrants every product it sells for a period of **1 year** to the original purchaser from the date of purchase. This warranty does not apply to defects due directly or indirectly to misuse, abuse, negligence, accidents, repairs or alterations or lack of maintenance. This is Grizzly's sole written warranty and any and all warranties that may be implied by law, including any merchantability or fitness, for any particular purpose, are hereby limited to the duration of this written warranty. We do not warrant or represent that the merchandise complies with the provisions of any law or acts unless the manufacturer so warrants. In no event shall Grizzly's liability under this warranty exceed the purchase price paid for the product and any legal actions brought against Grizzly shall be tried in the State of Washington, County of Whatcom.

We shall in no event be liable for death, injuries to persons or property or for incidental, contingent, special, or consequential damages arising from the use of our products.

To take advantage of this warranty, contact us by mail or phone and give us all the details. We will then issue you a "Return Number," which must be clearly posted on the outside as well as the inside of the carton. We will not accept any item back without this number. Proof of purchase must accompany the merchandise.

The manufacturers reserve the right to change specifications at any time because they constantly strive to achieve better quality equipment. We make every effort to ensure that our products meet high quality and durability standards and we hope you never need to use this warranty.

Please feel free to write or call us if you have any questions about the machine or the manual.

Thank you again for your business and continued support. We hope to serve you again soon.

**grizzly.com**<sup>®</sup>  
**TOOL WEBSITE**

Buy Direct and Save with Grizzly<sup>®</sup> – Trusted, Proven and a Great Value!  
~Since 1983~

*Visit Our Website Today For  
Current Specials!*

**ORDER  
24 HOURS A DAY!  
1-800-523-4777**

