

# *Grizzly* *Industrial, Inc.*®

## **MODEL G0709** **14" x 40" GUNSMITHING LATHE** **OWNER'S MANUAL** *(For models manufactured since 01/21)*



COPYRIGHT © MAY, 2010 BY GRIZZLY INDUSTRIAL, INC., REVISED MARCH, 2021 (BL)  
**WARNING: NO PORTION OF THIS MANUAL MAY BE REPRODUCED IN ANY SHAPE  
OR FORM WITHOUT THE WRITTEN APPROVAL OF GRIZZLY INDUSTRIAL, INC.**  
#CR12646 PRINTED IN CHINA

V5.03.21



## **WARNING!**

**This manual provides critical safety instructions on the proper setup, operation, maintenance, and service of this machine/tool. Save this document, refer to it often, and use it to instruct other operators.**

**Failure to read, understand and follow the instructions in this manual may result in fire or serious personal injury—including amputation, electrocution, or death.**

**The owner of this machine/tool is solely responsible for its safe use. This responsibility includes but is not limited to proper installation in a safe environment, personnel training and usage authorization, proper inspection and maintenance, manual availability and comprehension, application of safety devices, cutting/sanding/grinding tool integrity, and the usage of personal protective equipment.**

**The manufacturer will not be held liable for injury or property damage from negligence, improper training, machine modifications or misuse.**



## **WARNING!**

**Some dust created by power sanding, sawing, grinding, drilling, and other construction activities contains chemicals known to the State of California to cause cancer, birth defects or other reproductive harm. Some examples of these chemicals are:**

- **Lead from lead-based paints.**
- **Crystalline silica from bricks, cement and other masonry products.**
- **Arsenic and chromium from chemically-treated lumber.**

**Your risk from these exposures varies, depending on how often you do this type of work. To reduce your exposure to these chemicals: Work in a well ventilated area, and work with approved safety equipment, such as those dust masks that are specially designed to filter out microscopic particles.**

# Table of Contents

<b>INTRODUCTION</b> .....	<b>2</b>	<b>SECTION 5: ACCESSORIES</b> .....	<b>49</b>
Machine Description .....	2	<b>SECTION 6: MAINTENANCE</b> .....	<b>52</b>
Contact Info .....	2	Schedule .....	52
Manual Accuracy .....	2	Unpainted Cast Iron .....	52
Identification .....	3	Cleaning .....	52
Machine Data Sheet .....	4	Ball Oiler Lubrication .....	52
<b>SECTION 1: SAFETY</b> .....	<b>7</b>	Oil Reservoirs .....	54
Safety Instructions for Machinery .....	7	V-Belt Tension .....	55
Additional Safety for Metal Lathes .....	9	Cutting Fluid System .....	56
Additional Chuck Safety .....	10	<b>SECTION 7: SERVICE</b> .....	<b>57</b>
<b>SECTION 2: POWER SUPPLY</b> .....	<b>11</b>	Gib Adjustments .....	59
<b>SECTION 3: SETUP</b> .....	<b>13</b>	Backlash Adjustment .....	61
Preparation .....	13	Half Nut Adjustment .....	62
Unpacking .....	13	Leadscrew Endplay Adjustment .....	62
Needed for Setup .....	13	Shear Pin Replacement .....	63
Inventory .....	14	Feed Rod Clutch Adjustment .....	64
Cleanup .....	15	Tailstock Lock .....	65
Site Considerations .....	16	Bearing Preload .....	65
Lifting & Moving .....	17	V-Belt Replacement .....	68
Anchoring to Floor .....	17	Brake Shoes .....	68
Leveling .....	18	Machine Storage .....	69
Lubricating Lathe .....	18	<b>SECTION 8: WIRING</b> .....	<b>71</b>
Adding Cutting Fluid .....	18	Wiring Safety Instructions .....	71
Power Connection .....	19	Wiring Overview .....	72
Test Run .....	19	Electrical Box Wiring .....	73
Spindle Break-In .....	22	Switches and Pump Motor .....	74
Recommended Adjustments .....	22	Spindle Motor Connection .....	75
<b>SECTION 4: OPERATION</b> .....	<b>23</b>	Electrical Box Photo .....	76
Operation Overview .....	23	<b>SECTION 9: PARTS</b> .....	<b>77</b>
Controls .....	24	Headstock Case and Shift .....	77
Chuck & Faceplate Removal/Installation .....	27	Headstock Drive .....	79
Three-Jaw Chuck .....	30	Headstock Spindle .....	81
Four-Jaw Chuck .....	31	Change Gears .....	83
Faceplate .....	32	Quick Change Gearbox Drive .....	84
Centers .....	33	Quick Change Gearbox Shift .....	86
Tailstock .....	35	Apron .....	88
Offsetting Tailstock .....	35	Cross Slide .....	90
Aligning Tailstock .....	36	Compound Slide .....	92
Drilling with Tailstock .....	37	Rests .....	93
Cutting Fluid System .....	39	Tailstock .....	94
Steady Rest & Follow Rest .....	39	Pump .....	96
Tool Post .....	40	Motor & Feed Rod .....	97
Spider .....	41	Cabinet and Brake .....	99
Spindle Speed .....	41	Main Electrical Breakdown .....	101
Manual Feed .....	43	Accessories .....	102
Power Feed .....	43	Labels & Cosmetics .....	103
Feed Settings .....	44	Labels & Cosmetics (Cont.) .....	104
Thread Settings .....	45	<b>WARRANTY &amp; RETURNS</b> .....	<b>105</b>

# INTRODUCTION

## Machine Description

The purpose of a metal lathe is to face, turn, knurl, thread, bore, or cut tapers in a metal workpiece with perfect accuracy.

During typical operations, the lathe spindle rotates the workpiece at various speeds against a fixed cutting tool that is positioned at a particular angle for the desired type of cut.

The cutting tool is mounted on a tool post, which is positioned by three different slides that each move in different directions.

Opposite of the headstock and spindle is a support device called a tailstock. The tailstock can be slid along the lathe bed and locked in place to firmly support the end of a workpiece.

## Contact Info

We stand behind our machines! If you have questions or need help, contact us with the information below. Before contacting, make sure you get the **serial number** and **manufacture date** from the machine ID label. This will help us help you faster.

Grizzly Technical Support  
1815 W. Battlefield  
Springfield, MO 65807  
Phone: (570) 546-9663  
Email: techsupport@grizzly.com

We want your feedback on this manual. What did you like about it? Where could it be improved? Please take a few minutes to give us feedback.

Grizzly Documentation Manager  
P.O. Box 2069  
Bellingham, WA 98227-2069  
Email: manuals@grizzly.com

## Manual Accuracy

We are proud to provide a high-quality owner's manual with your new machine!

We made every effort to be exact with the instructions, specifications, drawings, and photographs in this manual. Sometimes we make mistakes, but our policy of continuous improvement also means that **sometimes the machine you receive is slightly different than shown in the manual.**

If you find this to be the case, and the difference between the manual and machine leaves you confused or unsure about something, check our website for an updated version. We post current manuals and manual updates for free on our website at [www.grizzly.com](http://www.grizzly.com).

Alternatively, you can call our Technical Support for help. Before calling, make sure you write down the **Manufacture Date** and **Serial Number** from the machine ID label (see below). This information is required for us to provide proper tech support, and it helps us determine if updated documentation is available for your machine.

**Grizzly Industrial** MODEL GXXXX MACHINE NAME

**WARNING!**  
To reduce risk of serious injury when using this machine:  
1. Read manual before operation.  
2. Wear safety glasses and respirator.  
3. Make sure safety glasses and respirator are properly adjusted/setup and used.  
4. Make sure the motor has stopped and disconnect power before adjustments, maintenance, or service.  
5. DO NOT expose to rain or dampness.  
6. DO NOT modify this machine in any way.  
7. Do not use alcohol or flammable liquids.  
8. Do not use the machine if you are tired, drowsy, or have consumed alcohol or drugs.  
9. Do not use the machine if you are under the influence of alcohol or drugs.  
10. Maintain machine carefully to prevent accidents.

**SPECIFICATIONS**

Motor: \_\_\_\_\_  
Specification: \_\_\_\_\_  
Specification: \_\_\_\_\_  
Specification: \_\_\_\_\_  
Weight: \_\_\_\_\_

Manufacture Date: \_\_\_\_\_  
Serial Number: \_\_\_\_\_

Manufactured for Grizzly in Taiwan



# Identification

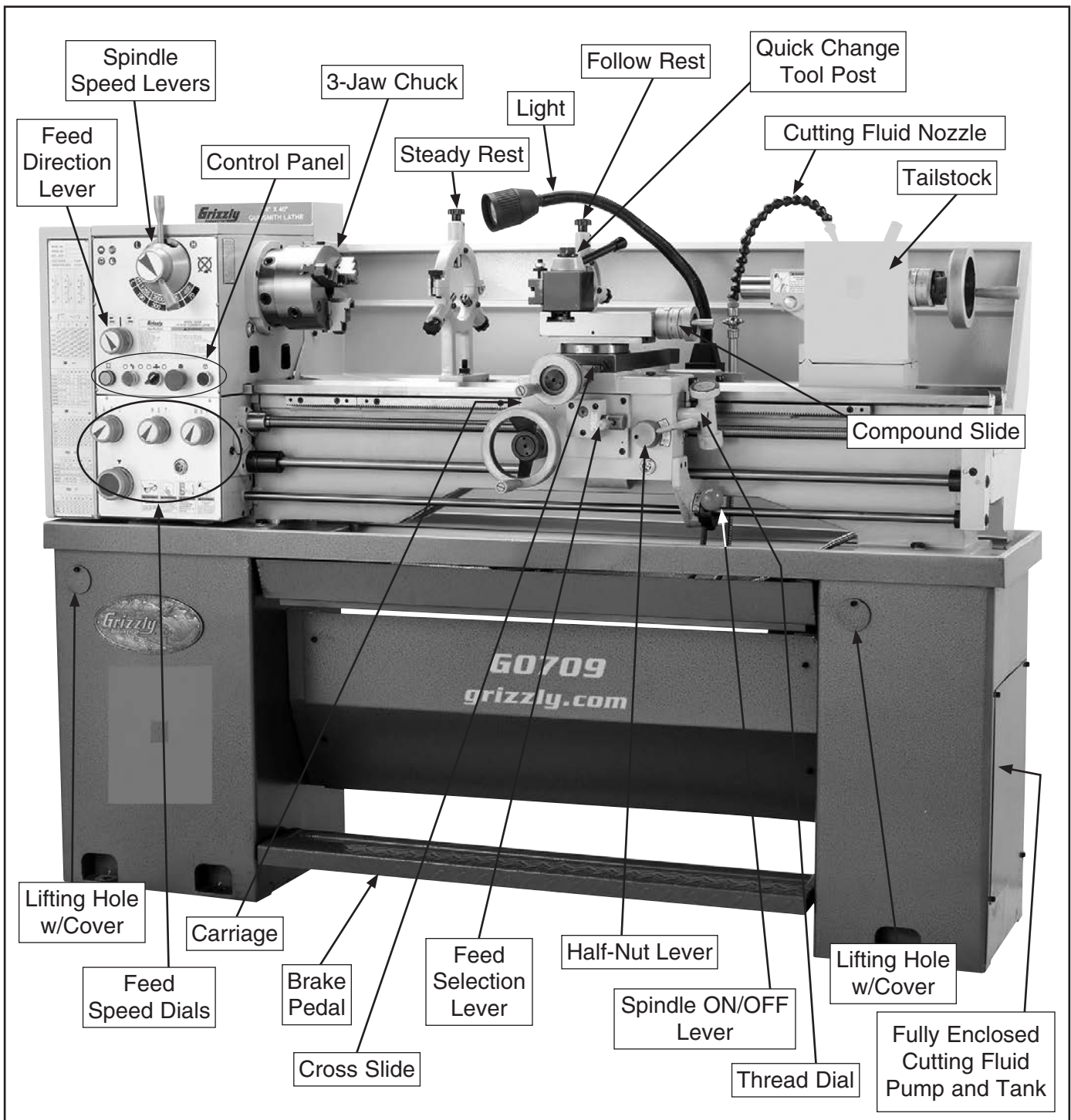


Figure 1. Lathe features.





# MACHINE DATA SHEET

Customer Service #: (570) 546-9663 · To Order Call: (800) 523-4777 · Fax #: (800) 438-5901

## MODEL G0709 14" X 40" GUNSMITHING GEARHEAD LATHE

### Product Dimensions:

Weight..... 1300 lbs.  
Width (side-to-side) x Depth (front-to-back) x Height..... 71-1/2 x 26-3/16 x 52 in.  
Footprint (Length x Width)..... 70-3/8 x 15-3/4 in.

### Shipping Dimensions:

Type..... Wood Crate  
Content..... Machine  
Weight..... 1550 lbs.  
Length x Width x Height..... 76 x 30 x 61 in.

### Electrical:

Power Requirement..... 220V, Single-Phase, 60 Hz  
Full-Load Current Rating..... 10A  
Minimum Circuit Size..... 15A  
Connection Type..... Cord & Plug  
Power Cord Included..... No  
Plug Included..... No  
Recommended Plug Type..... 6-15  
Switch Type..... Control Panel w/Magnetic Switch Protection

### Motors:

#### Main

Horsepower..... 2 HP  
Phase..... Single-Phase  
Amps..... 10A  
Speed..... 1725 RPM  
Type..... TEFC Capacitor-Start Induction  
Power Transfer ..... V-Belt Drive  
Bearings..... Shielded & Permanently Lubricated  
Centrifugal Switch/Contacts Type..... Internal

### Main Specifications:

#### Operation Info

Swing Over Bed..... 14 in.  
Distance Between Centers..... 40 in.  
Swing Over Cross Slide..... 8-13/16 in.  
Swing Over Saddle..... 13-13/16 in.  
Maximum Tool Bit Size..... 5/8 in.  
Compound Travel..... 3-9/16 in.  
Carriage Travel..... 36 in.  
Cross Slide Travel..... 6-11/16 in.





### Headstock Info

Spindle Bore.....	1.57 in.
Spindle Taper.....	MT#5
Number of Spindle Speeds.....	8
Spindle Speeds.....	70 – 2000 RPM
Spindle Type.....	D1-5 Camlock
Spindle Bearings.....	NSK Tapered Roller
Spindle Length.....	17 in.
Spindle Length with 3-Jaw Chuck.....	21-7/8 in.
Spindle Length with 4-Jaw Chuck.....	21-1/4 in.
Spindle Length with Faceplate.....	18-1/2 in.

### Tailstock Info

Tailstock Quill Travel.....	3-15/16 in.
Tailstock Taper.....	MT#3
Tailstock Barrel Diameter.....	1.656 in.

### Threading Info

Number of Longitudinal Feeds.....	24
Range of Longitudinal Feeds.....	0.00168 – 0.1175 in./rev.
Number of Cross Feeds.....	32
Range of Cross Feeds.....	0.00046 – 0.03231 in./rev
Number of Inch Threads.....	42
Range of Inch Threads.....	4 – 112 TPI
Number of Metric Threads.....	44
Range of Metric Threads.....	0.1 – 7.0 mm
Number of Modular Pitches.....	34
Range of Modular Pitches.....	0.1 – 1.75 MP
Number of Diametral Pitches.....	25
Range of Diametral Pitches.....	16 – 112 DP

### Dimensions

Bed Width.....	7-3/8 in.
Carriage Leadscrew Diameter.....	7/8 in.
Leadscrew TPI.....	8 TPI
Carriage Leadscrew Length.....	50 in.
Steady Rest Capacity.....	3/8 – 2-3/4 in.
Follow Rest Capacity.....	3/8 – 2-3/8 in.
Faceplate Size.....	11 in.
Feed Rod Diameter.....	3/4 in.
Floor to Center Height.....	45 in.

### Construction

Base.....	Steel
Headstock.....	Cast Iron
End Gears.....	Flame-Hardened Steel
Bed.....	Induction-Hardened, Precision-Ground Cast Iron
Body.....	Cast Iron
Stand.....	Steel
Paint Type/Finish.....	Epoxy

### Fluid Capacities

Headstock Capacity.....	4 qt.
Headstock Fluid Type.....	ISO 32 (eg. Grizzly T23963, Mobil DTE Light)
Gearbox Capacity.....	26 oz.
Gearbox Fluid Type.....	ISO 68 (eg. Grizzly T23962, Mobil Vactra 2)
Apron Capacity.....	7 oz.
Apron Fluid Type.....	ISO 68 (eg. Grizzly T23962, Mobil Vactra 2)
Coolant Capacity.....	10 qt.



Country of Origin .....	China
Warranty .....	1 Year
Approximate Assembly & Setup Time .....	1 Hour
Serial Number Location .....	ID Label on Front of Lathe
Sound Rating .....	82 dB

**Features:**

- NSK precision tapered roller spindle bearings
- Flame hardened headstock gears
- Induction-hardened and precision-ground cast-iron bed
- Coolant system
- Adjustable halogen work light
- Foot brake with motor shut-off switch
- Full-length splash guard
- Pull-out chip tray
- 200-Series quick-change tool post
- Outboard spindle spider mount with 4 brass-tipped screws
- Cast-iron cabinet stands
- Fully enclosed quick-change gearbox
- Tailstock offset V-slide with wrench locking socket
- D1-5 Camlock Spindle

**Accessories Included:**

- 6" 3-Jaw chuck with reversible jaws
- 8" 4-Jaw chuck with independent jaws
- 11" Faceplate
- MT#3 live center
- Standard MT#3 dead center
- Carbide-tipped MT#3 dead center
- MT#5-MT#3 sleeve
- 1/2" Drill chuck with MT#3 arbor
- Tailstock wrench
- Service tools
- Toolbox





# SECTION 1: SAFETY

## For Your Own Safety, Read Instruction Manual Before Operating This Machine

The purpose of safety symbols is to attract your attention to possible hazardous conditions. This manual uses a series of symbols and signal words intended to convey the level of importance of the safety messages. The progression of symbols is described below. Remember that safety messages by themselves do not eliminate danger and are not a substitute for proper accident prevention measures. Always use common sense and good judgment.



Indicates an imminently hazardous situation which, if not avoided, **WILL** result in death or serious injury.



Indicates a potentially hazardous situation which, if not avoided, **COULD** result in death or serious injury.



Indicates a potentially hazardous situation which, if not avoided, **MAY** result in minor or moderate injury. It may also be used to alert against unsafe practices.

**NOTICE**

Alerts the user to useful information about proper operation of the machine to avoid machine damage.

## Safety Instructions for Machinery

### **WARNING**

**OWNER'S MANUAL.** Read and understand this owner's manual **BEFORE** using machine.

**TRAINED OPERATORS ONLY.** Untrained operators have a higher risk of being hurt or killed. Only allow trained/supervised people to use this machine. When machine is not being used, disconnect power, remove switch keys, or lock-out machine to prevent unauthorized use—especially around children. Make your workshop kid proof!

**DANGEROUS ENVIRONMENTS.** Do not use machinery in areas that are wet, cluttered, or have poor lighting. Operating machinery in these areas greatly increases the risk of accidents and injury.

**MENTAL ALERTNESS REQUIRED.** Full mental alertness is required for safe operation of machinery. Never operate under the influence of drugs or alcohol, when tired, or when distracted.

#### **ELECTRICAL EQUIPMENT INJURY RISKS.**

You can be shocked, burned, or killed by touching live electrical components or improperly grounded machinery. To reduce this risk, only allow qualified service personnel to do electrical installation or repair work, and always disconnect power before accessing or exposing electrical equipment.

**DISCONNECT POWER FIRST.** Always disconnect machine from power supply **BEFORE** making adjustments, changing tooling, or servicing machine. This prevents an injury risk from unintended startup or contact with live electrical components.

**EYE PROTECTION.** Always wear ANSI-approved safety glasses or a face shield when operating or observing machinery to reduce the risk of eye injury or blindness from flying particles. Everyday eyeglasses are **NOT** approved safety glasses.



# WARNING

**WEARING PROPER APPAREL.** Do not wear clothing, apparel or jewelry that can become entangled in moving parts. Always tie back or cover long hair. Wear non-slip footwear to reduce risk of slipping and losing control or accidentally contacting cutting tool or moving parts.

**HAZARDOUS DUST.** Dust created by machinery operations may cause cancer, birth defects, or long-term respiratory damage. Be aware of dust hazards associated with each workpiece material. Always wear a NIOSH-approved respirator to reduce your risk.

**HEARING PROTECTION.** Always wear hearing protection when operating or observing loud machinery. Extended exposure to this noise without hearing protection can cause permanent hearing loss.

**REMOVE ADJUSTING TOOLS.** Tools left on machinery can become dangerous projectiles upon startup. Never leave chuck keys, wrenches, or any other tools on machine. Always verify removal before starting!

**USE CORRECT TOOL FOR THE JOB.** Only use this tool for its intended purpose—do not force it or an attachment to do a job for which it was not designed. Never make unapproved modifications—modifying tool or using it differently than intended may result in malfunction or mechanical failure that can lead to personal injury or death!

**AWKWARD POSITIONS.** Keep proper footing and balance at all times when operating machine. Do not overreach! Avoid awkward hand positions that make workpiece control difficult or increase the risk of accidental injury.

**CHILDREN & BYSTANDERS.** Keep children and bystanders at a safe distance from the work area. Stop using machine if they become a distraction.

**GUARDS & COVERS.** Guards and covers reduce accidental contact with moving parts or flying debris. Make sure they are properly installed, undamaged, and working correctly BEFORE operating machine.

**FORCING MACHINERY.** Do not force machine. It will do the job safer and better at the rate for which it was designed.

**NEVER STAND ON MACHINE.** Serious injury may occur if machine is tipped or if the cutting tool is unintentionally contacted.

**STABLE MACHINE.** Unexpected movement during operation greatly increases risk of injury or loss of control. Before starting, verify machine is stable and mobile base (if used) is locked.

**USE RECOMMENDED ACCESSORIES.** Consult this owner's manual or the manufacturer for recommended accessories. Using improper accessories will increase the risk of serious injury.

**UNATTENDED OPERATION.** To reduce the risk of accidental injury, turn machine **OFF** and ensure all moving parts completely stop before walking away. Never leave machine running while unattended.

**MAINTAIN WITH CARE.** Follow all maintenance instructions and lubrication schedules to keep machine in good working condition. A machine that is improperly maintained could malfunction, leading to serious personal injury or death.

**DAMAGED PARTS.** Regularly inspect machine for damaged, loose, or mis-adjusted parts—or any condition that could affect safe operation. Immediately repair/replace BEFORE operating machine. For your own safety, DO NOT operate machine with damaged parts!

**MAINTAIN POWER CORDS.** When disconnecting cord-connected machines from power, grab and pull the plug—NOT the cord. Pulling the cord may damage the wires inside. Do not handle cord/plug with wet hands. Avoid cord damage by keeping it away from heated surfaces, high traffic areas, harsh chemicals, and wet/damp locations.

**EXPERIENCING DIFFICULTIES.** If at any time you experience difficulties performing the intended operation, stop using the machine! Contact our Technical Support at (570) 546-9663.



# Additional Safety for Metal Lathes

## WARNING

Serious injury or death can occur from getting entangled in, crushed between, or struck by rotating parts on a lathe! Unsecured tools or workpieces that fly loose from rotating objects can also strike nearby operators with deadly force. To minimize the risk of getting hurt or killed, anyone operating this machine **MUST** completely heed the hazards and warnings below.

**CLOTHING, JEWELRY & LONG HAIR.** Tie back long hair, remove jewelry, and do not wear loose clothing or gloves. These can easily get caught on rotating parts and pull you into lathe.

**ROTATING PARTS.** Always keep hands and body at a safe distance from rotating parts—especially those with projecting surfaces. Never hold anything against rotating workpiece, such as emery cloth, that can pull you into lathe.

**GUARDING.** Guards and covers protect against entanglement or flying objects. Always ensure they are properly installed while machine is running.

**ADJUSTMENT TOOLS.** Remove all chuck keys, wrenches, and adjustment tools before turning lathe **ON**. A tool left on the lathe can become a deadly projectile when spindle is started.

**SAFE CLEARANCES.** Before starting spindle, verify workpiece has adequate clearance by hand-rotating it through its entire range of motion.

**NEW SETUPS.** Test each new setup by starting spindle rotation at the lowest speed and standing to the side of the lathe until workpiece reaches full speed and you can verify safe rotation.

**SPINDLE SPEEDS.** Using spindle speeds that are too fast for the workpiece or clamping equipment can cause rotating parts to come loose and strike nearby people with deadly force. Always use slow spindle speeds with large or non-concentric workpieces. Never exceed rated RPM of the chuck.

**LONG STOCK SAFETY.** Long stock can whip violently if not properly supported. Always support any stock that extends from the chuck/headstock more than three times its own diameter.

**CLEARING CHIPS.** Metal chips can be razor sharp. Avoid clearing them by hand or with a rag. Use a brush or vacuum instead.

**SECURE WORKPIECE.** An improperly secured workpiece can fly off spindle with deadly force. Make sure workpiece is properly secured before starting the lathe.

**CHUCKS.** Chucks can be heavy and difficult to hold. During installation and removal, protect your hands and precision bed ways by using a chuck cradle or piece of plywood over the bed ways. Use lifting equipment, as necessary, for large chucks.

**STOPPING SPINDLE.** Always allow spindle to completely stop on its own, or use a brake, if provided. Never put hands or another object on a spinning workpiece to make it stop faster.

**CRASHING.** A serious explosion of metal parts can occur if cutting tool or other lathe component hits rotating chuck or a projecting part of workpiece. Resulting metal fragments can strike nearby people and lathe will be seriously damaged. To reduce risk of crashing, **ALWAYS** release automatic feeds after use, **NEVER** leave lathe unattended, and **CHECK** all clearances before starting lathe.

**COOLANT SAFETY.** Coolant can become very toxic through prolonged use and aging. To minimize toxicity, change coolant regularly. When using, position nozzle properly to avoid splashing operator or causing a slipping hazard on floor.

**TOOL SELECTION.** Cutting with incorrect or dull tooling increases risk of injury from broken or dislodged components, or as a result of extra force required for operation. Always use sharp tooling that is right for the job.

**SANDING/POLISHING.** To reduce risk of entanglement, never wrap emery cloth around rotating workpiece. Instead, use emery cloth with the aid of a tool or backing board.

**MEASURING WORKPIECE.** To reduce risk of entanglement, never measure rotating workpieces.



# Additional Chuck Safety

## **WARNING**

**ENTANGLEMENT.** Entanglement with a rotating chuck can lead to death, amputation, broken bones, or other serious injury. Never attempt to slow or stop the lathe chuck by hand, and always roll up long sleeves, tie back long hair, and remove any jewelry or loose apparel **BEFORE** operating.

**CHUCK SPEED RATING.** Excessive spindle speeds greatly increase the risk of the workpiece or chuck being thrown from the machine with deadly force. Never use spindle speeds faster than the chuck RPM rating or the safe limits of your workpiece.

**USING CORRECT EQUIPMENT.** Many workpieces can only be safely turned in a lathe if additional support equipment, such as a tailstock or steady/follow rest, is used. If the operation is too hazardous to be completed with the lathe or existing equipment, the operator must have enough experience to know when to use a different machine or find a safer way.

**TRAINED OPERATORS ONLY.** Using a chuck incorrectly can result in workpieces coming loose at high speeds and striking the operator or bystanders with deadly force. To reduce the risk of this hazard, read and understand this document and seek additional training from an experienced chuck user before using a chuck.

**CHUCK CAPACITY.** Avoid exceeding the capacity of the chuck by clamping an oversized workpiece. If the workpiece is too large to safely clamp with the chuck, use a faceplate or a larger chuck if possible. Otherwise, the workpiece could be thrown from the lathe during operation, resulting in serious impact injury or death.

**CLAMPING FORCE.** Inadequate clamping force can lead to the workpiece being thrown from the chuck and striking the operator or bystanders. Maximum clamping force is achieved when the chuck is properly maintained and lubricated, all jaws are fully engaged with the workpiece, and the maximum chuck clamping diameter is not exceeded.

**PROPER MAINTENANCE.** All chucks must be properly maintained and lubricated to achieve maximum clamping force and withstand the rigors of centrifugal force. To reduce the risk of a thrown workpiece, follow all maintenance intervals and instructions in this document.

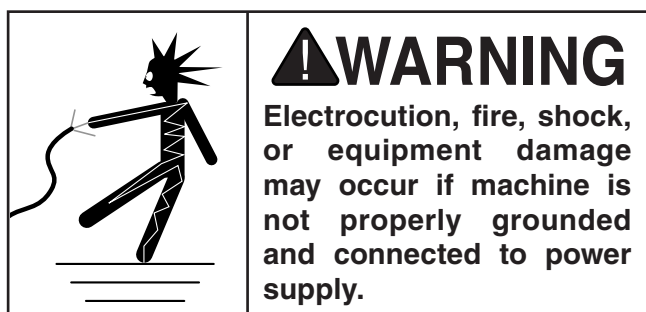
**DISCONNECT POWER.** Serious entanglement or impact injuries could occur if the lathe is started while you are adjusting, servicing, or installing the chuck. Always disconnect the lathe from power before performing these procedures.



# SECTION 2: POWER SUPPLY

## Availability

Before installing the machine, consider the availability and proximity of the required power supply circuit. If an existing circuit does not meet the requirements for this machine, a new circuit must be installed. To minimize the risk of electrocution, fire, or equipment damage, installation work and electrical wiring must be done by an electrician or qualified service personnel in accordance with all applicable codes and standards.



## Full-Load Current Rating

The full-load current rating is the amperage a machine draws at 100% of the rated output power. On machines with multiple motors, this is the amperage drawn by the largest motor or sum of all motors and electrical devices that might operate at one time during normal operations.

### Full-Load Current Rating at 220V ..... 10 Amps

The full-load current is not the maximum amount of amps that the machine will draw. If the machine is overloaded, it will draw additional amps beyond the full-load rating.

If the machine is overloaded for a sufficient length of time, damage, overheating, or fire may result—especially if connected to an undersized circuit. To reduce the risk of these hazards, avoid overloading the machine during operation and make sure it is connected to a power supply circuit that meets the specified circuit requirements.

## Circuit Requirements for 220V

This machine is prewired to operate on a power supply circuit that has a verified ground and meets the following requirements:

**Nominal Voltage ..... 220V/240V**  
**Cycle.....60 Hz**  
**Phase..... 1-Phase**  
**Circuit Rating..... 15 Amps**  
**Plug/Receptacle ..... NEMA 6-15**  
**Cord .....3-Wire, 14 AWG, 300VAC, “S”-Type**

A power supply circuit includes all electrical equipment between the breaker box or fuse panel in the building and the machine. The power supply circuit used for this machine must be sized to safely handle the full-load current drawn from the machine for an extended period of time. (If this machine is connected to a circuit protected by fuses, use a time delay fuse marked D.)



**Note:** *Circuit requirements in this manual apply to a dedicated circuit—where only one machine will be running on the circuit at a time. If machine will be connected to a shared circuit where multiple machines may be running at the same time, consult an electrician or qualified service personnel to ensure circuit is properly sized for safe operation.*

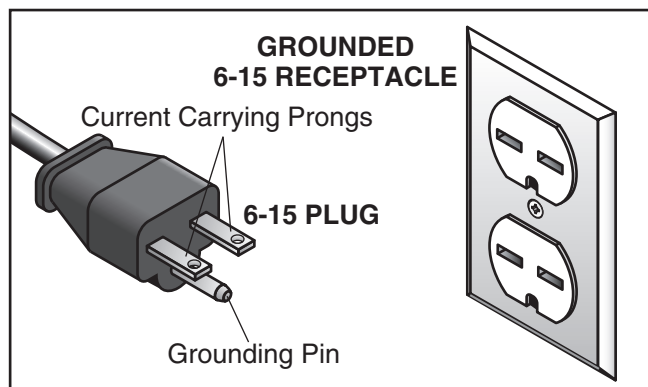




## Grounding Instructions

This machine **MUST** be grounded. In the event of certain malfunctions or breakdowns, grounding reduces the risk of electric shock by providing a path of least resistance for electric current.

The power cord and plug specified under “Circuit Requirements for 220V” on the previous page has an equipment-grounding wire and a grounding prong. The plug must only be inserted into a matching receptacle (outlet) that is properly installed and grounded in accordance with all local codes and ordinances (see figure below).



**Figure 2.** NEMA 6-15 plug and receptacle.

### **⚠ WARNING**

**Serious injury could occur if you connect machine to power before completing setup process. DO NOT connect to power until instructed later in this manual.**

Improper connection of the equipment-grounding wire can result in a risk of electric shock. The wire with green insulation (with or without yellow stripes) is the equipment-grounding wire. If repair or replacement of the power cord or plug is necessary, do not connect the equipment-grounding wire to a live (current carrying) terminal.

Check with a qualified electrician or service personnel if you do not understand these grounding requirements, or if you are in doubt about whether the tool is properly grounded. If you ever notice that a cord or plug is damaged or worn, disconnect it from power, and immediately replace it with a new one.

## Extension Cords

We do not recommend using an extension cord with this machine. If you must use an extension cord, only use it if absolutely necessary and only on a temporary basis.

Extension cords cause voltage drop, which can damage electrical components and shorten motor life. Voltage drop increases as the extension cord size gets longer and the gauge size gets smaller (higher gauge numbers indicate smaller sizes).

Any extension cord used with this machine must be in good condition and contain a ground wire and matching plug/receptacle. Additionally, it must meet the following size requirements:

**Minimum Gauge Size ..... 14 AWG**  
**Maximum Length (Shorter is Better).....50 ft.**



# SECTION 3: SETUP

---

---

## Preparation

---

The list below outlines the basic process of preparing your machine for operation. Specific steps are covered later in this section.

**The typical preparation process is as follows:**

1. Unpack the lathe and inventory the contents of the box/crate.
2. Clean the lathe and its components.
3. Identify an acceptable location for the lathe and move it to that location.
4. Level the lathe and bolt it to the floor.
5. Assemble the loose components and make any necessary adjustments or inspections to ensure the lathe is ready for operation.
6. Check lathe for proper lubrication.
7. Connect the lathe to the power source.
8. Test run lathe to ensure it functions properly.
9. Perform the spindle break-in procedure to prepare the lathe for operation.

## Unpacking

---

This machine was carefully packaged for safe transport. When unpacking, separate all enclosed items from packaging materials and inspect them for shipping damage. ***If items are damaged, please call us immediately at (570) 546-9663.***

**IMPORTANT:** Save all packaging materials until you are completely satisfied with the machine and have resolved any issues between Grizzly or the shipping agent. *You MUST have the original packaging to file a freight claim. It is also extremely helpful if you need to return your machine later.*

## Needed for Setup

---

The following are needed to complete the setup process, but are not included with your machine.

Description	Qty
• Forklift or Hoist (Rated 2000 lbs.) .....	1
• Lifting Straps (Rated 2000 lbs.).....	2
• Lifting Hooks (Rated 2000 lbs.).....	2
• Machinist's Level .....	1
• Degreaser/Solvent Cleaner .....	as needed
• Shop Rags for Cleaning .....	as needed
• Stiff Brush for Cleaning .....	1





# Inventory

The following is a list of items shipped with your machine. Before beginning setup, lay these items out and inventory them.

If any non-proprietary parts are missing (e.g. a nut or a washer), we will gladly replace them; or for the sake of expediency, replacements can be obtained at your local hardware store.

Mounted Inventory Components	Qty
A. Three-Jaw Chuck 6".....	1
B. Steady Rest.....	1
C. Follow Rest.....	1
D. Quick Change Tool Post w/Holder .....	1

Loose Inventory Components	Qty
E. Four-Jaw Chuck 8".....	1
F. Toolbox.....	1
G. Four-Jaw Chuck Wrench.....	1
H. Faceplate 11".....	1
I. Faceplate Camlock Set .....	1

Toolbox Inventory Components	Qty
J. Bottle for Oil .....	1
K. Spindle Sleeve MT#5/MT#3 .....	1
L. Dead Center MT#3 Carbide Tip .....	1
M. Dead Center MT#3 HSS Tip .....	1
N. Live Center MT#3.....	1
O. Tailstock Lock Lever.....	1
P. Handles .....	2
Q. Chuck Arbor MT#3/JT3 .....	1
R. Hex Wrenches 2.5, 3, 4, 5, 6, 8mm .....	1 Ea.
S. Three-Jaw Chuck Key .....	1
T. Open-End Wrench Set 9/11, 12/14, 13/16, 17/19, 24/27mm.....	1 Ea.
U. Drill Chuck Key.....	1
V. Drill Chuck 1/2"-JT3 .....	1
W. Phillips and Standard Screwdriver #2 .....	1
X. Tool Holder (One Installed) .....	2
Y. Spider Screws M10-1.5 x 35.....	8
—Hex Nuts M10-1.5 .....	4

## NOTICE

If you cannot find an item on this list, carefully check around/inside the machine and packaging materials. Often, these items get lost in packaging materials while unpacking or they are pre-installed at the factory.

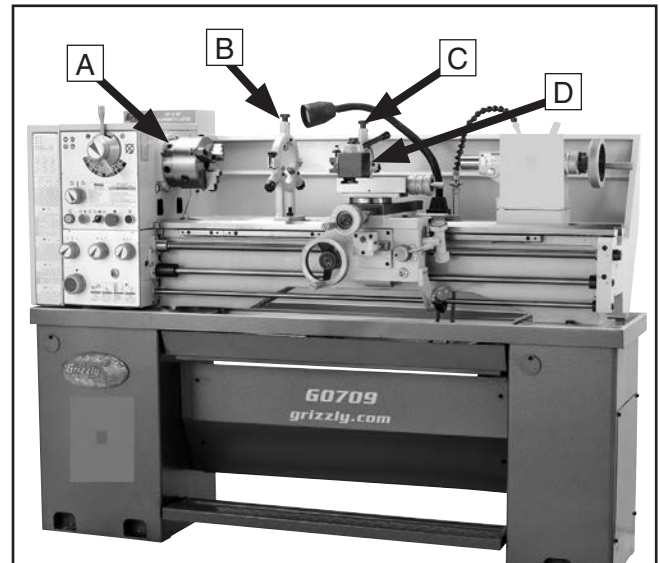


Figure 3. Mounted inventory components.

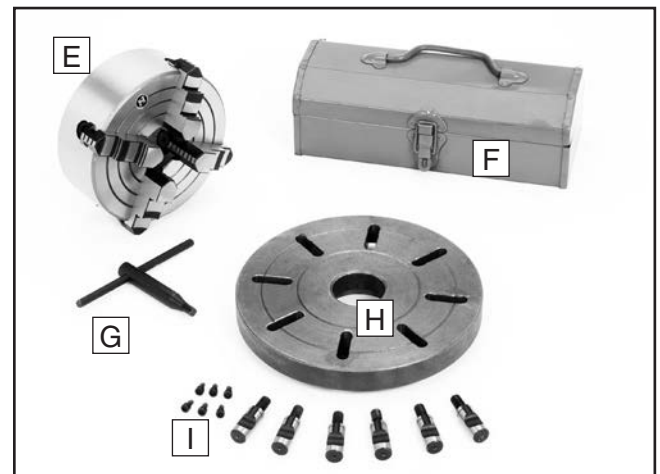


Figure 4. Loose inventory components.

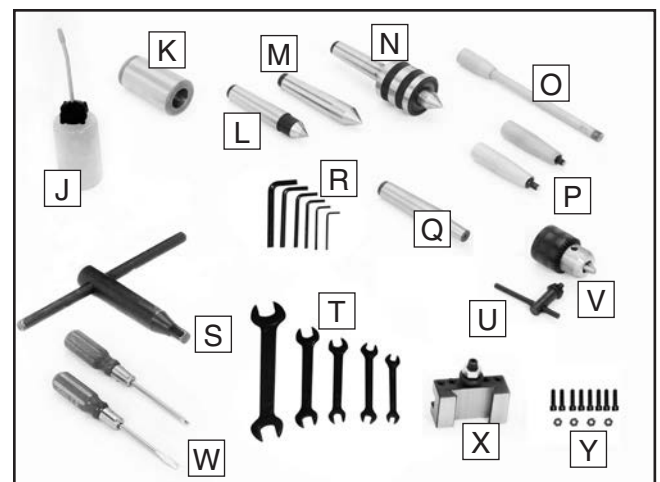


Figure 5. Toolbox inventory.



# Cleanup

The unpainted surfaces of your machine are coated with a heavy-duty rust preventative that prevents corrosion during shipment and storage. This rust preventative works extremely well, but it will take a little time to clean.

Be patient and do a thorough job cleaning your machine. The time you spend doing this now will give you a better appreciation for the proper care of your machine's unpainted surfaces.


There are many ways to remove this rust preventative, but the following steps work well in a wide variety of situations. Always follow the manufacturer's instructions with any cleaning product you use and make sure you work in a well-ventilated area to minimize exposure to toxic fumes.


## Before cleaning, gather the following:

- Disposable rags
- Cleaner/degreaser (WD-40 works well)
- Safety glasses & disposable gloves
- Plastic paint scraper (optional)

## Basic steps for removing rust preventative:

1. Put on safety glasses.
2. Coat the rust preventative with a liberal amount of cleaner/degreaser, then let it soak for 5–10 minutes.
3. Wipe off the surfaces. If your cleaner/degreaser is effective, the rust preventative will wipe off easily. If you have a plastic paint scraper, scrape off as much as you can first, then wipe off the rest with the rag.
4. Repeat **Steps 2–3** as necessary until clean, then coat all unpainted surfaces with a quality metal protectant to prevent rust.

	<b>⚠️ WARNING</b> Gasoline and petroleum products have low flash points and can explode or cause fire if used to clean machinery. Avoid using these products to clean machinery.
--	---

	<b>⚠️ CAUTION</b> Many cleaning solvents are toxic if inhaled. Only work in a well-ventilated area.
--	--

<b>NOTICE</b> Avoid harsh solvents like acetone or brake parts cleaner that may damage painted surfaces. Always test on a small, inconspicuous location first.
---

## T23692—Orange Power Degreaser

A great product for removing the waxy shipping grease from the **non-painted** parts of the machine during clean up.

<p>Call <b>1-800-523-4777</b> To Order</p>	
--	---

## Additional Cleaning Tips

- For thorough cleaning, remove steady rest, tool post, compound slide, and change-gears.
- Use stiff brush when cleaning threads on leadscrew.
- Move slides and tailstock back and forth to thoroughly clean/lubricate underneath them.
- After cleaning, wipe down ways with a high-quality way oil.



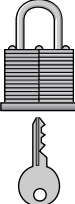
# Site Considerations

## Weight Load

Refer to the **Machine Data Sheet** for the weight of your machine. Make sure that the surface upon which the machine is placed will bear the weight of the machine, additional equipment that may be installed on the machine, and the heaviest workpiece that will be used. Additionally, consider the weight of the operator and any dynamic loading that may occur when operating the machine.

## Space Allocation

Consider the largest size of workpiece that will be processed through this machine and provide enough space around the machine for adequate operator material handling or the installation of auxiliary equipment. With permanent installations, leave enough space around the machine to open or remove doors/covers as required by the maintenance and service described in this manual. **See below for required space allocation.**

	<p><b>CAUTION</b></p> <p>Children or untrained people may be seriously injured by this machine. Only install in an access restricted location.</p>
---	--

## Physical Environment

The physical environment where the machine is operated is important for safe operation and longevity of machine components. For best results, operate this machine in a dry environment that is free from excessive moisture, hazardous chemicals, airborne abrasives, or extreme conditions. Extreme conditions for this type of machinery are generally those where the ambient temperature range exceeds 41°–104°F; the relative humidity range exceeds 20%–95% (non-condensing); or the environment is subject to vibration, shocks, or bumps.

## Electrical Installation

Place this machine near an existing power source. Make sure all power cords are protected from traffic, material handling, moisture, chemicals, or other hazards. Make sure to leave enough space around machine to disconnect power supply or apply a lockout/tagout device, if required.

## Lighting

Lighting around the machine must be adequate enough that operations can be performed safely. Shadows, glare, or strobe effects that may distract or impede the operator must be eliminated.

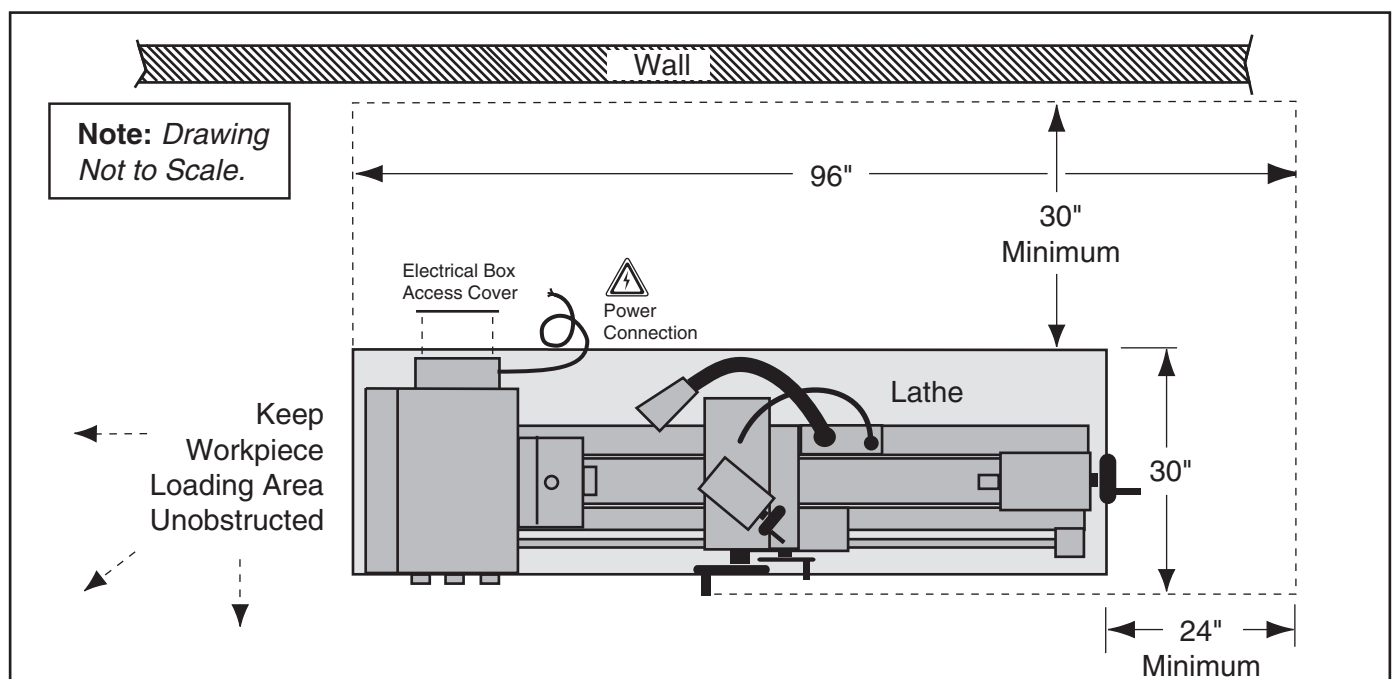
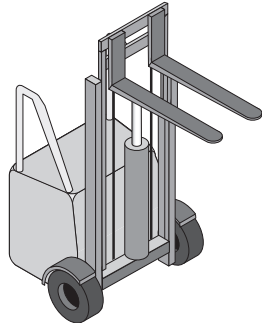


Figure 6. Minimum working clearances.



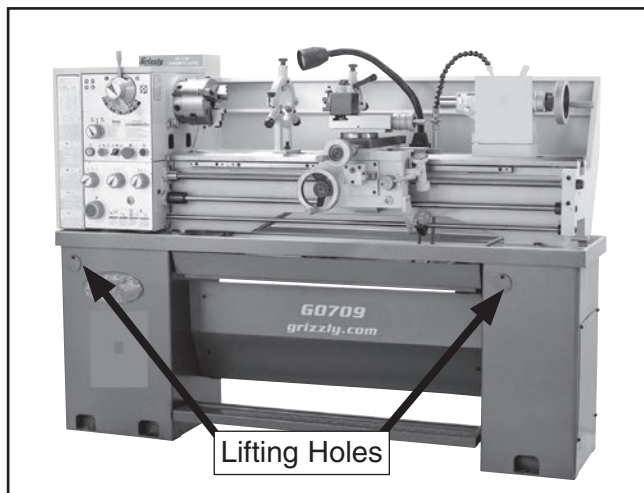
# Lifting & Moving

## **⚠️ WARNING**



**You must use power lifting equipment and assistance to lift and move this machine. Inspect all lifting equipment to make sure it is in working order and rated for the load before attempting to lift. Ignoring this warning may lead to serious personal injury or death.**

This lathe has a hole built into each end of the stand (see **Figure 7**) that is designed to accept a sturdy 1" diameter lifting bar. Each bar must extend far enough from the stand so that chains or lifting straps can be looped or connected to all four corners and the lathe can be lifted.



**Figure 7.** Lifting holes.

# Anchoring to Floor

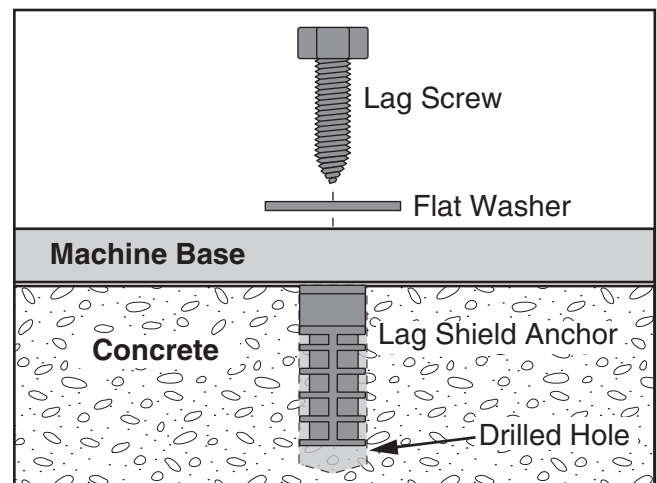
Anchoring machinery to the floor prevents tipping or shifting and reduces vibration that may occur during operation, resulting in a machine that runs slightly quieter and feels more solid.

If the machine will be installed in a commercial or workplace setting, or if it is permanently connected (hardwired) to the power supply, local codes may require that it be anchored to the floor.

If not required by any local codes, fastening the machine to the floor is an optional step. If you choose not to do this with your machine, we recommend placing it on machine mounts, as these provide an easy method for leveling and they have vibration-absorbing pads.

## Anchoring to Concrete Floors

Lag shield anchors with lag screws (see below) are a popular way to anchor machinery to a concrete floor, because the anchors sit flush with the floor surface, making it easy to unbolt and move the machine later, if needed. However, anytime local codes apply, you **MUST** follow the anchoring methodology specified by the code.



**Figure 8.** Popular method for anchoring machinery to a concrete floor.



## Leveling

---

### **NOTICE**

For accurate turning results and to prevent warping the cast iron bed and ways, the lathe bedways **MUST** be leveled from side-to-side and from front-to-back on both ends.

Re-check the bedways 24 hours after installation, two weeks after that, and then annually to make sure they remain level.

Leveling machinery helps precision components, such as bedways, remain straight and flat during the lifespan of the machine. Components on a machine that is not level may slowly twist due to the dynamic loads placed on the machine during operation.

For best results, use a precision level that is at least 12" long and sensitive enough to show a distinct movement when a 0.003" shim (approximately the thickness of one sheet of standard newspaper) is placed under one end of the level.

See the figure below for an example of a high precision level.

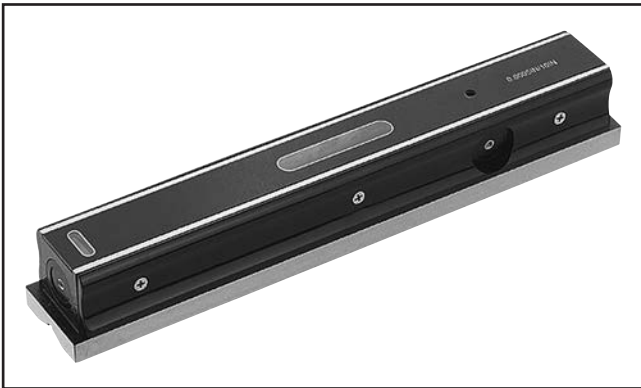


Figure 9. Model H2683 precision level.

## Lubricating Lathe

---

It is critical that there is oil in the headstock, quick change gearbox, and the apron gearbox before proceeding with the test run. Refer to the **Lubrication** instructions on **Page 54** for more details on which type and how much oil to use in each gearbox.



## Adding Cutting Fluid

---

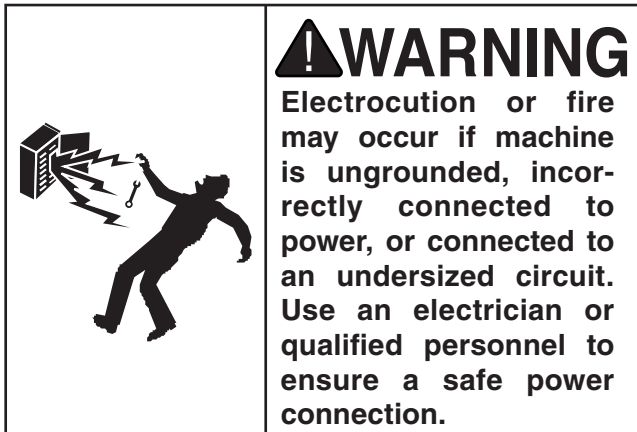
For detailed instructions on where the cutting fluid tank is located and how to add fluid, refer to **Cutting fluid System** on **Page 56**.





# Power Connection

---



Once all preparation steps previously described in this manual have been completed, the machine can be connected to the power source. In order to be connected to the power source, a circuit must be installed/prepared that meets the requirements of the lathe, and a power connection method must be established for that circuit.

Using an incorrectly sized cord causes machine electrical components and the cord to become very hot, which can lead to component failure or result in fire. For best results, use the shortest length of cord possible, and never use a smaller cord gauge than the specified minimum.

# Test Run

---

Once assembly is complete, test run the machine to make sure it runs properly and is ready for regular operation. The test run consists of verifying the following: 1) The motor powers up and runs correctly and 2) the stop button safety feature works correctly.

If, during the test run, you cannot easily locate the source of an unusual noise or vibration, stop using the machine immediately, then review **Troubleshooting on Page 57**.

If you cannot find a remedy, contact our Tech Support at (570) 546-9663 for assistance.

## To begin the test run:

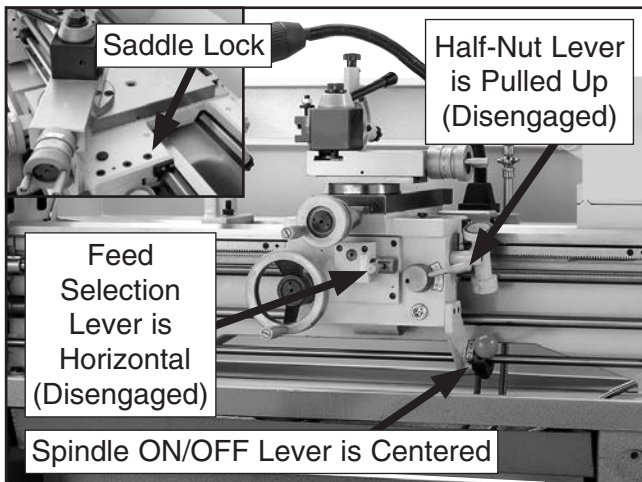
1. Make sure you understand the safety instructions at the beginning of the manual and that all previous setup sections have been completed.
2. Make sure the lathe is lubricated and the oil levels are at the full mark. Refer to **Maintenance on Page 52** for details.
3. Make sure the chuck is correctly secured to the spindle. Refer to **Chuck and Faceplate Mounting on Page** for detailed installation instructions.
4. Make sure all tools and objects used during setup are cleared away from the machine.



# NOTICE

**NEVER** shift lathe gears when lathe is operating, and make sure both the half-nut lever and the feed selection lever are disengaged before you start the lathe! Otherwise the carriage may feed into the chuck or tailstock and cause severe damage.

5. Disengage the half-nut lever and the feed selection lever (see **Figure 10**), and make sure the saddle lock is loosened to allow the lead screw or feed rod to move the apron if required.



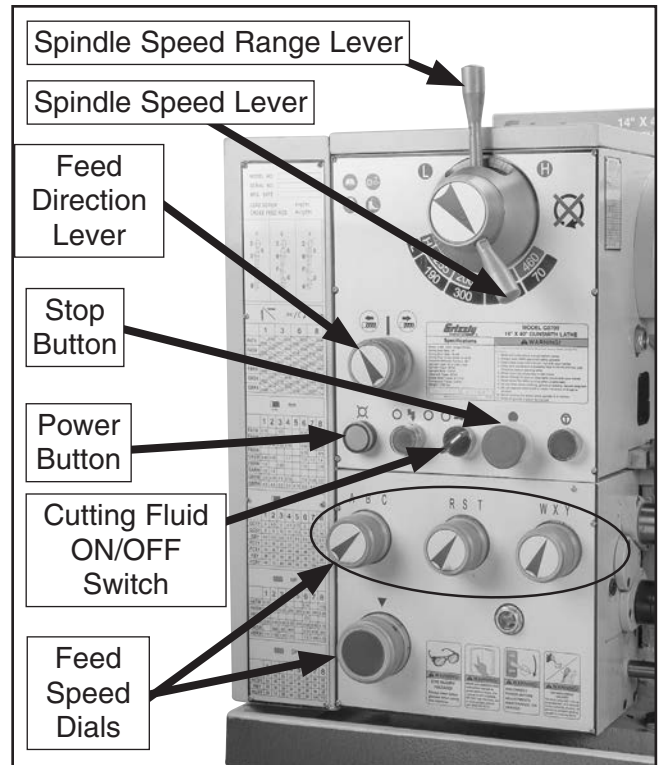
**Figure 10.** Apron controls.

6. Make sure the cutting fluid pump switch is **OFF**, point the cutting fluid nozzle into the lathe chip pan.

# WARNING

**Before starting the lathe, make sure you have performed any preceding assembly and adjustment instructions, and you have read through the rest of the manual and are familiar with the various functions and safety features on this machine. Failure to follow this warning could result in serious personal injury or even death!**

7. Rotate the stop button (**Figure 11**) clockwise until it pops out.
8. Move the feed direction lever (see **Figure 11**) to the disengaged middle position.



**Figure 11.** Headstock controls.

9. Move the spindle speed range lever to the "L" position and move the spindle speed lever to the "70" position.

**Note:** As long as the feed direction lever shown in **Figure 11** is disengaged, no torque will be transmitted to the quick change gearbox or any other gear-driven component. As a result, the feed speed dials shown in **Figure 11** can be left engaged or disengaged for the test run.

10. Push the power button (see **Figure 11**), then move the spindle ON/OFF lever (see **Figure 10**) downward to start the lathe. The spindle will rotate at 70 RPM.

—If the top of the chuck is rotating toward you, the lathe motor is rotating in the correct direction. Continue to the next **Step**.

—If the top of the chuck is rotating away from you, reverse the motor rotation. Refer to the **Motor Wiring** diagram on **Page 75**, and follow the **NOTICE** on that page.

—When operating correctly, the machine runs smoothly with little or no vibration or rubbing noises.





—Investigate and correct strange or unusual noises or vibrations before operating the machine further. Always disconnect the machine from power when investigating or correcting potential problems. If the problem is not readily apparent, refer to **Troubleshooting** on **Page 57**.

11. Move the spindle ON/OFF lever up to the center position, and press the stop button.
12. WITHOUT resetting the stop button, move the spindle ON/OFF lever down. The machine should not start.

—If the machine does not start, the stop button safety feature is working correctly. Continue to the next **Step**.

—If the machine starts (with the stop button pushed in), immediately disconnect power to the machine. The stop button safety feature is not working correctly. This safety feature must work properly before proceeding with regular operations. Call Tech Support for help.

13. Rotate the stop button clockwise until it pops out.
14. Make sure the lamp works.
15. Make sure that the cutting fluid nozzle is pointing toward the chip pan, then turn the cutting fluid pump switch **ON**, and open the nozzle valve. After verifying that cutting fluid flows from the nozzle, turn the cutting fluid switch **OFF**.16. Start the spindle, then step on the brake pedal. The power to the motor should be cut and the spindle should come to an immediate stop.



# Spindle Break-In

---

Before subjecting the spindle to operational loads, it is essential to complete the break-in process. This helps maximize the life of spindle bearings and other precision components by thoroughly lubricating them before placing them under load.

After spindle break-in is complete, we recommend changing headstock and gearbox oil to remove any metal particles or debris that are present from the assembly and break-in process.

The break-in must be performed in succession with the **Test Run** procedure described in this manual, as the steps in that procedure prepare the lathe controls for the break-in process.

## **NOTICE**

**DO NOT perform this procedure independently of the Test Run section. The lathe could be seriously damaged if the controls are set differently than instructed in that section.**

### **To perform the spindle break-in:**

1. Successfully complete the **Test Run** procedure beginning on **Page 19**.
2. Disengage the half-nut lever and the feed selection lever.
3. Run the spindle at 70 RPM for 10 minutes each in direction (first forward and then reverse).
4. Repeat running the lathe in this manner through the rest of the spindle speeds, progressively increasing in RPM.
5. Press the stop button and **DISCONNECT THE LATHE FROM POWER!** The lathe is broken in.

Congratulations! Spindle break-in is complete. We recommend changing the headstock and gearbox oil before operating the machine further (refer to **Lubrication** on **Page 54**).

# Recommended Adjustments

---

For your convenience, the adjustments listed below have been performed at the factory.

However, because of the many variables involved with shipping, we recommend that you at least verify the following adjustments to ensure the best possible results from your new machine.

Step-by-step instructions for these adjustments can be found in the **SERVICE** section starting on **Page 57**.

### **Factory adjustments that should be verified:**

- Verify Three-Jaw Chuck Registration in **Chuck and Faceplate Removal/Installation (Page 27)**
- Camlock Stud Installation (**Page 29**)
- Gib Adjustments (**Page 59**)
- Tailstock Alignment (**Page 36**)
- Backlash Adjustment (**Page 61**)

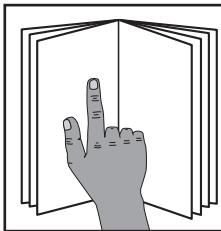


# SECTION 4: OPERATION

## Operation Overview

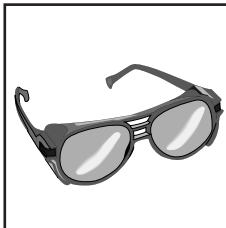
The purpose of this overview is to provide the novice machine operator with a basic understanding of how the machine is used during operation, so the machine controls/components discussed later in this manual are easier to understand.

Due to the generic nature of this overview, it is **not** intended to be an instructional guide. To learn more about specific operations, read this entire manual, seek additional training from experienced machine operators, and do additional research outside of this manual by reading "how-to" books, trade magazines, or websites.



### **!WARNING**

To reduce your risk of serious injury, read this entire manual **BEFORE** using machine.



### **!WARNING**

To reduce the risk of eye injury from flying chips always wear safety glasses.

### **NOTICE**

If you are not experienced with this type of machine, **WE STRONGLY RECOMMEND** that you seek additional training outside of this manual. Read books/magazines or get formal training before beginning any projects. Regardless of the content in this section, Grizzly Industrial will not be held liable for accidents caused by lack of training.

To complete a typical operation, the operator does the following:

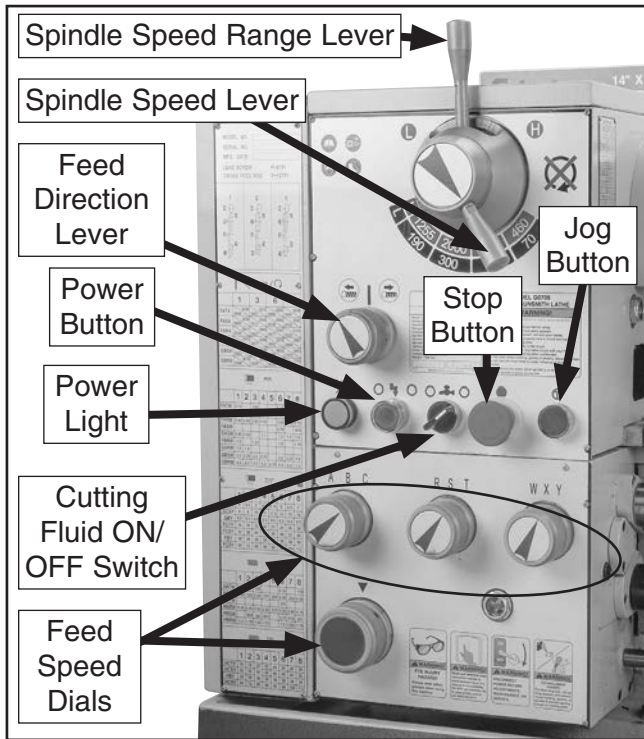
1. Puts on safety glasses, rolls up sleeves, removes jewelry, and secures any clothing, jewelry, or hair that could get entangled in moving parts.
2. Examines the workpiece to make sure it is suitable for turning, then mounts the workpiece required for the operation.
3. Mounts the tooling, aligns it with the workpiece, then adjusts it for a safe startup clearance.
4. Clears all tools from the lathe.
5. Sets the correct spindle speed for the operation.
6. Checks for safe clearances by rotating the workpiece by hand one full revolution.
7. Moves slides to where they will be used during operation. If using power feed, selects the proper feed rate for the operation.
8. Turns the main power switch **ON**, resets the stop button so it pops out, then moves the spindle ON/OFF lever down to start spindle rotation. The spindle will rotate forward (the top of the chuck rotates toward the operator).
9. Uses the carriage handwheels or power feed options to move the tooling into the workpiece for operations.
10. **When finished cutting, moves the ON/OFF lever** to the center position to turn the lathe **OFF**, then removes the workpiece.



# Controls

## Headstock Controls

Use the descriptions in this section and the controls shown in **Figure 12** to quickly understand the functions of the headstock and quick change gearbox controls, and to find their locations on the lathe.



**Figure 12.** Headstock controls.

### **Spindle Speed Range Lever**

Alternately engages drive gears to produce high or low range operation in the headstock.

### **Spindle Speed Lever**

Controls the spindle speed only and has no effect on the gearbox speed or the apron feeds.

### **Feed Direction Lever**

Controls the forward and reverse direction of the carriage and cross feed. When this lever moved left or right, the direction of the quick change gearbox, feed rod, and lead screw reverse direction, but spindle direction is unaffected.

### **Power Light**

When the lathe is connected to power, it is not necessarily ready for use. Only when the stop button is twisted clockwise and popped-out, and the ON button has been pushed will the power light illuminate and indicate that all electrical controls are "LIVE" and ready for use. Just because the power light is OFF, do not assume that the lathe is safe for electrical work, general adjustments, or workpiece changes. You must always disconnect the lathe from power before attempting any of these tasks.

### **Power Button**

Prevents accidental start up. Every time the stop button is pressed in and then reset, the power button must be pressed. If there has been a power outage while the lathe was operating, when power is resumed, the power button must be pressed to reactivate the power to the control panel. If the foot brake is pressed, a limit switch will cut power to the motor immediately.

### **Cutting fluid ON/OFF Switch**

Toggles the cutting fluid pump **ON** or **OFF**. Never turn the cutting fluid pump on and let it run while the reservoir is empty, or pump damage may occur.

### **Feed Speed Dials**

Engage either the feed rod or leadscrew, and set the apron speed for threading, turning, or facing operations.

### **Stop Button**

Cuts power to the spindle motor and the control panel. No braking occurs and the spindle, chuck, and workpiece wind-down naturally. After being pressed, the stop button stays pushed in until it is reset by twisting the knob clockwise until it pops back out.

### **Jog Button**

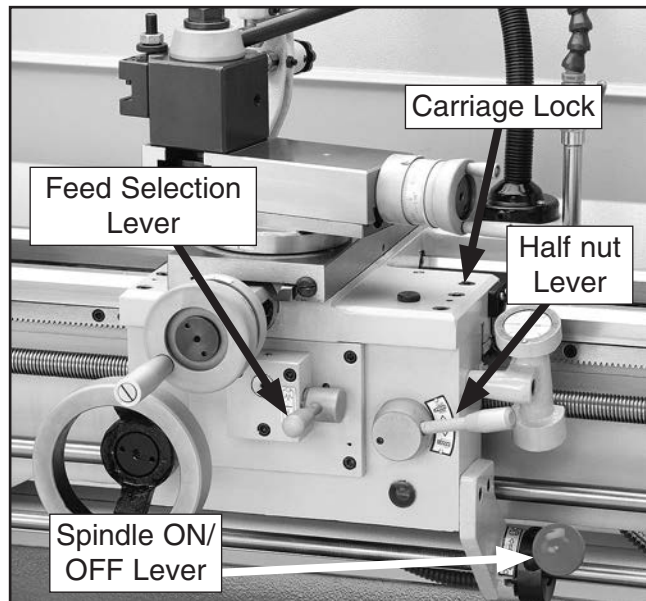
Bumps the motor **ON** and **OFF** so partial spindle rotation occurs in reverse. Useful when the lathe is stopped in low range and the lathe gear reduction makes it difficult for the machinist to rotate the chuck by hand in order to reposition a chuck or workpiece.

**Note:** In order to use the jog button, the Spindle ON/OFF lever must be in the central or **OFF** position.



## Apron Controls

Use the descriptions in this section and the controls shown in **Figure 13** to quickly understand the functions of the apron and its related controls.



**Figure 13.** Carriage lever controls.

### ***Spindle ON/OFF Lever***

Starts and stops the spindle in forward and reverse.

- Moving the lever downward from the central OFF position spins the chuck forward (the top of the chuck moves toward the machinist).
- Moving the lever upward from the central OFF position spins the chuck in reverse (the top of the chuck moves away from the machinist).

### ***Feed Selection Lever***

Allows the machinist to engage or disengage the apron for longitudinal or cross feeding tasks.

### ***Carriage Lock***

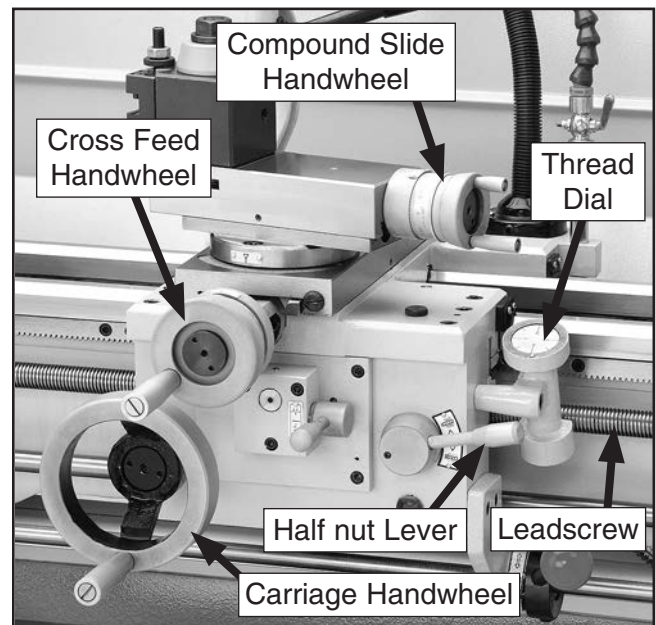
Clamps the right front of the saddle to the lathe way for increased rigidity when facing a workpiece.

### ***Half-Nut Lever***

Clamps the halfnut to the leadscrew for inch-threading operations.

### ***Thread Dial***

Avoids cross-cutting inch threads by indicating to the machinist where to re-clamp the half nut in order to resume threading after a carriage return.



**Figure 14.** Apron controls.

### ***Carriage Handwheel***

For moves the carriage longitudinally left or right along the ways.

### ***Cross Slide Handwheel***

Moves the cross slide in or out perpendicular to carriage travel and is equipped with a "Standard Dial" that has a ratio of 1:2.

### ***Compound Slide Handwheel***

Moves the compound and cutting tool relative to the workpiece at various angles with fine-depth control.

### ***Compound Slide Scale***

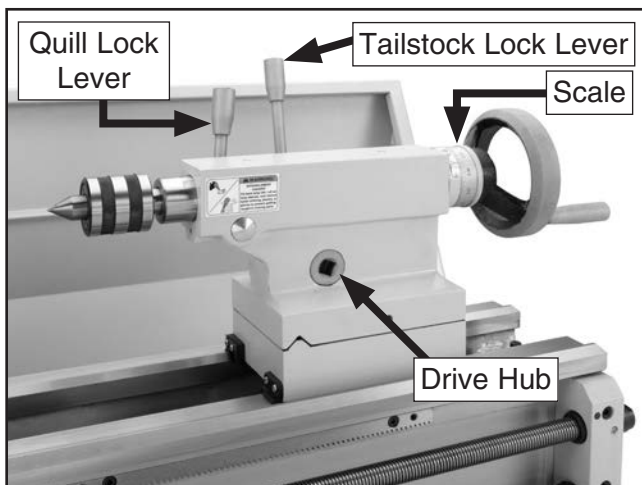
The 110° rosette on the top of the compound indicates compound angles. Zero splits the scale into two ranges, 55° to the right and 55° to the left in 1° degree increments.





## Tailstock

Use the descriptions in this section and the controls shown in **Figure 15** to quickly understand the functions of the tailstock controls.



**Figure 15.** Tailstock controls.

### ***Quill Lock Lever***

Secures the quill in a locked or pre-loaded position.

### ***Tailstock Lock Lever***

Clamps the tailstock in place for general position locking along the lathe bed.

### ***Drive Hub***

Allows the tailstock to be locked in place using a 1/2" drive torque wrench to control amount of draw-down alignment with the spindle centerline.

### ***Tailstock Handwheel***

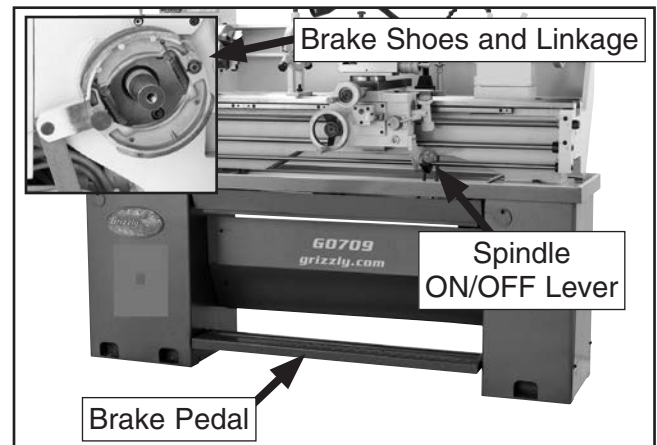
Advances or retracts the quill in the tailstock at a 1:1 ratio with the micrometer scale on the handwheel hub.

### ***Micrometer Scale***

Displays quill travel in increments of 0.001" with a total rotation value of 0.100", (for every full rotation of the handwheel, the quill moves 1/10"). The tailstock quill is broken down with an inch scale up to 4" and a metric scale up to 100mm.

## Brake

When pressed, the brake pedal (see **Figure 16**) actuates mechanical linkage that expands brake shoes within the spindle drive pulley and stops the lathe spindle. At the same time the motor power supply circuit is cut by a linkage-controlled limit switch. To resume lathe operations after the brake has been used, return the spindle ON/OFF lever to the central position, and all lathe controls become "LIVE" again.

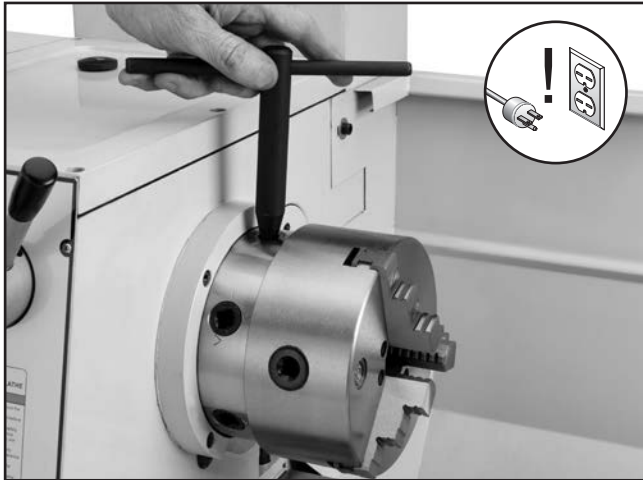


**Figure 16.** Spindle brake system.



# Chuck & Faceplate Removal/Installation

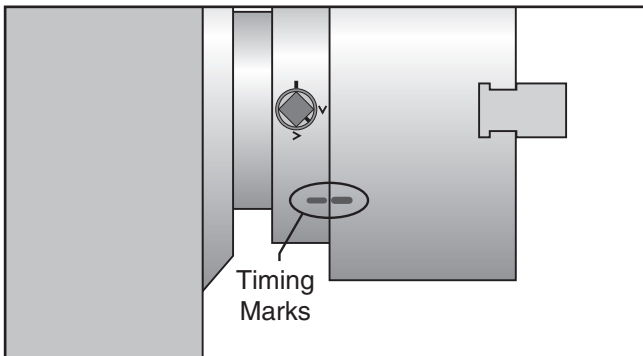
This lathe is shipped with a 3-jaw chuck installed, but also includes a 4-jaw chuck and 12" faceplate. The chucks and faceplate mount to the spindle with a D1-5 camlock system, which uses a key to loosen and tighten camlocks for removal or installation (see **Figure 17**).



**Figure 17.** Chuck key positioned to remove a typical camlock mounted chuck.

Before the 4-jaw chuck and faceplate can be installed on the spindle, their respective cam studs must be installed and adjusted.

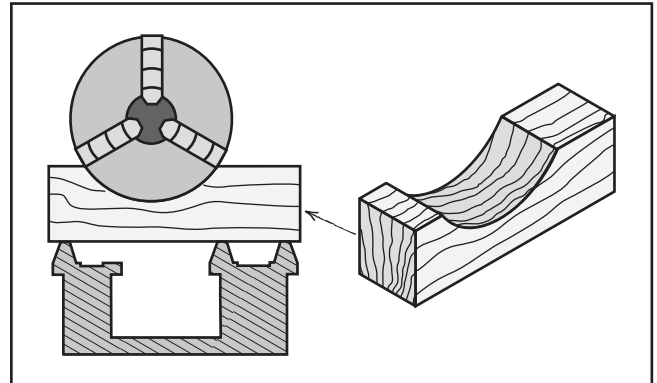
To maintain consistent removal and installation of the chucks and faceplate, each should have a timing mark that can be lined up with a matching one on the spindle, so it will be installed in the same position every time (see **Figure 18**). Before removing the 3-jaw chuck, verify that a timing mark exists. If a mark cannot be found, stamp your own on both the chuck and spindle.



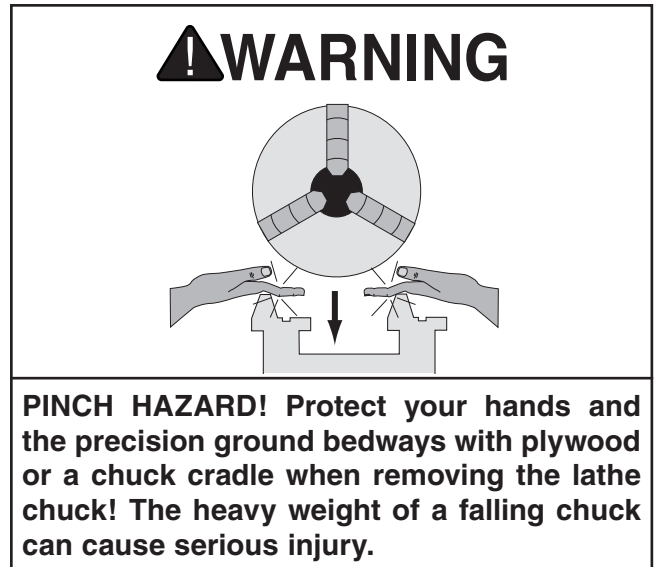
**Figure 18.** Chuck/spindle timing marks.

## Chuck & Faceplate Removal

1. DISCONNECT LATHE FROM POWER!
2. Lay a chuck cradle (see **Figure 19**) or a layer of plywood over the bedways to protect the precision ground surfaces from damage and to prevent fingers from being pinched.



**Figure 19.** Simple chuck cradle made of scrap lumber.

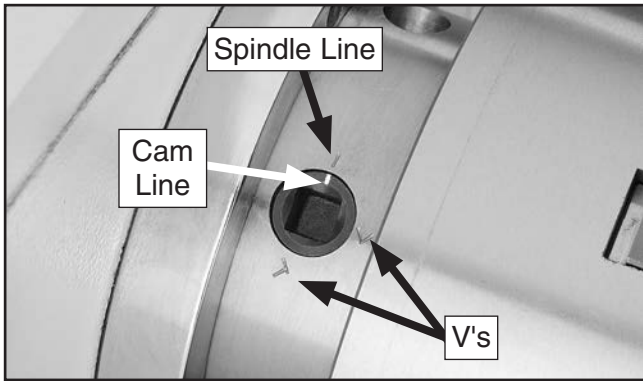


3. Loosen the cam-locks by turning the key counterclockwise approximately one-third of a turn until the mark on the cam-lock aligns with the single mark on the spindle nose in **Figure 20**. If the cam-lock stud does not freely release from the cam-lock, wiggle the cam-lock until the cam-lock stud releases.

**Note:** These cam-locks may be very tight. A breaker bar may be used to add leverage.







**Figure 20.** Indicator arrows.

4. Using a dead blow hammer or other soft mallet, lightly tap around the outer circumference of the chuck body to break the chuck free from the cam-locks and from the spindle nose taper.

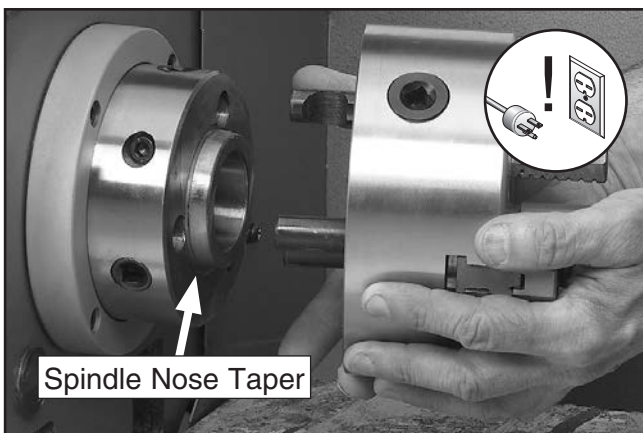
**CAUTION:** The chuck may come off at this point, so it is important you are ready to support its weight.

**⚠ WARNING**

Large chucks are very heavy. Always get assistance when removing or installing large chucks to prevent personal injury or damage to the chuck or lathe.

5. Use a rocking motion to carefully remove the chuck from the spindle (see **Figure 21**).

—If the chuck does not immediately come off, rotate the spindle approximately 60° and tap again. Make sure all the marks on the cams and spindle are in proper alignment.



**Figure 21.** Installing and removing a typical camlock style chuck.

## Chuck & Faceplate Installation

1. DISCONNECT LATHE FROM POWER!
2. Place a piece of plywood across the lathe ways just under the chuck, and use a chuck cradle if desired.
3. Make sure the chuck taper and spindle taper mating surfaces are perfectly clean.
4. Inspect and make sure that all camlock studs are undamaged, are clean and lightly oiled, and that the camlock stud cap screws are in place and snug.

—If the camlock studs have not yet been installed in the chuck or faceplate, complete the **Camlock Stud Installation** on the next page.

### **NOTICE**

Never install a chuck or faceplate without having the camlock cap screws in place or fully tightened. If you ignore this notice, once installed the chuck may never be able to be removed since the camlock studs will turn with the camlocks and never release.

5. Align the chuck-to-spindle timing marks (see **Figure 23**), and slide the chuck onto the spindle.
6. Turn a camlock with the chuck wrench until the cam mark falls between the "V" marks as shown in **Figure 22**.

—If the cam lock mark stops outside of the "V" marks, remove the chuck and adjust the cam stud height of the offending studs one full turn up or down (see **Figure 22**).



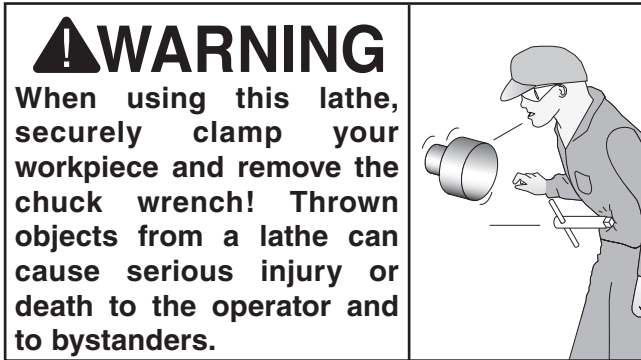
**Figure 22.** Cam-lock in the locked position.



- Lock the other cams in a star pattern so the chuck is drawn up evenly on all sides without any chance of misalignment.

**Note:** If any of the cam lock marks (see **Figure 23**) do not fall between the "V" marks when the cam lock is tight, you must adjust the offending camlock stud as discussed in **Camlock Stud Installation**.

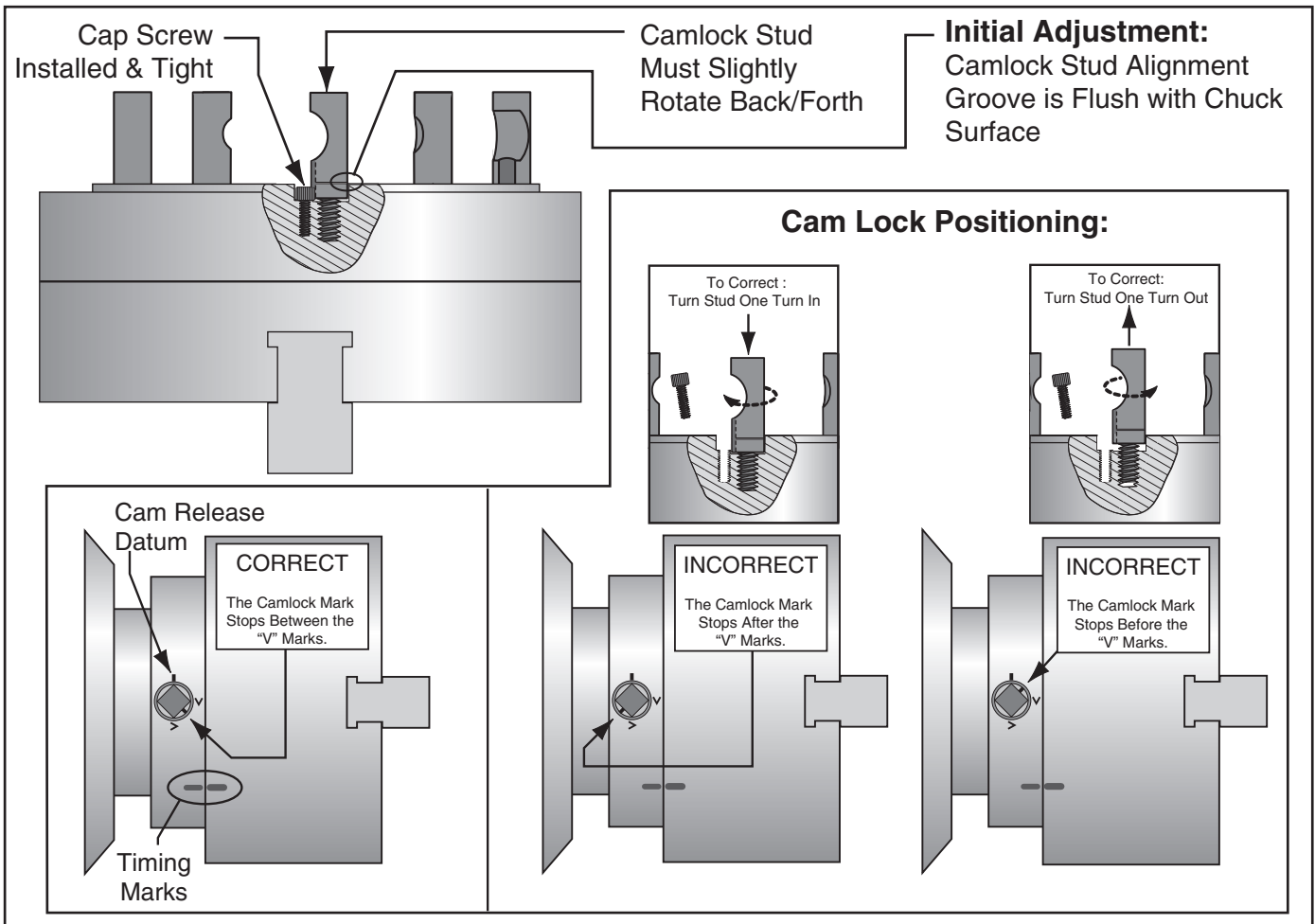
- Remove the chuck wrench.



## Camlock Stud Installation

- Oil and thread each cam stud into the chuck until the alignment groove is flush with the chuck surface as shown in **Figure 23**.
- Install and tighten the locking cap screw for each stud, making sure that the camlock studs can slightly rotate back and forth.
- Place the chuck onto the spindle and tighten the cam locks in an alternating manner to avoid cocking the chuck on the spindle. When tightened:

- If the cam lock mark stops outside of the "V" marks, remove the chuck and adjust the cam stud height of the offending studs one full turn (see **Figure 23**).
- If the final position of each cam mark is between the two "V" marks as shown in **Figure 23**, no stud adjustment is required.



**Figure 23.** Camlock stud alignment.



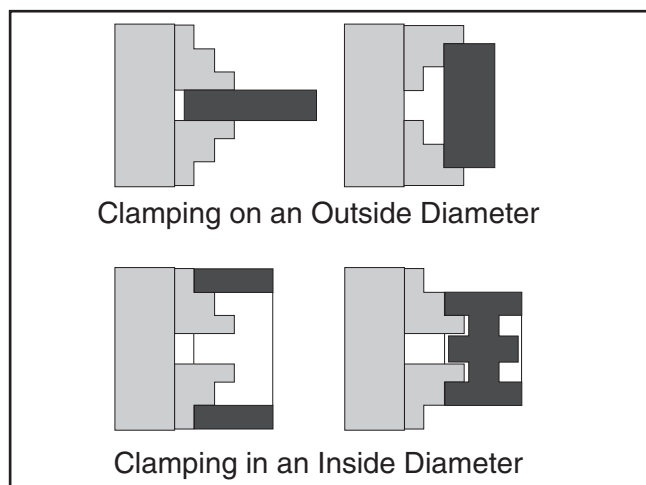
# Three-Jaw Chuck

This section outlines basic operation safety related to using the 3-jaw chuck included with your lathe. Use knowledge of safety and common sense when applying the steps on how to use this chuck. If you have any questions, feel free to contact our Technical Support Department.

The 3-jaw chuck shipped with this lathe has a two-piece reversible jaw design. An internal scroll-gear, moves all jaws in unison when adjusted. This chuck will hold cylindrical parts on-center with the axis of spindle rotation, and can be spun at high speeds if the workpiece is properly clamped and is balanced. If a workpiece must be held from the inside, rotate all three of the two-piece jaws 180° so the orientation of all jaws match. **Otherwise the chuck will spin out of balance and create an extreme thrown workpiece hazard!**

## Reversing Jaw Positions & Clamping a Workpiece

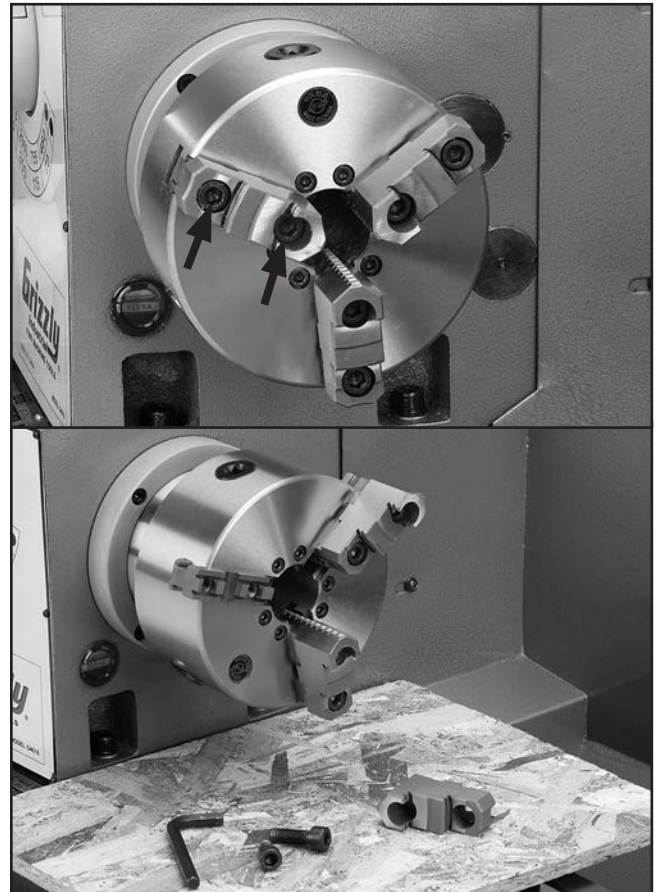
**Figure 24** shows a typical example of clamping options available with a 3-jaw chuck. The chuck included with this lathe has reversible jaws, which means the lower jaw or master jaw do not need to be removed to reverse the jaw position. Instead, the top jaw is fastened to the master jaw with cap screws that when removed allow for top jaw reversal. It is a good practice to keep the top jaws matched with their original master jaw, to ensure maximum quality of alignment and exact fit.



**Figure 24.** Three-jaw chuck OD & ID clamping.

To use the 3-jaw chuck:

1. DISCONNECT LATHE FROM POWER!
2. Remove the cap screws that retain the top portion of one of the jaws (see **Figure 25**), and remove the jaw.



**Figure 25.** Reversing the chuck jaws.

3. Making sure the longer cap screw remains in the thicker part of the jaw, rotate the jaw 180° and re-install it to the lower jaw (see **Figure 25**).
4. Repeat **Steps 2–3** on the remaining jaws

<p><b>⚠ WARNING</b> Always securely tighten jaws and remove all tools from the lathe before starting spindle! Thrown objects from a lathe can cause serious injury or death to the operator and to bystanders.</p>	
--	--



# Four-Jaw Chuck

This section outlines basic operation safety related to using the 4-jaw chuck included with your lathe. Use knowledge of safety and common sense when applying the steps on how to use this chuck. If you have any questions, feel free to contact our Technical Support Department.

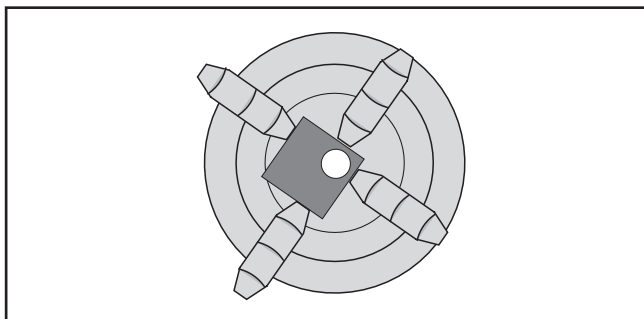
Select this chuck for low-speed lathe operations only. The 4-Jaw chuck uses independently adjustable jaws, meaning each is adjusted by an individual worm gear. Non-cylindrical parts can be held and brought into the spindle centerline for facing or boring. The other benefit is that the majority of a workpieces can be positioned out of the spindle rotation axis if a bore or step needs to be cut into a workpiece on an outlying edge.

For the best grip possible on odd-shaped workpieces, one or more jaws can also be rotated 180° to grab more surface area for clamping.

If all four jaws cannot be used to hold the workpiece, you must use the faceplate for improved clamping options. Otherwise, a severe out-of-balance condition will be created. If spun even at an average speed, this chuck will almost always be out of balance, and the machinist and bystanders will be at risk of being hit with a thrown workpiece. Being hit by an ejected workpiece can be fatal.

## Reversing Jaw Positions & Clamping a Workpiece

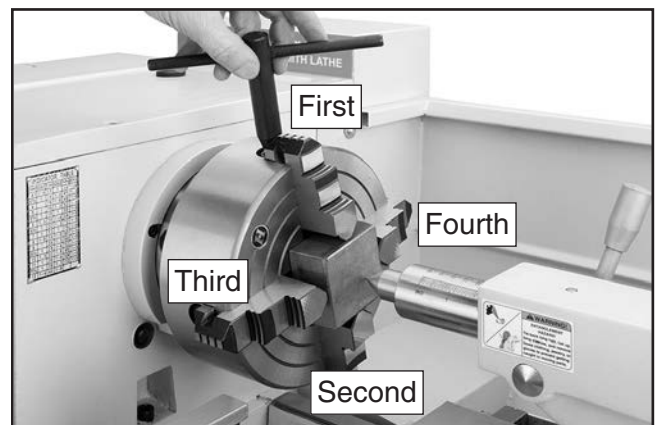
Shown in **Figure 26** is an example of the independent jaws holding a non-cylindrical workpiece for off-center boring. One or more jaws can be reversed in any combination to get the best grip on the workpiece.



**Figure 26.** Four-jaw chuck independent jaw-clamping with two jaws reversed.

## To use the 4-jaw chuck:

1. DISCONNECT LATHE FROM POWER!
2. Install a center in the tailstock.
3. Open each jaw with the chuck wrench and place the workpiece flat against the chuck face.
4. Support the workpiece and slide the tailstock forward so the tip of the dead center presses against the workpiece. Next, lock the tailstock in position. For more information, refer to the tailstock controls on **Page 65** and **Centers** on **Page 33**.
5. Turn the tailstock quill so the dead center applies enough pressure to the center point of your workpiece to hold it in place (see **Figure 27**), then lock the tailstock quill.



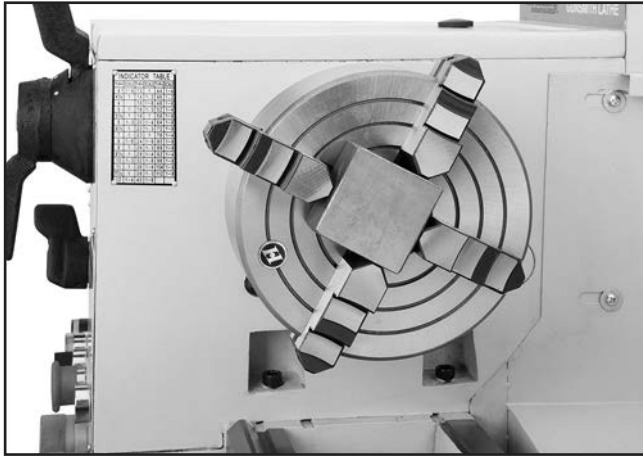
**Figure 27.** Centering workpiece (tool post removed for clarity).

6. Turn each jaw until it just makes contact with the workpiece.
7. Tighten each jaw in small increments. After adjusting the first jaw, continue tightening in opposing sequence (see **Figure 27**). Check frequently to make sure the required point on the workpiece has not wandered away from the spindle centerline due to applying too much pressure to a single jaw.





- After the workpiece is held in place, back the tailstock away and rotate the chuck by hand. The center point will move if the workpiece is out of center (see **Figure 28**).



**Figure 28.** Properly held workpiece for low speed offset boring or machining.

- Make fine adjustments by slightly loosening one jaw and tightening the opposing jaw until the workpiece is held securely and precisely aligned with the spindle centerline.

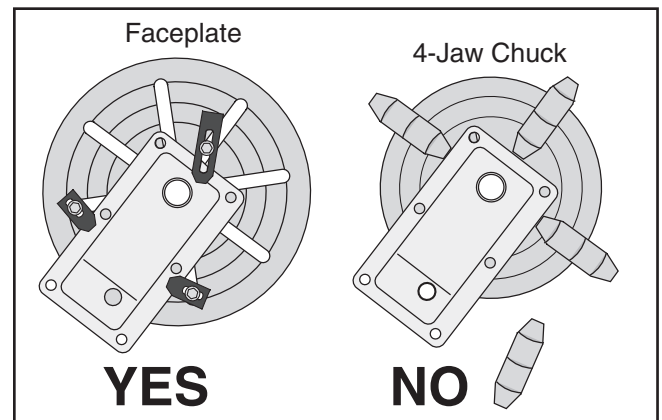
## Faceplate

This section outlines basic operation safety related to using the faceplate included with your lathe. Use knowledge of safety and common sense when applying the steps on how to use this faceplate. If you have any questions, feel free to contact our Technical Support Department.

The faceplate is cast-iron and has multiple slots for T-bolts that hold clamping hardware. If you suspect that any of the chuck or jaw combinations may not hold a workpiece safely, remove the chuck and install the faceplate as outlined for special clamping options.

**However, just as with the 4-Jaw chuck, not all workpieces can be safely held. Holding a workpiece off center or holding an irregular-shaped workpiece will cause the entire assembly to rotate out of balance. If spun at any speed higher than low, the workpiece can eject hitting the lathe operator or bystanders causing a severe or fatal injury.**

**Figure 29** shows an example of a workpiece being improperly held with the 4-jaw chuck. One jaw of the chuck interfered with the workpiece edge, and removing the jaw creates an extreme workpiece ejection hazard. The workpiece holding solution shown in **Figure 29** is to use the faceplate with a minimum of three clamps that are spaced as equally apart as possible for full support.

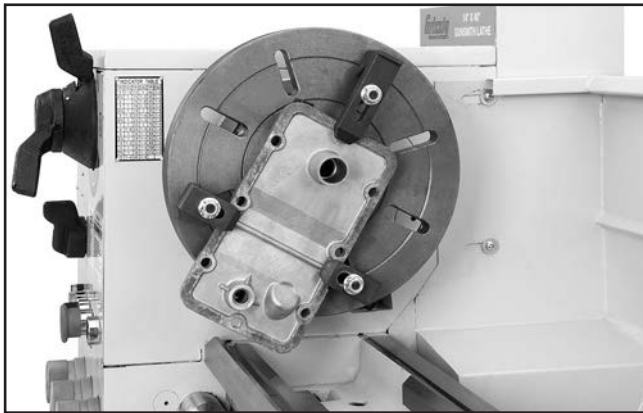


**Figure 29.** Workpiece to faceplate clamping.



## To use the faceplate:

1. DISCONNECT LATHE FROM POWER!
2. Insert a dead center into the tailstock, slide the tailstock up to the faceplate, and lock the tailstock into position.
3. Place the workpiece against the faceplate and turn the tailstock quill so the point of the dead center touches and applies enough pressure to hold the workpiece in place.
4. Lock the quill when sufficient pressure is applied to hold the workpiece. Additional support may be needed, depending on the workpiece.
5. Clamp the workpiece at a minimum of three locations that are as close to being evenly spaced apart as possible as shown in **Figure 30**.



**Figure 30.** Workpiece properly clamped on the faceplate in a minimum of three locations (tailstock removed for clarity).

## **!**WARNING

**Use a minimum of three independent clamping devices when using faceplate. Failure to provide adequate clamping may cause workpiece to eject during operation.**

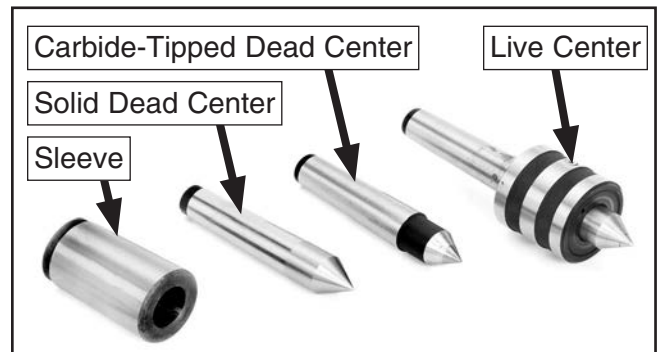
6. Double check for safety and rotation clearance.
7. Slide the tailstock away from the workpiece and install the required tailstock tooling for drilling or boring, or position the tool bit for facing.



# Centers

The Model G0709 lathe is supplied with two MT#3 dead centers, an MT#3 live center, and a MT#5–MT#3 adapter sleeve (see **Figure 31**) to adapt the centers into spindle bore. When installing centers verify that all mating surfaces are clean and free of nicks and burrs.

**Tip:** *Hand-held tapered bore wipers make this task very time efficient, and offer consistently clean bores.*

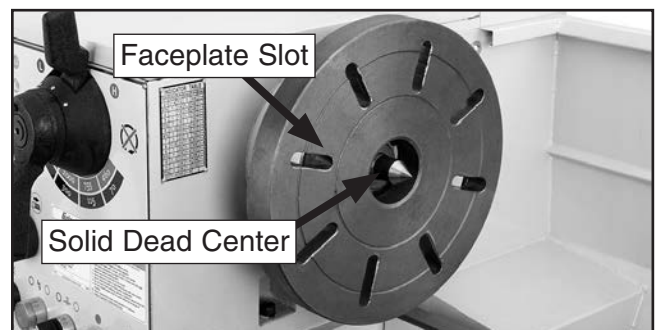


**Figure 31.** Included centers and sleeve.

## Solid Dead Center

Dead centers are typically used in low speed turning operations to increase rigidity for close tolerances. The solid dead center is installed at the spindle end of the lathe because the workpiece, center, and spindle all turn together by the use of a lathe dog. One end of the lathe dog is clamped to the workpiece, and the other end the tail, is inserted into a faceplate slot shown in **Figure 32**).

**Tip:** *If the tail is too large for a slot, install the 3-jaw chuck, open the jaws so the workpiece can be supported by the center and the tail of the dog can rest against a jaw.*



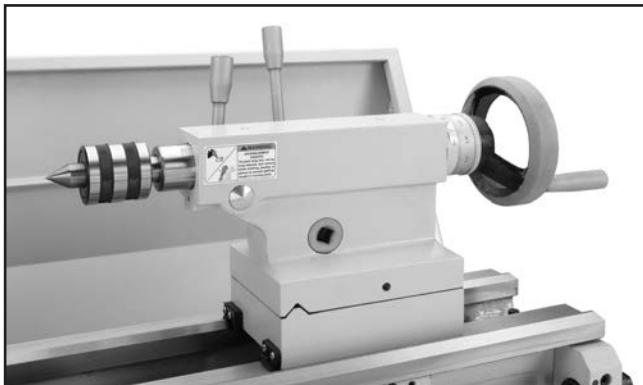
**Figure 32.** Faceplate and dead center setup.

## Carbide-Tipped Dead Center

When the workpiece is supported at the tailstock end of the lathe, the workpiece will spin on the tip of the fixed center. To eliminate the tip of the center from wearing out at this point of contact, the carbide-tipped center is used. Nevertheless, during turning operations this tip must still be lubricated vigilantly, or the workpiece will wear, resulting in increased end play and poor turning results. Typically, when using centers, the tailstock quill should be locked and protrude at least  $\frac{1}{2}$ ", but not more than 3".

## Live Center

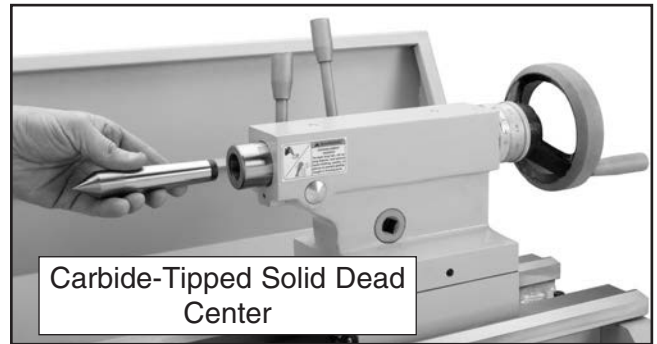
If the workpiece must be spun at higher speeds, the live center is inserted into the tailstock (see **Figure 33**). Unlike a dead center, the tip of the live center is supported with precision bearings that allow it to support and spin with the workpiece. As a result, virtually no wear occurs, and the workpiece can be turned with less concern about developing end play from tip wear. However, when using live centers, accuracy can suffer as a result of having bearings support the end of the workpiece.



**Figure 33.** Live center installed in a tailstock.

## Installing Center in Tailstock

1. Center drill the end of the workpiece to be turned or threaded.
2. Feed the quill out about 1", wipe clean and insert the center into the quill bore (see **Figure 34**). To help prevent wear, place a dab of grease on the point of the center.



**Figure 34.** Inserting a carbide-tipped dead center in the tailstock.

3. Position the tailstock so the center presses against the workpiece, then lock the tailstock in place.
4. Preload the quill into the workpiece. The force against the workpiece will fully seat the tapered center.
5. Lock the quill into place. However, keep in mind that the quill may need to be adjusted during operation to remove any play that develops between the center and the workpiece.

## Removing Center from Tailstock

To remove a center, hold the end of the center with a rag to prevent it from falling, and reverse the handwheel until the center is pressed free.

## Installing Center in Spindle

1. Install the dead center into the spindle sleeve.
2. Install the sleeve into the spindle bore.
3. Determine whether to use the chuck or faceplate, and install the required unit.
4. Clamp the required lathe dog onto the workpiece and mount the workpiece between the lathe centers.

## Removing Center from Spindle

To remove a center and sleeve, hold the end of the center with a rag to prevent it from falling, insert a wooden rod into the outboard side of the spindle, and tap the center and sleeve free.

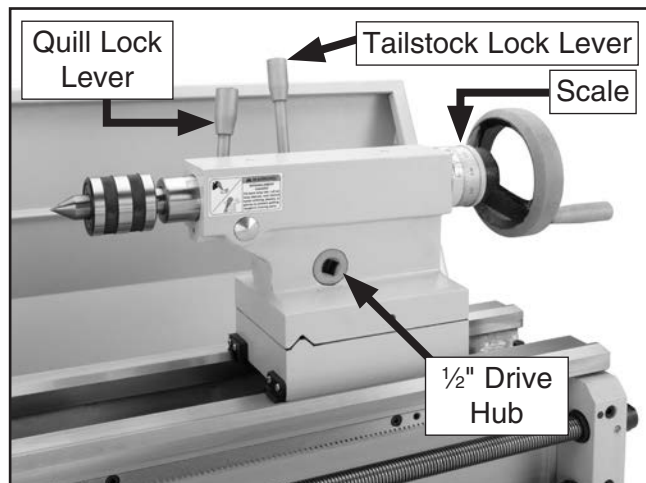




# Tailstock

## Quill Lock Lever

The quill lock lever (see **Figure 35**) secures the quill in its current position. When drilling, or when tapping operations need to be done deep into a part, the quill can also be stabilized by slightly applying the lever to add drag and preload to the quill.



**Figure 35.** Tailstock controls.

## Tailstock Lock Lever

When clamped in place, the forces draw a tailstock down into alignment with the spindle centerline. This distance is usually a few thousandths of an inch. When a tailstock lock lever is tightened by hand, the clamping pressure and tailstock alignment can be inconsistent. To eliminate this situation, a 1/2" drive ft/lb torque wrench can be inserted into the lock lever drive hub (see **Figure 35**). The tailstock then can be clamped in place at a pre-determined torque setting. As a result, all lathe operators can rely on the same draw-down alignment.

## Tailstock Handwheel

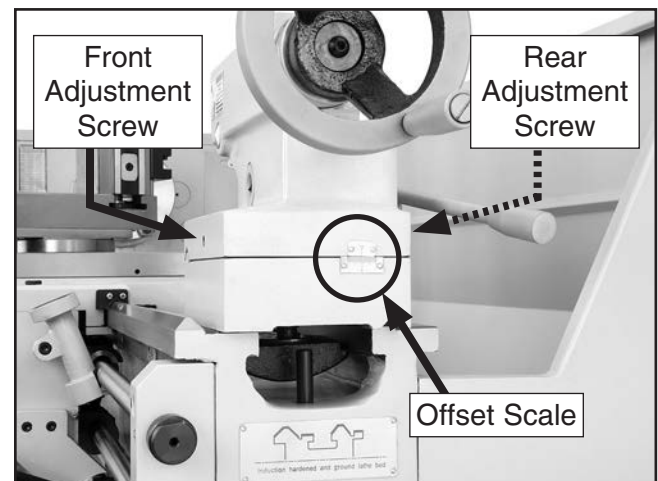
The tailstock handwheel includes a micrometer collar in increments of 0.001"–0.100". Rotating the handwheel moves the quill at a 1:1 ratio with the collar. One full handwheel rotation moves the quill 1/10" for up to a maximum of 4" of travel. The quill also has a metric scale from 1mm–100mm.

# Offsetting Tailstock

By offsetting the tailstock, the dead center can hold a workpiece at a particular away from the spindle centerline so tapers and pipe threads can be cut. For a quick visual tool in keeping track of tailstock movement, an offset scale (see **Figure 36**) with arbitrary increments is located at the rear of the tailstock. However, to achieve exact taper angles, or to adjust the tailstock back into the spindle centerline, angle gauges and a test indicator must be used.

## To offset the tailstock:

1. Loosen the tailstock lock lever.
2. Using a 4mm hex wrench, loosen one of the front or rear adjustment screws shown in **Figure 36**.



**Figure 36.** Tailstock off-set adjustments.

—To move the tailstock toward the rear of the lathe, loosen the front adjustment screw and tighten the rear screw.

—To move the tailstock toward the front of the lathe, loosen the rear adjustment screw and tighten the front screw.

3. Apply the tailstock lock lever, and check the amount of the tailstock offset. Unlock and readjust as required for fine tuning.



# Aligning Tailstock

The tailstock alignment was set at the factory with the headstock. However, we recommend that you take the time to ensure that the tailstock is aligned to your own desired tolerances.

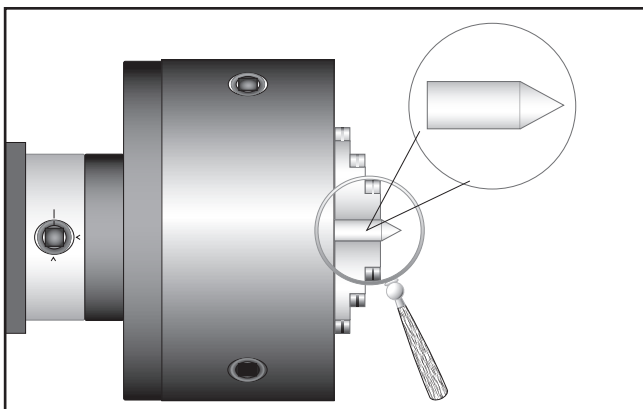
When clamped in place, a tailstock experiences compression that draws its centerline downward into alignment with the spindle centerline. This distance is usually a few thousandths of an inch. When a tailstock lock lever is used by feel, or when used by different machinists, this alignment can be inconsistent.

To eliminate this variable, a  $\frac{1}{2}$ " drive ft/lb torque wrench can be inserted into the lock lever drive hub. The tailstock can then be clamped in place at a pre-determined torque setting. All operators can then rely on the same amount of draw-down alignment that is based on the same torque setting.

## To align the tailstock:

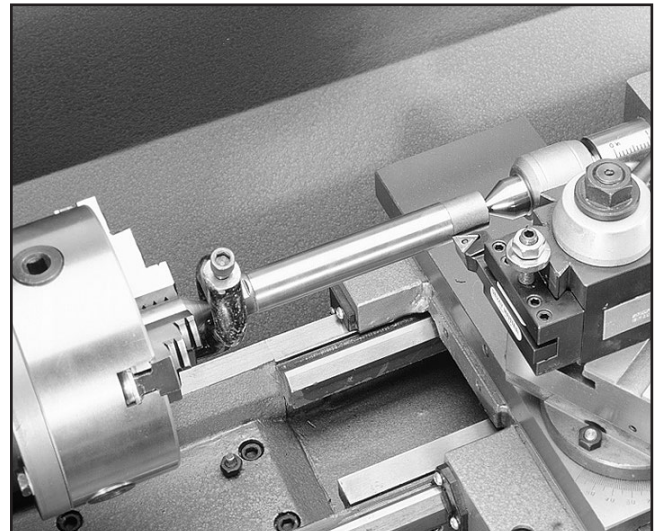
1. Center drill a 6" long piece of bar stock on both ends. Set it aside for use in **Step 4**.
2. Make a dead center by turning a shoulder to make a shank. Flip the piece over in the chuck and turn a  $60^\circ$  point (see **Figure 37**). As long as it remains in the chuck, the point of your center will be accurate to the spindle axis.

**Note:** *Keep in mind that the point will have to be refinished whenever it is removed and returned to the chuck.*



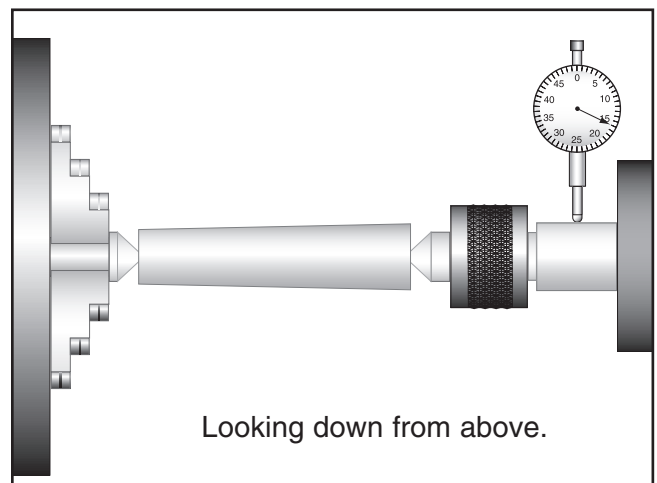
**Figure 37.** Finished dead center.

3. Place the live center in your tailstock.
4. Attach a lathe dog at the spindle end to the bar stock from **Step 1**, and mount it between the centers as shown in **Figure 38**.



**Figure 38.** Bar stock mounted between centers.

5. Turn approximately 0.010" off the diameter.
6. Mount a dial indicator so that the plunger is on the tailstock quill (see **Figure 39**).

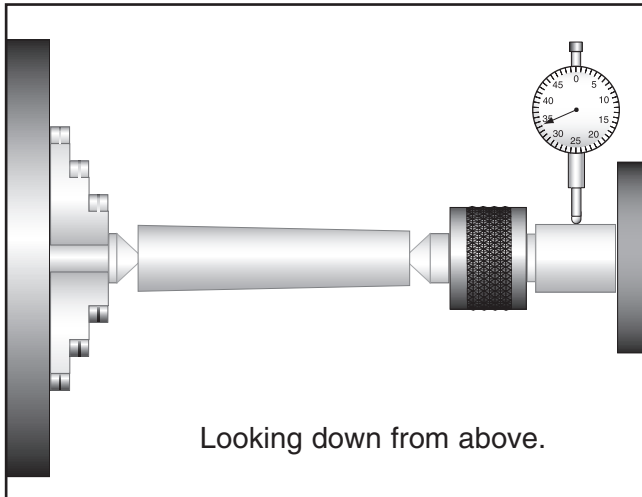


**Figure 39.** Adjusting for headstock end taper.

7. Measure the stock with a micrometer. If the stock is wider at the tailstock end, the tailstock needs to be moved toward the front of the lathe the amount of the taper (see **Figure 39**).



- If the stock is thinner at the tailstock end, the tailstock needs to be moved toward the rear of the lathe by at least the amount of the taper (see **Figure 40**).



**Figure 40.** Adjusting for tailstock end taper.

## ***NOTICE***

**DO NOT forget to lock the tailstock to the ways after each adjustment.**

8. Loosen the tailstock lock lever and adjust the tailstock offset by the amount of the taper.
9. Turn another 0.010" off of the stock and check for any taper.
10. Repeat as necessary until the desired level of accuracy is achieved.

# Drilling with Tailstock

The tailstock quill has an MT#3 taper with a lock slot at the bottom to accept tang-style tooling. If the tooling will experience high torque loads during operation, it is critical to use tanged-style to prevent the drill bit or arbor from spinning and galling the quill bore. Restoring a galled bore and taper can be time consuming or require quill replacement.

However, tooling without tang-styled arbors can be used if they meet the following criteria.

- Very little torque loads will be applied to the tooling such as with centers.
- The tap or drill bit is not larger than 1/2" in diameter.
- The end of the arbor is solid, or has a screw threaded into the hole making the end of the arbor solid. Installing an arbor with a solid end is important to avoid the arbor from becoming stuck in the quill. Some arbors equipped with the hole are too short to be exposed in the drift slot for removal, and the tailstock pin has no surface to push against when using the handwheel to remove the arbor. As a result, the arbor becomes stuck requiring the quill to be removed and the arbor driven out with a punch.



**Tip:** When drilling or when tapping operations need to be done deep into a part, the quill can also be stabilized by slightly applying the lever to add drag and preload to the quill.

**To install a tapered drill or chuck:**

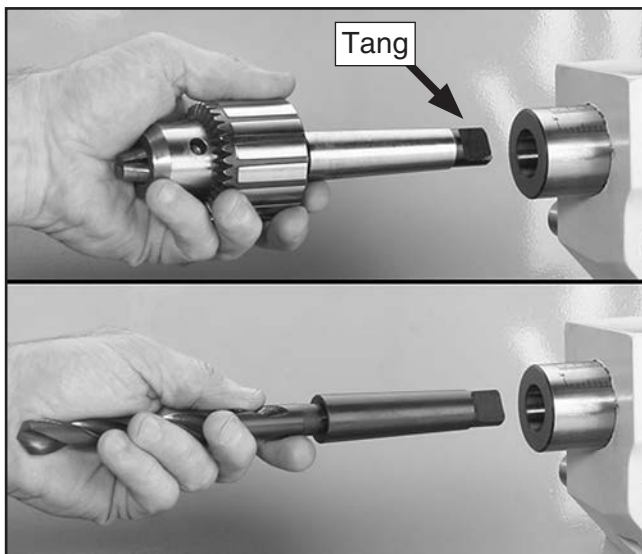
1. Lock the tailstock in position, then unlock the quill.
2. Use the quill feed handwheel to extend the quill about 1" out of the tailstock.
3. Insert an MT#3 chuck arbor or drill bit into the quill just until the tang drops into the slot and the tapers just touch.

**Tip:** For maximum locking of large diameter drill bits, push and seat the drill bit into the quill with a clockwise rotation as to load the tang against its slot.

4. Tap the end of the tooling or drill bit with a wooden block or mallet to seat the tool.
5. Lock the quill.

**To remove a tapered drill or chuck:**

1. Turn the handwheel counterclockwise until the arbor or drill bit is pushed out from the tailstock taper.  
—If the tool is stuck in the bore and cannot be removed by turning the handwheel with moderate force, extend the quill to expose the drift key slot, and use any standard drift key to remove the stuck tooling.

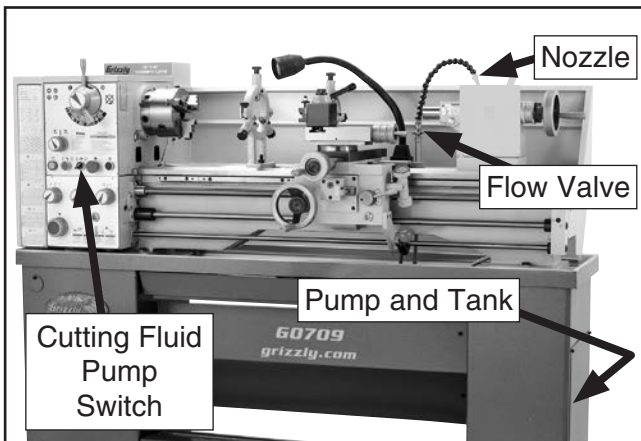


**Figure 41.** Typical drill chuck and arbor-style drill bit installation.



# Cutting Fluid System

The cutting fluid system delivers cutting fluid via a flexible distribution hose and nozzle. The cutting fluid pump turns ON and OFF with a switch located on the control panel. Fluid flow is controlled by a manual flow control valve near the base of the distribution hose (see **Figure 42**).



**Figure 42.** Cutting fluid system controls.

## **NOTICE**

**Running the pump without adequate cutting fluid in the reservoir may permanently damage it. This type of damage is not covered by the warranty.**

Always use high quality cutting fluid and follow the manufacturer's instructions for diluting. Frequently check the cutting fluid condition and change it promptly when it becomes overly dirty or rancid. Refer to **Cutting Fluid** on **Page 56** for changing the fluid or filling for the first time.

### **To use the cutting fluid system:**

1. Make sure the cutting fluid tank is properly serviced and filled.
2. Position the cutting fluid nozzle as desired for your operation.
3. Use the control panel switch to turn the cutting fluid pump **ON**.
4. Adjust the flow of cutting fluid by using the valve lever at the base of the nozzle hose.

# Steady Rest & Follow Rest

## **Selecting and Using Rests**

To minimize deflection, in workpieces like rods, dowels, tubes, and small diameter solid shafts, the steady rest or follow rest is used.

The steady rest is clamped to the ways and supports the workpiece with three fingers at a single point between the chuck and the tailstock.

The follow rest is bolted to the carriage and travels with it during turning or threading operations. Two fingers support the workpiece while the tool tip acts as the third support during cutting.

Both the steady rest and the follow rest use ball bearing-tipped fingers instead of solid brass tips. The fingers have a guide slot where the tip of an adjustable set screw rides. These screws are held in place with jam nuts. The set screws must be tightened inward far enough so they bottom slightly, providing preload and keeping the finger in alignment with only slight rocking in its bore.

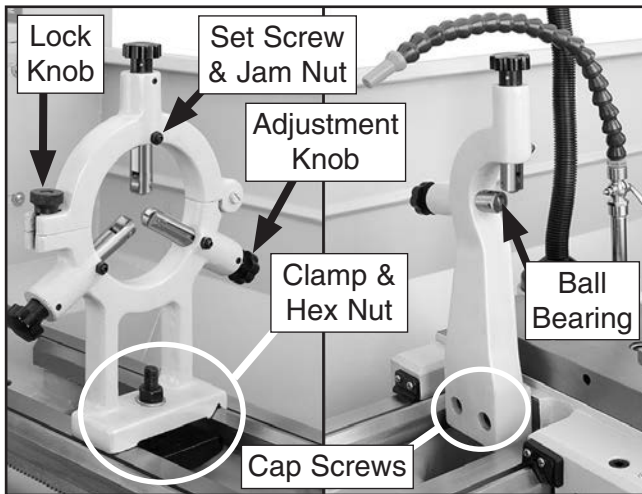
When using either of these rests, keep in mind that most machining operations must be done at low spindle speeds to prevent a workpiece ejection hazard.





## To install the rests:

1. DISCONNECT LATHE FROM POWER!
2. Select the required rest (see **Figure 43**) for the operation, and wipe all mounting surfaces clean with a lightly oiled rag.



**Figure 43.** Steady rest and follow rest.

—To install the steady rest, place it on the lathe bed where workpiece support is needed. Engage the base clamp with the way underside and tighten the mounting nut with a 27mm wrench.

—To install the follow rest, fasten the base to the saddle with two provided M8-1.25 x 30 cap screws using a 6mm hex wrench.

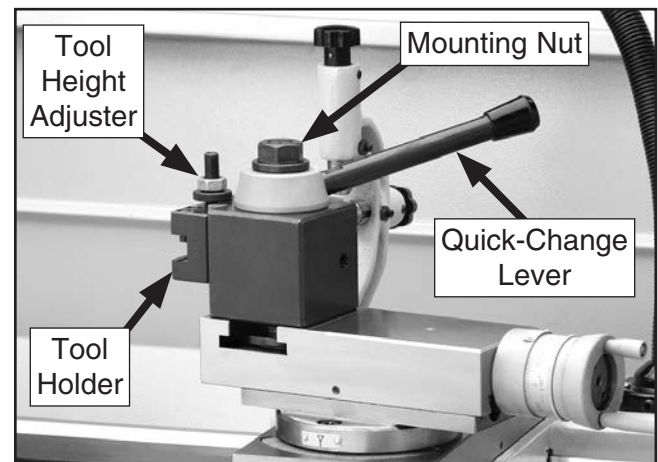
3. Install the workpiece and support it at both ends.
4. Without causing deflection, adjust the fingers until the bearings just touch the workpiece.
5. Lock the fingers in place with the set screws and jam nuts.

# Tool Post

The included tool post is a 200 series piston-type quick-change model. The quick-change lock lever allows for one or more tool holders to be quickly loaded and unloaded in two available dovetailed slots. By having extra tool holders and setting the tool height in advance, swapping between tooling is efficient for production-sensitive schedules. When loosened, the mounting hex nut shown in **Figure 39** allows the entire tool post to rotate 360° for angle adjustments.

## To load a tool holder:

1. Install the required cutting tool in the tool holder.
2. Move the quick-change lever (see **Figure 44**) to recess the lock piston and provide an unobstructed slot for the tool holder to slide down into.



**Figure 44.** Tool post bolts.

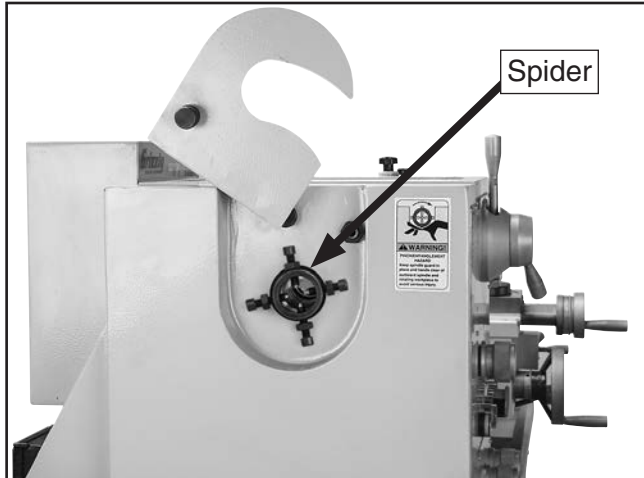
3. Slide the tool holder into position, and tighten the quick-change lever.
4. Use the handwheels to bring the tool to the required position.
5. Double check that tool angle, height, and position are correct.
6. Make sure that all fasteners related to the tool, holder, and tool post are tight.





# Spider

Your lathe is equipped with a set of outboard spindle supports known as a "spider," shown in **Figure 45**.



**Figure 45.** Spider assembly located on the outboard spindle.

Use the spider when a long workpiece has the potential to wobble or vibrate when it extends through the outboard side of the spindle.

The tips of the spider screws have brass wear pads that hold the workpiece without causing indents or marring.

When the spider screws are installed, and regardless if they are used to hold a workpiece or not, always lock each spider screw in place by tightening the jam nuts. If a workpiece is installed, merely tightening the spider screws against the workpiece and leaving the jam nuts loose is not safe. Spider screws that loosen during operation can crash into the lathe end cover.

## CAUTION

**To avoid creating an entanglement hazard, remove the spider screws when not in use, and always disconnect the lathe from power when installing, removing, or adjusting the spider screws. Ignoring this warning can lead to personal injury or machine damage.**

# Spindle Speed

Using the correct spindle speed is important for safe and satisfactory results, as well as maximizing tool life.

To set the spindle speed for your operation, you will need to: (1) Determine the best spindle speed for the cutting task, and (2) configure the lathe controls to produce the required spindle speed.

## Determining Spindle Speed

Many variables affect the optimum spindle speed to use for any given operations, but the two most important are the recommended cutting speed for the workpiece material and the diameter of the workpiece, as noted in the formula shown in **Figure 46**.

$$\frac{\text{*Recommended Cutting Speed (FPM)} \times 12}{\text{Dia. of Cut (in inches)} \times 3.14} = \text{Spindle Speed (RPM)}$$

\*Double if using carbide cutting tool

**Figure 46.** Spindle speed formula for lathes.

Cutting speed, typically defined in feet per minute (FPM), is the speed at which the edge of a tool moves across the material surface.

A recommended cutting speed is an ideal speed for cutting a type of material in order to produce the desired finish and optimize tool life.

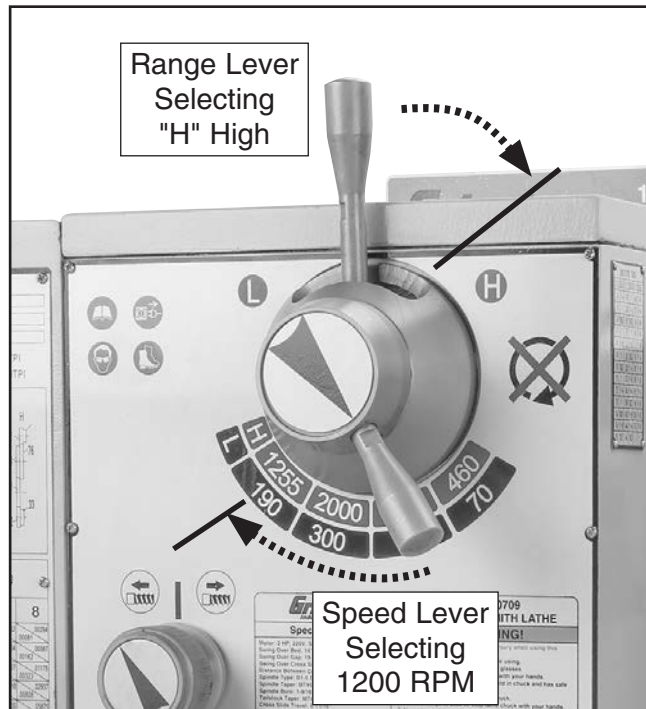
The books *Machinery's Handbook* or *Machine Shop Practice*, and some internet sites, provide excellent recommendations for which cutting speeds to use when calculating the spindle speed. These sources also provide a wealth of additional information about the variables that affect cutting speed and they are a good educational resource.

Also, there are a large number of easy-to-use spindle speed calculators that can be found on the internet. All of these sources will help you take into account all the applicable variables in order to determine the best spindle speed for the operation.



## Changing Spindle Speed

This lathe is equipped with two levers shown in **Figure 47** that are used to achieve eight spindle speeds. **Never move either lever while the spindle is rotating, or gear clash and tooth fracture may occur.** When the lathe is stopped, if the levers do not fully engage, the spindle must be slightly rotated by hand.



**Figure 47.** Spindle speed levers.

If the spindle speed range lever (see **Figure 47**) is positioned in low "L", the four spindle speeds listed in the black indicator are available. If the range lever is positioned in high "H", the four spindle speeds listed in the red indicator are available.

The spindle speed lever shown in **Figure 47** has eight speed selections depending on if the spindle speed range lever is in high or low.

When in low range, the available spindle speeds are 70, 115, 190, and 300, and when in high range, the available speeds are 460, 755, 1255, and 2000.

### To change the spindle speed:

1. Determine the spindle speed required for the lathe operation.
2. Move the spindle speed range lever to the right for high range or left for low range.
3. Move the spindle speed lever to the left so it is over the required speed, for example 1200 RPM is being selected in **Figure 47**.

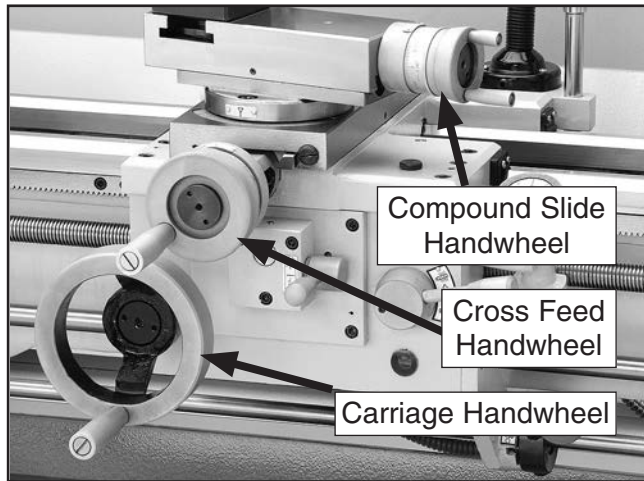
—When the range lever is in high, the speeds in the red band are available.

—When the range lever is in low, the speeds in the black band are available.



# Manual Feed

You can manually move the cutting tool around the lathe for facing or turning operations using the handwheels shown in **Figure 48** and described below.



**Figure 48.** Manual feed controls.

## Carriage Handwheel

For moves the carriage longitudinally left or right along the ways in increments of 0.006" for a total rotary distance of 0.564". One full rotation of this handwheel equates to approximately  $\frac{9}{16}$ " of carriage longitudinal travel, thus establishing a 1:1 ratio between the two.

## Cross Slide Handwheel

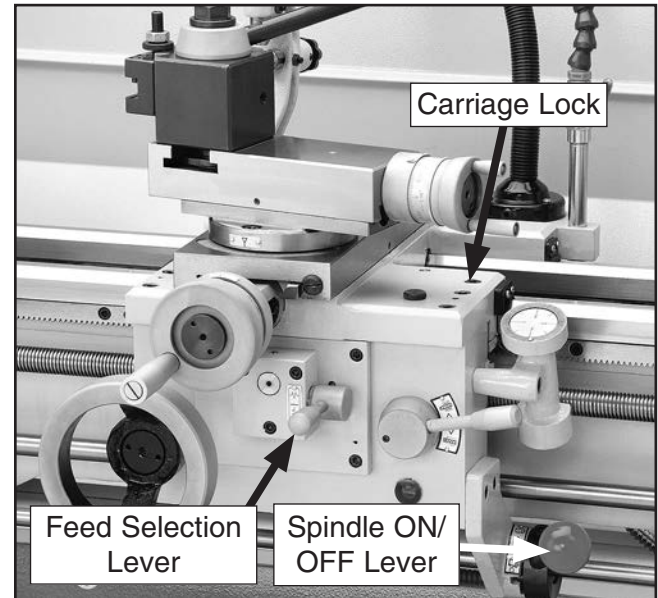
Moves the cross slide in or out perpendicular to carriage travel with a 10-TPI leadscrew. Movement is in increments of 0.001", where a total revolution of 0.100" equals 0.200" of cross slide movement. This micrometer scale is a "Standard Dial" that has a ratio of 1:2. For example, if the hand wheel is rotated clockwise 0.015" during a turning operation, 0.030" will be removed from the overall diameter of the workpiece, as the outside diameter is measured with a caliper.

## Compound Slide Handwheel

Moves the compound and cutting tool relative to the workpiece at various angles with fine-depth control in inch calibrations. One full rotation equals 0.100" of compound movement or equates to a ratio of 1:1. The scale is broken down in increments of 0.001".

# Power Feed

The feed selection lever (see **Figure 49**) allows the machinist to engage or disengage the apron for longitudinal or cross feeding tasks.



**Figure 49.** Power feed controls.

Sometimes it is necessary to rock the carriage handwheel or the cross feed handwheel to assist in fully engaging the chosen feed gears. To prevent inadvertent apron damage, the apron is equipped with an internal lockout system that prevents the feed selection lever and half-nut levers from being engaged at the same time. However, before engaging the apron for any longitudinal feed operations, make sure that the carriage lock is loose and the carriage is allowed to move freely, or the feed system may be damaged.

Moving the feed selection lever upwards from the central or disengaged position engages the cross slide for in-and-out facing operations.

Moving the feed selection lever downwards from the central disengaged position, engages the carriage for left-or-right longitudinal turning operations.

The speed at which the carriage travels is set with the feed speed dials (refer to **Feed Settings** on **Page 44**). The feed direction is changed by the feed direction lever on the headstock.



## NOTICE

A high feed rate or threading at a high speed reduces your reaction time to disengage the apron or leadscrew to avoid a crash with the spinning chuck. When threading, making too deep of a cut can result in the half nut binding with the leadscrew causing an impaired ability to disengage the half nut to avoid a chuck crash. Pay close attention to the feed rate you have chosen and keep your foot poised over the brake pedal. Failure to fully understand this may cause the carriage to crash into the chuck.

## Feed Settings

Various feed rates are achieved on this lathe by moving knobs, levers, and rearranging change gears according to the threading chart located on the headstock. *All required change gears are pre-installed on this lathe, and no external gears are required.*

### To set up for a power feed operation:

1. DISCONNECT LATHE FROM POWER!
2. Remove the cover on the left-hand side of the headstock to expose the change gears.
3. Look at the lathe feed rate chart, and find the required feed rate for your turning or facing operation. In each box on the chart, two numbers are separated by a slash (see **Figure 50**). The top-right number is carriage feed, and the bottom-left number is cross feed. If for example, a carriage feed rate of 0.00168" is needed, the change gears and feed dials must be in the following positions **FATX1**.

—"F" is the first letter in the sequence and indicates that the change gears must be rearranged in the "F" sequence as shown in **Figure 51**. The change gears are located on the left-hand side of the lathe, behind the headstock gear cover shown in.

—"ATX" is the second group of letters that indicate which positions to turn the lettered-feed dials to.

—"1" is the last digit and indicates which position to turn the numbered feed dial to.

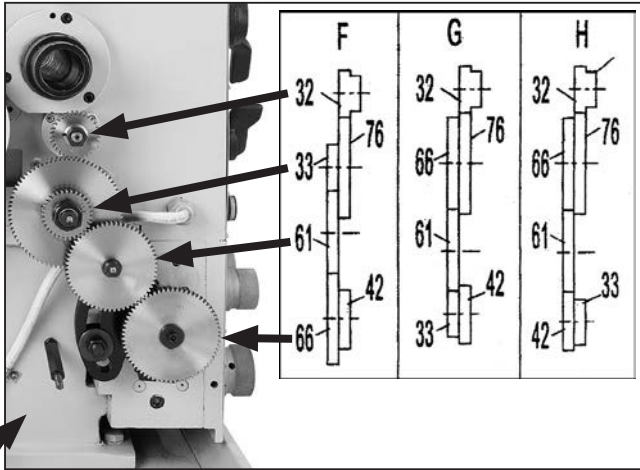
	1	3	6	8
Carriage Feed Rate	.00168	.00210	.00252	.00294
Cross Slide Feed Rate	.00046	.00057	.00069	.00081
	.00336	.00420	.00504	.00587

Figure 50. Feed rate chart.



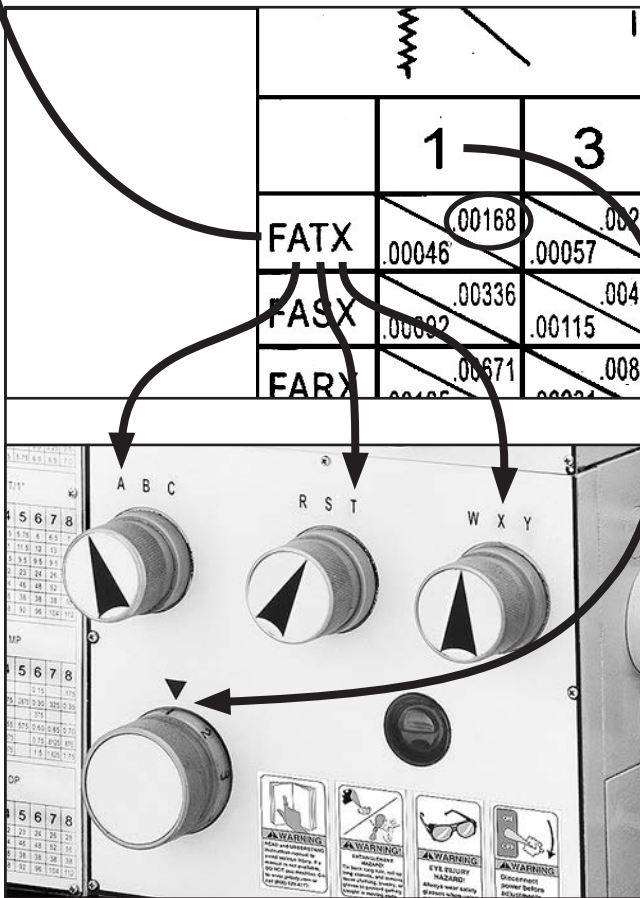


- Leaving 0.003"–0.005" backlash between gear teeth, arrange the change gears to match the order under "F" (see **Figure 51**).



**Figure 51.** Change gear and chart relationship.

- Rotate the spindle by hand to verify no binding exists, and re-install the gear cover.
- Move the feed dials to the combination of **FATX1**, as shown in **Figure 52**.



**Figure 52.** Feed control settings for a 0.00168" carriage feed rate.

# Thread Settings

Regardless of the example given below, the setup procedure on this lathe is the same for metric, inch, module, or diametral pitch threads. These thread selections are indicated by a series of letters and numbers shown on the headstock threading charts. First, the change gear positions are checked and rearranged if indicated by the chart. Next, the quick change gearbox knobs and levers are moved to specific positions also indicated by the chart.

## To set up for threading:

- DISCONNECT LATHE FROM POWER!
- Remove the cover on the left-hand side of the headstock to expose the change gears.
- Review the threading chart for the required thread to be cut (see **Figure 53**). The chart indicates that to cut a 0.75 metric thread, the change gears and feed dials must be in the following positions **FBSW6**.

—"F" is the first letter in the sequence and indicates that the change gears must be rearranged in the "F" order (see **Figure 54**).

—"BSW" is the second group of letters that indicate which position to turn the lettered-feed dials to.

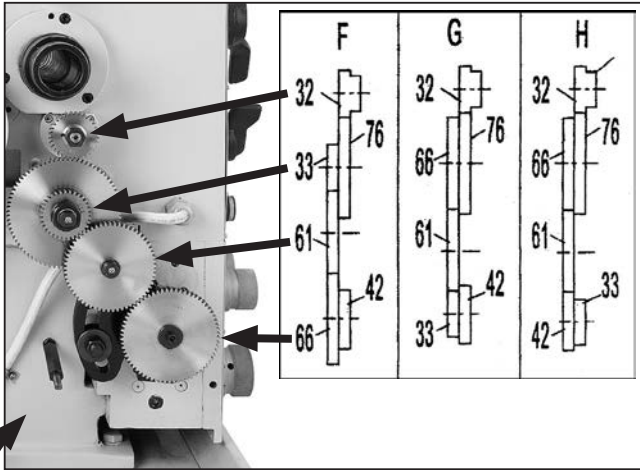
—"6" is the last digit and indicates which position to turn the numbered feed dial to.

	1	2	3	4	5	6	7	8
FATW	0.10		.125			0.15		
FASW	0.20	.225	0.25			0.30		0.35
FARW	0.40	0.45	0.50	0.55		0.60	0.65	0.70
<b>FBSW</b>						<b>0.75</b>		.875
GASW	0.80	0.90		1.1		1.2	1.3	1.4
FBRW	1.0		1.25			1.5		1.75

**Figure 53.** Metric thread pitch chart.

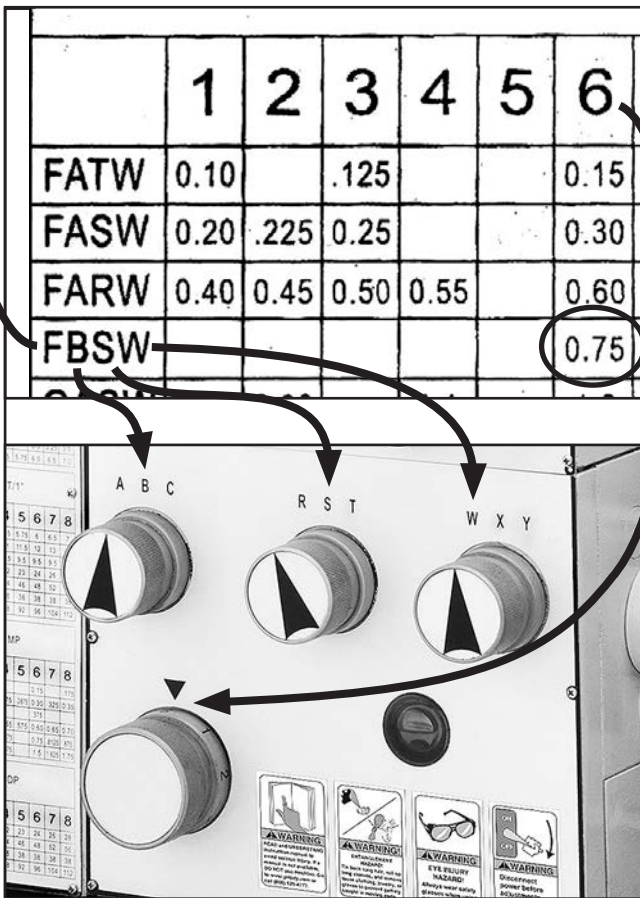


- Leaving 0.003"–0.005" backlash between gear teeth, arrange the change gears to match the order under "F" (see **Figure 54**).



**Figure 54.** Change gear and chart relationship.

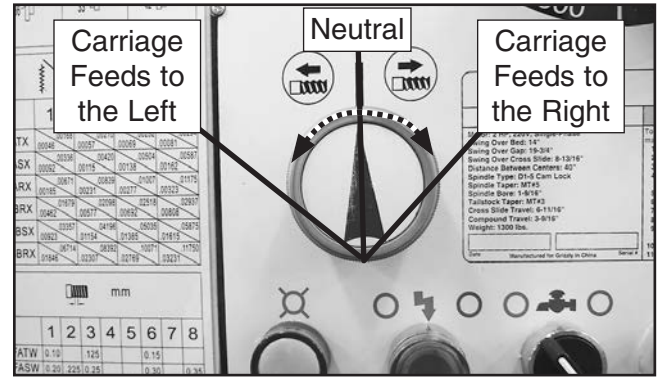
- Rotate the spindle by hand to verify no binding exists, and re-install the gear cover.
- Move the threading dials to the combination of **FBSW6**, as shown in **Figure 55**.



**Figure 55.** Thread control settings for 0.75 pitch.

## Feed Direction Lever

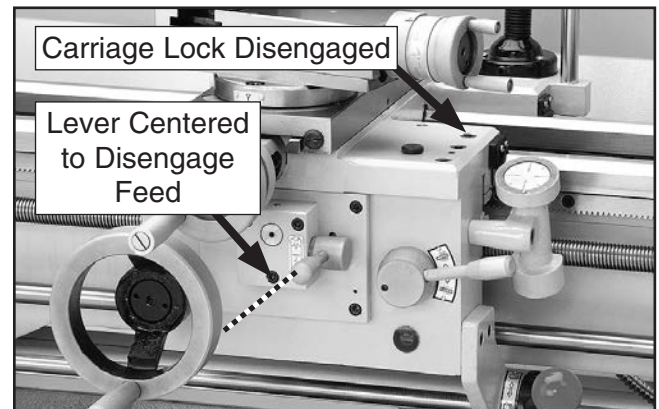
When threading, the feed direction lever (see **Figure 56**) moves the carriage to the left toward the headstock (forward), and moves the carriage to the right toward the tailstock (reverse). The leadscrew will not turn when the feed direction lever is in the neutral position.



**Figure 56.** Feed direction controls for threading.

## Feed Selection Lever

To prevent apron and drive system damage, the apron is equipped with an internal lockout, meaning that in order to engage the half nut for threading, this lever (see **Figure 57**) must be moved to the central or the disengaged position. Also keep in mind that just as with longitudinal feed operations, before any threading operation. You must first verify the carriage lock (see **Figure 57**) is disengaged, or the feed system may be damaged.



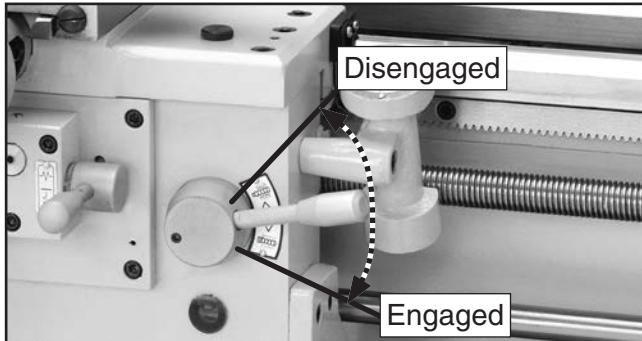
**Figure 57.** Feed selection lever disengaged.





## Half-Nut Lever

When the feed selection lever and carriage lock are disengaged, the half-nut lever (**Figure 58**) can be moved downward from the disengaged upper position to clamp the half nut around the leadscrew for threading operations.



**Figure 58.** Half nut lever.

### **CAUTION**

**DO NOT engage the half nut if the leadscrew will rotate over 200 RPM, or if the carriage lock is applied. Disregarding this warning may cause damage to the bearings or the leadscrew shear pin to break.**

## Thread Dial

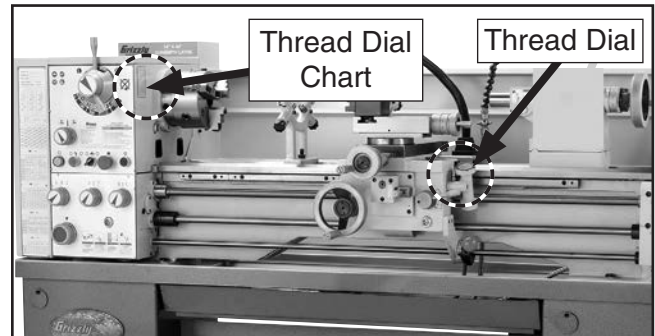
When cutting inch threads and the pass has been completed, the thread dial (see **Figure 59**) allows the machinist to disengage the carriage from the leadscrew, and quickly return the carriage for the next pass. Based on the thread TPI being cut, and what is indicated on the thread chart, the dial indicates where the machinist must re-clamp the half nut in order to resume the same thread to avoid cross-cutting threads.

When cutting metric and other types of threads, the thread dial must be disengaged from the leadscrew, and the half nut clamped to the leadscrew until the threads are complete. Otherwise the path of the same thread will be lost. All carriage returns for non-inch threads are made by backing the tool point out of the thread, and reversing spindle rotation with the spindle ON/OFF lever.

To engage the thread dial, loosen the mounting cap screw, then pivot the dial into the leadscrew so the gear teeth mesh with the leadscrew. Retighten the cap screw to hold the thread dial in place.

## Thread Dial Chart

The thread dial chart is located on the headstock cover, as shown in **Figure 59**.



**Figure 59.** Thread dial chart and thread dial locations.

To use the thread dial chart, find the TPI that you want to cut and reference the "Scale" number(s) next to it. The scale number(s) indicate when to engage the half nut when cutting that TPI.

**For Example:** If you are cutting 13 TPI threads, the chart shows "1, 3, 5, 7" next to the 13 (see the shaded boxes in **Figure 60**).

INDICATOR TABLE					
T.P.I.	SCALE	T.P.I.	SCALE	T.P.I.	SCALE
3-1/2	1,5/3,7	11-1/2	1,5/3,7	38	1-8
4	1-8	12	1-8	40	1-8
4-1/2	1,5/3,7	13	1,3,5,7	42	1-8
5	1,3,5,7	14	1-8	44	1-8
5-1/4	1	16	1-8	46	1-8
5-1/2	1,5/3,7	18	1-8	48	1-8
5-3/4	1	19	1,3,5,7	52	1-8
6	1-8	20	1-8	56	1-8
6-1/2	1,5/3,7	21	1,3,5,7	64	1-8
7	1,3,5,7	22	1-8	72	1-8
8	1-8	23	1,3,5,7	80	1-8
9	1,3,5,7	24	1-8	88	1-8
9-1/2	1,5/3,7	26	1-8	92	1-8
10	1-8	28	1-8	96	1-8
10-1/2	1,5/3,7	32	1-8	104	1-8
11	1,3,5,7	36	1-8	112	1-8

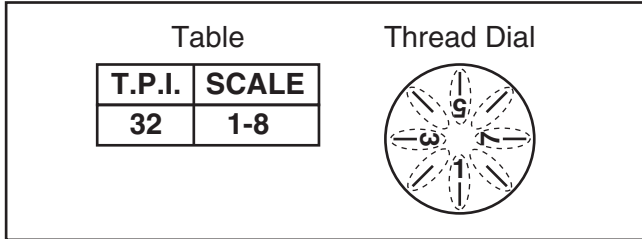
**Figure 60.** Thread dial chart.

**IMPORTANT:** You can engage on the number 1 on the thread dial to cut any thread if you do not want to use the chart, or if you forget any of the rules on the next page.



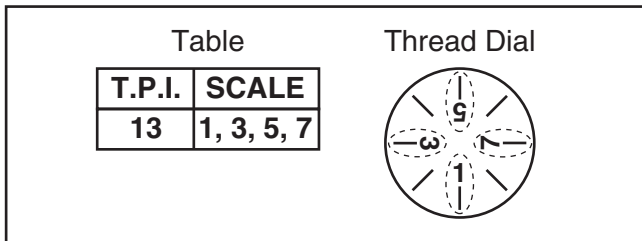
The following examples explain how to use the thread dial and the thread dial chart.

**Even TPI:** For threading even numbered TPI, use any mark on the thread dial (see the example in **Figure 61**).



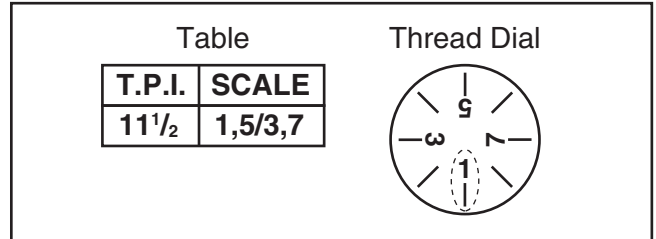
**Figure 61.** Any mark on dial for threading even numbered TPI.

**Odd TPI:** For threading odd numbered TPI, use any numbered line on the thread dial (see the example in **Figure 62**).



**Figure 62.** Any number on dial for threading odd numbered TPI.

**Any Other TPI:** For threading any other TPI, use only the number 1 on the thread dial (see the example in **Figure 63**).



**Figure 63.** Thread dial position for any numbered TPI.



# SECTION 5: ACCESSORIES

## **!WARNING**

Installing unapproved accessories may cause machine to malfunction, resulting in serious personal injury or machine damage. To reduce this risk, only install accessories recommended for this machine by Grizzly.

## **NOTICE**

Refer to our website or latest catalog for additional recommended accessories.

### **H6095—Digital Readout (DRO)**

This is one of the finest DRO's on the market today. Features selectable resolution down to 5 $\mu$ m, absolute/incremental coordinate display, arc function, radius/diameter function, master reference datum, 199 machinist defined tools, double sealed scales, inches/millimeters and linear error compensation. Don't be fooled by our low prices—this is only a reflection of the absence of any “middlemen” in the marketing structure—not a reflection of the quality.

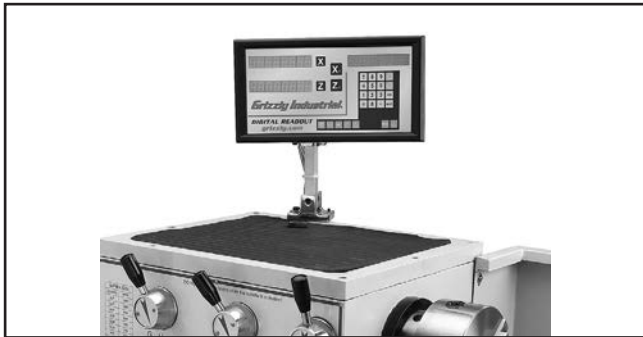


Figure 64. H6095 Digital Readout.

### **H9240—Water Soluble Machining Oil**

Rustlick water soluble machining oil contains effective chlorinated E.P. additive to provide excellent tool life. Guaranteed to protect neoprene seals. Great for general purpose or heavy duty applications. Can be used on all metals except titanium.



Figure 65. H9240 Rustlick Machining Oil.

### **H5786—MT#3 x 4" Bull Nose Rolling Center**

### **H5902—MT#3 x 2" Bull Nose Rolling Center**

Built with precision sealed bearings, designed for heavy-duty use on hollow workpieces.



Figure 66. MT#3 bull nose rolling centers.

**order online at [www.grizzly.com](http://www.grizzly.com) or call 1-800-523-4777**



**G9888—MT#3 Long Nose Precision Center**  
 Provides critical tool clearance. Adjustable thrust bearings, 60° tip and 30° clearance relief angle.

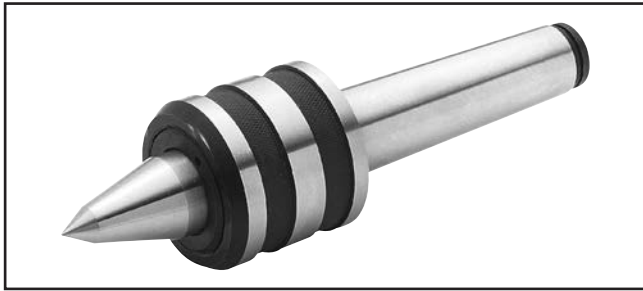


Figure 67. MT#3 Long Nose Center

**Quick Change Tool Holders**

All models are Series 200

- G5701—Boring Bar Holder 3/4"
- G5704—Parting Tool Holder 5/8"
- G5705—Knurling Tool Holder 1/4"~5/8"
- G5703—Morse Taper Holder MT#3
- G5700—Turning/Boring Holder 1/4"~5/8"; 1/2"Ø
- G5699—Turning Holders 1/4"~5/8"

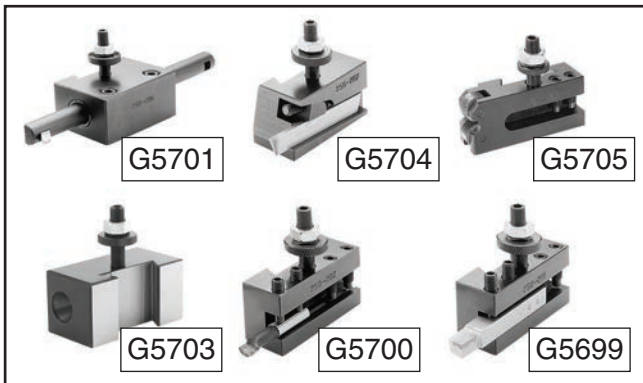


Figure 68. Quick change tool holders.

**G1070—MT3 Live Center Set**  
 A super blend of quality and convenience, this live center set offers seven interchangeable tips. High-quality needle bearings prolong tool life and special tool steel body and tips are precision ground. Supplied in wooden box.



Figure 69. G1070 Live Center Set.

**Basic Eye Protection**

- T20501—Face Shield Crown Protector 4"
- T20502—Face Shield Crown Protector 7"
- T20503—Face Shield Window
- T20451—"Kirova" Clear Safety Glasses
- T20452—"Kirova" Anti-Reflective S. Glasses
- T20456—DAKURA Safety Glasses, Black/Clear



Figure 70. Assortment of basic eye protection.

**order online at [www.grizzly.com](http://www.grizzly.com) or call 1-800-523-4777**



MODEL	SIZE	BODY DIA.	DRILL DIA.	OVERALL LENGTH
H4456	1	1/8"	3/64"	1 1/4"
H4457	2	3/16"	5/64"	1 7/8"
H4458	3	1/4"	7/64"	2"
H4459	4	5/16"	1/8"	2 1/8"
H4460	5	7/16"	3/16"	2 3/4"
H4461	6	1/2"	7/32"	3"
H4462	7	5/8"	1/4"	3 1/4"
H4463	8	3/4"	5/16"	3 1/2"

These high speed steel center drills are precision ground for unsurpassed accuracy.

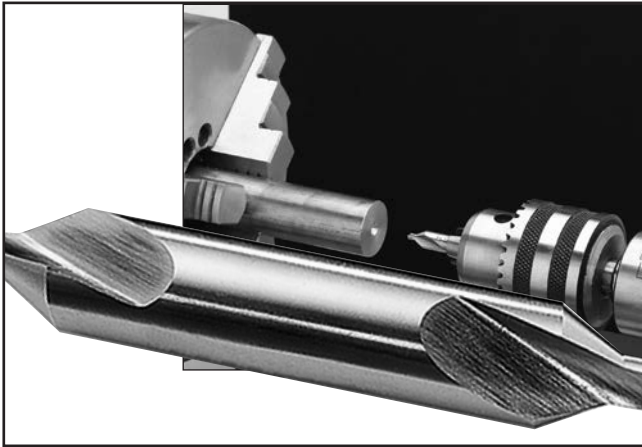


Figure 71. H4456-63 HSS Ground Center Drills.

**SB1365—South Bend Lathe Way Oil, 12 oz.**

**T23962—ISO 68 Moly-D Way Oil, 5 gal.**

**T23963—ISO 32 Moly-D Machine Oil, 5 gal.**

Moly-D oils are some of the best we've found for maintaining the critical components of machinery because they tend to resist run-off and maintain their lubricity under a variety of conditions—as well as reduce chatter or slip. Buy in bulk and save with 5-gallon quantities.



Figure 72. 12 oz. way oil & 5 gallon machine oil.

**H2987—1/2" Bent Lathe Dog**  
**H2988—1" Bent Lathe Dog**  
**H2989—1 1/2" Bent Lathe Dog**  
**H2990—2" Bent Lathe Dog**  
**H2991—3" Bent Lathe Dog**

Just the thing for precision machining between centers! These bent tail lathe dogs are made of durable cast iron and feature square head bolts.



Figure 73. H2987-91 Lathe Dogs.

**H7617—Oil Can w/Plastic Nozzle**

This high-pressure oil can is perfect for lubricating the ball oilers found on your machine. Each can holds 5 ounces of oil.



Figure 74. High-pressure oil can for ball oilers.

**order online at [www.grizzly.com](http://www.grizzly.com) or call 1-800-523-4777**





# SECTION 6: MAINTENANCE



## Schedule

For optimum performance from your machine, follow this maintenance schedule and refer to any specific instructions given in this section.

### Every 6–8 Hours of Running Time:

- Clean/vacuum lathe.
- Wipe down unpainted cast iron, including leadscrew, with way oil or other quality metal protectant.
- Lubricate ball oilers (**Page** ).
- Check oil reservoirs (**Page 54**).

### Each Week:

- Check cutting fluid system (**Page 56**). Clean tank and replace cutting fluid as necessary.

### Each Month:

- Check/adjust V-belt tension (**Page 68**).

### Every Six Months:

- Change oil in headstock, gearbox, and apron (**Page 55**).

## Unpainted Cast Iron

Protect the unpainted cast iron surfaces on the lathe by wiping them clean after every use—this ensures moisture does not remain on bare metal surfaces.

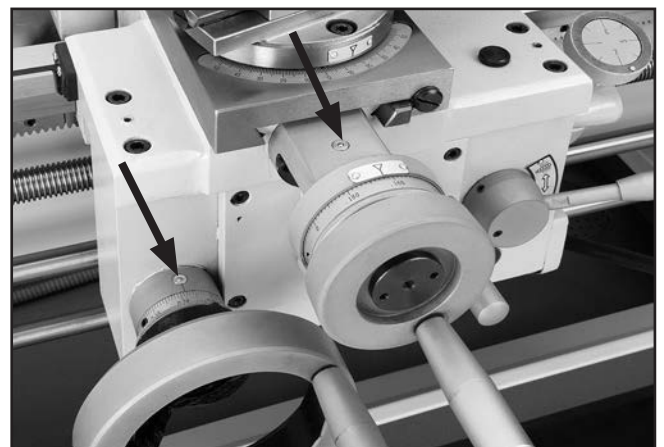
Keep ways rust-free with regular applications of SB1365 Way Oil.

## Cleaning

Cleaning the Model G0709 is relatively easy. Disconnect the lathe before cleaning it. Remove chips as they accumulate. Vacuum excess metal chips and wipe off the remaining cutting fluid with a dry cloth when finished for the day. Chips left on the machine soaked with water-based cutting fluid will invite oxidation and gummy residue to build up around moving parts. Preventative measures like these will help keep your lathe running smoothly. Always be safe and responsible with the use and disposal of cleaning products.

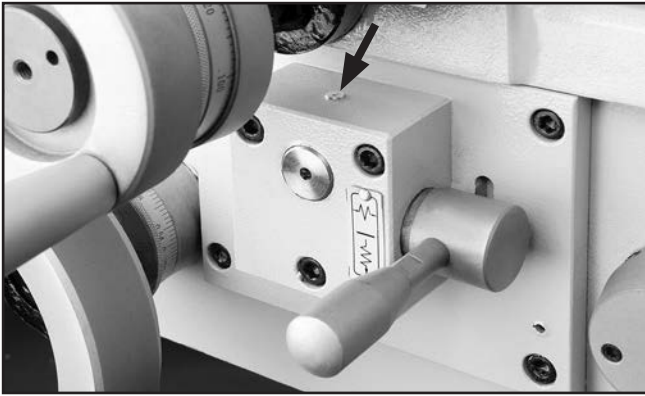
## Ball Oiler Lubrication

When lubricating ball oilers, we recommend using an oil gun with a rubber tip wide enough to seal against the ball oiler inlet. A good seal allows the gun to build enough hydraulic pressure to flush out contaminants and deliver oil at the end of long passages. We do not recommend using oil guns with a steel lance tip, because they do not create a seal and the narrow tip can easily dislodge the ball—resulting in contamination, insufficient lubrication, and a damaged ball oiler.

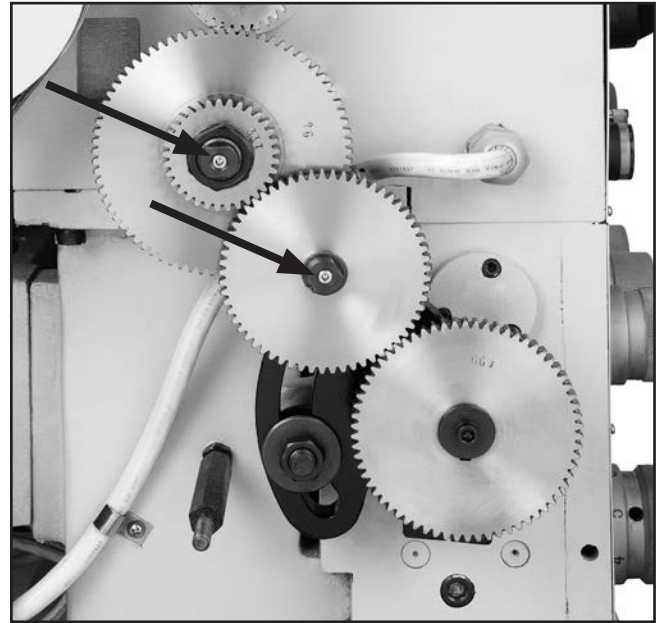


**Figure 75.** Handwheel ball oilers.





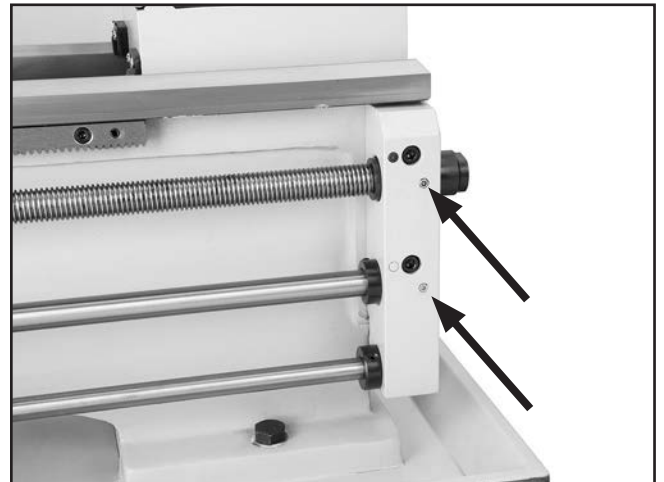
**Figure 76.** Feed selection lever ball oiler location.



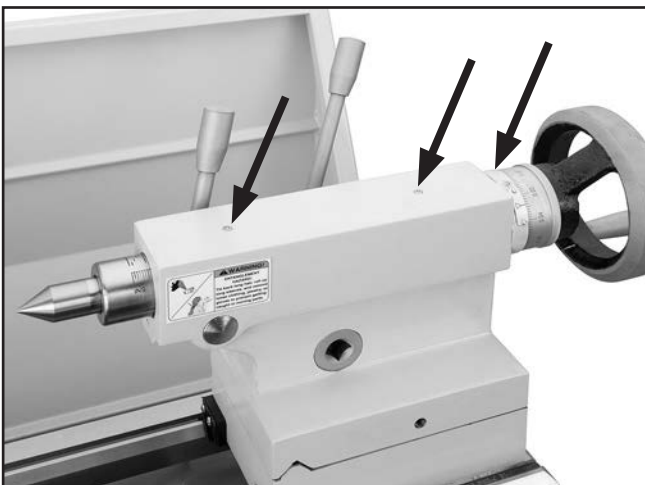
**Figure 79.** Change gear ball oilers.



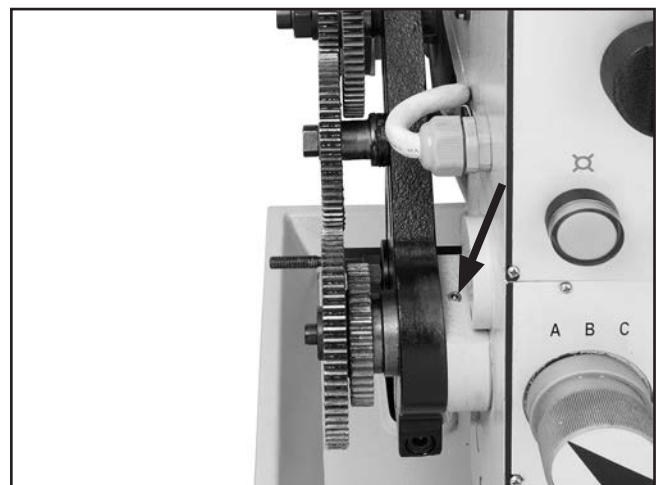
**Figure 77.** Saddle and slide ball oilers.



**Figure 80.** End cap ball oilers.



**Figure 78.** Tailstock ball oilers.



**Figure 81.** Change gear hub ball oiler.



# Oil Reservoirs

## Checking & Adding Oil

The headstock, gearbox, and apron have oil reservoirs that are equipped with sight glasses for quickly checking oil levels. Before and after every use, make sure that the oil levels are correct. **Figures 83–85** show the gearbox locations of the sight glasses and the fill/drain plugs.

## Recommended Oil Types

Headstock..... T23963 or ISO 32 equiv.  
QC Gearbox ..... T23962 or ISO 68 equiv.  
Apron..... T23962 or ISO 68 equiv.

**T23962—ISO 68 Moly-D Machine Oil, 5 gal.**

**T23963—ISO 32 Moly-D Machine Oil, 5 gal.**

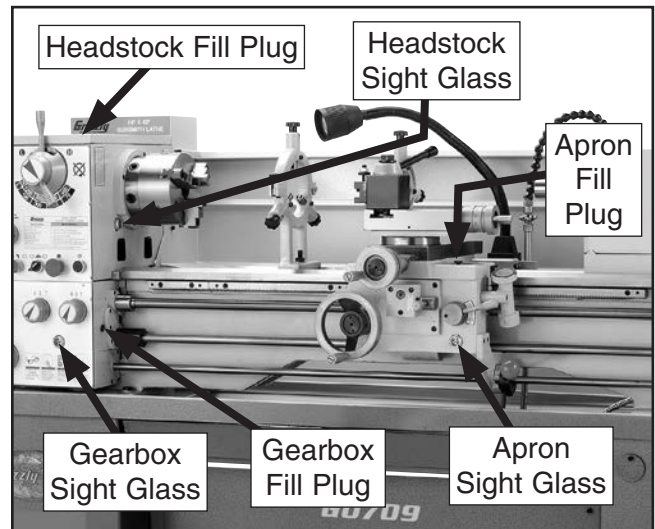
These Moly-D oils tend to resist run-off and maintain their lubricity under a variety of conditions—as well as reduce chatter or slip. Buy in bulk and save with 5-gallon quantities. Call 1-800-523-4777 or visit [www.grizzly.com](http://www.grizzly.com) to order.



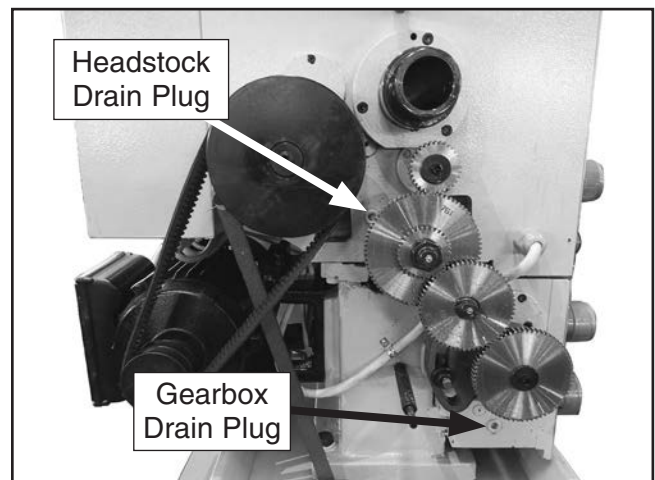
**Figure 82.** T23963 5-gallon ISO 32 machine oil.

### To add oil to the reservoirs:

1. Clean the area around the fill plug clean to prevent debris from falling in the reservoir when adding oil.
2. Remove the fill plug.
3. Slowly add oil until the oil level is centered in the sight glass.
4. Replace fill plug.



**Figure 83.** Location of oil sight glasses and exterior fill plugs.



**Figure 84.** Gearbox fill and drain plugs.



**Figure 85.** Apron drain plug.





## Changing Oil

The oil in the reservoirs must be changed after the first three months of operation, then twice a year after that. If the lathe is under heavy use, more frequent oil changes will be required to keep the gearboxes clean and ensure long machine life. Some lathe owners believe that by using full synthetic oils in the gearboxes is a way to extend oil change intervals. We do not recommend this practice. While synthetic oils are superior this lathe does not use a filter to remove contaminants that are generated during normal use, such as when shifting gears. Changing the oils on a frequent basis to flush out moisture and contaminants is still the best option to ensure long gearbox life.

Headstock Oil Capacity..... 4 Quarts  
 Headstock Oil Type ..... Grizzly #T23962  
 or ISO 32 equivalent

QC Gearbox Oil Capacity.....26 Ounces  
 QC Gearbox Oil Type ..... Grizzly #T23962  
 or ISO 68 equivalent

Apron Oil Capacity .....7 Ounces  
 Apron Oil Type..... Grizzly #T23962  
 or ISO 68 equivalent

<b>Tools Needed</b>	<b>Qty</b>
Drain Pan (at least 2 Gallon Capacity).....	1
Hex Wrench 5mm.....	1
Hex Wrench 6mm.....	1
Wrench 24mm .....	1

### To change the oil in the reservoirs:

1. Run the lathe to bring the lathe gearboxes to a warm temperature and turn **OFF** the lathe.
2. **DISCONNECT LATHE FROM POWER!**
3. Remove the headstock gear cover.
4. Using a funnel or cardboard ramp if desired to direct waste oil into the drain pan, position the drain pan under the gearbox drain plug.
5. Remove the fill plug and the drain plug from the selected oil reservoir, and allow all oil to drain.
6. Re-install the drain plug, add oil to the reservoir until the sight glass reads full. Then re-install the fill plug.

Model G0709 (Mfd. Since 01/21)



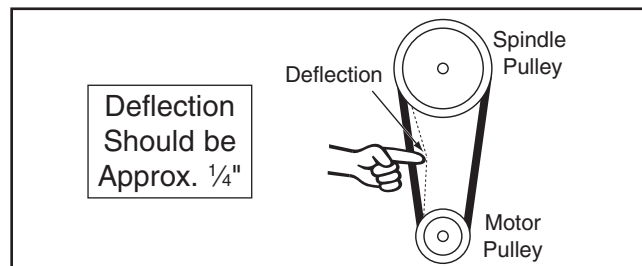
## V-Belt Tension

After initial break in, the V-belts slightly stretch and seat into the pulley. It is important to check and adjust them to compensate for this initial wear. Check the tension thereafter on a monthly basis.

<b>Tools Needed</b>	<b>Qty</b>
Hex Wrench 17mm.....	1

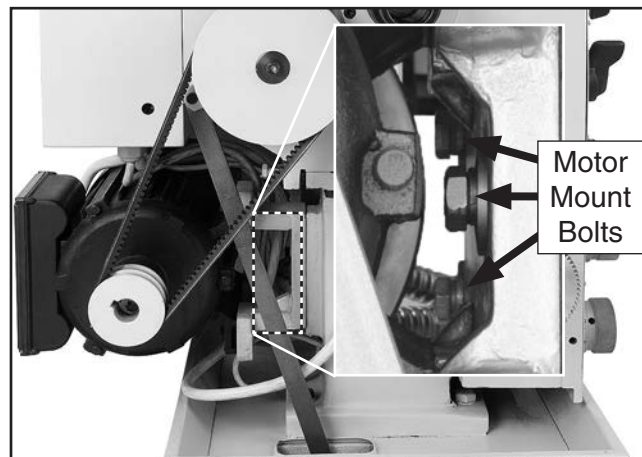
### To check the V-belt tension:

1. **DISCONNECT LATHE FROM POWER!**
2. Remove the headstock gear cover.
3. Push the center of the V-belts with moderate pressure. The V-belt deflection should be approximately 1/4".



**Figure 86.** Belt deflection.


—If the belt deflection is greater than 1/4", use the 24mm wrench to loosen the motor mount bolts (**Figure 87**) and slide the motor downward until the deflection is correct.



**Figure 87.** Checking V-belt deflection.

4. Tighten the bolts and recheck the belts.

# Cutting Fluid System



**! WARNING**  
**BIOLOGICAL AND POISON HAZARD!** Use the correct personal protection equipment when handling cutting fluid and by follow federal, state, and fluid manufacturer requirements to properly dispose of cutting fluid.

Located at the tailstock end of the lathe is an access cover where the pump and a cutting fluid tank are located. A screen in the chip drawer prevents large metal chips from entering the tank. The small metal chips wash down into the cutting fluid tank that is split into two chambers by means of a baffle. The first chamber allows the small chips to settle to the bottom, and lets clean cutting fluid overflow the baffle and enter the second chamber where the pump draws clean fluid. Inspect the tank often to verify that metal chips are not overflowing into the second chamber where, if left for a period of time, pump damage may occur.

**Tip:** For speedy chip removal from the tank, a metal catch basket with handles can be made to lift out the metal chip buildup in the first chamber.

Tools Needed	Qty
Phillips Screwdriver #2 .....	1
5-Gallon Drain Bucket .....	1
Drain Hose 3/8" x 4' .....	1

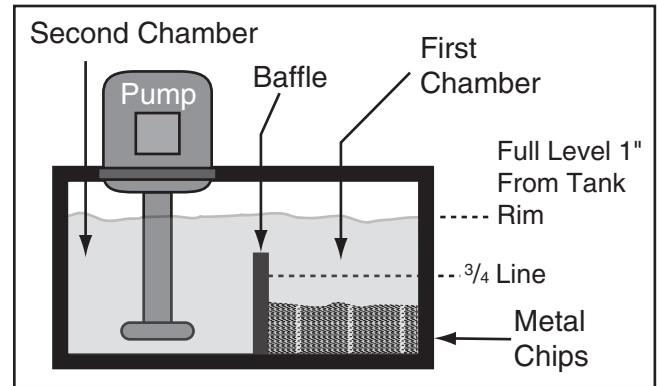
## Checking Cutting fluid System

When checking the cutting fluid system, the goal is to make sure there is enough cutting fluid, the chip level in the first chamber is not too high, and the cutting fluid has not become rancid or contaminated.

### To check the cutting fluid system:

1. DISCONNECT LATHE FROM POWER!
2. At the tailstock end of the lathe, remove the pump access cover.

3. Inspect the level of cutting fluid inside the tank. The cutting fluid should be approximately an inch below the top of the tank.
4. Using a wooden stick, check the level of the metal chips in the first chamber (see **Figure 88**). If the chips are 3/4 the height of the baffle, then remove the chips.



**Figure 88.** Diagram of cutting fluid tank.

5. Inspect the cutting fluid quality as outlined by the fluid manufacturer and replace as recommended.

## Cleaning Cutting fluid System

1. Place the drain hose on the end of the coolant nozzle, and pump the used cutting fluid into the drain bucket. As soon as pumping is complete turn **OFF** pump immediately.
2. DISCONNECT LATHE FROM POWER!
3. Lift the tank assembly from the lathe stand.
4. Remove all metal shavings, any remaining cutting fluid, and clean out the tank using rags and mineral spirits.
5. Clean the intake screen on the pump.
6. Re-install the cutting fluid tank into the lathe stand.
7. Mix 2.5 gallons of cutting fluid to the manufacturer's required specific gravity, and fill the cutting fluid tank with the cutting fluid.
8. Re-install the pump access cover.





# SECTION 7: SERVICE

Review the troubleshooting procedures in this section if a problem develops with your machine. If you need replacement parts or additional help with a procedure, call our Technical Support. **Note:** *Please gather the serial number and manufacture date of your machine before calling.*



## Motor & Gearbox

Symptom	Possible Cause	Possible Solution
Motor will not start.	<ol style="list-style-type: none"> <li>1. Stop button not reset.</li> <li>2. Main power panel switch is <b>OFF</b>.</li> <li>3. Circuit breaker or fuse has tripped.</li> <li>4. No voltage or open connection.</li> <li>5. Capacitor is at fault.</li> <li>6. Spindle ON/OFF switch is at fault.</li> <li>7. Power switch or magnetic contactor is at fault.</li> <li>8. Motor is at fault.</li> </ol>	<ol style="list-style-type: none"> <li>1. Reset stop button.</li> <li>2. Turn the main power panel switch <b>ON</b>.</li> <li>3. Seek an electrician to troubleshoot and repair the power supply.</li> <li>4. Test circuit, replace wires and connections as required (Refer to <b>Wiring, Page 71</b>).</li> <li>5. Replace capacitor.</li> <li>6. Replace switch.</li> <li>7. Replace power switch or magnetic contactor.</li> <li>8. Replace motor.</li> </ol>
Fuses or circuit breakers trip open.	<ol style="list-style-type: none"> <li>1. Short circuit in power cord or plug.</li> <li>2. Short circuit in motor or loose connections.</li> <li>3. Incorrect fuses or circuit breakers in power supply.</li> </ol>	<ol style="list-style-type: none"> <li>1. Inspect cord or plug for damaged insulation and shorted wires, repair or replace as required.</li> <li>2. Inspect all connections on motor for loose or shorted terminals or worn insulation. Repair as required (refer to <b>Wiring, Page 71</b>).</li> <li>3. Install correct fuses or circuit breakers.</li> </ol>
Machine is loud; belt slips when cutting. Overheats or bogs down in the cut.	<ol style="list-style-type: none"> <li>1. Excessive depth of cut.</li> <li>2. RPM or feed rate wrong for operation.</li> <li>3. Dull bit.</li> <li>4. Belt is slipping.</li> <li>5. Belt is at fault.</li> </ol>	<ol style="list-style-type: none"> <li>1. Decrease depth of cut.</li> <li>2. Refer to RPM feed rate chart for appropriate rates, (<b>Page 41</b>).</li> <li>3. Sharpen or replace bit.</li> <li>4. Remove grease or oil on belt tighten belt adjustment (<b>Page 68</b>).</li> <li>5. Replace belt.</li> </ol>
Gear change levers will not shift into position.	<ol style="list-style-type: none"> <li>1. Gears not aligned in headstock.</li> </ol>	<ol style="list-style-type: none"> <li>1. Rotate spindle by hand until gear falls into place.</li> </ol>
Loud, repetitious noise coming from machine at or near the motor.	<ol style="list-style-type: none"> <li>1. Pulley set screws or keys are missing or loose.</li> <li>2. Motor fan is hitting the cover.</li> </ol>	<ol style="list-style-type: none"> <li>1. Inspect keys and set screws. Replace or tighten if necessary.</li> <li>2. Replace fan and cover as required.</li> </ol>



## Operation & Work Results



Symptom	Possible Cause	Possible Solution
Entire machine vibrates excessively upon startup and while running.	<ol style="list-style-type: none"> <li>1. Workpiece is unbalanced.</li> <li>2. Worn or broken gear present.</li> <li>3. Chuck or faceplate has become unbalanced.</li> <li>4. Spindle bearings at fault.</li> </ol>	<ol style="list-style-type: none"> <li>1. Re-install workpiece so it is as centered with spindle centerline.</li> <li>2. Inspect gears and replace if necessary.</li> <li>3. Rebalance chuck or faceplate; contact a local machine shop for help.</li> <li>4. Adjust or replace spindle bearings.</li> </ol>
Cutting tool or machine components vibrate excessively during cutting.	<ol style="list-style-type: none"> <li>1. Tool holder not tight enough.</li> <li>2. Cutting tool sticks too far out of tool holder; lack of support.</li> <li>3. Gibs are out of adjustment.</li> <li>4. Dull cutting tool.</li> <li>5. Incorrect spindle speed or feed rate.</li> </ol>	<ol style="list-style-type: none"> <li>1. Check for debris, clean, and retighten.</li> <li>2. Re-install cutting tool so no more than <math>\frac{1}{3}</math> of the total length is sticking out of tool holder.</li> <li>3. Tighten gib screws at affected slide (<b>Page 59</b>).</li> <li>4. Replace or re sharpen cutting tool.</li> <li>5. Use the recommended spindle speed or feed rate (<b>Page 41</b>).</li> </ol>
Can't remove tapered tool from tailstock quill.	<ol style="list-style-type: none"> <li>1. Quill had not retracted all the way back into the tailstock.</li> <li>2. Debris is binding arbor in quill.</li> <li>3. Incorrect arbor or tooling inserted into quill.</li> </ol>	<ol style="list-style-type: none"> <li>1. Turn the quill handwheel until it forces taper out of quill.</li> <li>2. Extend quill to expose drift slot and use drift key to remove arbor.</li> <li>3. Remove quill and drive out tooling or arbor with punch.</li> </ol>
Cross slide, compound rest, or carriage feed has sloppy operation.	<ol style="list-style-type: none"> <li>1. Gibs are out of adjustment.</li> <li>2. Handwheel is loose or has excessive backlash.</li> <li>3. Leadscrew mechanism worn or out of adjustment.</li> </ol>	<ol style="list-style-type: none"> <li>1. Tighten gib (<b>Page 59</b>).</li> <li>2. Tighten screws and adjust backlash (<b>Page 61</b>).</li> <li>3. Tighten any loose fasteners on leadscrew mechanism.</li> </ol>
Cross slide, compound rest, or carriage feed handwheel is hard to move.	<ol style="list-style-type: none"> <li>1. Gibs are loaded up with shavings or grime.</li> <li>2. Gibs are too tight, gib lock or carriage lock is applied.</li> <li>3. Backlash setting too tight (cross slide only).</li> <li>4. Bedways are dry.</li> </ol>	<ol style="list-style-type: none"> <li>1. Remove gibs, clean ways/dovetails, lubricate, and readjust gibs.</li> <li>2. Loosen gib adjustment and gib locks, release carriage lock (<b>Page 59</b>).</li> <li>3. Slightly loosen backlash setting (<b>Page 61</b>).</li> <li>4. Lubricate bedways and handles.</li> </ol>
Bad surface finish.	<ol style="list-style-type: none"> <li>1. Wrong RPM or feed rate.</li> <li>2. Dull tooling or poor tool selection.</li> <li>3. Too much play in gibs.</li> <li>4. Tool too high.</li> </ol>	<ol style="list-style-type: none"> <li>1. Adjust for appropriate RPM and feed rate.</li> <li>2. Sharpen tooling or select a better tool for the intended operation.</li> <li>3. Tighten gibs (<b>Page 59</b>).</li> <li>4. Lower the tool position.</li> </ol>
Inaccurate turning results from one end of the workpiece to the other.	<ol style="list-style-type: none"> <li>1. Headstock and tailstock are not properly aligned with each other.</li> </ol>	<ol style="list-style-type: none"> <li>1. Realign the tailstock to the headstock spindle bore center line (<b>Page 36</b>).</li> </ol>
Chuck jaws won't move or don't move easily.	<ol style="list-style-type: none"> <li>1. Chips lodged in the jaws.</li> </ol>	<ol style="list-style-type: none"> <li>1. Remove jaws, clean and lubricate chuck threads, and replace jaws.</li> </ol>
Carriage won't auto feed, or overloads the spindle motor.	<ol style="list-style-type: none"> <li>1. Carriage or gib lock is applied.</li> <li>2. Gears are not all engaged or broken.</li> <li>3. Gibs are too tight.</li> <li>4. Leadscrew shear pin has sheared.</li> </ol>	<ol style="list-style-type: none"> <li>1. Release locks.</li> <li>2. Adjust gear positions or replace.</li> <li>3. Loosen gib screw(s) slightly (<b>Page 59</b>).</li> <li>4. Correct the cause of shear pin breakage, and replace shear pin.</li> </ol>
Tailstock quill will not feed out of tailstock.	<ol style="list-style-type: none"> <li>1. Quill lock lever is tightened down.</li> </ol>	<ol style="list-style-type: none"> <li>1. Turn lever counterclockwise.</li> </ol>



# Gib Adjustments

The cross-slide and compound slide on this lathe each use a long steel wedge called a gib that is positioned between the component and its dovetailed-ways. At the end of each gib is a gib screw one of which is shown in **Figure 89**. The screws at each end of the gib oppose one another to move and hold the gib in a forward or aft position. Depending which direction the gib is moved and held, the space between the sliding ways is increased or decreased to control the rigidity of the cross slide and compound slide.

Before adjusting gibs, consider the lathe operation that you will perform because the cross slide and compound rest leadscrew nuts may also have to be adjusted.

- For heavy turning and facing loads, tighten gibs for maximum rigidity, and loosen the leadscrew nuts for shock loading protection.
- For high-tolerance turning and facing, and light-loads, loosen the gibs to allow for small slide movements without binding or tool bit leap, and tighten the leadscrew nuts for fine handwheel control.

Most lathe operations exist between the two examples above. Finding the optimum combination for your requirements may take practice, and trial and error before you are satisfied.

## NOTICE

**When adjusting gibs, keep in mind that the goal of gib adjustment is to remove unnecessary sloppiness from the slide without causing binding and excessive half nut wear.**

**Tip:** *The compound and cross slide gibs have a gib lock screw that are shown in **Figures 89–90**. This screw allows the machinist to quickly tighten the locks to hold a gib and slide in a rigid position without having to tighten the gibs. When finished with the need for increased rigidity, the gibs then are quickly unloaded back to their normal state by loosening the screw.*

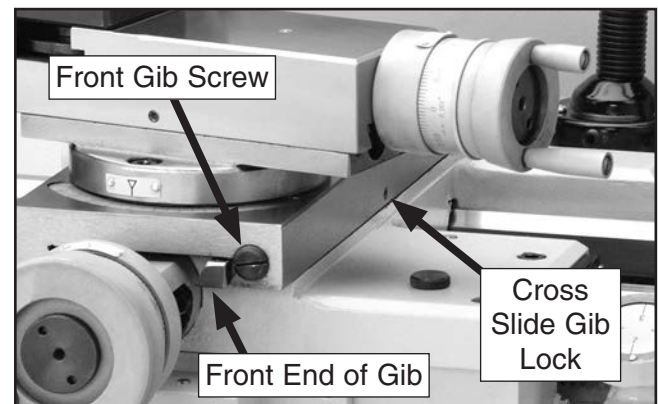
Tools Needed	Qty
Standard Screwdriver #2.....	1
Wrench 10mm .....	1
Hex Wrench 3mm.....	1

## Cross Slide Gib

Make sure the ways and leadscrew have been cleaned and re-lubricated before beginning any adjustments. Refer to **Ball Oiler Lubrication** on **Page 52** for instructions and lubricant specifications.

### To adjust the cross slide gib:

1. DISCONNECT LATHE FROM POWER!
2. Loosen the gib lock shown in **Figure 89**.



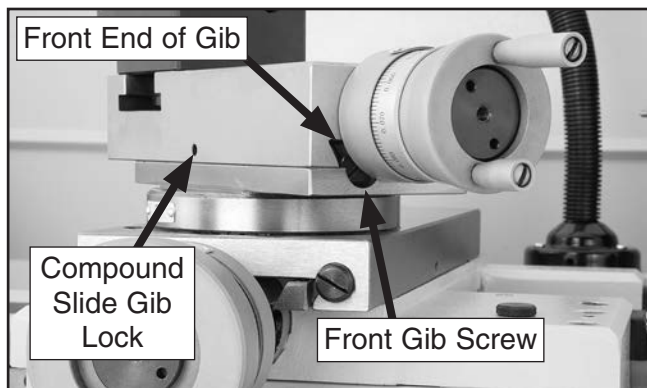
**Figure 89.** Cross slide gib components.

3. Loosen gib screw and adjust as required.
  - To increase the slide tension, loosen the rear gib screw  $\frac{1}{8}$ -turn, and tighten the front gib screw  $\frac{1}{8}$ -turn.
  - To decrease the slide tension, loosen the front gib screw  $\frac{1}{8}$ -turn, and tighten the rear gib screw  $\frac{1}{8}$ -turn.
4. Repeat adjustments as necessary until the gib screw drag is acceptable.



## Compound Slide Gib

**Figure 90** shows the gib arrangement for the compound slide. The compound slide gib adjusts in the same manner and with the same tools as the cross slide gib. However, in this case, to increase or decrease tension, the gib adjustment screw directions are reversed.

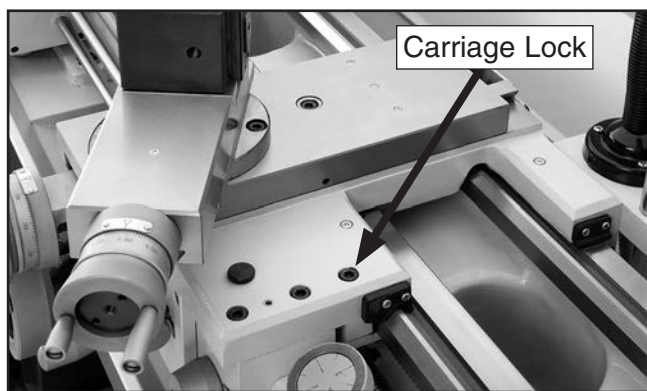


**Figure 90.** Compound slide gib components.

## Saddle Gib

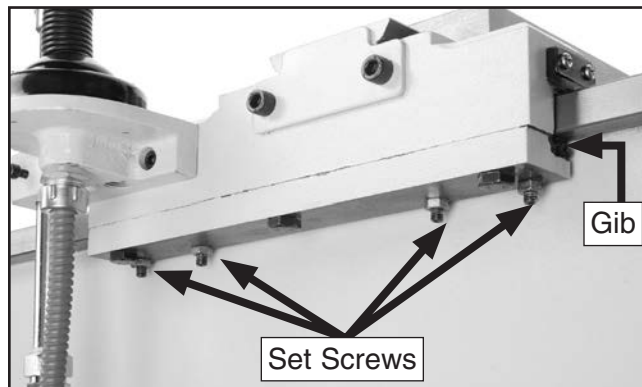
The saddle is supplied with a carriage lock on the front right-hand side of the slide (see **Figure 91**). This bolt locks the saddle in place for increased rigidity when making face cuts. Before making adjustments to the saddle gib, make sure that this lock is loose by turning it counterclockwise one full turn.

**IMPORTANT:** *Do not loosen the carriage lock more than a couple of turns or the components inside will come apart. Re-installing these components is difficult and time consuming.*



**Figure 91.** Location of carriage lock.

The saddle gib is located on the bottom of the back edge of the slide (**Figure 92**). This gib is designed differently than the cross or compound slide gibs. Instead of being a wedge-shaped plate, it is a flat bar. The gib pressure is applied by four set screws. Hex nuts secure these set screws in place, so they will not loosen during operation.



**Figure 92.** Saddle gib components.

### Tools Needed

Tools Needed	Qty
Wrench 10mm .....	1
Hex 3mm .....	1
Hex 6mm .....	1

### To adjust the saddle slide gib:

1. DISCONNECT LATHE FROM POWER!
2. Clean and lubricate the lathe ways, slide, and leadscrew (refer to **Ball Oiler Lubrication** on **Page 52** for instructions and lubricant specifications).
3. If the carriage lock (**Figure 87**) is tight, loosen it two turns.
4. Loosen the jam nuts on the four set screws shown in **Figure 92**, and adjust the set screws as follows:
  - To tighten the carriage gib, tighten the set screws.
  - To loosen the gib, loosen the set screws.
5. Repeat adjustments as necessary until the carriage adjustment is acceptable.
6. Hold the set screws in place and tighten the jam nuts.



# Backlash Adjustment

Backlash is the amount of play in a leadscrew and can be felt as the free play in a handwheel when changing direction of rotation. The amount of the backlash can be viewed on the handwheel micrometer-collar.

When adjusting backlash, tighten the components enough to remove backlash, but not so much that the components bind the leadscrew, making it hard to turn. Overtightening will cause excessive wear to the sliding block and leadscrew.

Tools Needed	Qty
Hex Wrench 6mm.....	1
Hex Wrench 5mm.....	1

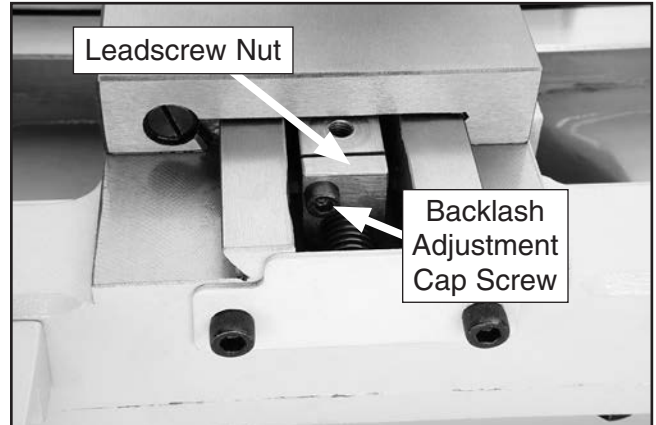
## To adjust the cross slide backlash:

1. Feed the cross slide backwards (toward the front of the machine) until it reaches the end of its travel.
2. Remove the cap screw that secures the cross slide leadscrew nut (see **Figure 93**).



**Figure 93.** Location of cap screw that secures the leadscrew nut.

3. Rotate the cross slide handle clockwise to feed the leadscrew nut out from under the cross slide, as shown in **Figure 94**.



**Figure 94.** Leadscrew nut.

4. Tighten the backlash adjustment cap screw shown in **Figure 94** in small increments.
5. Hold the leadscrew nut and test after each adjustment by rotating the handwheel back-and-forth until the backlash amount is acceptable.
6. Feed the leadscrew nut back under the cross slide and replace the cap screw removed in **Step 2**.





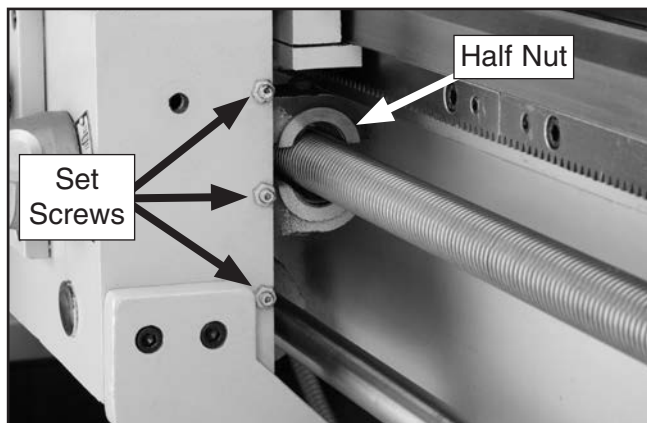
# Half Nut Adjustment

The half-nut mechanism can be adjusted if it becomes loose from wear. The half nut is mounted in ways with a gib exerting pressure between components to reduce sloppy movement. The half-nut gib is a flat bar-type gib, similar to the saddle gib, and is tensioned with three set screws.

Tools Needed	Qty
Hex Wrenches 2.5, 6mm.....	1 Each
Wrench 8mm .....	1

## To adjust the half nut:

1. DISCONNECT LATHE FROM POWER!
2. Open the half nut and remove the thread dial.
3. Loosen the hex nuts on the set screws shown in **Figure 95**.



**Figure 95.** Half nut gib set screws.

4. Tighten each set screw approximately  $\frac{1}{8}$  of a turn, then retighten the hex nuts without moving the set screws.
5. Move the carriage handwheel until the half nut can fully close, then open/close the half nut several times and notice how it feels. The half nut is correctly adjusted when you feel a slight drag while opening and closing it. It should not feel too stiff or too loose.
6. Repeat **Steps 3–5**, if necessary, until you are satisfied with the half nut adjustment, then re-install the thread dial.

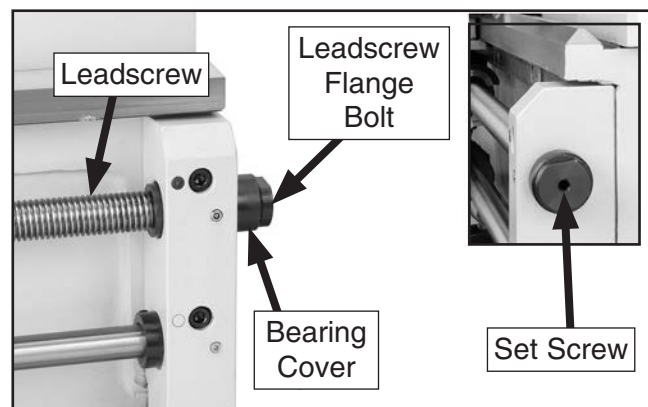
# Leadscrew Endplay Adjustment

After a long period of time, you may find that the leadscrew develops a bit of end play. This lathe is designed so that play can be removed with a simple adjustment.

Tools Needed	Qty
Hex Wrench 3mm.....	1
Wrench 24mm .....	1

## To remove leadscrew end play:

1. DISCONNECT LATHE FROM POWER.
2. Back out the leadscrew set screw approximately five turns (see **Figure 96**).



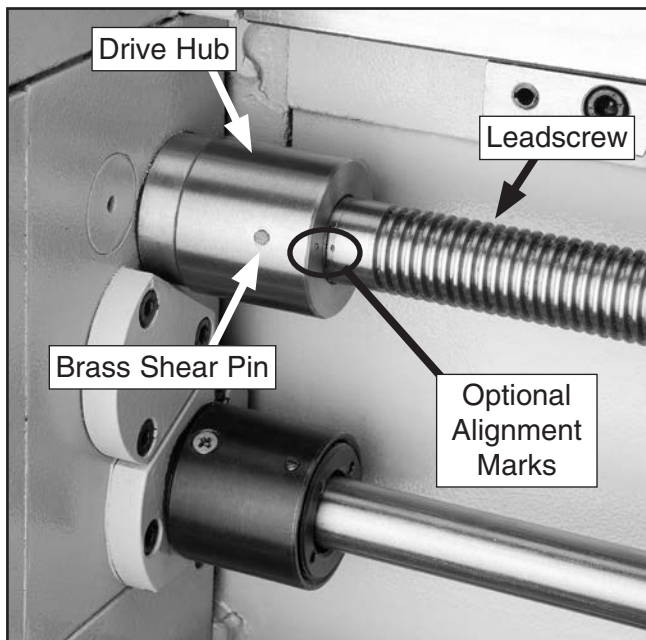
**Figure 96.** Leadscrew end play bearings.

3. Un-thread the leadscrew flange bolt (**Figure 96**), and slide the bearing cover off the end of the leadscrew.
4. Clean the bearings with minerals spirits, then dry and repack them with Grade GL2 bearing grease. Re-install the bearing cover.
5. With your left hand, pull the leadscrew toward the tailstock, and thread the leadscrew flange bolt back on until it is finger tight and no leadscrew end play exists.
6. Hold the leadscrew flange bolt with the 24mm wrench, and tighten the set screw until it is snug at the bottom of its bore.



# Shear Pin Replacement

A straight 4 x 42mm brass shear pin (**Figure 97**) holds the leadscrew and the drive hub together. The pin is designed to shear and help protect the lathe drivetrain from damage if an overload is encountered.



**Figure 97.** Leadscrew shear pin.

For example, the pin may shear if the carriage path is obstructed during threading, the tool bit crashes into a workpiece shoulder, the carriage lock is left applied when the half nut is engaged, or too deep of a cut is taken, causing a sudden binding of the tool and workpiece.

It is imperative to recognize, however, that the shear pin is not a foolproof way of protecting your lathe from damage if an operational mistake is made, a chuck-carriage crash occurs, or general machine overloading occurs on a regular basis.

Always have a few extra pins on hand in case of an emergency. If a replacement is not on hand, do not improvise by inserting a roll pin, cotter pin, steel dowel, or nail. Doing so will void the warranty, and can lead to a non-shearing pin, resulting in catastrophic gearbox damage.

Tools Needed	Qty
Hammer.....	1
Dowel Punch $\frac{3}{16}$ ".....	1
Drill Bit $\frac{1}{8}$ ".....	1
Hand Drill.....	1
Wood Screw #8 x 1" (or longer).....	1
Pointed Center Punch.....	1
Standard Pliers.....	1

## To replace the shear pin:

1. DISCONNECT LATHE FROM POWER!
2. Unlock the half-nut lever and disengage the gearbox so the leadscrew can be rotated by hand.
3. Rotate the drive hub, and inspect it to see if the pin is still stuck in both sides of it.

—If one half of the shear pin has fallen out and the leadscrew shaft can be seen through the pin hole, rotate the leadscrew and until the end of the inner sheared pin can be seen. Next, insert the  $\frac{3}{16}$ " dowel punch into the hole and tap the pin out through the other side.

—If the shear pin halves are still stuck in both sides of the drive hub, center punch one of pins and drill an  $\frac{1}{8}$ " hole in the pin approximately  $\frac{1}{4}$ " deep. Next, thread the #8 wood screw into the hole until the screw begins to thread into the brass. Using pliers, pull the pin from the hole, and drive the rest of the pin out as outlined above.

4. Align the holes in the drive hub with the hole in the leadscrew, and tap the new shear pin into position until it is flush.

**Tip:** For easy shear pin replacement in the future, use the center punch or a scribe and mark the end of the drive hub and the side of the leadscrew with a timing mark to indicate where true hole alignment is located. Next, scribe a line on the leadscrew just where it enters the drive hub, this line will indicate correct depth of leadscrew. Should the pin ever shear again, line-up the marks, and drive out the pin pieces, and tap in the new pin.

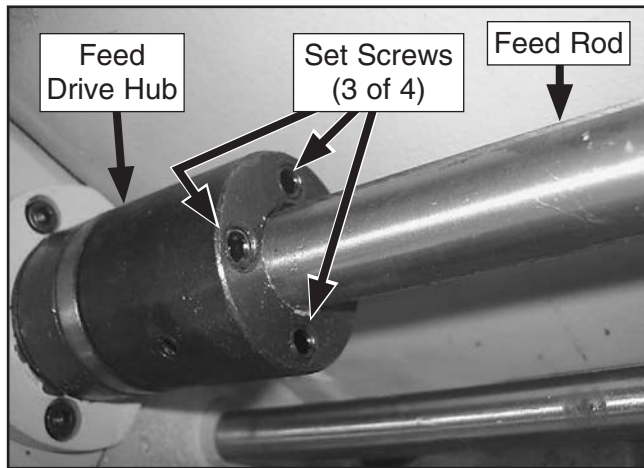


# Feed Rod Clutch Adjustment

Tool Needed	Qty
Hex Wrench 6mm.....	1

## To adjust feed rod clutch:

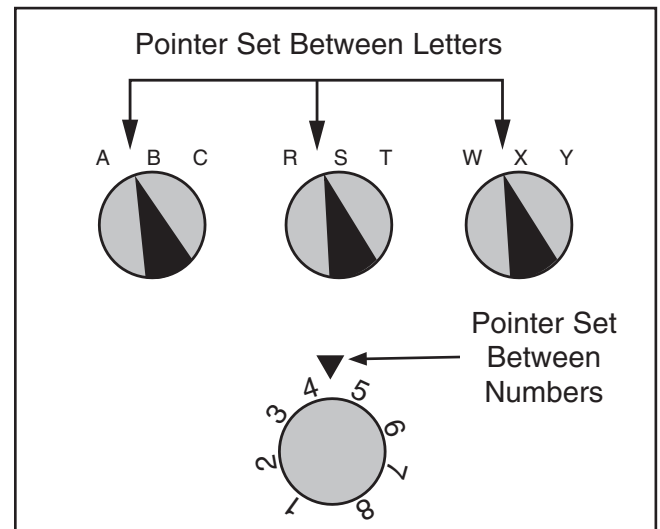
1. DISCONNECT MACHINE FROM POWER!
2. Position top feed-speed dial pointers between letters, then position bottom gearbox dial pointer between numbers (see **Figure 107**). This allows feed rod to move freely so adjustments can be made to the clutch.



**Figure 106.** Feed rod clutch.

The clutch may slip if the path for the carriage or the cross feed is obstructed during turning or facing operations, the tool bit crashes into a workpiece shoulder, the carriage lock is incorrectly tightened when the feed selection lever is engaged, or if too deep of a cut is taken—causing a sudden binding of the tool and workpiece.

NEVER completely tighten the feed clutch past its normal setting in an attempt to completely eliminate clutch slip. Doing so will void the warranty, and can lead to a non-slipping clutch, resulting in catastrophic gearbox damage.



**Figure 107.** Gearbox dial settings for feed clutch adjustment.

—If clutch slips during normal work loads, increase clutch spring pressure by tightening each of the four clutch-drive set screws (shown in **Figure 106**) one full turn, then recheck for slippage.

—If clutch does NOT slip when it should, reduce clutch spring pressure by loosening each of the four clutch-drive set screws one full turn, then recheck for slippage.



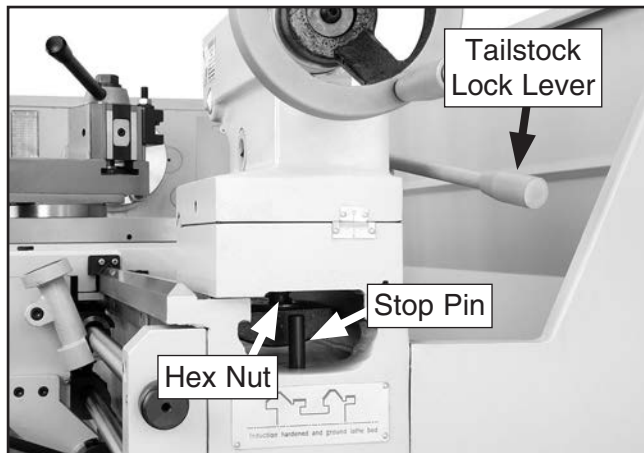
# Tailstock Lock

When pushed toward the spindle, the tailstock lock holds the tailstock firmly in place on the bedway with a locking plate underneath. If the position of the lock lever is difficult to use, the lever can be adjusted for the best leverage.

Tools Needed	Qty
Wrench 24mm .....	1

## To adjust the tailstock lock lever:

1. Unthread the stop pin (see **Figure 98**), and carefully slide the tailstock from the lathe.



**Figure 98.** Tailstock locking hex nut and plate.

2. Tighten the hex nut  $\frac{1}{4}$ -turn and re-install the tailstock.
3. Apply the tailstock lock lever and verify that the tailstock is locked and the lever is where desired. Readjust as necessary.

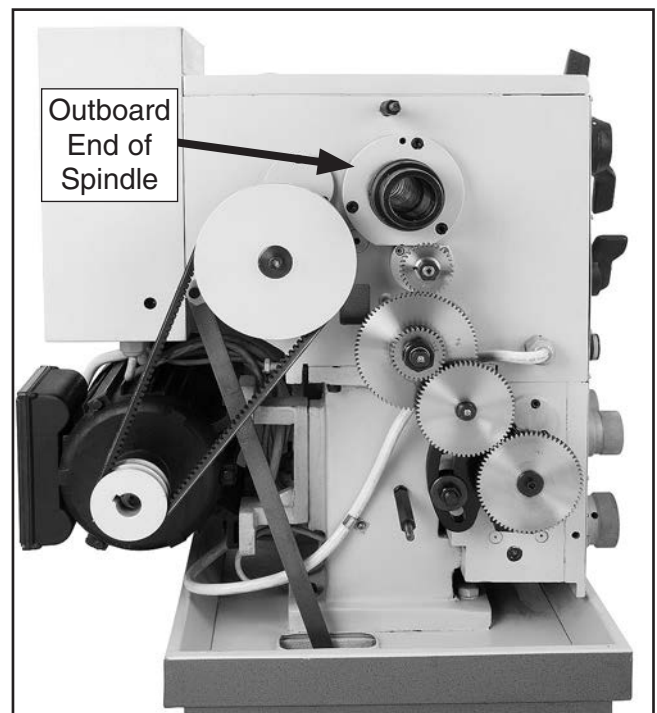
# Bearing Preload

This lathe is shipped from the factory with the spindle bearing preload set. If the spindle ever develops end-play and the workpiece finish suffers, you can re-establish the bearing preload, remove the end-play, and correct the workpiece finish issue.

Tools Needed	Qty
Hook-Style Spanner Wrench 68-75mm.....	1
Dial Indicator with Magnetic Base .....	1
Heavy Dead Blow Hammer .....	1
Wooden Block .....	1

## To adjust the preload:

1. Run the lathe for 20 minutes on high speed to bring the lathe to a normal temperature.
2. DISCONNECT LATHE FROM POWER!
3. Remove the chuck and spider bolts, then shift the spindle to neutral and remove the headstock gear cover to access the outboard end of the spindle (see **Figure 99**).

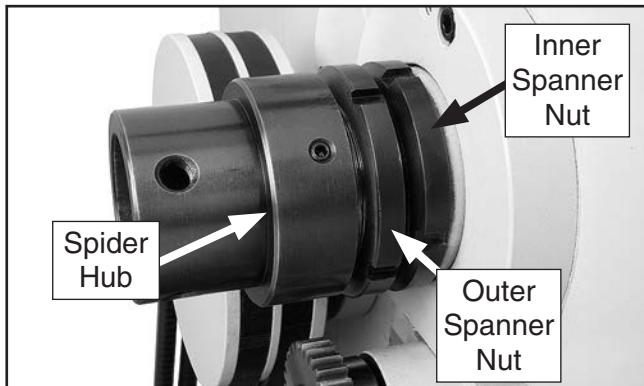


**Figure 99.** Location of outboard end of spindle.





- Place the chuck wrench in the cam-lock socket to keep the spindle from rotating, and loosen the outer spanner nut (see **Figure 100**) two turns. Removing the spider hub is not necessary.



**Figure 100.** Spindle spanner nuts.

- Loosen the inner spanner nut one turn. If the spanner nut is too difficult to break loose easily, you may have to tap on the outboard spindle tube as explained in **Step 6** to help unseat the spindle bearings.

## ***NOTICE***

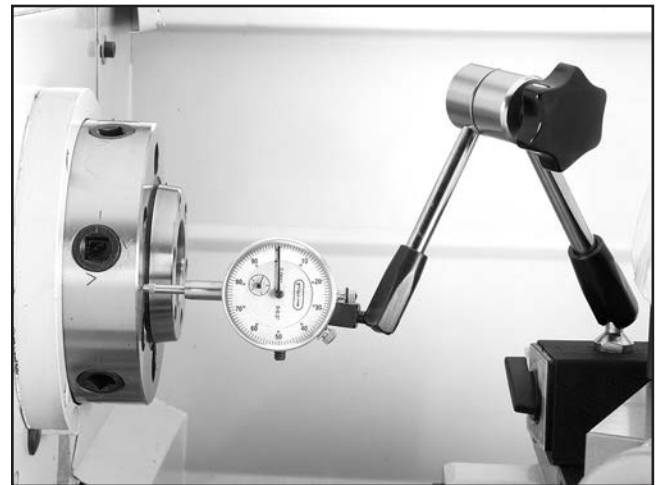
For the next step, **DO NOT** strike the wooden block with excessive force. If you do, you can cause the tapered roller bearings to indent the mating races. If this damage occurs, one or more spindle bearings will have to be replaced, as this damage will generate vibration at higher spindle speeds.

- Since the spindle bearings may unseat easily without great force, hold a wood block against the outboard end of the spindle, and tap the block a few times with a three or four pound hammer (see **Figure 101**). Your goal is to slide the spindle forward just enough to introduce spindle end-play that can be heard or felt by hand.



**Figure 101.** Un-seating spindle bearings to introduce spindle end-play.

- Place a dial indicator on the cross slide and move the carriage toward the headstock until the contact point of the indicator touches the spindle face (see **Figure 102**).



**Figure 102.** Dial indicator setup.

- Move the carriage an additional 0.100" toward the headstock, and zero the dial indicator.





9. Insert the chuck wrench into a cam socket to prevent the spindle from turning, then tighten the inner spanner nut until the dial indicator needle just stops moving (see **Figure 103**).

While tightening the spanner nuts, rock the spindle back and forth slightly with the cam key to make sure the spindle tapered roller bearings seat properly in their races.

When the dial indicator needle stops moving, there will be zero spindle end-play and no bearing preload. It is essential that you find this point without tightening the spanner nut too much and inadvertently pre-load the spindle bearings.



**Figure 103.** Adjusting spindle bearings.

Since it takes great effort to turn the inner spanner nut, you may find it difficult to know if you have gone past the zero end-play point or not. It is easiest to have someone watch the dial while you tighten the inner spanner nut. If you think you may have gone past the zero end-play point, take the time to unload the bearings as described earlier, then re-tighten the inner spanner nut until it has reached the zero end play position.

10. Tighten the spanner nut an additional  $\frac{1}{16}$ -turn.

11. Without allowing the inner spanner nut, to tighten any farther, tighten the outer spanner nut against the inner nut.

Do not overtighten the outer spanner nut because additional preload can force the bearings even tighter against the races in the headstock and cause the headstock to compress or crack, or the bearing may quickly fail.

**To confirm that the bearings are correctly pre-loaded:**

1. Re-attach all removed lathe components and prepare it for operation.
2. Install the chuck and tighten the jaws.
3. Set the spindle speed to its highest setting.
4. Connect the lathe to power and turn the lathe spindle **ON**.
5. Periodically shutting down the lathe a few times and checking temperature, let the lathe run for 20 minutes.
6. Turn the spindle **OFF**, disconnect lathe from power, and check the temperature of the spindle.

—If the spindle nose is slightly warm to the touch, you have correct bearing preload.

—If the spindle nose is hotter than you can comfortably keep your hand on, the preload is too tight and you must repeat the bearing preload adjustment procedure. When repeating the procedure, rotate the inner spanner nut a little less during **Step 10** in the preceding instructions.

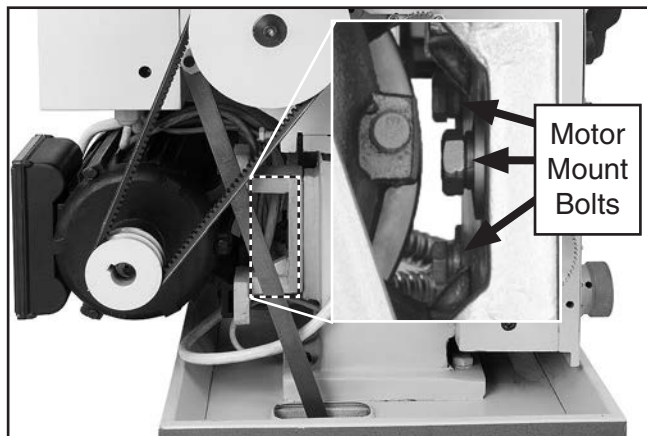


# V-Belt Replacement

Tools Needed	Qty
Phillips Screwdriver #2 .....	1
Wrench 17mm.....	1

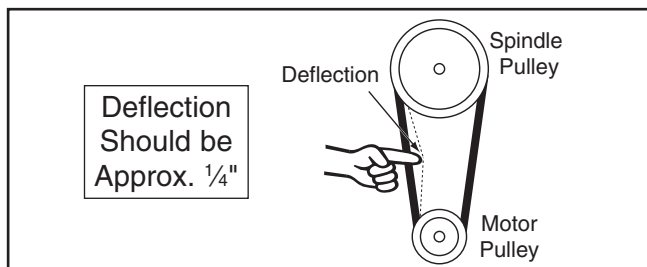
## To replace the V-belts on the lathe:

1. DISCONNECT LATHE FROM POWER!
2. Remove the headstock gear cover.
3. Loosen the motor mount bolts shown in **Figure 104**, and slide the motor up, remove the belts.



**Figure 104.** Location of motor mount bolts.

4. Install the new belts as a matched set so they equally share the load.
5. Push down on the motor with one hand to tension the belts.
6. Tighten the motor mount bolts and check the belt deflection, as shown in **Figure 105**, and re-adjust if necessary.



**Figure 105.** Belt deflection.

7. Replace the headstock gear cover.

# Brake Shoes

If the brake responds poorly, verify that the all linkage is tight and that the belts are tight and free of oil or grease. Replace the brake shoe set if the lining thickness is  $\frac{3}{16}$ " or less. When inspecting for amount of brake wear measure from the following locations:

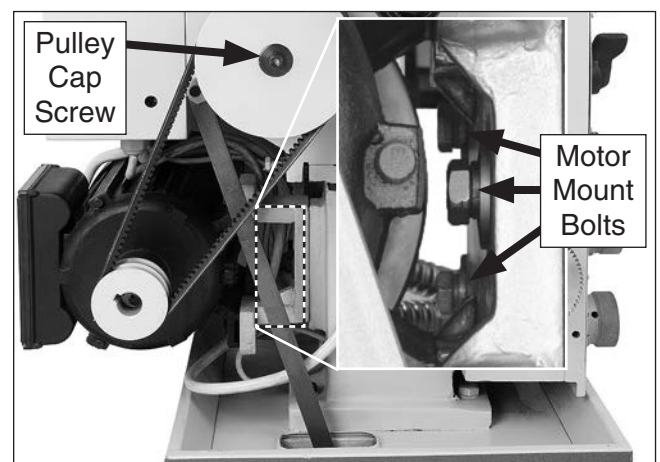
- If riveted linings are used, the measurement is taken from the rivet heads to the lining surface as viewed from the brake pad surface.
- If bonded linings are used, the measurement is taken from the metal shoe surface to the surface of the lining as viewed from the side of the brake shoe.

When inspecting the drum, if the drum pulley is bell-mouthed, cracked, or shows deep groves, replace it. For minor scoring, the drum pulley can be dressed with sandpaper or turned on a lathe.

Tools Needed	Qty
Hex Wrench 5mm.....	1
Wrench 17mm.....	1
Needle-Nose Pliers .....	1
Basic Caliper .....	1

## To check/replace the brake linings:

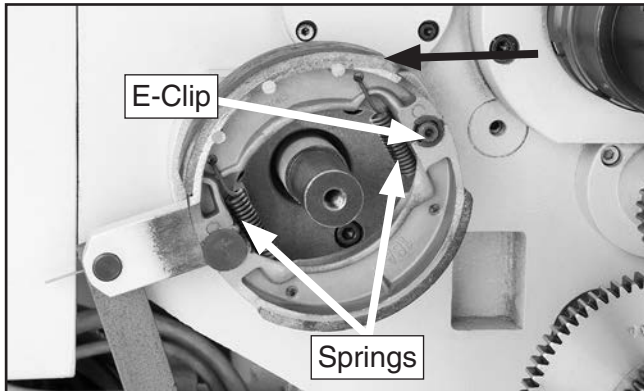
1. DISCONNECT LATHE FROM POWER!
2. Remove the headstock gear cover.
3. Loosen the motor mount bolts (**Figure 106**) and remove the belts.



**Figure 106.** Pulley cap screw.



4. Have another person step on the brake pedal to lock the pulley in place, and remove the pulley cap screw shown in **Figure 106**.
5. Step off the brake pedal and remove the pulley. **Figure 107** shows the pulley removed and the brake shoes exposed.



**Figure 107.** Brake assembly.

6. Using your calipers, measure the thickness of the brake linings.
  - If the linings are thicker than  $\frac{3}{16}$ " as described earlier, then replacement is not required. Re-assemble the lathe in the opposite manner as outlined in **Steps 2–5**.
  - If linings are oil-soaked from over lubrication of the adjacent gearing, clean and properly lubricate the gears as outlined in **Maintenance on Page 52**. Then proceed to **Step 7**.
  - If the brakes linings are  $\frac{3}{16}$ " or thinner, proceed to **Step 7**.
7. Put on safety glasses and remove the E-clip, springs, and brake shoes shown in **Figure 107**.
8. Replace or dress the drum pulley as required.
9. Install the brake shoes, springs, and E-clip.
10. Install the pulley and re-assemble in the opposite manner that you disassembled it in **Steps 2–5**.
11. Start the lathe and test the brake operation.

## Machine Storage

If the machine is not properly prepared for storage, it may develop rust or corrosion. Use the recommendations in this section to ensure that the lathe remains in good condition for later use.

### To prepare your machine for short-term storage (up to a year):

1. Pump out the old cutting fluid, and remove and blow out lines with compressed air and a few drops of way oil.
2. **DISCONNECT LATHE FROM POWER!**
3. Thoroughly clean all unpainted, bare metal surfaces, then apply a liberal coat of way oil.
4. Lubricate the machine as outlined in the lubrication section. Be sure to use the oil gun to purge all ball oilers and the oil passages with oil.
5. Cover and place the machine in a dry area that is out of direct sunlight and away from hazardous fumes, paint, solvents, or gas. Fumes and sunlight can bleach or discolor paint and make plastic guards cloudy.
6. Once or twice a month, depending on the ambient humidity levels in the storage environment, wipe down the machine as outlined in **Step 3**. Slide the carriage, tailstock, and steady rest down the lathe bed to make sure that way spotting is not beginning to occur.
7. Every few months, manually rotate all gear-driven components a few times in several gear selections. This will keep the bearings, bushings, gears, and shafts well lubricated and protected from corrosion, especially during the winter months.



**To prepare your machine for long-term storage (a year or more):**

1. Run the lathe and bring all gearboxes to operating temperature, then drain and refill the all gearboxes with fresh oil.
2. Pump out the old cutting fluid, remove the lines, add a few drops of way oil into the lines, and blow out the lines with compressed air.
3. **DISCONNECT LATHE FROM POWER!**
4. Thoroughly clean all unpainted, bare metal surfaces, then apply a liberal coat of way oil, a heavy grease, or rust preventative. Take care to ensure these surfaces are completely covered but that the rust preventative or grease is kept off of painted surfaces.
5. Lubricate the machine as outlined in the lubrication section. Be sure to use the oil gun to purge all ball oilers and the oil passages with oil.
6. Loosen or remove machine belts so they do not become stretched during the storage period. (Be sure to also affix a maintenance note near the power button as a reminder that the belts have been loosened or removed.)
7. Place a few moisture-absorbing desiccant bags inside of the electrical box.
8. Cover and place the machine in a dry area that is out of direct sunlight and away from hazardous fumes, paint, solvents, or gas. Fumes and sunlight can bleach or discolor paint and make plastic guards cloudy.
9. Slide the carriage, micrometer stop, tailstock, and steady rest down the lathe bed to make sure that way spotting is not beginning to occur.



# SECTION 8: WIRING

These pages are current at the time of printing. However, in the spirit of improvement, we may make changes to the electrical systems of future machines. Compare the manufacture date of your machine to the one stated in this manual, and study this section carefully.

If there are differences between your machine and what is shown in this section, call Technical Support at (570) 546-9663 for assistance BEFORE making any changes to the wiring on your machine. An updated wiring diagram may be available. **Note:** *Please gather the serial number and manufacture date of your machine before calling. This information can be found on the main machine label.*

## WARNING

### Wiring Safety Instructions

**SHOCK HAZARD.** Working on wiring that is connected to a power source is extremely dangerous. Touching electrified parts will result in personal injury including but not limited to severe burns, electrocution, or death. Disconnect the power from the machine before servicing electrical components!

**MODIFICATIONS.** Modifying the wiring beyond what is shown in the diagram may lead to unpredictable results, including serious injury or fire. This includes the installation of unapproved after-market parts.

**WIRE CONNECTIONS.** All connections must be tight to prevent wires from loosening during machine operation. Double-check all wires disconnected or connected during any wiring task to ensure tight connections.

**CIRCUIT REQUIREMENTS.** You MUST follow the requirements at the beginning of this manual when connecting your machine to a power source.

**WIRE/COMPONENT DAMAGE.** Damaged wires or components increase the risk of serious personal injury, fire, or machine damage. If you notice that any wires or components are damaged while performing a wiring task, replace those wires or components.

**MOTOR WIRING.** The motor wiring shown in these diagrams is current at the time of printing but may not match your machine. If you find this to be the case, use the wiring diagram inside the motor junction box.
















**CAPACITORS/INVERTERS.** Some capacitors and power inverters store an electrical charge for up to 10 minutes after being disconnected from the power source. To reduce the risk of being shocked, wait at least this long before working on capacitors.

**EXPERIENCING DIFFICULTIES.** If you are experiencing difficulties understanding the information included in this section, contact our Technical Support at (570) 546-9663.

#### NOTICE

The photos and diagrams included in this section are best viewed in color. You can view these pages in color at [www.grizzly.com](http://www.grizzly.com).

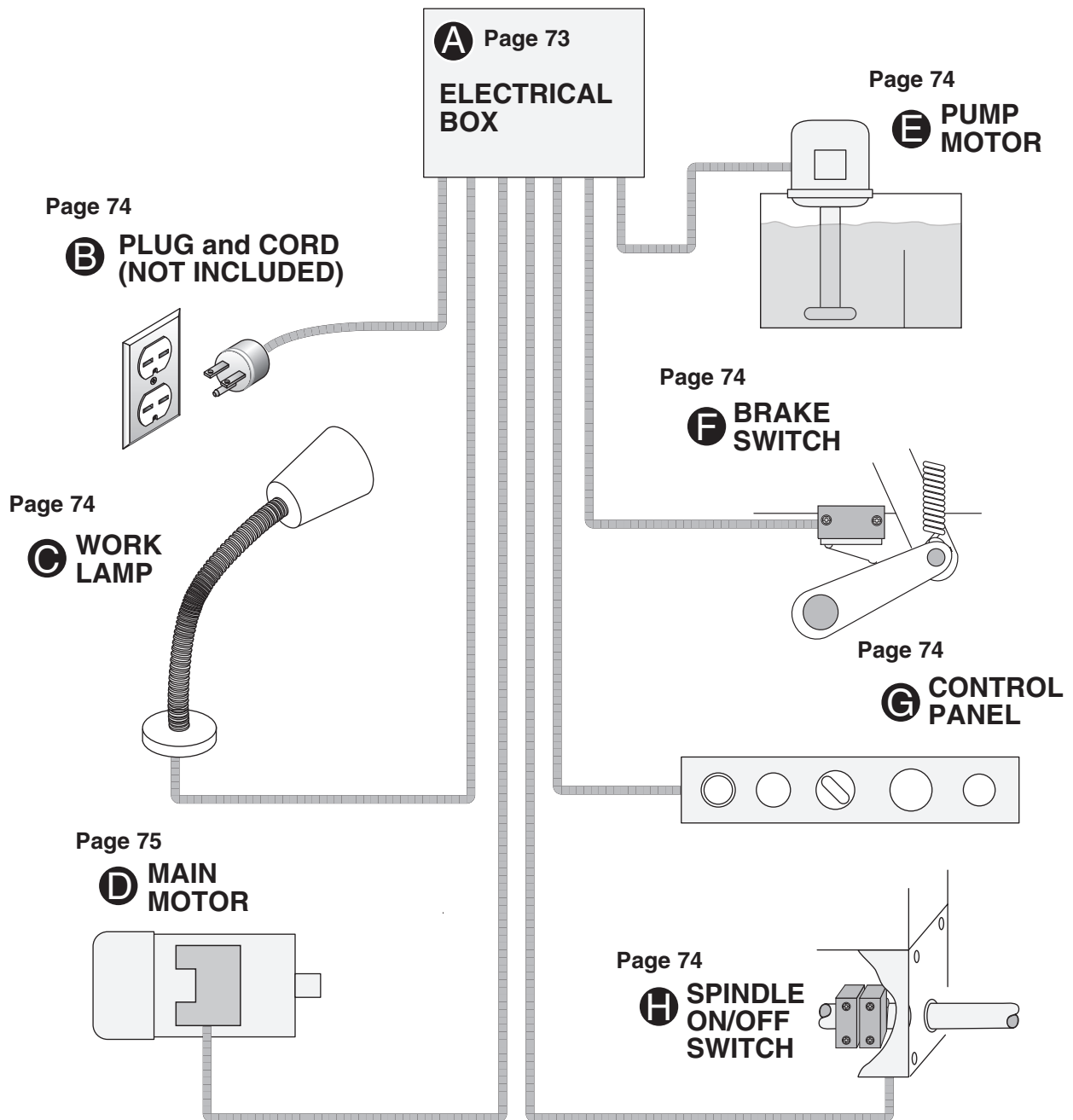
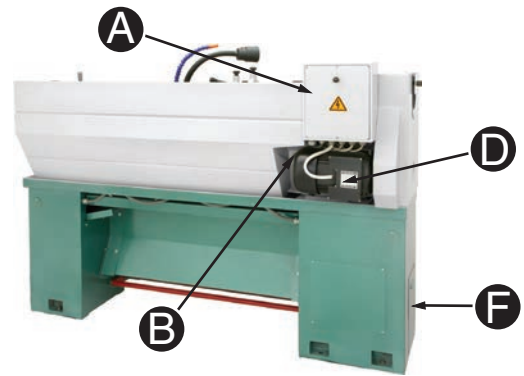
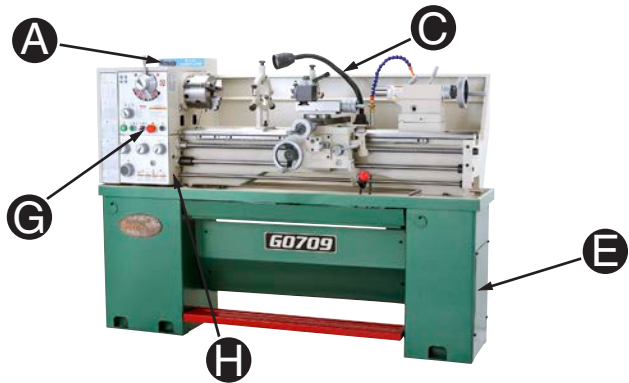
#### COLOR KEY

BLACK 	BLUE 	YELLOW 	LIGHT BLUE 
WHITE 	BROWN 	YELLOW GREEN 	BLUE WHITE 
GREEN 	GRAY 	PURPLE 	TURQUOISE 
RED 	ORANGE 	PINK 	

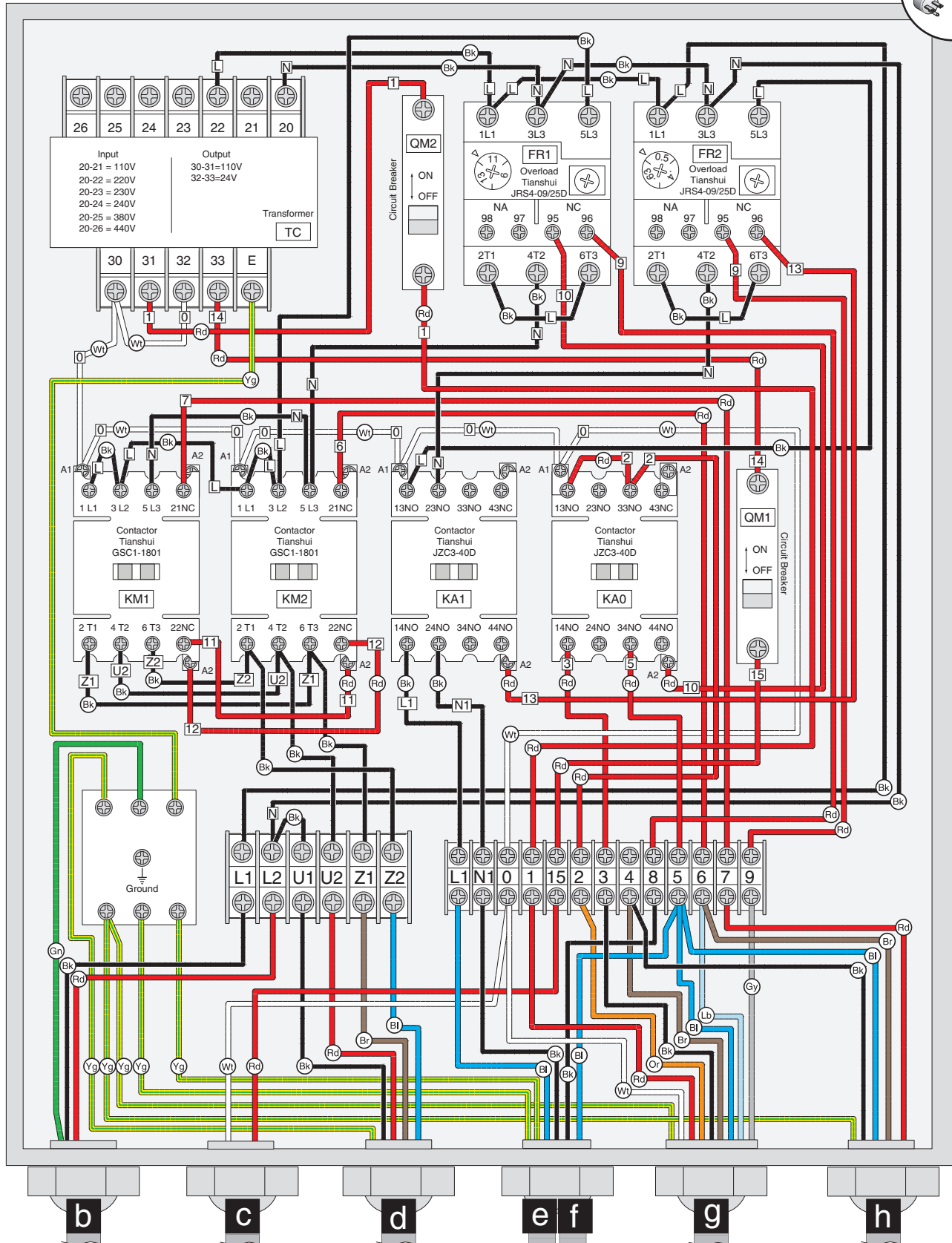




# Wiring Overview



# Electrical Box Wiring



To Page 74

To Page 75

To Page 74

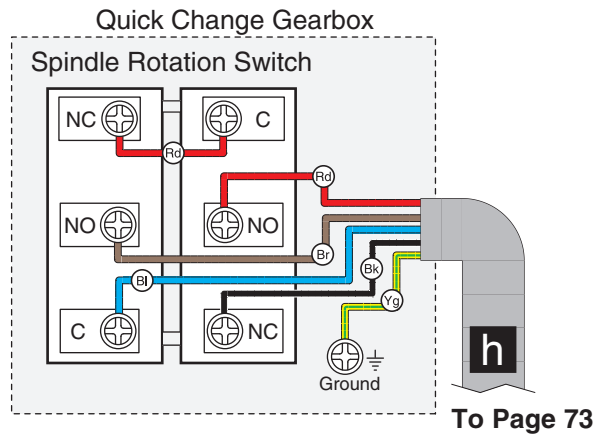
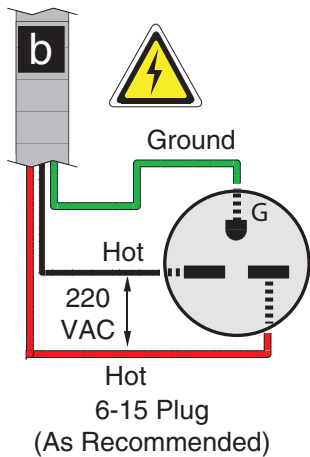
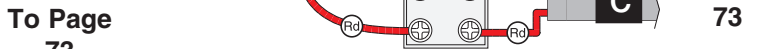
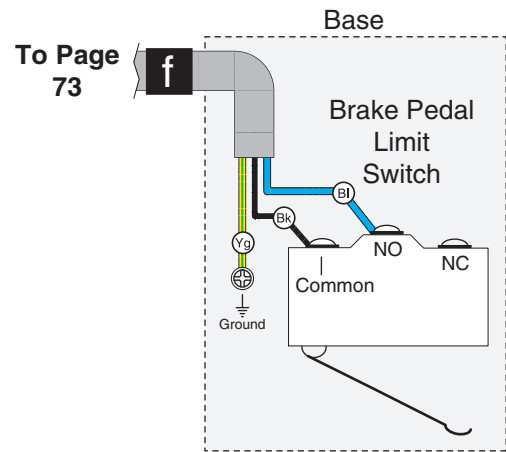
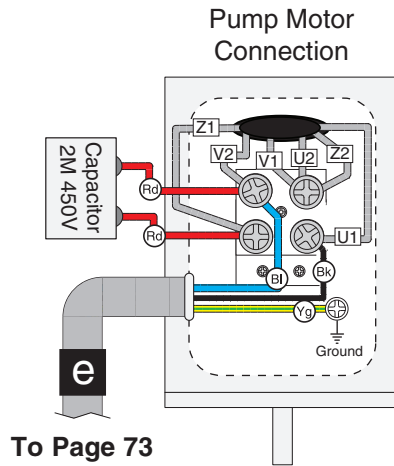
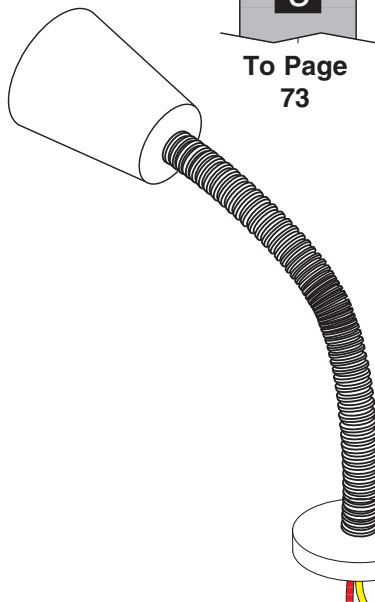
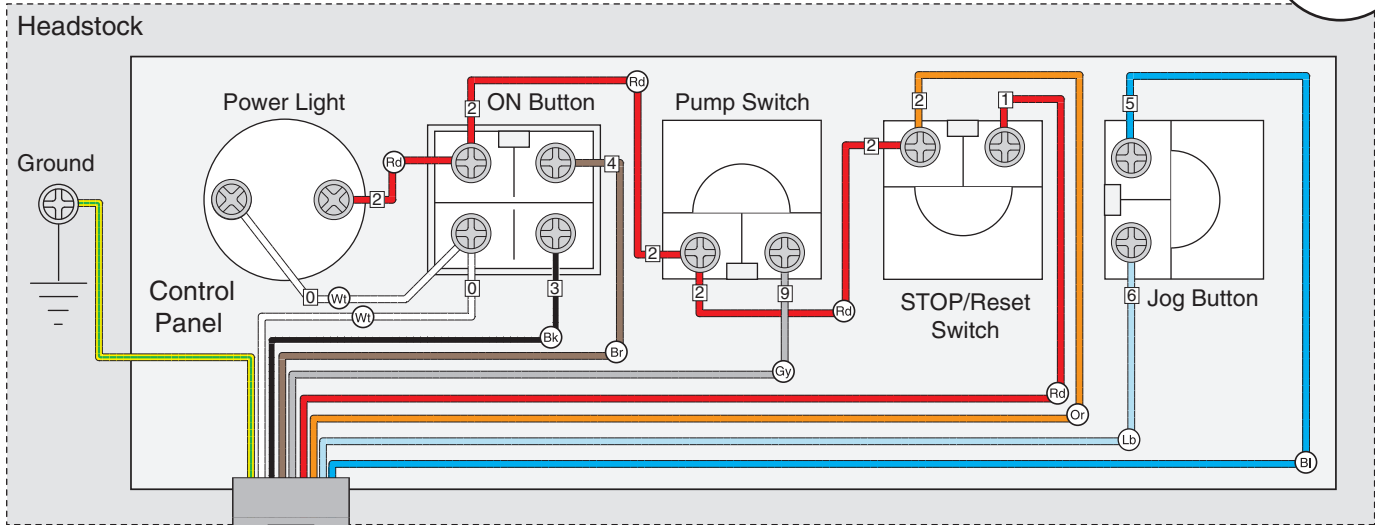
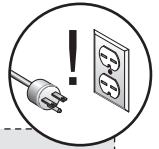
To Page 74

To Page 74

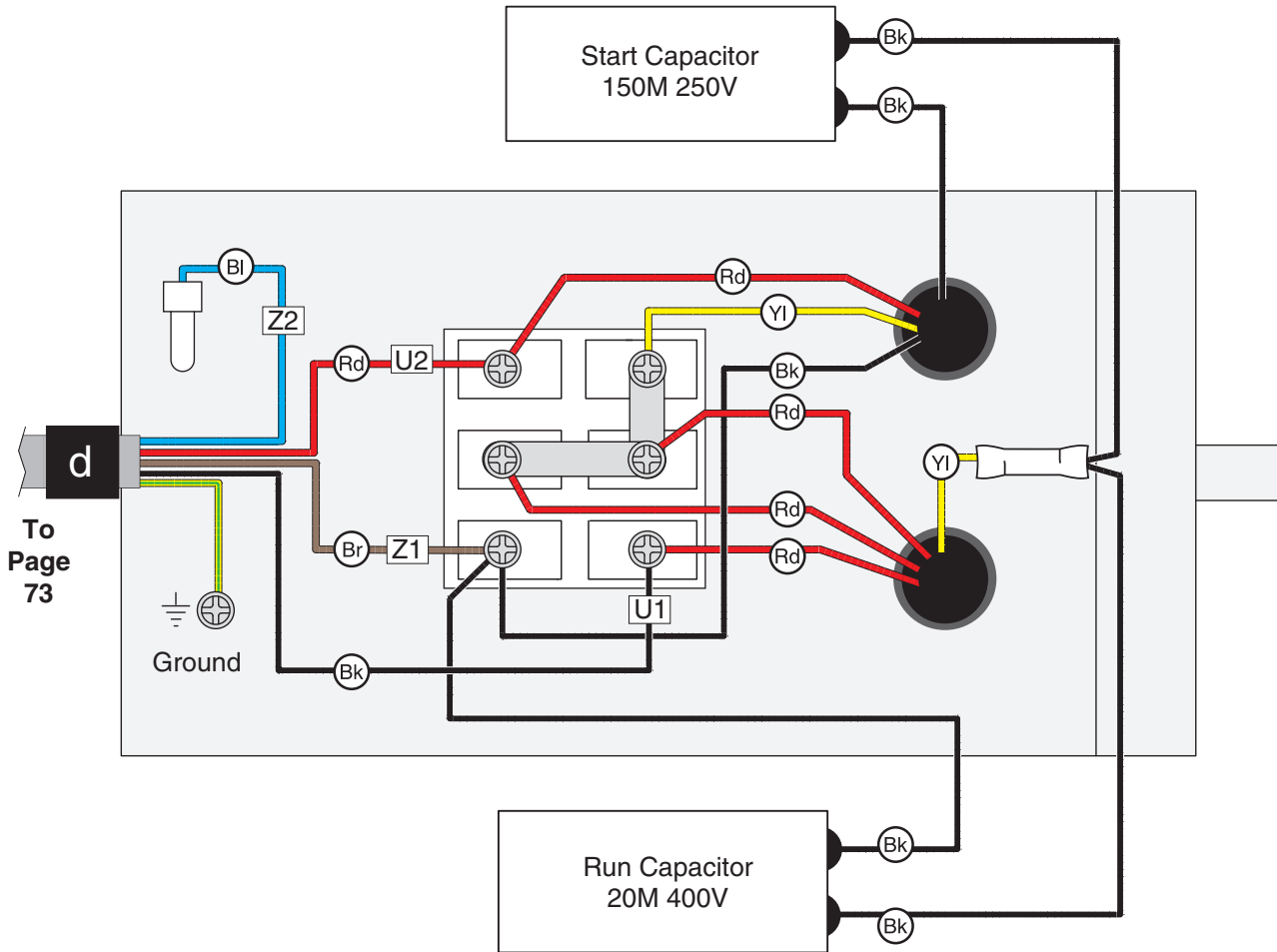
To Page 74



# Switches and Pump Motor



# Spindle Motor Connection



## MOTOR DIRECTION

### NOTICE

If the lathe chuck rotates in the opposite direction of what the spindle ON/OFF lever indicates, disconnect the lathe from power. At the motor junction box, swap the positions of the wires marked U<sub>1</sub> and U<sub>2</sub>. This will match the motor and spindle rotation to what is indicated at the spindle ON/OFF lever.





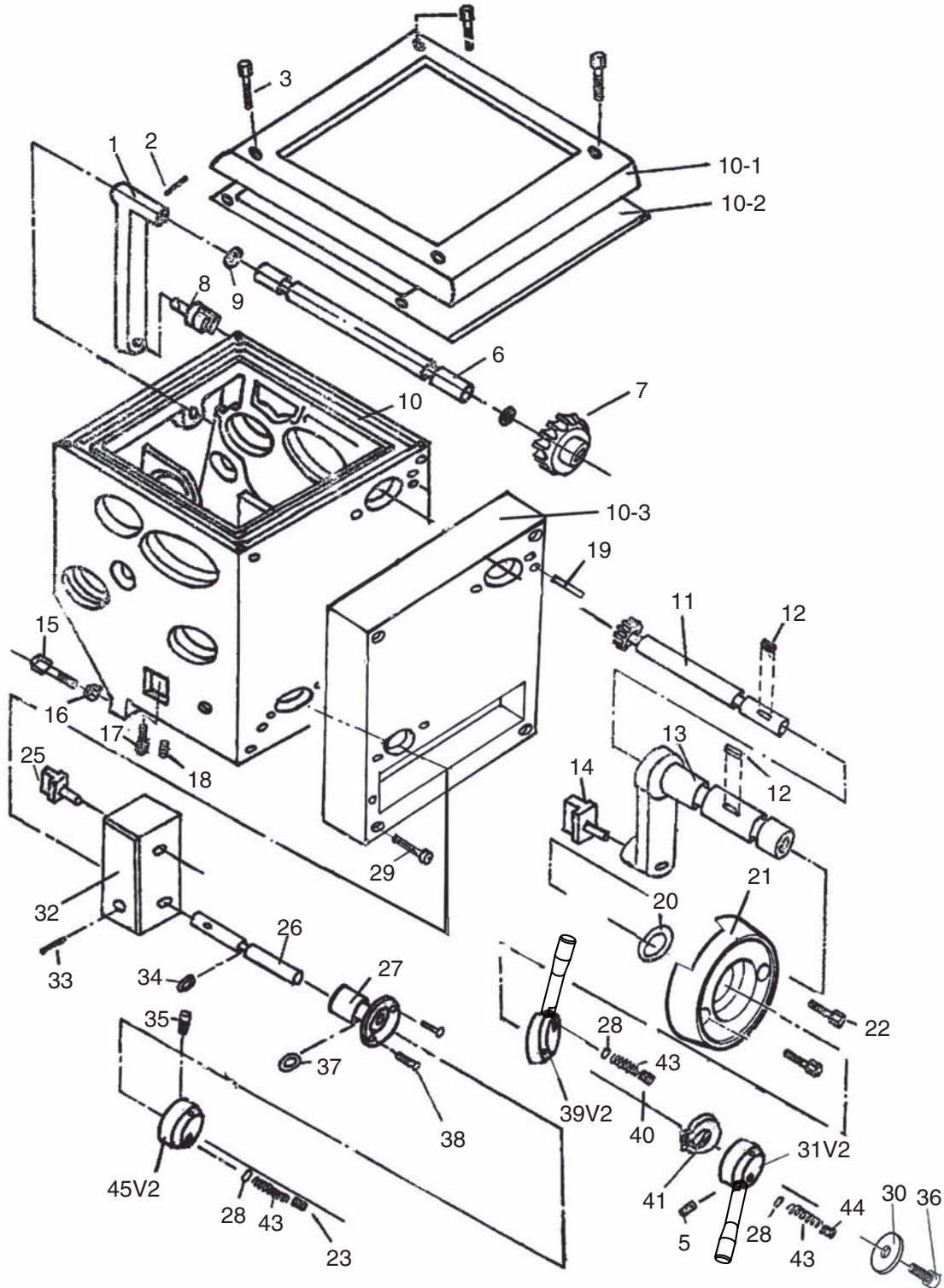
# Electrical Box Photo





# SECTION 9: PARTS

## Headstock Case and Shift



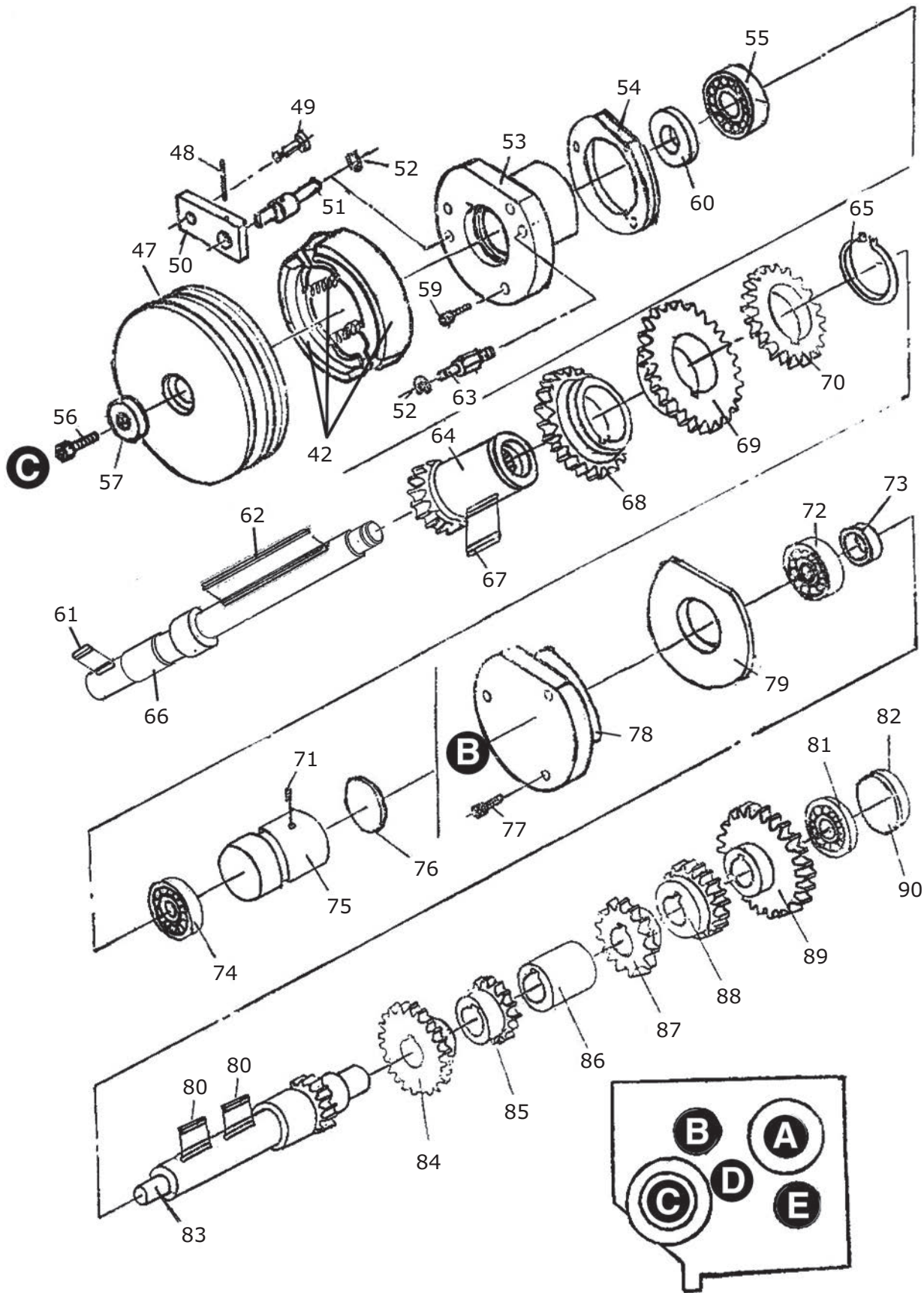
# Headstock Parts List

REF	PART #	DESCRIPTION
1	P07090001	SHIFT LEVER
2	P07090002	ROLL PIN 5 X 32
3	P07090003	CAP SCREW M6-1 X 18
5	P07090005	SET SCREW M8-1.25 X 12
6	P07090006	SHAFT
7	P07090007	GEAR 51T
8	P07090008	SHIFT FORK
9	P07090009	O-RING 13.8 X 2.4 P14
10	P07090010	HEADSTOCK CASTING
10-1	P07090010-1	HEADSTOCK COVER
10-2	P07090010-2	GASKET
10-3	P07090010-3	HEADSTOCK FRAME
11	P07090011	GEARED SHAFT
12	P07090012	KEY 5 X 5 X 15
13	P07090013	SHIFT CRANK
14	P07090014	SHIFT CLAW
15	P07090015	CAP SCREW M8-1.25 X 45
16	P07090016	HEX NUT M8-1.25
17	P07090017	CAP SCREW M10-1.5 X 35
18	P07090018	SET SCREW M8-1.25 X 12
19	P07090019	TAPER PIN 6 X 60
20	P07090020	O-RING 30 X 3.1
21	P07090021	COVER

REF	PART #	DESCRIPTION
22	P07090022	CAP SCREW M6-1 X 35
23	P07090023	SET SCREW M6-1 X 16
25	P07090025	SHIFT CLAW
26	P07090026	SHAFT
27	P07090027	LEVER HUB
28	P07090028	STEEL BALL 6MM
29	P07090029	CAP SCREW M6-1 X 50
30	P07090030	HUB WASHER
31V2	P07090031V2	SPINDLE SPEED SHIFT LEVER V2.09.12
32	P07090032	SHIFT BLOCK
33	P07090033	ROLL PIN 4 X 18
34	P07090034	O-RING 9.8 X 1.9 P10
35	P07090004	SET SCREW M6-1 X 16
36	P07090036	FLAT HD SCR M8-1.25 X 20
37	P07090037	O-RING 19.8 X 2.4 P20
38	P07090038	CAP SCREW M4-.7 X 8
39V2	P07090039V2	HEADSTOCK RANGE SHIFT LEVER V2.09.12
40	P07090040	SET SCREW M8-1.25 X 8
41	P07090041	EXT RETAINING RING 30MM
43	P07090043	COMPRESSION SPRING
44	P07090044	SET SCREW M8-1.25 X 10
45V2	P07090045V2	FEED DIRECTION LEVER V2.09.12



# Headstock Drive



# Headstock Drive Parts List

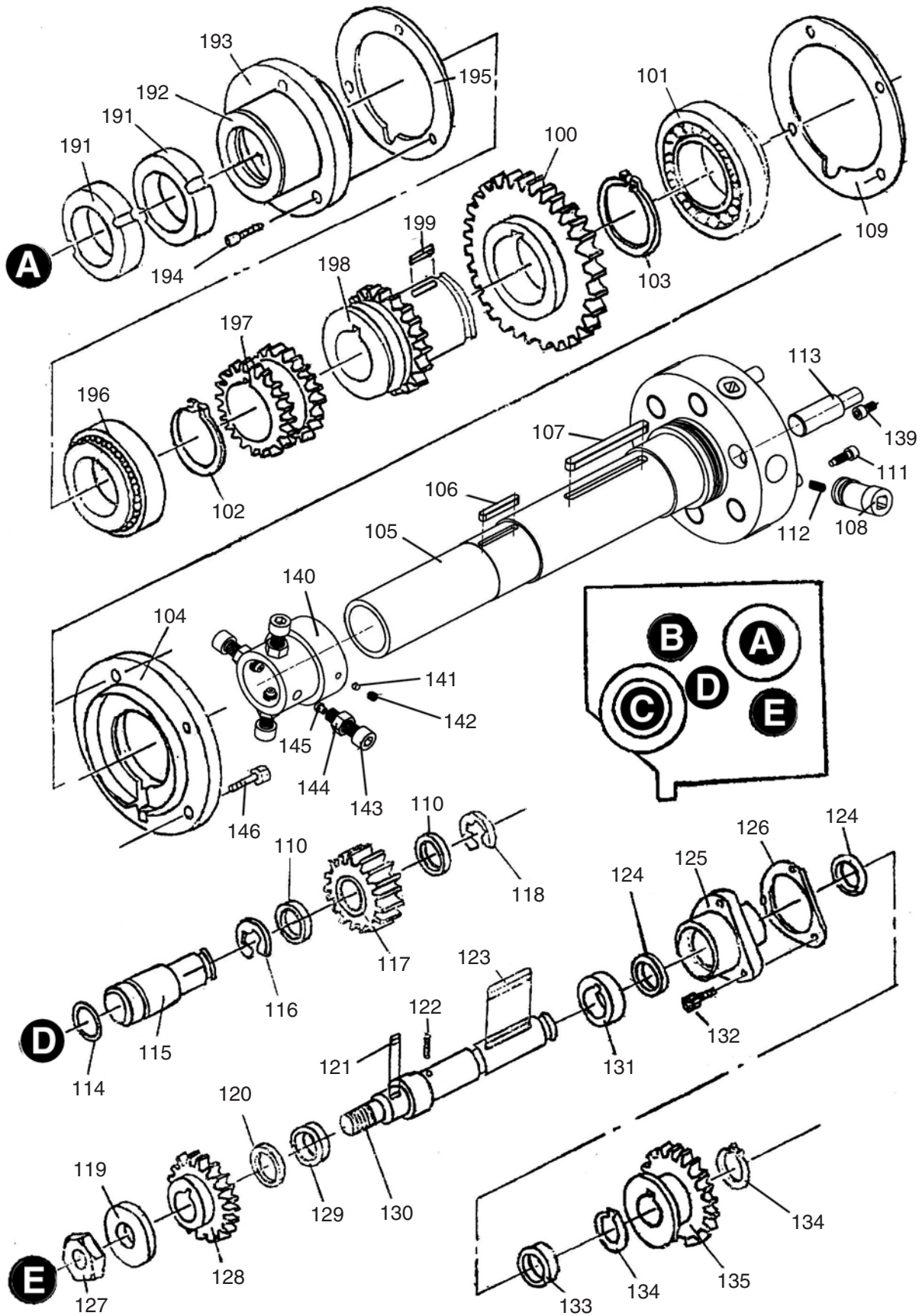
REF	PART #	DESCRIPTION
42	P07090042	BRAKE SHOE ASSEMBLY
47	P07090047	DRUM PULLEY
48	P07090048	ROLL PIN 5 X 25
49	P07090049	ANCHOR PIN
50	P07090050	ROCKER BAR
51	P07090051	ROCKER PIN
52	P07090052	EXT RETAINING RING 8MM
53	P07090053	BEARING RETAINER
54	P07090054	GASKET
55	P07090055	BALL BEARING 6005Z
56	P07090056	CAP SCREW M8-1.25 X 16
57	P07090057	SHOULDER WASHER
59	P07090059	CAP SCREW M6-1 X 16
60	P07090060	OIL SEAL
61	P07090061	KEY 8 X 8 X 20
62	P07090062	KEY 6 X 6 X 120
63	P07090063	ROCKER PIN
64	P07090064	TOOTHED COLLAR
65	P07090065	EXT RETAINING RING 35MM
66	P07090066	SHAFT
67	P07090067	KEY 5 X 5 X 50
68	P07090068	GEAR 29T

REF	PART #	DESCRIPTION
69	P07090069	GEAR 46T
70	P07090070	GEAR 38T
71	P07090071	SET SCREW M8-1.25 X 16
72	P07090072	BALL BEARING 6203Z
73	P07090073	SPACER
74	P07090074	BALL BEARING 6203ZZ
75	P07090075	FRONT PLUG
76	P07090076	O-RING 40 X 3
77	P07090077	CAP SCREW M4-.7 X 12
78	P07090078	COVER
79	P07090079	GASKET
80	P07090080	KEY 6 X 6 X 55
81	P07090081	BALL BEARING 6204 OPEN
82	P07090082	O-RING 45.7 X 3.5 P46
83	P07090083	TOOTHED SHAFT
84	P07090084	GEAR 51T
85	P07090085	GEAR 43T
86	P07090086	SPACER
87	P07090087	GEAR 26T
88	P07090088	GEAR 34T
89	P07090089	GEAR 53T
90	P07090090	FRONT PLUG





# Headstock Spindle





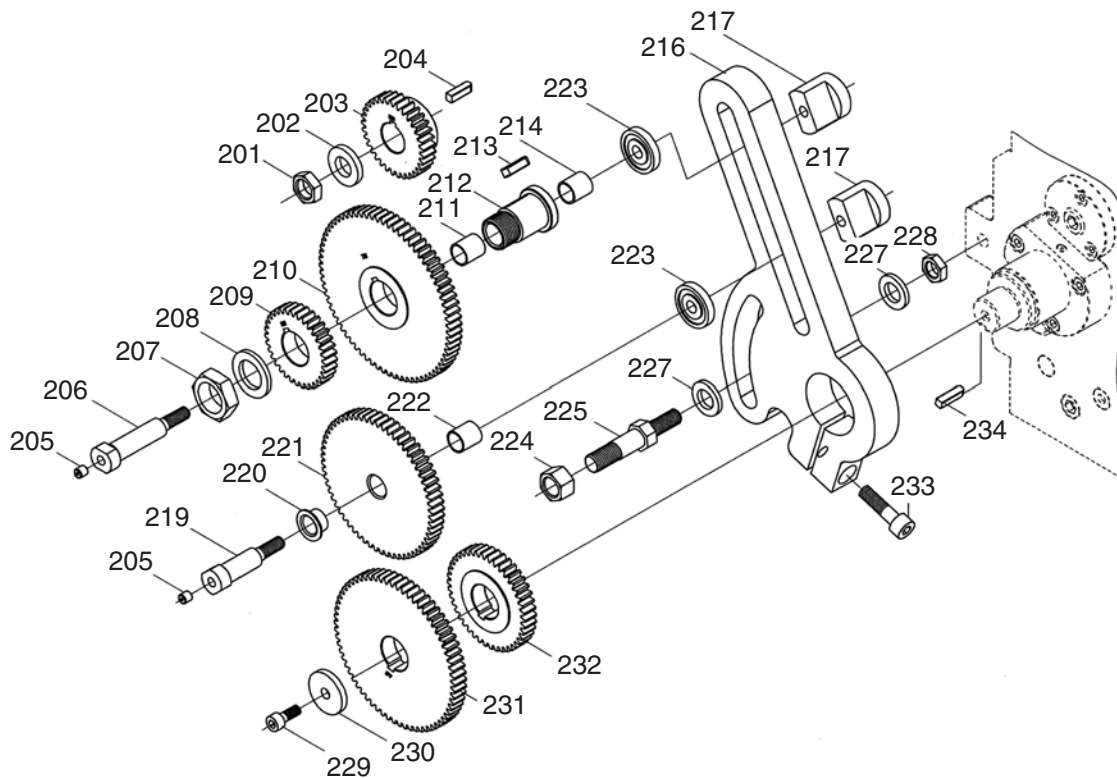
# Headstock Spindle Parts List

REF	PART #	DESCRIPTION
100	P07090100	GEAR 74T
101	P07090101	TAPERED ROLLER BEARING P30212-P5
102	P07090102	EXT RETAINING RING 50MM
103	P07090103	EXT RETAINING RING 72MM
104	P07090104	BEARING RETAINER
105	P07090105	SPINDLE
106	P07090106	KEY 6 X 6 X 40
107	P07090107	KEY 8 X 8 X 85
108	P07090108	CAM LOCK
109	P07090109	GASKET
110	P07090110	BALL BEARING 16004ZZ
111	P07090111	CAP SCREW M6-1 X 20
112	P07090112	COMPRESSION SPRING
113	P07090113	CAM LOCK STUD
114	P07090114	O-RING 23.7 X 2.5
115	P07090115	SHAFT
116	P07090116	E-CLIP 42MM
117	P07090117	GEAR 30T
118	P07090118	E-CLIP 42MM
119	P07090119	SPACER WASHER
120	P07090120	SPACER
121	P07090121	KEY 5 X 5 X 18
122	P07090122	DOWEL PIN 3 X 10
123	P07090123	KEY 6 X 6 X 50
124	P07090124	COLLAR
125	P07090125	FLANGE HUB
126	P07090126	GASKET

REF	PART #	DESCRIPTION
127	P07090127	HEX NUT M12-1.75
128	P07090128	GEAR 32T
129	P07090129	OIL SEAL
130	P07090130	SHAFT
131	P07090131	SPACER
132	P07090132	CAP SCREW M5-.8 X 16
133	P07090133	SPACER
134	P07090134	EXT RETAINING RING 20MM
135	P07090135	GEAR 37T
139	P07090139	CAP SCREW M6-1 X 12
140	P07090140	SPIDER SLEEVE
141	P07090141	BRASS CUSHION
142	P07090142	SET SCREW M6-1 X 6
143	P07090143	SPIDER SCREW M10-1.5 X 35
144	P07090144	HEX NUT M10-1.5
145	P07090145	BRASS TIP
146	P07090146	CAP SCREW M6-1 X 25
191	P07090191	SPANNER NUT
192	P07090192	COLLAR
193	P07090193	OUTBOARD COVER
194	P07090194	CAP SCREW M6-1 X 25
195	P07090195	GASKET
196	P07090196	TAPERED ROLLER BEARING P30210-P6
197	P07090197	COMBO GEAR 37T
198	P07090198	GEARED HUB 37T
199	P07090199	KEY 8 X 8 X 18



# Change Gears

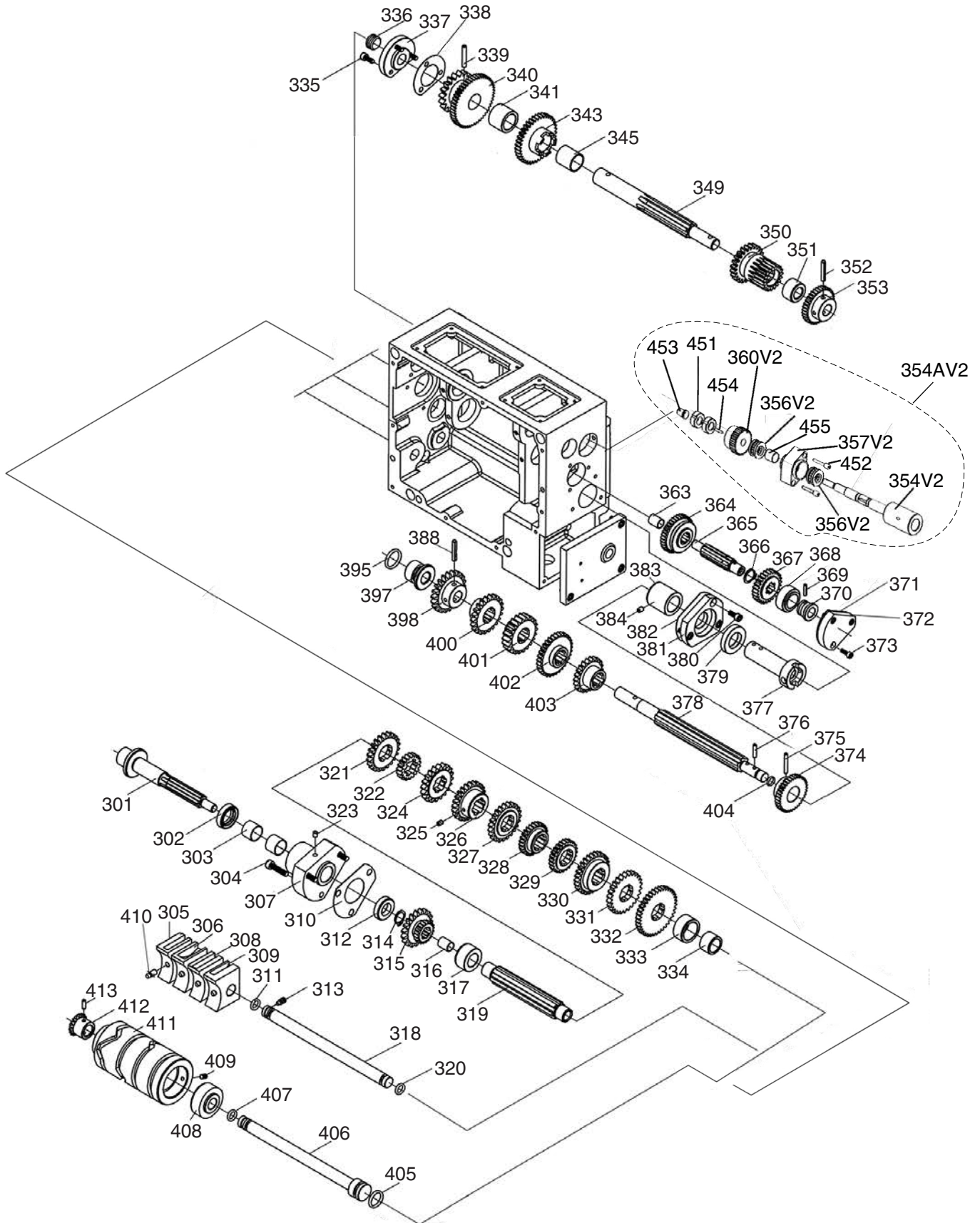


REF	PART #	DESCRIPTION
201	P07090201	HEX NUT M12-1.5
202	P07090202	FLAT WASHER 12MM
203	P07090203	CHANGE GEAR 32T
204	P07090204	KEY 5 X 5 X 18
205	P07090205	TAP-IN BALL OILER 6MM
206	P07090206	SPINDLE
207	P07090207	HEX NUT M20 X 1.5
208	P07090208	THRUST WASHER
209	P07090209	CHANGE GEAR 33T
210	P07090210	CHANGE GEAR 76T
211	P07090211	BUSHING
212	P07090212	REDUCER BUSHING
213	P07090213	KEY 5 X 5 X 20
214	P07090214	BUSHING
216	P07090216	CHANGE GEAR PIVOT BRACKET
217	P07090217	T-NUT

REF	PART #	DESCRIPTION
219	P07090219	SPINDLE
220	P07090220	BUSHING
221	P07090221	GEAR 61T
222	P07090222	BUSHING
223	P07090223	SUPPORT WASHER
224	P07090224	HEX NUT M12-1.5
225	P07090225	CLAMP SHAFT
227	P07090227	FLAT WASHER 10MM
228	P07090228	HEX NUT M10-1.5
229	P07090229	CAP SCREW M6-1 X 16
230	P07090230	FLAT WASHER 6MM
231	P07090231	CHANGE GEAR 66T
232	P07090232	CHANGE GEAR 42T
233	P07090233	CAP SCREW M8-1.25 X 30
234	P07090234	KEY 5 X 5 X 20



# Quick Change Gearbox Drive



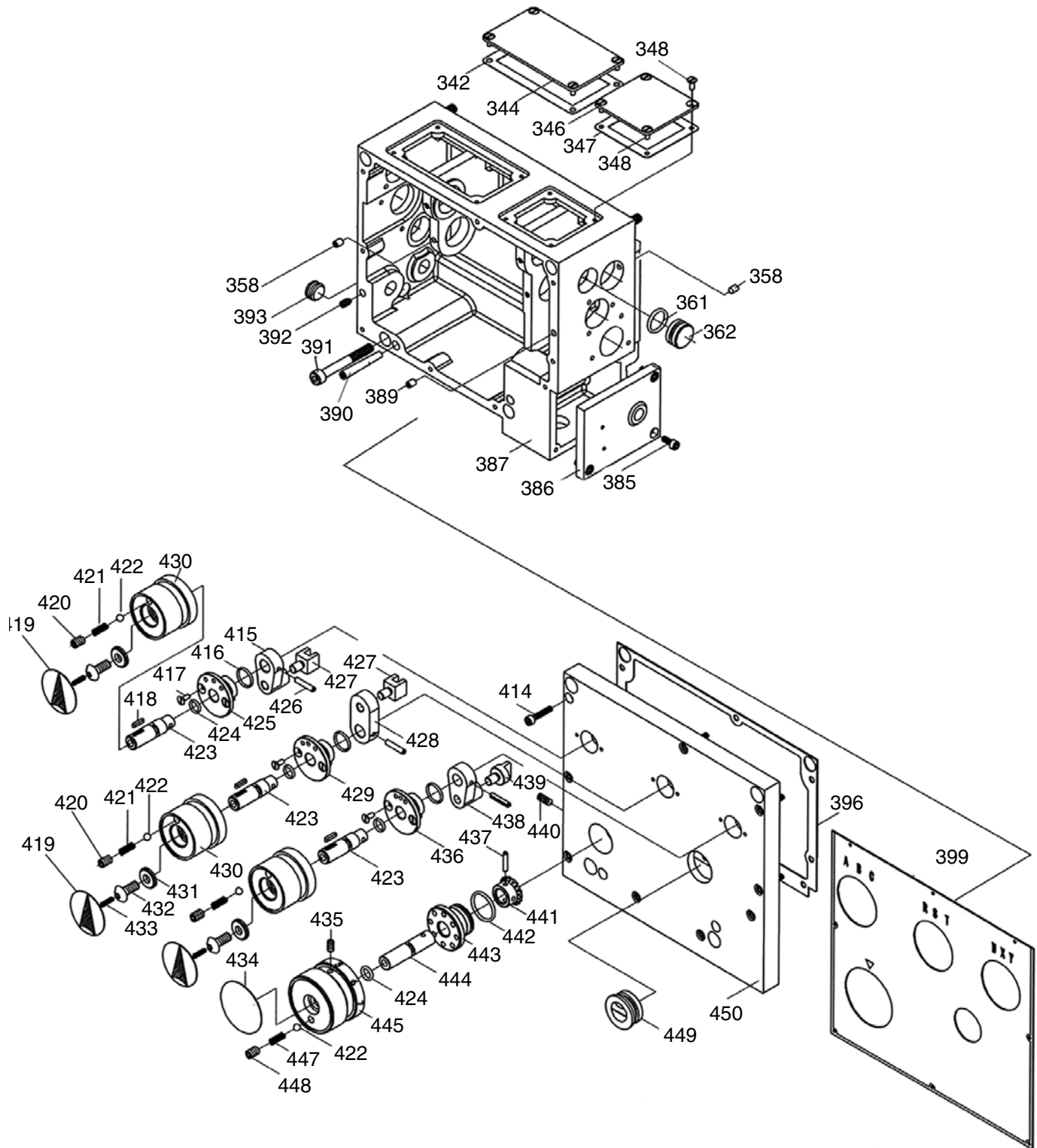
# Quick Change Gearbox Drive Parts List

REF	PART #	DESCRIPTION
301	P07090301	SHAFT
302	P07090302	OIL SEAL
303	P07090303	BUSHING
304	P07090304	CAP SCREW M6-1 X 25
305	P07090305	SHIFT FORK A
306	P07090306	SHIFT FORK B
307	P07090307	BUSHING HOUSING
308	P07090308	SHIFT FORK C
309	P07090309	SHIFT FORK D
310	P07090310	GASKET
311	P07090311	O-RING 9.8 X 2.4 P10A
312	P07090312	SPACER WASHER
313	P07090313	SET SCREW M5-.8 X 12
314	P07090314	EXT RETAINING RING 16MM
315	P07090315	COMBO GEAR 19T-20T
316	P07090316	BUSHING
317	P07090317	BUSHING
318	P07090318	SHAFT
319	P07090319	SPLINED SHAFT
320	P07090320	O-RING 9.8 X 2.4 P10A
321	P07090321	GEAR 22T
322	P07090322	GEAR 19T
323	P07090323	TAP-IN BALL OILER 6MM
324	P07090324	GEAR 20T
325	P07090325	SET SCREW M5-.8 X 8
326	P07090326	GEAR 24T
327	P07090327	GEAR 23T
328	P07090328	GEAR 27T
329	P07090329	GEAR 24T
330	P07090330	GEAR 28T
331	P07090331	GEAR 26T
332	P07090332	GEAR 38T
333	P07090333	BUSHING
334	P07090334	BUSHING
335	P07090335	CAP SCREW M5-.8 X 12
336	P07090336	OIL PLUG 3/8 NPT
337	P07090337	END COVER
338	P07090338	GASKET
339	P07090339	ROLL PIN 5 X 30
340	P07090340	COMBO GEAR 19T-50T
341	P07090341	BUSHING
343	P07090343	COMBO GEAR 38T-16T
345	P07090345	BUSHING
349	P07090349	SHAFT
350	P07090350	COMBO GEAR 23T-19T
351	P07090351	BUSHING
352	P07090352	ROLL PIN 5 X 28
353	P07090353	GEAR 35T
354AV2	P07090354AV2	FEED CLUTCH SHAFT ASSEMBLY V2.11.10

REF	PART #	DESCRIPTION
354V2	P07090354V2	FEED CLUTCH SHAFT V2.11.10
356V2	P07090356V2	THRUST BEARING 51103 V2.11.10
357V2	P07090357V2	END COVER V2.11.10
360V2	P07090360V2	GEAR 26T V2.11.10
363	P07090363	BUSHING
364	P07090364	GEAR 35T
365	P07090365	SPLINE SHAFT
366	P07090366	EXT RETAINING RING 16MM
367	P07090367	GEAR 26T
368	P07090368	BUSHING
369	P07090369	ROLL PIN 3 X 16
370	P07090370	SLEEVE
371	P07090371	GASKET
372	P07090372	END COVER
373	P07090373	CAP SCREW M4-.7 X 12
374	P07090374	GEAR 36T
375	P07090375	ROLL PIN 4 X 30
376	P07090376	ROLL PIN 4 X 18
377	P07090377	SHAFT
378	P07090378	SPLINED SHAFT
379	P07090379	OIL SEAL
380	P07090380	CAP SCREW M5-.8 X 12
381	P07090381	SUPPORT BOSS
382	P07090382	GASKET
383	P07090383	BUSHING
384	P07090384	SET SCREW M6-1 X 14
388	P07090388	ROLL PIN 5 X 28
395	P07090395	O-RING 19.8 X 2.4 P20
397	P07090397	BUSHING
398	P07090398	GEAR 22T
400	P07090400	GEAR 22T
401	P07090401	GEAR 22T
402	P07090402	GEAR 33T
403	P07090403	GEAR 22T
404	P07090404	O-RING 8.8 X 1.9 P9
405	P07090405	O-RING 17.8 X 2.4 P18
406	P07090406	SHAFT
407	P07090407	O-RING 25.2 X 3.5 P25.5
408	P07090408	BUSHING
409	P07090409	SET SCREW M5-.8 X 10
410	P07090410	BALL HEAD PIN
411	P07090411	CAM
412	P07090412	BEVEL GEAR 18T
413	P07090413	ROLL PIN 4 X 12
451	P07090451	SPANNER NUT M16-1.5
452	P07090452	CAP SCREW M5-.8 X 16
453	P07090453	BUSHING SF-1F 12090
454	P07090454	KEY 5 X 5 X 10
455	P07090455	BUSHING SF-1 1710



# Quick Change Gearbox Shift





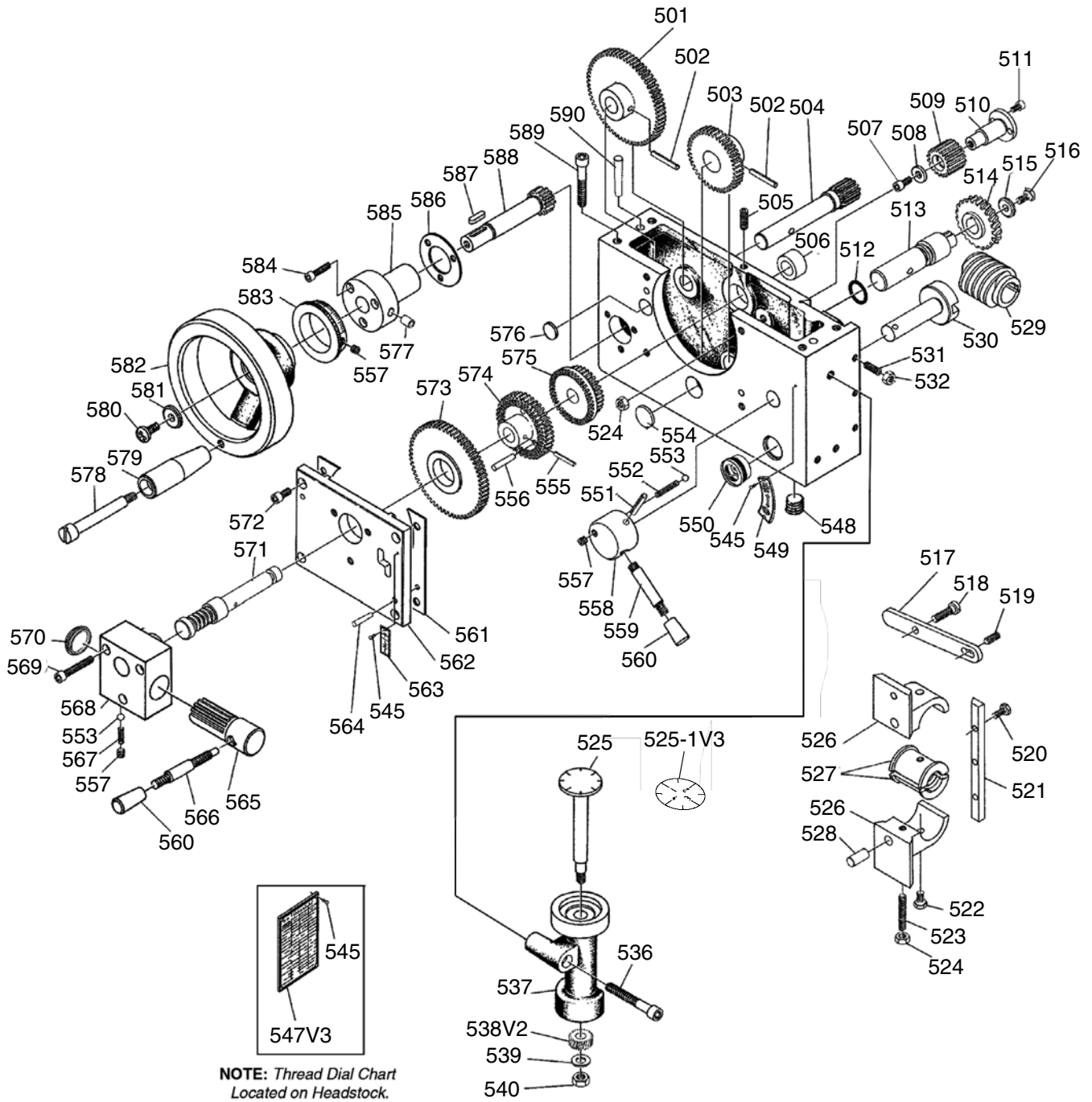
# Quick Change Gearbox Shift Parts List

REF	PART #	DESCRIPTION
342	P07090342	GASKET
344	P07090344	LEFT COVER
346	P07090346	RIGHT COVER
347	P07090347	GASKET
348	P07090348	FLAT HD SCR M4-.7 X 10
358	P07090358	SET SCREW M6-1 X 10
361	P07090361	O-RING 23.7 X 2.5
362	P07090362	PLUG
385	P07090385	CAP SCREW M5-.8 X 12
386	P07090386	CASE COVER
387	P07090387	GEARBOX CASE
388	P07090388	ROLL PIN 5 X 28
389	P07090389	SET SCREW M6-1 X 14
390	P07090390	TAPER PIN 6 X 50
391	P07090391	CAP SCREW M8-1.25 X 65
392	P07090392	SET SCREW M5-.8 X 12
393	P07090393	PLUG 1/2 NPT
396	P07090396	GASKET
399	P07090399	GEARBOX FACE PLATE
414	P07090414	CAP SCREW M5-.8 X 25
415	P07090415	ARM
416	P07090416	O-RING 17.5 X 1.5 S18
417	P07090417	FLAT HD SCR M4-.7 X 10
418	P07090418	KEY 3 X 3 X 14
419	P07090419	ARROW PLATE
420	P07090420	SET SCREW M8-1.25 X 12
421	P07090421	COMPRESSION SPRING
422	P07090422	STEEL BALL 1/4

REF	PART #	DESCRIPTION
423	P07090423	SHIFT SHAFT
424	P07090424	O-RING 9.8 X 2.4 P10A
425	P07090425	SHAFT SLEEVE
426	P07090426	ROLL PIN 4 X 24
427	P07090427	SHIFT FORK
428	P07090428	ARM
429	P07090429	SHAFT SLEEVE
430	P07090430	DIAL HUB
431	P07090431	FLAT WASHER 8MM
432	P07090432	DOME HD SCR M8-1.25 x 20 BLK
433	P07090433	SET SCREW M4-.7 X 20
434	P07090434	COVER PLATE
435	P07090435	SET SCREW M6-1 X 14
436	P07090436	SHAFT SLEEVE
437	P07090437	ROLL PIN 4 X 20
438	P07090438	ARM
439	P07090439	SHIFT CLAW
440	P07090440	SET SCREW M6-1 X 16
441	P07090441	BEVEL GEAR 18T
442	P07090442	O-RING 19.8 X 2.4 P20
443	P07090443	SHAFT SLEEVE
444	P07090444	SHIFT SHAFT
445	P07090445	DIAL HUB
447	P07090447	COMPRESSION SPRING
448	P07090448	SET SCREW M8-1.25 X 12
449	P07090449	OIL SIGHT GLASS
450	P07090450	GEARBOX FACE CASTING



# Apron



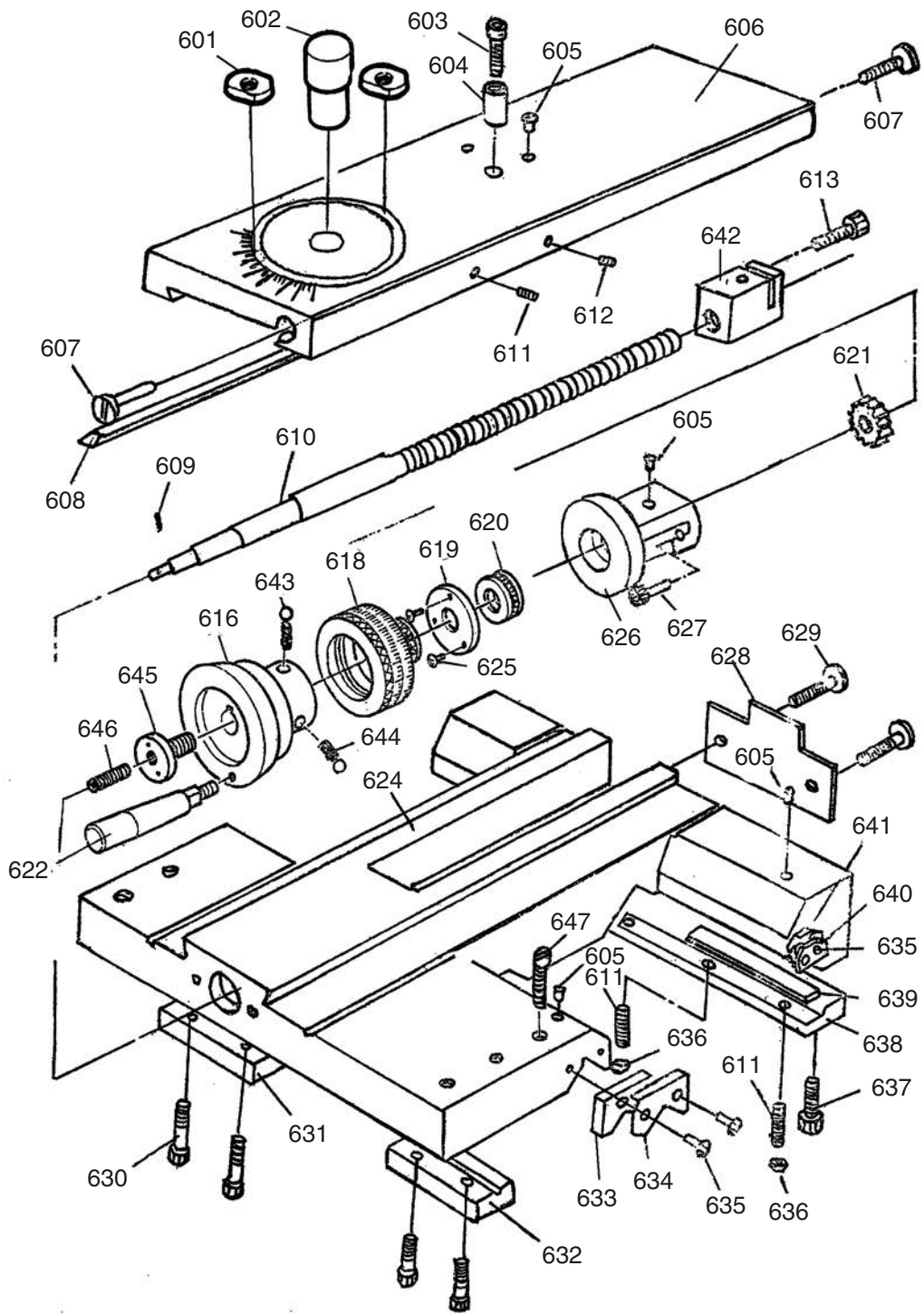
# Apron Parts List

REF	PART #	DESCRIPTION
501	P07090501	GEAR 60T
502	P07090502	ROLL PIN 5 X 30
503	P07090503	GEAR 40T
504	P07090504	PINION 13T
505	P07090505	SET SCREW M6-1 X 16
506	P07090506	BUSHING
507	P07090507	CAP SCREW M6-1 X 12
508	P07090508	FLAT WASHER 6MM
509	P07090509	GEAR 18T
510	P07090510	IDLER SHAFT
511	P07090511	CAP SCREW M5-.8 X 12
512	P07090512	O-RING 20 X 2.4
513	P07090513	SHAFT
514	P07090514	WORM GEAR
515	P07090515	FLAT WASHER 6MM
516	P07090516	CAP SCREW M6-1 X 12
517	P07090517	INTERLOCK LEVER
518	P07090518	CAP SCREW M6-1 X 12
519	P07090519	SET SCREW M6-1 X 12
520	P07090520	HEX BOLT M5-.8 X 20
521	P07090521	GIB
522	P07090522	HEX BOLT M6-1 X 10
523	P07090523	SET SCREW M6-1 X 35
524	P07090524	HEX NUT M6-1
525	P07090525	DIAL INDICATOR
525-1V3	P07090525-1V3	THREAD DIAL LABEL V3.06.17
526	P07090526	HALF NUT RETAINER
527	P07090527	HALF NUT ASSEMBLY
528	P07090528	DOWEL PIN 8 X 16
529	P07090529	WORM
530	P07090530	CAM SHAFT
531	P07090531	SET SCREW M5-.8 X 16
532	P07090532	HEX NUT M5-.8
536	P07090536	CAP SCREW M8-1.25 X 50
537	P07090537	THREAD DIAL BODY
538V2	P07090538V2	HELICAL GEAR 32T V2.06.17
539	P07090539	FLAT WASHER 8MM
540	P07090540	HEX NUT M8-1.25
545	P07090545	STEEL FLUTED RIVET 3 X 5
547V3	P07090547V3	THREAD DIAL CHART V3.06.17
548	P07090548	DRAIN PLUG 1/8 NPT
549	P07090549	HALF NUT INDICATOR PLATE

REF	PART #	DESCRIPTION
550	P07090550	OIL SIGHT GLASS
551	P07090551	ROLL PIN 5 X 35
552	P07090552	COMPRESSION SPRING
553	P07090553	STEEL BALL 3/16
554	P07090554	PLUG
555	P07090555	ROLL PIN 3 X 25
556	P07090556	ROLL PIN 5 X 25
557	P07090557	SET SCREW M6-1 X 6
558	P07090558	LEVER HUB
559	P07090559	LEVER
560	P07090560	KNOB M8-1.25
561	P07090561	SPACER
562	P07090562	FRONT COVER
563	P07090563	FEED INDICATOR PLATE
564	P07090564	TAPER PIN 5 X 20
565	P07090565	CAM SHAFT
566	P07090566	CHANGE LEVER
567	P07090567	COMPRESSION SPRING
568	P07090568	BRACKET
569	P07090569	CAP SCREW M6-1 X 35
570	P07090570	PLUG
571	P07090571	TOOTHED SHIFT SHAFT
572	P07090572	CAP SCREW M6-1 X 16
573	P07090573	CLUTCH GEAR 63T
574	P07090574	CLUTCH GEAR 40T
575	P07090575	COMBO CLUTCH GEAR 30T
576	P07090576	PLUG
577	P07090577	TAP-IN BALL OILER 8MM
578	P07090578	HANDLE SHOULDER SCREW
579	P07090579	HANDLE
580	P07090580	FLAT HD SCR M6-1 X 16
581	P07090581	FLAT WASHER 6MM
582	P07090582	HANDWHEEL
583	P07090583	CALIBRATED RING
584	P07090584	CAP SCREW M5-.8 X 25
585	P07090585	SUPPORT HUB
586	P07090586	SPACER
587	P07090587	KEY 5 X 5 X 20
588	P07090588	GEARED SHAFT 14T
589	P07090589	CAP SCREW M8-1.25 X 30
590	P07090590	TAPER PIN 8 X 40



# Cross Slide



# Cross Slide Parts List

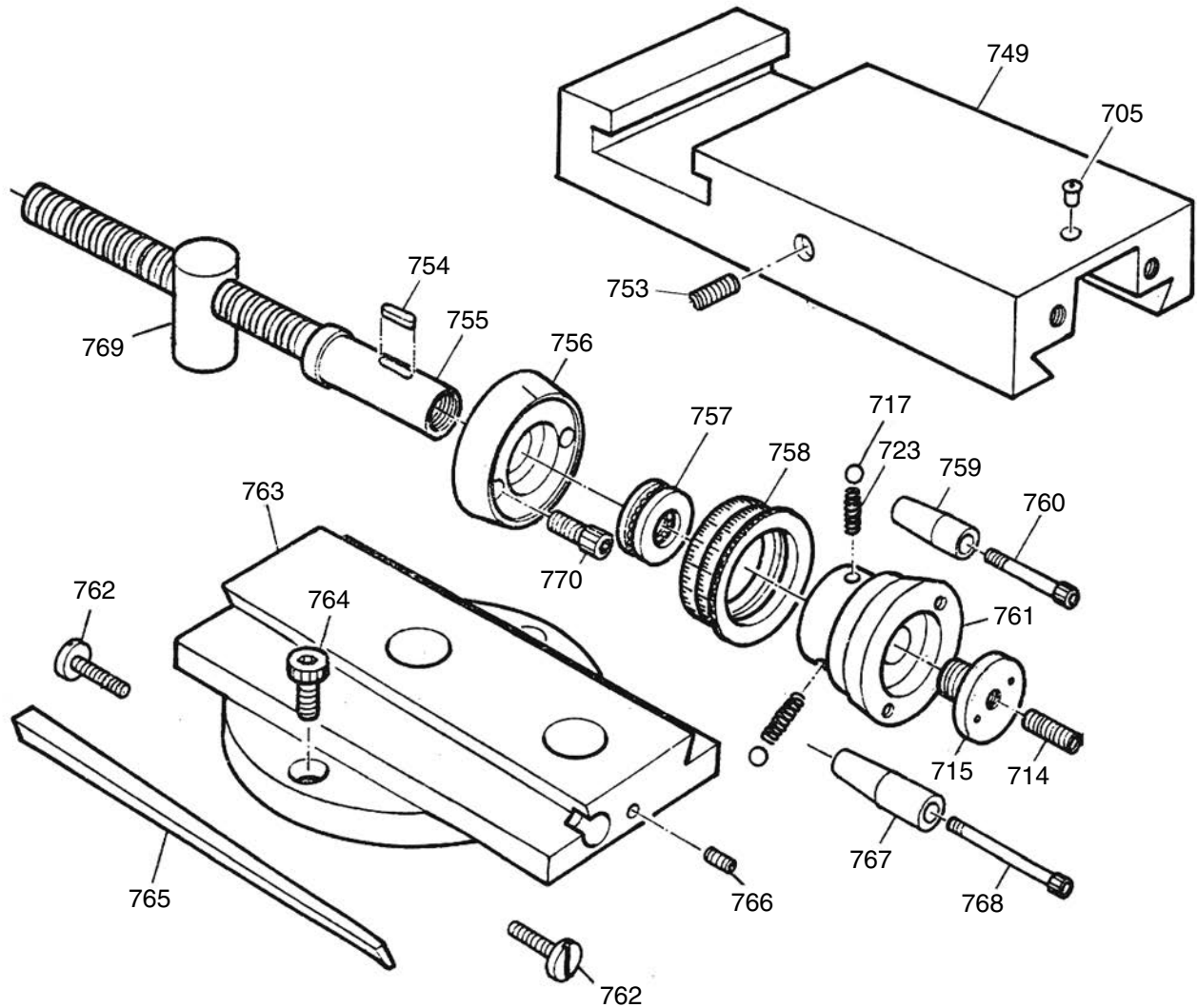
REF	PART #	DESCRIPTION
601	P07090601	T-NUT
602	P07090602	PIVOT PIN
603	P07090603	CAP SCREW M6-1 X 16
604	P07090604	BUSHING
605	P07090605	TAP-IN BALL OILER 8MM
606	P07090606	CROSS SLIDE
607	P07090607	GIB SCREW
608	P07090608	GIB
609	P07090609	ROLL PIN 3 X 16
610	P07090610	CROSS-SLIDE LEADSCREW
611	P07090611	SET SCREW M6-1 X 25
612	P07090612	SET SCREW M8-1.25 X 10
613	P07090613	CAP SCREW M6-1 X 16
616	P07090616	HANDWHEEL HUB
618	P07090618	CALIBRATED RING
619	P07090619	BACKING PLATE
620	P07090620	THRUST BEARING 8102
621	P07090621	GEAR 19T
622	P07090622	HANDLE
624	P07090624	SADDLE CASTING
625	P07090625	PHLP HD SCR M5-.8 X 10
626	P07090626	SUPPORT HUB

REF	PART #	DESCRIPTION
627	P07090627	CAP SCREW M6-1 X 25
628	P07090628	DUST PLATE
629	P07090629	CAP SCREW M8-1.25 X 12
630	P07090630	CAP SCREW M8-1.25 X 20
631	P07090631	LEFT GIB SLIDE
632	P07090632	RIGHT GIB SLIDE
633	P07090633	WIPER
634	P07090634	WIPER SUPPORT PLATE
635	P07090635	PHLP HD SCR M4-.7 X 12
636	P07090636	HEX NUT M6-1
637	P07090637	CAP SCREW M8-1.25 X 25
638	P07090638	GIB SUPPORT
639	P07090639	GIB STRIP
640	P07090640	WIPER SUPPORT PLATE
641	P07090641	WIPER
642	P07090642	CROSS-SLIDE LEADSCREW NUT
643	P07090643	STEEL BALL 6MM
644	P07090644	COMPRESSION SPRING
645	P07090645	INNER HUB
646	P07090646	SET SCREW M6-1 X 25
647	P07090647	CAP SCREW M8-1.25 X 55





# Compound Slide

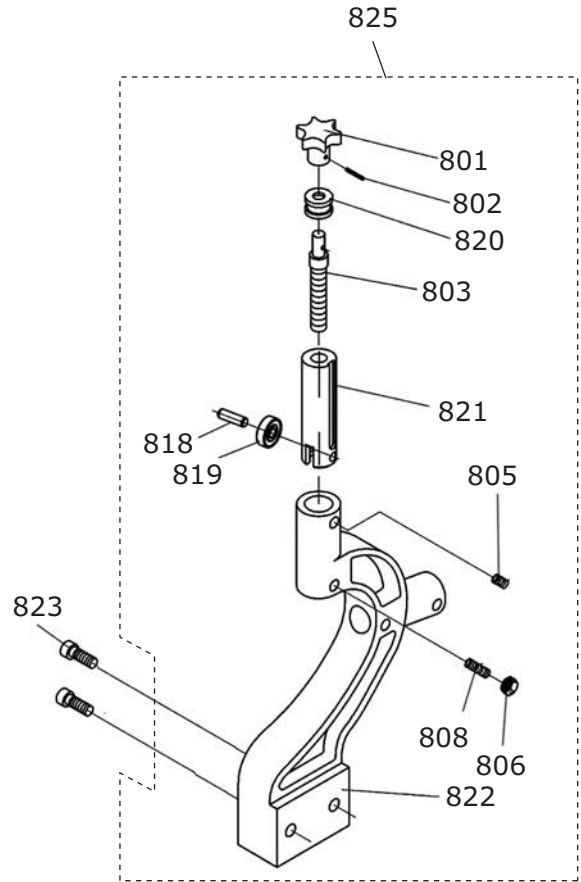
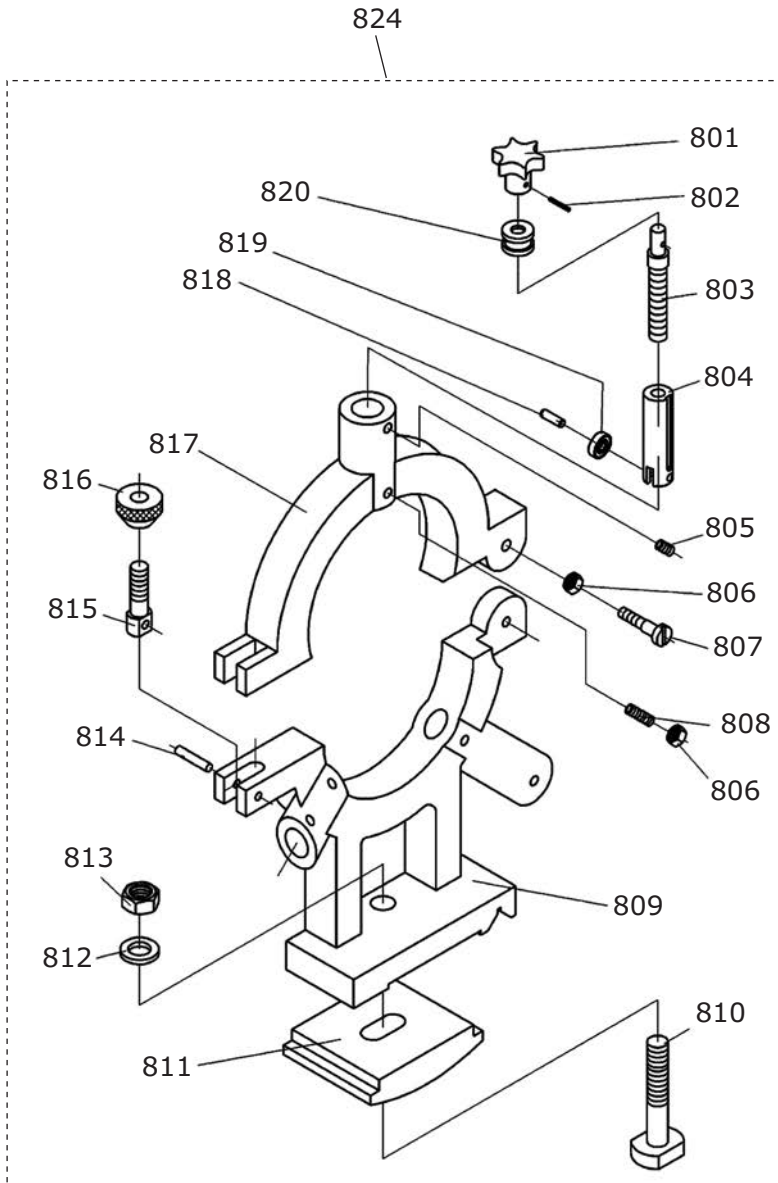


REF	PART #	DESCRIPTION
705	P07090705	TAP-IN BALL OILER 6MM
714	P07090714	SET SCREW M6-1 X 25
715	P07090715	INNER HUB
717	P07090717	STEEL BALL 6MM
723	P07090723	COMPRESSION SPRING
749	P07090749	COMPOUND SLIDE
753	P07090753	SET SCREW M8-1.25 X 20
754	P07090754	KEY 4 X 4 X 14
755	P07090755	COMPOUND LEADSCREW
756	P07090756	BEARING HOUSING
757	P07090757	THRUST BEARING 8103
758	P07090758	CALIBRATED RING

REF	PART #	DESCRIPTION
759	P07090759	HANDLE
760	P07090760	HANDLE SHOULDER SCREW
761	P07090761	HANDWHEEL HUB
762	P07090762	GIB SCREW
763	P07090763	SWIVEL SLIDE
764	P07090764	CAP SCREW M8-1.25 X 16
765	P07090765	GIB
766	P07090766	SET SCREW M6-1 X 16
767	P07090767	HANDLE
768	P07090768	HANDLE SHOULDER SCREW
769	P07090769	COMPOUND LEADSCREW NUT
770	P07090769	CAP SCREW M6-1 X 20



# Rests

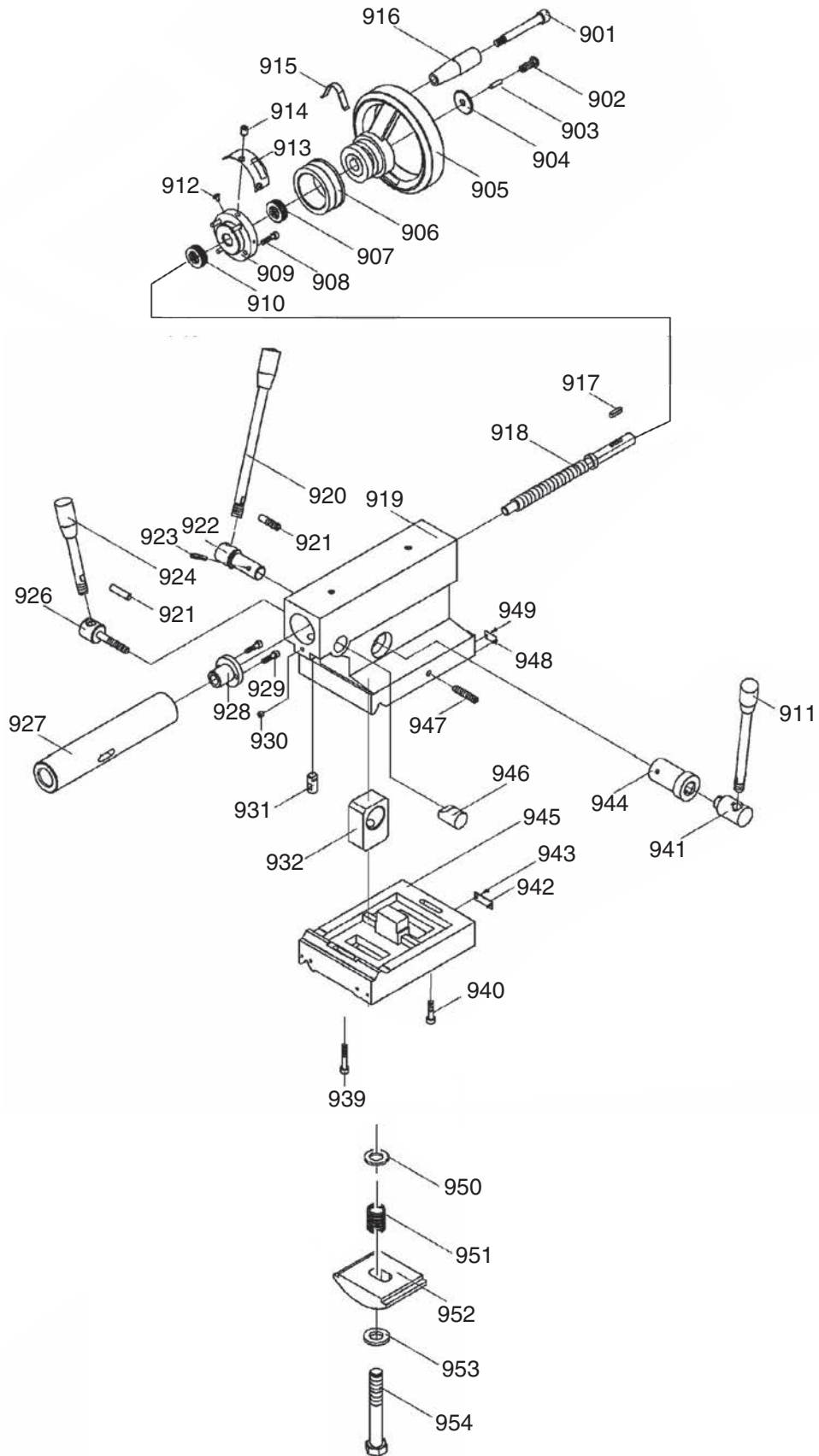


REF	PART #	DESCRIPTION
801	P07090801	PINNED KNOB
802	P07090802	ROLL PIN 3 X 18
803	P07090803	JACK SCREW
804	P07090804	FINGER SLIDE
805	P07090805	SET SCREW M6-1 X 6
806	P07090806	HEX NUT M6-1
807	P07090807	SLOTTED SCREW M6-1 X 30
808	P07090808	SET SCREW M6-1 X 16 DOG-PT
809	P07090809	LOWER STEADY REST CASTING
810	P07090810	T-BOLT M12-1.75 X 65
811	P07090811	CLAMP BLOCK
812	P07090812	FLAT WASHER 12MM
813	P07090813	HEX NUT M12-1.75

REF	PART #	DESCRIPTION
814	P07090814	DOWEL PIN 5 X 24
815	P07090815	PIVOT STUD
816	P07090816	KNURLED THUMB KNOB M10-1.5
817	P07090817	UPPER STEADY REST CASTING
818	P07090818	DOWEL PIN 5 X 16
819	P07090819	BALL BEARING 625ZZ
820	P07090820	COLLAR
821	P07090821	FINGER SLIDE
822	P07090822	FOLLOW REST CASTING
823	P07090823	CAP SCREW M8-1.25 X 45
824	P07090824	STEADY REST ASSEMBLY
825	P07090825	FOLLOW REST ASSEMBLY



# Tailstock



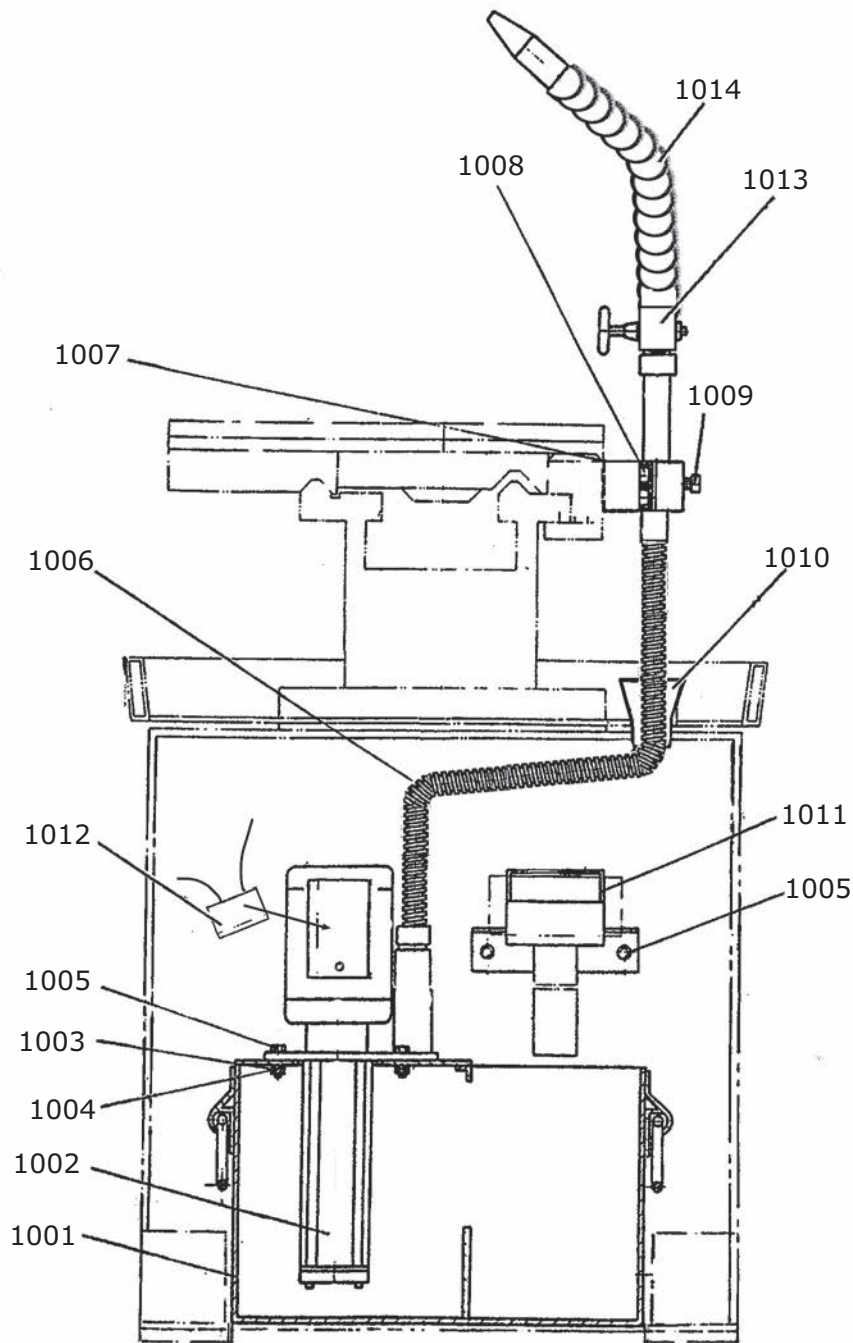
# Tailstock Parts List

REF	PART #	DESCRIPTION
901	P07090901	HANDLE SHOULDER SCREW
902	P07090902	DUAL THREAD CAP SCREW
903	P07090903	SET SCREW M5-.8 X 20
904	P07090904	FENDER WASHER 8MM
905	P07090905	HANDWHEEL
906	P07090906	INDEX RING
907	P07090907	THRUST BEARING 8102
908	P07090908	CAP SCREW M5-.8 X 20
909	P07090909	FLANGE HUB
910	P07090910	THRUST BEARING 8102
911	P07090911	LEVER
912	P07090912	FLAT HD SCR M4-.7 X 6
913	P07090913	CALIBRATED PLATE
914	P07090914	TAP-IN BALL OILER 6MM
915	P07090915	FLAT SPRING
916	P07090916	HANDLE
917	P07090917	KEY 5 X 5 X 20
918	P07090918	TAILSTOCK LEADSCREW
919	P07090919	TAILSTOCK CASTING
920	P07090920	TAILSTOCK LOCK LEVER
921	P07090921	STOP PIN
922	P07090922	LEVER HUB
923	P07090923	ROLL PIN 5 X 30
924	P07090924	QUILL LOCK LEVER

REF	PART #	DESCRIPTION
926	P07090926	HUB LOCK
927	P07090927	QUILL MT#3
928	P07090928	COLLAR
929	P07090929	CAP SCREW M5-.8 X 20
930	P07090930	SET SCREW M6-1 X 6
931	P07090931	GUIDE
932	P07090932	BLOCK
939	P07090939	CAP SCREW M6-1 X 35
940	P07090940	CAP SCREW M6-1 X 25
941	P07090941	DRIVE HUB
942	P07090942	SCALE PLATE
943	P07090943	RIVET 2 X 5
944	P07090944	SUPPORT COLLAR
945	P07090945	TAILSTOCK BASE
946	P07090946	LOCK BLOCK
947	P07090947	SET SCREW M8-1.25 X 40
948	P07090948	SCALE PLATE
949	P07090949	RIVET 2 X 5
950	P07090950	FLAT WASHER 16MM
951	P07090951	COMPRESSION SPRING
952	P07090952	BLOCK
953	P07090953	FLAT WASHER 16MM
954	P07090954	HEX BOLT M16-2 X 120



# Pump



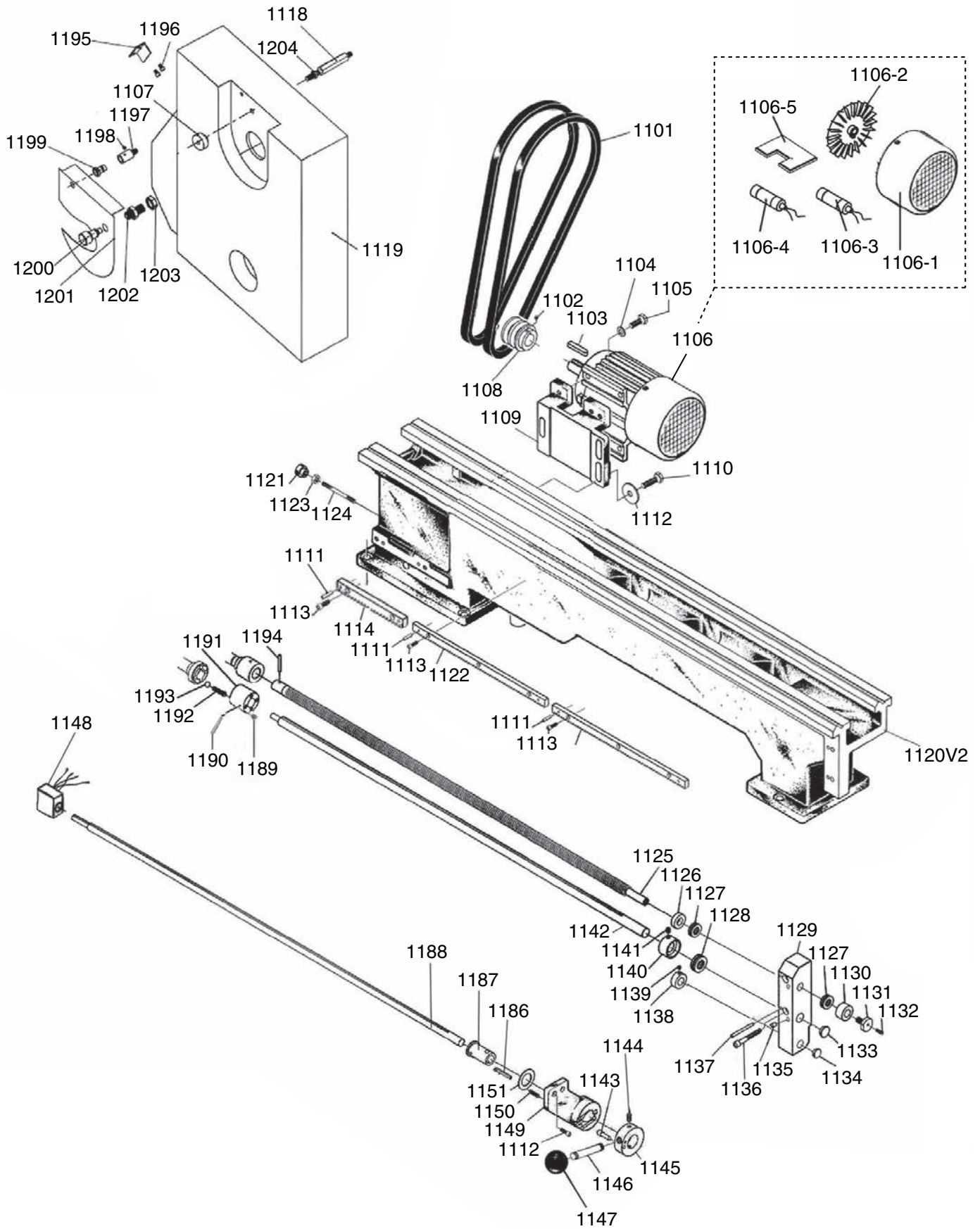
REF	PART #	DESCRIPTION
1001	P07091001	COOLANT TANK
1002	P07091002	COOLANT PUMP 0.8HP 110V/220V 1-PH
1003	P07091003	HEX NUT M6-1
1004	P07091004	LOCK WASHER 6MM
1005	P07091005	HEX BOLT M6-1 X 15
1006	P07091006	COOLANT PIPE ASSEMBLY
1007	P07091007	MOUNTING BASE

REF	PART #	DESCRIPTION
1008	P07091008	CAP SCREW M5-.8 X 25
1009	P07091009	CAP SCREW M5-.8 X 16
1010	P07091010	RUBBER BUSHING
1011	P07091011	RETURN SPOUT
1012	P07091012	SQUARE CAPACITOR 2M/450V
1013	P07091013	CONTROL VALVE
1014	P07091014	COOLANT TUBE W/NOZZLE





# Motor & Feed Rod



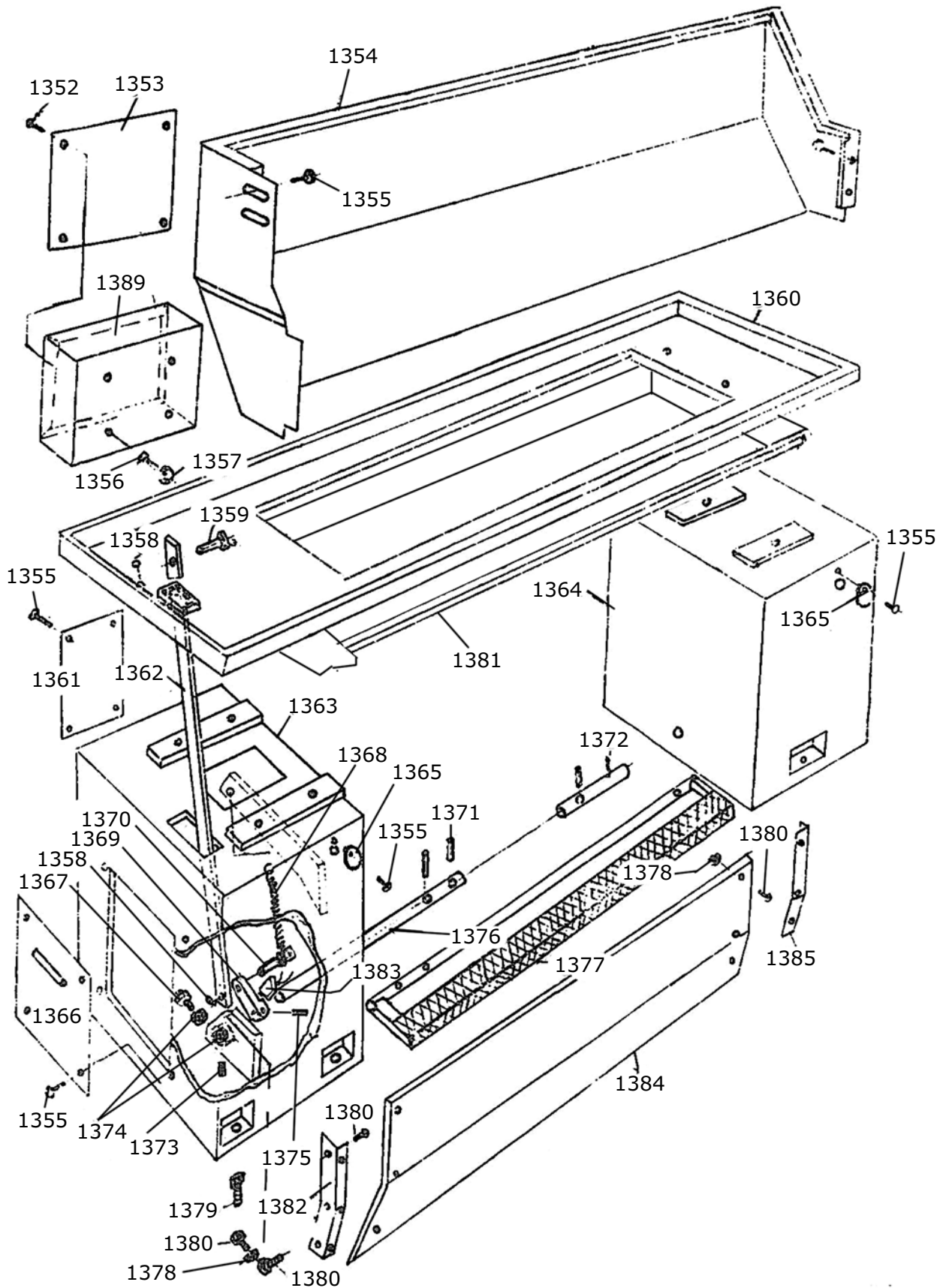
# Motor and Feed Rod Parts List

REF	PART #	DESCRIPTION
1101	P07091101	GATES TRUE-POWER V13 X 890
1102	P07091102	SET SCREW M6-1 X 12
1103	P07091103	KEY 8 x 8 X 40
1104	P07091104	LOCK WASHER 8MM
1105	P07091105	HEX BOLT M8-1.25 X 25
1106	P07091106	MOTOR 2HP 110V/220V 1-PH
1106-1	P07091106-1	FAN COVER
1106-2	P07091106-2	FAN
1106-3	P07091106-3	S CAPACITOR 150M 250V 1-3/8 X 2-3/4
1106-4	P07091106-4	R CAPACITOR 20M 400V 1-5/8 X 2-3/4
1106-5	P07091106-5	ELECTRICAL BOX COVER
1107	P07091107	KNURLED KNOB M8-1.25
1108	P07091108	MOTOR PULLEY
1109	P07091109	MOTOR MOUNT
1110	P07091110	HEX BOLT M10-1.5 X 30
1111	P07091111	ROLL PIN 6 X 25
1112	P07091112	FLAT WASHER 10MM
1113	P07091113	CAP SCREW M6-1 X 25
1114	P07091114	GAP RACK
1118	P07091118	HEX STUD M8-1.25
1119	P07091119	GEAR COVER
1120V2	P07091120V2	LATHE BED V2.01.21
1121	P07091121	KNURLED KNOB M10-1.5
1122	P07091122	RACK
1123	P07091123	HEX NUT M10-1.5
1124	P07091124	STUD M10-1.5
1125	P07091125	LONGITUDINAL LEADSCREW
1126	P07091126	SLEEVE
1127	P07091127	THRUST BEARING 8102
1128	P07091128	THRUST BEARING 8104
1129	P07091129	HOUSING
1130	P07091130	BEARING COVER
1131	P07091131	SHOULDER FLANGE SCREW
1132	P07091132	SET SCREW M6-1 X 20
1133	P07091133	END PLUG
1134	P07091134	END PLUG

REF	PART #	DESCRIPTION
1135	P07091135	TAP-IN BALL OILER 6MM
1136	P07091136	CAP SCREW M8-1.25 X 60
1137	P07091137	TAPER PIN 5 X 60
1138	P07091138	LOCK COLLAR
1139	P07091139	SET SCREW M6-1 X 8
1140	P07091140	LOCKING BEARING COVER
1141	P07091141	SET SCREW M8-1.25 X 10
1142	P07091142	FEED ROD
1143	P07091143	INDEX LUG PIN
1144	P07091144	SET SCREW M8-1.25 X 16
1145	P07091145	RETAINER COLLAR
1146	P07091146	SPINDLE ON/OFF LEVER
1147	P07091147	PLASTIC BALL KNOB M12-1.75
1148	P07091148	SPINDLE ON/OFF SWITCH ASSEMBLY
1149	P07091149	HOUSING
1150	P07091150	COMPRESSION SPRING
1151	P07091151	THRUST WASHER
1186	P07091186	KEY 4 X 4 X 40
1187	P07091187	FLANGED SLEEVE
1188	P07091188	CONTROL ROD
1189	P07091189	CONE SET SCREW M4-.7 X 4.5
1190	P07091190	FLAT HD SCR M4-.7 X 6
1191	P07091191	CLUTCH ASSEMBLY
1192	P07091192	COMPRESSION SPRING
1193	P07091193	STEEL BALL 6MM
1194	P07091194	SHEAR PIN
1195	P07091195	SHUT-OFF SUPPORT
1196	P07091196	PHLP HD SCR M5-.8 X 8
1197	P07091197	PIVOT SHAFT SOCKET
1198	P07091198	SET SCREW M5-.8 X 6
1199	P07091199	PIVOT SHAFT
1200	P07091200	KNURLED KNOB M8-1.25
1201	P07091201	SPIDER SAFETY GUARD
1202	P07091202	THREADED RECEIVER M16-2
1203	P07091203	HEX NUT M16-2
1204	P07091204	HEX NUT M8-1.25



# Cabinet and Brake



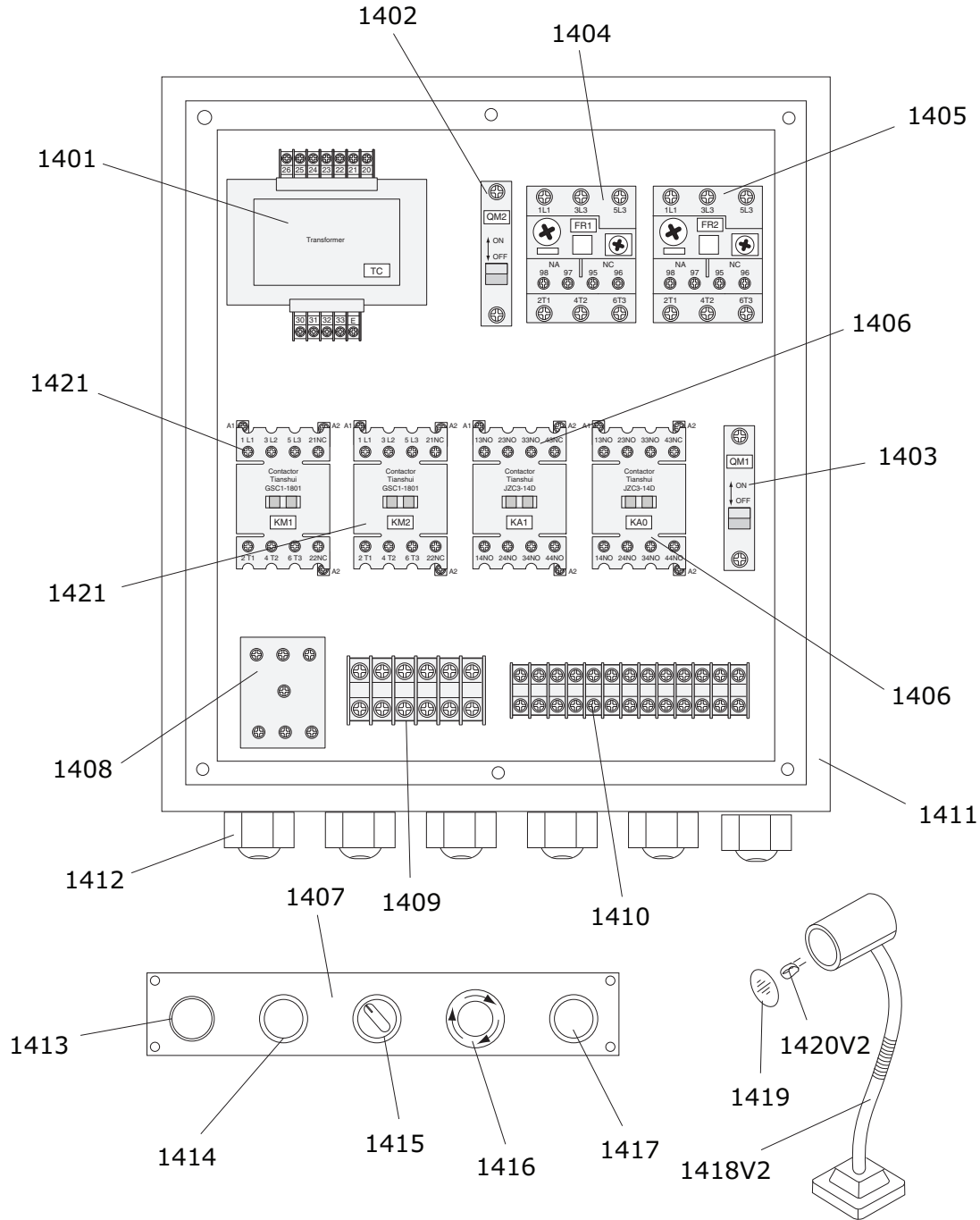
# Cabinet and Brake Parts List

REF	PART #	DESCRIPTION
1352	P07091352	PHLP HD SCR M5-.8 X 6
1353	P07091353	COVER
1354	P07091354	SPLASH GUARD
1355	P07091355	PHLP HD SCR M6-1 X 10
1356	P07091356	CAP SCREW M6-1 X 20
1357	P07091357	FLAT WASHER 6MM
1358	P07091358	COTTER PIN 2 X 12
1359	P07091359	CLEVIS PIN
1360	P07091360	BASE PAN
1361	P07091361	REAR ACCESS PLATE
1362	P07091362	BRAKE PULL ROD
1363	P07091363	LEFT BASE
1364	P07091364	RIGHT BASE
1365	P07091365	ROUND COVER
1366	P07091366	LEFT ACCESS PLATE
1367	P07091367	DOME SCREW
1368	P07091368	EXTENSION SPRING
1369	P07091369	PEDAL ARM

REF	PART #	DESCRIPTION
1370	P07091370	CLEVIS PIN
1371	P07091371	ROLL PIN 3 X 25
1372	P07091372	SHAFT
1373	P07091373	SET SCREW M8-1.25 X 6
1374	P07091374	HEX NUT M8-1.25
1375	P07091375	ROLL PIN 5 X 40
1376	P07091376	PEDAL SHAFT
1377	P07091377	BRAKE PEDAL
1378	P07091378	HEX NUT M6-1
1379	P07091379	CAP SCREW M12-1.75 X 50
1380	P07091380	CAP SCREW M6-1 X 10
1381	P07091381	CHIP DRAWER
1382	P07091382	LEFT CORNER PLATE
1383	P07091383	LIMIT SWITCH
1384	P07091384	FRONT PLATE
1385	P07091385	RIGHT CORNER PLATE
1389	P07091389	MAIN ELECTRICAL BOX



# Main Electrical Breakdown



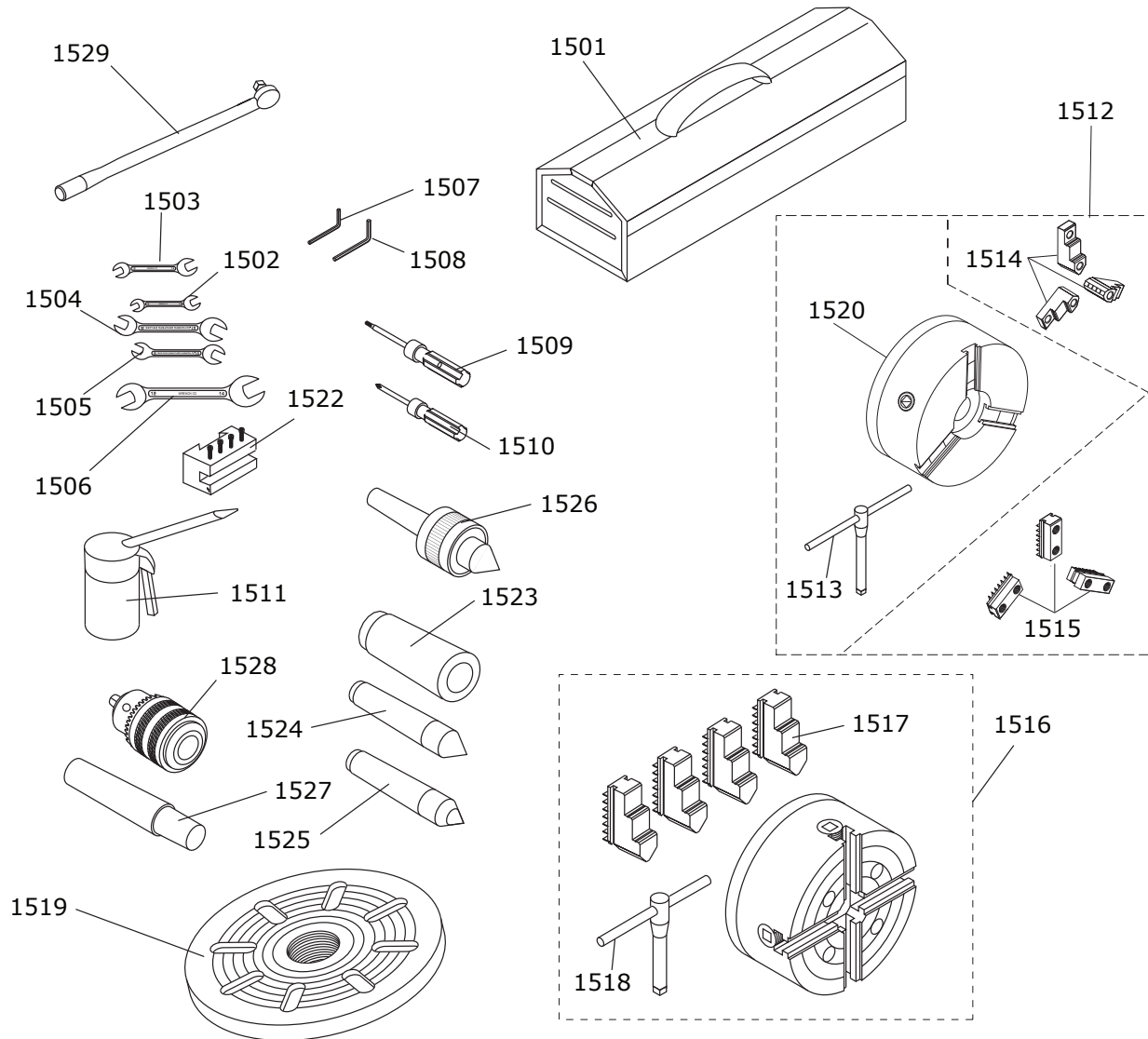
REF	PART #	DESCRIPTION
1401	P07091401	TRANSFORMER WUXI JBK5-100VATH
1402	P07091402	CIRCUIT BREAKER 3A TIANSHUI, DZ451-63
1403	P07091403	CIRCUIT BREAKER 5A TIANSHUI, DZ451-63
1404	P07091404	OL RELAY TIANSHUI JRS4-09/25D 9-13A
1405	P07091405	OL RELAY TIANSHUI JRS4-09/25D 0.4-0.63A
1406	P07091406	CONTACTOR TIAN JZC3-40D 110V
1407	P07091407	CONTROL PANEL PLATE
1408	P07091408	COPPER GROUND BLOCK
1409	P07091409	TERMINAL BAR 12 P
1410	P07091410	TERMINAL BAR 26 P
1411	P07091411	ELECTRICAL BOX ASSEMBLY

REF	PART #	DESCRIPTION
1412	P07091412	STRAIN RELIEF
1413	P07091413	INDICATOR LIGHT
1414	P07091414	POWER BUTTON
1415	P07091415	PUMP ON/OFF SWITCH
1416	P07091416	EMERGENCY STOP SWITCH
1417	P07091417	JOG BUTTON
1418V2	P07091418V2	LED WORK LAMP ASSY
1419	P07091419	LAMP LENS
1420V2	P07091420V2	LED BULB 24V MR16 (1W X 3) V3.05.15
1421	P07091421	CONTACTOR TIANSHUI GSC1-1801 110V





# Accessories

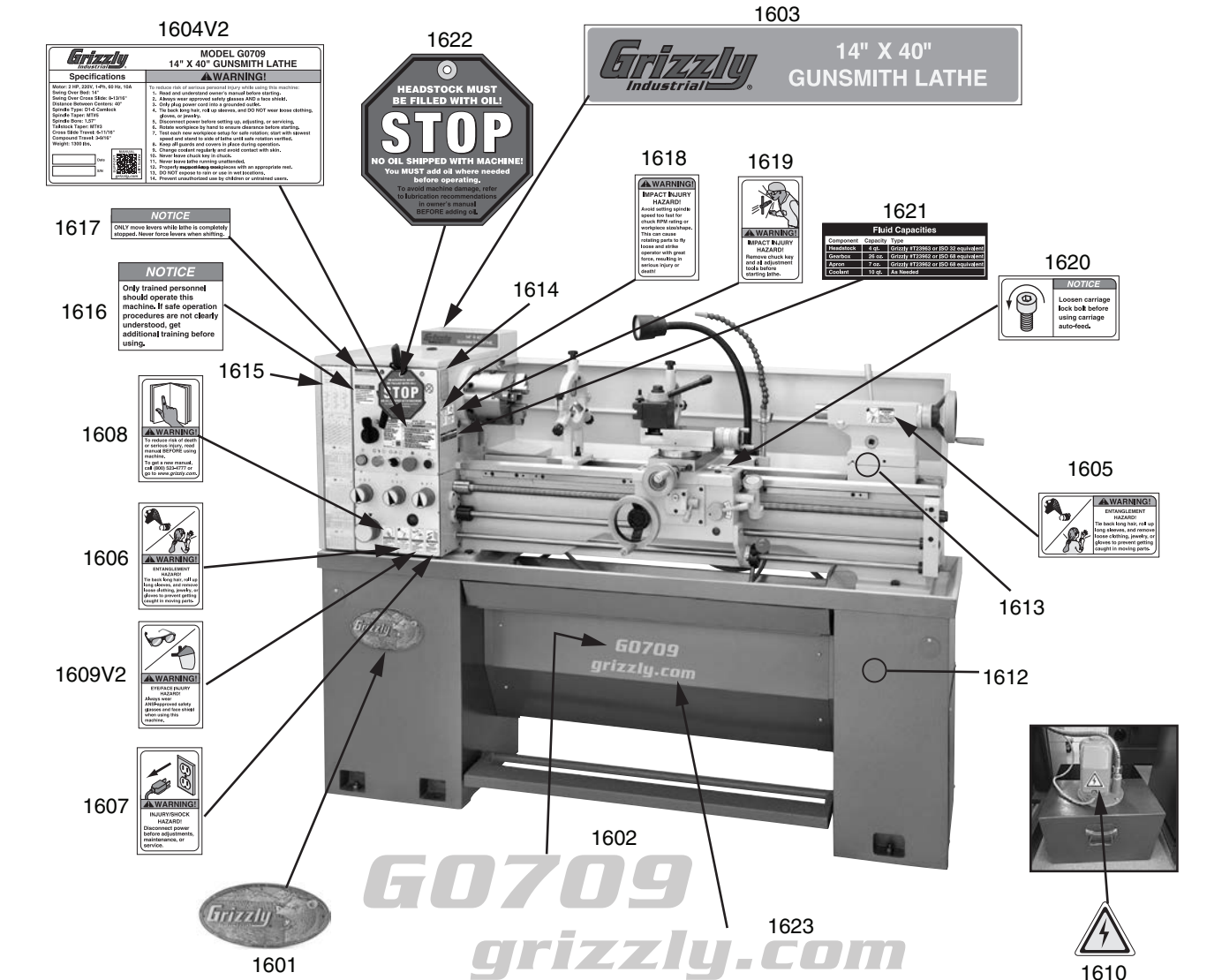


REF	PART #	DESCRIPTION
1501	P07091501	TOOL BOX
1502	P07091502	OPEN END WRENCH 9/11MM
1503	P07091503	COMBO WRENCH 12 X 14MM
1504	P07091504	COMBO WRENCH 13 X 16MM
1505	P07091505	COMBO WRENCH 17 X 19MM
1506	P07091506	COMBO WRENCH 24 X 27MM
1507	P07091507	HEX WRENCH 6MM
1508	P07091508	HEX WRENCH 8MM
1509	P07091509	PHLP HD SCREWDRIVER #2
1510	P07091510	SCREWDRIVER FLAT #2
1511	P07091511	OIL GUN
1512	P07091512	3-JAW CHUCK 6" D1-5 ASSEMBLY
1513	P07091513	3-JAW CHUCK WRENCH
1514	P07091514	3-JAW CHUCK TOP JAW SET

REF	PART #	DESCRIPTION
1515	P07091515	3-JAW CHUCK BOTTOM JAW SET
1516	P07091516	4-JAW CHUCK 8" D1-5
1517	P07091517	4-JAW CHUCK REVERSIBLE JAW
1518	P07091518	4-JAW CHUCK WRENCH
1519	P07091519	FACEPLATE 11" D1-5
1520	P07091520	3-JAW CHUCK 6" D1-5
1522	P07091522	TOOL HOLDER 200-SERIES
1523	P07091523	SPINDLE SLEEVE MT#5-MT#3
1524	P07091524	DEAD CENTER MT#3 SOLID
1525	P07091525	DEAD CENTER MT#3 CARBIDE-TIPPED
1526	P07091526	LIVE CENTER MT#3
1527	P07091527	DRILL CHUCK ARBOR MT#3/B16
1528	P07091528	DRILL CHUCK B16 1.5-13MM
1529	P07091529	TAILSTOCK LEVER 1/2 DRIVE



# Labels & Cosmetics

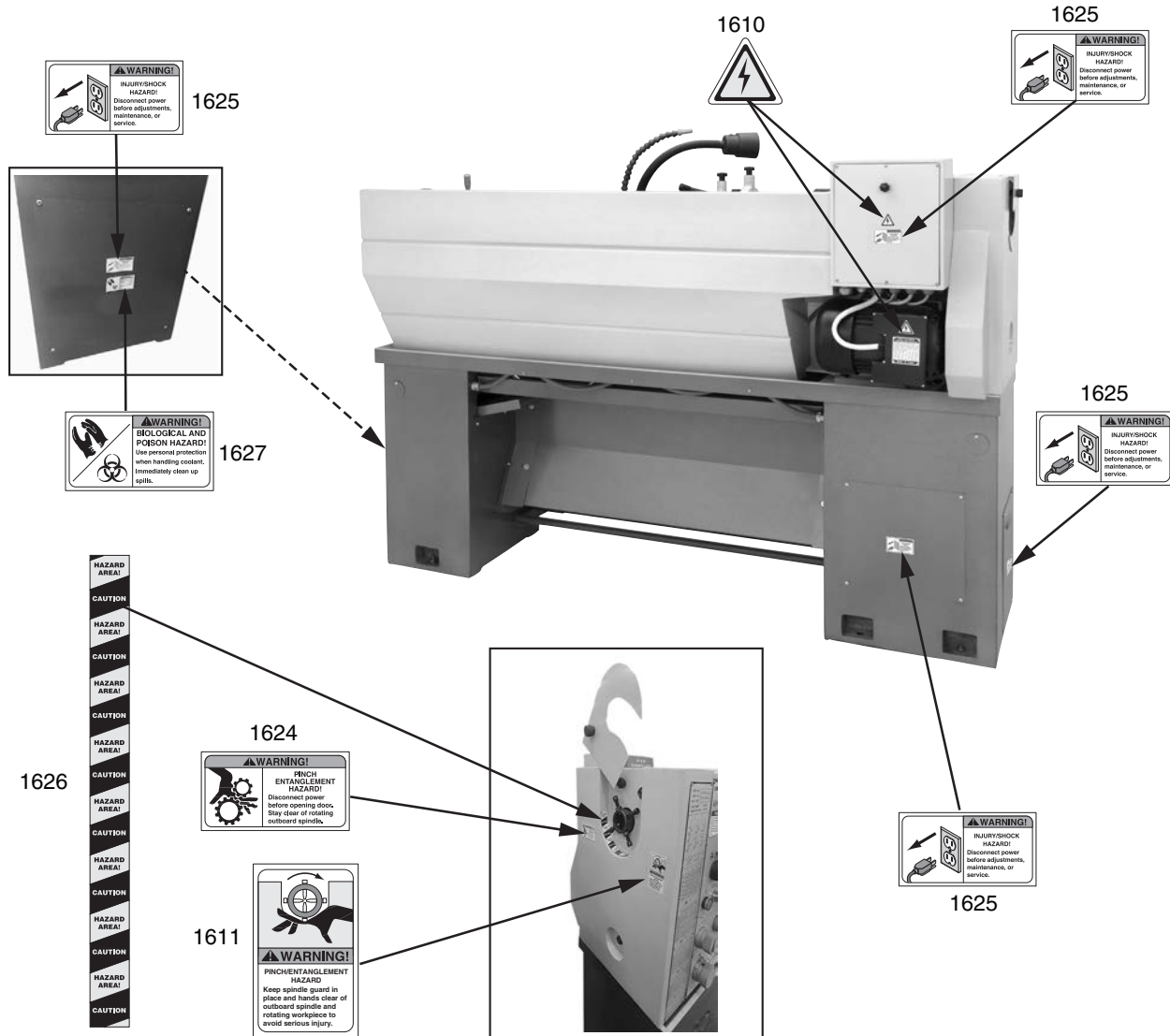


REF	PART #	DESCRIPTION
1601	P07091601	GRIZZLY NAMEPLATE-LARGE
1602	P07091602	MODEL NUMBER LABEL
1603	P07091603	GUNSMITH LATHE LABEL
1604V2	P07091604V2	MACHINE ID LABEL V2.01.21
1605	P07091605	ENTANGLEMENT LABEL 2.5 X 1.5
1606	P07091606	ENTANGLEMENT LABEL 1.5 X 2.5
1607	P07091607	DISCONNECT POWER 1.5W X 2.5H
1608	P07091608	READ MANUAL 1.5W X 2.5H
1609V2	P07091609V2	FACE SHIELD & SAFETY GLASSES LABEL V2.06.17
1610	P07091610	ELECTRICITY LABEL 1.4
1612	P07091612	TOUCH-UP PAINT, GRIZZLY GREEN

REF	PART #	DESCRIPTION
1613	P07091613	TOUCH-UP PAINT, GRIZZLY PUTTY
1614	P07091614	THREAD DIAL CHART
1615	P07091615	FEED AND THREAD CHART
1616	P07091616	TRAINED OPERATORS NOTICE LABEL
1617	P07091617	LEVERS NOTICE LABEL
1618	P07091618	SPINDLE SPEED HAZARD LABEL
1619	P07091619	IMPACT INJURY HAZARD LABEL
1620	P07091620	CARRIAGE LOCK BOLT NOTICE
1621	P07091621	FLUID CAPACITIES LABEL
1622	P07091622	STOP OIL FILL TAG
1623	P07091623	GRIZZLY.COM LABEL



# Labels & Cosmetics (Cont.)



REF	PART #	DESCRIPTION
1610	P07091610	ELECTRICITY LABEL 1.4
1611	P07091611	SPIDER ENTANGLEMENT LABEL
1624	P07091624	PINCH/ENTANGLEMENT LABEL

REF	PART #	DESCRIPTION
1625	P07091625	DISCONNECT POWER LABEL HZ
1626	P07091626	HAZARD AREA CAUTION LABEL
1627	P07091627	BIOLOGICAL/POISON HAZARD LABEL

## **⚠️ WARNING**

Safety labels help reduce the risk of serious injury caused by machine hazards. If any label comes off or becomes unreadable, the owner of this machine **MUST** replace it in the original location before resuming operations. For replacements, contact (800) 523-4777 or [www.grizzly.com](http://www.grizzly.com).



# WARRANTY & RETURNS

---

Grizzly Industrial, Inc. warrants every product it sells for a period of **1 year** to the original purchaser from the date of purchase. This warranty does not apply to defects due directly or indirectly to misuse, abuse, negligence, accidents, repairs or alterations or lack of maintenance. This is Grizzly's sole written warranty and any and all warranties that may be implied by law, including any merchantability or fitness, for any particular purpose, are hereby limited to the duration of this written warranty. We do not warrant or represent that the merchandise complies with the provisions of any law or acts unless the manufacturer so warrants. In no event shall Grizzly's liability under this warranty exceed the purchase price paid for the product and any legal actions brought against Grizzly shall be tried in the State of Washington, County of Whatcom.

We shall in no event be liable for death, injuries to persons or property or for incidental, contingent, special, or consequential damages arising from the use of our products.

The manufacturers reserve the right to change specifications at any time because they constantly strive to achieve better quality equipment. We make every effort to ensure that our products meet high quality and durability standards and we hope you never need to use this warranty.

In the event you need to use this warranty, contact us by mail or phone and give us all the details. We will then issue you a "Return Number," which must be clearly posted on the outside as well as the inside of the carton. We will not accept any item back without this number. Proof of purchase must accompany the merchandise.

Please feel free to write or call us if you have any questions about the machine or the manual.

Thank you again for your business and continued support. We hope to serve you again soon.

To take advantage of this warranty, you must register it at <https://www.grizzly.com/forms/warranty>, or you can scan the QR code below to be automatically directed to our warranty registration page. Enter all applicable information for the product.



**grizzly.com**<sup>®</sup>  
**TOOL WEBSITE**

Buy Direct and Save with Grizzly<sup>®</sup> – Trusted, Proven and a Great Value!  
~Since 1983~

*Visit Our Website Today For  
Current Specials!*

**ORDER  
24 HOURS A DAY!  
1-800-523-4777**

