

Grizzly *Industrial, Inc.*®

MODEL G0642 15-BIT LINE BORING MACHINE OWNER'S MANUAL *(For models manufactured since 11/14)*



COPYRIGHT © NOVEMBER, 2007 BY GRIZZLY INDUSTRIAL, INC., REVISED MARCH, 2018 (HE)

**WARNING: NO PORTION OF THIS MANUAL MAY BE REPRODUCED IN ANY SHAPE
OR FORM WITHOUT THE WRITTEN APPROVAL OF GRIZZLY INDUSTRIAL, INC.**

#TS9904 PRINTED IN TAIWAN

V2.03.18



WARNING!

This manual provides critical safety instructions on the proper setup, operation, maintenance, and service of this machine/tool. Save this document, refer to it often, and use it to instruct other operators.

Failure to read, understand and follow the instructions in this manual may result in fire or serious personal injury—including amputation, electrocution, or death.

The owner of this machine/tool is solely responsible for its safe use. This responsibility includes but is not limited to proper installation in a safe environment, personnel training and usage authorization, proper inspection and maintenance, manual availability and comprehension, application of safety devices, cutting/sanding/grinding tool integrity, and the usage of personal protective equipment.

The manufacturer will not be held liable for injury or property damage from negligence, improper training, machine modifications or misuse.



WARNING!

Some dust created by power sanding, sawing, grinding, drilling, and other construction activities contains chemicals known to the State of California to cause cancer, birth defects or other reproductive harm. Some examples of these chemicals are:

- **Lead from lead-based paints.**
- **Crystalline silica from bricks, cement and other masonry products.**
- **Arsenic and chromium from chemically-treated lumber.**

Your risk from these exposures varies, depending on how often you do this type of work. To reduce your exposure to these chemicals: Work in a well ventilated area, and work with approved safety equipment, such as those dust masks that are specially designed to filter out microscopic particles.

Table of Contents

INTRODUCTION	2	SECTION 5: ACCESSORIES	23
Manual Accuracy	2	SECTION 6: MAINTENANCE	25
Contact Info.....	2	Schedule	25
Identification.....	3	Cleaning.....	25
Machine Data Sheet	4	Lubrication	25
SECTION 1: SAFETY	5	SECTION 7: SERVICE	27
Safety Instructions for Machinery	5	Troubleshooting	27
Additional Safety for Line Boring Machines...	7	Adjusting Table Parallel to Boring Head.....	29
SECTION 2: POWER SUPPLY	8	Aligning Boring Bit Height.....	30
SECTION 3: SETUP	10	Wiring Diagram	31
Setup Safety	10	SECTION 8: PARTS	32
Items Needed for Setup.....	10	Column & Electrical	32
Unpacking	10	Table	34
Inventory	11	Cabinet & Tools	36
Clean Up.....	12	Boring Head.....	37
Site Considerations.....	13	Labels & Cosmetics	38
Mounting to Shop Floor	14	WARRANTY AND RETURNS	39
Lifting & Placing	15		
Assembly	16		
Test Run	17		
SECTION 4: OPERATIONS	18		
Disabling & Locking Switch.....	18		
Installing Boring Bits	19		
Adjusting Drilling Depth	20		
Adjusting Hold-Down Height.....	21		
Positioning the Workpiece	21		
Drilling Overview	22		

INTRODUCTION

Manual Accuracy

We are proud to provide a high-quality owner's manual with your new machine!

We made every effort to be exact with the instructions, specifications, drawings, and photographs in this manual. Sometimes we make mistakes, but our policy of continuous improvement also means that **sometimes the machine you receive is slightly different than shown in the manual.**

If you find this to be the case, and the difference between the manual and machine leaves you confused or unsure about something, check our website for an updated version. We post current manuals and manual updates for free on our website at **www.grizzly.com**.

Alternatively, you can call our Technical Support for help. Before calling, make sure you write down the **Manufacture Date** and **Serial Number** from the machine ID label (see below). This information is required for us to provide proper tech support, and it helps us determine if updated documentation is available for your machine.

Contact Info

We stand behind our machines! If you have questions or need help, contact us with the information below. Before contacting, make sure you get the **serial number** and **manufacture date** from the machine ID label. This will help us help you faster.

Grizzly Technical Support
1815 W. Battlefield
Springfield, MO 65807
Phone: (570) 546-9663
Email: techsupport@grizzly.com

We want your feedback on this manual. What did you like about it? Where could it be improved? Please take a few minutes to give us feedback.

Grizzly Documentation Manager
P.O. Box 2069
Bellingham, WA 98227-2069
Email: manuals@grizzly.com

		MODEL GXXXX	
		MACHINE NAME	
SPECIFICATIONS		⚠ WARNING!	
Motor:	To reduce risk of serious injury when using this machine:		
Specification:	Read manual before operation.		
Specification:	Wear safety glasses and respirator.		
Specification:	Ensure machine is properly adjusted/setup and		
Specification:	power is connected to grounded circuit before starting.		
Weight:	4. Make sure the motor has stopped and disconnect		
	power before adjustments, maintenance, or service.		
	5. DO NOT expose to rain or dampness.		
	6. DO NOT modify this machine in any way.		
	7.		
	8.		
	9. Do not use while under the influence of drugs or alcohol.		
	10. Maintain machine carefully to prevent accidents.		
	Manufactured for Grizzly in Taiwan		

Manufacture Date (indicated by an arrow pointing to the date field in the specifications section)

Serial Number (indicated by an arrow pointing to the serial number field in the specifications section)



Identification

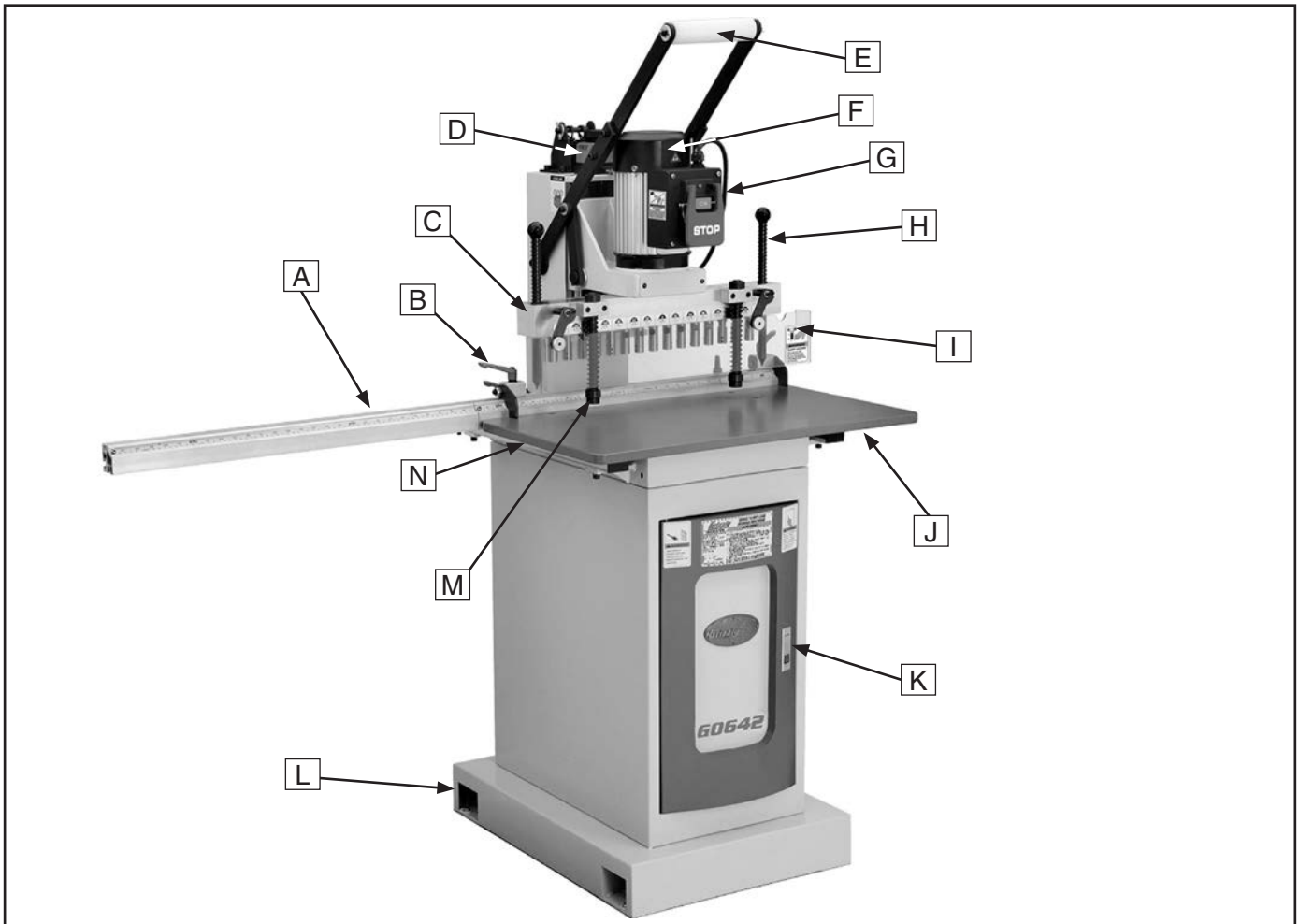

Figure 1. Model G0642 identification.

- | | |
|--|---------------------------|
| A. Longitudinal Fence and Scale | H. Indexing Pin |
| B. Longitudinal Locking Lever and Stop | I. Boring Head Guard |
| C. Boring Head Assembly | J. Table |
| D. Drilling Depth Control | K. Cabinet Door |
| E. Downfeed Handle | L. Cabinet Mounting Point |
| F. 1 HP Motor | M. Workpiece Hold-down |
| G. ON/OFF Switch | N. Cross Fence and Scale |



Basic Controls

Refer to **Figure 2** and the following descriptions to become familiar with the basic controls of this machine.

- A. Workpiece Hold-Down:** Secures the workpiece firmly against the table and fence. Adjusts to accommodate different workpiece thicknesses.
- B. Fence Extension and Scale:** Mounts on the left end of the table fence for longer workpieces.
- C. Fence Locking Lever and Stops:** Mount anywhere along the fence so holes can be drilled in multiple workpieces at the same location.
- D. Drilling Depth Control:** Sets the maximum boring bit depth.
- E. Downfeed Handle:** Raises and lowers boring bits for drilling operations.
- F. ON/OFF Switch:** Starts and stops motor.
- G. Throat Position Lock:** Locks the boring head lateral position when adjusting the set-back distance.
- H. Indexing Pin:** Positions the workpiece for additional drilling beyond 15 holes.
- I. Throat Adjustment Knob:** Adjusts the boring head bit position laterally.
- J. Table Fence and Scale:** The fence supports the workpiece during the boring operation. The fence scale is used to position the workpiece relative to the boring bits.

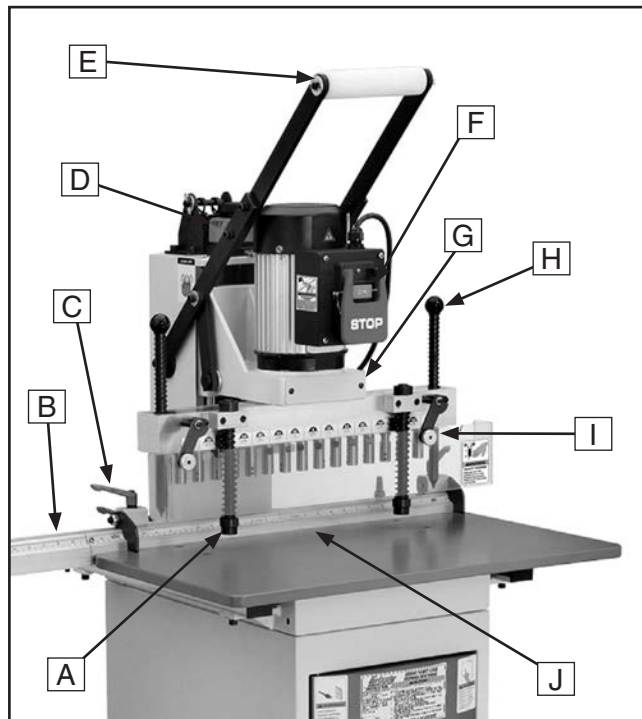

Figure 2. Model G0642 basic controls.

WARNING

Like all machinery there is potential danger when operating this machine. Accidents are frequently caused by lack of familiarity or failure to pay attention. Use this machine with respect and caution to decrease the risk of operator injury. If normal safety precautions are overlooked or ignored, serious personal injury may occur.

WARNING

No list of safety guidelines can be complete. Every shop environment is different. Always consider safety first, as it applies to your individual working conditions. Use this and other machinery with caution and respect. Failure to do so could result in serious personal injury, damage to equipment, or poor work results.





MACHINE DATA SHEET

Customer Service #: (570) 546-9663 · To Order Call: (800) 523-4777 · Fax #: (800) 438-5901

MODEL G0642 15 BIT LINE BORING MACHINE

Product Dimensions:

Weight..... 242 lbs.
Width (side-to-side) x Depth (front-to-back) x Height..... 28 x 25-3/4 x 62-5/8 in.
Footprint (Length x Width)..... 19-5/8 x 25-3/4 in.

Shipping Dimensions:

Type..... Cardboard
Content..... Machine
Weight..... 276 lbs.
Length x Width x Height..... 32 x 29 x 63 in.
Must Ship Upright..... Yes

Electrical:

Power Requirement..... 110V or 220V, Single-Phase, 60 Hz
Prewired Voltage..... 110V
Full-Load Current Rating..... 10A at 110V, 5A at 220V
Minimum Circuit Size..... 15A at 110V, 15A at 220V
Connection Type..... Cord & Plug
Power Cord Included..... Yes
Power Cord Length..... 9-1/2 ft.
Power Cord Gauge..... 14 AWG
Plug Included..... Yes
Included Plug Type..... 5-15
Switch Type..... ON/OFF Push Button Switch w/Large Shut-Off Paddle

Motors:

Main

Horsepower..... 1 HP
Phase..... Single-Phase
Amps..... 10A/5A
Speed..... 3450 RPM
Type..... TEFC Capacitor-Start Induction
Power Transfer Gear Drive
Bearings..... Shielded & Permanently Lubricated

Main Specifications:

Operation Information

Spindle Travel..... 3 in.
Spindle RPM..... 3450
Maximum Stock Width..... 12-1/2 in.
Drill Bit Type..... Flat Shank Boring Bit
Bit Cap..... 10 mm

Table Information

Table Travel Front To Back..... 8 in.
Floor To Table Height..... 34-1/4 in.
Table Size Length..... 28 in.
Table Size Width..... 15-3/4 in.
Table Size Thickness..... 3/4 in.



SECTION 1: SAFETY

For Your Own Safety, Read Instruction Manual Before Operating This Machine

The purpose of safety symbols is to attract your attention to possible hazardous conditions. This manual uses a series of symbols and signal words intended to convey the level of importance of the safety messages. The progression of symbols is described below. Remember that safety messages by themselves do not eliminate danger and are not a substitute for proper accident prevention measures. Always use common sense and good judgment.

 **DANGER** Indicates an imminently hazardous situation which, if not avoided, **WILL** result in death or serious injury.

 **WARNING** Indicates a potentially hazardous situation which, if not avoided, **COULD** result in death or serious injury.

 **CAUTION** Indicates a potentially hazardous situation which, if not avoided, **MAY** result in minor or moderate injury. It may also be used to alert against unsafe practices.

NOTICE This symbol is used to alert the user to useful information about proper operation of the machine.

Safety Instructions for Machinery

WARNING

OWNER'S MANUAL. Read and understand this owner's manual **BEFORE** using machine.

TRAINED OPERATORS ONLY. Untrained operators have a higher risk of being hurt or killed. Only allow trained/supervised people to use this machine. When machine is not being used, disconnect power, remove switch keys, or lock-out machine to prevent unauthorized use—especially around children. Make your workshop kid proof!

DANGEROUS ENVIRONMENTS. Do not use machinery in areas that are wet, cluttered, or have poor lighting. Operating machinery in these areas greatly increases the risk of accidents and injury.

MENTAL ALERTNESS REQUIRED. Full mental alertness is required for safe operation of machinery. Never operate under the influence of drugs or alcohol, when tired, or when distracted.

ELECTRICAL EQUIPMENT INJURY RISKS. You can be shocked, burned, or killed by touching live electrical components or improperly grounded machinery. To reduce this risk, only allow qualified service personnel to do electrical installation or repair work, and always disconnect power before accessing or exposing electrical equipment.

DISCONNECT POWER FIRST. Always disconnect machine from power supply **BEFORE** making adjustments, changing tooling, or servicing machine. This prevents an injury risk from unintended startup or contact with live electrical components.

EYE PROTECTION. Always wear ANSI-approved safety glasses or a face shield when operating or observing machinery to reduce the risk of eye injury or blindness from flying particles. Everyday eyeglasses are **NOT** approved safety glasses.



WARNING

WEARING PROPER APPAREL. Do not wear clothing, apparel or jewelry that can become entangled in moving parts. Always tie back or cover long hair. Wear non-slip footwear to reduce risk of slipping and losing control or accidentally contacting cutting tool or moving parts.

HAZARDOUS DUST. Dust created by machinery operations may cause cancer, birth defects, or long-term respiratory damage. Be aware of dust hazards associated with each workpiece material. Always wear a NIOSH-approved respirator to reduce your risk.

HEARING PROTECTION. Always wear hearing protection when operating or observing loud machinery. Extended exposure to this noise without hearing protection can cause permanent hearing loss.

REMOVE ADJUSTING TOOLS. Tools left on machinery can become dangerous projectiles upon startup. Never leave chuck keys, wrenches, or any other tools on machine. Always verify removal before starting!

USE CORRECT TOOL FOR THE JOB. Only use this tool for its intended purpose—do not force it or an attachment to do a job for which it was not designed. Never make unapproved modifications—modifying tool or using it differently than intended may result in malfunction or mechanical failure that can lead to personal injury or death!

AWKWARD POSITIONS. Keep proper footing and balance at all times when operating machine. Do not overreach! Avoid awkward hand positions that make workpiece control difficult or increase the risk of accidental injury.

CHILDREN & BYSTANDERS. Keep children and bystanders at a safe distance from the work area. Stop using machine if they become a distraction.

GUARDS & COVERS. Guards and covers reduce accidental contact with moving parts or flying debris. Make sure they are properly installed, undamaged, and working correctly **BEFORE** operating machine.

FORCING MACHINERY. Do not force machine. It will do the job safer and better at the rate for which it was designed.

NEVER STAND ON MACHINE. Serious injury may occur if machine is tipped or if the cutting tool is unintentionally contacted.

STABLE MACHINE. Unexpected movement during operation greatly increases risk of injury or loss of control. Before starting, verify machine is stable and mobile base (if used) is locked.

USE RECOMMENDED ACCESSORIES. Consult this owner's manual or the manufacturer for recommended accessories. Using improper accessories will increase the risk of serious injury.

UNATTENDED OPERATION. To reduce the risk of accidental injury, turn machine **OFF** and ensure all moving parts completely stop before walking away. Never leave machine running while unattended.

MAINTAIN WITH CARE. Follow all maintenance instructions and lubrication schedules to keep machine in good working condition. A machine that is improperly maintained could malfunction, leading to serious personal injury or death.

DAMAGED PARTS. Regularly inspect machine for damaged, loose, or mis-adjusted parts—or any condition that could affect safe operation. Immediately repair/replace **BEFORE** operating machine. For your own safety, **DO NOT** operate machine with damaged parts!

MAINTAIN POWER CORDS. When disconnecting cord-connected machines from power, grab and pull the plug—**NOT** the cord. Pulling the cord may damage the wires inside. Do not handle cord/plug with wet hands. Avoid cord damage by keeping it away from heated surfaces, high traffic areas, harsh chemicals, and wet/damp locations.

EXPERIENCING DIFFICULTIES. If at any time you experience difficulties performing the intended operation, stop using the machine! Contact our Technical Support at (570) 546-9663.



Additional Safety for Boring Machines

WARNING

Serious injury or death can occur from getting clothing, jewelry, or long hair entangled in rotating boring bit. Contact with rotating boring bit can result in severe cuts or amputation of fingers. Flying debris can cause blindness or eye injuries. Broken bits, unsecured workpieces, or other adjustment tools thrown from rotating chucks can strike nearby operator or bystanders with deadly force. To reduce the risk of these hazards, operator and bystanders **MUST** completely heed hazards and warnings below.

WEARING PROPER PPE. Flying chips created by drilling can cause eye injuries or blindness. Always wear a face shield in addition to safety glasses. Always keep hands and fingers away from drill bit/cutting tool. Avoid awkward hand positions, where a sudden slip could cause hand to move into bit/cutting tool.

AVOIDING ENTANGLEMENT. DO NOT wear loose clothing, gloves, or jewelry, and tie back long hair. Keep all guards in place and secure. Always allow spindle to stop on its own. DO NOT stop spindle using your hand or any other object.

REMOVING ADJUSTMENT TOOLS. Chuck key, drawbar wrench, and other tools left on machine can become deadly projectiles when spindle is started. Remove all loose items or tools used on spindle immediately after use.

SECURING BIT/CUTTING TOOL. Firmly secure bit/cutting tool so it does not fly out of spindle during operation or startup.

SECURING TABLE AND HEADSTOCK. To avoid accidental contact with tool/bit, tighten all table and headstock locks before operating drill.

CORRECT SPINDLE SPEED. Using wrong spindle speed can cause bits/cutting tools to break and strike operator or bystanders. Follow recommended speeds and feeds for each size/type of bit/cutting tool and workpiece material.

WORKPIECE PREPARATION. To avoid loss of workpiece control, DO NOT drill material with an uneven surface on the table, unless a suitable support is used. To avoid impact injuries, make sure workpiece is free of nails or foreign objects in area to be drilled.

WORKPIECE CONTROL. An unsecured workpiece may unexpectedly shift, spin out of control, or be thrown if bit/cutting tool “grabs” during operation. Clamp workpiece to table or in table-mounted vise, or brace against column to prevent rotation. NEVER hold workpiece by hand during operation. NEVER start machine with bit/cutting tool touching workpiece; allow spindle to gain full speed before drilling.

INSPECTING BIT/CUTTING TOOL. Damaged bits/cutting tools may break apart during operation and hit operator or bystanders. Dull bits/cutting tools increase cutting resistance and are more likely to grab and spin/throw workpiece. Always inspect bits/cutting tools for sharpness, chips, or cracks before each use. Replace dull, chipped, or cracked bits/cutting tools immediately.

MAINTAINING MACHINE. Keep machine in proper working condition to help ensure that it functions safely and all guards and other components work as intended. Perform routine inspections and all necessary maintenance. Never operate machine with damaged or worn parts that can break or result in unexpected movement during operation.

CLEANING MACHINE SAFELY. To avoid contact with tool/bit, never clear chips while spindle is turning. To avoid cuts and eye injuries, DO NOT clear chips by hand or with compressed air—use a brush or vacuum instead.

DISCONNECT POWER FIRST. To reduce risk of electrocution or injury from unexpected startup, make sure drill is turned **OFF**, disconnected from power, and all moving parts have come to a complete stop before changing bits/cutting tools or starting any inspection, adjustment, or maintenance procedure.



SECTION 2: POWER SUPPLY

Availability

Before installing the machine, consider the availability and proximity of the required power supply circuit. If an existing circuit does not meet the requirements for this machine, a new circuit must be installed. To minimize the risk of electrocution, fire, or equipment damage, installation work and electrical wiring must be done by an electrician or qualified service personnel in accordance with all applicable codes and standards.

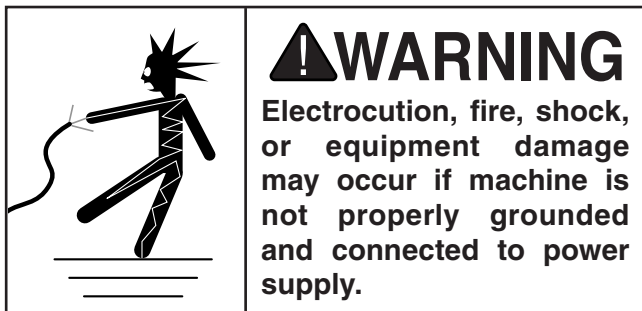

Full-Load Current Rating

The full-load current rating is the amperage a machine draws at 100% of the rated output power. On machines with multiple motors, this is the amperage drawn by the largest motor or sum of all motors and electrical devices that might operate at one time during normal operations.

Full-Load Current Rating at 110V..... 10 Amps

Full-Load Current Rating at 220V 5 Amps

The full-load current is not the maximum amount of amps that the machine will draw. If the machine is overloaded, it will draw additional amps beyond the full-load rating.

If the machine is overloaded for a sufficient length of time, damage, overheating, or fire may result—especially if connected to an undersized circuit. To reduce the risk of these hazards, avoid overloading the machine during operation and make sure it is connected to a power supply circuit that meets the specified circuit requirements.

Circuit Information

A power supply circuit includes all electrical equipment between the breaker box or fuse panel in the building and the machine. The power supply circuit used for this machine must be sized to safely handle the full-load current drawn from the machine for an extended period of time. (If this machine is connected to a circuit protected by fuses, use a time delay fuse marked D.)

! CAUTION
For your own safety and protection of property, consult an electrician if you are unsure about wiring practices or electrical codes in your area.

Note: *Circuit requirements in this manual apply to a dedicated circuit—where only one machine will be running on the circuit at a time. If machine will be connected to a shared circuit where multiple machines may be running at the same time, consult an electrician or qualified service personnel to ensure circuit is properly sized for safe operation.*

Circuit Requirements for 110V

This machine is prewired to operate on a power supply circuit that has a verified ground and meets the following requirements:

Nominal Voltage 110V, 115V, 120V
Cycle 60 Hz
Phase Single-Phase
Power Supply Circuit 15 Amps
Plug/Receptacle NEMA 5-15

Circuit Requirements for 220V

This machine can be converted to operate on a power supply circuit that has a verified ground and meets the requirements listed below. (Refer to **Voltage Conversion** instructions for details.)

Nominal Voltage 208V, 220V, 230V, 240V
Cycle 60 Hz
Phase Single-Phase
Power Supply Circuit 15 Amps
Plug/Receptacle NEMA 6-15



Grounding Requirements

This machine **MUST** be grounded. In the event of certain malfunctions or breakdowns, grounding reduces the risk of electric shock by providing a path of least resistance for electric current.

For 110V operation: This machine is equipped with a power cord that has an equipment-grounding wire and a grounding plug (see following figure). The plug must only be inserted into a matching receptacle (outlet) that is properly installed and grounded in accordance with all local codes and ordinances.

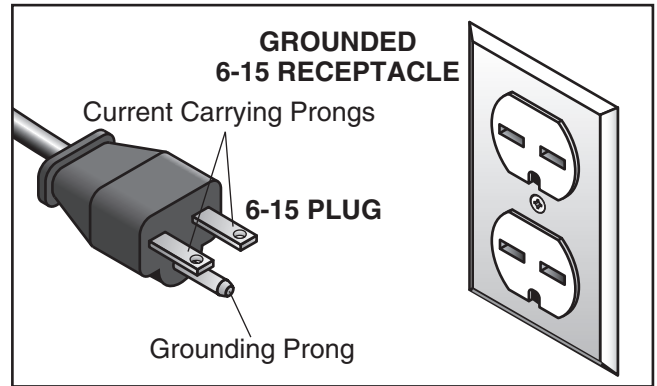

Figure 4. Typical 6-15 plug and receptacle.

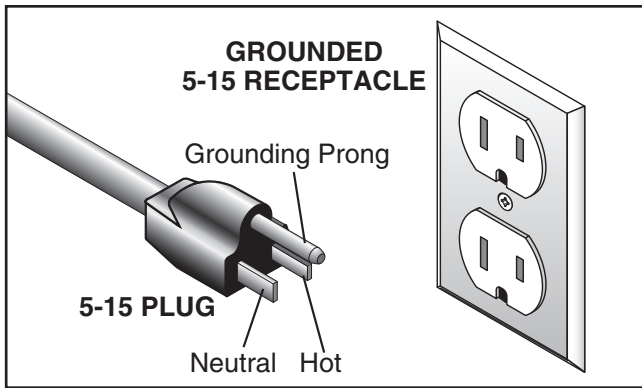

Figure 3. Typical 5-15 plug and receptacle.

Improper connection of the equipment-grounding wire can result in a risk of electric shock. The wire with green insulation (with or without yellow stripes) is the equipment-grounding wire. If repair or replacement of the power cord or plug is necessary, do not connect the equipment-grounding wire to a live (current carrying) terminal.

Check with a qualified electrician or service personnel if you do not understand these grounding requirements, or if you are in doubt about whether the tool is properly grounded. If you ever notice that a cord or plug is damaged or worn, disconnect it from power, and immediately replace it with a new one.

⚠ CAUTION

SHOCK HAZARD!

Two-prong outlets do not meet the grounding requirements for this machine. Do not modify or use an adapter on the plug provided—if it will not fit the outlet, have a qualified electrician install the proper outlet with a verified ground.

Extension Cords

We do not recommend using an extension cord with this machine. If you must use an extension cord, only use it if absolutely necessary and only on a temporary basis.

Extension cords cause voltage drop, which can damage electrical components and shorten motor life. Voltage drop increases as the extension cord size gets longer and the gauge size gets smaller (higher gauge numbers indicate smaller sizes).

Any extension cord used with this machine must be in good condition and contain a ground wire and matching plug/receptacle. Additionally, it must meet the following size requirements:

- Minimum Gauge Size 12 AWG**
- Maximum Length (Shorter is Better).....50 ft.**

For 220V operation: The plug specified under “Circuit Requirements for 220V” on the previous page has a grounding prong that must be attached to the equipment-grounding wire on the included power cord. The plug must only be inserted into a matching receptacle (see following figure) that is properly installed and grounded in accordance with all local codes and ordinances.



Voltage Conversion

This section shows how to convert the Model G0642 from 110V to 220V. The plug needed for this conversion can be purchased at any local hardware store or electrical supply store.

Items Needed	Qty
• Phillips Head Screwdriver #2	1
• NEMA 6-15 Plug	1
• Wire Cutters	1
• Wire Strippers.....	1

NOTICE

This manual was current at the time of printing; however, if the wiring diagram provided on the inside cover of the motor junction box conflicts with this manual, always use that wiring diagram instead, as it will reflect any changes that may have occurred after printing.

To convert to 220V:

1. DISCONNECT BORING MACHINE FROM POWER!
2. Cut off the pre-installed 5-15 plug from the end of the power cord.
3. Open the motor junction box (see **Figure 5**) by removing the four screws from the front.

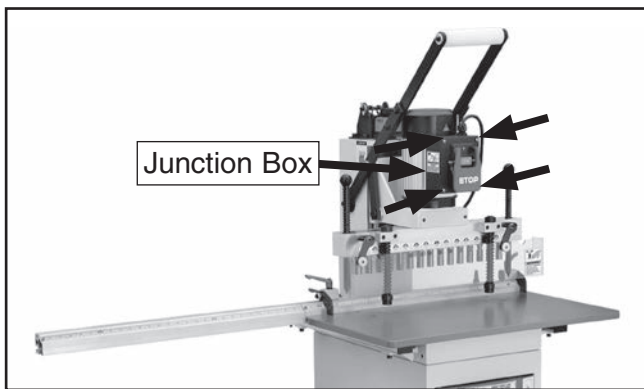

Figure 5. Motor junction box and screw locations.

4. Loosen the screws indicated in **Figure 6**.

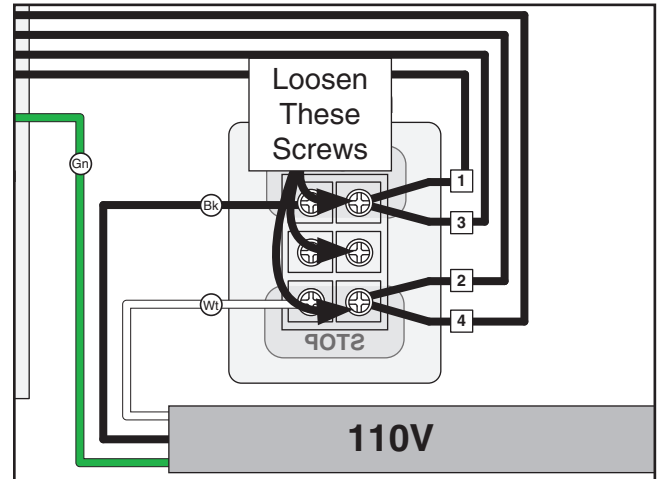

Figure 6. Location of screws to be loosened.

5. Reposition wires 1–4 as shown in **Figure 7**, then tighten the screws loosened in **Step 4**.

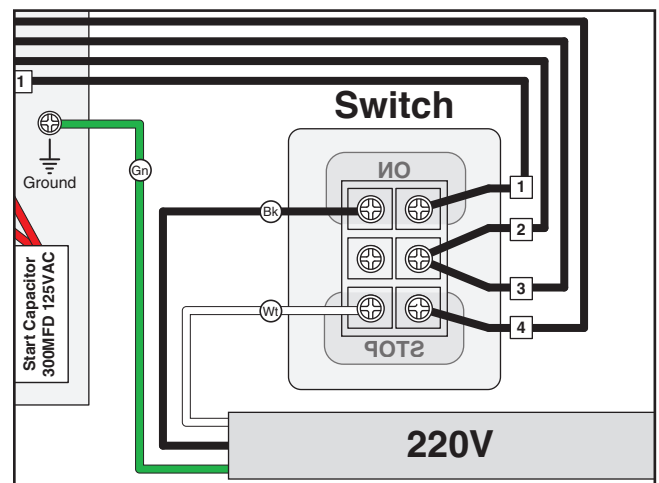

Figure 7. Motor rewired for 220V.

6. Close and secure the motor junction box.
7. Install a 6-15 plug on the end of the cord, according to the instructions and wiring diagrams provided by the plug manufacturer.

—If instructions and a wiring diagram are not provided by the plug manufacturer, the wiring diagram shown on **Page 34** shows the wiring of a standard NEMA 6-15 plug. This diagram may be used as long as your plug matches the one shown.



SECTION 3: SETUP

Setup Safety

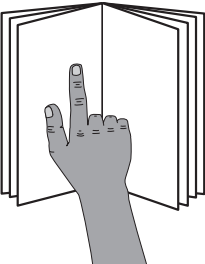

!WARNING
This machine presents serious injury hazards to untrained users. Read through this entire manual to become familiar with the controls and operations before starting the machine!



!WARNING
Wear safety glasses or a face shield during the entire setup process!



!WARNING
This machine and its components are very heavy. Use assistants and safe methods to lift and move this machine.

Items Needed for Setup

The following items are needed to complete the setup process, but are not included with your machine:

Description	Qty
• Assistants (for moving machine).....	2
• Accurate Level.....	1
• Eye & Face Protection (for each person)...	1

Unpacking

This machine was carefully packaged for safe transport. When unpacking, separate all enclosed items from packaging materials and inspect them for shipping damage. ***If items are damaged, please call us immediately at (570) 546-9663.***

IMPORTANT: Save all packaging materials until you are completely satisfied with the machine and have resolved any issues between Grizzly or the shipping agent. ***You MUST have the original packaging to file a freight claim. It is also extremely helpful if you need to return your machine later.***



!WARNING
SUFFOCATION HAZARD!
Keep children and pets away from plastic bags or packing materials shipped with this machine. Discard immediately.



Inventory

The following is a list of items shipped with your machine. Before beginning setup, lay these items out and inventory them.

If any non-proprietary parts are missing (e.g. a nut or a washer), we will gladly replace them; or for the sake of expediency, replacements can be obtained at your local hardware store.

NOTICE

If you cannot find an item on this list, carefully check around/inside the machine and packaging materials. Often, these items get lost in packaging materials while unpacking or they are pre-installed at the factory.

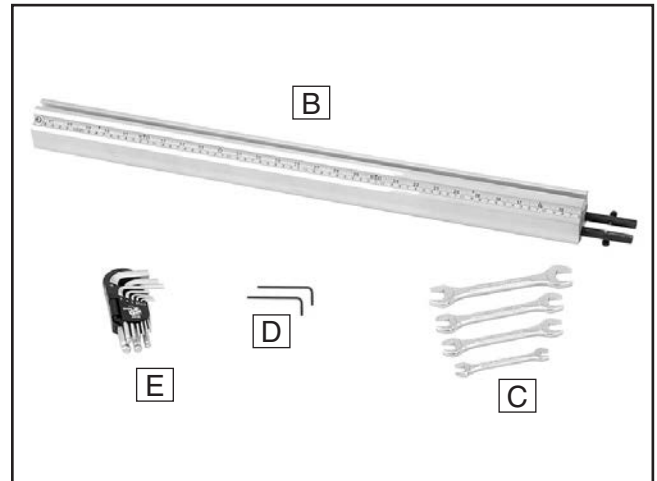

Figure 8. G0642 inventory.

Inventory (Figure 8):	Qty
A. Boring Machine (not shown).....	1
B. Longitudinal Fence Extension	1
C. Combo Open-End Wrenches 8/10mm, 11/13 mm, 12/14mm, 17/19mm	1 Each
D. Hex Wrenches 2.5mm.....	2
E. Hex Wrench Set 1.5, 2, 2.5, 3, 4, 5, 6, 8, & 10mm.....	1 Each
F. Set Screws M5-.8 x 5mm (not shown)	30



Hardware Recognition Chart

USE THIS CHART TO MATCH UP
HARDWARE DURING THE INVENTORY
AND ASSEMBLY PROCESS.

MEASURE BOLT DIAMETER BY PLACING INSIDE CIRCLE

#10

1/4"

5/16"

3/8"

7/16"

1/2"

4mm

5mm

6mm

8mm

10mm

12mm

16mm



Hex Wrench

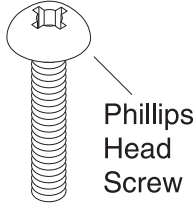

Phillips Head Screw

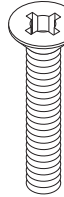

Flat Head Screw

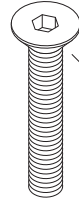

Flat Head Cap Screw

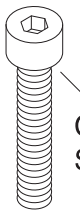

Cap Screw

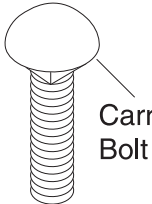

Carriage Bolt

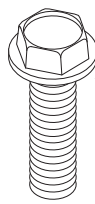

Flange Bolt

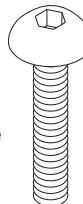

Button Head Screw



Tap Screw



External Retaining Ring



Internal Retaining Ring



E-Clip



Set Screw

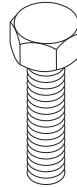

Hex Bolt



Key



Flat Washer



Lock Washer



Hex Nut

LINES ARE 1MM APART

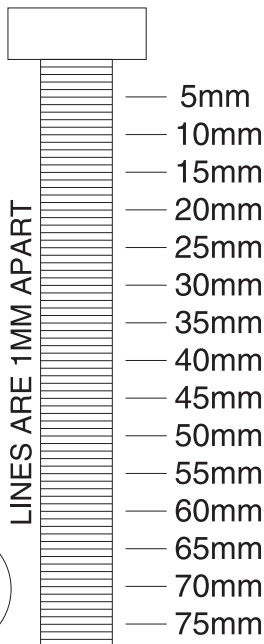

LINES ARE 1/16" INCH APART

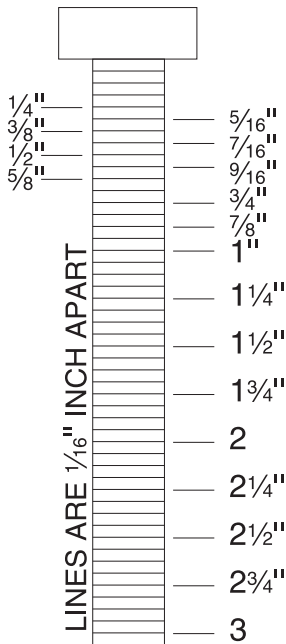

WASHERS ARE MEASURED BY THE INSIDE DIAMETER

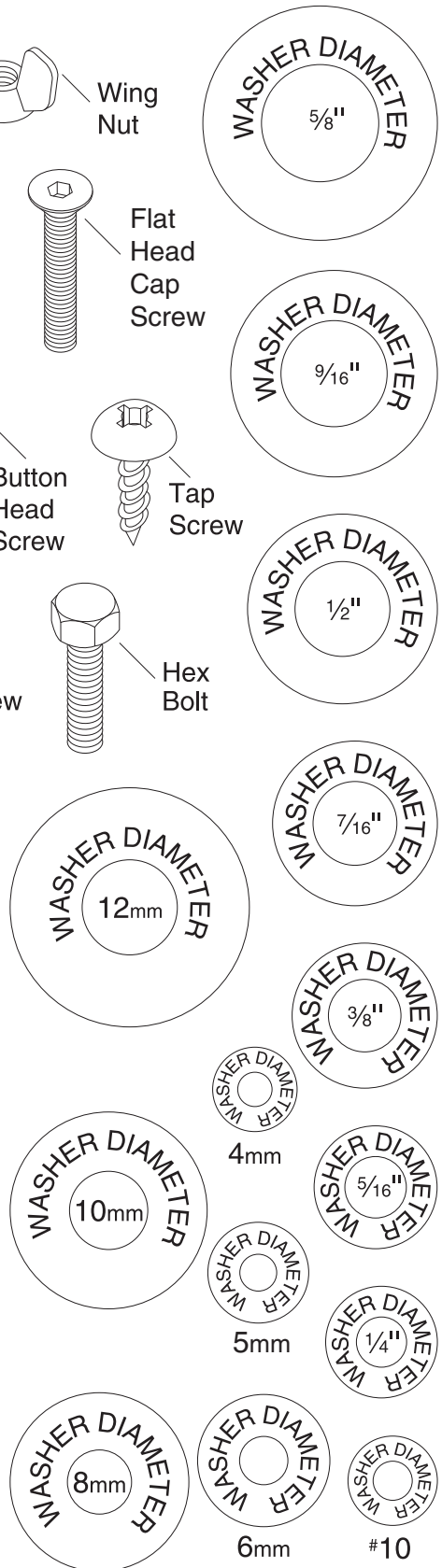

Cleanup

The unpainted surfaces of your machine are coated with a heavy-duty rust preventative that prevents corrosion during shipment and storage. This rust preventative works extremely well, but it will take a little time to clean.

Be patient and do a thorough job cleaning your machine. The time you spend doing this now will give you a better appreciation for the proper care of your machine's unpainted surfaces.

There are many ways to remove this rust preventative, but the following steps work well in a wide variety of situations. Always follow the manufacturer's instructions with any cleaning product you use and make sure you work in a well-ventilated area to minimize exposure to toxic fumes.

Before cleaning, gather the following:

- Disposable rags
- Cleaner/degreaser (WD•40 works well)
- Safety glasses & disposable gloves
- Plastic paint scraper (optional)

Basic steps for removing rust preventative:

1. Put on safety glasses.
2. Coat the rust preventative with a liberal amount of cleaner/degreaser, then let it soak for 5–10 minutes.
3. Wipe off the surfaces. If your cleaner/degreaser is effective, the rust preventative will wipe off easily. If you have a plastic paint scraper, scrape off as much as you can first, then wipe off the rest with the rag.
4. Repeat **Steps 2–3** as necessary until clean, then coat all unpainted surfaces with a quality metal protectant to prevent rust.

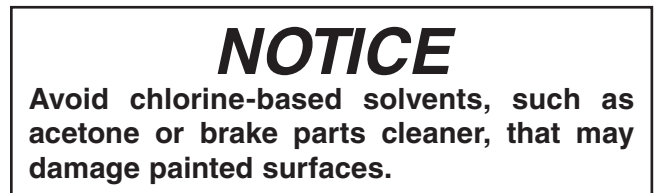
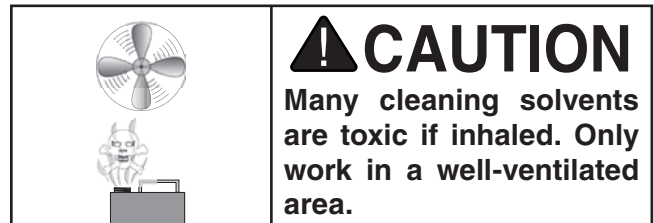
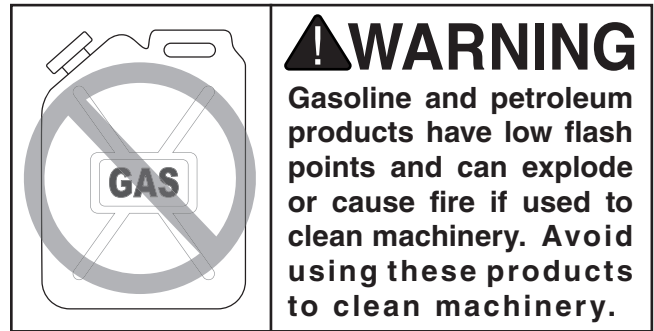

T23692—Orange Power Degreaser

A great product for removing the waxy shipping grease from the **non-painted** parts of the machine during clean up.



Figure 9. T23692 Orange Power Degreaser.



Site Considerations

Weight Load

Refer to the **Machine Data Sheet** for the weight of your machine. Make sure that the surface upon which the machine is placed will bear the weight of the machine, additional equipment that may be installed on the machine, and the heaviest workpiece that will be used. Additionally, consider the weight of the operator and any dynamic loading that may occur when operating the machine.

Space Allocation

Consider the largest size of workpiece that will be processed through this machine and provide enough space around the machine for adequate operator material handling or the installation of auxiliary equipment. With permanent installations, leave enough space around the machine to open or remove doors/covers as required by the maintenance and service described in this manual. **See below for required space allocation.**

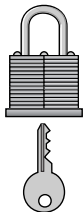
	<p>CAUTION</p> <p>Children or untrained people may be seriously injured by this machine. Only install in an access restricted location.</p>
---	--

Physical Environment

The physical environment where the machine is operated is important for safe operation and longevity of machine components. For best results, operate this machine in a dry environment that is free from excessive moisture, hazardous chemicals, airborne abrasives, or extreme conditions. Extreme conditions for this type of machinery are generally those where the ambient temperature range exceeds 41°–104°F; the relative humidity range exceeds 20%–95% (non-condensing); or the environment is subject to vibration, shocks, or bumps.

Electrical Installation

Place this machine near an existing power source. Make sure all power cords are protected from traffic, material handling, moisture, chemicals, or other hazards. Make sure to leave enough space around machine to disconnect power supply or apply a lockout/tagout device, if required.

Lighting

Lighting around the machine must be adequate enough that operations can be performed safely. Shadows, glare, or strobe effects that may distract or impede the operator must be eliminated.

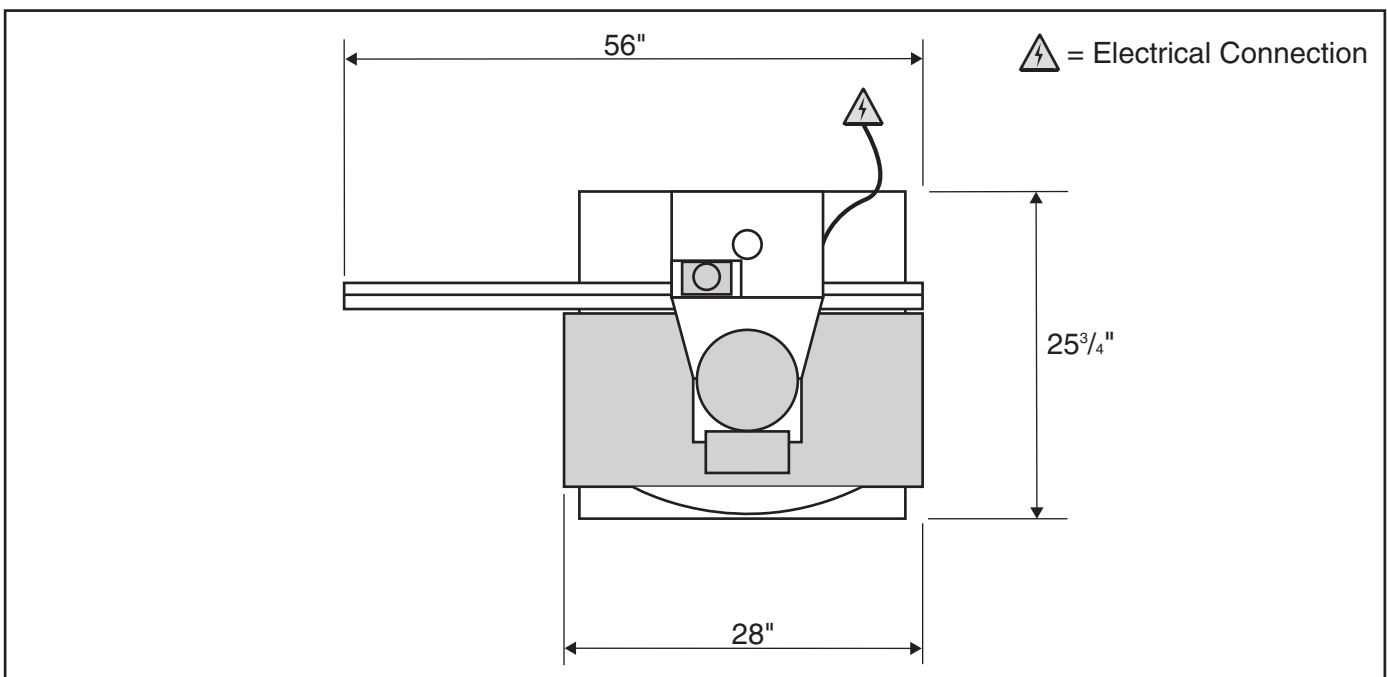

Figure 10. Minimum working clearances.



Anchoring to Floor

Anchoring machinery to the floor prevents tipping or shifting and reduces vibration that may occur during operation, resulting in a machine that runs slightly quieter and feels more solid.

If the machine will be installed in a commercial or workplace setting, or if it is permanently connected (hardwired) to the power supply, local codes may require that it be anchored to the floor.

If not required by any local codes, fastening the machine to the floor is an optional step. If you choose not to do this with your machine, we recommend placing it on machine mounts, as these provide an easy method for leveling and they have vibration-absorbing pads.

Anchoring to Concrete Floors

Lag shield anchors with lag screws (see below) are a popular way to anchor machinery to a concrete floor, because the anchors sit flush with the floor surface, making it easy to unbolt and move the machine later, if needed. However, anytime local codes apply, you **MUST** follow the anchoring methodology specified by the code.

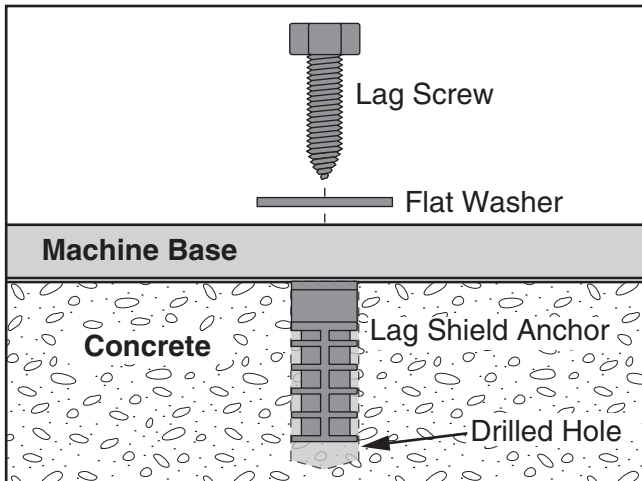

Figure 11. Popular method for anchoring machinery to a concrete floor.

Using Machine Mounts

Using machine mounts, shown in **Figure 12**, gives the advantage of fast leveling and vibration reduction. The large size of the foot pads distributes the weight of the machine to reduce strain on the floor.



Figure 12. Machine mount example.

NOTICE

We strongly recommend securing your machine to the floor if it is hardwired to the power source. Consult with your electrician to ensure compliance with local codes.



Lifting & Placing

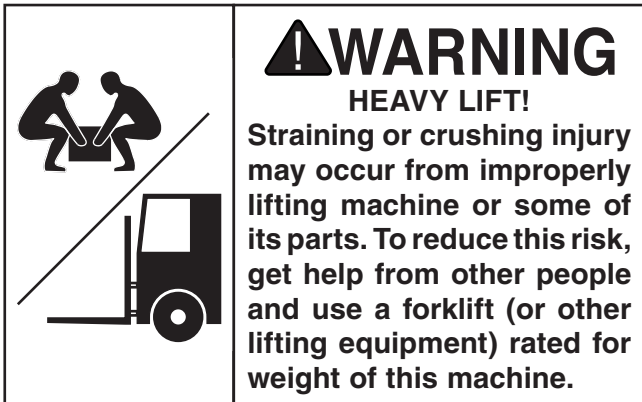

To move your boring machine:

1. Prepare the permanent location for the boring machine. Refer to **Power Supply**, on **Page 9**, and **Site Considerations** on **Page 14** for requirements.
2. Unbolt the machine from the shipping crate.
3. Use assistants and safe lifting methods to move the machine to its prepared location.
4. Make sure the top of the cabinet is level and mount the machine to the floor.

—If you are using permanent fasteners, use shims between the base and the floor to make sure the machine is level.

Note: To avoid cracking or warping the cast iron base, tighten the four corners down evenly.

—If you are using machine feet, adjust these until the machine is level.

Assembly

The machine must be fully assembled before it can be operated. Before beginning the assembly process, refer to **Needed for Setup** and gather all listed items. To ensure the assembly process goes smoothly, first clean any parts that are covered or coated in heavy-duty rust preventative (if applicable).

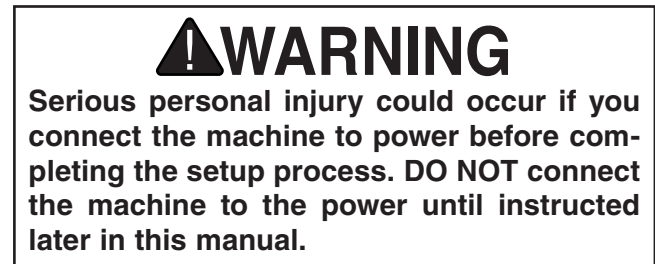

To assemble your machine:

1. Insert the fence extension rod assemblies half way into the fence extension, and use a 4mm hex wrench to tighten the cap screws (see **Figure 13**).

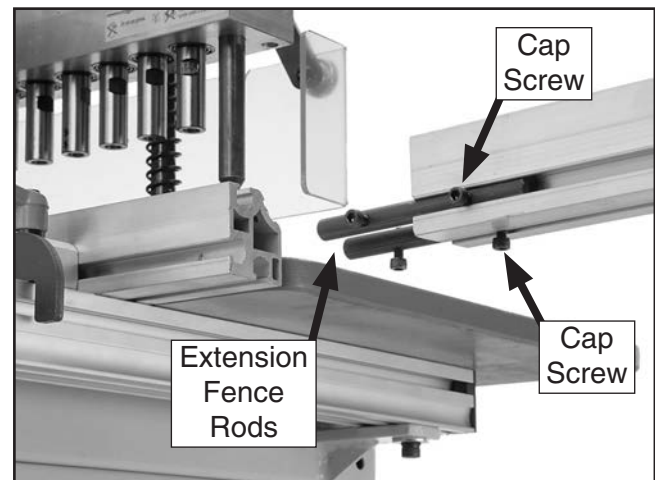

Figure 13. Extension fence rods and cap screws (shown from right rear of table).



- Slide the extension fence rods into the main longitudinal fence, and tighten the cap screws to hold the extension fence in place (see **Figure 14**).

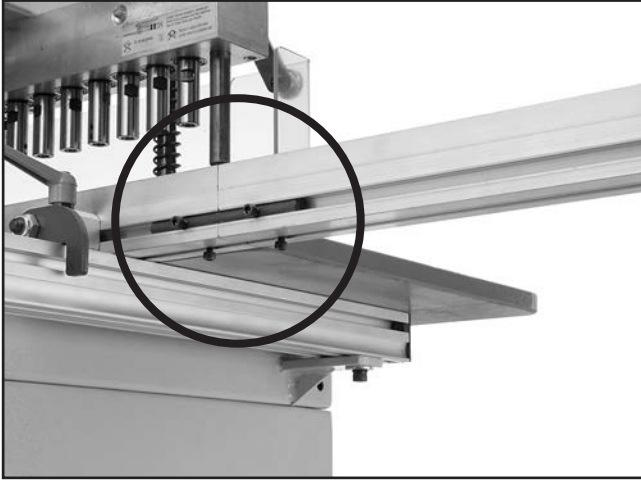

Figure 14. Extension fence installed.

- Clean any debris off the shafts of the indexing pins, and apply a thin film of light machine oil to the entire length.
- Slide the indexing pins with springs into the holes at the ends of the boring head assembly, as shown in **Figure 15**.

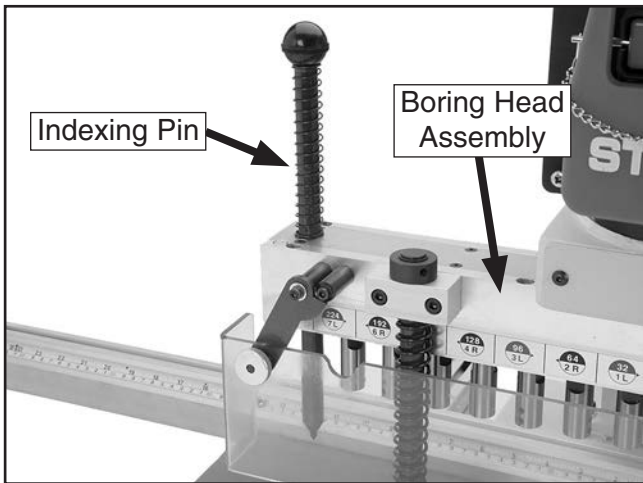

Figure 15. Indexing pin mounted in the boring head assembly.

Test Run

Once assembly is complete, test run the machine to ensure it is properly connected to power and safety components are functioning correctly.

If you find an unusual problem during the test run, immediately stop the machine, disconnect it from power, and fix the problem **BEFORE** operating the machine again. The **Troubleshooting** table in the **SERVICE** section of this manual can help.

The Test Run consists of verifying the following:

- The motor powers up and runs correctly, and
- the safety disabling mechanism on the switch works correctly.

!WARNING

Serious injury or death can result from using this machine BEFORE understanding its controls and related safety information. DO NOT operate, or allow others to operate, machine until the information is understood.

!WARNING

DO NOT start machine until all preceding setup instructions have been performed. Operating an improperly set up machine may result in malfunction or unexpected results that can lead to serious injury, death, or machine/property damage.

To test run the machine:

- Make sure all tools and objects used during set up are cleared away from the machine.
- If there are boring bits installed in the machine, remove them.
- Make sure the boring head guard is in place and is free to move up as the boring head assembly comes down.
- Connect the machine to the power source.



5. Verify that the machine is operating correctly by turning the machine **ON**.

- When operating correctly, the machine runs smoothly with little or no vibration or rubbing noises.

- Investigate and correct strange or unusual noises or vibrations before operating the machine further. Always disconnect the machine from power when investigating or correcting potential problems.

6. Turn the machine **OFF**.

7. Insert the switch disabling pin through the green ON button, as shown in **Figure 16**.

8. Press the green ON button to test the disabling feature on the switch.

- If the machine does *not* start, the switch disabling feature is working as designed.

- If the machine starts, immediately stop the machine. The switch disabling feature is not working correctly. This safety feature must work properly before proceeding with regular operations. Call Tech Support for help.



Figure 16. Switch disabling pin installed.



SECTION 4: OPERATIONS

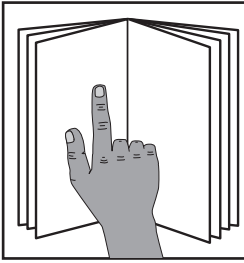

!WARNING

To reduce the risk of serious injury when using this machine, read and understand this entire manual before operating.

!WARNING

Damage to your eyes and lungs could result from using this machine without proper protective gear. Always wear safety glasses and a respirator when operating this machine.

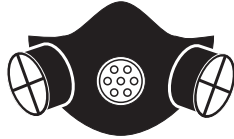

NOTICE

If you have never used this type of machine or equipment before, WE STRONGLY RECOMMEND that you read books, review industry trade magazines, or get formal training before beginning any projects. Regardless of the content in this section, Grizzly Industrial will not be held liable for accidents caused by lack of training.

Disabling & Locking Switch

The switch can be disabled and locked by inserting a padlock through the ON/START button, as shown. Locking the switch in this manner can prevent unauthorized operation of the machine, which is especially important if the machine is not stored inside an access-restricted building.

IMPORTANT: Locking the switch with a padlock only restricts its function. It is not a substitute for disconnecting power from the machine when adjusting or servicing.

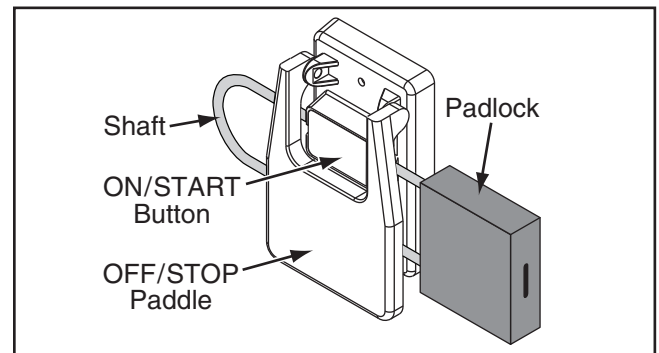

Figure 17. Switch disabled by a padlock.

!WARNING

Children or untrained people can be seriously injured by this machine. This risk increases with unsupervised operation. To help prevent unsupervised operation, disable and lock the switch before leaving machine unattended! Place key in a well-hidden or secure location.



Installing Boring Bits

The Model G0642 boring machine accepts boring bits with the following specifications:

Total Quantity 15
 Total Left Rotating 8
 Total Right Rotating 7
 Shank Diameter 10mm

The boring bits have a flat surface on the shank (see **Figure 18**), and an adjusting screw inside for height alignment.

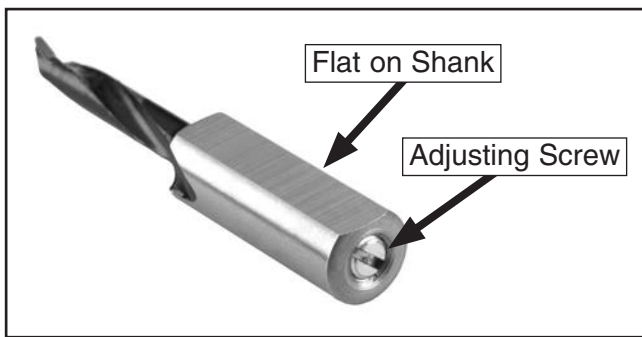

Figure 18. Standard boring bit.

⚠ CAUTION

Boring bits are sharp and can cut your hands. Protect your hands when removing or installing the bits.

To install boring bits:

1. DISCONNECT MACHINE FROM POWER!
2. Unscrew the two knurled knobs and remove the front see-through guard from the boring head assembly.

Note: Make sure the boring bits to be installed match the rotation direction of the chucks, as shown in the information circle above the chuck on the boring head assembly.

For example, in **Figure 19**, the center chuck will rotate to the right, as viewed from above the chuck. This is shown by the letter "R" in the information circle. The boring bit will also be 64mm on center from the middle or number "0" boring bit, as shown by the number in the top of the information circle.

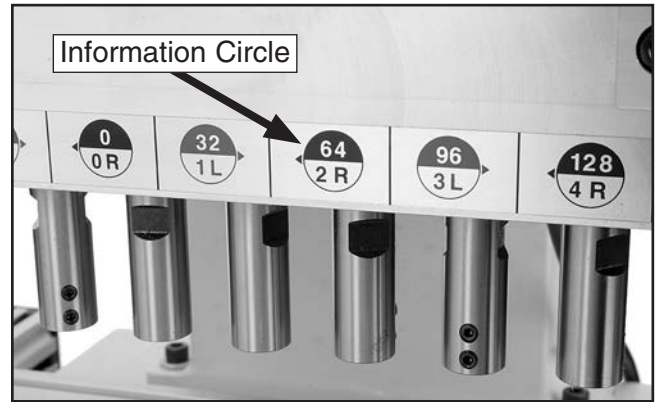

Figure 19. Boring chuck information circle on boring head assembly.

3. Align the flat surface of the bit shank with the chuck set screws and insert the bit completely into the chuck.
4. Use a 2.5mm hex wrench to firmly tighten two M5-.8 x 5mm set screws (see **Figure 20**) against the flat shank of the boring bit.

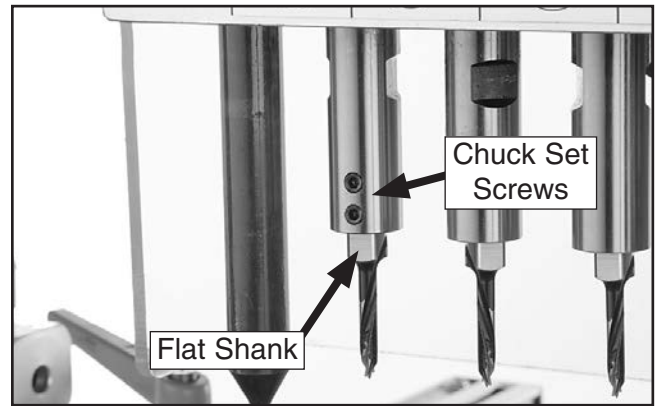

Figure 20. Boring bit installed.

5. Repeat **Steps 3–4** with the rest of the bits to be installed, making sure the bit direction matches that of the chuck.
6. Re-install the boring head guard.

Note: Generally, slight differences of drilling depth from one bit to another is acceptable. However, if the drilling depth across all boring bits is required, see **Aligning Boring Bit Height** on **Page 30**.



Adjusting Drilling Depth

The drilling depth is precisely adjusted by using the depth control on top of the headstock column (see **Figure 21**). The depth control window shows the drilling depth in inches, with the last two digits as decimals.

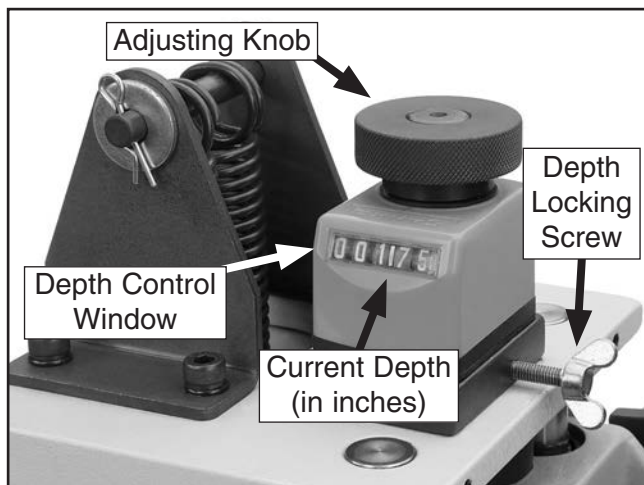

Figure 21. Boring bit depth control.

To adjust the drilling depth of the boring bits:

1. Loosen the depth locking screw shown in **Figure 21**.
2. Use the adjusting knob to bring the depth control to "0".
3. Calculate the drilling depth by using the following formula:

A + B = Drilling Depth

A = The distance from the bottom of the boring bit to the workpiece.

B = The desired depth of the hole to be drilled.

Note: Use the following case and **Figure 22** for an example of calculating drilling depth.

In this example, the distance from the bottom of the boring bit to the workpiece is $2\frac{1}{4}$ " (**A**), and the depth of the desired hole in the workpiece is $\frac{1}{2}$ " (**B**). Thus, the drilling depth is $2\frac{3}{4}$ ".

Calculation: $2\frac{1}{4}" + \frac{1}{2}" = 2\frac{3}{4}"$

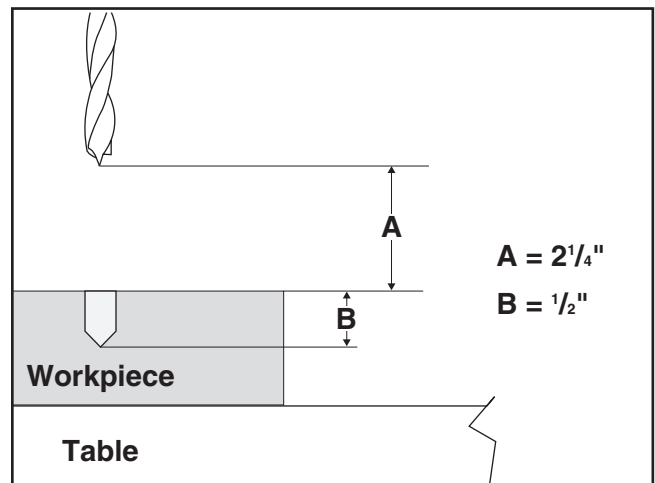

Figure 22. Example of calculating drilling depth.

4. Convert any fraction of the calculated drilling depth to a 2-place decimal ($\frac{3}{4}$ " in the above example is converted to 0.75").
5. Set the depth control to the calculated drilling depth and re-tighten the depth locking screw to secure the setting.

Note: In the above example, the depth control would be set so that 2.75 would show in the depth control window.

6. Test the drilling depth setting on a scrap piece of stock that is the same thickness as your workpiece. Fine tune the depth control setting until you are satisfied with the drilling depth.

NOTICE

This line boring machine is designed to drill only wood products. Drilling any other material may damage the machine and will void the warranty.



Adjusting Hold-down Height

The hold-downs must firmly hold the workpiece during the boring operation. They are adjustable to accommodate the thickness of your stock.

To adjust the height of the workpiece hold-downs:

1. DISCONNECT THE BORING MACHINE FROM POWER!
2. Loosen the lock collar set screw so that the collar moves freely on the hold-down shaft (see **Figure 23**).

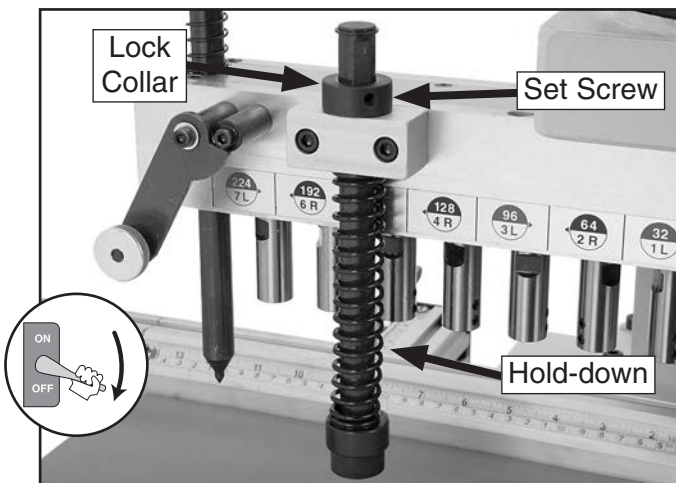

Figure 23. Workpiece hold-down (boring head guard removed for photo clarity).

3. Lift the hold-down up until the bottom is just slightly higher than your workpiece when the boring head assembly is in the upper position, then re-tighten the locking collar set screw to secure the setting.

NOTICE

Make sure the hold-downs exert enough pressure to keep the workpiece in place against the rotational force of the boring bits. Otherwise, the workpiece may move during the boring operation, resulting in a drilling line that is out of alignment.

Positioning the Workpiece

The workpiece is positioned along the longitudinal and cross paths to align the boring bits with the desired line of drilling.

To position the workpiece for drilling:

1. Turn the machine **OFF**.
2. Unlock the longitudinal fence and move it along the cross fences to reach the correct distance from the boring bits along its entire length, then use the locking levers to secure it in place.

Note: The distance from the longitudinal fence to the boring bit centers can be measured on the cross fence scale, as shown in **Figure 24**.



Figure 24. Distance of 4" of the longitudinal fence from boring bit centers, as read on the cross fence scale.

NOTICE

If both ends of the longitudinal fence are not the same distance from the boring bit centers, the drilled holes will not line up correctly. Make sure that both ends of the longitudinal fence are the same distance from the boring bit centers before you tighten the locking levers.



- Determine the drilling starting point of your workpiece, then position it under the boring head assembly and firmly against the longitudinal fence.
- Use the longitudinal fence stops (**Figure 25**) to preserve the starting point when drilling workpieces that are the same length.

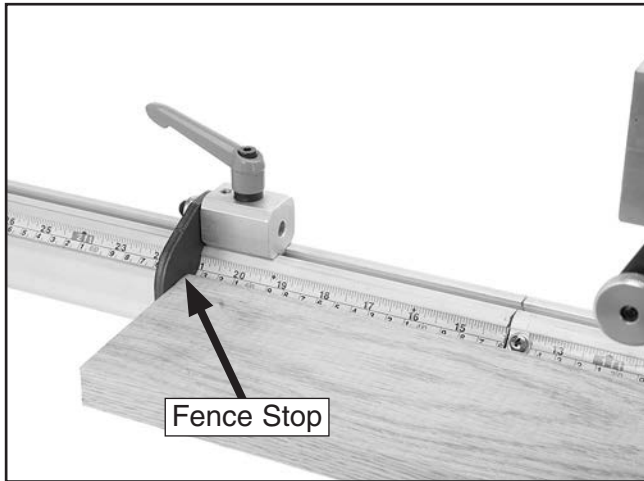

Figure 25. Longitudinal fence stop.

- If you need to drill more than 15 holes, push the indexing pin into the last previously drilled hole to position the workpiece, as shown in **Figure 26**.

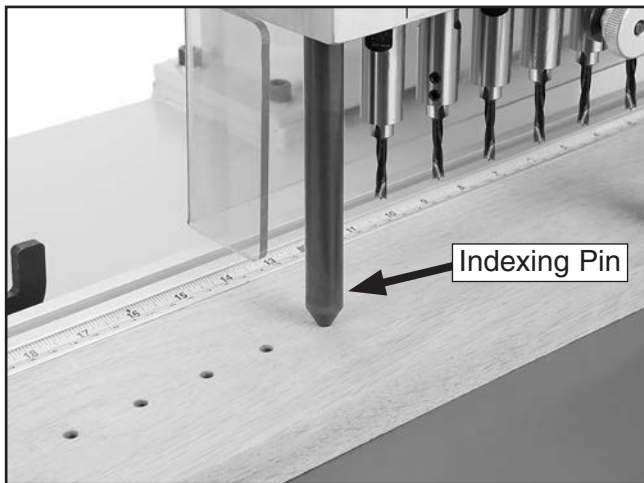

Figure 26. Using the indexing pin to position workpiece for additional drilling (boring head guard removed for photo clarity).

Drilling Overview

Before beginning the boring operation, take these precautions:

- Make sure the boring head guard is in place and is free to move up as the boring head assembly comes down.
- Lock the table in the correct position.
- Set the depth control to the calculated drilling depth.
- Make sure that your workpiece is firmly against the longitudinal fence, and use push sticks to hold it in position.

When ready, use the downfeed handle to lower the boring head assembly in a controlled manner. The rate that you move the boring bits into the workpiece is determined by the workpiece material and your experience, and will affect the quality of the operation.

After the drilling is complete, raise the downfeed handle so that the boring head assembly is in the uppermost position, and turn the machine **OFF**.

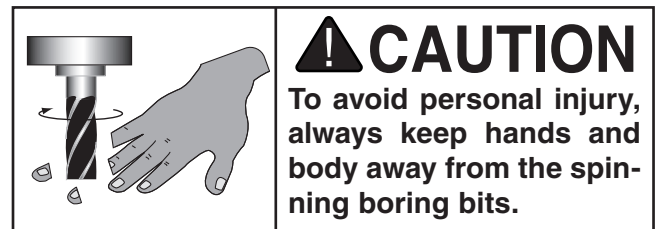

SECTION 5: ACCESSORIES

⚠️ WARNING

Installing unapproved accessories may cause machine to malfunction, resulting in serious personal injury or machine damage. To reduce this risk, only install accessories recommended for this machine by Grizzly.

NOTICE

Refer to our website or latest catalog for additional recommended accessories.

- G5562—SLIPIT® 1 Qt. Gel
- G5563—SLIPIT® 12 Oz. Spray
- G2871—Boeshield® T-9 12 Oz. Spray
- G2870—Boeshield® T-9 4 Oz. Spray
- H3788—G96® Gun Treatment 12 Oz. Spray
- H3789—G96® Gun Treatment 4.5 Oz. Spray



Figure 27. Recommended products for protecting unpainted cast iron/steel part on machinery.

T28172—14" x 39" Heavy-Duty Roller Table
 T28369—14" x 78" Heavy-Duty Roller Table
 T28370—14" x 118" Heavy-Duty Roller Table
 Increase material handling and processing efficiency with one or more of these Heavy-Duty Roller Tables. Ideal for easily positioning material for cross cutting or cutting to length using a chop saw or metal cutting bandsaw. Simply place a roller table on one or both sides of your saw and production time is automatically improved!



Figure 28. G8982 Shop Fox roller table.

H3361—Clear Shelf Supports

H3362—White Shelf Supports

These Shelf Supports are ideal for easy to adjust shelving. Available in clear and white. Pins measure $1\frac{3}{64}$ " (5mm) diameter by $\frac{5}{16}$ " long. 12 per pack.



Figure 29. Shelf Supports.

order online at www.grizzly.com or call 1-800-523-4777



T20546—5mm Left Bit for Line Boring Machine
T20547—5mm Right Bit for Line Boring Machine

These 5mm Bits are for the G0642 & G0643 Line Boring Machines. Sold as singles.

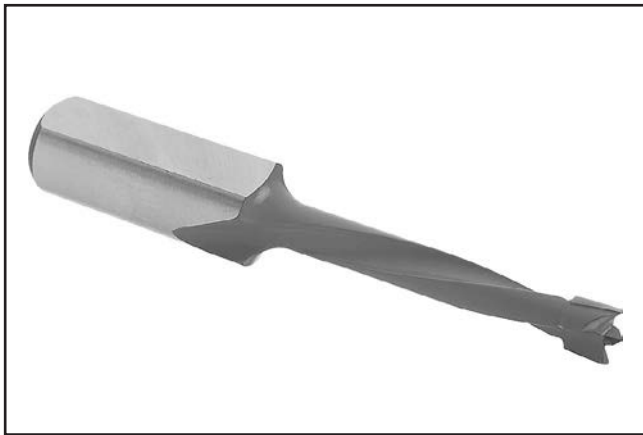

Figure 30. T20546 Bit.

T20548—Bit Set for G0642 Boring Machine

These bits in the 15-pc. Boring Bit Set for G0642 Boring Machine are 10mm flat shank.

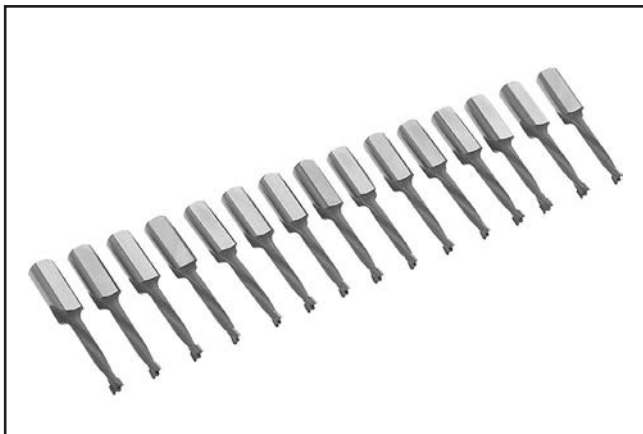

Figure 31. T20548 Bit Set.

H2499—Small Half-Mask Respirator
H3631—Medium Half-Mask Respirator
H3632—Large Half-Mask Respirator
H3635—Cartridge Filter Pair P100

Wood dust has been linked to nasal cancer and severe respiratory illnesses. If you work around-dust everyday, a half-mask respirator can be a lifesaver. Also compatible with safety glasses!



Figure 32. Half-mask respirator with disposable cartridge filters.

Basic Eye Protection

- T20501—Face Shield Crown Protector 4"
- T20502—Face Shield Crown Protector 7"
- T20503—Face Shield Window
- T20451—"Kirova" Clear Safety Glasses
- T20452—"Kirova" Anti-Reflective S. Glasses
- T20456—DAKURA Safety Glasses, Black/Clear

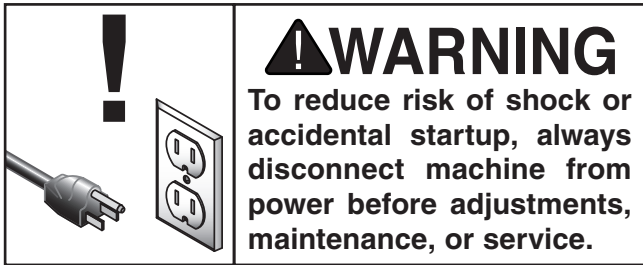

Figure 33. Assortment of basic eye protection.

order online at www.grizzly.com or call 1-800-523-4777



SECTION 6: MAINTENANCE



Schedule

For optimum performance from this machine, this maintenance schedule must be strictly followed.

Ongoing

To maintain a low risk of injury and proper machine operation, if you ever observe any of the items below, shut down the machine immediately and fix the problem before continuing operations:

- Loose mounting bolts.
- Worn or damaged wires.
- Worn or damaged boring bits.
- Any other unsafe condition.

Weekly Maintenance

- Clean and lubricate headstock ways and leadscrew.
- Clean/grease hold down shaft.

Monthly Check

- Lubricate boring head assembly.
- Clean/vacuum dust buildup off motor.

Cleaning

Vacuum excess wood chips and sawdust, and wipe off the remaining dust with a dry cloth. If any resin has built up, use a resin dissolving cleaner to remove it. Treat all unpainted steel with a non-staining lubricant after cleaning.

Lubrication

It is essential to clean components before lubricating them because dust and chips build up on lubricated components and make them hard to move. Simply adding more lubricant to them will not yield smooth moving components.

Lubricate Boring Head Assembly

Use a grease gun to inject two pumps of multi-purpose grease into each of the two grease fittings, located on either end of the boring head rear face (see **Figure 34**).

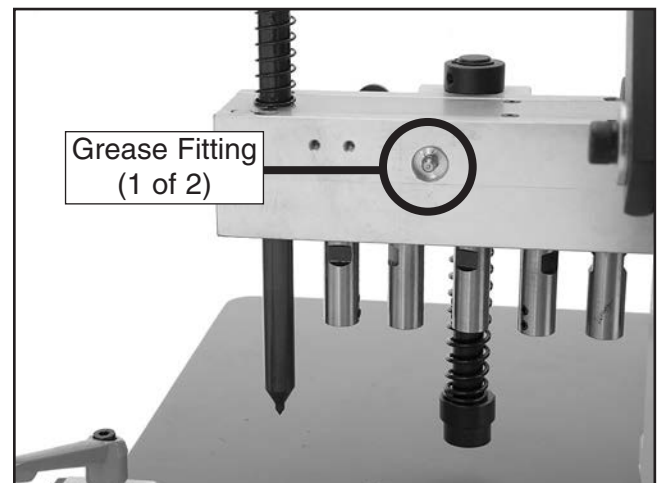
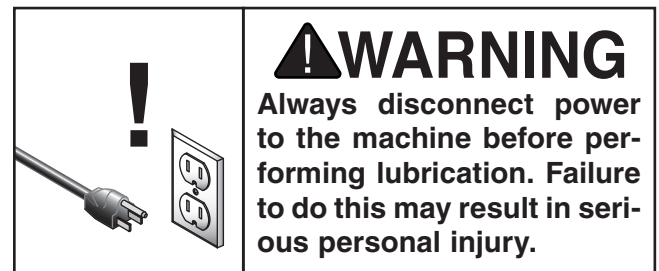

Figure 34. Boring head assembly grease fitting (1 of 2 shown).



Lubricate Headstock Slide Shafts and Leadscrew

1. DISCONNECT THE BORING MACHINE FROM POWER!
2. Set the depth control to "0".
3. Clean sawdust and debris from the visible sections of the headstock slide shafts and leadscrew (see **Figure 35**).

Note: *There is one headstock slide shaft on both sides of the column.*

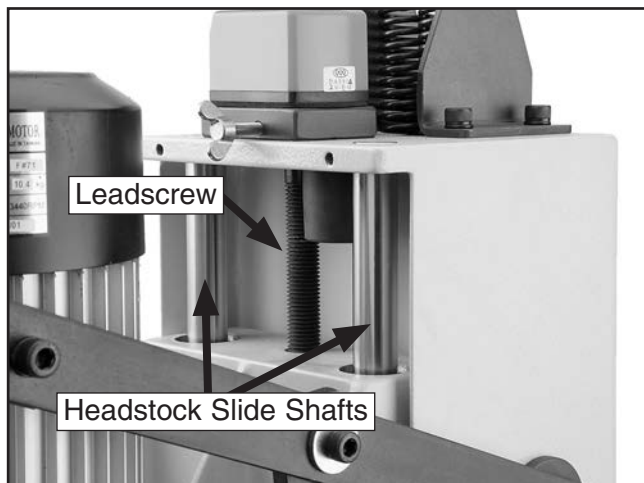

Figure 35. Headstock slide shafts and leadscrew.

NOTICE

Failure to perform proper lubrication maintenance on this machine will lead to premature wear of the moving parts, and will void the warranty.

4. Apply a thin coat of light machine oil to the slide shafts and leadscrew.
5. With the power still disconnected, use the downfeed handle to move the boring head assembly through the entire range of motion to evenly distribute the lubrication.



SECTION 7: SERVICE

Review the troubleshooting and procedures in this section if a problem develops with your machine. If you need replacement parts or additional help with a procedure, call our Technical Support. **Note:** *Please gather the serial number and manufacture date of your machine before calling.*

Troubleshooting

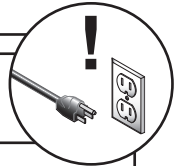

Motor & Electrical

Symptom	Possible Cause	Possible Solution
Machine does not start or a breaker trips.	<ol style="list-style-type: none"> 1. Plug/receptacle is at fault or wired incorrectly. 2. Start capacitor is at fault. 3. Motor connection wired incorrectly. 4. Wall fuse/circuit breaker is blown/tripped. 5. Power supply switched OFF or is at fault. 6. Wiring is open/has high resistance. 7. Power ON/OFF switch is at fault. 8. Centrifugal switch is at fault. 9. Motor is at fault. 	<ol style="list-style-type: none"> 1. Test for good contacts; correct the wiring. 2. Test/replace if faulty. 3. Correct motor wiring connections. 4. Ensure circuit size is suitable for this machine; replace weak breaker. 5. Ensure power supply is switched on; ensure power supply has the correct voltage. 6. Check for broken wires or disconnected/corroded connections, and repair/replace as necessary. 7. Replace faulty ON/OFF switch. 8. Adjust/replace the centrifugal switch if available. 9. Test/repair/replace.
Machine has vibration or noisy operation.	<ol style="list-style-type: none"> 1. Motor or component is loose. 2. Motor mount loose/broken. 3. Machine is incorrectly mounted or sits unevenly on floor. 4. Motor fan is rubbing on fan cover. 5. Motor/boring head bearings are at fault. 6. Centrifugal switch is faulty. 7. Chuck or boring bit is at fault. 	<ol style="list-style-type: none"> 1. Inspect/replace stripped or damaged bolts/nuts, and re-tighten with thread locking fluid. 2. Tighten/replace. 3. Tighten/replace anchor studs in floor; relocate/shim machine. 4. Replace dented fan cover; replace loose/damaged fan. 5. Test by rotating shaft; rotational grinding/loose shaft requires bearing replacement. 6. Replace. 7. Replace out-of-round chuck, dull, or bent boring bit.
Machine stalls or is overloaded.	<ol style="list-style-type: none"> 1. Workpiece material is not suitable for this machine. 2. Run capacitor is at fault. 3. Motor connection is wired incorrectly. 4. Plug/receptacle is at fault. 5. Motor/boring head bearings are at fault. 6. Machine undersized for task. 7. Motor has overheated. 8. Motor is at fault. 9. Centrifugal switch is at fault. 	<ol style="list-style-type: none"> 1. Only drill wood products; make sure moisture content is below 20% and there are no foreign materials in the workpiece. 2. Test/repair/replace. 3. Correct motor wiring connections. 4. Test for good contacts; correct the wiring. 5. Test by rotating shaft; rotational grinding/loose shaft requires bearing replacement. 6. Use sharp bits/reduce downfeed rate. 7. Clean off motor, let cool, and reduce workload. 8. Test/repair/replace. 9. Adjust/replace centrifugal switch if available.



Operation

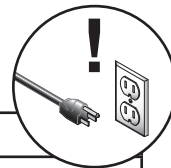

Symptom	Possible Cause	Possible Solution
Machine slows when operating.	<ol style="list-style-type: none"> 1. Applying too much pressure to workpiece. 2. Boring bits are dull. 	<ol style="list-style-type: none"> 1. Reduce the downfeed rate. 2. Replace boring bits.
Holes do not line up correctly.	<ol style="list-style-type: none"> 1. Longitudinal fence is not parallel with the boring head. 2. Workpiece not kept firmly against longitudinal fence. 	<ol style="list-style-type: none"> 1. Make sure that both ends of the longitudinal fence are the same distance from the boring head/bit centers before tightening the locking levers. 2. Use push sticks to keep workpiece firmly against longitudinal fence during drilling operation.
Holes bored at an angle.	<ol style="list-style-type: none"> 1. Table is not parallel with boring head. 2. Chuck or boring bit is at fault. 	<ol style="list-style-type: none"> 1. Align table parallel to boring head (see Page 32). 2. Replace out-of-round chuck; replace/re-install boring bit.
Depth of holes are not equal.	<ol style="list-style-type: none"> 1. Table is not parallel with boring head. 2. Heights of boring bits are not aligned. 	<ol style="list-style-type: none"> 1. Align table parallel to boring head (see Page 32). 2. Align the height of boring bits (see Page 33).



Adjusting Table Parallel to Boring Head

If the table is not parallel to the boring head, drilled holes will be at an angle or at different depths.

To check and adjust the table parallel to the boring head:

1. DISCONNECT THE BORING MACHINE FROM POWER!
2. Use a dial indicator or a planed piece of stock to measure the distance between the table and boring head at the four corners of the boring head (refer to the X's illustrated in **Figure 36**).

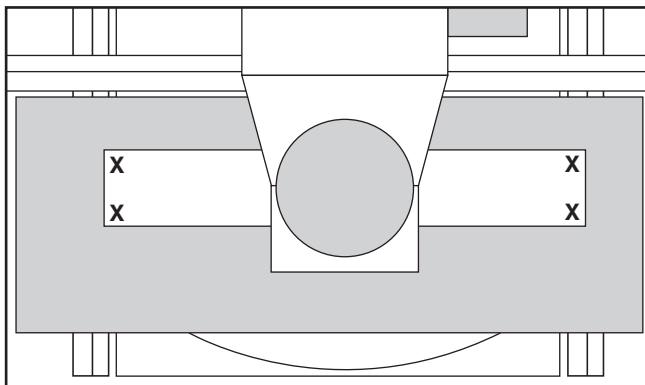

Figure 36. Measurement points (X's) for table and boring head parallelism (top view).

—If these distances are not equal, the table and boring head are not parallel to one another. Continue to **Step 3**.

—If these distances are equal, the table and boring head are parallel, and no further adjustments are necessary.

3. Loosen the cap screws that secure the cross fence (see **Figure 37**), and shim between the mounting bracket and the cross fence.

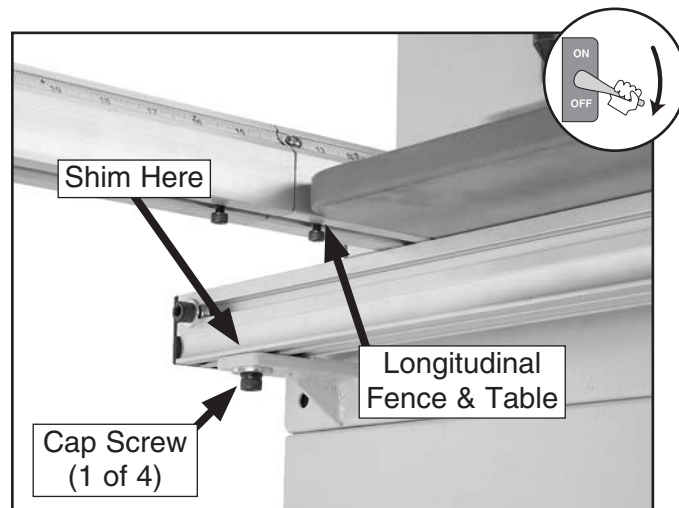

Figure 37. Adjusting table parallelism.

4. Re-tighten the cross fence cap screws, and re-check the parallelism of the table and boring head. Repeat this procedure if necessary.



Aligning Boring Bit Height

To ensure drilled holes are consistent in depth along the length of the workpiece, the height of all boring bits must be equal.

Note: *The table must be parallel to the boring head assembly before aligning the boring bits. Refer to **Adjusting Table Parallel to Boring Head** on **Page 32**.*

To align boring bit height:

1. DISCONNECT THE BORING MACHINE FROM POWER!

CAUTION

Boring bits are sharp and can cut your hands. Protect yourself by using a shop rag to handle the bits during removal or installation.

2. Make sure that all boring bits are inserted fully into the chuck.

Note: *This can be done by loosening the two set screws that hold the bit into the chuck, and, while applying moderate upward pressure on the bit, re-tightening the set screws.*

3. Use a dial indicator or planed piece of stock and feeler gauges to determine if all boring bits are the same distance from the table.
4. The height of a boring bit can be adjusted by removing the bit from the chuck, turning the center screw of the bit (see **Figure 38**), then re-installing the bit into the chuck.

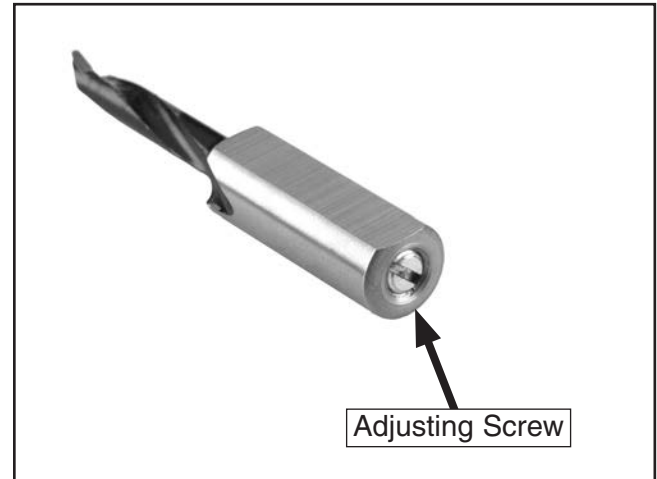

Figure 38. Boring bit height adjusting screw.

Note: *Threading the adjusting screw into the bit raises the working height of the boring bit.*



Model G0642 Motor & ON/OFF Switch Wiring Diagram

COLOR KEY	
Black	
White	
Green	
Red	



Figure 39. Motor wiring.

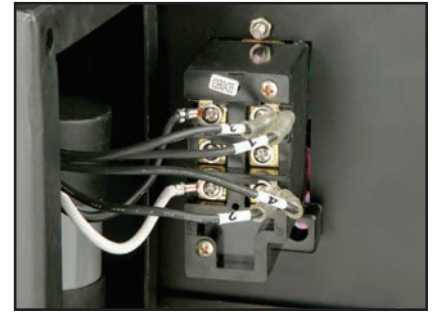
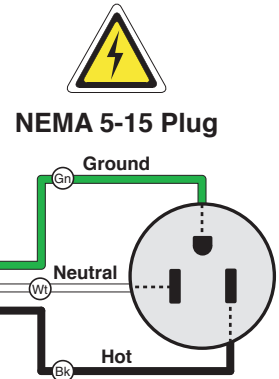
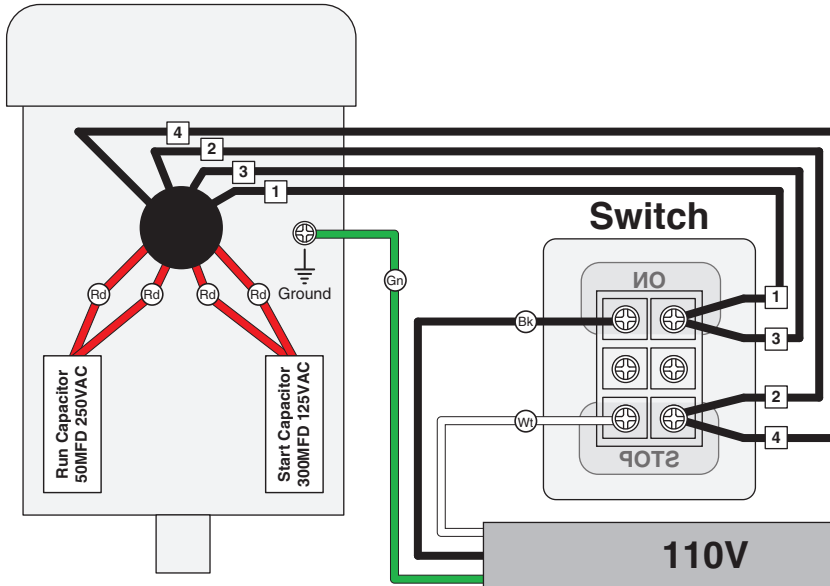
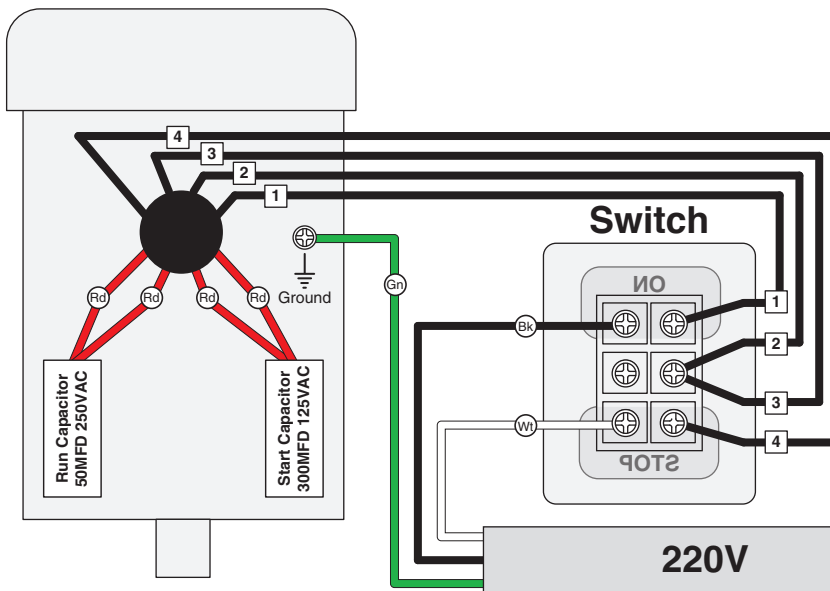

Figure 40. Switch wiring (110V).

Motor Wired for 110V (Pre-Wired)



Motor Wired for 220V



NOTICE

The motor wiring shown here is current at the time of printing, but it may not match your machine. Always use the wiring diagram inside the motor junction box.

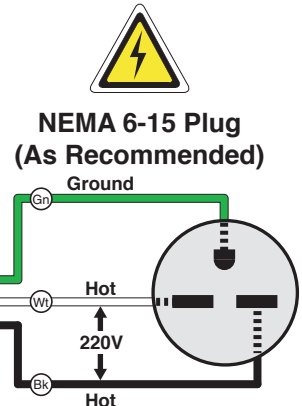

SECTION 8: PARTS

We do our best to stock replacement parts when possible, but we cannot guarantee that all parts shown are available for purchase. Call (800) 523-4777 or visit www.grizzly.com/parts to check for availability.

Column & Electrical

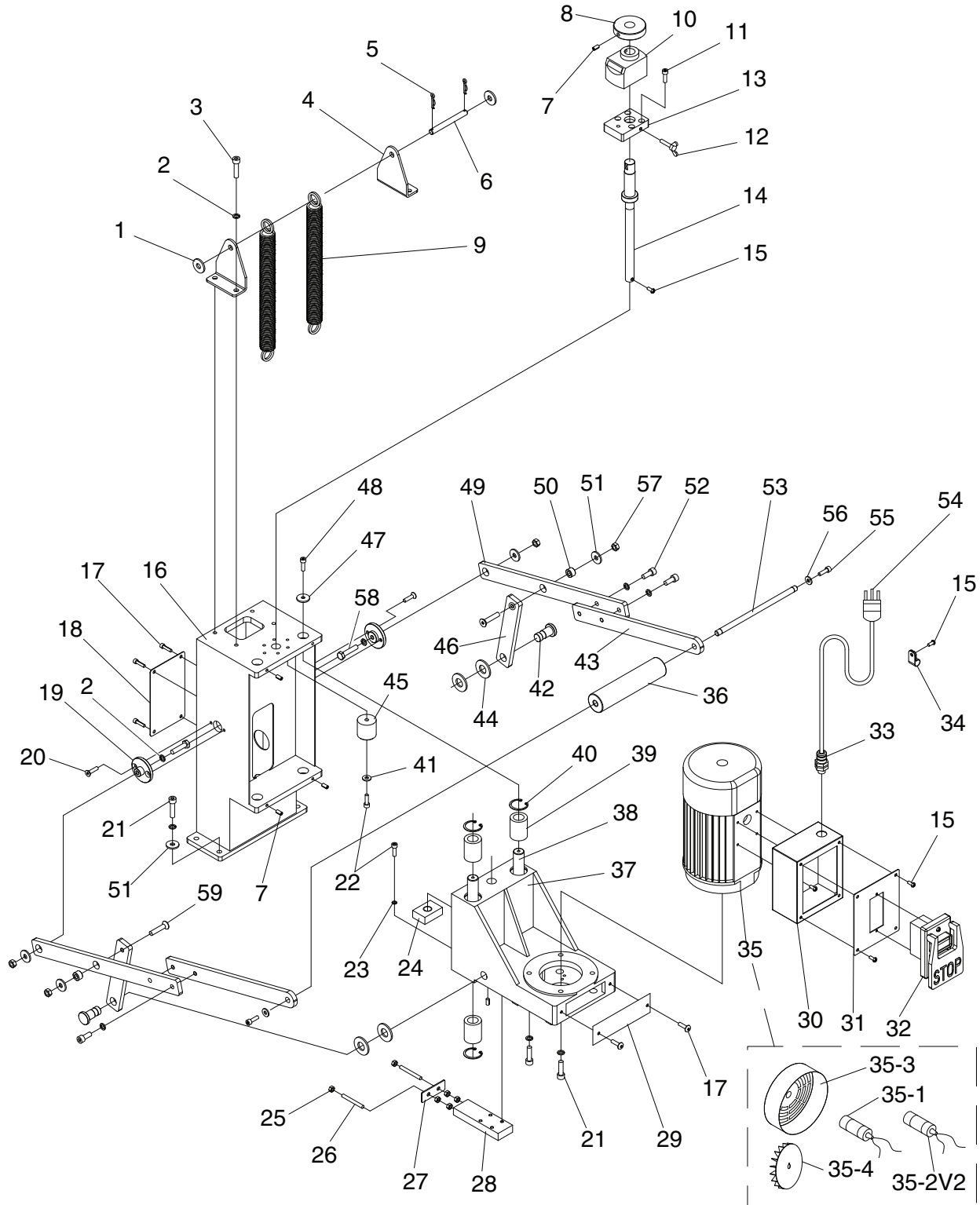

Column & Electrical Parts List

REF	PART #	DESCRIPTION
1	P0642001	FLAT WASHER 10MM
2	P0642002	LOCK WASHER 8MM
3	P0642003	CAP SCREW M8-1.25 X 16
4	P0642004	HEADSTOCK SPRING BRACKET
5	P0642005	HAIRPIN COTTER PIN
6	P0642006	DRILLED HEADLESS CLEVIS PIN
7	P0642007	SET SCREW M6-1 X 10
8	P0642008	KNURLED KNOB
9	P0642009	HEADSTOCK EXTENSION SPRING
10	P0642010	DEPTH CONTROL GAUGE
11	P0642011	CAP SCREW M6-1 X 20
12	P0642012	WING SCREW M6-1 X 25
13	P0642013	DEPTH CONTROL GAUGE MOUNT
14	P0642014	DEPTH CONTROL ROD
15	P0642015	PHLP HD SCR M5-.8 X 12
16	P0642016	COLUMN
17	P0642017	CAP SCREW M5-.8 X 10
18	P0642018	COVER
19	P0642019	PIVOT BRACKET
20	P0642020	FLAT HD SCR M6-1 X 12
21	P0642021	CAP SCREW M8-1.25 X 25
22	P0642022	CAP SCREW M6-1 X 30
23	P0642023	LOCK WASHER 6MM
24	P0642024	THREADED BLOCK
25	P0642025	HEX NUT M6-1
26	P0642026	SET SCREW M6-1 X 45
27	P0642027	SPACER
28	P0642028	MOUNT
29	P0642029	COVER
30	P0642030	SWITCH BOX
31	P0642031	SWITCH PANEL
32	P0642032	ON/OFF SWITCH

REF	PART #	DESCRIPTION
33	P0642033	STRAIN RELIEF
34	P0642034	CABLE CLAMP
35	P0642035	MOTOR 1HP 110/220V 1PH
35-1	P0642035-1	S CAPACITOR 300M 125V 1.38 X 3.38
35-2V2	P0642035-2V2	R CAPACITOR 50M 250V 2-1/4 X 1-1/2 V2.11.14
35-3	P0642035-3	MOTOR FAN COVER
35-4	P0642035-4	MOTOR FAN
36	P0642036	HANDLE
37	P0642037	HEADSTOCK
38	P0642038	HEADSTOCK WAY
39	P0642039	BUSHING
40	P0642040	INT RETAINING RING 32MM
41	P0642041	FLAT WASHER 6MM
42	P0642042	PIVOT PIN
43	P0642043	FRONT PIVOT BAR
44	P0642044	FLAT WASHER 16MM
45	P0642045	UPPER DEPTH STOP
46	P0642046	SMALL PIVOT BAR
47	P0642047	FLAT WASHER 6MM
48	P0642048	CAP SCREW M6-1 X 12
49	P0642049	REAR PIVOT BAR
50	P0642050	BUSHING
51	P0642051	FLAT WASHER 8MM
52	P0642052	CAP SCREW M8-1.25 X 20
53	P0642053	DRILLED HEADLESS CLEVIS PIN
54	P0642054	POWER CORD
55	P0642055	BUTTON HD CAP SCR M6-1 X 20
56	P0642056	FLAT WASHER 6MM
57	P0642057	LOCK NUT M6-1
58	P0642058	HEX BOLT M8-1.25 X 35
59	P0642059	FLAT HD SCR M8-1.25 X 35



Table

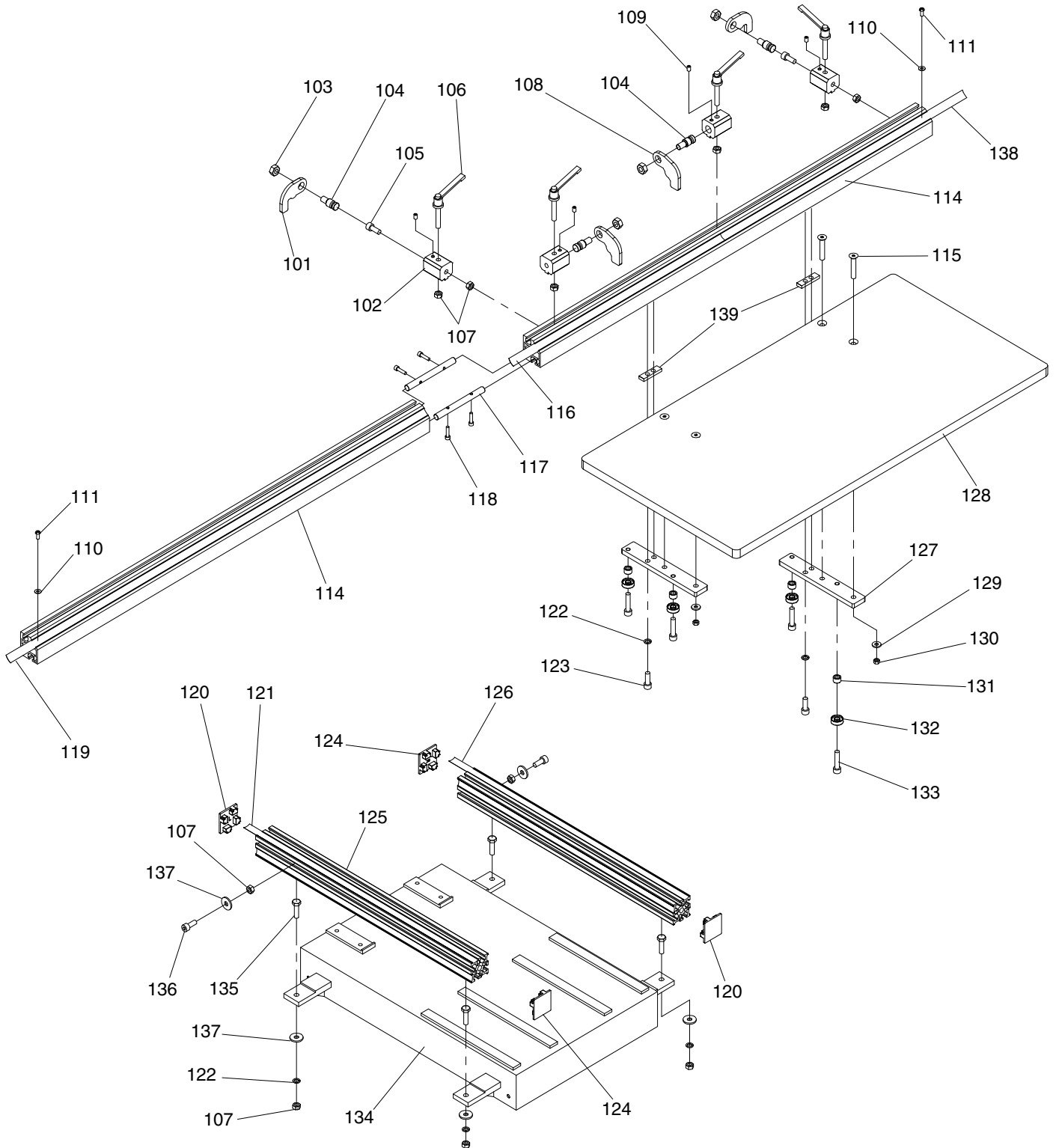

Table Parts List

REF	PART #	DESCRIPTION
101	P0642101	CROSS STOP PLATE
102	P0642102	MOUNTING BLOCK
103	P0642103	LOCK NUT M10-1.5
104	P0642104	STOP PIN
105	P0642105	CAP SCREW M8-1.25 X 16
106	P0642106	LOCK LEVER
107	P0642107	HEX NUT M8-1.25
108	P0642108	LONGITUDINAL STOP PLATE
109	P0642109	SET SCREW M6-1 X 6
110	P0642110	FLAT WASHER 5MM
111	P0642111	PHLP HD SCR M5-.8 X 12
114	P0642114	LONGITUDINAL FENCE
115	P0642115	FLAT HD SCR M6-1 X 40
116	P0642116	LEFT CENTER LONGITUDINAL SCALE
117	P0642117	FENCE CONNECTING ROD
118	P0642118	CAP SCREW M5-.8 X 16
119	P0642119	LEFT LONGITUDINAL SCALE
120	P0642120	LEFT CROSS FENCE END PLUG
121	P0642121	LEFT CROSS FENCE SCALE

REF	PART #	DESCRIPTION
122	P0642122	LOCK WASHER 8MM
123	P0642123	CAP SCREW M8-1.25 X 20
124	P0642124	RIGHT CROSS FENCE END PLUG
125	P0642125	CROSS FENCE
126	P0642126	RIGHT CROSS FENCE SCALE
127	P0642127	TABLE MOUNT
128	P0642128	TABLE
129	P0642129	FLAT WASHER 6MM
130	P0642130	HEX NUT M6-1
131	P0642131	BUSHING
132	P0642132	BALL BEARING 608 ZZ
133	P0642133	CAP SCREW M8-1.25 X 35
134	P0642134	CABINET TOP
135	P0642135	CAP SCREW M8-1.25 X 25
136	P0642136	CAP SCREW M8-1.25 X 12
137	P0642137	FLAT WASHER 8MM
138	P0642138	RIGHT CENTER LONGITUDINAL SCALE
139	P0642139	CONNECTING BAR



Cabinet & Tools

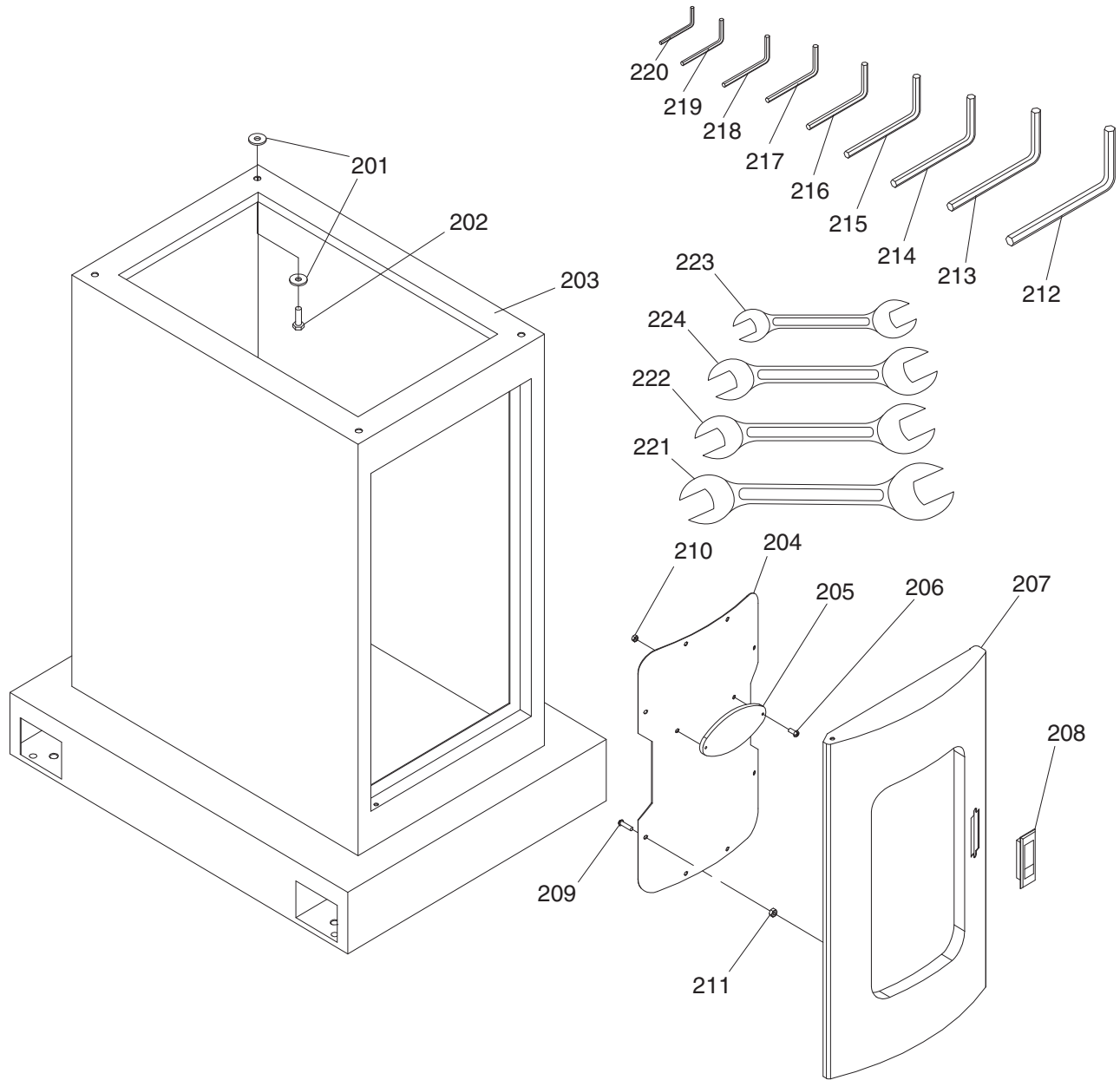

REF	PART #	DESCRIPTION
201	P0642201	FLAT WASHER 8MM
202	P0642202	HEX BOLT M8-1.25 X 16
203	P0642203	CABINET
204	P0642204	COVER
205	P0642205	GRIZZLY LOGO PLATE
206	P0642206	PHLP HD SCR M4-.7 X 12
207	P0642207	DOOR
208	P0642208	DOOR LATCH
209	P0642209	PHLP HD SCR M5-.8 X 12
210	P0642210	HEX NUT M4-.7
211	P0642211	HEX NUT M5-.8
212	P0642212	HEX WRENCH 10MM

REF	PART #	DESCRIPTION
213	P0642213	HEX WRENCH 8MM
214	P0642214	HEX WRENCH 6MM
215	P0642215	HEX WRENCH 5MM
216	P0642216	HEX WRENCH 4MM
217	P0642217	HEX WRENCH 3MM
218	P0642218	HEX WRENCH 2.5MM
219	P0642219	HEX WRENCH 2MM
220	P0642220	HEX WRENCH 1.5MM
221	P0642221	COMBO WRENCH 17/19MM
222	P0642222	COMBO WRENCH 12/14MM
223	P0642223	COMBO WRENCH 8/10MM
224	P0642224	COMBO WRENCH 11/13MM



Boring Head

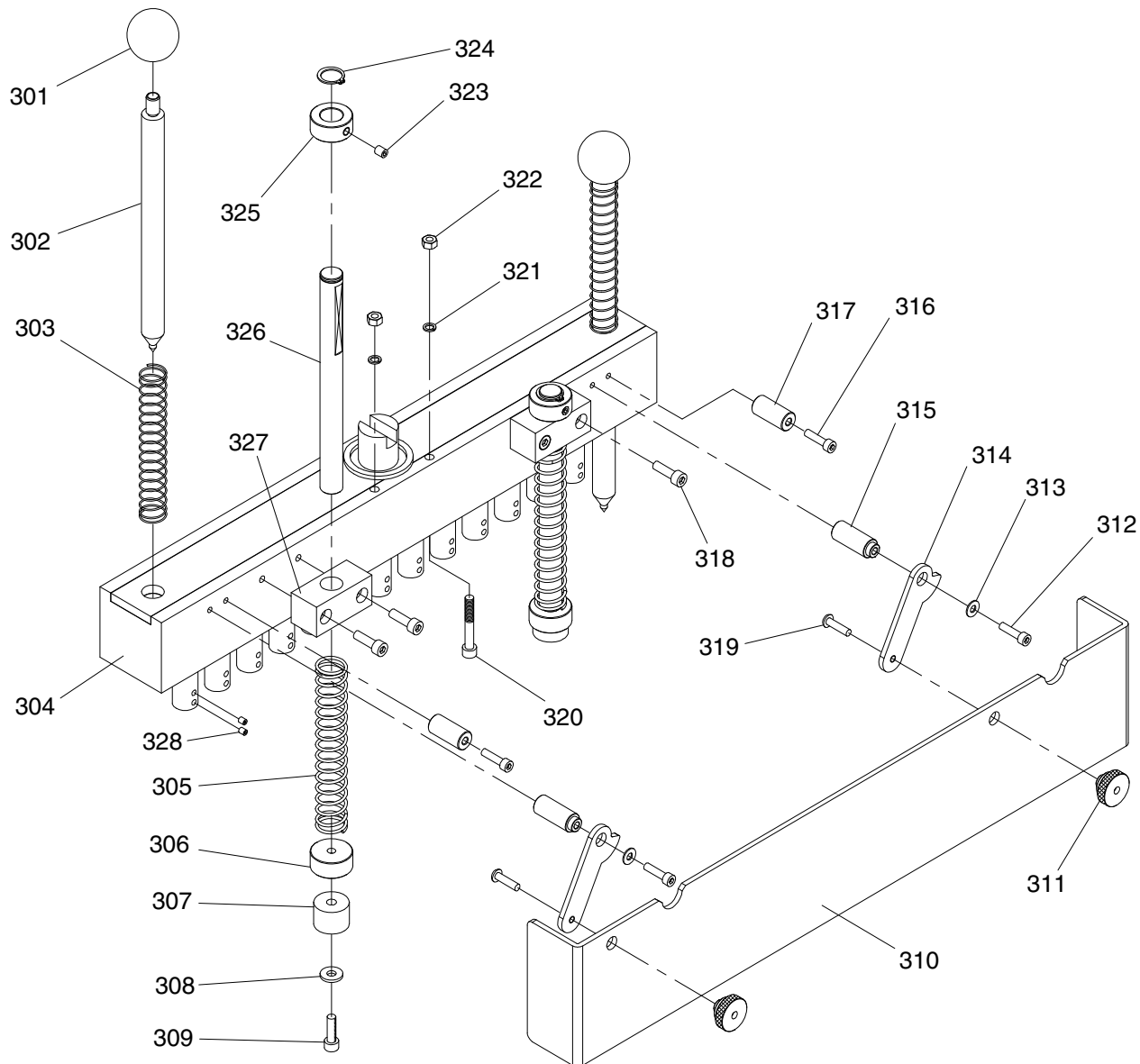

REF	PART #	DESCRIPTION
301	P0642301	INDEXING PIN KNOB
302	P0642302	INDEXING PIN
303	P0642303	INDEXING COMPRESSION SPRING
304	P0642304	BORING HEAD ASSY
305	P0642305	HOLD DOWN COMPRESSION SPRING
306	P0642306	COLLAR
307	P0642307	HOLD DOWN PAD
308	P0642308	FLAT WASHER 6MM
309	P0642309	CAP SCREW M6-1 X 20
310	P0642310	BORING HEAD GUARD
311	P0642311	GUARD RETAINER
312	P0642312	CAP SCREW M5-.8 X 30
313	P0642313	FLAT WASHER 5MM
314	P0642314	PIVOT BRACKET

REF	PART #	DESCRIPTION
315	P0642315	BUSHING
316	P0642316	CAP SCREW M5-.8 X 35
317	P0642317	BUSHING
318	P0642318	CAP SCREW M6-1 X 30
319	P0642319	BUTTON HD CAP SCR M5-.8 X 20
320	P0642320	CAP SCREW M6-1 X 70
321	P0642321	LOCK WASHER 6MM
322	P0642322	HEX NUT M6-1
323	P0642323	SET SCREW M6-1 X 5
324	P0642324	EXT RETAINING RING 16MM
325	P0642325	LOCK COLLAR
326	P0642326	HOLD DOWN ROD
327	P0642327	HOLD DOWN BRACKET
328	P0642328	SET SCREW M5-.8 X 5



Labels & Cosmetics

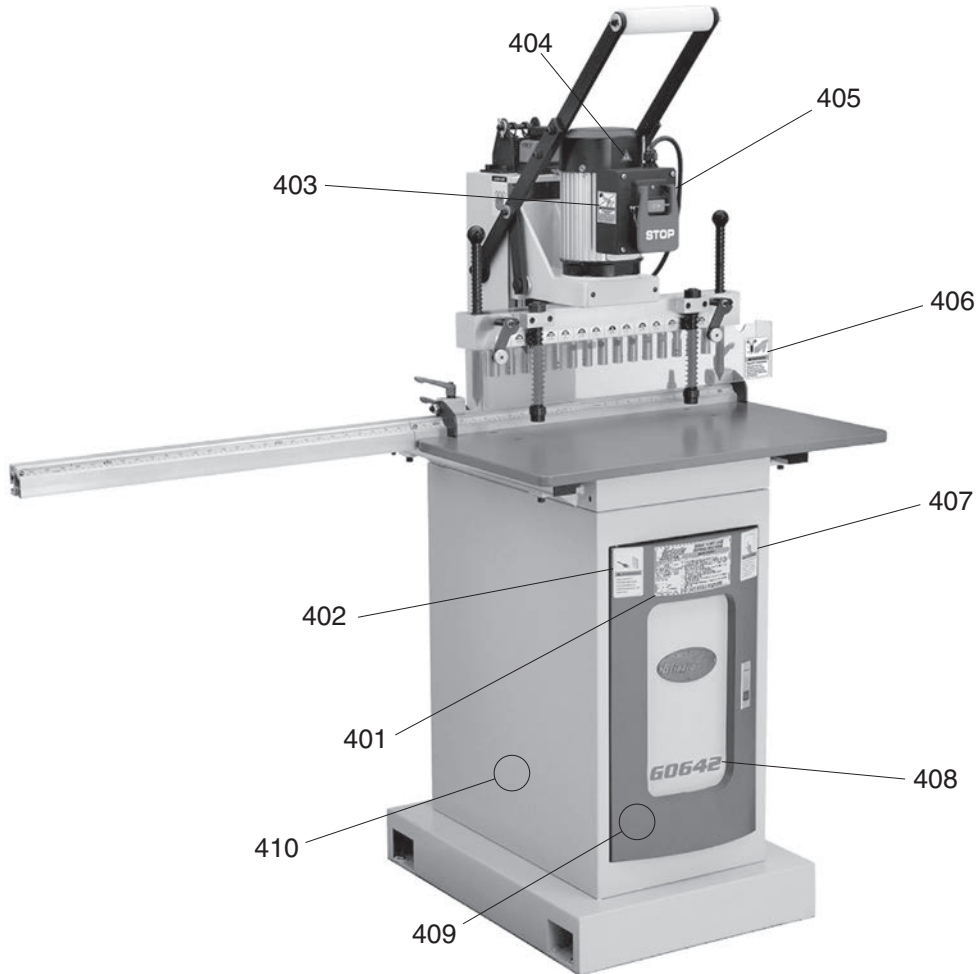

REF	PART #	DESCRIPTION
401	P0642401	MACHINE ID LABEL
402	P0642402	DISCONNECT WARNING LABEL
403	P0642403	ENTANGLEMENT HAZARD LABEL
404	P0642404	ELECTRICITY LABEL
405	P0642405	EYE INJURY HAZARD LABEL

REF	PART #	DESCRIPTION
406	P0642406	HAND INJURY HAZARD LABEL
407	P0642407	READ MANUAL LABEL
408	P0642408	MODEL NUMBER LABEL
409	P0642409	TOUCH-UP PAINT, GRIZZLY GREEN
410	P0642410	TOUCH-UP PAINT, GRIZZLY PUTTY

WARNING

Safety labels help reduce the risk of serious injury caused by machine hazards. If any label comes off or becomes unreadable, the owner of this machine **MUST** replace it in the original location before resuming operations. For replacements, contact (800) 523-4777 or www.grizzly.com.







WARRANTY CARD

Name _____
 Street _____
 City _____ State _____ Zip _____
 Phone # _____ Email _____
 Model # _____ Order # _____ Serial # _____

The following information is given on a voluntary basis. It will be used for marketing purposes to help us develop better products and services. **Of course, all information is strictly confidential.**

1. How did you learn about us?

<input type="checkbox"/> Advertisement	<input type="checkbox"/> Friend	<input type="checkbox"/> Catalog
<input type="checkbox"/> Card Deck	<input type="checkbox"/> Website	<input type="checkbox"/> Other:

2. Which of the following magazines do you subscribe to?

<input type="checkbox"/> Cabinetmaker & FDM	<input type="checkbox"/> Popular Science	<input type="checkbox"/> Wooden Boat
<input type="checkbox"/> Family Handyman	<input type="checkbox"/> Popular Woodworking	<input type="checkbox"/> Woodshop News
<input type="checkbox"/> Hand Loader	<input type="checkbox"/> Precision Shooter	<input type="checkbox"/> Woodsmith
<input type="checkbox"/> Handy	<input type="checkbox"/> Projects in Metal	<input type="checkbox"/> Woodwork
<input type="checkbox"/> Home Shop Machinist	<input type="checkbox"/> RC Modeler	<input type="checkbox"/> Woodworker West
<input type="checkbox"/> Journal of Light Cont.	<input type="checkbox"/> Rifle	<input type="checkbox"/> Woodworker's Journal
<input type="checkbox"/> Live Steam	<input type="checkbox"/> Shop Notes	<input type="checkbox"/> Other:
<input type="checkbox"/> Model Airplane News	<input type="checkbox"/> Shotgun News	
<input type="checkbox"/> Old House Journal	<input type="checkbox"/> Today's Homeowner	
<input type="checkbox"/> Popular Mechanics	<input type="checkbox"/> Wood	

3. What is your annual household income?

<input type="checkbox"/> \$20,000-\$29,000	<input type="checkbox"/> \$30,000-\$39,000	<input type="checkbox"/> \$40,000-\$49,000
<input type="checkbox"/> \$50,000-\$59,000	<input type="checkbox"/> \$60,000-\$69,000	<input type="checkbox"/> \$70,000+

4. What is your age group?

<input type="checkbox"/> 20-29	<input type="checkbox"/> 30-39	<input type="checkbox"/> 40-49
<input type="checkbox"/> 50-59	<input type="checkbox"/> 60-69	<input type="checkbox"/> 70+

5. How long have you been a woodworker/metalworker?

<input type="checkbox"/> 0-2 Years	<input type="checkbox"/> 2-8 Years	<input type="checkbox"/> 8-20 Years	<input type="checkbox"/> 20+ Years
------------------------------------	------------------------------------	-------------------------------------	------------------------------------

6. How many of your machines or tools are Grizzly?

<input type="checkbox"/> 0-2	<input type="checkbox"/> 3-5	<input type="checkbox"/> 6-9	<input type="checkbox"/> 10+
------------------------------	------------------------------	------------------------------	------------------------------

7. Do you think your machine represents a good value? Yes No
8. Would you recommend Grizzly Industrial to a friend? Yes No
9. Would you allow us to use your name as a reference for Grizzly customers in your area?
Note: We never use names more than 3 times. Yes No

10. Comments: _____

CUT ALONG DOTTED LINE

FOLD ALONG DOTTED LINE



Place
Stamp
Here



GRIZZLY INDUSTRIAL, INC.
P.O. BOX 2069
BELLINGHAM, WA 98227-2069



FOLD ALONG DOTTED LINE

Send a Grizzly Catalog to a friend:

Name _____

Street _____

City _____ State _____ Zip _____

TAPE ALONG EDGES--PLEASE DO NOT STAPLE

WARRANTY AND RETURNS

Grizzly Industrial, Inc. warrants every product it sells for a period of **1 year** to the original purchaser from the date of purchase. This warranty does not apply to defects due directly or indirectly to misuse, abuse, negligence, accidents, repairs or alterations or lack of maintenance. This is Grizzly's sole written warranty and any and all warranties that may be implied by law, including any merchantability or fitness, for any particular purpose, are hereby limited to the duration of this written warranty. We do not warrant or represent that the merchandise complies with the provisions of any law or acts unless the manufacturer so warrants. In no event shall Grizzly's liability under this warranty exceed the purchase price paid for the product and any legal actions brought against Grizzly shall be tried in the State of Washington, County of Whatcom.

We shall in no event be liable for death, injuries to persons or property or for incidental, contingent, special, or consequential damages arising from the use of our products.

To take advantage of this warranty, contact us by mail or phone and give us all the details. We will then issue you a "Return Number," which must be clearly posted on the outside as well as the inside of the carton. We will not accept any item back without this number. Proof of purchase must accompany the merchandise.

The manufacturers reserve the right to change specifications at any time because they constantly strive to achieve better quality equipment. We make every effort to ensure that our products meet high quality and durability standards and we hope you never need to use this warranty.

Please feel free to write or call us if you have any questions about the machine or the manual.

Thank you again for your business and continued support. We hope to serve you again soon.

grizzly.com[®]

TOOL WEBSITE

Buy Direct and Save with Grizzly[®] – Trusted, Proven and a Great Value!
~Since 1983~

*Visit Our Website Today For
Current Specials!*

**ORDER
24 HOURS A DAY!
1-800-523-4777**

