

# *Grizzly* **Industrial, Inc.**®

## MODEL G0563/G0564 OSCILLATING EDGE SANDER

### OWNER'S MANUAL

*(For models manufactured since 10/11)*



COPYRIGHT © JULY, 2004 BY GRIZZLY INDUSTRIAL, INC., REVISED MARCH 2017 (TR)  
WARNING: NO PORTION OF THIS MANUAL MAY BE REPRODUCED IN ANY SHAPE  
OR FORM WITHOUT THE WRITTEN APPROVAL OF GRIZZLY INDUSTRIAL, INC.

#CA6304 PRINTED IN TAIWAN

V2.09.14



## **WARNING!**

**This manual provides critical safety instructions on the proper setup, operation, maintenance, and service of this machine/tool. Save this document, refer to it often, and use it to instruct other operators.**

**Failure to read, understand and follow the instructions in this manual may result in fire or serious personal injury—including amputation, electrocution, or death.**

**The owner of this machine/tool is solely responsible for its safe use. This responsibility includes but is not limited to proper installation in a safe environment, personnel training and usage authorization, proper inspection and maintenance, manual availability and comprehension, application of safety devices, cutting/sanding/grinding tool integrity, and the usage of personal protective equipment.**

**The manufacturer will not be held liable for injury or property damage from negligence, improper training, machine modifications or misuse.**



## **WARNING!**

**Some dust created by power sanding, sawing, grinding, drilling, and other construction activities contains chemicals known to the State of California to cause cancer, birth defects or other reproductive harm. Some examples of these chemicals are:**

- **Lead from lead-based paints.**
- **Crystalline silica from bricks, cement and other masonry products.**
- **Arsenic and chromium from chemically-treated lumber.**

**Your risk from these exposures varies, depending on how often you do this type of work. To reduce your exposure to these chemicals: Work in a well ventilated area, and work with approved safety equipment, such as those dust masks that are specially designed to filter out microscopic particles.**

# Table of Contents

<b>INTRODUCTION</b> .....	<b>2</b>	<b>SECTION 5: ACCESSORIES</b> .....	<b>28</b>
Machine Description .....	2	<b>SECTION 6: MAINTENANCE</b> .....	<b>29</b>
Contact Info.....	2	General .....	29
Manual Accuracy .....	2	Lubrication .....	29
G0563 Machine Data Sheet .....	3	Tables .....	31
G0564 Machine Data Sheet .....	5	Spindle Connector .....	31
Machine Features .....	7	Eccentric .....	31
<b>SECTION 1: SAFETY</b> .....	<b>8</b>	<b>SECTION 7: SERVICE</b> .....	<b>32</b>
Safety Instructions for Machinery .....	8	Troubleshooting Machine.....	32
Additional Safety for Oscillating Edge Sanders.....	10	Troubleshooting Sanding.....	33
<b>SECTION 2: POWER SUPPLY</b> .....	<b>11</b>	About Service.....	34
<b>SECTION 3: SET UP</b> .....	<b>13</b>	Calibrating Angle Gauge.....	34
Needed for Setup.....	13	Removing Drive Roller.....	35
Unpacking .....	13	<b>SECTION 8: WIRING</b> .....	<b>36</b>
Inventory .....	14	Wiring Safety Instructions .....	36
Cleanup.....	15	G0563 Wiring Diagram .....	37
Site Considerations.....	16	G0564 Wiring Diagram .....	38
Hardware Recognition Chart .....	17	<b>SECTION 9: PARTS</b> .....	<b>39</b>
Back Stop.....	18	G0563 Breakdown .....	39
Dust Port Cover .....	18	G0564 Breakdown .....	43
Dust Ports .....	19	<b>WARRANTY &amp; RETURNS</b> .....	<b>49</b>
Dust Collection.....	19		
Test Run .....	20		
<b>SECTION 4: OPERATIONS</b> .....	<b>21</b>		
Sanding Belts.....	21		
Emergency Stop Button.....	21		
Installing Belt.....	22		
Belt Tracking .....	22		
Platen Angle Adjustment .....	23		
Table Adjustment.....	23		
Miter Gauge .....	24		
Sanding Spindle.....	25		
Spindle Table Height .....	26		
Spindle Sanding.....	26		
Edge & End Sanding .....	27		
Fence .....	27		

# INTRODUCTION

## Machine Description

The Model G0563/G0564 Oscillating Edge Sander features an oscillating belt and spindle drum, two dust ports, a T-Slot and miter gauge, and a quick release tension lever. Vertical adjustment of the edge-sanding table is handwheel-controlled, and the sanding belt tilts from 0 to 90 degrees.

Both models are equipped with a 240V, single-phase motor. Model G0563 comes with a 2 HP, 9A motor, and Model G0564 is powered by a 3 HP, 9A motor.

## Contact Info

We stand behind our machines! If you have questions or need help, contact us with the information below. Before contacting, make sure you get the **serial number** and **manufacture date** from the machine ID label. This will help us help you faster.

Grizzly Technical Support  
1815 W. Battlefield  
Springfield, MO 65807  
Phone: (570) 546-9663  
Email: techsupport@grizzly.com

We want your feedback on this manual. What did you like about it? Where could it be improved? Please take a few minutes to give us feedback.

Grizzly Documentation Manager  
P.O. Box 2069  
Bellingham, WA 98227-2069  
Email: manuals@grizzly.com

## Manual Accuracy

We are proud to provide a high-quality owner's manual with your new machine!

We made every effort to be exact with the instructions, specifications, drawings, and photographs in this manual. Sometimes we make mistakes, but our policy of continuous improvement also means that **sometimes the machine you receive is slightly different than shown in the manual.**

If you find this to be the case, and the difference between the manual and machine leaves you confused or unsure about something, check our website for an updated version. We post current manuals and manual updates for free on our website at [www.grizzly.com](http://www.grizzly.com).

Alternatively, you can call our Technical Support for help. Before calling, make sure you write down the **Manufacture Date** and **Serial Number** from the machine ID label (see below). This information is required for us to provide proper tech support, and it helps us determine if updated documentation is available for your machine.

		<b>MODEL GXXXX</b> <b>MACHINE NAME</b>	
<b>SPECIFICATIONS</b>		<b>WARNING!</b>	
Motor:		To reduce risk of serious injury when using this machine:	
Specification:		1. Read manual before operation.	
Specification:		2. Wear safety glasses and respirator.	
Specification:		3. Make sure machine is properly adjusted/setup and	
Specification:		4. power is connected to grounded circuit before starting.	
Weight:		5. Make sure the motor has stopped and disconnect	
		6. power before adjustments, maintenance, or service.	
		7. DO NOT expose to rain or dampness.	
		8. DO NOT modify this machine in any way.	
		9. Do not use while intoxicated by drugs or alcohol.	
		10. Maintain machine carefully to prevent accidents.	
		Manufactured for Grizzly in Taiwan	

Manufacture Date

Serial Number





# MACHINE DATA SHEET

Customer Service #: (570) 546-9663 · To Order Call: (800) 523-4777 · Fax #: (800) 438-5901

## MODEL G0563 OSCILLATING EDGE SANDER 2 HP

### Product Dimensions:

Weight..... 396 lbs.  
Width (side-to-side) x Depth (front-to-back) x Height..... 50-1/2 x 23 x 49 in.  
Footprint (Length x Width)..... 22-1/2 x 19-1/2 in.

### Shipping Dimensions:

Type..... Wood Crate  
Content..... Machine  
Weight..... 504 lbs.  
Length x Width x Height..... 48 x 30 x 44 in.  
Must Ship Upright..... Yes

### Electrical:

Power Requirement..... 240V, Single-Phase, 60 Hz  
Prewired Voltage..... 240V  
Full-Load Current Rating..... 9A  
Minimum Circuit Size..... 15A  
Connection Type..... Cord & Plug  
Power Cord Included..... Yes  
Power Cord Length..... 10 ft.  
Power Cord Gauge..... 14 AWG  
Plug Included..... No  
Recommended Plug Type..... 6-15  
Switch Type..... Magnetic Switch w/Overload Protection

### Motors:

#### Main

Type..... TEFC Capacitor-Start Induction  
Horsepower..... 2 HP  
Phase..... Single-Phase  
Amps..... 9A  
Speed..... 1725 RPM  
Power Transfer..... Direct Drive  
Bearings..... Shielded & Permanently Lubricated

### Main Specifications:

#### Operation Information

Sanding Belt Speed..... 3150 FPM  
Sanding Belt Oscillations..... 1/4 in.  
Sanding Belt Length..... 89 in.  
Sanding Belt Width..... 6 in.  
Sanding Belt Tilt..... 0 – 90 deg.



**Table Information**

Table Length.....	26-7/8 in.
Table Width.....	12 in.
Table Thickness.....	1-1/4 in.
Table Travel.....	3-3/4 in.
Floor To Table Height.....	35-3/4 – 39-1/2 in.
End Table Length.....	11-1/2 in.
End Table Width.....	10 in.
End Table Thickness.....	3/4 in.
End Table Travel.....	10 in.

**Platen Information**

Platen Type.....	Graphite Coated
Platen Length.....	30-1/4 in.
Platen Width.....	6-3/4 in.

**Construction**

Table.....	Precision-Ground Cast Iron
Frame.....	Steel
Base.....	Steel
Drive Roller.....	Aluminum
Idler Roller.....	Rubber
Paint Type/Finish.....	Powder Coated

**Other Related Information**

Number of Dust Ports.....	2
Dust Port Size.....	4 in.
Belt Release.....	Quick Release
Drive Roller Size.....	7 in.
Idler Roller Size.....	3-7/8 in.

**Other Specifications:**

Country of Origin .....	Taiwan
Warranty .....	1 Year
Approximate Assembly & Setup Time .....	15 Minutes
Serial Number Location .....	ID Label on Base
Sound Rating .....	90 dB
ISO 9001 Factory .....	No
Certified by a Nationally Recognized Testing Laboratory (NRTL) .....	Yes

**Features:**

- Sanding Surface Tilts Vertical to Horizontal
- T-Slot Table and Miter Gauge
- Quick Release Belt Tension Lever
- Graphite Coated Platen
- Oscillating Sanding Surfaces
- Sanding Belt Oscillates at 52 Cycles per Minute
- Includes 3 Spindles Drums: 1 1/2", 2", 3" x 4 1/2"
- Platen Tilts 0 to 90 degrees (5 deg. Scale)





# MACHINE DATA SHEET

Customer Service #: (570) 546-9663 · To Order Call: (800) 523-4777 · Fax #: (800) 438-5901

## MODEL G0564 OSCILLATING EDGE SANDER 3 HP

### Product Dimensions:

Weight..... 495 lbs.  
 Width (side-to-side) x Depth (front-to-back) x Height..... 60 x 28 x 49 in.  
 Footprint (Length x Width)..... 32 x 19-1/2 in.

### Shipping Dimensions:

Type..... Wood Crate  
 Content..... Machine  
 Weight..... 597 lbs.  
 Length x Width x Height..... 58 x 30 x 44 in.  
 Must Ship Upright..... Yes

### Electrical:

Power Requirement..... 240V, Single-Phase, 60 Hz  
 Prewired Voltage..... 240V  
 Full-Load Current Rating..... 11A  
 Minimum Circuit Size..... 15A  
 Connection Type..... Cord & Plug  
 Power Cord Included..... Yes  
 Power Cord Length..... 10 ft.  
 Power Cord Gauge..... 12 AWG  
 Plug Included..... Yes  
 Included Plug Type..... NEMA 6-15  
 Switch Type..... Magnetic Switch w/Overload Protection

### Motors:

#### Main

Type..... TEFC Capacitor-Start Induction  
 Horsepower..... 3 HP  
 Phase..... Single-Phase  
 Amps..... 11A  
 Speed..... 1725 RPM  
 Power Transfer ..... Direct Drive  
 Bearings..... Shielded & Permanently Lubricated

### Main Specifications:

#### Operation Information

Sanding Belt Speed..... 3150 FPM  
 Sanding Belt Oscillations..... 1/4 in.  
 Sanding Belt Length..... 108 in.  
 Sanding Belt Width..... 6 in.  
 Sanding Belt Tilt..... 0 – 90 deg.



**Table Information**

Table Length.....	35-1/2 in.
Table Width.....	12 in.
Table Thickness.....	1-1/2 in.
Table Travel.....	4 in.
Floor To Table Height.....	35-3/4 – 39-3/4 in.
End Table Length.....	11-1/2 in.
End Table Width.....	10 in.
End Table Thickness.....	3/4 in.
End Table Travel.....	10 in.

**Platen Information**

Platen Type.....	Graphite Coated
Platen Length.....	39-3/4 in.
Platen Width.....	6-3/4 in.

**Construction**

Table.....	Precision Ground Cast Iron
Frame.....	Steel
Base.....	Steel
Drive Roller.....	Aluminum
Idler Roller.....	Rubber
Miter Block.....	Aluminum
Paint Type/Finish.....	Powder Coated

**Other Related Information**

Number of Dust Ports.....	2
Dust Port Size.....	4 in.
Belt Release.....	Quick Release
Drive Roller Size.....	7 in.
Idler Roller Size.....	3-7/8 in.

**Other Specifications:**

Country of Origin .....	Taiwan
Warranty .....	1 Year
Approximate Assembly & Setup Time .....	15 Minutes
Serial Number Location .....	ID Label on Base
Sound Rating .....	90 dB
ISO 9001 Factory .....	No
Certified by a Nationally Recognized Testing Laboratory (NRTL) .....	Yes

**Features:**

- Sanding Surfaces Tilts Vertical and Horizontal
- T-Slot Table and Miter Gauge
- Quick Belt Release Lever
- Graphite Coated Platen
- Oscillating Sanding Surfaces
- Sanding Belt Oscillates at 52 Cycles per Minute
- Includes 3 Sanding Drums: 1 1/2", 2", 3" x 4 1/2"
- Platen Tilts 0 to 90 degrees (5 deg. Scale)





# Machine Features

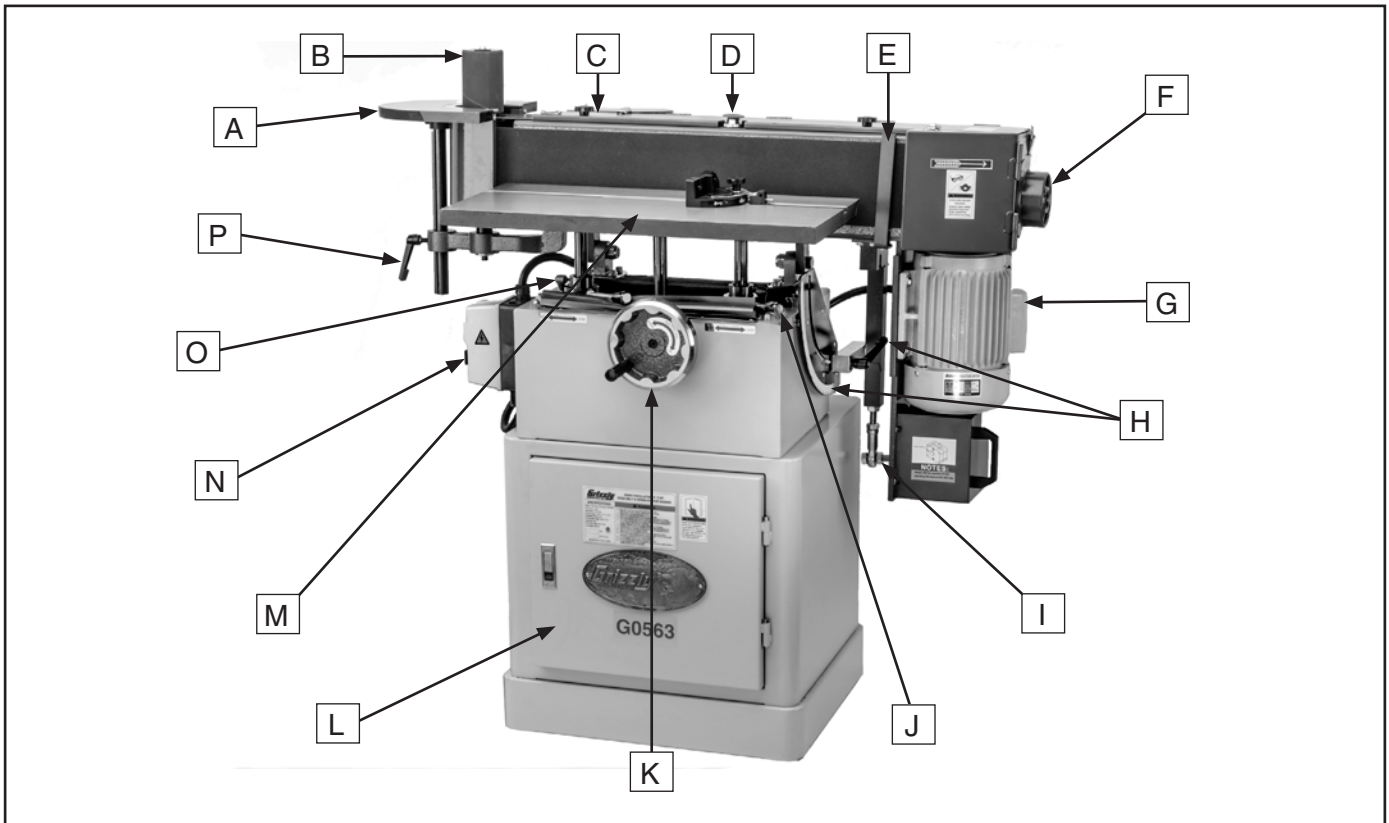

**Figure 1.** Main features of the G0563/G0564.

- |                                   |   |
|-----------------------------------|---|
| A. Sanding Spindle Table          | I. Belt Tracking Adjustment             |
| B. Sanding Spindle                | J. Table Lock Levers                    |
| C. Belt Access Door               | K. Vertical Adjustment Handwheel        |
| D. Emergency Stop Switch          | L. Storage Compartment                  |
| E. Back Stop                      | M. Sanding Table                        |
| F. Rear Dust Port                 | N. ON/OFF Switch                        |
| G. Motor                          | O. Vertical Adjustment Lock Handles     |
| H. Angle Adjustment & Lock Handle | P. Spindle Table Adjustment Lock Handle |

## **! WARNING**

**For Your Own Safety Read This Manual  
Before Operating Sander**

- a) Wear eye protection.
- b) Support workpiece on worktable.
- c) Minimize pinch hazards. Use the smallest table insert possible with sanding drum.
- d) Avoid kickback. Feed workpiece against rotation of drum.
- e) Avoid entanglement with spinning drum. Do not wear gloves, necktie, or loose clothing. Tie back long hair.



# SECTION 1: SAFETY

## For Your Own Safety, Read Instruction Manual Before Operating This Machine

The purpose of safety symbols is to attract your attention to possible hazardous conditions. This manual uses a series of symbols and signal words intended to convey the level of importance of the safety messages. The progression of symbols is described below. Remember that safety messages by themselves do not eliminate danger and are not a substitute for proper accident prevention measures. Always use common sense and good judgment.

 **DANGER** Indicates an imminently hazardous situation which, if not avoided, **WILL** result in death or serious injury.

 **WARNING** Indicates a potentially hazardous situation which, if not avoided, **COULD** result in death or serious injury.

 **CAUTION** Indicates a potentially hazardous situation which, if not avoided, **MAY** result in minor or moderate injury. It may also be used to alert against unsafe practices.

**NOTICE** This symbol is used to alert the user to useful information about proper operation of the machine.

## Safety Instructions for Machinery

### **WARNING**

**OWNER'S MANUAL.** Read and understand this owner's manual **BEFORE** using machine.

**TRAINED OPERATORS ONLY.** Untrained operators have a higher risk of being hurt or killed. Only allow trained/supervised people to use this machine. When machine is not being used, disconnect power, remove switch keys, or lock-out machine to prevent unauthorized use—especially around children. Make workshop kid proof!

**DANGEROUS ENVIRONMENTS.** Do not use machinery in areas that are wet, cluttered, or have poor lighting. Operating machinery in these areas greatly increases the risk of accidents and injury.

**MENTAL ALERTNESS REQUIRED.** Full mental alertness is required for safe operation of machinery. Never operate under the influence of drugs or alcohol, when tired, or when distracted.

**ELECTRICAL EQUIPMENT INJURY RISKS.** You can be shocked, burned, or killed by touching live electrical components or improperly grounded machinery. To reduce this risk, only allow qualified service personnel to do electrical installation or repair work, and always disconnect power before accessing or exposing electrical equipment.

**DISCONNECT POWER FIRST.** Always disconnect machine from power supply **BEFORE** making adjustments, changing tooling, or servicing machine. This prevents an injury risk from unintended startup or contact with live electrical components.

**EYE PROTECTION.** Always wear ANSI-approved safety glasses or a face shield when operating or observing machinery to reduce the risk of eye injury or blindness from flying particles. Everyday eyeglasses are **NOT** approved safety glasses.



# WARNING

**WEARING PROPER APPAREL.** Do not wear clothing, apparel or jewelry that can become entangled in moving parts. Always tie back or cover long hair. Wear non-slip footwear to reduce risk of slipping and losing control or accidentally contacting cutting tool or moving parts.

**HAZARDOUS DUST.** Dust created by machinery operations may cause cancer, birth defects, or long-term respiratory damage. Be aware of dust hazards associated with each workpiece material. Always wear a NIOSH-approved respirator to reduce your risk.

**HEARING PROTECTION.** Always wear hearing protection when operating or observing loud machinery. Extended exposure to this noise without hearing protection can cause permanent hearing loss.

**REMOVE ADJUSTING TOOLS.** Tools left on machinery can become dangerous projectiles upon startup. Never leave chuck keys, wrenches, or any other tools on machine. Always verify removal before starting!

**USE CORRECT TOOL FOR THE JOB.** Only use this tool for its intended purpose—do not force it or an attachment to do a job for which it was not designed. Never make unapproved modifications—modifying tool or using it differently than intended may result in malfunction or mechanical failure that can lead to personal injury or death!

**AWKWARD POSITIONS.** Keep proper footing and balance at all times when operating machine. Do not overreach! Avoid awkward hand positions that make workpiece control difficult or increase the risk of accidental injury.

**CHILDREN & BYSTANDERS.** Keep children and bystanders at a safe distance from the work area. Stop using machine if they become a distraction.

**GUARDS & COVERS.** Guards and covers reduce accidental contact with moving parts or flying debris. Make sure they are properly installed, undamaged, and working correctly **BEFORE** operating machine.

**FORCING MACHINERY.** Do not force machine. It will do the job safer and better at the rate for which it was designed.

**NEVER STAND ON MACHINE.** Serious injury may occur if machine is tipped or if the cutting tool is unintentionally contacted.

**STABLE MACHINE.** Unexpected movement during operation greatly increases risk of injury or loss of control. Before starting, verify machine is stable and mobile base (if used) is locked.

**USE RECOMMENDED ACCESSORIES.** Consult this owner's manual or the manufacturer for recommended accessories. Using improper accessories will increase the risk of serious injury.

**UNATTENDED OPERATION.** To reduce the risk of accidental injury, turn machine **OFF** and ensure all moving parts completely stop before walking away. Never leave machine running while unattended.

**MAINTAIN WITH CARE.** Follow all maintenance instructions and lubrication schedules to keep machine in good working condition. A machine that is improperly maintained could malfunction, leading to serious personal injury or death.

**DAMAGED PARTS.** Regularly inspect machine for damaged, loose, or mis-adjusted parts—or any condition that could affect safe operation. Immediately repair/replace **BEFORE** operating machine. For your own safety, **DO NOT** operate machine with damaged parts!

**MAINTAIN POWER CORDS.** When disconnecting cord-connected machines from power, grab and pull the plug—**NOT** the cord. Pulling the cord may damage the wires inside. Do not handle cord/plug with wet hands. Avoid cord damage by keeping it away from heated surfaces, high traffic areas, harsh chemicals, and wet/damp locations.

**EXPERIENCING DIFFICULTIES.** If at any time you experience difficulties performing the intended operation, stop using the machine! Contact our Technical Support at (570) 546-9663.



# Additional Safety for Oscillating Edge Sanders

## **WARNING**

**WORKPIECE PRESSURE.** Do not jam the workpiece against the sanding surfaces. Firmly grasp the workpiece in both hands and ease it against the belt/spindle using light pressure.

**HAND PLACEMENT.** Do not place hands near, or in contact with, sanding surfaces during operation.

**WORKPIECE HANDLING.** Grip the workpiece with both hands.

**MAINTENANCE.** Perform machine inspections and maintenance promptly as required.

**SANDING BELTS/DRUMS.** Replace sanding belts and drums promptly as needed.

**WORKPIECE QUANTITY.** Never sand more than one piece of stock at a time.

**FOREIGN MATERIAL.** Always inspect stock for nails, staples, knots, and other imperfections that could be dislodged and thrown from the machine during sanding operations.

**DUST COLLECTION.** Never operate the sander without an adequate dust collection system in place and running.

**DIRECTION.** Never sand tapered or pointed stock with the point facing the feed direction.

**POWER DISCONNECT.** Disconnect the machine from the power source before changing the sanding belt or sleeve.

**TEST RUN.** Test run the machine before starting any work.

## **WARNING**

Like all machinery there is potential danger when operating this machine. Accidents are frequently caused by lack of familiarity or failure to pay attention. Use this machine with respect and caution to decrease the risk of operator injury. If normal safety precautions are overlooked or ignored, serious personal injury may occur.

## **CAUTION**

No list of safety guidelines can be complete. Every shop environment is different. Always consider safety first, as it applies to your individual working conditions. Use this and other machinery with caution and respect. Failure to do so could result in serious personal injury, damage to equipment, or poor work results.



# SECTION 2: POWER SUPPLY

## Availability

Before installing the machine, consider the availability and proximity of the required power supply circuit. If an existing circuit does not meet the requirements for this machine, a new circuit must be installed. To minimize the risk of electrocution, fire, or equipment damage, installation work and electrical wiring must be done by an electrician or qualified service personnel in accordance with all applicable codes and standards.

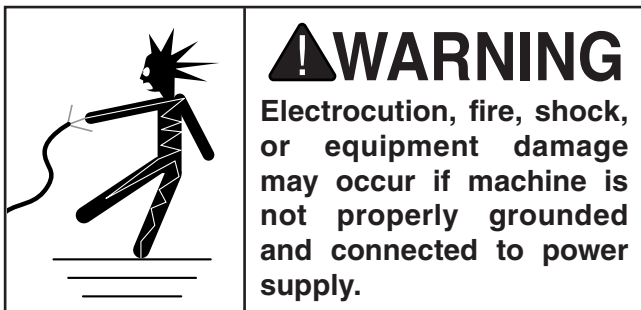

## Full-Load Current Rating

The full-load current rating is the amperage a machine draws at 100% of the rated output power. On machines with multiple motors, this is the amperage drawn by the largest motor or sum of all motors and electrical devices that might operate at one time during normal operations.

**G0563 Full-Load Current Rating ..... 9 Amps**  
**G0564 Full-Load Current Rating ..... 11 Amps**

The full-load current is not the maximum amount of amps that the machine will draw. If the machine is overloaded, it will draw additional amps beyond the full-load rating.

If the machine is overloaded for a sufficient length of time, damage, overheating, or fire may result—especially if connected to an undersized circuit. To reduce the risk of these hazards, avoid overloading the machine during operation and make sure it is connected to a power supply circuit that meets the specified circuit requirements.

## Circuit Information

A power supply circuit includes all electrical equipment between the breaker box or fuse panel in the building and the machine. The power supply circuit used for this machine must be sized to safely handle the full-load current drawn from the machine for an extended period of time. (If this machine is connected to a circuit protected by fuses, use a time delay fuse marked D.)

**⚠ CAUTION**  
For your own safety and protection of property, consult an electrician if you are unsure about wiring practices or electrical codes in your area.

**Note:** *Circuit requirements in this manual apply to a dedicated circuit—where only one machine will be running on the circuit at a time. If machine will be connected to a shared circuit where multiple machines may be running at the same time, consult an electrician or qualified service personnel to ensure circuit is properly sized for safe operation.*

## Circuit Requirements

This machine is prewired to operate on a power supply circuit that has a verified ground and meets the following requirements:

**Nominal Voltage ..... 240V**  
**Cycle ..... 60 Hz**  
**Phase ..... Single-Phase**  
**Power Supply Circuit ..... 15 Amps**  
**Plug/Receptacle ..... NEMA 6-15**



## Grounding Requirements

This machine **MUST** be grounded. In the event of certain malfunctions or breakdowns, grounding reduces the risk of electric shock by providing a path of least resistance for electric current.

This machine is equipped with a power cord that has an equipment-grounding wire and a grounding plug. Only insert plug into a matching receptacle (outlet) that is properly installed and grounded in accordance with all local codes and ordinances. **DO NOT** modify the provided plug!

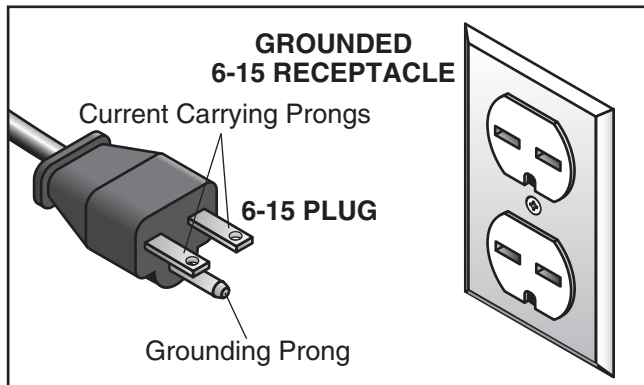

**Figure 2.** Typical 6-15 plug and receptacle.

## **!** CAUTION

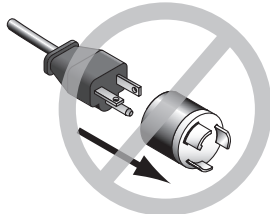

**No adapter should be used with plug. If plug does not fit available receptacle, or if machine must be reconnected for use on a different type of circuit, reconnection must be performed by an electrician or qualified service personnel, and it must comply with all local codes and ordinances.**

## **!** WARNING

**Serious injury could occur if you connect machine to power before completing setup process. DO NOT connect to power until instructed later in this manual.**

Improper connection of the equipment-grounding wire can result in a risk of electric shock. The wire with green insulation (with or without yellow stripes) is the equipment-grounding wire. If repair or replacement of the power cord or plug is necessary, do not connect the equipment-grounding wire to a live (current carrying) terminal.

Check with a qualified electrician or service personnel if you do not understand these grounding requirements, or if you are in doubt about whether the tool is properly grounded. If you ever notice that a cord or plug is damaged or worn, disconnect it from power, and immediately replace it with a new one.

## Extension Cords

We do not recommend using an extension cord with this machine. If you must use an extension cord, only use it if absolutely necessary and only on a temporary basis.

Extension cords cause voltage drop, which can damage electrical components and shorten motor life. Voltage drop increases as the extension cord size gets longer and the gauge size gets smaller (higher gauge numbers indicate smaller sizes).

Any extension cord used with this machine must be in good condition and contain a ground wire and matching plug/receptacle. Additionally, it must meet the following size requirements:

**Minimum Gauge Size ..... 14 AWG**  
**Maximum Length (Shorter is Better).....50 ft.**



# SECTION 3: SET UP

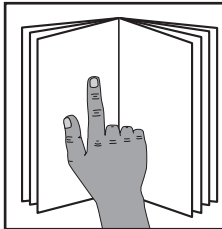

## **!WARNING**

To reduce your risk of serious injury, read this entire manual **BEFORE** using machine.

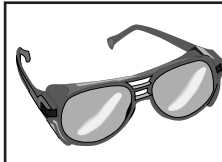

## **!WARNING**

Wear safety glasses during the entire setup process!

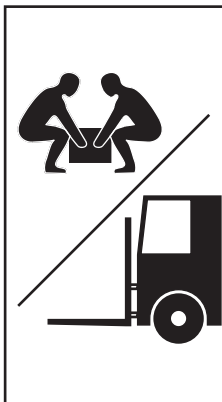

## **!WARNING**

### HEAVY LIFT!

Straining or crushing injury may occur from improperly lifting machine or some of its parts. To reduce this risk, get help from other people and use a forklift (or other lifting equipment) rated for weight of this machine.

## Needed for Setup

The following are needed to complete the setup process, but are not included with your machine:

Description	Qty
• Phillips Screwdriver #2 .....	1
• Flat Head Screwdriver .....	1
• Machinist's Square .....	1
• Hammer .....	1
• Socket 7/8" .....	1
• Ratchet w/6" extension .....	1
• Hex Wrench 4mm.....	1
• Dust Collector .....	1
• Dust Hoses .....	2
• Hose Clamps .....	2

## Unpacking

This machine was carefully packaged for safe transport. When unpacking, separate all enclosed items from packaging materials and inspect them for shipping damage. ***If items are damaged, please call us immediately at (570) 546-9663.***

**IMPORTANT:** Save all packaging materials until you are completely satisfied with the machine and have resolved any issues between Grizzly or the shipping agent. ***You MUST have the original packaging to file a freight claim. It is also extremely helpful if you need to return your machine later.***

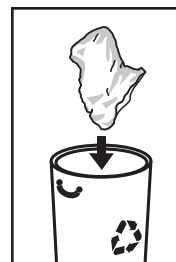

## **!WARNING**

### SUFFOCATION HAZARD!

Keep children and pets away from plastic bags or packing materials shipped with this machine. Discard immediately.



# Inventory



**Figure 3.** Box contents.

After all the parts have been removed from the packaging, you should have the following items:

**Box Contents: (Figure 3)**

<b>A.</b>	Fence.....	1
<b>B.</b>	Front Dust Port.....	1
<b>C.</b>	Spindle Table Assembly.....	1
<b>D.</b>	Sanding Belt.....	1
<b>E.</b>	Rear Dust Port Cover.....	1
<b>F.</b>	Rear Dust Port.....	1
<b>G.</b>	Table Insert 1½".....	1
<b>H.</b>	Table Insert 2".....	1
<b>I.</b>	Table Insert 3".....	1
<b>J.</b>	Sanding Drum 3".....	1
<b>K.</b>	Sanding Drum 2".....	1
<b>L.</b>	Sanding Drum 1½".....	1
<b>M.</b>	Spindle.....	1
<b>N.</b>	Miter Gauge.....	1
<b>O.</b>	Back Stop.....	1

<b>P.</b>	Hardware Bag (Not Shown).....	1
	• Lock Handle.....	1
	• Star Knobs 5/16"-18 x 1".....	2
	• Hex Bolts 5/16"-18 x 1".....	2
	• Hex Bolt 5/16"-18 x ½".....	1
	• Phillips Head Screws ¼"-20 x 3/8".....	4
	• Flat Washers ¼".....	4
	• Spindle Washer 5/16".....	1
	• Flat Washers 5/16".....	4
	• Hinge Pins.....	4
	• Wrench 10 x 12mm, Open-End.....	1
	• Hex Wrench 5mm.....	1
	• Hex Wrench 6mm.....	1
	• Rod.....	1
	• Drive Puller Plate.....	1
	• Cap Screw 5/16"-18 x 1¼".....	1
	• Cap Screws ¼"-20 x 1¾".....	2

In the event that any non-proprietary parts are missing (e.g. a nut or a washer), we would be glad to replace them, or for the sake of expediency, replacements can be obtained at your local hardware store.





# Cleanup

The unpainted surfaces of your machine are coated with a heavy-duty rust preventative that prevents corrosion during shipment and storage. This rust preventative works extremely well, but it will take a little time to clean.

Be patient and do a thorough job cleaning your machine. The time you spend doing this now will give you a better appreciation for the proper care of your machine's unpainted surfaces.

There are many ways to remove this rust preventative, but the following steps work well in a wide variety of situations. Always follow the manufacturer's instructions with any cleaning product you use and make sure you work in a well-ventilated area to minimize exposure to toxic fumes.

## Before cleaning, gather the following:

- Disposable rags
- Cleaner/degreaser (WD•40 works well)
- Safety glasses & disposable gloves
- Plastic paint scraper (optional)

## Basic steps for removing rust preventative:

1. Put on safety glasses.
2. Coat the rust preventative with a liberal amount of cleaner/degreaser, then let it soak for 5–10 minutes.
3. Wipe off the surfaces. If your cleaner/degreaser is effective, the rust preventative will wipe off easily. If you have a plastic paint scraper, scrape off as much as you can first, then wipe off the rest with the rag.
4. Repeat **Steps 2–3** as necessary until clean, then coat all unpainted surfaces with a quality metal protectant to prevent rust.

	<b>⚠️ WARNING</b> Gasoline and petroleum products have low flash points and can explode or cause fire if used to clean machinery. Avoid using these products to clean machinery.
--	---

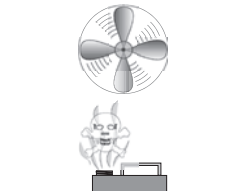
	<b>⚠️ CAUTION</b> Many cleaning solvents are toxic if inhaled. Only work in a well-ventilated area.
--	--

<b>NOTICE</b> Avoid chlorine-based solvents, such as acetone or brake parts cleaner, that may damage painted surfaces.
---

## T23692—Orange Power Degreaser

A great product for removing the waxy shipping grease from your machine during clean up.

<p>Call <b>1-800-523-4777</b> To Order</p>	
--	---



# Site Considerations

## Weight Load

Refer to the **Machine Data Sheet** for the weight of your machine. Make sure that the surface upon which the machine is placed will bear the weight of the machine, additional equipment that may be installed on the machine, and the heaviest workpiece that will be used. Additionally, consider the weight of the operator and any dynamic loading that may occur when operating the machine.

## Space Allocation

Consider the largest size of workpiece that will be processed through this machine and provide enough space around the machine for adequate operator material handling or the installation of auxiliary equipment. With permanent installations, leave enough space around the machine to open or remove doors/covers as required by the maintenance and service described in this manual. **See below for required space allocation.**

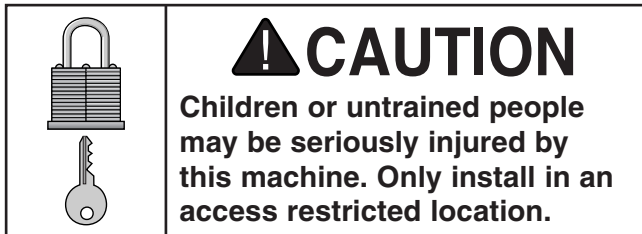

## Physical Environment

The physical environment where the machine is operated is important for safe operation and longevity of machine components. For best results, operate this machine in a dry environment that is free from excessive moisture, hazardous chemicals, airborne abrasives, or extreme conditions. Extreme conditions for this type of machinery are generally those where the ambient temperature range exceeds 41°–104°F; the relative humidity range exceeds 20%–95% (non-condensing); or the environment is subject to vibration, shocks, or bumps.

## Electrical Installation

Place this machine near an existing power source. Make sure all power cords are protected from traffic, material handling, moisture, chemicals, or other hazards. Make sure to leave enough space around machine to disconnect power supply or apply a lockout/tagout device, if required.

## Lighting

Lighting around the machine must be adequate enough that operations can be performed safely. Shadows, glare, or strobe effects that may distract or impede the operator must be eliminated.

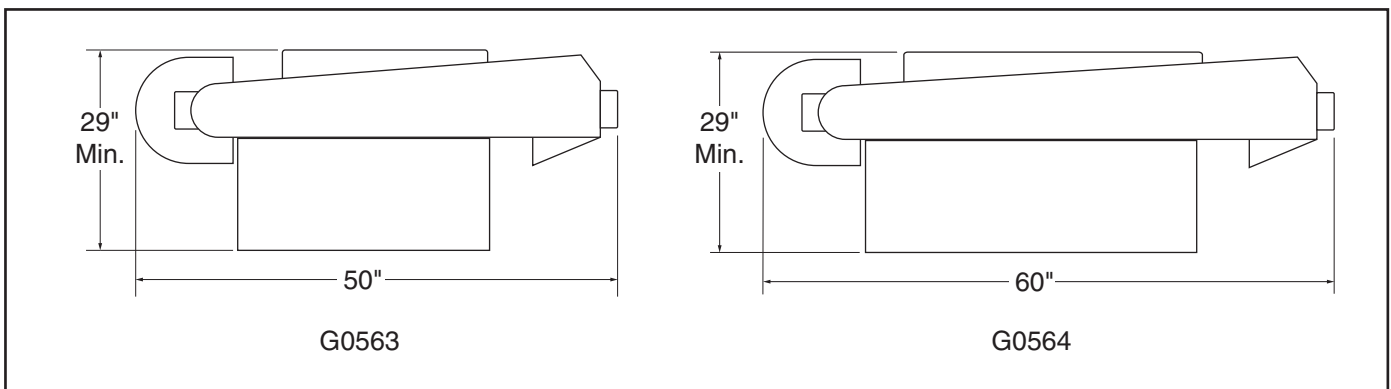

Figure 4. Minimum working clearances.



# Hardware Recognition Chart

USE THIS CHART TO MATCH UP HARDWARE DURING THE ASSEMBLY PROCESS.

MEASURE BOLT DIAMETER BY PLACING INSIDE CIRCLE

- #10
- 1/4"
- 5/16"
- 3/8"
- 7/16"
- 1/2"

- 4mm
- 5mm
- 6mm
- 8mm
- 10mm
- 12mm
- 16mm

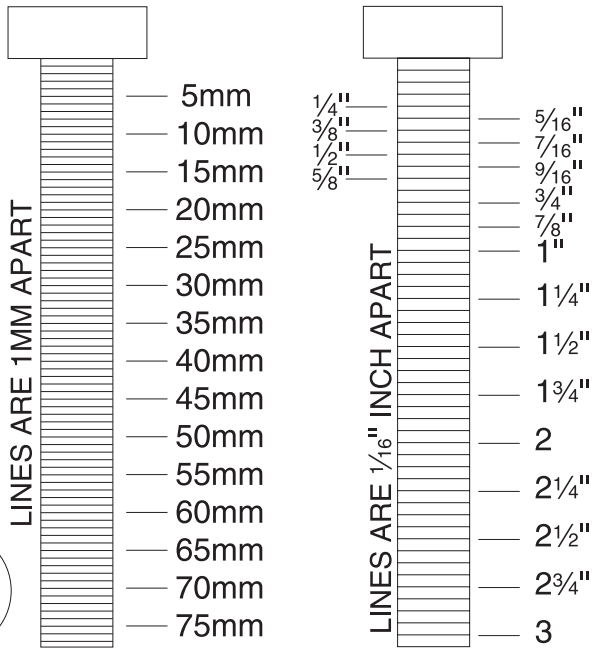
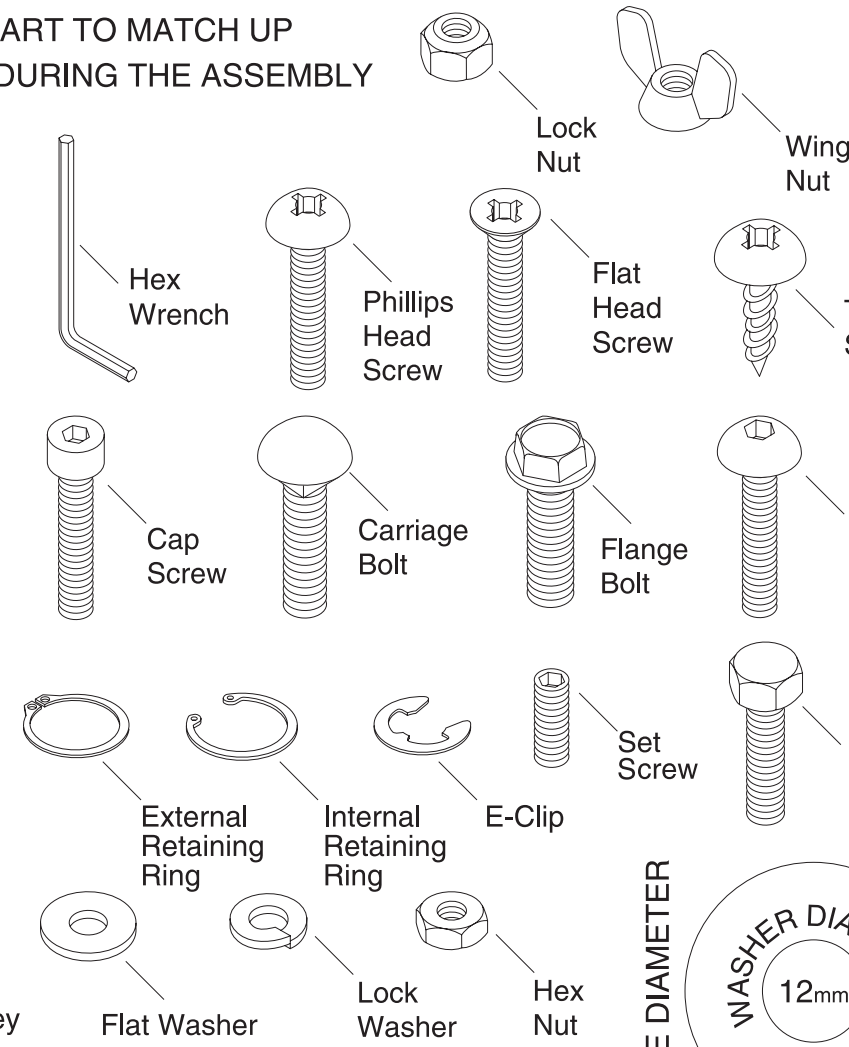

WASHERS ARE MEASURED BY THE INSIDE DIAMETER

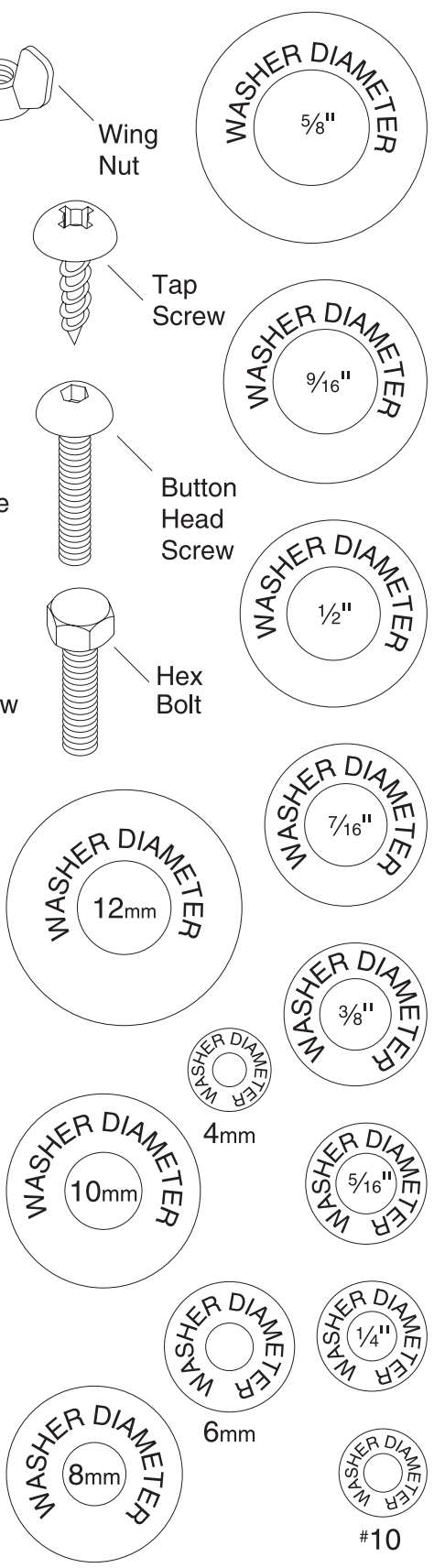

# Back Stop

Components and Hardware Needed:	Qty
Hex Bolts $\frac{5}{16}$ "-18 x 1".....	2
Flat Washers $\frac{5}{16}$ ".....	2
Back Stop.....	1

## Tools Needed:

Open-End Wrench 10 x 12mm.....	1
--------------------------------	---

## To mount back stop:

1. Place a washer on each hex bolt and thread approximately one turn into holes in platen, as shown in **Figure 5**.

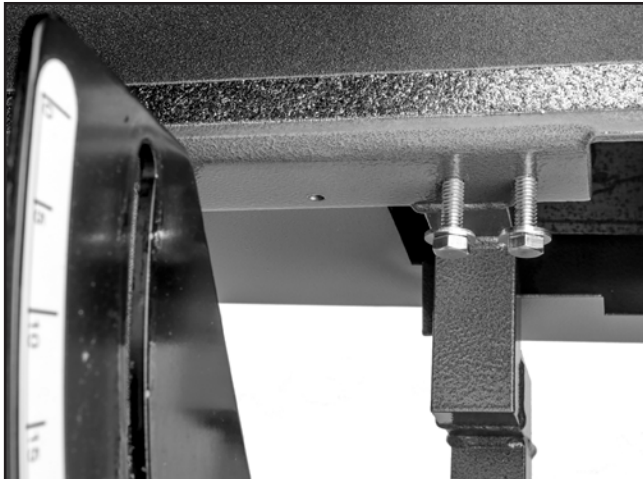

**Figure 5.** Back stop bolts.

2. Slide back stop onto hex bolts and tighten, allowing  $\frac{1}{8}$ " clearance from belt to bottom of the back stop, as shown in **Figure 6**.



**Figure 6.** Back stop installed.

# Dust Port Cover

Components and Hardware Needed:	Qty
Dust Port Cover.....	1
Hinge Pins.....	2

## Tools Needed:

Hammer.....	1
-------------	---

## To mount dust port cover:

1. Align dust port cover hinges with hinges on back of sander.
2. Insert hinge pins through aligned hinges, as shown in **Figure 7**, and tap with a hammer for full insertion.

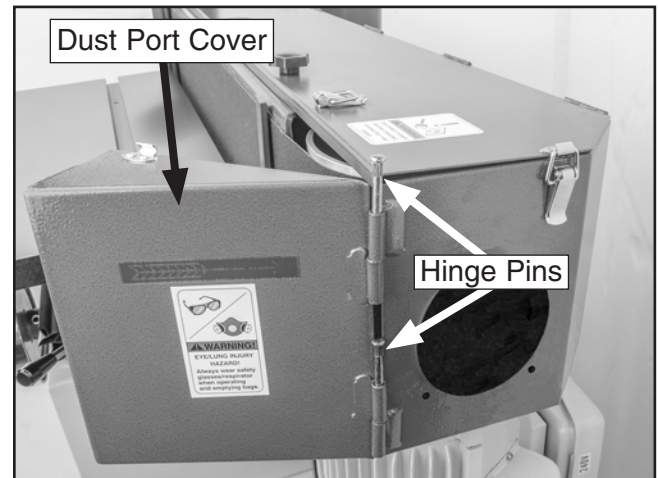

**Figure 7.** Dust port cover installed.

3. Latch belt access door to dust port cover.



# Dust Ports

<b>Components and Hardware Needed:</b>	<b>Qty</b>
Dust Ports.....	2
Phillips Head Screws 1/4"-20 x 3/8".....	4
Flat Washers 1/4".....	4
Hinge Pins.....	2

**Tools Needed:**

Phillips Head Screwdriver #2 .....	1
------------------------------------	---

**To mount dust ports:**

1. Align rear dust port holes with tapped holes on back of sander.
2. Insert Phillips head screws and washers through aligned holes and tighten (see **Figure 8**).

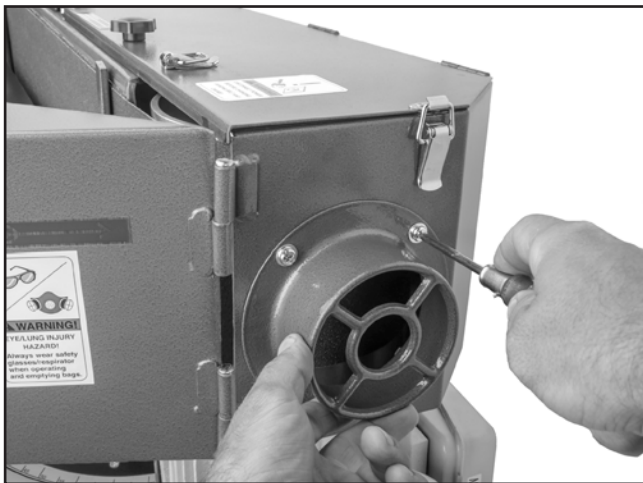
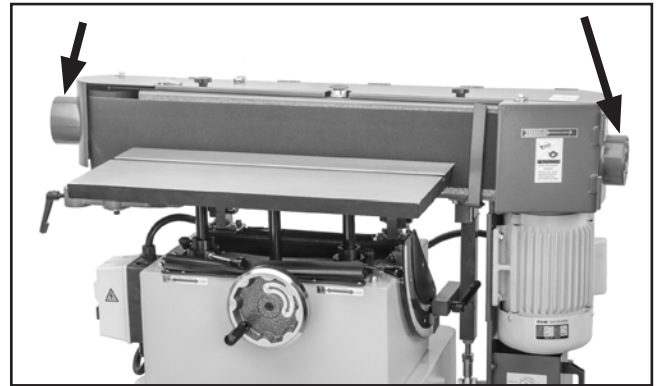

**Figure 8.** Installing dust port.

3. Align hinges of front dust port with hinges on front of sander.
4. Mount front dust port using hinge pins and latches in a similar fashion to dust port cover. (Refer to **Dust Port Cover** on this page.)

# Dust Collection

There are two 4" dust collection ports for the sander that should be connected to a dust collector. The port locations are shown in **Figure 9**.



**Figure 9.** G0563/G0564 dust ports.

<b>Components and Hardware Needed:</b>	<b>Qty</b>
Dust Collector.....	1
Dust Hoses 4".....	2
Hose Clamps 4".....	4

**Tools Needed**

Phillips Head Screwdriver #2 .....	1
------------------------------------	---

**To connect your machine to a dust collection system:**

1. Use 4" diameter hose and clamps to connect a dust collection system to your dust ports.

Model T10116 (**Figure 10**) can be purchased separately through our catalog or online for added dust collection when spindle sanding.



**Figure 10.** Model T10116 auxiliary dust table.



# Test Run

Once assembly is complete, test run the machine to ensure it is properly connected to power and safety components are functioning correctly.

If you find an unusual problem during the test run, immediately stop the machine, disconnect it from power, and fix the problem BEFORE operating the machine again. The **Troubleshooting** table in the **SERVICE** section of this manual can help.

## WARNING

Serious injury or death can result from using this machine BEFORE understanding its controls and related safety information. DO NOT operate, or allow others to operate, machine until the information is understood.

## WARNING

DO NOT start machine until all preceding setup instructions have been performed. Operating an improperly set up machine may result in malfunction or unexpected results that can lead to serious injury, death, or machine/property damage.

### To test run machine:

1. Clear all setup tools away from machine.
2. Connect machine to power supply.
3. Turn machine **ON**. Verify motor operation, and then turn machine **OFF**. The motor should run smoothly and without unusual problems or noises.

4. Turn machine **ON**. Press Emergency Stop Button, shown in **Figure 11**.

—If the machine *stops*, the EMERGENCY STOP button is working properly. Congratulations! The Test Run is complete.

—If the machine *does not stop*, immediately disconnect power to the machine. The EMERGENCY STOP button is not working properly. This safety feature must work correctly before proceeding with regular operations. Call Tech Support for help.

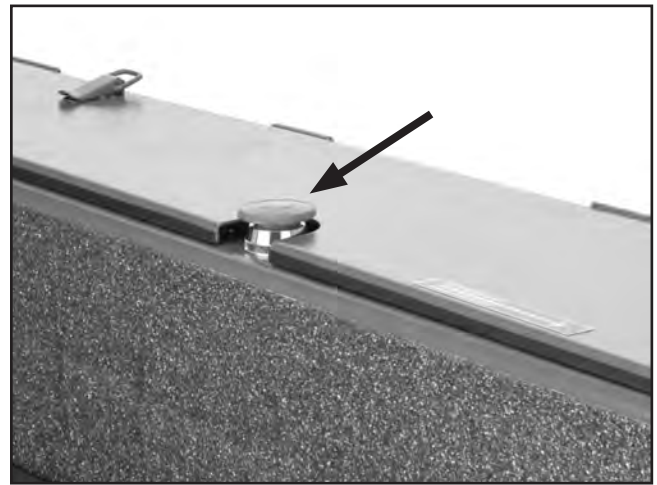

Figure 11. Emergency stop button.



# SECTION 4: OPERATIONS

## ⚠️ WARNING

Damage to your eyes, lungs, and hearing could result from using this machine without proper protective gear. Always wear safety glasses, a respirator, and hearing protection when operating this machine.

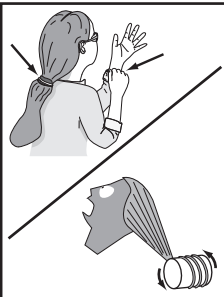
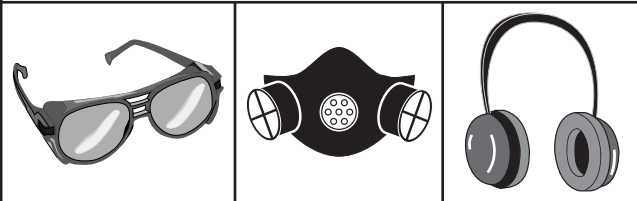

## ⚠️ WARNING

Keep hair, clothing, and jewelry away from moving parts at all times. Entanglement can result in death, amputation, or severe crushing injuries!

## Sanding Belts

There are many types of sanding belts to choose from. We recommend aluminum oxide for general workshop environments. Below is a chart that groups abrasives into different classes and shows which grits fall into each class.

Grit	Type
24–36	Very Coarse
40–60	Coarse
80–100	Medium
120–180	Fine
220–360	Very Fine

The general rule is to sand a workpiece with progressively higher grits. Refer to **Accessories** on **Page 28** for replacement sanding belts.

## Emergency Stop Button

The Model G0563/G0564 is equipped with an emergency stop button on top of the sander. Should an emergency occur during use of the sander, immediately press the emergency stop button. See **Figure 12** for emergency stop button location.

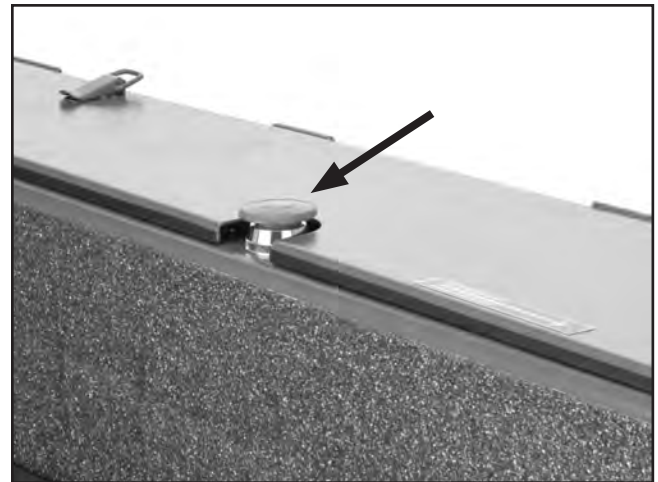

Figure 12. Emergency stop button.

## ⚠️ WARNING

Never use the Model G0563/G0564 for applications other than those for which it was made. **DO NOT** overload the machine or use excess force when sanding. Severe personal injury, damage to the machine, or damage to your workpiece could occur.



# Installing Belt

Components and Hardware Needed:	Qty
Sanding Belt .....	1

## To install belt:

1. Open belt access door by removing the star knobs and opening all latches.
2. Lift belt tensioning lever, as shown in **Figure 13**.



**Figure 13.** Belt tensioning lever in released position.

3. Determine belt direction from the arrows on dust port and access door.
4. Match arrows on sander to arrows inside sanding belt. Place and center belt on sanding drums.
5. Tension sanding belt by pushing belt tensioning lever down.
6. Close belt access door, insert the star knobs, and latch levers.
7. Adjust belt tracking as described on **Page 19**.

# Belt Tracking

After sanding belt has been installed or replaced, or used for a significant amount of time it is necessary to adjust the sanding belt tracking.

## **⚠**WARNING

**DO NOT attempt to perform any adjustments to the sanding belt while the machine is connected to a power source. Failure to unplug before adjusting the sanding belt could result in serious personal injury.**

## Tools Needed:

Hex Wrench 12mm .....	1
-----------------------	---

## To adjust sanding belt tracking:

1. Turn machine **ON** long enough to observe tracking of the sanding belt, then turn machine **OFF**.
2. If sanding belt does not track on a centered path across the rollers, adjustment is necessary.
3. **Disconnect machine from power source!**
4. Loosen the jam nut shown in **Figure 14**.

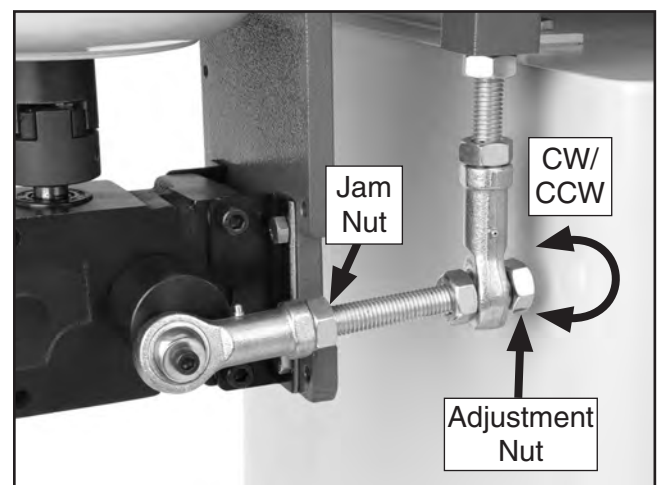

**Figure 14.** Check and adjustment nuts.





5. Determine if sanding belt is tracking too high, or too low:
  - If belt tracks above center, turn adjustment nut, shown in **Figure 14**, counterclockwise.
  - If sanding belt tracks below center, turn adjustment nut clockwise.
6. Tighten jam nut.
7. Connect machine to power and turn **ON**. Observe belt tracking behavior:
  - If belt is tracking correctly, no further adjustment is necessary.
  - If belt is not tracking correctly, repeat **Steps 3–7**.

## Platen Angle Adjustment

The sanding angle of the oscillating edge sander is variable between 0 and 90 degrees.

### To adjust platen angle:

1. Loosen angle adjustment lock handle and tilt sander until the pointer is aligned with desired angle, as shown in **Figure 15**.

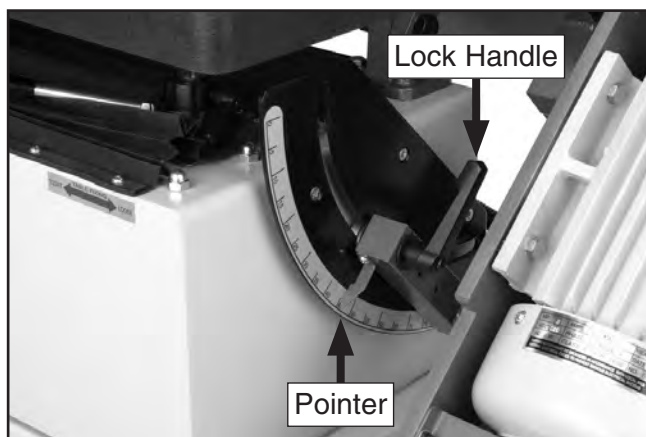

**Figure 15.** Adjusted sanding angle.

2. Tighten angle adjustment lock handle.

Note—Refer to **Page 32** to calibrate angle scale.



## Table Adjustment

The table on the oscillating edge sander moves both vertically and horizontally to accommodate various workpieces shapes and thicknesses. Adjust table height periodically to reduce spot wear of your sanding belt.

### To vertically adjust table:

1. Loosen the lock handles that secure table height position.
2. Turn table height adjustment wheel shown in **Figure 16**, clockwise to raise table or counterclockwise to lower table.

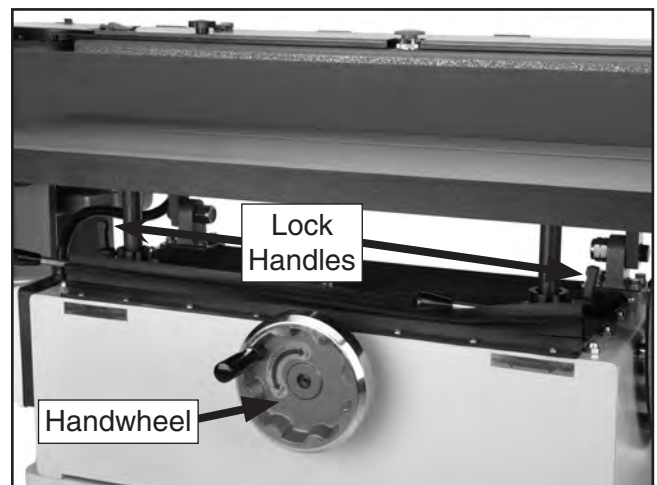

**Figure 16.** Height adjustment controls.

3. When desired position is achieved, tighten the lock handles to secure table height.

*Continued on next page* →

## To horizontally adjust table:

1. Move table lock levers to the loose position, as illustrated by labels on machine.
2. Push or pull table until there is a gap of no more than  $\frac{1}{16}$ " from sanding belt, as shown in **Figure 17**.

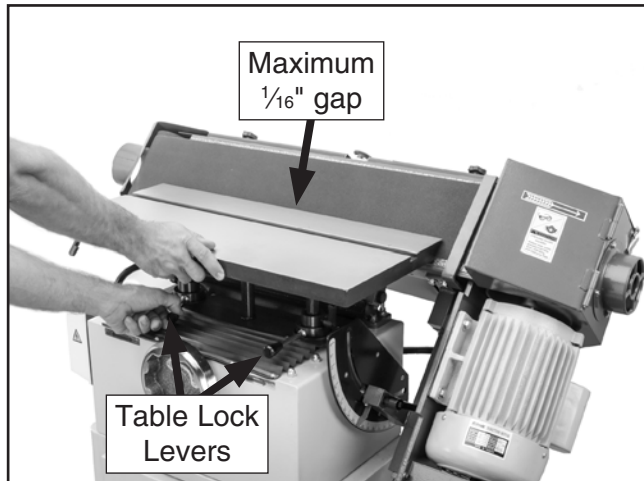

**Figure 17.** Horizontal table adjustment.

3. Move table lock levers to the locked position to secure table position.

# Miter Gauge

The miter gauge needs to be adjusted perpendicular to the face of the belt when it is mounted in the table slot.

## To adjust miter gauge:

1. Use a machinist square with one edge against face of miter gauge and the other against belt face, as shown in **Figure 18**.

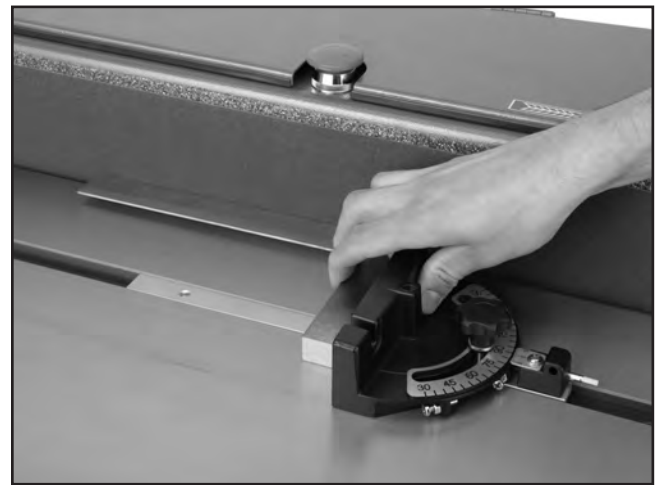

**Figure 18.** Squaring miter gauge to belt.

2. Loosen lock knob on miter gauge to adjust it flush with edge of the square.
3. Tighten lock knob, and verify the setting. *Note—Sometimes the tightening procedure can affect adjustment.*
4. Loosen the screw that secures the angle pointer and adjust pointer to the  $0^\circ$  mark on scale.
5. Retighten screw that secures the angle pointer.



# Sanding Spindle

The Model G0563/G0564 comes with a spindle sanding attachment for sanding curved surfaces. The included sanding drums measure 1½", 2", and 3" in diameter. Be sure to periodically adjust table height to minimize spot wear on the spindle/belt.

<b>Components and Hardware Needed:</b>	<b>Qty</b>
Spindle .....	1
Spindle Washer 5/16" .....	1
Hex Bolt 5/16"-18 x 1/2" .....	1
Spindle Table Assembly .....	1
Lock Handle .....	1
Sanding Drum (dia. of choice) .....	1
Table Insert (dia. of choice) .....	1

### Tools Needed:

Open-End Wrench 10 x 12mm .....	1
Hex Wrench 5mm .....	1
Phillips Head Screwdriver .....	1
Rod (included) .....	1

### To install sanding spindle:

1. Release the belt guard latch, open cover, and latch cover to the belt access door.
2. Remove the three cap screws and false cover from the drum.
3. Line up the screw holes and place the spindle into the drum.
4. Thread cap screws removed in **Step 2** into drum and tighten, as shown in **Figure 19**.



**Figure 19.** Tightening cap screws.

5. Slide sanding drum onto spindle, and insert spindle washer and hex bolt into top of spindle.
6. Insert rod into hole in base of spindle to anchor it, and tighten hex bolt, as shown in **Figure 20**.

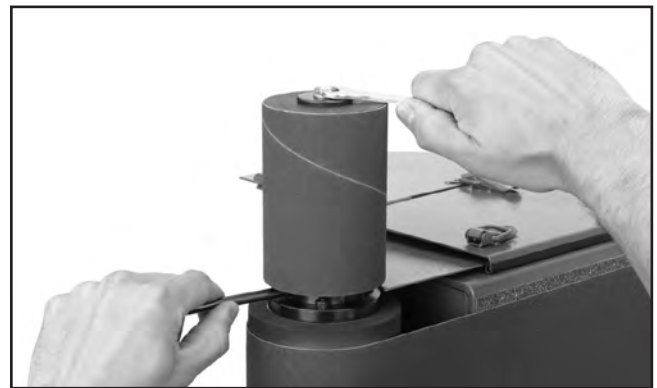

**Figure 20.** Using included rod to anchor spindle.

7. Insert spindle table assembly shaft into opening in idler roller bracket (see **Figure 21**).

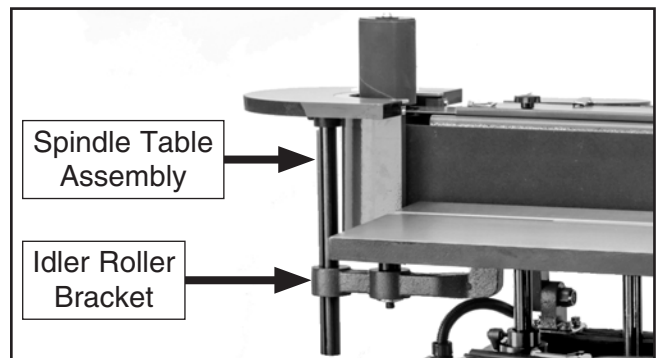

**Figure 21.** Spindle table assembly installed.

8. Thread table lock handle into pre-tapped hole in idler roller bracket. Note—the *handle is spring loaded and can be used as a ratchet*.
9. Remove 4" table insert by removing three flat head screws in the insert.
10. Replace with table insert that matches sanding drum diameter. Tighten with flat head screws removed in **Step 9**.



# Spindle Table Height

The spindle table on the oscillating edge sander can be moved vertically to accommodate various sanding operations and to decrease spot wear on the sanding drums.



To adjust spindle table height:

1. Loosen the adjustment lock handle shown in **Figure 22**.

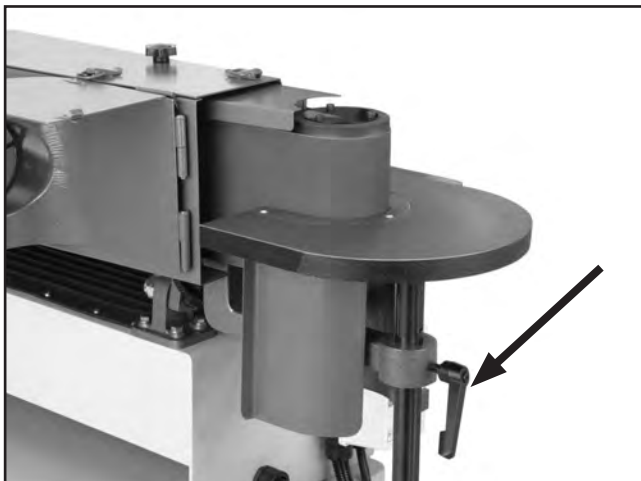

**Figure 22.** Spindle table adjustment lock handle.

2. Raise or lower spindle table to desired height.
3. Tighten the adjustment lock handle.

# Spindle Sanding

The spindle sander on the Model G0563/G0564 produces a high quality sanding finish on inside contours.

## WARNING

Do not use the spindle sanding attachment without the spindle table properly installed and the correct table insert for the drum in place. Failure to do so could result in serious personal injury.

To perform spindle sanding operations:

1. Make sure that appropriate spindle and table insert have been installed correctly and that both are secured tightly.
2. Position table in desired location and turn sander **ON**.
3. While securely holding the workpiece, lightly press it against the spindle and maintain consistent pressure against table, as shown in **Figure 23**. Use extra caution when sanding end-grain.

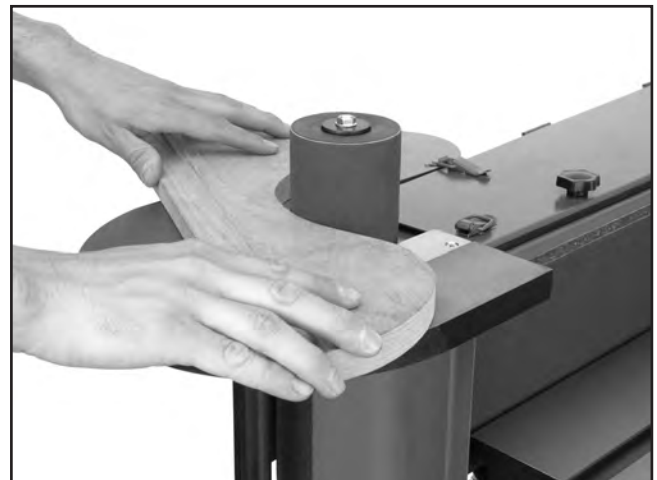

**Figure 23.** Spindle sanding.

4. When you have completed your sanding operation, turn sander **OFF**.



# Edge & End Sanding

Proper use of the oscillating edge sander will yield excellent sanding results due to the oscillating movement.

## CAUTION

If you must feed a workpiece into the sanding belt corner first, feed the trailing corner first. Feeding the leading corner first could cause the sanding belt to grab the workpiece and jerk it out of your hands.

### To perform an edge or end sanding operation:

1. Start sander by turning sander **ON**.
2. Support the workpiece against the back stop, and slowly feed workpiece into moving belt, as shown in **Figure 24**.

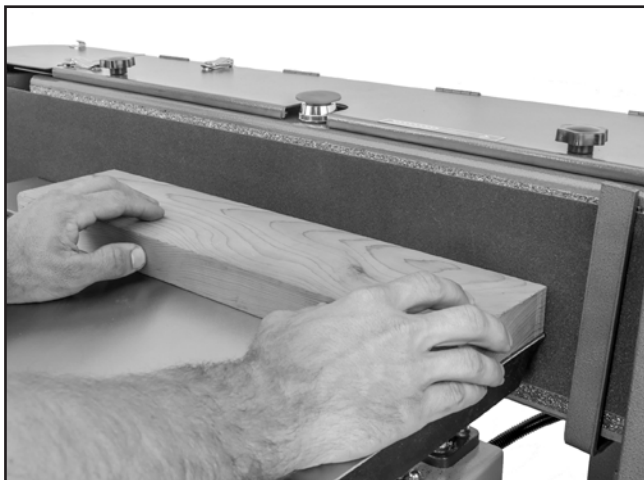

**Figure 24.** Typical edge sanding operation.

3. When you have completed your sanding operation, turn power sander **OFF**.

# Fence

The Model G0563/G0564 comes with a removable fence to assist sanding operations when table is in the horizontal position.

Components and Hardware Needed:	Qty
Fence.....	1
Star Knob .....	2
Flat Washer <sup>5</sup> / <sub>16</sub> " .....	2

### To mount fence:

1. Set fence on table and align the slots with the threaded holes in table.
2. Thread the star knobs and flat washers into the threaded table holes (**Figure 25**) and tighten.



**Figure 25.** Fence installed.



# SECTION 5: ACCESSORIES

## **!WARNING**

Installing unapproved accessories may cause machine to malfunction, resulting in serious personal injury or machine damage. To reduce this risk, only install accessories recommended for this machine by Grizzly.

## **NOTICE**

Refer to our website or latest catalog for additional recommended accessories.

H5445—1½" x 4½", 60 Grit, Hard Sleeve  
H5446—1½" x 4½", 80 Grit, Hard Sleeve  
H5447—1½" x 4½", 100 Grit, Hard Sleeve  
H5448—1½" x 4½", 120 Grit, Hard Sleeve  
H5449—1½" x 4½", 150 Grit, Hard Sleeve  
H5450—2 x 4½", 60 Grit, Hard Sleeve  
H5451—2 x 4½", 80 Grit, Hard Sleeve  
H5452—2 x 4½", 100 Grit, Hard Sleeve  
H5453—2 x 4½", 120 Grit, Hard Sleeve  
H5454—2 x 4½", 150 Grit, Hard Sleeve  
H5455—3 x 4½", 60 Grit, Hard Sleeve  
H5456—3 x 4½", 80 Grit, Hard Sleeve  
H5457—3 x 4½", 100 Grit, Hard Sleeve  
H5458—3 x 4½", 120 Grit, Hard Sleeve  
H5459—3 x 4½", 150 Grit, Hard Sleeve  
H3757—6"W x 108"L, 60 Grit, Sanding Belt  
H3758—6"W x 108"L, 80 Grit, Sanding Belt  
H3759—6"W x 108"L, 100 Grit, Sanding Belt  
H3760—6"W x 108"L, 120 Grit, Sanding Belt  
H3761—6"W x 108"L, 150 Grit, Sanding Belt  
H6881—6"W x 89"L, 60 Grit, Sanding Belt  
H6882—6"W x 89"L, 80 Grit, Sanding Belt  
H6883—6"W x 89"L, 100 Grit, Sanding Belt  
H6884—6"W x 89"L, 120 Grit, Sanding Belt  
H6885—6"W x 89"L, 150 Grit, Sanding Belt  
Grizzly Industrial offers a full selection of replacement sanding belts and sleeves for your Model G0563/G0564. Increase the versatility and overall results from your machine by keeping a full range of grits and using the best choice for each application.

W1304—Pro-Stik Belt Cleaner 1⅜" x 4¼"  
W1305—Pro-Stik Belt Cleaner 1⅜" x 8½"  
W1306—Pro-Stik Belt Cleaner 1½" x 1½" x 8½"  
W1307—Pro-Stik Belt Cleaner 2" x 2" x 12"

These crepe-rubber belt cleaners quickly remove gum and grit from belts and discs without damage. Just press the cleaning block against your sanding belt or disc until it is clean.



Figure 26. Pro-Stik Belt Cleaners.

D2057A—Heavy-Duty Mobile Base  
D2058A—Super Heavy-Duty Mobile Base

The most stable mobile bases on the market with heavy-duty casters arranged on outriggers for low center of gravity. The D2057A has a weight capacity of 700 lbs. and the D2058A handles up to 1,300 lbs.

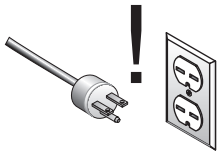

Figure 27. D2057A Heavy-Duty Mobile Base.

**order online at [www.grizzly.com](http://www.grizzly.com) or call 1-800-523-4777**



# SECTION 6: MAINTENANCE



**⚠️ WARNING**  
Always disconnect power to the machine before performing service adjustments. Failure to do this may result in serious personal injury.

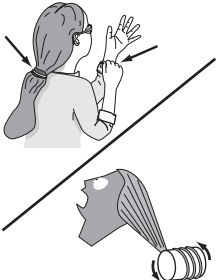

**⚠️ WARNING**  
Keep hair, clothing, and jewelry away from moving parts at all times. Entanglement can result in death, amputation, or severe crushing injuries!



**⚠️ WARNING**  
Wear safety glasses during the entire maintenance process. Failure to comply may result in serious personal injury

## General

Regular periodic maintenance of your Model G0563/G0564 will ensure optimum performance. Make a habit of inspecting your machine each time you use it. Check for the following conditions and repair or replace when necessary:

1. Loose mounting bolts.
2. Worn switch.
3. Worn or damaged cords and plugs.
4. Damaged or worn sanding belt.
5. Any other condition that could hamper the safe operation of this machine.

## Lubrication

After operating the Model G0563/G0564 for approximately 500 hours, refill the gearbox with oil.

### Tools Needed:

Wrench 10 x 12mm Open-End.....	1
Hex Wrench 5mm.....	1
Grease Gun w/All Purpose Grease .....	1
Oil Can w/Light Machine Oil.....	1
SAE 80W Gear Oil .....	1

### To check and refill gearbox:

1. Place belt sander in the horizontal position.
2. Remove the cap screws on top of the gearbox cover shown in **Figure 28**.

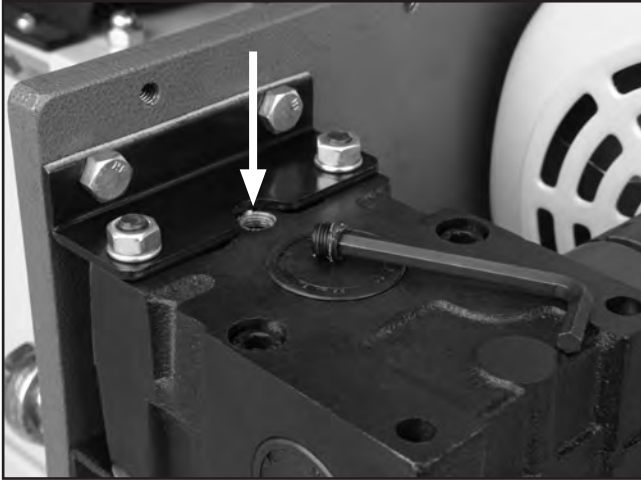

**Figure 28.** Gearbox cap screws.

3. Remove the hex bolts on opposite side of gearbox and remove the gearbox cover.



- Remove the oil fill plug on top of the gearbox, as shown in **Figure 29** and fill with SAE 80W gear oil until the level is 1/2" from the top.



**Figure 29.** Oil fill hole and screw.

- Re-install gearbox cover with hex bolts and cap screws.

#### **Rack and Pinion Gear**

The rack and pinion gear that moves the table vertically should be greased well to maintain smooth operation.

#### **To grease rack and pinion gear:**

- With table in its lowest position, wipe the rack and pinion with a rag to remove buildup of sawdust and old grease.
- Apply a coat of all purpose grease to the rack and pinion gears.

#### **Grease Fittings and Oil Ports**

There are two oil ports shown in **Figure 30** and four grease fittings shown in **Figure 31**. Lubricate these points after approximately 50 hours of use with light machine oil.

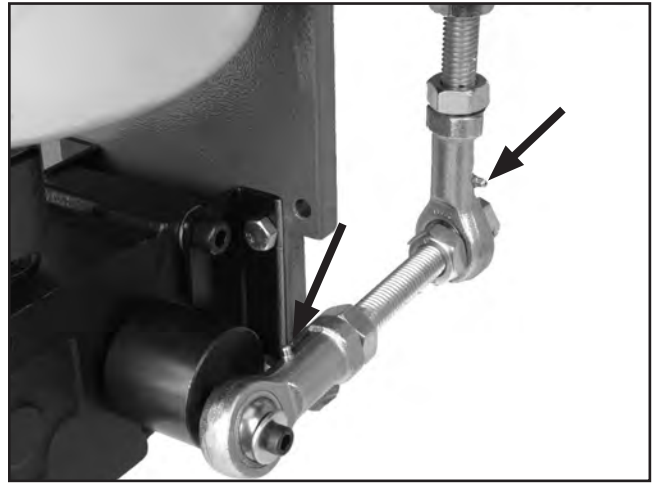

**Figure 30.** Oil ports on oscillating assembly.



**Figure 31.** Grease fittings inside sanding body.

All other bearings on the Model G0563/G0564 are sealed and permanently lubricated, so there is no need to lubricate them.





# Tables

The tables of the Model G0563/G0564 can be kept rust-free with regular applications of products like G96® Gun Treatment, SLIPIT®, or Boeshield® T-9 (see **Accessories** on **Page 28** for more details).

## Spindle Connector

The spindle connector connects the shafts from the motor to the gearbox and is secured by two set screws that need to be tightened every time the gearbox oil is filled (every 500 hours).

### Tools Needed:

Hex Wrench 5mm.....	1
Hex Wrench 4mm.....	1
Open End Wrench 10 x 12mm .....	1

### To secure spindle connector set screws:

1. Refer to **Lubrication Steps 1–3** on **Page 29** to remove gearbox cover.
2. Tighten set screws shown in **Figure 32**.

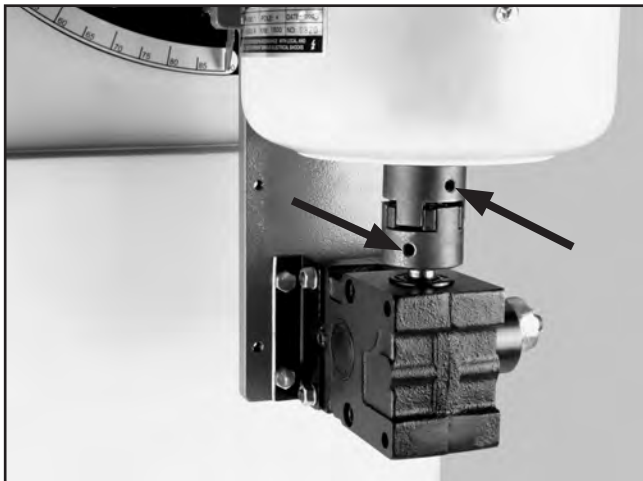

**Figure 32.** Spindle connector set screws.

3. Re-install gearbox cover.

# Eccentric

The eccentric on the Model G0563/G0564 is connected to the shaft by a set screw. This set screw needs to be tightened every time the gearbox oil is filled (every 500 hours).

### Tools Needed:

Hex Wrench 5mm.....	1
Hex Wrench 4mm.....	1
Open End Wrench 10 x 12mm .....	1

### To secure eccentric set screw:

1. Refer to **Lubrication Steps 1–3** on **Page 29** to remove the gearbox cover.
2. Tighten set screw on the eccentric shown in **Figure 33**.

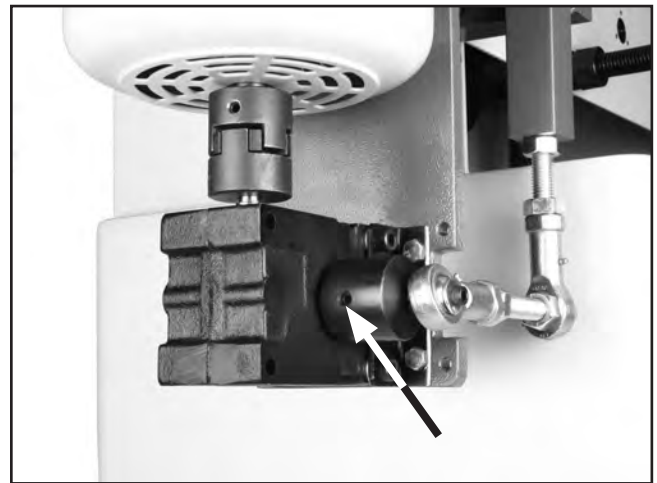

**Figure 33.** Eccentric set screw.

3. Re-install gearbox cover.



# SECTION 7: SERVICE

Review the troubleshooting and procedures in this section if a problem develops with your machine. If you need replacement parts or additional help with a procedure, call our Technical Support. **Note:** Please gather the serial number and manufacture date of your machine before calling.

## Troubleshooting Machine

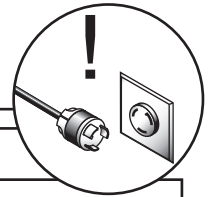

SYMPTOM	POSSIBLE CAUSE	CORRECTIVE ACTION
Motor will not start.	<ol style="list-style-type: none"> <li>1. Low voltage.</li> <li>2. Open circuit in motor or loose connections.</li> </ol>	<ol style="list-style-type: none"> <li>1. Check power line for proper voltage.</li> <li>2. Inspect all lead connections on motor for loose or open connections.</li> </ol>
Motor will not start; fuses or circuit breakers blow.	<ol style="list-style-type: none"> <li>1. Short circuit in line cord or plug.</li> <li>2. Short circuit in motor or loose connections.</li> <li>3. Incorrect fuses or circuit breakers in power line.</li> </ol>	<ol style="list-style-type: none"> <li>1. Inspect cord or plug for damaged insulation and shorted wires.</li> <li>2. Inspect all connections on motor for loose or shorted terminals or worn insulation.</li> <li>3. Install correct fuses or circuit breakers.</li> </ol>
Motor overheats.	<ol style="list-style-type: none"> <li>1. Motor overloaded.</li> <li>2. Air circulation through the motor restricted.</li> </ol>	<ol style="list-style-type: none"> <li>1. Reduce load on motor.</li> <li>2. Clean out motor to provide normal air circulation.</li> </ol>
Motor stalls (resulting in blown fuses or tripped circuit).	<ol style="list-style-type: none"> <li>1. Short circuit in motor or loose connections.</li> <li>2. Low voltage.</li> <li>3. Incorrect fuses or circuit breakers in power line.</li> <li>4. Motor overloaded.</li> </ol>	<ol style="list-style-type: none"> <li>1. Inspect connections on motor for loose or shorted terminals or worn insulation.</li> <li>2. Correct the low voltage conditions.</li> <li>3. Install correct fuses or circuit breakers.</li> <li>4. Reduce load on motor.</li> </ol>
Machine slows when operating.	<ol style="list-style-type: none"> <li>1. Applying too much pressure to workpiece.</li> <li>2. Undersized circuit or using ext cord.</li> <li>3. Run capacitor is a fault.</li> </ol>	<ol style="list-style-type: none"> <li>1. Sand with less pressure—let the movement of the belt do the work.</li> <li>2. Make sure circuit wires are proper gauge &amp; don't use extension cords!</li> <li>3. Replace run capacitor.</li> </ol>
Loud, repetitious noise coming from machine.	<ol style="list-style-type: none"> <li>1. Main drive roller hex nut is missing or loose.</li> <li>2. Motor fan is hitting the cover.</li> </ol>	<ol style="list-style-type: none"> <li>1. Inspect keys and setscrews. Replace or tighten if necessary.</li> <li>2. Tighten fan or shim cover.</li> </ol>
Machine vibrates excessively.	<ol style="list-style-type: none"> <li>1. Stand not stable on floor.</li> <li>2. Loose motor mounting.</li> <li>3. Weak or broken tension spring.</li> <li>4. Idler roller is too loose.</li> <li>5. Broken/defective sanding belt.</li> </ol>	<ol style="list-style-type: none"> <li>1. Secure stand to floor, reposition to level surface, or shim stand.</li> <li>2. Check/tighten motor mounting.</li> <li>3. Replace spring.</li> <li>4. Adjust idler roller.</li> <li>5. Replace sanding belt.</li> </ol>

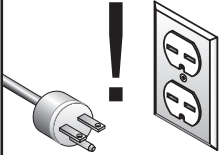

**⚠ WARNING**  
**Disconnect power to the machine when performing any troubleshooting. Failure to do this may result in serious personal injury**



# Troubleshooting Sanding

SYMPTOM	POSSIBLE CAUSE	CORRECTIVE ACTION
Deep sanding grooves or marks in workpiece.	<ol style="list-style-type: none"> <li>1. Sanding belt grit too coarse for the desired finish.</li> <li>2. Workpiece is being sanded across the grain.</li> <li>3. Too much sanding force on workpiece.</li> <li>4. Workpiece held still against the belt.</li> </ol>	<ol style="list-style-type: none"> <li>1. Use a finer grit sanding belt.</li> <li>2. Sand with the grain.</li> <li>3. Reduce pressure on workpiece while sanding.</li> <li>4. Keep workpiece moving while sanding on the belt.</li> </ol>
Grains easily rub off the belt.	<ol style="list-style-type: none"> <li>1. Sanding belt has been stored in an incorrect environment.</li> <li>2. Sanding belt has been folded or smashed.</li> </ol>	<ol style="list-style-type: none"> <li>1. Store sanding belt away from extremely dry or hot temperatures.</li> <li>2. Hang sanding belt or store unfolded and unstacked.</li> </ol>
Glazed sanding belt.	<ol style="list-style-type: none"> <li>1. Sanding wet stock.</li> <li>2. Sanding stock with high residue.</li> </ol>	<ol style="list-style-type: none"> <li>1. Dry stock properly before sanding.</li> <li>2. Use different stock. Or, accept the characteristics of the stock and plan on cleaning/replacing belts frequently.</li> </ol>
Burn marks on workpiece.	<ol style="list-style-type: none"> <li>1. Using too fine of sanding belt grit.</li> <li>2. Using too much pressure against belt.</li> <li>3. Work held still for too long.</li> </ol>	<ol style="list-style-type: none"> <li>1. Use a coarser grit sanding belt.</li> <li>2. Reduce pressure on workpiece while sanding.</li> <li>3. Do not keep workpiece in one place for too long and allow to cool.</li> </ol>
Sanding belt clogs quickly or burns.	<ol style="list-style-type: none"> <li>1. Using too much pressure against belt.</li> <li>2. Sanding softwood.</li> </ol>	<ol style="list-style-type: none"> <li>1. Reduce pressure on workpiece while sanding.</li> <li>2. Use different stock. Or, accept the characteristics of the stock and plan on cleaning/replacing belts frequently with Pro-Stik cleaning pads.</li> </ol>
Workpiece frequently gets pulled out of your hand.	<ol style="list-style-type: none"> <li>1. Not supporting the workpiece against the stop.</li> <li>2. Starting the workpiece on a leading corner.</li> </ol>	<ol style="list-style-type: none"> <li>1. Use back stop to support workpiece.</li> <li>2. Start workpiece on a trailing corner.</li> </ol>
Sanding belt comes off during operation.	<ol style="list-style-type: none"> <li>1. Tracking/Oscillation out of adjustment.</li> </ol>	<ol style="list-style-type: none"> <li>1. Set belt tracking as described in <i>Section: 7 Service Page 32</i>.</li> </ol>

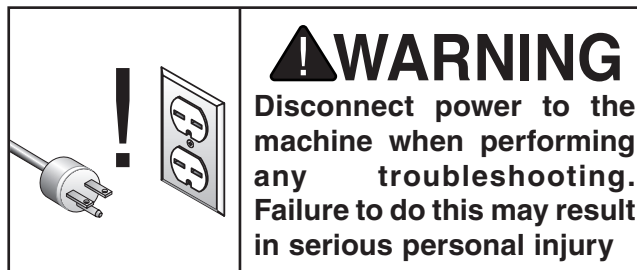

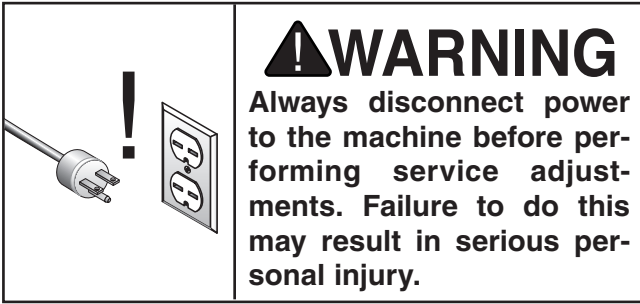

## About Service

This section is designed to help the operator with adjustments that were made at the factory and that may also need to be made during the life of the machine.

This section is provided for your convenience—it is not a substitute for the Grizzly Service Department. If any adjustments arise that are not described in this manual, then feel free to call the Grizzly Service Department at (570) 546-9663.

Similarly, if you are unsure of how to perform any procedure in this section, the Grizzly Service Department will be happy to guide you through the procedures or help in any other way.

# Calibrating Angle Gauge

In order to maintain accuracy and precision with the oscillating edge sander, periodically calibrate the angle gauge.

### Tools Needed:

Machinist's Square ..... 1  
Flat Head Screwdriver ..... 1

### To calibrate angle gauge:

1. Loosen angle adjustment lock handle.
2. Place machinist's square on table and press it against the platen.
3. Adjust platen until it is flush with the machinist's square, as shown in **Figure 34**.

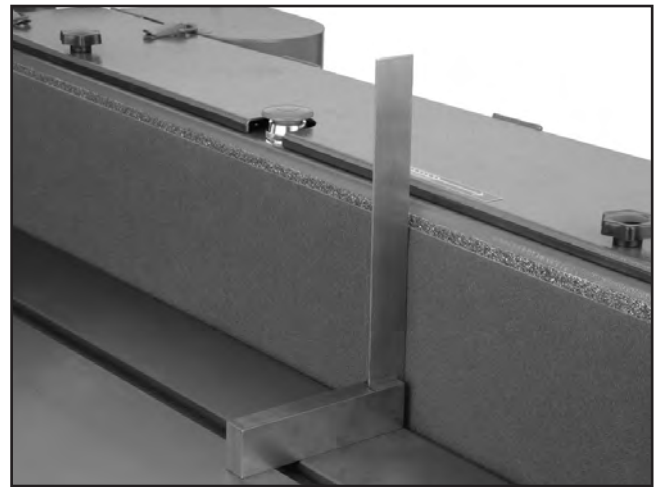
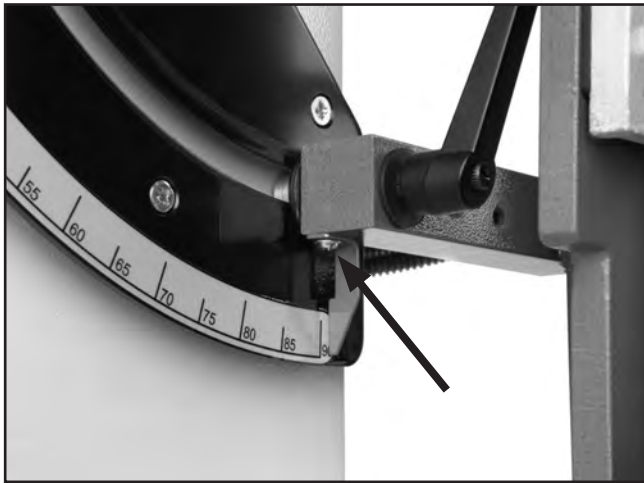

**Figure 34.** Aligning table to platen.

4. Tighten angle adjustment lock handle.



- Loosen angle indicator pin screw, shown in **Figure 35**,  $\frac{1}{2}$  turn.



**Figure 35.** Angle indicator pin screw.

- Align angle indicator pin with the  $90^\circ$  mark and tighten angle indicator pin screw.

## Removing Drive Roller

The Model G0563/G0564 comes equipped with a puller to remove the drive roller should it become necessary to do so.

### Tools Needed:

Cap Screw $\frac{5}{16}$ "-18 x $1\frac{1}{4}$ ".....	1
Cap Screw $\frac{1}{4}$ "-20 x $1\frac{3}{4}$ " .....	2
Drive Puller Plate.....	1
Hex Wrench 5mm.....	1
Hex Wrench 6mm.....	1
Socket $\frac{7}{8}$ " .....	1
Ratchet w/ $6$ " extension.....	1

### To remove drive roller:

- Remove hex nut and lock washer securing driver roller to shaft.
- Thread the two  $\frac{1}{4}$ "-20 x  $1\frac{3}{4}$ " cap screws on the puller four turns into the threaded holes in drive roller.
- Thread and tighten the  $\frac{5}{16}$ "-18 x  $1\frac{1}{4}$ " cap screw on the puller, shown in **Figure 36**, until drive roller is pulled.



**Figure 36.** Using the drive roller puller.

- To re-install, place drive roller on shaft, and thread the lock washer and hex nut onto shaft and tighten securely.

**NOTE—Do not hammer drive roller onto shaft or you will cause damage to the shaft.**



# SECTION 8: WIRING

These pages are current at the time of printing. However, in the spirit of improvement, we may make changes to the electrical systems of future machines. Compare the manufacture date of your machine to the one stated in this manual, and study this section carefully.

If there are differences between your machine and what is shown in this section, call Technical Support at (570) 546-9663 for assistance BEFORE making any changes to the wiring on your machine. An updated wiring diagram may be available. **Note:** *Please gather the serial number and manufacture date of your machine before calling. This information can be found on the main machine label.*

## WARNING

### Wiring Safety Instructions

**SHOCK HAZARD.** Working on wiring that is connected to a power source is extremely dangerous. Touching electrified parts will result in personal injury including but not limited to severe burns, electrocution, or death. Disconnect the power from the machine before servicing electrical components!

**MODIFICATIONS.** Modifying the wiring beyond what is shown in the diagram may lead to unpredictable results, including serious injury or fire. This includes the installation of unapproved after-market parts.

**WIRE CONNECTIONS.** All connections must be tight to prevent wires from loosening during machine operation. Double-check all wires disconnected or connected during any wiring task to ensure tight connections.

**CIRCUIT REQUIREMENTS.** You MUST follow the requirements at the beginning of this manual when connecting your machine to a power source.

**WIRE/COMPONENT DAMAGE.** Damaged wires or components increase the risk of serious personal injury, fire, or machine damage. If you notice that any wires or components are damaged while performing a wiring task, replace those wires or components.

**MOTOR WIRING.** The motor wiring shown in these diagrams is current at the time of printing but may not match your machine. If you find this to be the case, use the wiring diagram inside the motor junction box.















**CAPACITORS/INVERTERS.** Some capacitors and power inverters store an electrical charge for up to 10 minutes after being disconnected from the power source. To reduce the risk of being shocked, wait at least this long before working on capacitors.

**EXPERIENCING DIFFICULTIES.** If you are experiencing difficulties understanding the information included in this section, contact our Technical Support at (570) 546-9663.

#### NOTICE

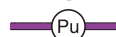
The photos and diagrams included in this section are best viewed in color. You can view these pages in color at [www.grizzly.com](http://www.grizzly.com).

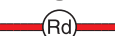
#### COLOR KEY

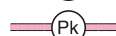
BLACK 	BLUE 	YELLOW 	LIGHT BLUE 
WHITE 	BROWN 	YELLOW GREEN 	BLUE WHITE 
GREEN 	GRAY 	PURPLE 	TURQUOISE 
RED 	ORANGE 	PINK 	



# G0563 Wiring Diagram

**⚠ DANGER**  
 Disconnect power before performing any electrical service. Electricity presents serious shock hazards that will result in severe personal injury and even death!

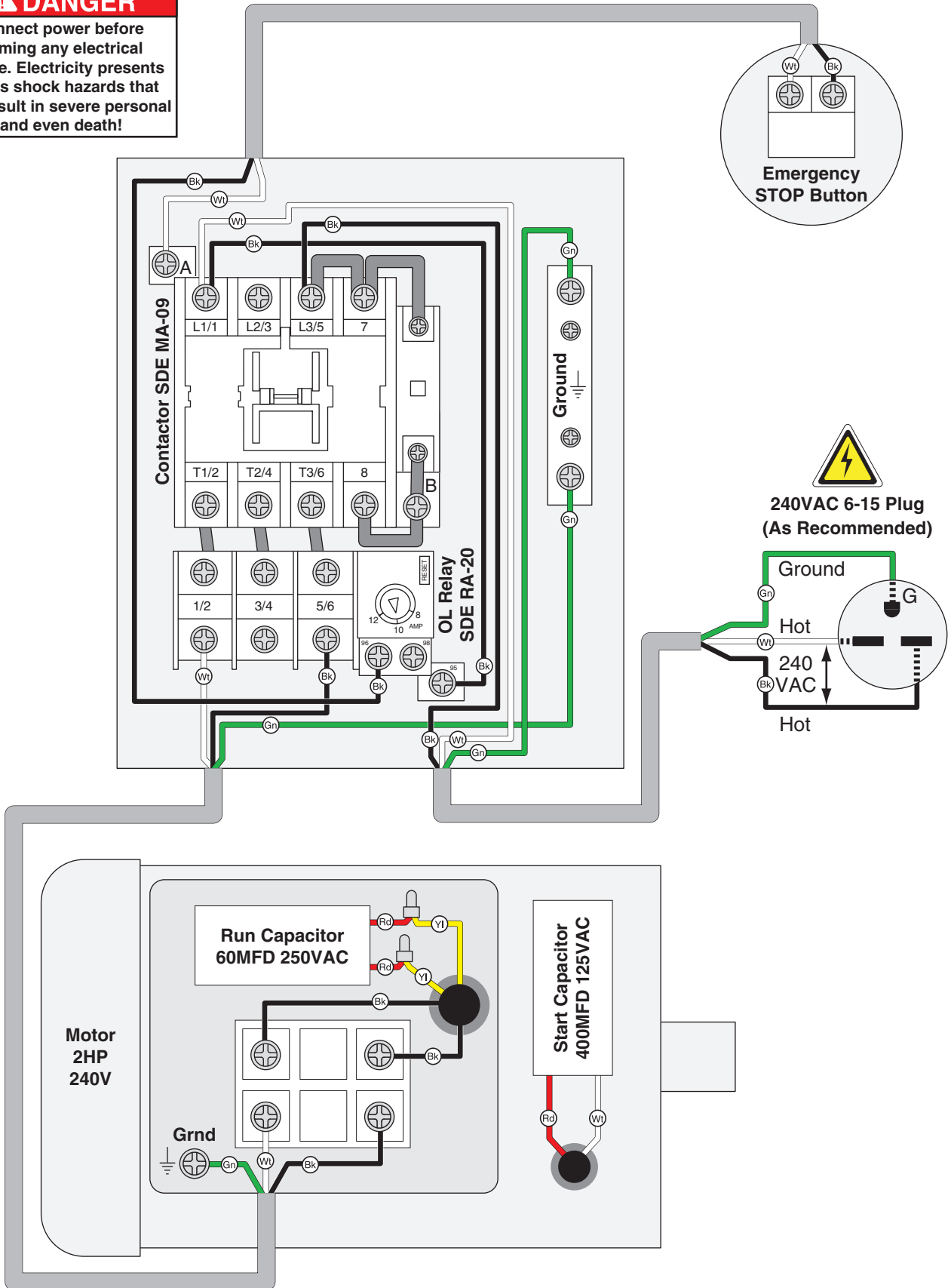

# G0564 Wiring Diagram

**⚠ DANGER**  
 Disconnect power before performing any electrical service. Electricity presents serious shock hazards that will result in severe personal injury and even death!

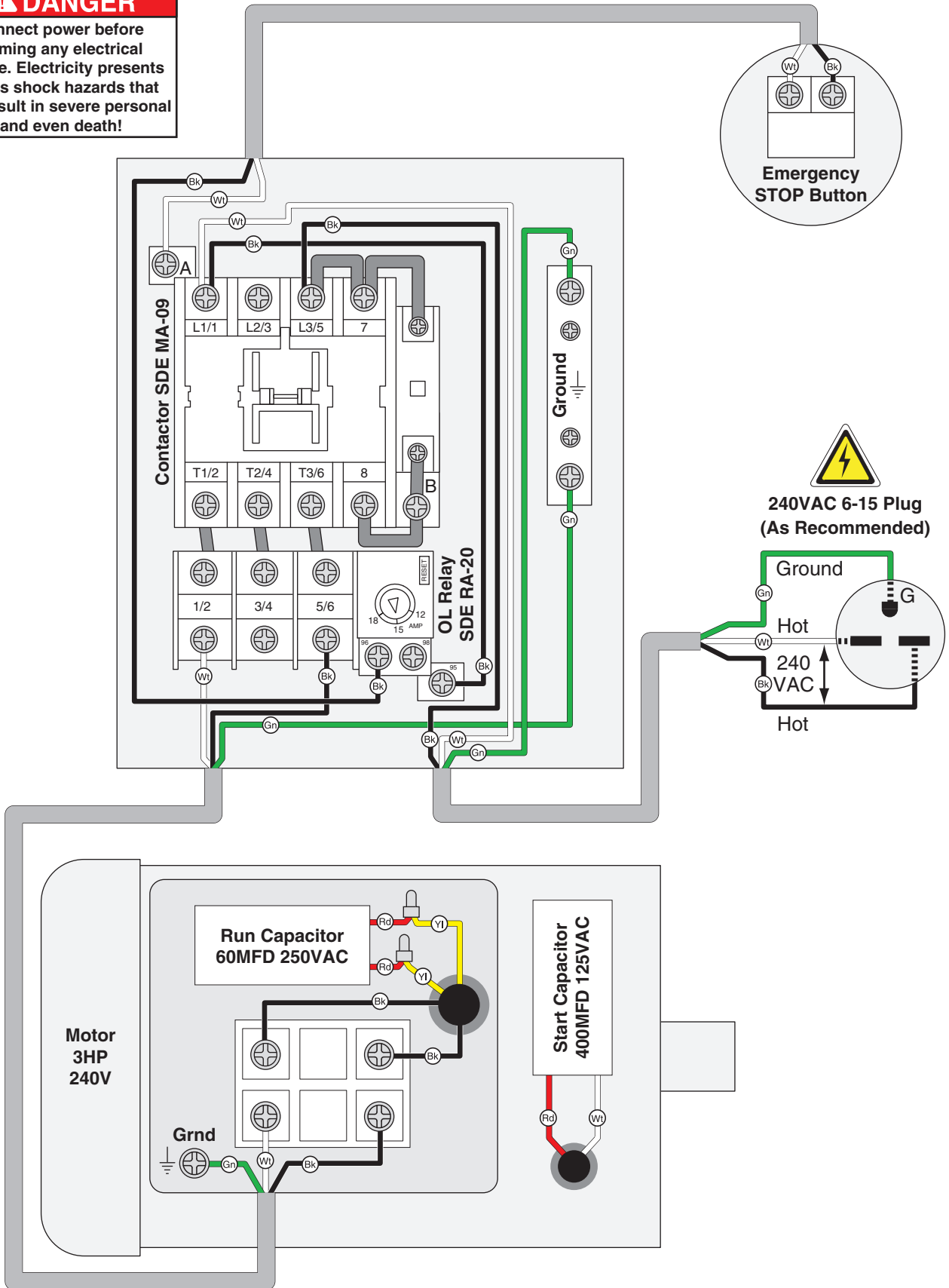



# SECTION 9: PARTS

## G0563 Breakdown

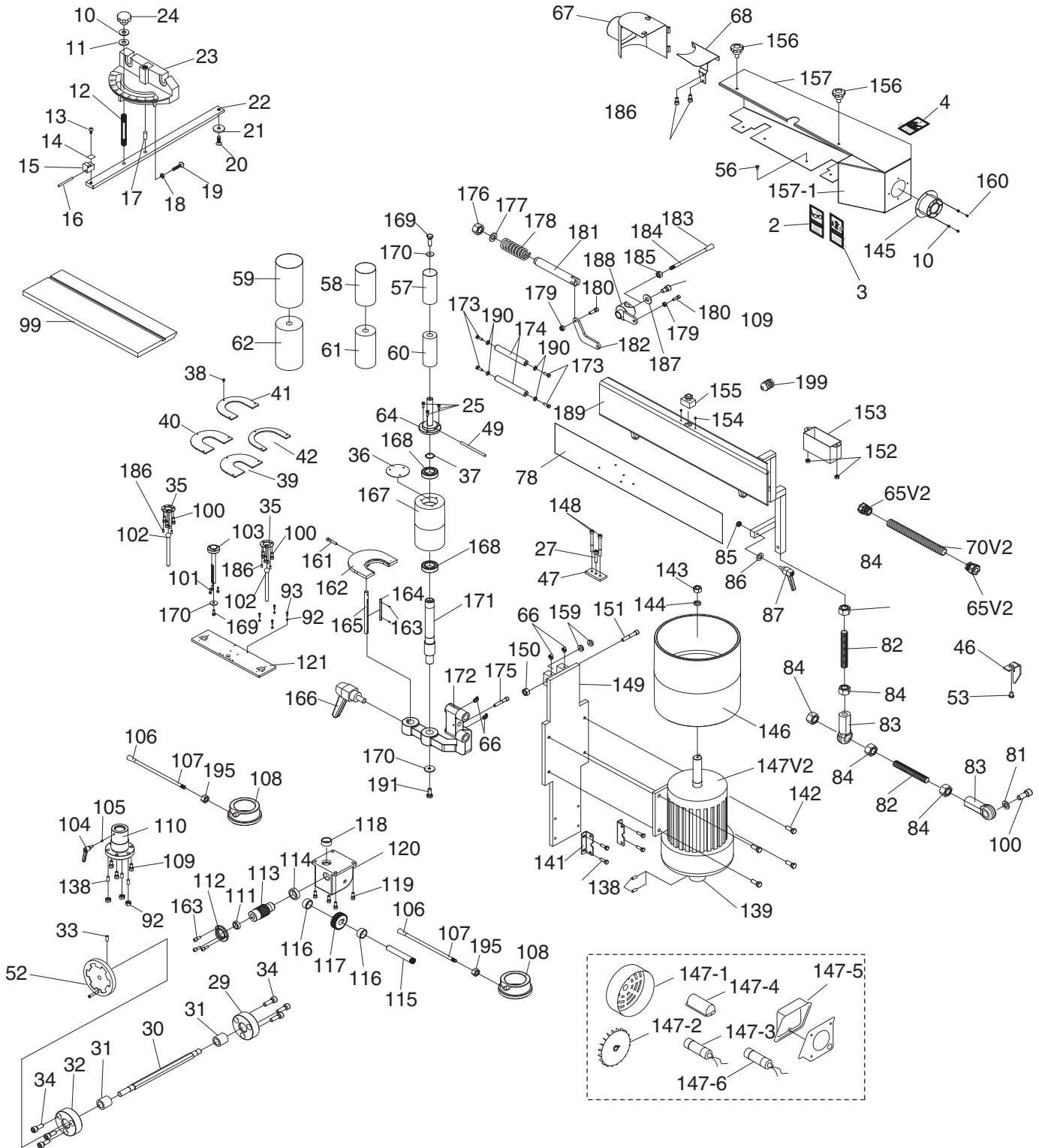

# G0563 Breakdown

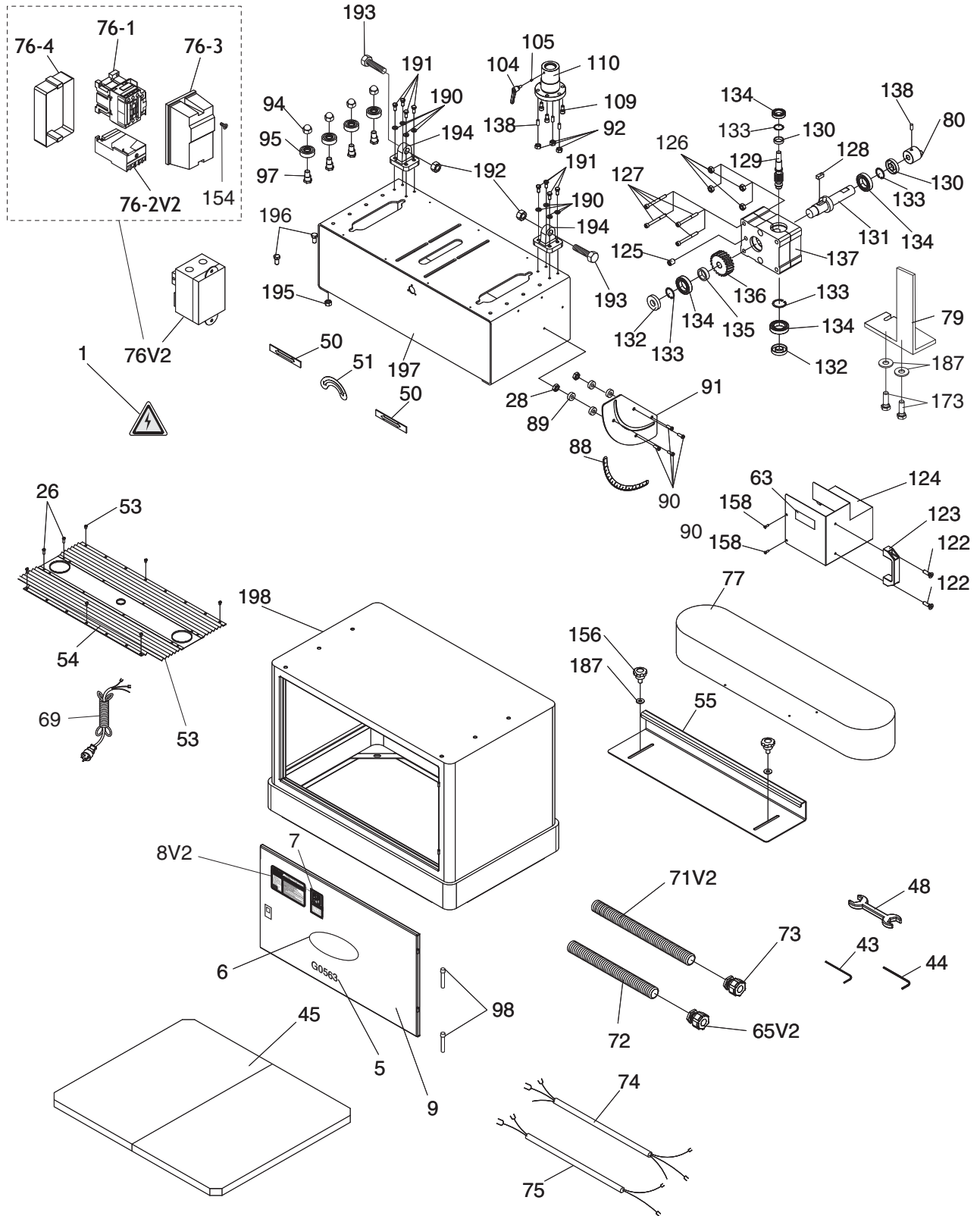

# G0563 Parts List

REF	PART #	DESCRIPTION
1	P0563001	ELECTRICITY LABEL
2	P0563002	SAFETY GLASSES LABEL
3	P0563003	DUST HAZARD LABEL
4	P0563004	DISCONNECT LABEL
5	P0563005	MODEL NUMBER LABEL
6	P0563006	LOGO PLATE
7	P0563007	READ MANUAL LABEL
8V2	P0563008V2	MACHINE ID LABEL CSA V2.10.11
9	P0563009	DOOR W/LATCH
10	P0563010	FLAT WASHER 1/4
11	P0563011	WASHER 1/4 PLASTIC
12	P0563012	STUD 1/4-20 X 1-1/4
13	P0563013	PHLP HD SCR 10-24 X 1/4
14	P0563014	POINTER PLATE
15	P0563015	POINTER BODY
16	P0563016	STOP SHAFT
17	P0563017	PIVOT PIN
18	P0563018	HEX NUT 10-24
19	P0563019	PHLP HD SCR 10-24 X 3/4
20	P0563020	FLAT HD SCR 10-24 X 3/8
21	P0563021	T-SLOT WASHER
22	P0563022	MITER BAR
23	P0563023	MITER GAUGE BODY
24	P0563024	FEMALE KNOB 1/4-20
25	P0563025	CAP SCREW M5-.8 X 16
26	P0563026	PHLP HD SCR 10-24 X 3/4
27	P0563027	CAP SCREW 5/16-18 X 1-1/4
28	P0563028	HEX NUT 1/4-20
29	P0563029	HEX SPINDLE BACK COVER
30	P0563030	HEX SPINDLE
31	P0563031	SLEEVE
32	P0563032	HEX SPINDLE FRONT COVER
33	P0563033	SET SCREW 5/16-18 X 1/2
34	P0563034	CAP SCREW M6-1 X 16
35	P0563035	TABLE MOUNTING BRACKET
36	P0563036	IDLER ROLLER COVER
37	P0563037	EXT RETAINING RING 25MM
38	P0563038	FLAT HD SCR 10-24 X 3/8
39	P0563039	TABLE INSERT 1-1/2
40	P0563040	TABLE INSERT 2-1/2
41	P0563041	TABLE INSERT 3
42	P0563042	TABLE INSERT 4
43	P0563043	HEX WRENCH 5MM
44	P0563044	HEX WRENCH 6MM
45	P0563045	WOOD BOARD 25 X 395 X 457
46	P0563046	POINTER
47	P0563047	PLATE 70 X 31.7 X 5/16
48	P0563048	WRENCH 10 X 12MM OPEN-ENDS
49	P0563049	ROD
50	P0563050	TABLE ADJUSTMENT LABEL
51	P0563051	ROTATION LABEL
52	P0563052	HANDWHEEL
53	P0563053	PHLP HD SCR 10-24 X 3/8

REF	PART #	DESCRIPTION
54	P0563054	EXTENDABLE COVER
55	P0563055	FENCE
56	P0563056	HEX BOLT 1/4-20 X 1/4
57	P0563057	SANDING SLEEVE 1-1/2
58	P0563058	SANDING SLEEVE 2
59	P0563059	SANDING SLEEVE 3
60	P0563060	RUBBER DRUM 1-1/2
61	P0563061	RUBBER DRUM 2
62	P0563062	RUBBER DRUM 3
63	P0563063	ADJUSTMENT LABEL
64	P0563064	SANDING DRUM SPINDLE
65	P0563065	CONDUIT CONNECTOR 1/2" V1
65V2	P0563065V2	CONDUIT CONNECTOR 3/8" V2.09.11
66	P0563066	GREASE FITTING 1/8 30-DEG
67	P0563067	COVER FOR DUST PORT
68	P0563068	GUARD
69	P0563069	POWER CORD
70	P0563070	PLASTIC CONDUIT 1/2" V1
70V2	P0563070V2	PLASTIC CONDUIT 3/8 X 18" V2.09.11
71	P0563071	PLASTIC CONDUIT 1/2" V1
71V2	P0563071V2	PLASTIC CONDUIT 3/8 X 12" V2.09.11
72	P0563072	PLASTIC CONDUIT 3/8 X 11"
73	P0563073	CONDUIT CONNECTOR 3/8
74	P0563074	MOTOR POWER CORD
75	P0563075	EMERGENCY STOP POWER CORD
76V2	P0563076V2	MAGNETIC SWITCH V2.10.11
76-1	P0563076-1	CONTACTOR SDE MA-09 220-240V
76-2V2	P0563076-2V2	OL RELAY SDE RA-20 8-12A V2.10.11
76-3	P0563076-3	MAG SWITCH FRONT COVER
76-4	P0563076-4	MAG SWITCH REAR COVER
77	P0563077	SANDING BELT 6 X 89"
78	P0563078	GRAPHITE PAPER 30-1/4 X 6-3/4
79	P0563079	BACK STOP
80	P0563080	ECCENTRIC
81	P0563081	FLAT WASHER 1/4
82	P0563082	ADJUSTING ROD
83	P0563083	TIE ROD
84	P0563084	HEX NUT M14-2
85	P0563085	PLATEN NUT 3/8-16
86	P0563086	FLAT WASHER 3/8
87	P0563087	HANDLE 3/8-16 X 50
88	P0563088	ANGLE GAUGE LABEL
89	P0563089	MITER GAUGE SPACER
90	P0563090	FLAT HD SCR 1/4-20 X 3/4
91	P0563091	SCALE PLATE
92	P0563092	LOCK NUT 5/16-18
93	P0563093	CARRIAGE BOLT 5/16-18 X 1-1/4
94	P0563094	ACORN NUT 3/8-16
95	P0563095	BALL BEARING 6001ZZ
97	P0563097	ECCENTRIC BOLT
98	P0563098	HINGE PIN 8 X 45MM
99	P0563099	TABLE
100	P0563100	CAP SCREW 5/16-18 X 3/4



# G0563 Parts List

REF	PART #	DESCRIPTION
101	P0563101	HEX BOLT 5/16-18 X 1
102	P0563102	SPINDLE
103	P0563103	RACK GEAR
104	P0563104	HANDLE 1/4 X 1/2
105	P0563105	INSERT 5 X 3 COPPER
106	P0563106	FEMALE KNOB 3/8-16
107	P0563107	HANDLE BAR
108	P0563108	LOCK COLLAR
109	P0563109	CAP SCREW 1/4-20 X 1/2
110	P0563110	SPINDLE SPACER
111	P0563111	BALL BEARING 38 X 42 X 20T
112	P0563112	PACKING
113	P0563113	PINION ROD
114	P0563114	RING COPPER
115	P0563115	PINION SPINDLE
116	P0563116	SPACER
117	P0563117	PINION GEAR
118	P0563118	RING COPPER
119	P0563119	CAP SCREW 5/16-18 X 3/4
120	P0563120	RACK & PINION BOX
121	P0563121	ADJUSTING PLATE
122	P0563122	PHLP HD SCR 1/4-20 X 5/8
123	P0563123	HANDLE
124	P0563124	GEAR BOX COVER
125	P0563125	SET SCREW NPT 1/8
126	P0563126	HEX NUT M8-1.25
127	P0563127	CAP SCREW M8-1.25 X 75
128	P0563128	KEY 7 X 7 X 16
129	P0563129	WORM SHAFT
130	P0563130	OIL SEAL W/HOLE
131	P0563131	DRIVE SHAFT
132	P0563132	OIL SEAL W/O HOLE
133	P0563133	INT RETAINING RING 35MM
134	P0563134	BALL BEARING 6202Z
135	P0563135	ALUMINUM RING
136	P0563136	WORM GEAR
137	P0563137	GEAR BOX
138	P0563138	SET SCREW 5/16-18 X 1/2
139	P0563139	SPINDLE CONNECTOR
140	P0563140	HEX BOLT 5/16-18 X 1/2
141	P0563141	GEAR BOX FIXING PLATE
142	P0563142	HEX BOLT 3/8-16 X 1
143	P0563143	HEX NUT 5/8-18
144	P0563144	LOCK WASHER 5/8
145	P0563145	DUST PORT 4"
146	P0563146	DRIVE ROLLER
147V2	P0563147V2	MOTOR 2HP 220V 1-PH V2.10.11
147-1	P0563147-1	FAN COVER
147-2	P0563147-2	FAN
147-3	P0563147-3	S CAPACITOR 400M 125V 1-3/4 X 3-7/8
147-4	P0563147-4	CAPACITOR COVER
147-5	P0563147-5	ELECTRICAL BOX
147-6	P0563147-6	R CAPACITOR 60M 250V 1-3/8 X 3-3/8
148	P0563148	CAP SCREW 1/4-20 X 1-3/4

REF	PART #	DESCRIPTION
149	P0563149	MOTOR BRACKET
150	P0563150	LOCK NUT M12-1.75
151	P0563151	HEX BOLT M12-1.75 X 75
152	P0563152	HEX NUT 10-24
153	P0563153	SWITCH COVER
154	P0563154	PHLP HD SCR 10-24 X 3/4
155	P0563155	EMERGENCY STOP SWITCH
156	P0563156	STAR KNOB 5/16-18 X 1
157	P0563157	PLATE COVER W/DOOR
157-1	P0563157-1	DRIVER ROLLER COVER
158	P0563158	CAP SCREW 1/4-20 X 1/2
159	P0563159	THRUST BALL BEARING 5101
160	P0563160	PHLP HD SCR 1/4-20 X 1/4
161	P0563161	CAP SCREW 3/8-16 X 3/4
162	P0563162	CAST IRON TABLE U-TYPE
163	P0563163	CAP SCREW M4-.7 X 10
164	P0563164	KEY 8 X 8 X 315
165	P0563165	TABLE SPINDLE
166	P0563166	KNOB 3/8-16 X 1
167	P0563167	IDLER ROLLER
168	P0563168	BALL BEARING 6205Z
169	P0563169	HEX BOLT 5/16-18 X 1/2
170	P0563170	ADJUSTING PLATE WASHER 5/16
171	P0563171	IDLER ROLLER SPINDLE
172	P0563172	IDLER ROLLER BRACKET
173	P0563173	HEX BOLT 5/16-18 X 1
174	P0563174	SHAFT
175	P0563175	CAP SCREW 1/4-20 X 1-1/4
176	P0563176	HEX NUT 5/8-11
177	P0563177	FLAT WASHER 5/8
178	P0563178	CONDENSED SPRING
179	P0563179	LOCK NUT 1/4-20
180	P0563180	CAP SCREW 1/4-20 X 3/4
181	P0563181	SPINDLE
182	P0563182	SPINDLE BRACKET
183	P0563183	FEMALE KNOB 1/2-13
184	P0563184	HANDLE BAR
185	P0563185	HEX NUT 1/2-12
186	P0563186	CAP SCREW 5/16-18 X 1/2
187	P0563187	FLAT WASHER 5/16
188	P0563188	TENSIONING LINK ARM
189	P0563189	PLATEN
190	P0563190	LOCK WASHER 5/16
191	P0563191	HEX BOLT 5/16-18 X 1/2
192	P0563192	LOCK NUT 3/4-10
193	P0563193	HEX BOLT 3/4-10 X 2-1/4
194	P0563194	SWIVEL BRACKET
195	P0563195	HEX NUT 3/8-16
196	P0563196	HEX BOLT 3/8-16 X 3/4
197	P0563197	GEAR BOX
198	P0563198	BASE
199	P0563199	STRAIN RELIEF
199	P0563199	STRAIN RELIEF



# G0564 Breakdown

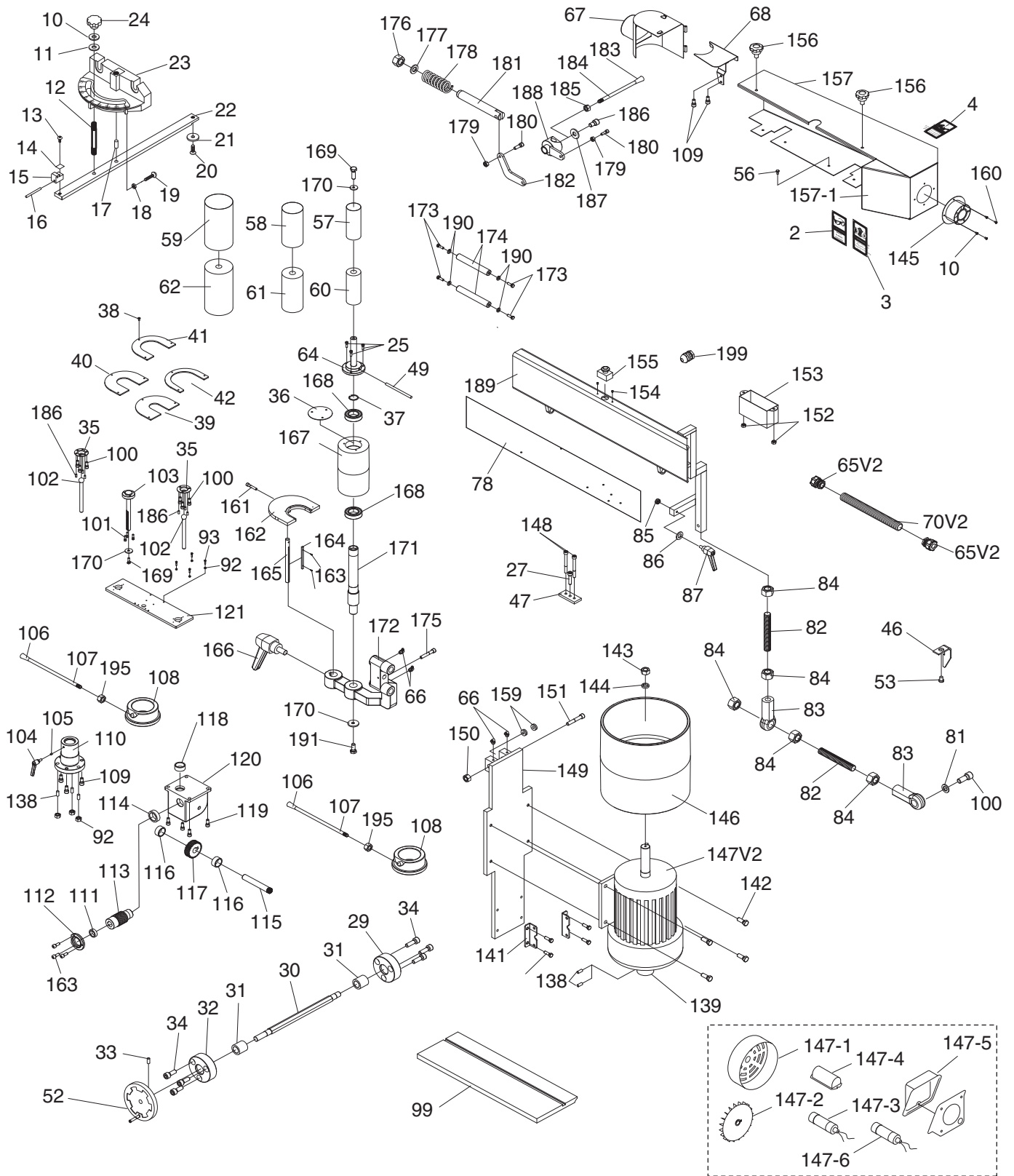

# G0564 Breakdown

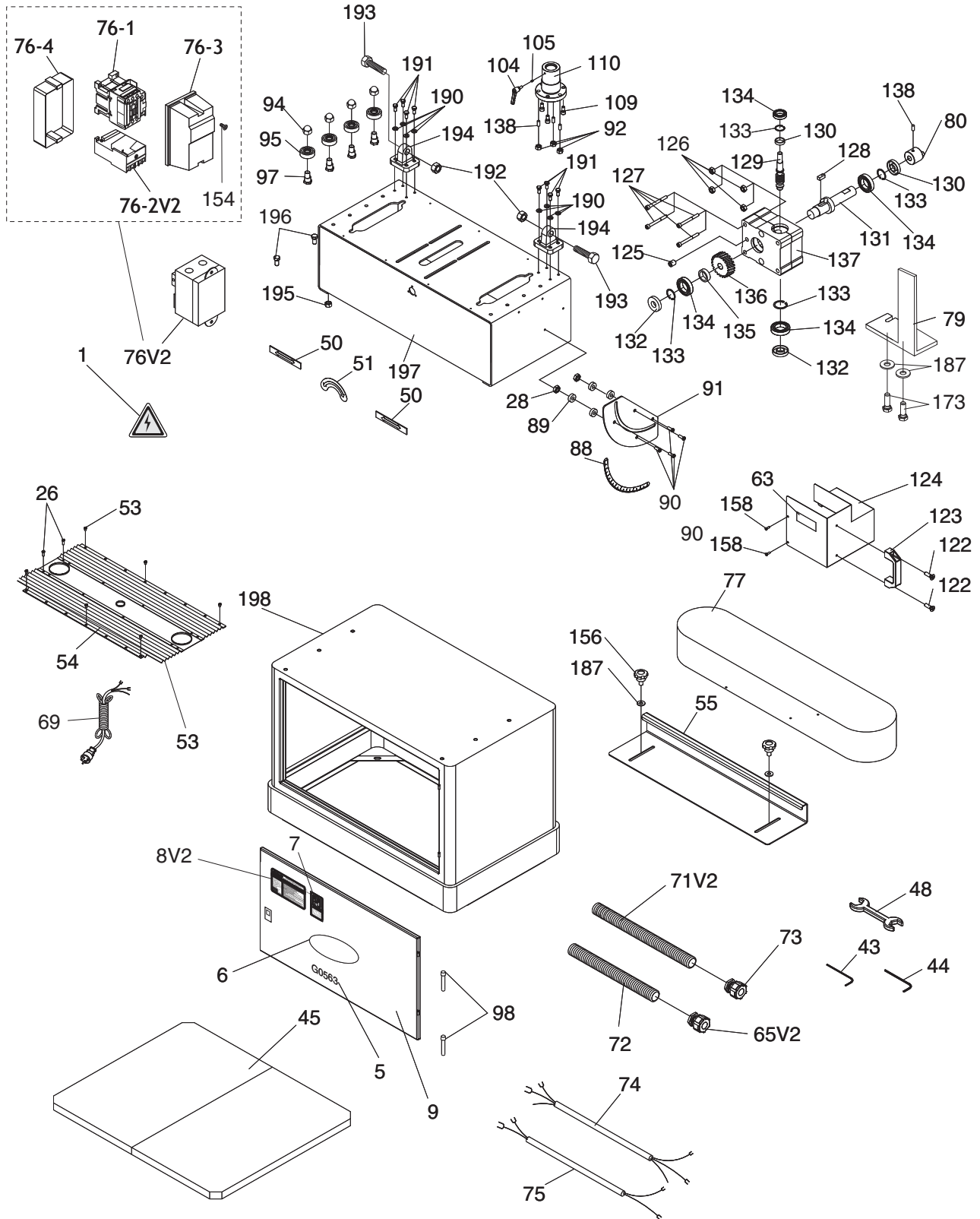

# G0564 Parts List

REF	PART #	DESCRIPTION
1	P0564001	ELECTRICITY 1.4W X 1.2H
2	P0564002	SAFETY GLASSES 2W X 3.3H V1
3	P0564003	RESPIRATOR 3.3W X 2H
4	P0564004	DISCONNECT LABEL
5	P0564005	MODEL NUMBER LABEL
6	P0564006	LOGO PLATE
7	P0564007	READ MANUAL LABEL
8V2	P0564008V2	MACHINE ID LABEL CSA V2.10.11
9	P0564009	DOOR W/LATCH
10	P0564010	FLAT WASHER 1/4
11	P0564011	WASHER 1/4 PLASTIC
12	P0564012	STUD 1/4-20 X 1-1/4
13	P0564013	PHLP HD SCR 10-24 X 1/4
14	P0564014	POINTER PLATE
15	P0564015	POINTER BODY
16	P0564016	STOP SHAFT
17	P0564017	PIVOT PIN
18	P0564018	HEX NUT 10-24
19	P0564019	PHLP HD SCR 10-24 X 3/4
20	P0564020	FLAT HD SCR 10-24 X 3/8
21	P0564021	T-SLOT WASHER
22	P0564022	MITER BAR
23	P0564023	MITER GAUGE BODY
24	P0564024	FEMALE KNOB 1/4-20
25	P0564025	CAP SCREW M5-.8 X 16
26	P0564026	PHLP HD SCR 10-24 X 3/4
27	P0564027	CAP SCREW 5/16-18 X 1-1/4
28	P0564028	HEX NUT 1/4-20
29	P0564029	HEX SPINDLE BACK COVER
30	P0564030	HEX SPINDLE
31	P0564031	SLEEVE
32	P0564032	HEX SPINDLE FRONT COVER
33	P0564033	SET SCREW 5/16-18 X 1/2
34	P0564034	CAP SCREW M6-1 X 16
35	P0564035	TABLE MOUNTING BRACKET
36	P0564036	IDLER ROLLER COVER
37	P0564037	EXT RETAINING RING 25MM
38	P0564038	FLAT HD SCR 10-24 X 3/8
39	P0564039	TABLE INSERT 1-1/2
40	P0564040	TABLE INSERT 2-1/2
41	P0564041	TABLE INSERT 3
42	P0564042	TABLE INSERT 4
43	P0564043	HEX WRENCH 5MM
44	P0564044	HEX WRENCH 6MM
45	P0564045	WOOD BOARD 25 X 395 X 457
46	P0564046	POINTER
47	P0564047	PLATE 70 X 31.7 X 5/16
48	P0564048	WRENCH 10 X 12MM OPEN-ENDS
49	P0564049	ROD
50	P0564050	TABLE ADJUSTMENT LABEL
51	P0564051	ROTATION LABEL
52	P0564052	HANDWHEEL
53	P0564053	PHLP HD SCR 10-24 X 3/8

REF	PART #	DESCRIPTION
54	P0564054	EXTENDABLE COVER
55	P0564055	FENCE
56	P0564056	HEX BOLT 1/4-20 X 1/4
57	P0564057	SANDING SLEEVE 1-1/2
58	P0564058	SANDING SLEEVE 2
59	P0564059	SANDING SLEEVE 3
60	P0564060	RUBBER DRUM 1-1/2
61	P0564061	RUBBER DRUM 2
62	P0564062	RUBBER DRUM 3
63	P0564063	ADJUSTMENT LABEL
64	P0564064	SANDING DRUM SPINDLE
65	P0564065	CONDUIT CONNECTOR 1/2 V1
65V2	P0564065V2	CONDUIT CONNECTOR 3/8" V2.09.11
66	P0564066	GREASE FITTING 1/8 30-DEG
67	P0564067	COVER FOR DUST PORT
68	P0564068	GUARD
69	P0564069	POWER CORD
70	P0564070	CONDUIT 1/2 PLASTIC V1
70V2	P0564070V2	PLASTIC CONDUIT 3/8 X 18" V2.09.11
71	P0564071	CONDUIT 1/2 PLASTIC V1
71V2	P0564071V2	PLASTIC CONDUIT 3/8 X 12" V2.09.11
72	P0564072	CONDUIT 3/8 PLASTIC
73	P0564073	CONDUIT CONNECTOR 3/8
74	P0564074	MOTOR POWER CORD
75	P0564075	EMERGENCY STOP PWR CORD
76	P0564076	SWITCH V1
76V2	P0564076V2	MAGNETIC SWITCH V2.10.11
76-1	P0564076-1	CONTACTOR SDE MA-09 220-240V
76-2V2	P0564076-2V2	OL RELAY SDE RA-20 12-18A V2.10.11
76-3	P0564076-3	MAG SWITCH FRONT COVER
76-4	P0564076-4	MAG SWITCH REAR COVER
77	P0564077	SANDING BELT 6 X 108
78	P0564078	GRAPHITE PAD 6-3/4 X 40-1/2"
79	P0564079	BACK STOP
80	P0564080	ECCENTRIC
81	P0564081	FLAT WASHER 1/4
82	P0564082	STUD-FT M14-2 X 95
83	P0564083	TIE ROD
84	P0564084	HEX NUT M14-2
85	P0564085	PLATEN NUT 3/8-16
86	P0564086	FLAT WASHER 3/8
87	P0564087	HANDLE 3/8-16 X 50
88	P0564088	ANGLE GAUGE LABEL
89	P0564089	MITER GAUGE SPACER
90	P0564090	FLAT HD SCR 1/4-20 X 3/4
91	P0564091	SCALE PLATE
92	P0564092	LOCK NUT 5/16-18
93	P0564093	CARRIAGE BOLT 5/16-18 X 1-1/4
94	P0564094	ACORN NUT 3/8-16
95	P0564095	BALL BEARING 6001ZZ
97	P0564097	ECCENTRIC BOLT
98	P0564098	HINGE PIN 8 X 45MM
99	P0564099	TABLE



# G0564 Parts List

REF	PART #	DESCRIPTION
100	P0564100	CAP SCREW 5/16-18 X 3/4
101	P0564101	HEX BOLT 5/16-18 X 1
102	P0564102	SPINDLE
103	P0564103	RACK GEAR
104	P0564104	HANDLE 1/4 X 1/2
105	P0564105	INSERT 5 X 3 COPPER
106	P0564106	FEMALE KNOB 3/8-16
107	P0564107	HANDLE BAR
108	P0564108	LOCK COLLAR
109	P0564109	CAP SCREW 1/4-20 X 1/2
110	P0564110	SPINDLE SPACER
111	P0564111	BALL BEARING 38 X 42 X 20T
112	P0564112	PACKING
113	P0564113	PINION ROD
114	P0564114	RING COPPER
115	P0564115	PINION SPINDLE
116	P0564116	SPACER
117	P0564117	PINION GEAR
118	P0564118	RING COPPER
119	P0564119	CAP SCREW 5/16-18 X 3/4
120	P0564120	RACK & PINION BOX
121	P0564121	ADJUSTING PLATE
122	P0564122	PHLP HD SCR 1/4-20 X 5/8
123	P0564123	HANDLE
124	P0564124	GEAR BOX COVER
125	P0564125	SET SCREW NPT 1/8
126	P0564126	HEX NUT M8-1.25
127	P0564127	CAP SCREW M8-1.25 X 75
128	P0564128	KEY 7 X 7 X 16
129	P0564129	WORM SHAFT
130	P0564130	OIL SEAL W/HOLE
131	P0564131	DRIVE SHAFT
132	P0564132	OIL SEAL W/O HOLE
133	P0564133	INT RETAINING RING 35MM
134	P0564134	BALL BEARING 6202Z
135	P0564135	ALUMINUM RING
136	P0564136	WORM GEAR
137	P0564137	GEAR BOX
138	P0564138	SET SCREW 5/16-18 X 1/2
139	P0564139	SPINDLE CONNECTOR
140	P0564140	HEX BOLT 5/16-18 X 1/2
141	P0564141	GEAR BOX FIXING PLATE
142	P0564142	HEX BOLT 3/8-16 X 1
143	P0564143	HEX NUT 5/8-18
144	P0564144	LOCK WASHER 5/8
145	P0564145	DUST PORT
146	P0564146	DRIVE ROLLER
147V2	P0564147V2	MOTOR 3HP 220V 1PH V2.10.11
147-1	P0564147-1	FAN COVER
147-2	P0564147-2	FAN
147-3	P0564147-3	S CAPACITOR 400M 125V 1-3/4 X 3-7/8
147-4	P0564147-4	CAPACITOR COVER
147-5	P0564147-5	ELECTRICAL BOX
147-6	P0564147-6	R CAPACITOR 60M 250V 1-3/8 x 3-3/8

REF	PART #	DESCRIPTION
148	P0564148	CAP SCREW 1/4-20 X 1-3/4
149	P0564149	MOTOR BRACKET
150	P0564150	LOCK NUT M12-1.75
151	P0564151	HEX BOLT M12-1.75 X 75
152	P0564152	HEX NUT 10-24
153	P0564153	SWITCH COVER
154	P0564154	PHLP HD SCR 10-24 X 3/4
155	P0564155	EMERGENCY STOP SWITCH
156	P0564156	STAR KNOB 5/16-18 X 3/4"
157	P0564157	PLATEN COVER
157-1	P0564157-1	DRIVER ROLLER COVER
158	P0564158	CAP SCREW 1/4-20 X 1/2
159	P0564159	THRUST BALL BEARING 5101
160	P0564160	PHLP HD SCR 1/4-20 X 1/4
161	P0564161	CAP SCREW 3/8-16 X 3/4
162	P0564162	CAST IRON TABLE U-TYPE
163	P0564163	CAP SCREW M4-.7 X 10
164	P0564164	KEY 8 X 8 X 315
165	P0564165	TABLE SPINDLE
166	P0564166	KNOB 3/8-16 X 1
167	P0564167	IDLER ROLLER
168	P0564168	BALL BEARING 6205Z
169	P0564169	HEX BOLT 5/16-18 X 1/2
170	P0564170	ADJUSTING PLATE WASHER 5/16
171	P0564171	IDLER ROLLER SPINDLE
172	P0564172	IDLER ROLLER BRACKET
173	P0564173	HEX BOLT 5/16-18 X 1
174	P0564174	SHAFT
175	P0564175	CAP SCREW 1/4-20 X 1-1/4
176	P0564176	HEX NUT 5/8-11
177	P0564177	FLAT WASHER 5/8
178	P0564178	CONDENSED SPRING
179	P0564179	LOCK NUT 1/4-20
180	P0564180	CAP SCREW 1/4-20 X 3/4
181	P0564181	SPINDLE
182	P0564182	SPINDLE BRACKET
183	P0564183	FEMALE KNOB 1/2-13
184	P0564184	HANDLE BAR
185	P0564185	HEX NUT 1/2-12
186	P0564186	CAP SCREW 5/16-18 X 1/2
187	P0564187	FLAT WASHER 5/16
188	P0564188	TENSIONING LINK ARM
189	P0564189	PLATEN
190	P0564190	LOCK WASHER 5/16
191	P0564191	HEX BOLT 5/16-18 X 1/2
192	P0564192	LOCK NUT 3/4-10
193	P0564193	HEX BOLT 3/4-10 X 2-1/4
194	P0564194	SWIVEL BRACKET
195	P0564195	HEX NUT 3/8-16
196	P0564196	HEX BOLT 3/8-16 X 3/4
197	P0564197	GEAR BOX
198	P0564198	BASE
199	P0564199	STRAIN RELIEF
199	P0564199	STRAIN RELIEF







# WARRANTY CARD

Name \_\_\_\_\_  
 Street \_\_\_\_\_  
 City \_\_\_\_\_ State \_\_\_\_\_ Zip \_\_\_\_\_  
 Phone # \_\_\_\_\_ Email \_\_\_\_\_  
 Model # \_\_\_\_\_ Order # \_\_\_\_\_ Serial # \_\_\_\_\_

The following information is given on a voluntary basis. It will be used for marketing purposes to help us develop better products and services. **Of course, all information is strictly confidential.**

1. How did you learn about us?

Advertisement       Friend       Catalog  
 Card Deck       Website       Other:

2. Which of the following magazines do you subscribe to?

<input type="checkbox"/> Cabinetmaker & FDM	<input type="checkbox"/> Popular Science	<input type="checkbox"/> Wooden Boat
<input type="checkbox"/> Family Handyman	<input type="checkbox"/> Popular Woodworking	<input type="checkbox"/> Woodshop News
<input type="checkbox"/> Hand Loader	<input type="checkbox"/> Precision Shooter	<input type="checkbox"/> Woodsmith
<input type="checkbox"/> Handy	<input type="checkbox"/> Projects in Metal	<input type="checkbox"/> Woodwork
<input type="checkbox"/> Home Shop Machinist	<input type="checkbox"/> RC Modeler	<input type="checkbox"/> Woodworker West
<input type="checkbox"/> Journal of Light Cont.	<input type="checkbox"/> Rifle	<input type="checkbox"/> Woodworker's Journal
<input type="checkbox"/> Live Steam	<input type="checkbox"/> Shop Notes	<input type="checkbox"/> Other:
<input type="checkbox"/> Model Airplane News	<input type="checkbox"/> Shotgun News	
<input type="checkbox"/> Old House Journal	<input type="checkbox"/> Today's Homeowner	
<input type="checkbox"/> Popular Mechanics	<input type="checkbox"/> Wood	

3. What is your annual household income?

\$20,000-\$29,000       \$30,000-\$39,000       \$40,000-\$49,000  
 \$50,000-\$59,000       \$60,000-\$69,000       \$70,000+

4. What is your age group?

20-29       30-39       40-49  
 50-59       60-69       70+

5. How long have you been a woodworker/metalworker?

0-2 Years       2-8 Years       8-20 Years       20+ Years

6. How many of your machines or tools are Grizzly?

0-2       3-5       6-9       10+

7. Do you think your machine represents a good value?

Yes       No

8. Would you recommend Grizzly Industrial to a friend?

Yes       No

9. Would you allow us to use your name as a reference for Grizzly customers in your area?

**Note:** We never use names more than 3 times.       Yes       No

10. Comments: \_\_\_\_\_

\_\_\_\_\_  
 \_\_\_\_\_  
 \_\_\_\_\_

CUT ALONG DOTTED LINE

FOLD ALONG DOTTED LINE

\_\_\_\_\_  
\_\_\_\_\_  
\_\_\_\_\_



Place  
Stamp  
Here



**GRIZZLY INDUSTRIAL, INC.**  
**P.O. BOX 2069**  
**BELLINGHAM, WA 98227-2069**



FOLD ALONG DOTTED LINE

Send a Grizzly Catalog to a friend:

Name \_\_\_\_\_  
Street \_\_\_\_\_  
City \_\_\_\_\_ State \_\_\_\_\_ Zip \_\_\_\_\_

TAPE ALONG EDGES--PLEASE DO NOT STAPLE

# WARRANTY & RETURNS

---

Grizzly Industrial, Inc. warrants every product it sells for a period of **1 year** to the original purchaser from the date of purchase. This warranty does not apply to defects due directly or indirectly to misuse, abuse, negligence, accidents, repairs or alterations or lack of maintenance. This is Grizzly's sole written warranty and any and all warranties that may be implied by law, including any merchantability or fitness, for any particular purpose, are hereby limited to the duration of this written warranty. We do not warrant or represent that the merchandise complies with the provisions of any law or acts unless the manufacturer so warrants. In no event shall Grizzly's liability under this warranty exceed the purchase price paid for the product and any legal actions brought against Grizzly shall be tried in the State of Washington, County of Whatcom.

We shall in no event be liable for death, injuries to persons or property or for incidental, contingent, special, or consequential damages arising from the use of our products.

To take advantage of this warranty, contact us by mail or phone and give us all the details. We will then issue you a "Return Number," which must be clearly posted on the outside as well as the inside of the carton. We will not accept any item back without this number. Proof of purchase must accompany the merchandise.

The manufacturers reserve the right to change specifications at any time because they constantly strive to achieve better quality equipment. We make every effort to ensure that our products meet high quality and durability standards and we hope you never need to use this warranty.

Please feel free to write or call us if you have any questions about the machine or the manual.

Thank you again for your business and continued support. We hope to serve you again soon.



# *grizzly.com*<sup>®</sup>

**TOOL WEBSITE**

Buy Direct and Save with Grizzly<sup>®</sup> – Trusted, Proven and a Great Value!  
~Since 1983~

*Visit Our Website Today For  
Current Specials!*

**ORDER  
24 HOURS A DAY!  
1-800-523-4777**

