

Grizzly ***Industrial, Inc.***®

MODEL G0529 **OSCILLATING SPINDLE &** **12" DISC SANDER** **OWNER'S MANUAL** *(For models manufactured since 04/17)*



COPYRIGHT © SEPTEMBER, 2003 BY GRIZZLY INDUSTRIAL, INC. REVISED MARCH, 2018 (HE)
**WARNING: NO PORTION OF THIS MANUAL MAY BE REPRODUCED IN ANY SHAPE
OR FORM WITHOUT THE WRITTEN APPROVAL OF GRIZZLY INDUSTRIAL, INC.**

#JT5422 PRINTED IN TAIWAN

V2.03.18



WARNING!

This manual provides critical safety instructions on the proper setup, operation, maintenance, and service of this machine/tool. Save this document, refer to it often, and use it to instruct other operators.

Failure to read, understand and follow the instructions in this manual may result in fire or serious personal injury—including amputation, electrocution, or death.

The owner of this machine/tool is solely responsible for its safe use. This responsibility includes but is not limited to proper installation in a safe environment, personnel training and usage authorization, proper inspection and maintenance, manual availability and comprehension, application of safety devices, cutting/sanding/grinding tool integrity, and the usage of personal protective equipment.

The manufacturer will not be held liable for injury or property damage from negligence, improper training, machine modifications or misuse.



WARNING!

Some dust created by power sanding, sawing, grinding, drilling, and other construction activities contains chemicals known to the State of California to cause cancer, birth defects or other reproductive harm. Some examples of these chemicals are:

- **Lead from lead-based paints.**
- **Crystalline silica from bricks, cement and other masonry products.**
- **Arsenic and chromium from chemically-treated lumber.**

Your risk from these exposures varies, depending on how often you do this type of work. To reduce your exposure to these chemicals: Work in a well ventilated area, and work with approved safety equipment, such as those dust masks that are specially designed to filter out microscopic particles.

Table of Contents

INTRODUCTION	2	SECTION 4: OPERATIONS	20
Contact Info.....	2	Operation Overview	20
Manual Accuracy	2	Power Switch	20
Identification.....	3	Spindle Sanding.....	21
Machine Data Sheet	4	Disc Sanding.....	22
SECTION 1: SAFETY	6	Miter Sanding.....	22
Safety Instructions for Machinery	6	SECTION 5: ACCESSORIES	23
Additional Safety for Combo Sanders	8	SECTION 6: MAINTENANCE	24
SECTION 2: POWER SUPPLY	9	Schedule	24
SECTION 3: SET UP	11	Cleaning & Protecting	24
Unpacking	11	SECTION 7: SERVICE	25
Inventory	11	Troubleshooting	25
Hardware Recognition Chart	12	SECTION 8: WIRING	27
Cleanup.....	13	Wiring Safety Instructions	27
Site Considerations.....	13	Wiring Diagram	28
Beginning Assembly	14	SECTION 9: PARTS	29
Cabinet Assembly.....	14	Frame Breakdown.....	29
Mounting Sander.....	15	Main Parts List.....	30
Installing Spindle.....	15	Cabinet Breakdown.....	32
Table Inserts	16	WARRANTY & RETURNS	35
Squaring Table.....	16		
Squaring Disc Sander	17		
Sanding Disc.....	18		
Installation.....	18		
Aligning Table	18		
Miter Gauge	19		
Dust Collection.....	19		

INTRODUCTION

Contact Info

We stand behind our machines! If you have questions or need help, contact us with the information below. Before contacting, make sure you get the **serial number** and **manufacture date** from the machine ID label. This will help us help you faster.

Grizzly Technical Support
1815 W. Battlefield
Springfield, MO 65807
Phone: (570) 546-9663
Email: techsupport@grizzly.com

We want your feedback on this manual. What did you like about it? Where could it be improved? Please take a few minutes to give us feedback.

Grizzly Documentation Manager
P.O. Box 2069
Bellingham, WA 98227-2069
Email: manuals@grizzly.com

Manual Accuracy

We are proud to provide a high-quality owner's manual with your new machine!

We made every effort to be exact with the instructions, specifications, drawings, and photographs in this manual. Sometimes we make mistakes, but our policy of continuous improvement also means that **sometimes the machine you receive is slightly different than shown in the manual.**

If you find this to be the case, and the difference between the manual and machine leaves you confused or unsure about something, check our website for an updated version. We post current manuals and manual updates for free on our website at www.grizzly.com.

Alternatively, you can call our Technical Support for help. Before calling, make sure you write down the **Manufacture Date** and **Serial Number** from the machine ID label (see below). This information is required for us to provide proper tech support, and it helps us determine if updated documentation is available for your machine.

		MODEL GXXXX MACHINE NAME	
SPECIFICATIONS		▲ WARNING!	
Motor:		To reduce risk of serious injury when using this machine:	
Specification:		1. Read manual before operation.	
Specification:		2. Wear safety glasses and respirator.	
Specification:		3. Make sure motor is correctly adjusted/setup and	
Specification:		4. power is connected to grounded circuit before starting.	
Weight:		5. Make sure the motor has stopped and disconnect	
		6. power before adjustments, maintenance, or service.	
		7. DO NOT expose to rain or dampness.	
		8. DO NOT modify this machine in any way.	
		9. Do not use while intoxicated or under the influence of drugs or alcohol.	
		10. Maintain machine carefully to prevent accidents.	
		Manufactured for Grizzly in Taiwan	

Manufacture Date []

Serial Number []

Identification

An important part of safety is knowing your machine and its components. Take the time to familiarize yourself with the features of your new G0529 Oscillating Spindle & 12" Disc Sander. They will be frequently mentioned throughout the instructions in this manual.

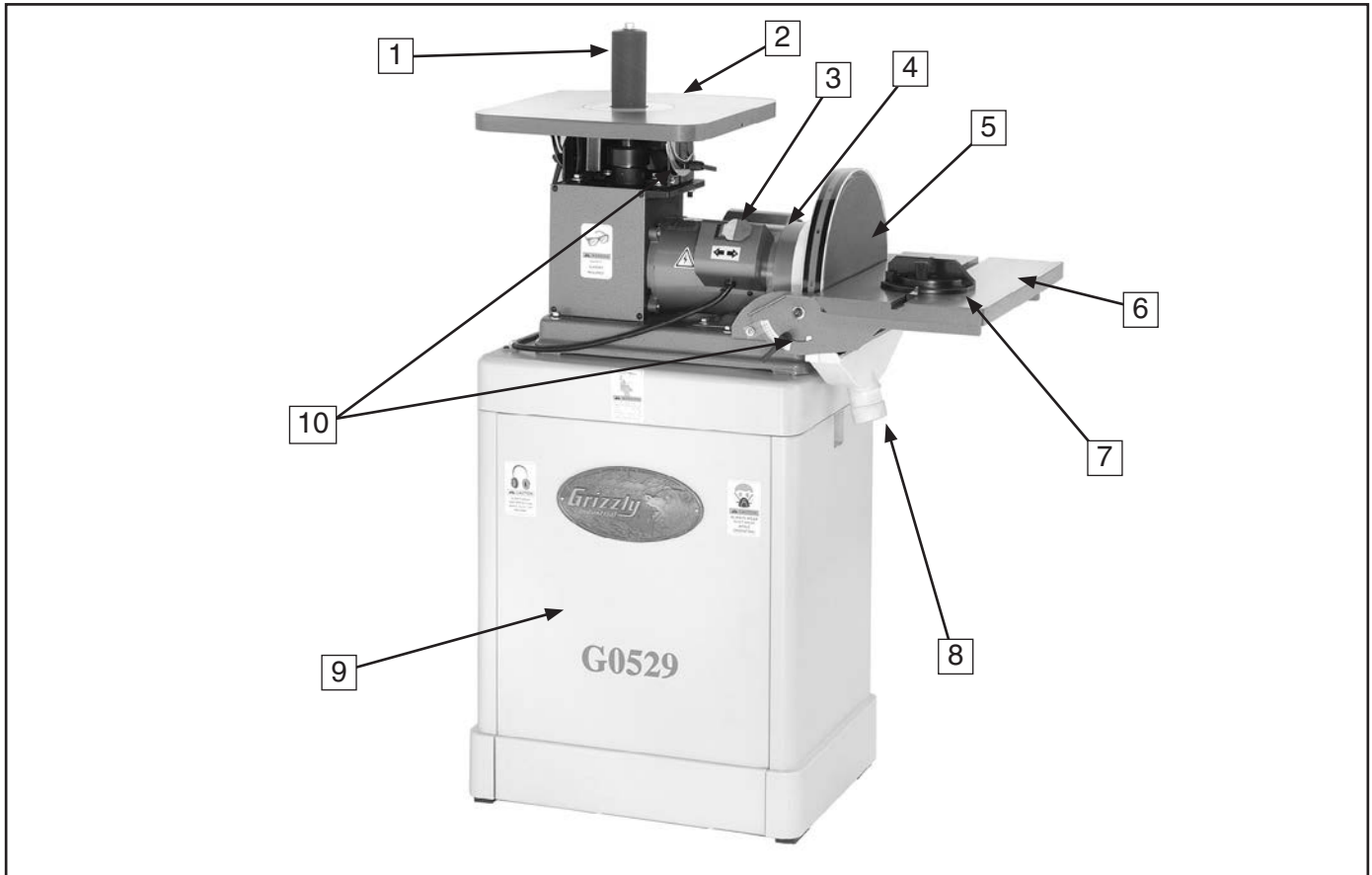

Figure 1. Machine features.

- | | |
|------------------------------------|---------------------------------------|
| 1. 5½" Sanding Spindle | 6. Cast-Iron Disc Sanding Table |
| 2. Cast-Iron Spindle Sanding Table | 7. Miter Gauge |
| 3. ON/OFF Switch | 8. Dust Port (Spindle Port Not Shown) |
| 4. Motor | 9. Cabinet |
| 5. 12" Sanding Disc | 10. Graduated Scales |





MACHINE DATA SHEET

Customer Service #: (570) 546-9663 · To Order Call: (800) 523-4777 · Fax #: (800) 438-5901

MODEL G0529 OSCILLATING SPINDLE / 12" DISC SANDER

Product Dimensions:

Weight..... 166 lbs.
 Width (side-to-side) x Depth (front-to-back) x Height..... 32 x 18 x 47 in.
 Footprint (Length x Width)..... 21-1/4 x 16-1/2 in.

Shipping Dimensions:

Type..... Cardboard Box
 Content..... Machine
 Weight..... 181 lbs.
 Length x Width x Height..... 34 x 20 x 21 in.
 Must Ship Upright..... Yes

Electrical:

Power Requirement..... 110V, Single-Phase, 60 Hz
 Prewired Voltage..... 110V
 Full-Load Current Rating..... 10A
 Minimum Circuit Size..... 15A
 Connection Type..... Cord & Plug
 Power Cord Included..... Yes
 Power Cord Length..... 6 ft.
 Power Cord Gauge..... 14 AWG
 Plug Included..... Yes
 Included Plug Type..... 5-15
 Switch Type..... Paddle Safety Switch w/Removable Key

Motors:

Main

Horsepower..... 1 HP
 Phase..... Single-Phase
 Amps..... 10A
 Speed..... 1725 RPM
 Type..... TEFC Capacitor-Start Induction
 Power Transfer Gear Drive
 Bearings..... Sealed & Permanently Lubricated

Main Specifications:

Disc Sander Info

Disc Diameter..... 12 in.
 Disc Speed..... 1725 RPM
 Disc Sandpaper Backing Type..... PSA
 Table Length..... 17-3/4 in.
 Table Width..... 10 in.
 Table Thickness..... 1 in.
 Table Tilt..... Left 0, Right 45 deg.
 Table-to-Floor Height..... 33 in.

Spindle Sander Info

Sanding Drum Diameters.....	1/4, 5/8, 1-1/2, 2 in.
Sanding Drum Length.....	5-1/2 in.
Spindle Speed.....	1725 RPM
Spindle Oscillation.....	60 SPM
Stroke Length.....	1 in.
Table Length.....	14-1/2 in.
Table Width.....	14-1/2 in.
Table Thickness.....	1 in.
Table-to-Floor Height.....	42 in.
Spindle Shaft Diameter.....	1/4 in.
Number of Table Inserts.....	4
Included Sanding Sleeve Grit Size.....	100
Table Tilt.....	Left 10, Right 45 deg.

Construction Materials

Base.....	Preformed Steel
Stand.....	Preformed Steel
Table.....	Precision Ground Cast Iron
Frame.....	Cast Iron
Disc.....	Computer Balanced Aluminum
Miter Gauge.....	Plastic/Steel Bar
Paint Type/Finish.....	Powder Coated

Other Related Info

Miter Gauge Slot Width.....	3/4 in.
Miter Gauge Slot Height.....	3/8 in.
Number of Dust Ports.....	2
Dust Port Size.....	2 in.
Compatible Mobile Base.....	D2057A

Other Specifications:

Country of Origin	Taiwan
Warranty	1 Year
Approximate Assembly & Setup Time	45 Minutes
Serial Number Location	ID Label on Front of Stand
ISO 9001 Factory	Yes
Certified by a Nationally Recognized Testing Laboratory (NRTL)	No

Features:

- Four Spindle Sizes
- Miter Gauge Included
- Includes Formed and Welded Steel Stand
- Both Tables Tilt
- Two Cast-Iron Tables
- Safety Paddle Switch with Lock

SECTION 1: SAFETY

For Your Own Safety, Read Instruction Manual Before Operating This Machine

The purpose of safety symbols is to attract your attention to possible hazardous conditions. This manual uses a series of symbols and signal words intended to convey the level of importance of the safety messages. The progression of symbols is described below. Remember that safety messages by themselves do not eliminate danger and are not a substitute for proper accident prevention measures. Always use common sense and good judgment.

⚠ DANGER Indicates an imminently hazardous situation which, if not avoided, **WILL** result in death or serious injury.

⚠ WARNING Indicates a potentially hazardous situation which, if not avoided, **COULD** result in death or serious injury.

⚠ CAUTION Indicates a potentially hazardous situation which, if not avoided, **MAY** result in minor or moderate injury. It may also be used to alert against unsafe practices.

NOTICE This symbol is used to alert the user to useful information about proper operation of the machine.

Safety Instructions for Machinery

⚠ WARNING

OWNER'S MANUAL. Read and understand this owner's manual **BEFORE** using machine.

TRAINED OPERATORS ONLY. Untrained operators have a higher risk of being hurt or killed. Only allow trained/supervised people to use this machine. When machine is not being used, disconnect power, remove switch keys, or lock-out machine to prevent unauthorized use—especially around children. Make your workshop kid proof!

DANGEROUS ENVIRONMENTS. Do not use machinery in areas that are wet, cluttered, or have poor lighting. Operating machinery in these areas greatly increases the risk of accidents and injury.

MENTAL ALERTNESS REQUIRED. Full mental alertness is required for safe operation of machinery. Never operate under the influence of drugs or alcohol, when tired, or when distracted.

ELECTRICAL EQUIPMENT INJURY RISKS. You can be shocked, burned, or killed by touching live electrical components or improperly grounded machinery. To reduce this risk, only allow qualified service personnel to do electrical installation or repair work, and always disconnect power before accessing or exposing electrical equipment.

DISCONNECT POWER FIRST. Always disconnect machine from power supply **BEFORE** making adjustments, changing tooling, or servicing machine. This prevents an injury risk from unintended startup or contact with live electrical components.

EYE PROTECTION. Always wear ANSI-approved safety glasses or a face shield when operating or observing machinery to reduce the risk of eye injury or blindness from flying particles. Everyday eyeglasses are **NOT** approved safety glasses.

WARNING

WEARING PROPER APPAREL. Do not wear clothing, apparel or jewelry that can become entangled in moving parts. Always tie back or cover long hair. Wear non-slip footwear to reduce risk of slipping and losing control or accidentally contacting cutting tool or moving parts.

HAZARDOUS DUST. Dust created by machinery operations may cause cancer, birth defects, or long-term respiratory damage. Be aware of dust hazards associated with each workpiece material. Always wear a NIOSH-approved respirator to reduce your risk.

HEARING PROTECTION. Always wear hearing protection when operating or observing loud machinery. Extended exposure to this noise without hearing protection can cause permanent hearing loss.

REMOVE ADJUSTING TOOLS. Tools left on machinery can become dangerous projectiles upon startup. Never leave chuck keys, wrenches, or any other tools on machine. Always verify removal before starting!

USE CORRECT TOOL FOR THE JOB. Only use this tool for its intended purpose—do not force it or an attachment to do a job for which it was not designed. Never make unapproved modifications—modifying tool or using it differently than intended may result in malfunction or mechanical failure that can lead to personal injury or death!

AWKWARD POSITIONS. Keep proper footing and balance at all times when operating machine. Do not overreach! Avoid awkward hand positions that make workpiece control difficult or increase the risk of accidental injury.

CHILDREN & BYSTANDERS. Keep children and bystanders at a safe distance from the work area. Stop using machine if they become a distraction.

GUARDS & COVERS. Guards and covers reduce accidental contact with moving parts or flying debris. Make sure they are properly installed, undamaged, and working correctly **BEFORE** operating machine.

FORCING MACHINERY. Do not force machine. It will do the job safer and better at the rate for which it was designed.

NEVER STAND ON MACHINE. Serious injury may occur if machine is tipped or if the cutting tool is unintentionally contacted.

STABLE MACHINE. Unexpected movement during operation greatly increases risk of injury or loss of control. Before starting, verify machine is stable and mobile base (if used) is locked.

USE RECOMMENDED ACCESSORIES. Consult this owner's manual or the manufacturer for recommended accessories. Using improper accessories will increase the risk of serious injury.

UNATTENDED OPERATION. To reduce the risk of accidental injury, turn machine **OFF** and ensure all moving parts completely stop before walking away. Never leave machine running while unattended.

MAINTAIN WITH CARE. Follow all maintenance instructions and lubrication schedules to keep machine in good working condition. A machine that is improperly maintained could malfunction, leading to serious personal injury or death.

DAMAGED PARTS. Regularly inspect machine for damaged, loose, or mis-adjusted parts—or any condition that could affect safe operation. Immediately repair/replace **BEFORE** operating machine. For your own safety, **DO NOT** operate machine with damaged parts!

MAINTAIN POWER CORDS. When disconnecting cord-connected machines from power, grab and pull the plug—**NOT** the cord. Pulling the cord may damage the wires inside. Do not handle cord/plug with wet hands. Avoid cord damage by keeping it away from heated surfaces, high traffic areas, harsh chemicals, and wet/damp locations.

EXPERIENCING DIFFICULTIES. If at any time you experience difficulties performing the intended operation, stop using the machine! Contact our Technical Support at (570) 546-9663.

Additional Safety for Combo Sanders

WARNING

Serious injury or death can occur from fingers, clothing, jewelry, or hair getting entangled in rotating disc, belt, spindle or other moving components. Abrasion injuries can occur from touching moving sandpaper with bare skin. Workpieces thrown by sanding surface can strike operator or bystanders with moderate force, causing impact injuries. Long-term respiratory damage can occur from using sander without proper use of a respirator. To reduce the risk of these hazards, operator or bystanders **MUST** completely heed the hazards and warnings below.

SANDPAPER DIRECTION. Feeding workpiece incorrectly can cause it to be thrown from machine, striking operator or bystanders, or causing your hands to slip into the moving sandpaper. To reduce these risks, only sand against direction of sandpaper travel, ensure workpiece is properly supported, and avoid introducing sharp edges into moving sandpaper on the leading side of the workpiece.

HAND PLACEMENT. Rotating sandpaper can remove a large amount of flesh quickly. Always keep hands away from sandpaper during operation. Never touch moving sandpaper on purpose. Use a brush to clean table of sawdust and chips.

FEEDING WORKPIECE. Forcefully jamming workpiece into sanding surface could cause it to be grabbed aggressively, pulling hands into sanding surface. Firmly grasp workpiece in both hands and ease it into sandpaper using light pressure.

AVOIDING ENTANGLEMENT. Becoming entangled in moving parts can cause pinching and crushing injuries. To avoid these hazards, keep all guards in place and closed. **DO NOT** wear loose clothing, gloves, or jewelry, and tie back long hair.

WORKPIECE SUPPORT. Workpiece kickback can occur with violent force if workpiece is not properly supported during operation. Always sand with workpiece firmly against table or another support device.

SANDING DUST. Sanding creates large amounts of dust that can lead to eye injury or respiratory illness. Reduce your risk by always wearing approved eye and respiratory protection when using sander. Never operate without adequate dust collection system in place and running. However, dust collection is not a substitute for using a respirator.

WORKPIECE INSPECTION. Nails, staples, knots, or other imperfections in workpiece can be dislodged and thrown from sander at a high rate of speed at people, or cause damage to sandpaper or sander. Never sand stock that has embedded foreign objects or questionable imperfections.

SANDPAPER CONDITION. Worn or damaged sandpaper can fly apart and throw debris at operator, or aggressively grab workpiece, resulting in subsequent injuries from operator loss of workpiece control. Always inspect sandpaper before operation and replace if worn or damaged.

IN-RUNNING NIP POINTS. The gap between moving sandpaper and fixed table/support creates a pinch point for fingers or workpieces; the larger this gap is, the greater the risk of fingers or workpieces getting caught in it. Minimize this risk by adjusting table/support to no more than $\frac{1}{16}$ " away from sandpaper. For spindle sanders, always use the table insert that fits closest diameter of installed drum.

MINIMUM STOCK DIMENSION. Small workpieces can be aggressively pulled from your hands, causing contact with sanding surface. Always use a jig or other holding device when sanding small workpieces, and keep hands and fingers at least 2" away from sanding surface.

WORKPIECE INTEGRITY. Sanding fragile workpieces can result in loss of control, resulting in abrasion injuries, impact injuries, or damage to sandpaper. Only sand solid workpieces that can withstand power sanding forces. Make sure workpiece shape is properly supported; avoid sanding workpieces without flat bottom surfaces unless some type of jig is used to maintain support and control when sanding force is applied.

SECTION 2: POWER SUPPLY

Availability

Before installing the machine, consider the availability and proximity of the required power supply circuit. If an existing circuit does not meet the requirements for this machine, a new circuit must be installed. To minimize the risk of electrocution, fire, or equipment damage, installation work and electrical wiring must be done by an electrician or qualified service personnel in accordance with all applicable codes and standards.

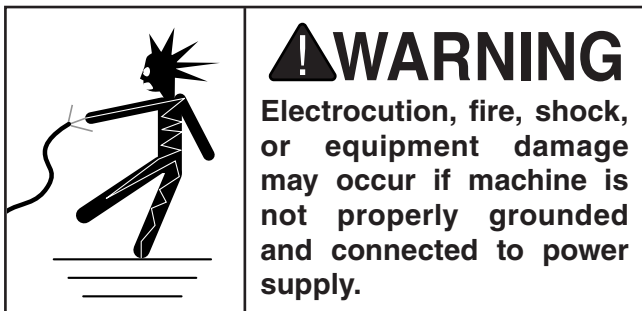

Full-Load Current Rating

The full-load current rating is the amperage a machine draws at 100% of the rated output power. On machines with multiple motors, this is the amperage drawn by the largest motor or sum of all motors and electrical devices that might operate at one time during normal operations.

Full-Load Current Rating at 110V..... 10 Amps

The full-load current is not the maximum amount of amps that the machine will draw. If the machine is overloaded, it will draw additional amps beyond the full-load rating.

If the machine is overloaded for a sufficient length of time, damage, overheating, or fire may result—especially if connected to an undersized circuit. To reduce the risk of these hazards, avoid overloading the machine during operation and make sure it is connected to a power supply circuit that meets the specified circuit requirements.

! WARNING

Serious injury could occur if you connect machine to power before completing setup process. DO NOT connect to power until instructed later in this manual.

110V Circuit Requirements

This machine is prewired to operate on a power supply circuit that has a verified ground and meets the following requirements:

Nominal Voltage 110V, 115V, 120V
Cycle.....60 Hz
Phase..... Single-Phase
Power Supply Circuit 15 Amps

A power supply circuit includes all electrical equipment between the breaker box or fuse panel in the building and the machine. The power supply circuit used for this machine must be sized to safely handle the full-load current drawn from the machine for an extended period of time. (If this machine is connected to a circuit protected by fuses, use a time delay fuse marked D.)

! CAUTION

For your own safety and protection of property, consult an electrician if you are unsure about wiring practices or electrical codes in your area.

Note: *Circuit requirements in this manual apply to a dedicated circuit—where only one machine will be running on the circuit at a time. If machine will be connected to a shared circuit where multiple machines may be running at the same time, consult an electrician or qualified service personnel to ensure circuit is properly sized for safe operation.*

Grounding & Plug Requirements

This machine **MUST** be grounded. In the event of certain malfunctions or breakdowns, grounding reduces the risk of electric shock by providing a path of least resistance for electric current.

This machine is equipped with a power cord that has an equipment-grounding wire and a grounding plug. Only insert plug into a matching receptacle (outlet) that is properly installed and grounded in accordance with all local codes and ordinances. **DO NOT** modify the provided plug!

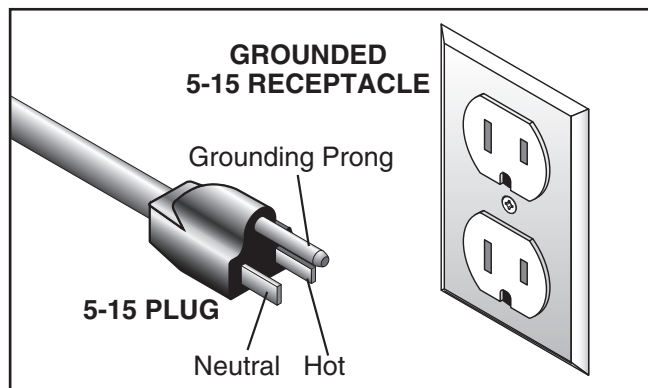

Figure 2. Typical 5-15 plug and receptacle.

⚠ CAUTION

SHOCK HAZARD!

Two-prong outlets do not meet the grounding requirements for this machine. Do not modify or use an adapter on the plug provided—if it will not fit the outlet, have a qualified electrician install the proper outlet with a verified ground.

Improper connection of the equipment-grounding wire can result in a risk of electric shock. The wire with green insulation (with or without yellow stripes) is the equipment-grounding wire. If repair or replacement of the power cord or plug is necessary, do not connect the equipment-grounding wire to a live (current carrying) terminal.

Check with a qualified electrician or service personnel if you do not understand these grounding requirements, or if you are in doubt about whether the tool is properly grounded. If you ever notice that a cord or plug is damaged or worn, disconnect it from power, and immediately replace it with a new one.

Extension Cords

We do not recommend using an extension cord with this machine. If you must use an extension cord, only use it if absolutely necessary and only on a temporary basis.

Extension cords cause voltage drop, which can damage electrical components and shorten motor life. Voltage drop increases as the extension cord size gets longer and the gauge size gets smaller (higher gauge numbers indicate smaller sizes).

Any extension cord used with this machine must be in good condition and contain a ground wire and matching plug/receptacle. Additionally, it must meet the following size requirements:

Minimum Gauge Size 14 AWG
Maximum Length (Shorter is Better).....50 ft.

SECTION 3: SET UP

Unpacking

The Model G0529 Oscillating Spindle & 12" Disc Sander was carefully packed at the factory. If you discover the machine is damaged after you have signed for delivery, and the truck and driver are gone, you will need to file a freight claim with the carrier. Save the containers and all packing materials for possible inspection by the carrier or its agent. Without the packing materials, filing a freight claim can be difficult. If you need assistance determining whether you need to file a freight claim, or with the procedure to file one, please contact our Customer Service.

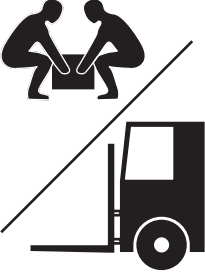

⚠ WARNING
HEAVY LIFT!
 Straining or crushing injury may occur from improperly lifting machine or some of its parts. To reduce this risk, get help from other people and use a forklift (or other lifting equipment) rated for weight of this machine.

NOTICE

If you cannot find an item on this list, carefully check around/inside the machine and packaging materials. Often, these items get lost in packaging materials while unpacking or they are pre-installed at the factory.



⚠ WARNING
SUFFOCATION HAZARD!
 Keep children and pets away from plastic bags or packing materials shipped with this machine. Discard immediately.

Inventory

Box 1 (Figure 3)	Qty
A. Sander Unit.....	1
B. Left and Right Side Panels.....	2
C. Front and Rear Panels.....	2
D. Miter Gauge Assembly	1
E. Spindle Assemblies	
-2"	1
-1½"	1
-5/8"	1
-¼"	1
F. Table Inserts	
-Elliptical Table Insert 2".....	1
-Table Insert 2"	1
-Elliptical Table Insert ¾".....	1
-Table Insert ¾"	1
G. Rubber Floor Pads	
-Flat Head Screws 5/16"-18 x ¾"	4
-Washers 5/16".....	4
-Nuts 5/16"	4
H. Wrench Hardware Bag	
-Open-End Wrench 17mm.....	2
-Open-End Wrench 12mm.....	1
I. Hardware Bag	
-Hex Bolts 5/16"-18 x ¾"	10
-Hex Nuts 5/16"-18	8
-Lock Washers 5/16".....	10
-Flat Washers 5/16"	18
-Hex Wrenches 4, 5, 6mm.....	1 Ea.

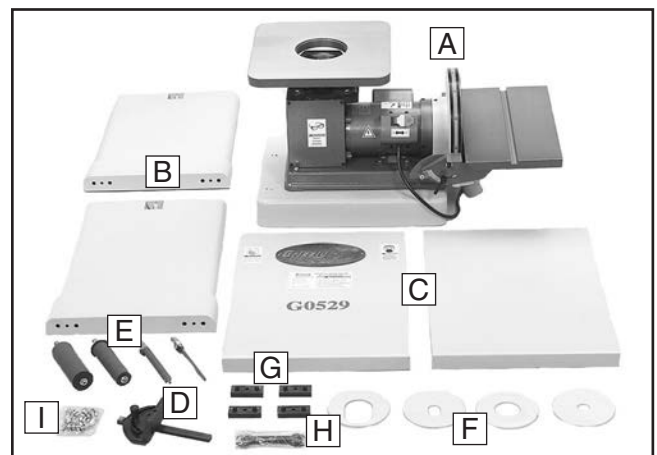

Figure 3. G0529 inventory.

Hardware Recognition Chart

USE THIS CHART TO MATCH UP HARDWARE DURING THE ASSEMBLY PROCESS.

MEASURE BOLT DIAMETER BY PLACING INSIDE CIRCLE

- #10
- 1/4"
- 5/16"
- 3/8"
- 7/16"
- 1/2"

- 4mm
- 5mm
- 6mm
- 8mm
- 10mm
- 12mm
- 16mm

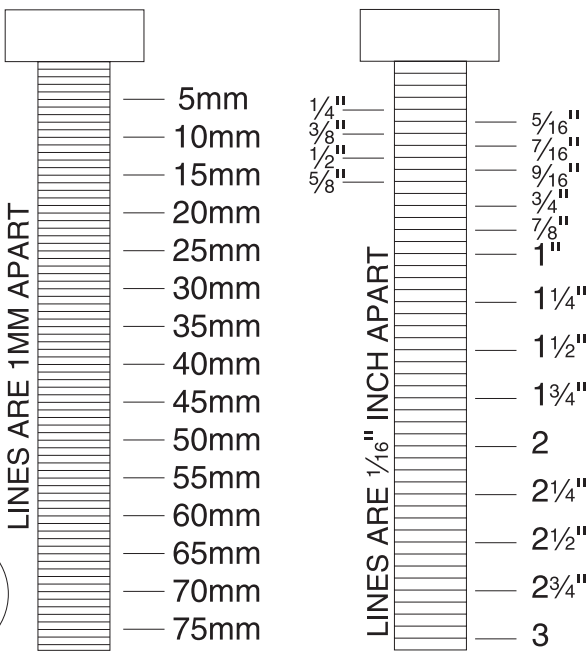
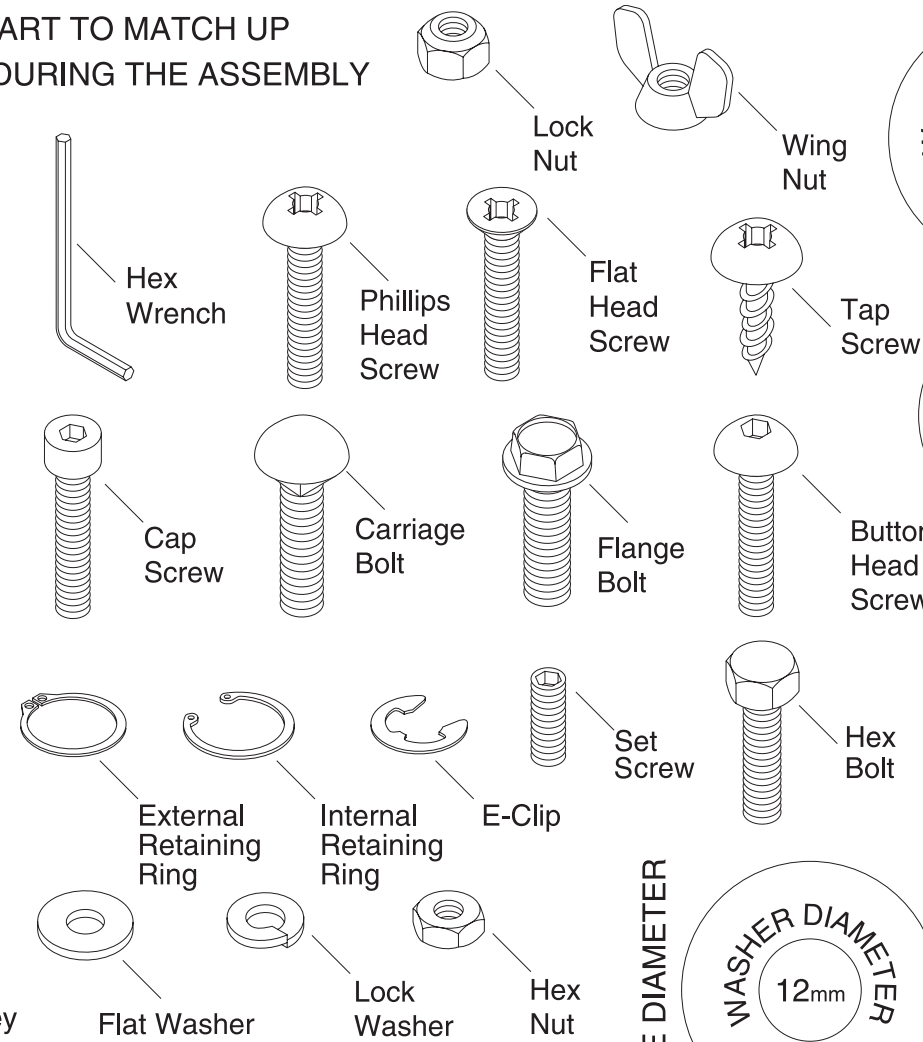

WASHERS ARE MEASURED BY THE INSIDE DIAMETER

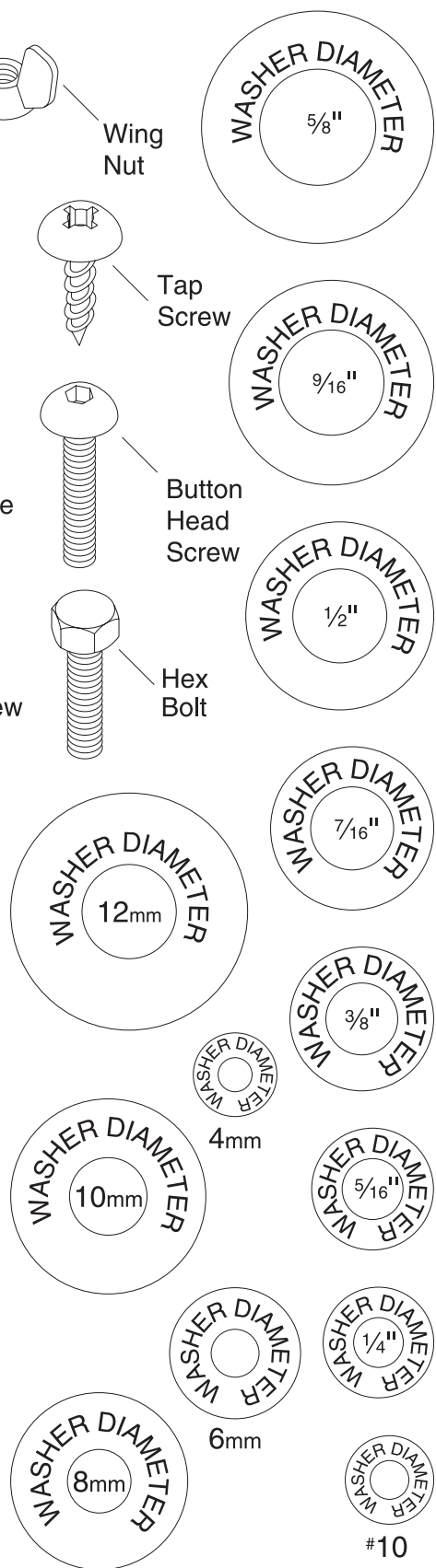

Cleanup

The unpainted surfaces of your machine are coated with a heavy-duty rust preventative that prevents corrosion during shipment and storage. This rust preventative works extremely well, but it will take a little time to clean.

Be patient and do a thorough job cleaning your machine. The time you spend doing this now will give you a better appreciation for the proper care of your machine's unpainted surfaces.

There are many ways to remove this rust preventative, but the following steps work well in a wide variety of situations. Always follow the manufacturer's instructions with any cleaning product you use and make sure you work in a well-ventilated area to minimize exposure to toxic fumes.

Before cleaning, gather the following:

- Disposable rags
- Cleaner/degreaser (WD-40 works well)
- Safety glasses & disposable gloves
- Plastic paint scraper (optional)

Basic steps for removing rust preventative:

1. Put on safety glasses.
2. Coat the rust preventative with a liberal amount of cleaner/degreaser, then let it soak for 5–10 minutes.
3. Wipe off the surfaces. If your cleaner/degreaser is effective, the rust preventative will wipe off easily. If you have a plastic paint scraper, scrape off as much as you can first, then wipe off the rest with the rag.
4. Repeat **Steps 2–3** as necessary until clean, then coat all unpainted surfaces with a quality metal protectant to prevent rust.

NOTICE

Avoid chlorine-based solvents, such as acetone or brake parts cleaner, that may damage painted surfaces.

Site Considerations

Weight Load

Refer to the **Machine Data Sheet** for the weight of your machine. Make sure that the surface upon which the machine is placed will bear the weight of the machine, additional equipment that may be installed on the machine, and the heaviest workpiece that will be used. Additionally, consider the weight of the operator and any dynamic loading that may occur when operating the machine.

Space Allocation

Consider the largest size of workpiece that will be processed through this machine and provide enough space around the machine for adequate operator material handling or the installation of auxiliary equipment. With permanent installations, leave enough space around the machine to open or remove doors/covers as required by the maintenance and service described in this manual.

Physical Environment

The physical environment where the machine is operated is important for safe operation and longevity of machine components. For best results, operate this machine in a dry environment that is free from excessive moisture, hazardous chemicals, airborne abrasives, or extreme conditions. Extreme conditions for this type of machinery are generally those where the ambient temperature range exceeds 41°–104°F; the relative humidity range exceeds 20%–95% (non-condensing); or the environment is subject to vibration, shocks, or bumps.

Electrical Installation

Place this machine near an existing power source. Make sure all power cords are protected from traffic, material handling, moisture, chemicals, or other hazards. Make sure to leave enough space around machine to disconnect power supply or apply a lockout/tagout device, if required.

Lighting

Lighting around the machine must be adequate enough that operations can be performed safely. Shadows, glare, or strobe effects that may distract or impede the operator must be eliminated.

Beginning Assembly

The machine must be fully assembled before it can be operated. Before beginning the assembly process, refer to **Needed for Setup** and gather all listed items. To ensure the assembly process goes smoothly, first clean any parts that are covered or coated in heavy-duty rust preventative (if applicable).

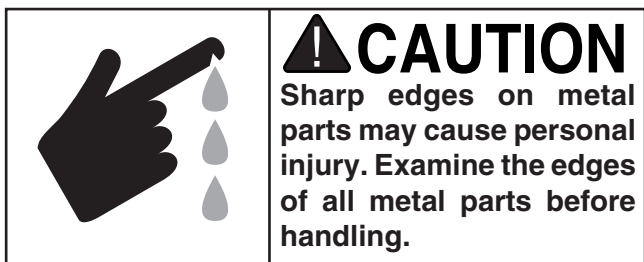
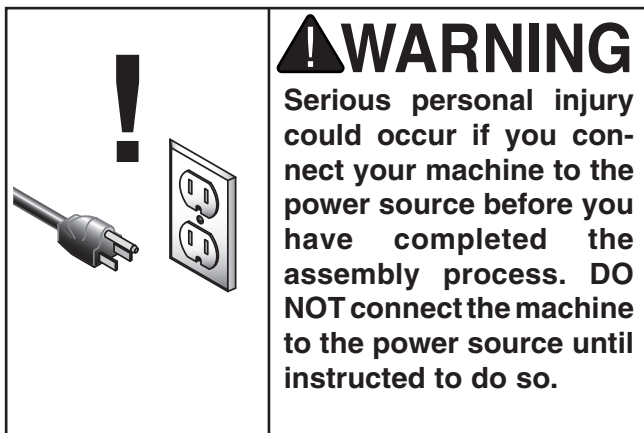
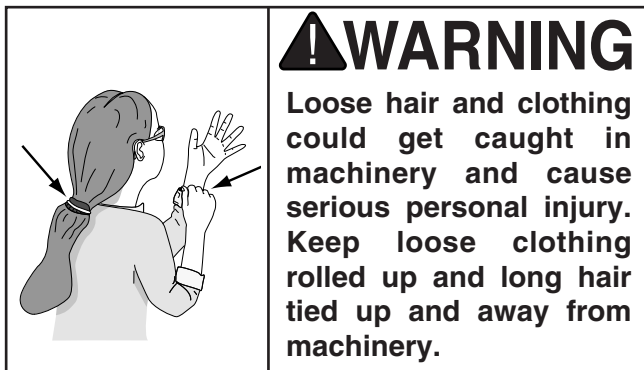

Cabinet Assembly

The Model G0529 Sander mounts on a sturdy cabinet stand.

To assemble the cabinet stand:

1. Connect all four panels together with (8) $\frac{5}{16}$ " -18 x $\frac{3}{4}$ " hex bolts, (8) $\frac{5}{16}$ " lock washers, (16) $\frac{5}{16}$ " flat washers, and (8) $\frac{5}{16}$ "-18 hex nuts (see **Figure 4**).



Figure 4. Assembled panels.

2. Using the $\frac{5}{16}$ " flat head screws, $\frac{5}{16}$ " washers and nuts, install (4) rubber feet, as shown in **Figure 5**.



Figure 5. Installing rubber feet.

Mounting Sander

When the cabinet has been completed, it is time to place the sander unit on top of the cabinet stand.

To mount the sander to the top of the cabinet stand:

1. With the help of an assistant, place the sander on the cabinet stand.

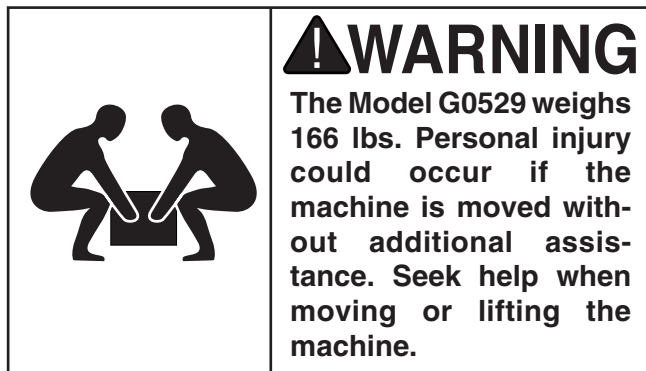

2. Align the holes on the rim of the cabinet sides with the threaded holes in the rim of the sander.
3. Secure the cabinet and the sander together with (2) $\frac{5}{16}$ "-18 x $\frac{3}{4}$ " hex bolts, (2) $\frac{5}{16}$ " lock washers, and (2) $\frac{5}{16}$ " flat washers, as shown in **Figure 6**.



Figure 6. Cabinet hole location.

Installing Spindle

To install the spindle onto the sander:

1. DISCONNECT MACHINE FROM POWER!
2. Select the proper diameter of spindle sleeve. The Model G0529 comes with the following four sizes of spindle sleeves:
 - $\frac{1}{4}$ "
 - $\frac{5}{8}$ "
 - 1 $\frac{1}{2}$ "
 - 2"
3. Make sure the tapered end of the spindle sleeve is clean before installing it into the sander spindle.
4. Use the supplied open end wrenches to secure the spindle as shown in **Figure 7**.

Note: Do not overtighten the spindle sleeve, it could make removal difficult.

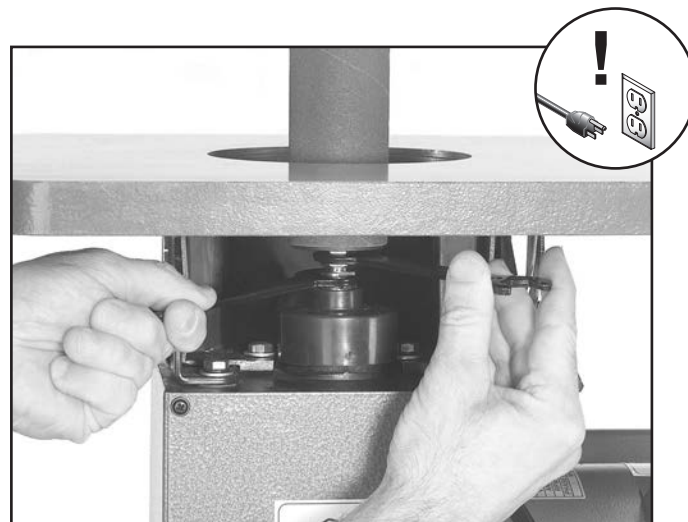

Figure 7. Installing spindle.

Table Inserts

The table inserts minimize the gap between the working surface edge and the spindle. It is important to use the proper table insert according to the diameter spindle you are using.

The Model G0529 comes with the following four table inserts:

- 2"
- 1"
- 2" elliptical
- 1" elliptical

Select the table insert that comes closest the spindle sleeve diameter without touching it. The elliptical inserts are used when sanding with the table tilted.

Place the table insert into the table hole, as shown in **Figure 8**.

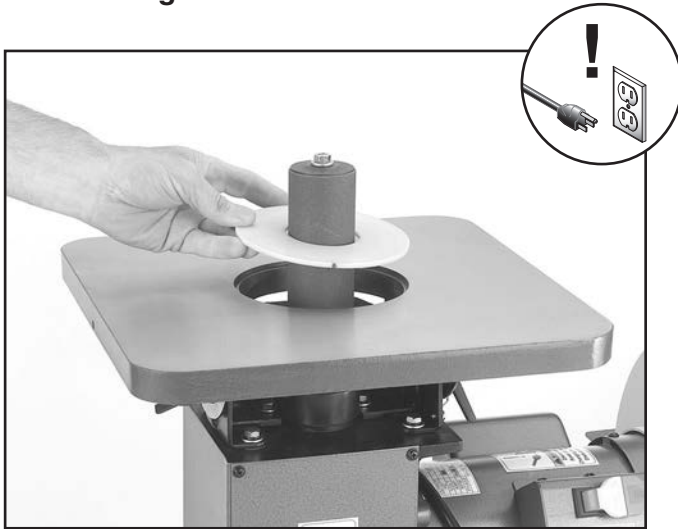

Figure 8. Installing table inserts.

Squaring Table

To square the sanding tables:

1. DISCONNECT MACHINE FROM POWER!
2. Set the table at 90°, as shown in **Figure 9**.

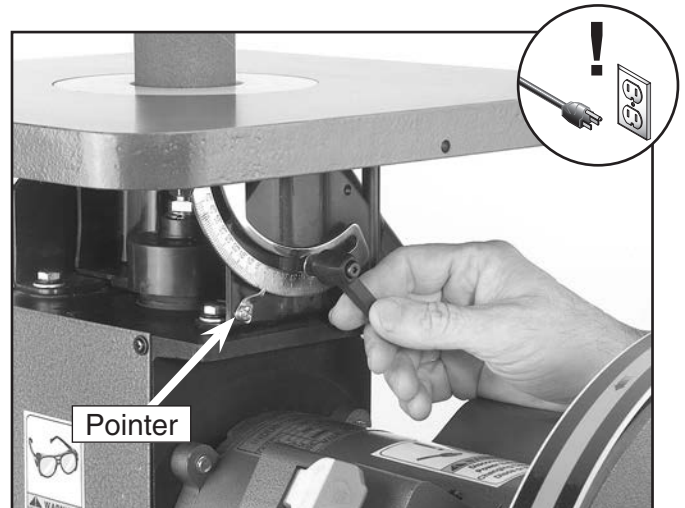

Figure 9. Setting the table scale at 90°.

3. Place a machinist's square on the table and against the sanding spindle to verify the table is 90° from the edge of the sanding sleeve as shown in **Figure 10**.
4. Adjust the pointer to 90°.



Figure 10. Squaring the table and spindle.

5. If the table is not 90° from the spindle, adjust the table stop bolt to allow more table travel, as shown in **Figure 11**.

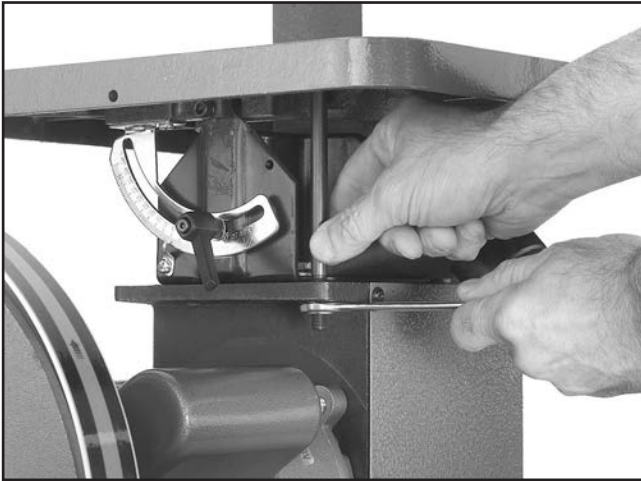

Figure 11. Squaring the sanding table.

6. Tighten the table stop bolt against the underside of the table when the table is set at 90°.

Squaring Disc Sander

The sanding tables for the spindle sander and the disc sander have tilting capabilities from 0° to 45°.

To tilt the sanding table:

1. DISCONNECT MACHINE FROM POWER!

2. Using a machinist's square, set one edge on the table surface and the other against the face of the sanding disc, as shown in **Figure 12**.

Note: This can be done with the sandpaper installed, although it is somewhat easier to measure if the disc does not have the sandpaper disc installed.

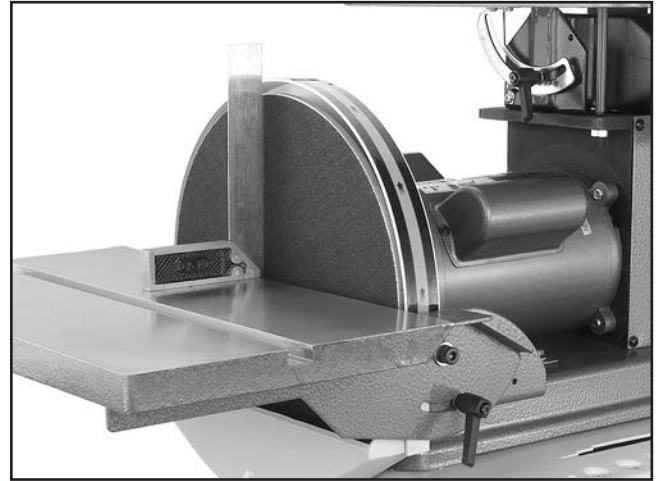

Figure 12. Squaring the disc sanding table.

3. Loosen the lock lever and adjust the table angle until it is perfectly perpendicular and flush with both edges of the machinist's square.
4. Tighten the lock lever while holding the table perpendicular.
5. Adjust the scale pointer to read 0° when the table has been properly adjusted.

Sanding Disc Installation

The disc sander requires 12" PSA (pressure sensitive adhesive) sanding discs.

To install a new sanding disc on the 12" disc sanding surface:

1. DISCONNECT MACHINE FROM POWER!
2. Peel off the old sanding disc, clean the disc surface with mineral spirit, then wipe it dry.
3. Remove protective layer of **one-half** of sandpaper backing and fold it against the remaining half.
4. Slip the half with the protective layer between the disc and the table edge (see **Figure 13** below).
5. Position the exposed adhesive on the upper half of the disc that extends above the table. Once it is positioned evenly on the disc, press the adhesive onto the surface.
6. Rotate the disc so the lower half is above the table. Peel off the remaining half of the protective paper and press sandpaper against disc.

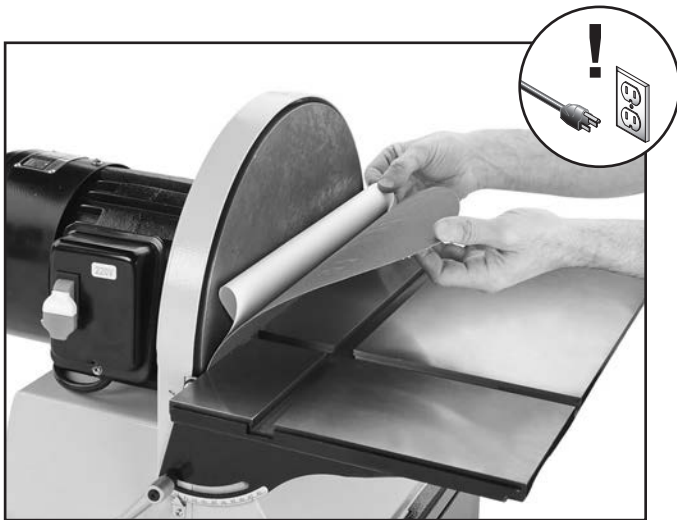

Figure 13. Example of installing PSA sanding disc.

Aligning Table

The table must be spaced evenly away from the face of the sanding disc so that the sandpaper does not rub against the table.

To align the table:

1. Loosen bolts securing table to the table support bracket.
2. Align the table so that there is a $\frac{1}{16}$ " gap between the 12" disc and the table.
3. Tighten the bolts loosened in **Step 1**.
4. Spin the disc by hand to check if the sandpaper is touching the table.

Note: *DO NOT turn the disc sander on at this point.*

5. Repeat **Steps 1-3** if the sandpaper touches table at any point in the rotation.

Miter Gauge

The miter gauge needs to be adjusted perpendicular to the face of the wheel when it is mounted in the table slot.

To adjust miter gauge:

1. Use a machinist's square with one edge against the face of the miter gauge and the other against the disc face, as shown in **Figure 14**.



Figure 14. Squaring miter gauge to disc.

2. Loosen the lock knob on the miter gauge to adjust it flush with the edge of the square.
3. Tighten the lock knob, and verify the setting.

Note: Sometimes the tightening procedure can affect the adjustment.

4. Loosen the set screw that secures the angle pointer and adjust the pointer to the 0° mark on the scale.
5. Retighten the set screw that secures the angle pointer.

Dust Collection

There are two 2" dust collection ports for the sander that should be connected to a dust collector. The ports are located under the sanding tables, as shown in **Figure 15**.

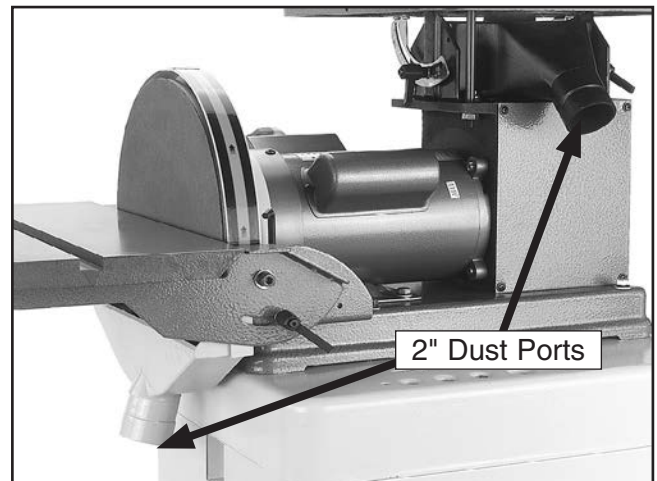

Figure 15. Dust port locations.

To connect your machine to a dust collection system:

1. Use a 2" diameter hose to connect a dust collection system to your dust ports.
2. Start the dust collection system before operating the sander.



SECTION 4: OPERATIONS

Operation Overview

The purpose of this overview is to provide the novice machine operator with a basic understanding of how the machine is used during operation, so the machine controls/components discussed later in this manual are easier to understand.

Due to the generic nature of this overview, it is **not** intended to be an instructional guide. To learn more about specific operations, read this entire manual, seek additional training from experienced machine operators, and do additional research outside of this manual by reading "how-to" books, trade magazines, or websites.

	<p>!WARNING To reduce your risk of serious injury, read this entire manual BEFORE using machine.</p>
--	--

<p>!WARNING To reduce risk of eye injury from flying chips or lung damage from breathing dust, always wear safety glasses and a respirator when operating this machine.</p>	
	

<p>NOTICE If you are not experienced with this type of machine, WE STRONGLY RECOMMEND that you seek additional training outside of this manual. Read books/magazines or get formal training before beginning any projects. Regardless of the content in this section, Grizzly Industrial will not be held liable for accidents caused by lack of training.</p>

Power Switch

The Model G0529 sander is equipped with a paddle-type power switch with a safety key.

To operate the power switch:

1. Insert the safety locking key shown in **Figure 16**.



Figure 16. On/Off Switch.

2. Lift the switch to start motor. Press switch to stop the motor.
3. Remove the locking key when the machine is not in use and store the key in a safe place.

<p>!WARNING Make sure power switch is in OFF position before connecting sander to power. Serious personal injury could occur if machine is connected to power with power switch ON.</p>
--

Spindle Sanding

The oscillating spindle sander on the Model G0529 produces an extremely fine sanding finish on edges or contours. The oscillation of the spindle disperses the material contact throughout the sanding sleeve to prevent burning.

To perform spindle sanding operations:

1. Check to make sure that the table insert has been installed correctly and the spindle is secured tightly.
2. Set the angle of the table relative to the sanding sleeve. Angle can be set with the angle gauge on the spindle sander table or with a protractor for greater accuracy.

Note: *The spindle sander table can be positioned from 0° to 45°, relative to the plane of the sanding surface.*

3. Make sure that the appropriate spindle has been selected for the intended operation and that it is installed properly.
4. Connect the sander to a dust-collection system.
5. Turn the power switch *ON* to start the spindle sander and begin sanding as shown in **Figure 17**.

DO NOT FORCE THE WORKPIECE AGAINST THE SANDING SLEEVE.

⚠WARNING

Never use the Model G0529 for applications other than those for which it was made. **DO NOT** overload the machine or use excess force when sanding. Severe personal injury, damage to the machine, or damage to your workpiece could occur.

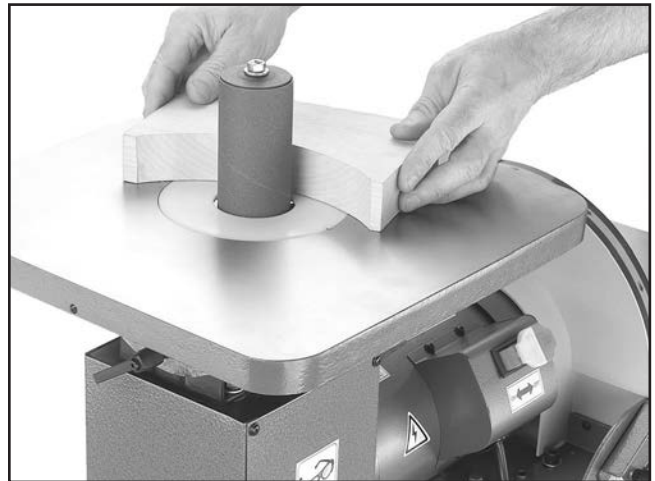

Figure 17. Spindle sanding.

Disc Sanding

To perform disc sanding operations:

1. Set the angle of the table relative to the sanding disc. Angle can be set with the angle gauge on the disc sander or with a protractor for greater accuracy.

Note: *The disc table can be positioned from 0° to 45°, relative to the plane of the sanding surface.*

2. Once the desired table angle has been set, move the table towards the sanding disc to decrease the gap between the table and the disc. The gap should be $\frac{1}{16}$ " maximum.
3. To sand straight edges, firmly hold the side of workpiece against the miter gauge (set at 0°), with the other surface against the face of the disc (see **Figure 18**).

Note: *For sanding curves or irregular shapes, remove the miter gauge from the disc table. Always keep the workpiece on the side of the wheel that is rotating down toward the table. This will keep the workpiece from flying out of your hands from the rotational forces.*



Figure 18. Disc sanding with table tilted.

Miter Sanding

The most efficient way to get a perfect miter is to cut the workpiece slightly long and sand it to the desired dimension. Miter sanding can be done easily with the miter gauge.

To perform miter sanding operations:

1. Loosen the knob on the miter gauge, adjust the angle to the desired point, and tighten the knob.
2. Slide the miter gauge into its slot and use it to hold your workpiece in position (see **Figure 19**).

Note: *The miter gauge can be used in either direction in the slot to achieve the proper relation of the workpiece to the disc.*



Figure 19. Disc sanding with miter.

SECTION 5: ACCESSORIES

!WARNING

Installing unapproved accessories may cause machine to malfunction, resulting in serious personal injury or machine damage. To reduce this risk, only install accessories recommended for this machine by Grizzly.

NOTICE

Refer to our website or latest catalog for additional recommended accessories.

PRO-STICK® Abrasive Surface Cleaners

Extend the life of your sanding discs and sleeves!

Size	Model
1½" X 1½" X 8½"	W1306
2" X 2" X 12"	W1307



Figure 20. PRO-STICK® abrasive cleaners.

Aluminum Oxide Sanding Sleeves

MODEL	TYPE	GRIT
H6659	¼" x 5½"	60
H6660	¼" x 5½"	80
H6661	¼" x 5½"	100
H6662	¼" x 5½"	120
H6663	¼" x 5½"	150
H6664	⅝" x 5½"	60
H6665	⅝" x 5½"	80
H6666	⅝" x 5½"	100
H6667	⅝" x 5½"	120
H6668	⅝" x 5½"	150
H6669	1½" x 5½"	60
H6670	1½" x 5½"	80
H6671	1½" x 5½"	100
H6672	1½" x 5½"	120
H6673	1½" x 5½"	150
H6674	2" x 5½"	60
H6675	2" x 5½"	80
H6676	2" x 5½"	100
H6677	2" x 5½"	120
H6678	2" x 5½"	150

12" Aluminum Oxide Sanding Discs

MODEL	TYPE	GRIT
D1335	12" PSA	60
D1336	12" PSA	80
D1337	12" PSA	100
D1338	12" PSA	120
D1339	12" PSA	150
D1340	12" PSA	180
D1341	12" PSA	220

order online at www.grizzly.com or call 1-800-523-4777

Model G0529 (Mfd. Since 04/17)

SECTION 6: MAINTENANCE

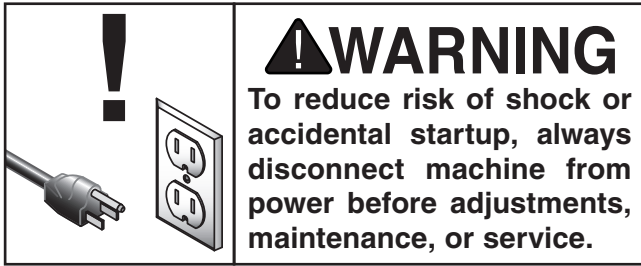

Schedule

For optimum performance from your machine, follow this maintenance schedule and refer to any specific instructions given in this section.

Daily Check

- Loose mounting bolts.
- Damaged sanding disc/sleeve.
- Worn or damaged wires.
- Any other unsafe condition.

After Each Use

- Wipe off the sawdust build-up from the table surface.
- Turn off power switch and remove the switch key.
- Check for spindle straightness.

Weekly Maintenance

- Wipe a lubricant such as SLIPIT® onto the table.
- All the bearings are permanently lubricated and require no additional lubrication

Monthly Check

- Keep unpainted surfaces rust free with products such as Boeshield® T-9.

Cleaning & Protecting

Cleaning the Model G0529 is relatively easy. Vacuum excess wood chips and sawdust, and wipe off the remaining dust with a dry cloth. If any resin has built up, use a resin dissolving cleaner to remove it.

Protect the unpainted cast iron table by wiping it clean after every use—this ensures moisture from wood dust does not remain on bare metal surfaces. Keep the table rust-free with regular applications of products like G96® Gun Treatment, SLIPIT®, or Boeshield® T-9 (see **Accessories** for more details).

SECTION 7: SERVICE

Review the troubleshooting and procedures in this section if a problem develops with your machine. If you need replacement parts or additional help with a procedure, call our Technical Support. **Note:** *Please gather the serial number and manufacture date of your machine before calling.*

Troubleshooting

Motor & Electrical

Symptom	Possible Cause	Possible Solution
Motor will not start.	<ol style="list-style-type: none"> 1. Low voltage. 2. Open circuit in motor or loose connections. 	<ol style="list-style-type: none"> 1. Check power line for proper voltage. 2. Inspect all lead connections on motor for loose or open connections.
Motor will not start; fuses or circuit breakers blow.	<ol style="list-style-type: none"> 1. Short circuit in line cord or plug. 2. Short circuit in motor or loose connections. 3. Incorrect fuses or circuit breakers in power line. 	<ol style="list-style-type: none"> 1. Inspect cord or plug for damaged insulation and shorted wires. 2. Inspect all connections on motor for loose or shorted terminals or worn insulation. 3. Install correct fuses or circuit breakers.
Motor overheats.	<ol style="list-style-type: none"> 1. Motor overloaded. 2. Incorrect usage of machine. 3. Air circulation through motor restricted. 	<ol style="list-style-type: none"> 1. Reduce load on motor. 2. Reduce the applied load on the machine. 3. Clean out motor to provide normal air circulation.
Motor stalls (resulting in blown fuses or tripped circuit).	<ol style="list-style-type: none"> 1. Short circuit in motor or loose connections. 2. Low voltage. 3. Incorrect fuses or circuit breakers in power line. 4. Motor overloaded. 	<ol style="list-style-type: none"> 1. Inspect connections on motor for loose or shorted terminals or worn insulation. 2. Correct low voltage conditions. 3. Install correct fuses or circuit breakers. 4. Reduce load on motor.

Machine Operation

Symptom	Possible Cause	Possible Solution
Grains easily rub off the sleeve or disc.	<ol style="list-style-type: none"> 1. Sanding sleeve/disc has been stored in an incorrect environment. 2. Sanding sleeve/disc has been smashed or folded. 	<ol style="list-style-type: none"> 1. Store sanding sleeve/disc away from extremely hot or dry temperatures. 2. Store sanding sleeve/disc flat not bent or folded.
Deep sanding grooves or scars in workpiece.	<ol style="list-style-type: none"> 1. Sanding sleeve/disc grit is too coarse for the desired finish. 2. Workpiece sanded across grain. 3. Too much sanding force on workpiece. 4. Workpiece held still against sleeve/disc. 	<ol style="list-style-type: none"> 1. Use a finer grit sanding sleeve/disc. 2. Sand with grain. 3. Reduce pressure on workpiece while sanding. 4. Keep workpiece moving while sanding on sleeve/disc.
Sanding surface clogs quickly or burns.	<ol style="list-style-type: none"> 1. Too much pressure against sleeve/disc. 2. Sanding softwood. 	<ol style="list-style-type: none"> 1. Reduce pressure on workpiece while sanding. 2. Use different stock. Or, accept characteristics of the and plan on cleaning/replacing sleeves frequently.

Machine Operation (Continued)

Symptom	Possible Cause	Possible Solution
Glazed sanding surfaces.	<ol style="list-style-type: none"> 1. Sanding wet stock. 2. Sanding stock with high residue. 	<ol style="list-style-type: none"> 1. Dry stock properly before sanding. 2. Use different stock. Or, accept the characteristics of the stock and plan on cleaning/replacing sleeves/discs frequently.
Burn marks on workpiece.	<ol style="list-style-type: none"> 1. Using too fine of sanding grit. 2. Using too much pressure. 3. Work held still for too long. 	<ol style="list-style-type: none"> 1. Use coarser grit sanding sleeve/disc. 2. Reduce pressure on workpiece while sanding. 3. Do not keep workpiece in one place for too long.
Machine slows when operating.	<ol style="list-style-type: none"> 1. Applying too much pressure to workpiece. 2. Undersized circuit or extension cord used. 	<ol style="list-style-type: none"> 1. Sand with less pressure—let the movement of the sleeve/disc do the work. 2. Make sure circuit wires are proper gauge & don't use extension cords!
Machine vibrates excessively.	<ol style="list-style-type: none"> 1. Stand not stable on floor. 2. Incorrect motor mounting. 3. Incorrect sanding sleeve tension. 4. Broken/defective sanding sleeve/disc. 	<ol style="list-style-type: none"> 1. Secure stand to floor, reposition to level surface, or shim stand. 2. Check/adjust motor mounting. 3. Make sure tension lever is in tensioning position. Follow sleeve tensioning instructions in this manual. 4. Replace sanding sleeve/disc.
Workpiece frequently gets pulled out of your hand.	<ol style="list-style-type: none"> 1. Not supporting workpiece against stable. 2. Starting the workpiece on a leading corner. 	<ol style="list-style-type: none"> 1. Use table to support workpiece. 2. Start workpiece on a trailing corner.

SECTION 8: WIRING

These pages are current at the time of printing. However, in the spirit of improvement, we may make changes to the electrical systems of future machines. Compare the manufacture date of your machine to the one stated in this manual, and study this section carefully.

If there are differences between your machine and what is shown in this section, call Technical Support at (570) 546-9663 for assistance BEFORE making any changes to the wiring on your machine. An updated wiring diagram may be available. **Note:** *Please gather the serial number and manufacture date of your machine before calling. This information can be found on the main machine label.*

WARNING

Wiring Safety Instructions

SHOCK HAZARD. Working on wiring that is connected to a power source is extremely dangerous. Touching electrified parts will result in personal injury including but not limited to severe burns, electrocution, or death. Disconnect the power from the machine before servicing electrical components!

MODIFICATIONS. Modifying the wiring beyond what is shown in the diagram may lead to unpredictable results, including serious injury or fire. This includes the installation of unapproved after-market parts.

WIRE CONNECTIONS. All connections must be tight to prevent wires from loosening during machine operation. Double-check all wires disconnected or connected during any wiring task to ensure tight connections.

CIRCUIT REQUIREMENTS. You MUST follow the requirements at the beginning of this manual when connecting your machine to a power source.

WIRE/COMPONENT DAMAGE. Damaged wires or components increase the risk of serious personal injury, fire, or machine damage. If you notice that any wires or components are damaged while performing a wiring task, replace those wires or components.

MOTOR WIRING. The motor wiring shown in these diagrams is current at the time of printing but may not match your machine. If you find this to be the case, use the wiring diagram inside the motor junction box.















CAPACITORS/INVERTERS. Some capacitors and power inverters store an electrical charge for up to 10 minutes after being disconnected from the power source. To reduce the risk of being shocked, wait at least this long before working on capacitors.

EXPERIENCING DIFFICULTIES. If you are experiencing difficulties understanding the information included in this section, contact our Technical Support at (570) 546-9663.

NOTICE

The photos and diagrams included in this section are best viewed in color. You can view these pages in color at www.grizzly.com.

COLOR KEY

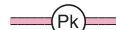
BLACK 	BLUE 	YELLOW 	LIGHT BLUE 
WHITE 	BROWN 	YELLOW GREEN 	BLUE WHITE 
GREEN 	GRAY 	PURPLE 	TURQUOISE 
RED 	ORANGE 	PINK 	

Wiring Diagram

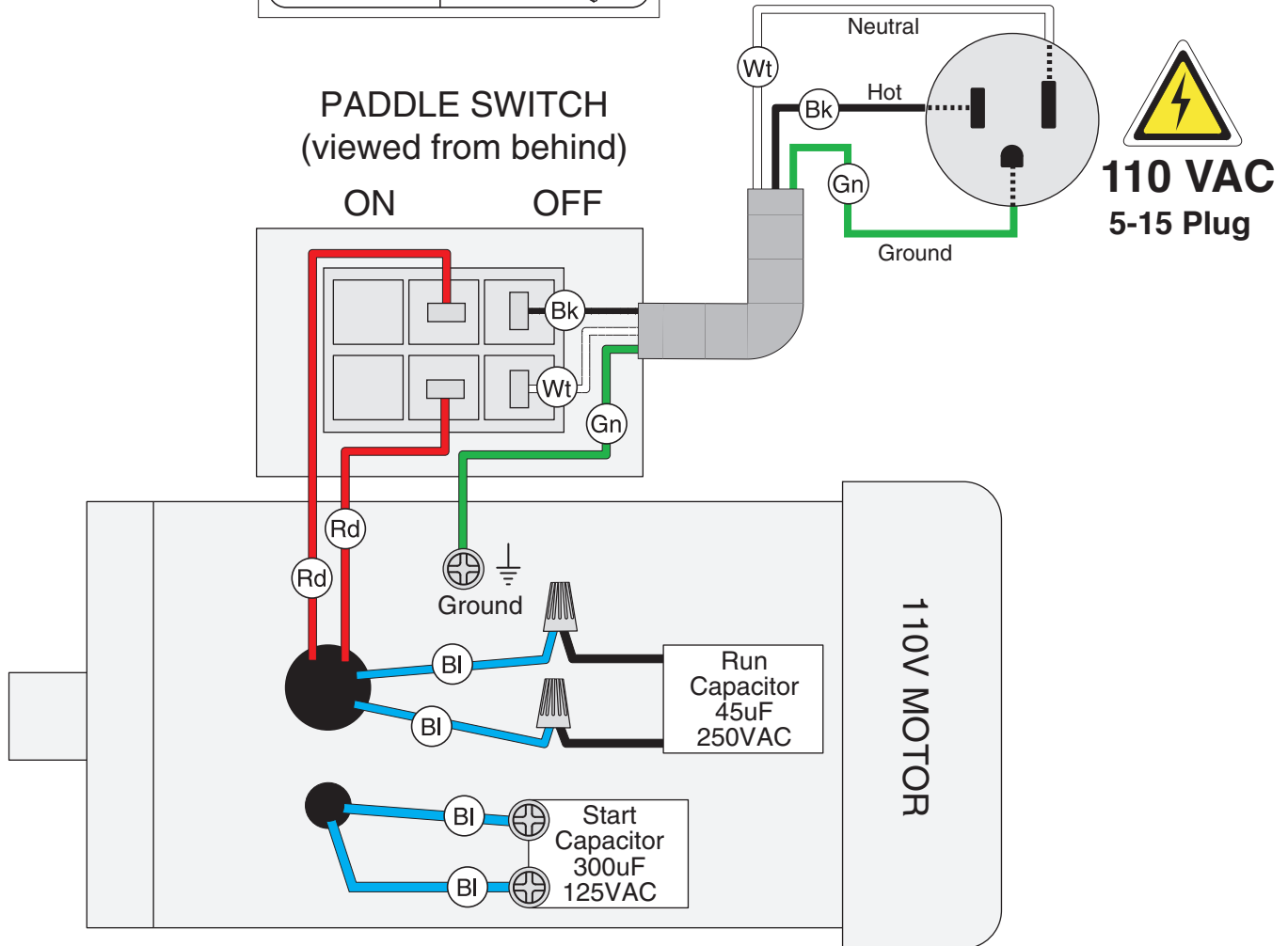

NOTICE

The motor wiring shown here is current at the time of printing, but it may not match your machine. Always use the wiring diagram inside the motor junction box.

SECTION 9: PARTS

We do our best to stock replacement parts when possible, but we cannot guarantee that all parts shown are available for purchase. Call (800) 523-4777 or visit www.grizzly.com/parts to check for availability.

Frame Breakdown

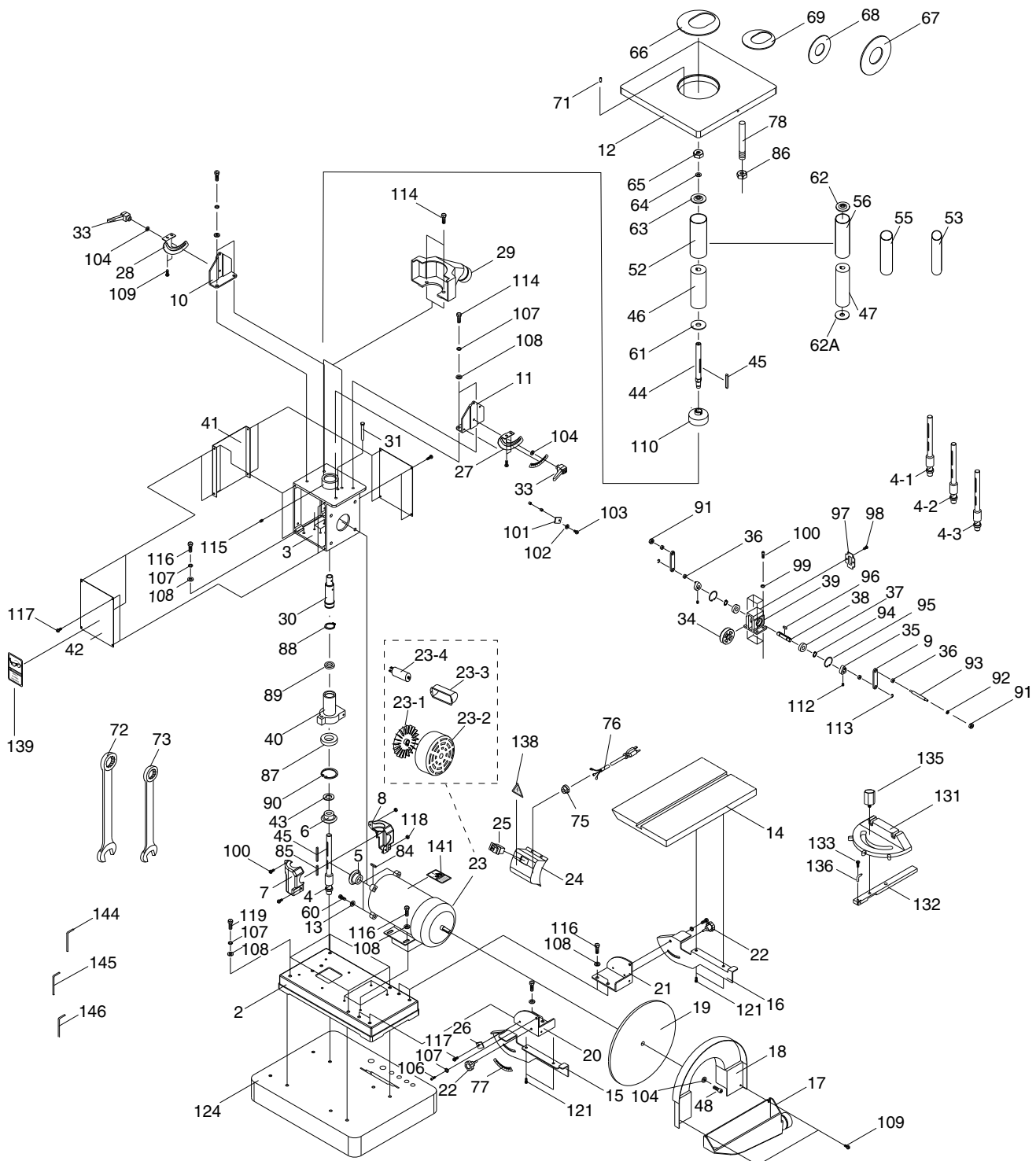

Main Parts List

REF	PART #	DESCRIPTION
2	P0529002	BASE UPPER
3	P0529003	FRAME
4	P0529004	SPINDLE 2"
4-1	P0529004-1	SPINDLE 1-1/2"
4-2	P0529004-2	SPINDLE 5/8"
4-3	P0529004-3	SPINDLE 1/4"
5	P0529005	HELICAL BEVEL GEAR
6	P0529006	PU HELICAL BEVEL GEAR
7	P0529007	RIGHT OIL BOX
8	P0529008	LEFT OIL BOX
9	P0529009	CONNECTION ROD
10	P0529010	RIGHT BRACKET
11	P0529011	LEFT BRACKET
12	P0529012	WORKING TABLE
13	P0529013	FLAT WASHER 3/8
14	P0529014	WORKING TABLE
15	P0529015	FRONT GRADUATED SCALE
16	P0529016	REAR GRADUATED SCALE
17	P0529017	DUST HOOD
18	P0529018	DISC GUARD
19	P0529019	DISC
20	P0529020	FRONT BRACKET
21	P0529021	REAR BRACKET
22	P0529022	HAND KNOB
23	P0529023	MOTOR 1 HP
23-1	P0529023-1	MOTOR FAN
23-2	P0529023-2	FAN COVER
23-3	P0529023-3	CAPACITOR COVER
23-4	P0529023-4	CAPACITOR
24	P0529024	SWITCH BOX
25	P0529025	PADDLE SWITCH WITH KEY
26	P0529026	INDICATOR
27	P0529027	RIGHT TRUNNION W/SCALE
28	P0529028	LEFT TRUNNION
29	P0529029	DUST HOOD
30	P0529030	SPINDLE
31	P0529031	GUIDE ROD
33	P0529033	HANDLE
34	P0529034	WORM GEAR
35	P0529035	CAM
36	P0529036	COPPER SLEEVE
37	P0529037	BALL BEARING 6001ZZ
38	P0529038	WORM GEAR SHAFT
39	P0529039	WORM GEAR HOUSING
40	P0529040	CONNECTION PIECE
41	P0529041	SIDE COVER
42	P0529042	FRONT AND REAR COVER
43	P0529043	SPACER
44	P0529044	ARBOR 5/8

REF	PART #	DESCRIPTION
45	P0529045	KEY 5 X 5 X 50
46	P0529046	RUBBER PAD 2
47	P0529047	RUBBER PAD 1- 1/2
48	P0529048	CAP SCREW 1/4-20 X 3/4
52	P0529052	SANDING SLEEVE 2
53	P0529053	SANDING SLEEVE 1/4
55	P0529055	SANDING SLEEVE 5/8
56	P0529056	SANDING SLEEVE 1-1/2
60	P0529060	HEX BOLT M10-1.5 X 25
61	P0529061	LOWER FLANGE 2"
62	P0529062	UPPER FLANGE 1-1/2"
62A	P0529062A	LOWER FLANGE 1-1/2"
63	P0529063	UPPER FLANGE 2"
64	P0529064	FLAT WASHER 5/16
65	P0529065	HEX NUT 5/16-18 (LH)
66	P0529066	ELLIPTICAL TABLE INSERT 2"
67	P0529067	ROUND TABLE INSERT 2"
68	P0529068	ROUND TABLE INSERT 3/4"
69	P0529069	ELLIPTICAL TABLE INSERT 3/4"
71	P0529071	ROLL PIN 3 X 12
72	P0529072	WRENCH 14 X 17
73	P0529073	COMBO WRENCH 12/14MM
75	P0529075	STRAIN RELIEF BUSHING
76	P0529076	POWER CORD
77	P0529077	GRADUATED SCALE
78	P0529078	POSITIONING ROD
84	P0529084	KEY 5 X 5 X 15
85	P0529085	KEY 6 X 6 X 30
86	P0529086	HEX NUT 3/8-16
87	P0529087	BALL BEARING 6006ZZ
88	P0529088	EXT RETAINING RING 28MM
89	P0529089	BALL BEARING 6804ZZ
90	P0529090	INT RETAINING RING 60MM
91	P0529091	LOCK NUT M5-.8
92	P0529092	WASHER 5MM
93	P0529093	CONNECTION SHAFT
94	P0529094	EXT RETAINING RING 12MM
95	P0529095	INT RETAINING RING 28MM
96	P0529096	KEY 4 X 4 X15
97	P0529097	REAR OIL COVER
98	P0529098	PHLP HD SCR 10-24 X 1/4
99	P0529099	LOCK WASHER 6MM
100	P0529100	CAP SCREW M6-1 X 15
101	P0529101	POINTER
102	P0529102	LOCK WASHER 5MM
103	P0529103	PHLP HD SCR M5-.8 X 25
104	P0529104	FLAT WASHER 1/4
106	P0529106	HEX BOLT 5/16-18 X 3/4
107	P0529107	LOCK WASHER 5/16

Main Parts List (Continued)

REF	PART #	DESCRIPTION
108	P0529108	FLAT WASHER 5/16
109	P0529109	CAP SCREW M5-.8 X 12
110	P0529110	COVER
112	P0529112	SET SCREW M4-.7 X 5
113	P0529113	E-CLIP 4MM
114	P0529114	HEX BOLT M8-1.25 X 25
115	P0529115	SETSCREW M6-1 X 5
116	P0529116	HEX BOLT 5/16-18 X 3/4
117	P0529117	PHLP HD SCR 10-24 X 3/8
118	P0529118	HEX NUT M6-1
119	P0529119	HEX BOLT 5/16-18 X 3
121	P0529121	HEX BOLT 1/4-20 X 1/2

REF	PART #	DESCRIPTION
124	P0529124	STAND TOP
131	P0529131	MITER GAUGE BODY
132	P0529132	MITER GAUGE BAR
133	P0529133	PHLP HD SCR 10-24 X 3/8
135	P0529135	MITER GAUGE KNOB
136	P0529136	POINTER
138	P0529138	WARNING LABEL-ELECTRICITY
139	P0529139	WARNING LABEL-GLASSES
141	P0529141	WARNING LABEL-DISCONNECT
144	P0529144	HEX WRENCH 4MM
145	P0529145	HEX WRENCH 5MM
146	P0529146	HEX WRENCH 6MM

Cabinet Breakdown

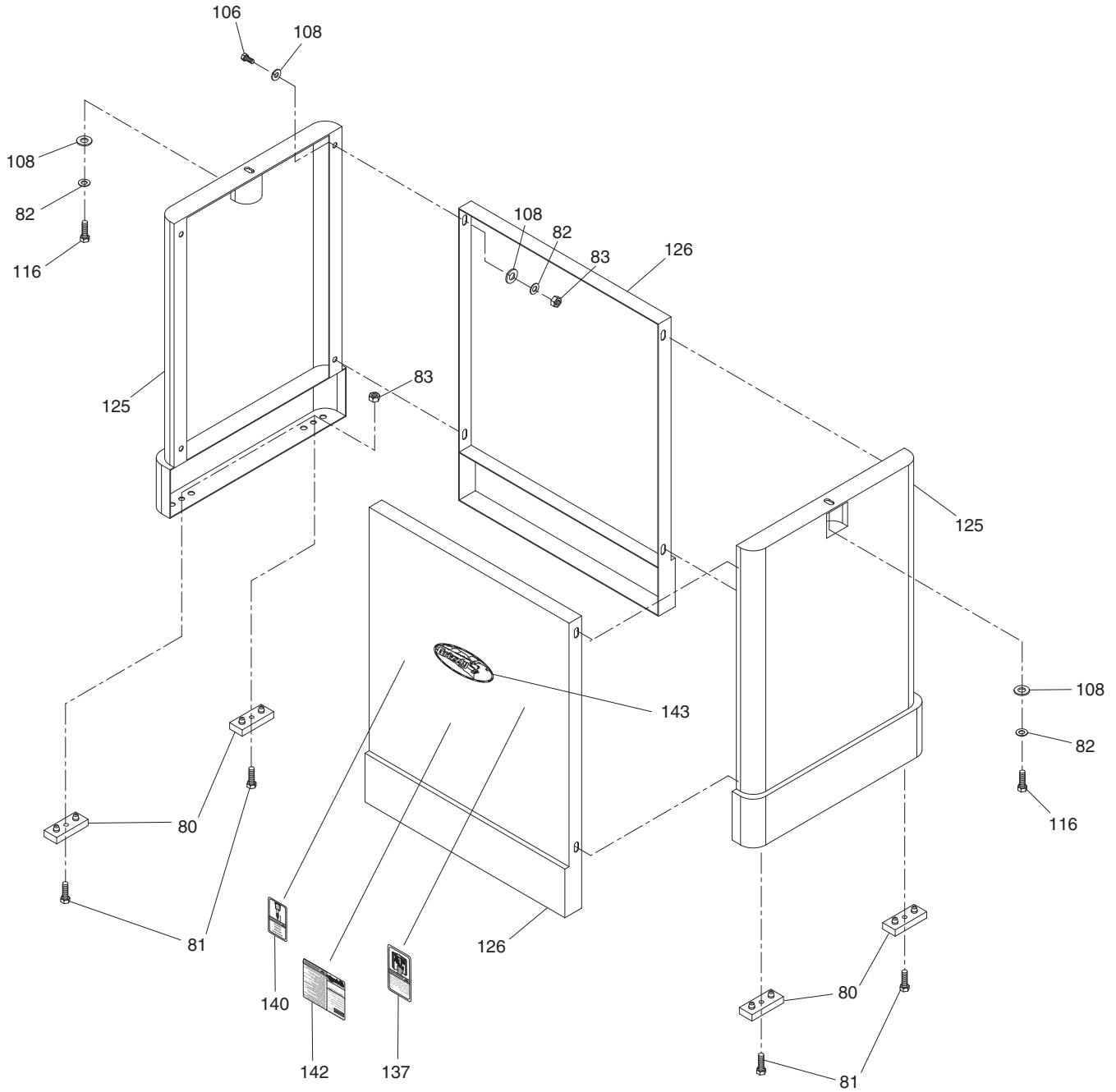

REF	PART #	DESCRIPTION
80	P0529080	PAD
81	P0529081	FLAT HD SCR 5/16-18 X 3/4
82	P0529082	LOCK WASHER 5/16
83	P0529083	HEX NUT 5/16-18
106	P0529106	HEX BOLT 5/16-18 X 3/4
108	P0529108	FLAT WASHER 5/16
116	P0529116	HEX BOLT 5/16-18 X 3/4

REF	PART #	DESCRIPTION
125	P0529125	RIGHT OR LEFT PANEL
126	P0529126	FRONT OR REAR PANEL
137	P0529137	WARNING LABEL-READ MANUAL
140	P0529140	WARNING LABEL-DUST MASK
142	P0529142	MACHINE ID LABEL
143	P0529143	GRIZZLY LOGO



WARRANTY CARD

Name _____
 Street _____
 City _____ State _____ Zip _____
 Phone # _____ Email _____
 Model # _____ Order # _____ Serial # _____

The following information is given on a voluntary basis. It will be used for marketing purposes to help us develop better products and services. **Of course, all information is strictly confidential.**

1. How did you learn about us?

Advertisement Friend Catalog
 Card Deck Website Other:

2. Which of the following magazines do you subscribe to?

<input type="checkbox"/> Cabinetmaker & FDM	<input type="checkbox"/> Popular Science	<input type="checkbox"/> Wooden Boat
<input type="checkbox"/> Family Handyman	<input type="checkbox"/> Popular Woodworking	<input type="checkbox"/> Woodshop News
<input type="checkbox"/> Hand Loader	<input type="checkbox"/> Precision Shooter	<input type="checkbox"/> Woodsmith
<input type="checkbox"/> Handy	<input type="checkbox"/> Projects in Metal	<input type="checkbox"/> Woodwork
<input type="checkbox"/> Home Shop Machinist	<input type="checkbox"/> RC Modeler	<input type="checkbox"/> Woodworker West
<input type="checkbox"/> Journal of Light Cont.	<input type="checkbox"/> Rifle	<input type="checkbox"/> Woodworker's Journal
<input type="checkbox"/> Live Steam	<input type="checkbox"/> Shop Notes	<input type="checkbox"/> Other:
<input type="checkbox"/> Model Airplane News	<input type="checkbox"/> Shotgun News	
<input type="checkbox"/> Old House Journal	<input type="checkbox"/> Today's Homeowner	
<input type="checkbox"/> Popular Mechanics	<input type="checkbox"/> Wood	

3. What is your annual household income?

\$20,000-\$29,000 \$30,000-\$39,000 \$40,000-\$49,000
 \$50,000-\$59,000 \$60,000-\$69,000 \$70,000+

4. What is your age group?

20-29 30-39 40-49
 50-59 60-69 70+

5. How long have you been a woodworker/metalworker?

0-2 Years 2-8 Years 8-20 Years 20+ Years

6. How many of your machines or tools are Grizzly?

0-2 3-5 6-9 10+

7. Do you think your machine represents a good value? Yes No

8. Would you recommend Grizzly Industrial to a friend? Yes No

9. Would you allow us to use your name as a reference for Grizzly customers in your area?

Note: We never use names more than 3 times. Yes No

10. Comments: _____

CUT ALONG DOTTED LINE

FOLD ALONG DOTTED LINE



Place
Stamp
Here



GRIZZLY INDUSTRIAL, INC.
P.O. BOX 2069
BELLINGHAM, WA 98227-2069



FOLD ALONG DOTTED LINE

Send a Grizzly Catalog to a friend:

Name _____

Street _____

City _____ State _____ Zip _____

TAPE ALONG EDGES--PLEASE DO NOT STAPLE

WARRANTY & RETURNS

Grizzly Industrial, Inc. warrants every product it sells for a period of **1 year** to the original purchaser from the date of purchase. This warranty does not apply to defects due directly or indirectly to misuse, abuse, negligence, accidents, repairs or alterations or lack of maintenance. This is Grizzly's sole written warranty and any and all warranties that may be implied by law, including any merchantability or fitness, for any particular purpose, are hereby limited to the duration of this written warranty. We do not warrant or represent that the merchandise complies with the provisions of any law or acts unless the manufacturer so warrants. In no event shall Grizzly's liability under this warranty exceed the purchase price paid for the product and any legal actions brought against Grizzly shall be tried in the State of Washington, County of Whatcom.

We shall in no event be liable for death, injuries to persons or property or for incidental, contingent, special, or consequential damages arising from the use of our products.

To take advantage of this warranty, contact us by mail or phone and give us all the details. We will then issue you a "Return Number," which must be clearly posted on the outside as well as the inside of the carton. We will not accept any item back without this number. Proof of purchase must accompany the merchandise.

The manufacturers reserve the right to change specifications at any time because they constantly strive to achieve better quality equipment. We make every effort to ensure that our products meet high quality and durability standards and we hope you never need to use this warranty.

Please feel free to write or call us if you have any questions about the machine or the manual.

Thank you again for your business and continued support. We hope to serve you again soon.

grizzly.com[®]
TOOL WEBSITE

Buy Direct and Save with Grizzly[®] – Trusted, Proven and a Great Value!
~Since 1983~

*Visit Our Website Today For
Current Specials!*

**ORDER
24 HOURS A DAY!
1-800-523-4777**

