

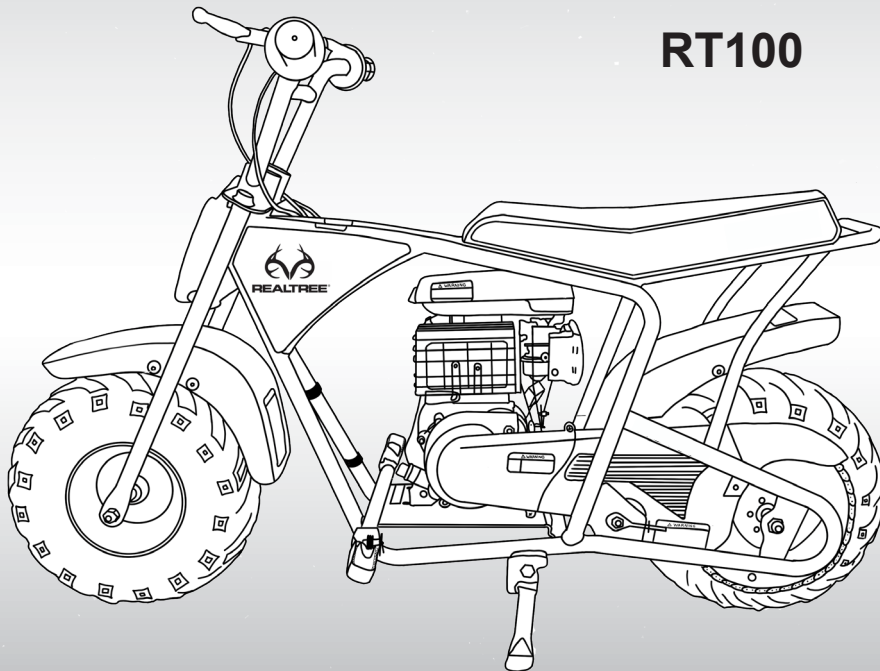

# OWNER'S MANUAL

RT100



**RECOMMENDED AGE 13+**

PROVINCIAL/ MUNICIPAL GOVERNMENTS HAVE DIFFERENT REGULATIONS PERTAINING TO OWNING AND OPERATING AN OFF-ROAD VEHICLE. LEARN THE REGULATIONS IN YOUR AREA.

Coleman Powersports  
(888) 405-8725  
1775 E. University Dr. Tempe, AZ 85281  
[www.colemanpowersportsusa.com](http://www.colemanpowersportsusa.com)



## **WARNING**

Operating, servicing and maintaining a passenger vehicle or off-road vehicle can expose you to chemicals including engine exhaust, carbon monoxide, phthalates, and lead, which are known to the state of California to cause cancer and birth defects or other reproductive harm. To minimize exposure, avoid breathing exhaust, do not idle the engine except as necessary, service your vehicle in a well-ventilated area and wear gloves or wash your hands frequently when servicing your vehicle. For more information go to [www.P65Warnings.ca.gov/passenger-vehicle](http://www.P65Warnings.ca.gov/passenger-vehicle)



## **To the Owner**

Congratulations on your purchase of a Coleman Powersports Off-Road Mini Bike. This Owner's/Operator's manual will provide you information regarding safe operation, operational instructions, maintenance and care. Fully understanding this manual and following all of the instructions here in will provide the knowledge needed to have safe and enjoyable operation.

For questions regarding operation and maintenance of this Off-Road mini bike, please call Coleman Powersports toll free 888-405-8725.

### **Safety - Notice to parents**

The recommended age for operating this Mini Bike is 13 and over. Even though a child may meet the minimum recommended age, children differ in skills, physical abilities, and judgment. Some children may not be able to operate a Mini Bike safely. Parents should permit continued use only if they determine that the child has the ability to operate the Mini Bike in a safe manner.

Continual adult supervision is required for children under the age of 16.

**THIS MINI BIKE IS NOT A TOY AND COULD BE HAZARDOUS TO OPERATE.**

### **Reading the Owner's/ Operator's Manual**

It is important this manual is read from cover to cover carefully by the owner and all operators.

This Owner's/ Operator's manual should be a permanent part of the mini bike and should remain with the vehicle at all times. The manual should also remain with the vehicle if sold.

To emphasize special important information in the manual, please note the following:

 This is the alert symbol. The symbol means **ATTENTION!, BECOME ALERT!, YOUR SAFETY IS INVOLVED.**

To emphasize important safety information, the word **WARNING**, with the alert symbol, has special meaning:

 **WARNING** Indicates a potential hazard that could result in **SEVERE INJURY** or **DEATH** to the operator, by stander or person inspecting or repairing the unit.

To emphasize important information, the word **CAUTION** has special meaning.:

**CAUTION:** Indicates special precautions that must be taken to avoid damage to the unit.

To emphasize important information, the word **NOTE** has special meaning.:

**NOTE:** Indicates key information to make procedures easier or clearer to understand.

 **WARNING** or **CAUTION**

<p>The first part will identify a <b>POTENTIAL HAZARD</b>.</p> <p>The second part will describe <b>WHAT COULD HAPPEN</b> if the warning or caution is ignored.</p> <p>The third part will describe <b>HOW TO AVOID THE HAZARD</b>.</p>
----------------------------------------------------------------------------------------------------------------------------------------------------------------------------------------------------------------------------------------

Coleman Powersports is concerned about the environment and believes in conserving and protecting all natural resources. For this reason, owners should recycle, trade in, or dispose as appropriate, oil and tires.

This manual is based on the latest product information available at the time of publication. Coleman Powersports has a policy of continually improving its products. Due to improvements, or other changes, there may be some discrepancies. We reserve the right to make product changes at any time, without notice and without incurring any obligation to make the same or similar changes to vehicles previously built or sold.

# TABLE OF CONTENTS

COLEMAN POWERSPORTS WARRANTY.....	2	CHAIN AND SPROCKET.....	23
IMPORTANT SAFETY LABELS.....	4	INSPECTION.....	23
LOCATION.....	4	TENSION AND ADJUSTMENT.....	23
LABELS.....	5	CLEANING AND LUBRICATION..	23
SAFETY.....	6	CLEANING AND INSPECTING	
DESCRIPTION AND PART LOCATIONS....	7	CENTRIFUGAL CLUTCH.....	24
DESCRIPTION AND PART FUNCTIONS..	8	TIRES.....	25
RIGHT HAND THROTTLE GRIP.....	8	REPLACING.....	25
ENGINE STOP SWITCH.....	8	STORAGE.....	26
LEFT HAND BRAKE LEVER.....	8	RETURNING TO SERVICE.....	26
CHOKE OPERATION.....	9	WASHING THE MINI BIKE.....	27
FUEL VALVE OPERATION.....	9	TRANSPORTING.....	27
FUEL CAP.....	9	TROUBLE SHOOTING.....	28
STARTER RECOIL CORD.....	9	SPECIFICATIONS.....	29
OIL FILL PLUG.....	9	FRAME AND ENGINE NUMBER	
FUEL AND OIL.....	10	LOCATION.....	30
FUEL.....	10	EMISSION CONTROL SYSTEM	
ENGINE OIL.....	10	WARRANTY.....	31
PRE RIDE INSPECTION.....	11		
RIDING MINI BIKE.....	12		
HELMET, EYE PROTECTION AND			
PROTECTIVE CLOTHING.....	12		
STARTING THE ENGINE.....	13		
STARTING OFF.....	14		
LOAD GUIDELINES.....	15		
MAINTENANCE.....	16		
MAINTENANCE CHART.....	17		
AIR FILTER.....	18		
SPARK PLUG.....	19		
ENGINE OIL.....	20		
CHECKING.....	20		
CHANGING.....	20		
THROTTLE CABLE ADJUSTMENT.....	21		
FUEL HOSE INSPECTION.....	21		
BRAKES.....	22		
BRAKE LEVER ADJUSTMENT.....	22		
BRAKE ADJUSTMENT.....	22		
VALVE CLEARANCE.....	22		



## **COLEMAN POWERSPORTS LIMITED WARRANTY**

**This Warranty is NOT the Emissions Control Warranty**

**Please note this is a general Limited Warranty for this product. It IS NOT an Emissions Control Warranty. Please see the Emissions Control Warranty in this manual for warranties covering Emission components. The Emissions Control Warranty can be found on page 31.**

### **The Warranty**

**Coleman Powersports offers the following warranty to the initial purchaser of this new Coleman Powersports product. The initial purchaser is defined as the first person to purchase a new Coleman Powersports product from an Authorized Retailer.**

**The limited warranty period for this product is 90 days from the date of purchase shown on the original sales receipt.**

### **What is a Defect?**

**The Product is warranted to be free from manufacturing defects in material and workmanship for a period of 90 days from the date of purchase shown on the sales receipt. During this period of time Coleman Powersports will, at its option, either repair, refund purchase amount, or replace any original Coleman Powersports unit/part which is covered by this warranty and is proven to be defective in workmanship or material.**

**To qualify for this warranty the part:**

- 1. Must have been purchase from Coleman Powersports or from an authorized Coleman Powersports Retailer.**
- 2. Must have been used in a manner consistent with the intended use for the vehicle. This warranty does not apply to any vehicle which is used in competition or used in a manner not consistent with the intended use for the vehicle which would also include rental or commercial use.**

### **Who Can Perform Repairs Under this Warranty?**

**Repairs under this warranty should be performed by an authorized Coleman Powersports retailer or comparable servicing dealer.**

### **How to get service under this warranty**

**To get warranty service call Coleman Powersports at 888-405-8725 for the location of your local servicing retailer / dealer. Please do not return the product to the retailer where the product was purchased unless instructed to do so by Coleman Powersports. The retailer of this product does not make any warranty of its own and has no authority to implement this warranty on behalf of Coleman Powersports without the approval of Coleman Powersports. A COPY OF YOUR SALES RECEIPT IS REQUIRED FOR WARRANTY SERVICE.**

### What this Warranty Does Not Cover

This warranty does not cover the following

1. Damage to lack or improper maintenance as describe in this manual.
2. Damage which is caused by normal use and not cause by a defect in materials or workmanship.
3. Use of the product which is not consistent with the intended use as described in the operating instructions.
4. Any expendable maintenance items which needs replacement or service as normal maintenance requires unless these normal maintenance items become defective prior to their normal life due to a material defect or a defect in workmanship.
5. Any product which has been altered or modified in a manner not consistent with the original design of the product or in a manner not approved by Coleman Powersports.
6. Tires
7. Damage or failures due to abuse, neglect, or misuse of the product.

### Limitations of this Warranty

This warranty does not cover and Coleman Powersports disclaims any responsibility for:

1. Loss of time or loss of use of the product.
2. Transportation costs to and from the authorized center.
3. Other loss or damage to other equipment or personal items.

### Length of Implied Warranties

Any implied warranties are limited to the duration set forth in this warranty. Coleman Powersports does not make any claim as to the merchantability or fitness for a particular purpose which would extend longer than the duration of this written warranty.

Check your State Laws as some State Laws do not allow limitations as to the duration of an implied warranty. Some States may also not allow limitation or exclusions based on incidental or consequential damages.

# IMPORTANT LABELS

## LOCATION

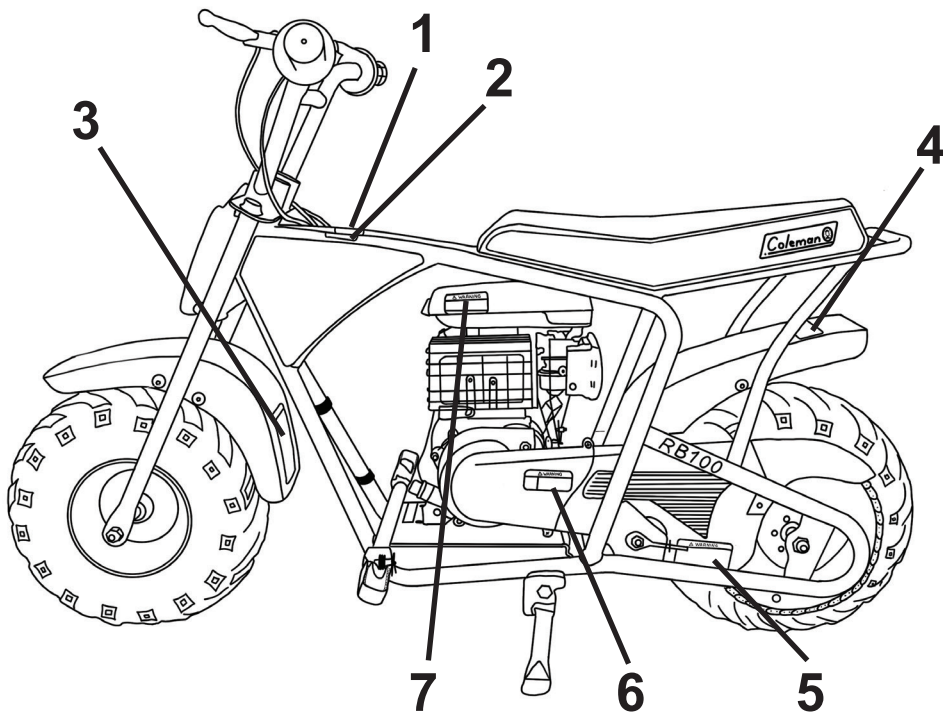



## Warning Labels

**3**  **WARNING**

This Mini Bike can cause serious injury or death if the warnings and instructions in the owner's manual and on warning labels are not followed.

**Never Operate this Mini Bike:**

- at speeds too fast for your skills or the conditions.
- on public roads, a collision can occur with another vehicle.
- carrying a passenger, a passenger can affect balance and control.
- while under the influence of alcohol or drugs
- with long hair or loose clothing unconstrained. Long hair and loose clothing can get caught in moving parts of the mini bike and cause serious injury or death.
- in an unsafe manner by attempting stunts, jumps or wheelies. This could lead to severe injury or death.

**Always:**

- wear a DOT certified helmet, eye protection, gloves, over the ankle boots, long sleeve shirt and long pants.
- avoid paved surfaces, paved surfaces can adversely affect handling and control.
- keep hands and feet away from all moving parts.
- Check the throttle to ensure it works properly and snaps back to idle prior to starting the mini bike.
- be seated before attempting to start the mini bike.
- continually supervise children 13-16

Recommended age for operation is 13 and older

**2**  **WARNING**

Check the following before operating.

1. Engine oil level.
2. Lubricate and adjust drive chain if necessary.
3. Clean and Lubricate clutch.
4. Insure all Guards are in place.

**1**  **WARNING**

THIS VEHICLE IS A RESTRICTED - USE MOTORCYCLE AND IS NOT INTENEDED FOR USE ON PUBLIC HIGHWAYS / VÉHICULE EST UNE MOTOCYCLETTE À USAGE RESTREINT OU UN VÉHICULE TOUT TERRAIN ET QU'IL N'EST PAS DESTINÉ À ÊTRE UTILISÉ SUR LES CHEMINS PUBLICS.

**7**  **WARNING**



**HOT SURFACES**  
Allow to cool before refueling

**6**  **WARNING**



Keep hands and fingers away from chains and sprockets. Make sure guards are securely in place before operation.

**4**

**DO NOT RETURN TO STORE!**  
FOR SERVICE AND REPAIR, PLEASE CALL  
**COLEMAN POWERSPORTS**  
TOLL FREE 888-405-8725

**5**  **WARNING**

Check the tires before operating to insure the proper tire pressure. Improperly inflated tires can lead to loss of control which could result in injury or death.

Cold tire pressure:

Front: 5psi ± .5psi (34.5 ± 3.5kpa)  
Rear: 5psi ± .5psi (34.5 ± 3.5kpa)

Maximum weight capacity is 150 LBS. (68 kg)

## **SAFETY**

**This Mini Bike is recommended for riders 13 and older.**

**Always wear a certified DOT motorcycle type helmet that fits properly, over the ankle boots, eye protection, gloves, long sleeve shirt and long pants while operating this mini bike.**

**Never allow a passenger on this mini bike. This mini bike is designed for one operator and no passengers.**

**Never operate this mini bike on paved surfaces and/or public roads. Pavement may cause the mini bike to become unstable. The tires on the mini bike are for off-road use only.**

**Always go slowly and pay attention to unfamiliar terrain. Be alert to changing terrain conditions when operating the Mini bike.**

**Never operate with long hair or loose clothing unconstrained. Long hair and loose clothing can get caught in moving parts of the mini bike**

**Never take drugs or alcohol before or during operation of this mini bike.**

**Never traverse, climb or go down a hill that is too steep. Avoid hills with loose or slippery terrain.**

**Never attempt wheelies, jumps or any other type of stunts on this mini bike.**

**Always follow the pre-ride inspection procedures and maintenance procedures located in this manual before use.**

**Always go slow on terrain that is not familiar, be alert, an obstacle could come up unexpectedly.**

**Always keep both hands on the handlebars and both feet on the foot pegs, doing so will help the operator be ready for unexpected situations.**

**Do not operate in fast flowing water. Water can affect the braking performance of the mini bike. Check braking performance after exposure to water, it may be necessary to apply the brakes allowing friction to dry out the pads.**

**Always Check the throttle to ensure it works properly and “snaps back” to idle prior to starting the mini bike.**

## DESCRIPTIONS AND PART LOCATIONS

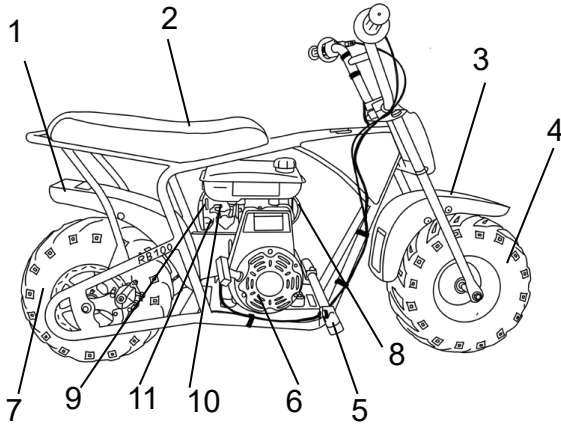

1. Rear Fender
2. Seat
3. Front Fender
4. Front Wheel
5. Foot Pegs
6. Starter Recoil
7. Rear Wheel
8. Fuel Valve
9. Choke Lever
10. Carburetor
11. Air Filter Assembly
12. Kick Stand
13. Fuel Tank and Cap
14. Chain Guard
15. Chain
16. Chain Adjustment
17. Muffler
18. Clutch Cover
19. Front Fork Assembly
20. Left Hand Grip
21. Rear Brake Lever
22. Rear Brake Cable
23. Throttle Cable
24. ON/OFF Switch
25. ON/OFF Switch
26. Throttle Grip

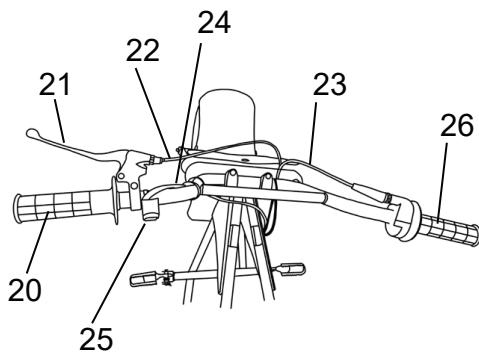
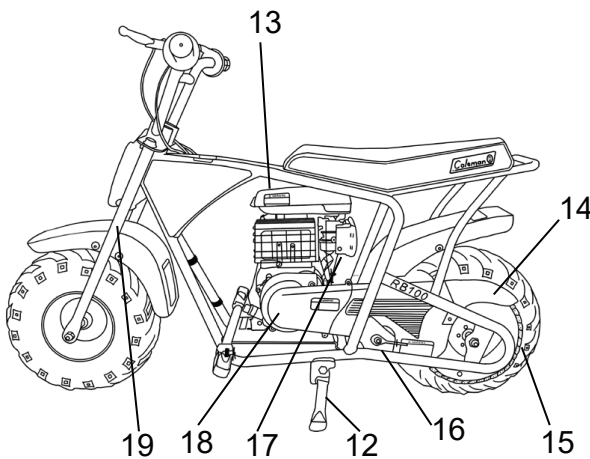



## DESCRIPTION AND PART FUNCTIONS

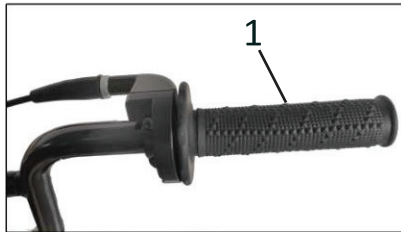

**Right Throttle Grip(1):** The engine speed is regulated by the position of the right throttle grip. Throttle is increased by turning the throttle grip toward the operator. Engine speed is decreased by turning the throttle grip away from the operator.



**Engine Stop Switch (2):** Mini Bike engine can start when the Engine stop switch is placed in the (on) position. Engine will shut off and the engine will not start when the switch is placed in the (off) position.



**Left hand brake lever (3):** The rear brake is applied when the left hand brake lever is pulled toward the hand grip.

## DESCRIPTION AND PART FUNCTIONS

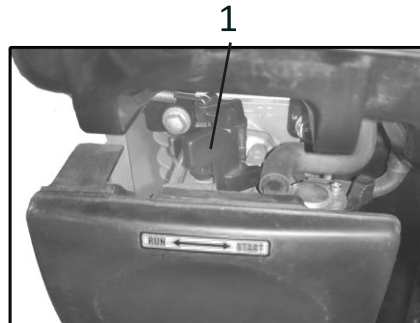

### Choke operation

Choke Lever (1): If the engine is cold, the choke can help start the engine by placing the choke lever to the “ON” (right position. Once engine has warmed up , place choke lever back to the “OFF” (left position.

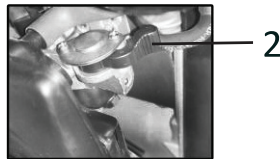

### Fuel Valve operation

Fuel Valve (2): To start the engine and run the mini bike, the fuel valve needs to be placed in the “ON” (vertical position. This allows fuel to flow to the carburetor. When finished riding, and while transporting, place fuel valve in the “OFF” (horizontal position.



### Fuel Cap

#### Fuel Tank Cap

To open the fuel tank cap (3), Turn the cap counter clockwise to remove. To re-install the cap, turn the cap clockwise until snug.

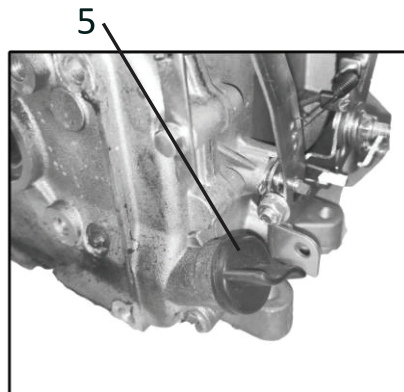

### Starter Recoil Cord

#### Starter Recoil Cord (4)

To start the engine, place the on/off switch locate on the handlebars to the “ON” position and pull the Starter Recoil Cord

### Oil Fill plug

#### Oil Fill Plug (5)

To check or add oil, open the oil fill plug/dipstick by turning counter clockwise. To tighten, turn clock-wise.

## FUEL

Never use leaded gasoline in this product. It could affect the engine's emissions and damage the engine. Mini Bike requires clean unleaded regular gasoline with a minimum octane rating of 86 or higher.

### Gasoline/ Ethanol blends

A blend of unleaded gasoline with Ethanol, also known as GASOHOL, at or below 10% (E10 ) can be used in your Mini Bike. Ethanol greater than 10% can damage your engine and will void your warranty.

### Gasoline/Methanol Blends

A blend of gasoline with Methanol of 5% or less can be used in your Mini Bike. Do not use gasoline, under any circumstances, containing more than 5% Methanol, doing so will damage your engine and will void the warranty.

## Fuel Filling

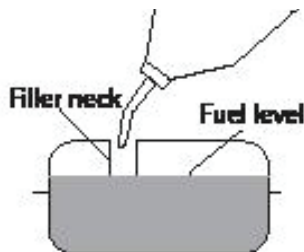

## ⚠ WARNING

Over filling the fuel tank can cause the fuel to expand which can cause overflow due to the heat from the engine or sun. Spilled fuel can catch fire.

Never fill the fuel tank above the bottom of the filler neck.

## FUEL AND OIL

## ⚠ WARNING

Fuel and fuel vapor are highly flammable and toxic. You can be burned or poisoned while refueling.

Before refueling make sure to follow the procedures listed:

- 1 Shut off engine, Make sure there are no flames, sparks or heat sources close by.
- 2 Refuel only outdoors in a well ventilated area.
- 3 Do not smoke while refueling.
- 4 Wipe up any spills immediately.
- 5 Avoid breathing any fuel vapors.
- 6 Keep children and pets away.

## ENGINE OIL

The recommended oil for this Mini Bike is SAE15W-40 motor oil, if this oil is not available, any of the oils on the chart below will work. Note the temperature requirements for each of the oils.

Quantity of oil - .63qt. (.6L).

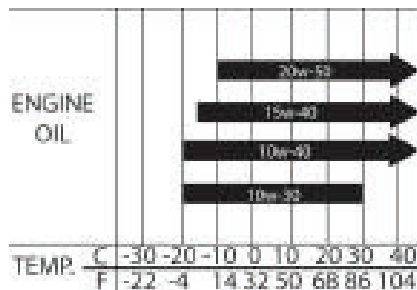



## PRE-RIDE INSPECTION

Inspecting and checking the condition of the Mini Bike before each ride is important. Following the pre-ride check list will help insure the you do not have mechanical problems which could result in injury or becoming stranded. Make sure the Mini Bike is in good operating condition before each ride.

**⚠ WARNING**

Failing to inspect and maintain your Mini Bike could be hazardous.

Not following the pre-ride inspection procedures could result in losing control of the Mini Bike resulting in an accident or damage to the Mini Bike

Always perform a Pre-ride inspection before each ride.

**⚠ WARNING**

Performing maintenance and checks while the engine is running could be hazardous.

You could be severely injured by moving parts or hot surfaces.

Never perform maintenance or check procedures while the engine is running with the exception of checking the engine stop switch or throttle.

WHAT TO CHECK	CHECK FOR
Steering	<ul style="list-style-type: none"> <li>• Smoothness</li> <li>• No restriction of movement</li> </ul>
Brakes	<ul style="list-style-type: none"> <li>• Brake shoe wear.</li> <li>• Proper brake lever play</li> </ul>
Tires	<ul style="list-style-type: none"> <li>• Proper tire pressure</li> <li>• Proper tread depth</li> <li>• Rubber has no cracks</li> </ul>
Fuel Tank	<ul style="list-style-type: none"> <li>• Enough fuel for the ride</li> <li>• Fuel cap secure</li> <li>• Hoses have no signs of cracks or leaks</li> </ul>
Throttle grip	<ul style="list-style-type: none"> <li>• Throttle grip snaps back to idle when released</li> <li>• Operates freely</li> <li>• Has correct free play</li> </ul>
Engine Stop Switch	<ul style="list-style-type: none"> <li>• Switch shuts off engine when activated.</li> </ul>
Engine Oil	<ul style="list-style-type: none"> <li>• Correct oil level</li> </ul>
Drive Chain	<ul style="list-style-type: none"> <li>• Proper tension</li> <li>• Lubricated</li> <li>• No excessive wear or damage</li> </ul>
General Condition	<ul style="list-style-type: none"> <li>• All nuts and bolts tight</li> <li>• No rattles from engine or frame while running</li> </ul>

## RIDING THE MINI BIKE

### HELMET, EYE PROTECTION,

#### PROTECTIVE CLOTHING

Always wear a DOT or SNELL certified motorcycle helmet (1). A helmet helps protect against serious head injuries in the event of an accident. A helmet is the most important safety gear item you can wear. Consult with a motorcycle dealer for the correct size and type of motorcycle helmet that is right for you.

Always wear eye protection when riding a Mini Bike such as a face shield or goggles (2). While riding a Mini Bike you can be hit in the eyes by any of the following: dust, branches, rocks, debris from other riders, bugs, etc. Good eye protection as well as a helmet and protective riding gear should be mandatory when riding a Mini Bike.

Wear protective clothing: Long sleeve shirt (3), Gloves (4), Long pants (5), over the ankle boots (6). Riding a Mini Bike exposes the rider to many hazards, wearing protective clothing can help protect the rider from injury.



### **⚠ WARNING**

Riding the Mini Bike without a helmet, eye protection, and protective clothing can be hazardous

Riding a Mini Bike without a helmet increases the chance of severe head injury or death in the event of an accident.

Riding a Mini Bike without eye protection such as a face shield or goggles could result in severe injury in the event of an accident.

Riding a Mini Bike without protective clothing; over the ankle boots, long pants, gloves, long sleeve shirt could result in severe injury in the event of an accident.

Always wear a Helmet, eye protection, long pants, long sleeve shirt, over the ankle boots and gloves when riding the Mini Bike.

# RIDING THE MINI BIKE

## STARTING ENGINE

To start the engine

1. Place the fuel valve (1) in the "ON" (vertical) position.
2. If engine is cold, place the choke lever (2) in the "ON" (right) position.
3. Place the ON/OFF switch (3), located on the handlebars, in the  (on) position.
4. Pull the starter recoil cord (4) to start the engine.
5. Once engine has warmed up for a few minutes, place the choke lever (2) back to the "OFF" (left) position.

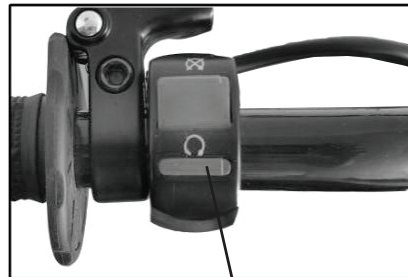
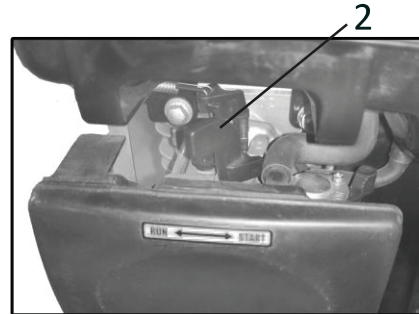
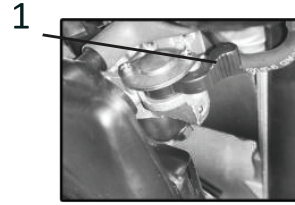

3

## **⚠ WARNING**

Starting or running the Mini Bike in an enclosed area such as a garage or shed where there is no ventilation is hazardous.

Inhaling exhaust fumes from the Mini Bike can cause severe injury or death

Never start or run the Mini Bike in an enclosed environment where there is no ventilation. Always start and run outdoors.



4

# RIDING THE MINI BIKE

## STARTING OFF

1. Start and warm up the engine according to the instructions in this manual.
2. Place the side kick stand in the up position.
3. Apply the throttle gradually to start riding. Practice riding Mini Bike on a flat dirt surface that has plenty of room for turning.

### **⚠ WARNING**

Turning the throttle grip to full throttle when starting off could be hazardous.

The Mini Bike could lurch forward causing the front wheels to leave the ground causing loss of control.

Always open the throttle gradually when starting off from a stopped position.

### **⚠ WARNING**

Operating this Mini Bike at excessive speeds could be hazardous.

Riding at excessive speeds increases your chances of losing control of the Mini Bike, which could result in severe injury or death.

Always go at a speed that is proper for the terrain, visibility, operating conditions, operator skill, and operator experience. Always know the terrain before riding.

### **⚠ WARNING**

Removing hands from the handlebars and/or feet from the footrest while operating the Mini Bike could be hazardous.

Removing both or one hand from the handlebars and/or feet from the footrests could result in loss of control of the Mini Bike resulting in severe injury or death.

Always ride with both hands on the handle bars and both feet on the footrests while operating the Mini Bike.

### **⚠ WARNING**

Braking while turning could be hazardous.

Braking while turning could cause the Mini Bike to slide out of control which could result in severe injury or death.

Before making a turn, slow down and release the brake.

# RIDING THE MINI BIKE

## Load Guidelines

Load guidelines including accessories:

Never exceed the maximum load capability of the Mini Bike. This includes the weight of the rider and any cargo. This Mini Bike is rated at 150lbs. (68kg).

Do not add any accessory or cargo to the handlebars that could impede vision or make the Mini Bike harder to steer.

Make sure accessories do not get in the way of any controls of the Mini Bike.

## After Market parts

After market parts and accessories may be available from other manufactures. Coleman Powersports cannot confirm the quality, safety or suitability of accessories available. When purchasing an accessory, use caution, the handling of the Mini Bike could become affected. Some accessories may make the Mini Bike unsafe to ride. If you have a question about a modification or accessory, contact your dealer or call Coleman Powersports.

## WARNING

Riding this Mini Bike with modifications or adding accessories could be hazardous.

Modifications to the Mini Bike, including adding accessories, could adversely affect the handling of the Mini Bike causing an accident which could result in severe injury or death.

Never Modify this Mini Bike in any way, including adding accessories, unless the modification is a genuine certified modification or accessory approved by the manufacture. Never modify the Mini Bike with improper installation. Make sure to follow all instructions recommended in the certified modification. Use only genuine parts. For questions, contact your dealer.

# MAINTENANCE

For maintenance, your mini bike may be maintained by an authorized Coleman Powersports service dealer or a repair shop of your choosing.

Following the proper maintenance procedures and time table for maintenance listed in this manual is important for the safety of the rider and the life span of the Mini Bike. When riding in harsh conditions, such as water, mud and dust, the maintenance procedures should be performed more often.

## **⚠ WARNING**

Failing to perform the recommended maintenance on this Mini Bike could be hazardous.

Failing to perform proper maintenance on this Mini Bike could result in an accident

Always perform the recommended maintenance for the Mini Bike as noted in this manual.

## **⚠ WARNING**

Performing maintenance and inspection while the engine is running could be hazardous.

Performing maintenance and inspections while the engine is running could result in getting body parts or clothing caught in moving parts, or could result in touching hot items which could result in severe injury.

Shut off engine when performing maintenance and inspection checks, with the exception of checking the engine stop switch and throttle.

## **CAUTION**

Failing to perform recommended maintenance on this Mini Bike could damage the Mini Bike engine and components

Always perform the recommended maintenance on this Mini Bike as listed in this manual.

Maintenance will need to be performed more often if ridden in wet, muddy or dusty conditions.

## **CAUTION**

Failing to use compatible parts with the original replacement parts could damage Mini Bike

Using parts that are of low quality could result in Mini Bike break-downs and reduce the useful life of the Mini Bike.

Never use parts that are not compatible with the original parts..

## MAINTENANCE CHART

In order to maintain good performance, check and maintain the motorcycle at the intervals listed in the Maintenance chart.

The capital letters in the following chart represent:

I: Inspect, including troubleshooting, cleaning, adding lubricating oil, adding oil, repairing and replacement.

A: Adjustment C: Cleaning R: Replacement L: lubricating

Maintenance Period	Time (hrs)													
	10	30	60	90	120	150	180	210	240	270	300	330	360	Before each ride
Lubricating oil	R			R			R			R			R	I
Air filter	Begin from 100hrs, clean every 100hrs, replace if necessary													
Spark plug	Begin from 100hrs, clean every 100hrs, replace if necessary													
Valve clearance	A			A			A			A			A	
Fuel strainer				R			R			R			R	
Brake system	I	I	I	I	I	I	I	I	I	I	I	I	I	I
Drive Chain	I/L			I/L			I/L			I/L			I/L	I
Fasteners	I/A			I/A			I/A			I/A			I/A	
<ul style="list-style-type: none"> <li>• While the hours may exceed the maximum data in the chart, please maintain the maintenance procedures at the hour intervals listed.</li> <li>• If riding in dusty or wet conditions, provide maintenance more frequently.</li> </ul>														



## MAINTENANCE

### Air Filter

The air cleaner element needs to be cleaned or replaced periodically (see chart for cleaning/replace-ment intervals. The air filter element will need to be cleaned more often if Mini Bike is ridden in muddy, wet, or dusty conditions. A clean air filter will help the Mini Bike run at peak performance allowing better gas mileage, more power and will protect the engine from the damaging effects of dirt entering the engine.

### CAUTION

Clean air filter frequently if Mini Bike is driven in wet, muddy or dusty conditions.

Driving in the above conditions without cleaning frequently can plug up the air filter which can cause poor gas mileage, low power and cause damage to the engine.

### Air filter removal, inspection and cleaning instructions

1. Locate the air filter assembly (1)
2. Remove the Air filter assembly cover by removing the air filter cover knobs (2).
3. Remove the foam element (3).
4. Clean foam element with mild soap and water. Rinse and squeeze out excess water and allow to dry .

Note: If foam element (3) is damaged, replace.

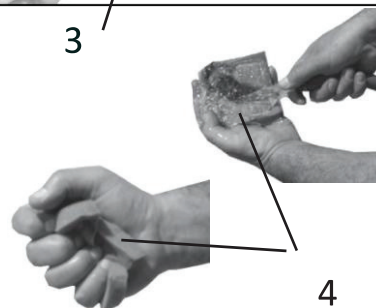
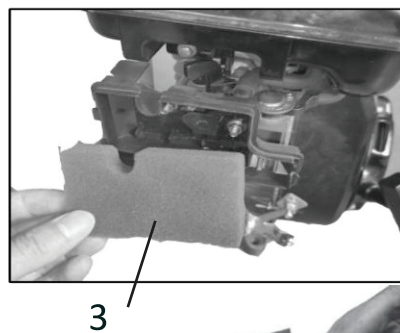
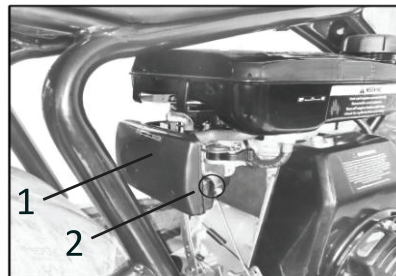

# MAINTENANCE

## Spark Plug

This Mini Bike comes equipped with a CHDY-E6TC spark plug.

To inspect the spark plug, remove the air filter cover and element to gain access. Remove spark plug cap (1) then remove the spark plug from the engine with the spark plug tool provided.

Inspect the plug for carbon deposits and clean if necessary. If plug shows excessive carbon, replace the plug.

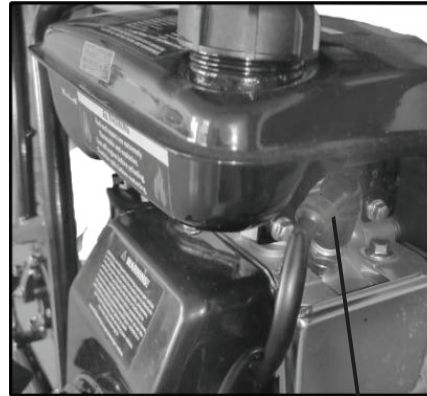

1

### CAUTION

Dirt can damage the engine if it enters the spark plug hole.

Make sure the spark plug hole is covered after removing plug.

Use a thickness feeler to inspect the spark plug gap (2). The spark plug gap should be 0.6 - 0.8mm (0.024 - 0.032 in.)

Re-install the inspected plug or new plug until finger tight. Finish tightening plug with a wrench. If the plug is a new plug, tighten approximately 1/2 turn more with the wrench. If plug is an old plug, tighten approximately 1/8 turn more with a wrench.

CHDY-E6TC

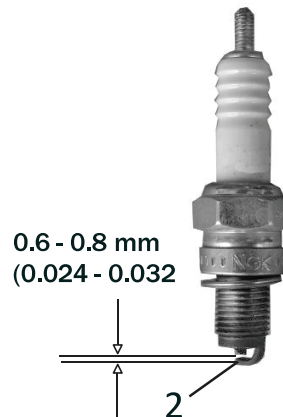

# MAINTENANCE

## Engine Oil

The proper amount and grade of engine oil will have a great impact on the life of the engine. Checking the oil daily and changing the oil as listed in the maintenance schedule is the most important maintenance procedure for the engine.

### Checking the engine oil

1. Make sure the Mini Bike is on level ground.
2. Check engine oil level by removing the oil fill plug/dipstick (1) located on bottom front left front side of the engine.
3. If engine oil is low, add oil until oil is at edge of fill hole (2). Use the correct grade of oil as listed in this manual. Do not over or under fill engine with oil, this could damage the engine.

### Changing the engine oil

1. Make sure engine is warm before attempting to drain the oil. A warm engine will help the oil drain quicker.
2. Remove the oil fill plug (1)
3. Remove the drain bolt (3) located on the bottom of the engine.
4. Allow the oil to drain in an appropriate container. Note: Dispose of oil at an oil recycle center.
5. Install the drain plug and fill with the appropriate type of oil as listed in this manual. This mini bike takes .37qt. (.35L) of engine oil.
6. Re-install fill cap, Start engine and allow to run for a few minutes, Re-check oil level and fill accordingly.

## ⚠ WARNING

New and used oil can be hazardous

Children and pets can be harmed by swallowing new or used oil. Continuous contact with used engine oil has been found to cause skin cancer in laboratory animals

Always keep new or used oil away from children and pets.

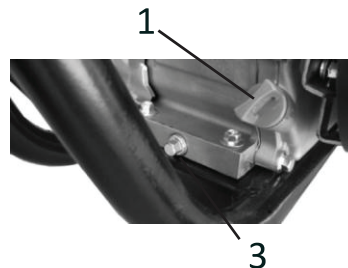
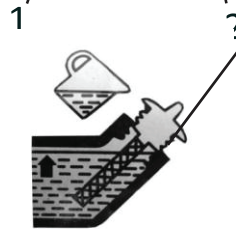
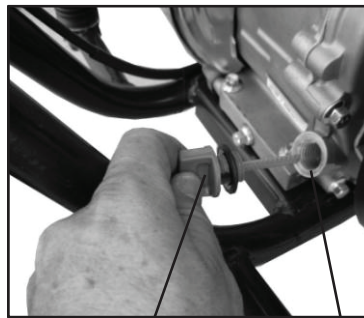

# MAINTENANCE

## Throttle Cable adjustment

It is important that the throttle grip have a certain amount of free play so the throttle does not rise when the handlebars are turned from left to right.

The hand grip throttle free play (2) should be .078 - .24 in (2-6 mm) To adjust free play

1. Loosen jam nut (3)
2. Turn adjusting nut (4) to proper setting
3. Once throttle grip is at the proper free play, re-tighten the jam nut (3).

**NOTE:** After any adjustment, make sure throttle snaps back to idle when released.

## Fuel Hose Inspection

Inspect the fuel hose for any cracks or leaks and make sure all clamps are in place. Replace the fuel hose if any defects are found.

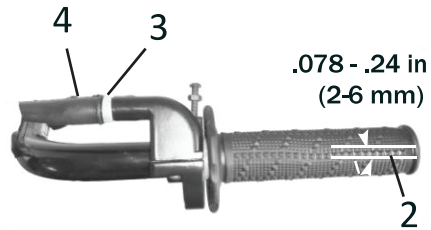

## **⚠ WARNING**

Inadequate throttle play can be hazardous

The engine speed could rise when the handlebars are turned if there is not enough throttle play. This could result in loss of control.

Always check throttle play before each ride. Turn handlebars from side to side making sure throttle does not increase when doing so.

# MAINTENANCE

The front left brake lever (1) should have 2.0 - 4.0mm (0.08 - 0.16) of free play.

To adjust brake lever free play:

1. Loosen the Jam nut (2) on the brake cable.
2. Turn the adjuster nut (3) until the correct amount of free-play is achieved.

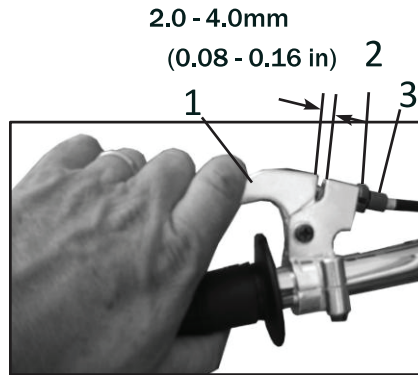

## Brake Adjustment

The brake adjustment (4) is located on the rear brake caliper assembly.

To adjust brakes, loosen nut (4). Increase or decrease the tension of the brake cable by pulling cable tighter or by allowing more slack.

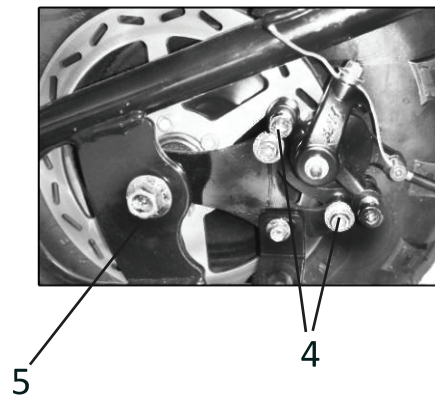

## Valve Clearance:

Adjusting the valves should be done by an authorized service center. Proper valve gap will help Mini Bike run at peak performance. Follow the valve gap adjustment intervals listed in the maintenance chart.

### Proper Valve Clearance

Intake: 0.1 - 0.15 mm  
Exhaust: 0.15 - 0.2 mm

# MAINTENANCE

## Chain

### Chain and Sprocket Inspection

Inspect the drive chain for wear, rust, bound links, proper lubrication and proper tension.

If the drive chain has a problem correct or replace. Contact a service center for chain replacement.

A worn drive chain could also mean the sprockets may be worn.

Look for the following on the sprockets (1): Worn teeth, broken or damaged teeth, Loose sprocket mounting nuts.

If the sprocket shows signs of wear, contact a service center for replacement.

### Chain tension

Check the slack tension of the chain, the chain (1) slack tension should be 1/2 - 3/4 in. (15-20mm)

### Chain tension (slack) adjustment

1. Loosen bolt on chain tensioner (2).
  2. Move Tensioner back to tighten chain or forward to loosen chain.
  3. If chain needs more tightening after adjustment, loosen the 4 bolts on the bottom of the engine plate and move engine forward .
- Note: Make sure chain is in line with sprockets after adjustment
4. Re-check chain tension.

## Chain Lubrication

Lubricating the chain before each ride will help to ensure maximum life of the chain and sprockets.

### Instructions for cleaning and chain lubrication:

1. Clean chain with a chain cleaner.
2. Lubricate chain with chain lube.

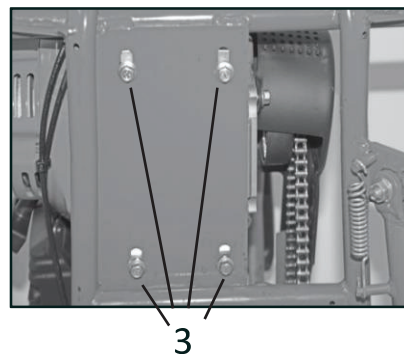
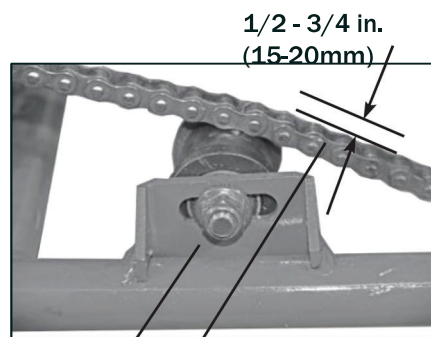
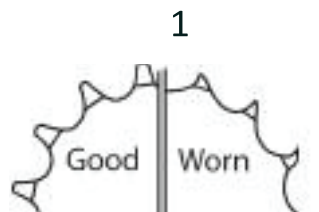

## MAINTENANCE

### Centrifugal Clutch Cleaning and lubrication

To help ensure the maximum life out of the Centrifugal clutch. It is important to clean and lubricate the clutch after every 5 hours of operation. To Clean and lubricate, follow the instructions below. Make sure engine is not running and that the engine and clutch has had time to cool.

2. Remove clutch cover (1).
3. Wipe off Centrifugal clutch (2) with a clean rag.
4. Lubricate Centrifugal clutch (2) using the same type of motor oil that is used in the engine. Place a few drops of motor oil on the drive shaft (3) where the clutch is attached. Do not oil any other portion of the clutch. **DO NOT PLACE ANY OIL IN THE LARGE HOLES IN THE CLUTCH. THE HOLES ARE FOR AIRCIRCULATION ONLY. DO NOT OIL THE INSIDE OF THE CLUTCH.**
5. RE-INSTALL THE CLUTCH COVER BEFORE STARTING OR OPERATING THE MINI BIKE.

Shut off engine and allow to cool before performing maintenance and inspection on the centrifugal clutch.

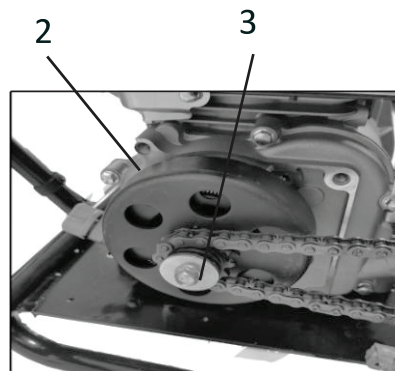
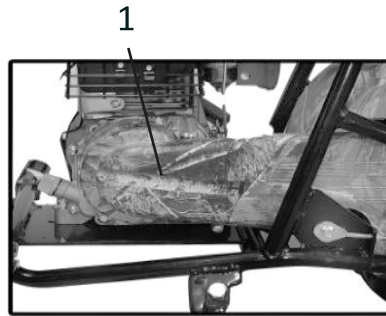

### **WARNING**

Performing maintenance and inspection on the centrifugal clutch while the engine is running could be hazardous.

Performing maintenance and inspections on the centrifugal clutch while the engine is running could result in getting body parts or clothing caught in moving parts, or could result in touching hot items which could result in severe injury.

### **WARNING**

Operating the mini bike without the clutch cover in place could be Hazardous.

Operating the mini bike without the clutch cover could result in getting body parts or loose clothing caught in moving parts which could result in severe injury.

Never Start or operate the mini bike without the clutch cover in place.



# MAINTENANCE

## Tires

Inspect tires before each ride, this should include the following:

1. Inspect for cracks or leaks
2. Inspect tread depth. If tread depth is below 4mm (.16 in.) replace the tire.
3. Check tire pressure. Incorrect tire pressure can affect the handling, rider comfort, steering, tire life and traction. Always check the tire pressure before each ride.

### Tire pressure

Front tires: 5psi (34 kpa)

Rear tires: 5psi (34kpa)

### Tire size:

Front tires: AT145/70-6

Rear Tires: AT145/70-6

## Replacing tires

Always replace tires with type and size listed in this manual.

Always use the correct tools when replacing tires. The bead and sometimes the rim can be damaged by using the wrong type of tools. It is usually best to have tires replaced by an authorized service center.

Service centers have the correct equipment and expertise to change tires without causing damage.

Punctures to tires can usually be repaired by using plug type patches. Plug type patches cannot repair tires that have been cut. If the tire has been cut or has a puncture in a location or size that cannot be repaired, replace the tire.

Be prepared for flat tires, always carry a plug type patch kit and air pump with you.



Minimum tread  
4mm (.16 in.)



## ⚠ WARNING

Operating this Mini Bike with worn tires could be hazardous

Operating this Mini Bike with worn tires will reduce traction which could result in an accident.

Never operate this Mini Bike with tires that have a tread depth of less than 4mm (0.16 in.)

## ⚠ WARNING

Operating this Mini Bike with improper tire sizes or pressure could be hazardous

Operating this Mini Bike with improper tire sizes or pressure could result in loss of control of the Mini Bike which could result in an accident.

Never operate this Mini Bike with improper tire sizes or pressure.

## Storage

If the Mini Bike is left unused for an extended period of time proper storage maintenance is required.

1. Wash Mini Bike thoroughly, then wax painted parts with a non abrasive auto wax. Coat vinyl seat and rubber parts with a vinyl/rubber protectant. Note: Keep water away from air intake and muffler outlet while washing to avoid water from entering the engine and/or components.

2. Drain carburetor by placing fuel valve (1) to the off (horizontal) position and opening the drain screw (2). Allow all fuel to drain from the carburetor. Once fuel is drained, re-tighten drain screw (2). Note: Make sure to drain fuel in a proper storage container.

3. Fill fuel tank to full with gasoline mixed with fuel stabilizer as recommended by the fuel stabilizer manufacture. Note: Fuel stabilizer can be purchased at most motorcycle shops and auto parts stores.

4. Remove spark plug and pour 1 tablespoon of motor oil in the spark plug hole. Re-install spark plug.

5. Place the starter button to the off position and pull the start recoil cord a few times. This is to coat the inside cylinder head with oil.

6. Fill tires with correct air pressure.

7. If possible, store Mini Bike in a shed or garage with a cover to protect from dust, dirt and humidity. If the Mini Bike must be stored outdoors, cover completely with a good waterproof cover.

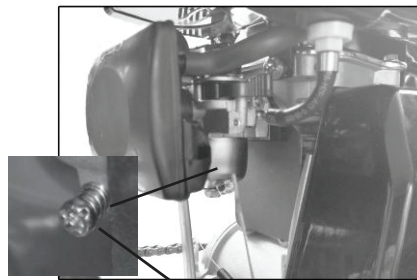
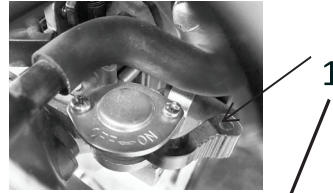

2

## Returning to service

1. Wash Mini Bike thoroughly. Note: Keep water away from air intake and muffler outlet while washing to avoid water from entering the engine and/or components.

2. Drain engine oil and replace with fresh clean oil as listed in this manual.

3. Review this owner's manual and follow the pre-ride inspection procedures.

4. Start engine by following the starting procedures in this manual.

## Washing the Mini Bike

1. Wash mud and dirt off Mini Bike with low pressure water from a hose. Do not use high pressure nozzles, this could allow water to enter the engine causing damage.

2. Wash Mini Bike using a mild detergent or car soap using a sponge, soft rag or brush. Do not use any cleaning materials that could scratch the surfaces.

Note: Be careful not to allow water to enter the muffler outlet, air filter intake, brake cable, throttle cable or switches.

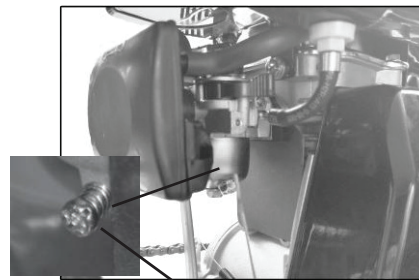
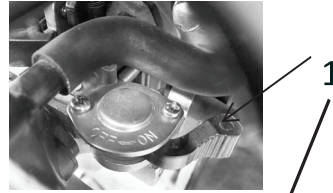

2

## Transporting

1. Make sure fuel valve (1) is turned to the OFF (Horizontal) position.

2. Drain carburetor by turning fuel valve (1) to the off position and opening the drain screw (2). Allow all fuel to drain from the carburetor. Once fuel is drained, re-tighten drain screw (2).

Note: Make sure to drain fuel in a proper storage container.

3. Transport the Mini Bike with the Mini Bike in the upright position (3) tied down securely.

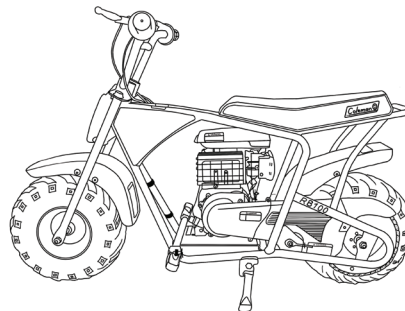

3

## TROUBLESHOOTING

Trouble	Possible Cause	Solution
<b>Engine will not start</b>	<ul style="list-style-type: none"> <li>• Low fuel</li> <li>• Stale or contaminated fuel.</li>   <li>• Fuel valve is in the “OFF” position</li> <li>• Loose spark plug</li> <li>• Spark plug fouled or defective.</li> <li>• Spark plug gap is incorrect</li> <li>• Spark plug cap is not attached</li> <li>• Choke is not in the “ON” (left) position for starting a cold engine.</li> <li>• Problem with the electrical system</li> <li>• Air filter dirty</li>   <li>• Valves not adjusted properly</li> </ul>	<ul style="list-style-type: none"> <li>• Fill with fresh fuel</li> <li>• Have a service center flush and fill with fresh fuel.</li> <li>• Place fuel valve in the “ON” position.</li> <li>• Tighten spark plug</li> <li>• Clean or replace plug.</li>   <li>• Gap the plug</li> <li>• Attach spark plug cap</li>   <li>• Place choke in the “ON” (left) position</li> <li>• Take to a service center for repair</li> <li>• Clean or replace air filter</li> <li>• Take to a service center for repair</li> </ul>
<b>Engine stalls or runs erratically</b>	<ul style="list-style-type: none"> <li>• Low fuel</li> <li>• Stale or contaminated fuel</li>   <li>• Choke is left in the “ON” (left) position</li> <li>• Spark plug is fouled or defective</li> <li>• Spark plug gap is incorrect</li> <li>• Spark plug cap is loose</li>   <li>• Carburetor is clogged or has water in it</li> <li>• Idle is not adjusted properly</li>   <li>• Problem with the electrical system</li> <li>• Air filter dirty</li>   <li>• Valves not adjusted properly</li> </ul>	<ul style="list-style-type: none"> <li>• Fill with fresh fuel</li> <li>• Have a service center flush and fill with fresh fuel.</li> <li>• Place the Choke in the “OFF” (right) position.</li> <li>• Clean or replace plug</li>   <li>• Gap the plug</li> <li>• Secure the spark plug cap</li> <li>• Take to a service center</li> <li>• Take to a service center</li> <li>• Take to a service center for repair</li> <li>• Clean or replace air filter</li> <li>• Take to a service center for repair</li> </ul>



# FRAME AND ENGINE NUMBER LOCATION

The Vehicle identification number and the engine number are needed when calling for parts, service center help or when registering your Mini Bike. Locate the numbers and list the numbers below for reference.

The 17 digit Vehicle Identification Number (VIN) is located on the vertical tube on the neck of the mini bike

Vehicle Identification Number

--	--	--	--	--	--	--	--	--	--	--	--	--	--	--	--	--

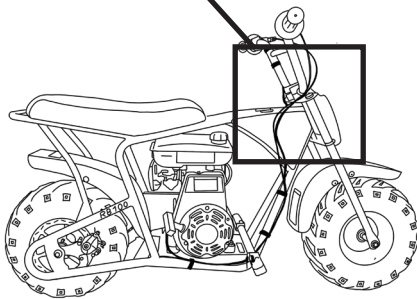
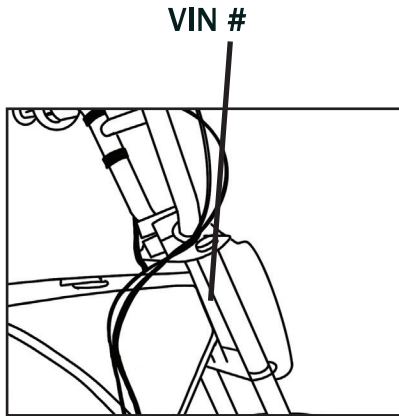

The engine number is located on the bottom front portion of the Mini Bike Engine.

Engine Number

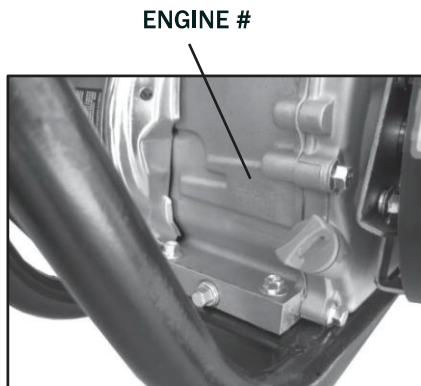
## EMISSION CONTROL SYSTEM WARRANTY

Below is the emission control system warranty printed in the owner's manual, a copy of the owner's manual is available upon your request.

## YOUR WARRANTY RIGHTS AND OBLIGATIONS

The California Air Resources Board, the U.S. Environmental Protection Agency, and Tao Motor Inc. (hereinafter "Tao Motor") are pleased to explain the emission control system warranty on your off-road vehicle. New vehicles must be designed, built and equipped to meet U.S. EPA Federal and California emission standards over the full useful life of 10000km or 60 months, whichever comes first.

Tao Motor must warrant the emission control system on your vehicle for 5,000 km or for 30 months, whichever comes first, provided that there has been no abuse, neglect or improper maintenance of your vehicle.

Your emission control system may include parts such as the carburetor or fuel injection system, the ignition system, catalytic converter and engine computer, if it is equipped. Also included may be hoses, belts, connectors and other emission-related assemblies.

Where a warrantable condition exists, Tao Motor will repair your vehicle at no cost to you, including diagnosis, parts and labor.

If an emission-related part on your vehicle is defective, the part will be repaired or replaced by Tao Motor. This is your emission control system defects warranty.

**NOTICE!** Use of any Tao Motor vehicle in any type of competitive event completely and absolutely voids this and all other warranties offered by Tao Motor.

## OWNER'S WARRANTY RESPONSIBILITIES

As the vehicle owner, you are responsible for the performance of the required maintenance listed in your owner's manual. Tao Motor recommends that you retain all receipts covering maintenance on your vehicle, but Tao Motor cannot deny warranty solely for the lack of receipts or for your failure to ensure the performance of all scheduled maintenance.

You are responsible for presenting your vehicle to the Tao Motor's dealer as soon as a problem exists. The warranty repairs should be completed in a reasonable amount of time, not to exceed 30 days.

As the vehicle owner, you should be aware that Tao Motor may deny your warranty coverage if your vehicle or a part has failed due to abuse, neglect, improper maintenance or unapproved modifications.



If you use your vehicle in any type of sanctioned competitive event, this warranty is immediately and completely void.

If you have any questions regarding your warranty rights and responsibilities, you should contact Tao Motor Inc., 2201 Luna Road, Carrollton, TX 75006, TEL: 972-512-8866 or (for California registered highway vehicles only) the California Air Resources Board at P.O. Box 8001, 9528 Telstar Avenue, El Monte, CA 91731-8001.

Tao Motor warrants that each new 2017 and later Tao Motor's ATV:

A. Is designed, built and equipped so as to conform at the time of initial retail purchase with all applicable regulations of the United States Environmental Protection Agency, and the California Air Resources Board; and

B. Is free from defects in material and workmanship which cause such vehicle to fail to conform to applicable regulations of the United States Environmental Protection Agency or the California Air Resources Board for the periods specified above.

I. Coverage. Warranty defects shall be remedied during customary business hours at any authorized Tao Motor's dealer located within the United States of America in compliance with the Clean Air Act and applicable regulations of the United States Environmental Protection Agency and the California Air Resources Board. Any part or parts replaced under this warranty shall become the property of Tao Motor.

II. Limitations This Emission Control System Warranty shall not cover any of the following:

A. Repair or replacement as a result of:

- (1) Accident
- (2) Misuse
- (3) Repairs improperly performed or replacements improperly installed
- (4) Use of replacement parts or accessories not conforming to Tao Motor's specifications which adversely affect performance and/or
- (5) Use in competitive racing or related events.

B. Inspections, replacement of parts and other services and adjustments required for required maintenance.

C. Any vehicle equipped with an odometer or hour meter on which the odometer mileage or hour meter reading has been changed so that actual mileage cannot be readily determined.

**III. Limited Liability**

A. The liability of Tao Motor under this emission control system warranty is limited solely to the remedying of defects in material or workmanship by an authorized Tao Motor's dealer at its place of business during customary business hours. This warranty does not cover inconvenience or loss of use of the vehicle or transportation of the vehicle to or from the Tao Motor's dealer. Tao Motor shall not be liable for any other expenses, loss or damage, whether direct, incidental, consequential or exemplary arising in connection with the sale or use of or inability to use the vehicle for any purpose. Some states do not allow the exclusion or limitation of any incidental or consequential damages, so the above limitations may not apply to you.

B. No express emission control system warranty is given by us except as specifically set forth herein. Any emission control system warranty implied by law, including any warranty of merchantability or fitness for a particular purpose, is limited to the express emission control system warranty terms stated in this warranty. The foregoing statements of warranty are exclusive and in line of all other remedies. Some states do not allow limitations on how long an implied warranty lasts so the above limitations may not apply to you.

C. No dealer is authorized to modify this Tao Motor Limited Emission Control System Warranty.

**IV. Legal Rights.**

A. This warranty gives you specific legal rights, and you may also have other rights which vary from state to state.

B. This emission control system warranty is in addition to the standard limited warranty for all vehicles.

**V. Additional Information.**

Any replacement part that is equivalent in performance and durability may be used in the performance of any maintenance or repairs. However, Tao Motor is not liable for these parts. The owner is responsible for the performance of all required maintenance. Such maintenance may be performed at a service establishment or by any individual. The warranty period begins on the date the motorcycle is delivered to the retail customer/owner.

Tao Motor Inc.  
2201 Luna Road, Carrollton, TX 75006 U.S.A TEL:  
972-512-8866 FAX: 214 635 3985





# COLEMAN POWERSPORTS

(888) 405-8725

1775 E. UNIVERSITY DR., TEMPE, AZ 85281

[www.colemanpowersportsusa.com](http://www.colemanpowersportsusa.com)

