

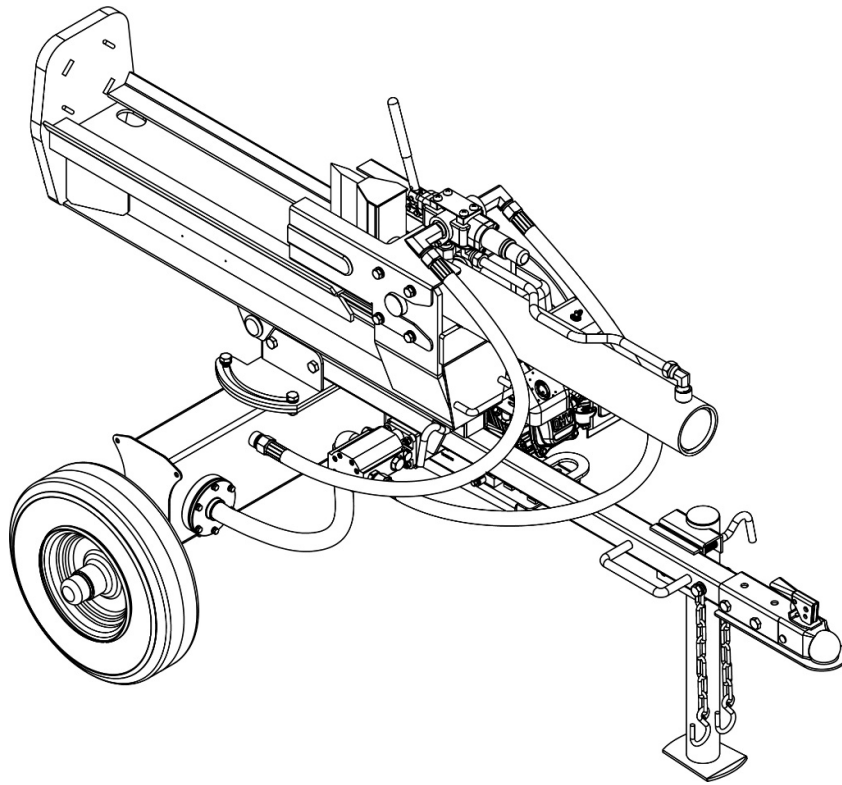

# 20 TON HALF BEAM LOG SPLITTER



**SKU# 2287345**

**Owner's Manual**

## **ASSEMBLY & OPERATING INSTRUCTIONS**



This safety alert symbol identifies important safety messages in this manual. Failure to do so could result in serious injury or death.

# Table of Contents

Important Safety Information.....	3-6
Intended Use.....	3
Personal Protective Equipment.....	3
Safety Decals.....	3-4
General Safety.....	5
Work Area.....	5
Preparation of the Log.....	5
Operation of the Log Splitter .....	5
General Repair.....	5
Maintenance Safety.....	6
Fire Prevention.....	6
Towing Safety.....	6
Assembly Instructions.....	7-12
Controls and Features Identification.....	13
Operating Instructions.....	14-16
Engine Oil Recommendations.....	14
Starting Instructions.....	14
Operation .....	14-15
Towing.....	15
Maintenance.....	15
Splitter Positions.....	16
Troubleshooting.....	17
Specifications.....	18
Drawing & Parts List.....	19-21
Limited Warranty.....	22



## IMPORTANT SAFETY INFORMATION



**WARNING:** Read and understand all instructions and safety information in this manual and on safety decals before assembling or operating this log splitter. Failure to understand may cause serious injury or death. Do not allow anyone to operate this log splitter who has not read this manual. A log splitter can be dangerous if assembled or used improperly. Do not operate this log splitter if you have any questions concerning safe operation. Call our technical support department at 1-888-723-6534 for answer to any questions.



**WARNING:** This product can expose you to chemicals including lead and lead compounds which are known to the State of California to cause cancer and birth defects or other reproductive harm. For more information, go to [www.P65Warnings.ca.gov](http://www.P65Warnings.ca.gov)



This is the safety alert symbol. It is used to alert you to potential personal injury hazards. Obey all safety messages that follow this symbol to avoid possible injury or death.



**DANGER** indicates a hazardous situation which, if not avoided, will result in serious injury or death.



**WARNING** indicates a hazardous situation which, if not avoided, could result in serious injury or death.



**CAUTION** indicates a hazardous situation which, if not avoided, could result in minor or moderate injury.



**NOTICE** is used to address practices not related to personal injury.

### INTENDED USE

**NEVER** use this log splitter for any other purposes than splitting wood. It is designed for this use **only**. Any other use can cause serious injury or death and void warranty.

### PERSONAL PROTECTIVE EQUIPMENT



**BEFORE** operating this log splitter make sure that you wear safety gear such as eye protection, steel toed shoes and tight-fitting gloves (without loose cuffs or draw strings). Hearing protection is required when operating this log splitter.

### SAFETY DECALS

Make sure that all safety warning decals are in good condition and readable. Always replace missing or damaged decals. Contact at 1-888-723-6534 for replacement decals.

**⚠ WARNING**

**To minimize risk to you or others of serious injury or death while towing:**

- Read and understand the owner's manual on how to properly attach the coupler to the hitch ball and how to safety tow.
- Ensure the correct ball size is being used.
- Do not exceed hitch ball or coupler load limits.
- Ensure safety chains are attached prior to towing.
- Do not exceed a maximum towing speed of 45 mph.
- Avoid turning sharply and steep angles.
- Ensure the tightness of the coupler each time before towing.
- Replace the hitch ball or coupler if damaged.
- This product can expose you to chemicals including lead and lead compounds which are known to the State of California to cause cancer and birth defects or other reproductive harm. For more information, go to [www.P65Warnings.ca.gov](http://www.P65Warnings.ca.gov)

PART NUMBER: 20230505001  
LOCATION: TOP, FRONT END OF TONGUE



# IMPORTANT SAFETY INFORMATION

**OPERATOR SAFETY**  
**WARNING**

To minimize the risk of serious injury or death:  
 -Read and thoroughly understand owner's manual and engine manual before assembly, operation, towing and maintenance.  
 -Only one operator permitted. Must operate in operator zone. Keep all bystanders and pets away.  
 -Do not step or reach over splitter during operation.  
 -Load logs by the sides, never by ends.  
 -Keep hands, body and clothing away from moving parts when splitting.  
 -Do not operate indoors.  
 -Do not check for high pressure oil leaks with your hands. Use cardboard.  
 -Wear safety glasses, shoes and hearing devices.  
 -Do not operate if tired or under influence of alcohol or drugs.

**OPERATING INSTRUCTIONS**

1. Place splitter on dry, level surface. Remove debris from work area.
2. Start engine. Advance throttle to max.
3. Place log onto beam, against foot plate.
4. Split wood in direction of grain.
5. Move control handle to EXTEND or RETRACT as required.

**Control Valve**  
 Retract ↑  
 ↓  
 Extend

**Best practices for loading logs for splitting.**

**For Responsive Service**  
**Call 1-888-723-6534**

PART NUMBER: 20230505002  
 LOCATION: TOP OF HYDRAULIC CYLINDER

**DANGER**

**PINCH POINT**  
 Keep Hands Clear

PART NUMBER: 20170425003  
 LOCATION: STRIPPER PLATE, OPERATOR SIDE

**NOTICE**

Do not thread in the dipstick when checking the hydraulic oil level. The oil level needs to be kept on the line below the "MAX" indicated on the dipstick. Never fill the tank above the "MAX" line. Recommended oil viscosity is based on the outside operating temperatures in the table below.

°F	-20	0	10	20	32	40	50	60	80	100											
°C	-30	-20	-10	0	10	20	30	40													
	Solid zone: Recommended										Hatched zone: Acceptable										

AW46  
 AW32  
 Automatic Transmission Fluid

PART NUMBER: 20170425004  
 LOCATION: TOP OF OIL TANK

**WARNING**

Before towing check that beam latch pin is completely locked.

PART NUMBER: 20170425005  
 LOCATION: END OF TOW BAR



## IMPORTANT SAFETY INFORMATION

### GENERAL SAFETY

- **ALWAYS** keep the operator's manual in canister for reference. Reread the manual periodically.
- **ALWAYS** keep all bystanders and pets a minimum of 10 feet away from your work area when operating this log splitter. Only the operator is to be near the log splitter during use.
- **NEVER** actuate the control valve until all people are clear of the work area.
- **NEVER** wear loose clothing or jewelry when operating log splitter. Keep clothing and hair away from all moving parts when operating this log splitter.
- **NEVER** allow adults lacking proper instructions and understanding to operate this log splitter.
- **NEVER** operate the log splitter when under the influence of drugs, alcohol or medication or when otherwise not alert enough to operate this log splitter.
- **DO NOT** allow children to play on, stand upon, climb on or operate the log splitter at any time.

### WORK AREA

- **NEVER** operate the log splitter on wet, icy, slippery or unstable ground.
- **NEVER** operate the log splitter in an enclosed area. Exhaust fumes contain carbon monoxide which are deadly.
- **ONLY** operate the log splitter in good lighting conditions.
- **ONLY** operate the log splitter on level ground. Operating on a slope could cause log splitter to move or logs to fall off.
- **ALWAYS** keep the work area free of debris. Remove split wood around the log splitter immediately to eliminate the possibility of tripping.

### PREPARATION OF THE LOG

Both ends of the log should be cut as square as possible to help prevent the log from moving during splitter operation.

Max log length is 24 inches.

### OPERATION OF THE LOG SPLITTER

**ONLY** operate the log splitter from the operator zone as shown in the diagram. Operating the log splitter in another location can result in serious injury or death.

- **ALWAYS** chock the wheels to prevent movement of the log splitter while in operation.
- **KNOW** how to stop the log splitter and disengage the controls before operating it.
- **NEVER** try to split log against grain.
- **NEVER** try to split two logs at the same time.
- **NEVER** step over the log splitter during operation.
- **NEVER** reach or bend over the log splitter to pick up a log.
- **NEVER** attempt to load the log splitter when the wedge is in motion.
- **NEVER** place hands or feet between the log and splitting wedge during forward or reverse stroke as this could result in serious injury or death.
- **NEVER** use your foot, a rope or any extension device to operate the control lever on the valve. Only use hand.
- **NEVER** touch the muffler and other hot areas of the engine during operation. Wait until the engine cools down.
- **NEVER** move the log splitter while the engine is running. Shut off the engine if you are leaving the log splitter, even for a short period of time.

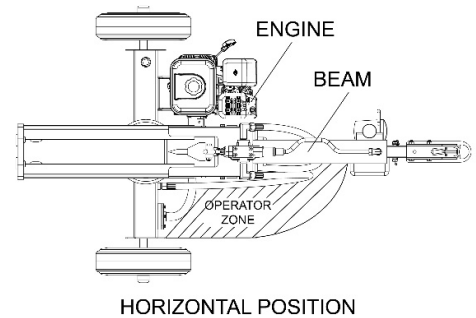

HORIZONTAL POSITION

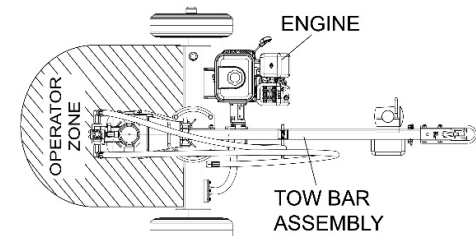

VERTICAL POSITION

### GENERAL REPAIR

- **NEVER** operate your log splitter when it is in poor mechanical condition or in need of repair.
- **NEVER** alter your log splitter in any manner. Such alterations may cause your log splitter to be unsafe and will void the warranty.
- **NEVER** perform any service or repair on your log splitter without first removing the spark plug wire.
- **NEVER** tamper with the engine settings. The maximum engine speed is preset by the manufacturer and is within safety limits. Refer to the engine owner's manual for your particular log splitter.
- **ALWAYS** perform all recommended maintenance procedures before using your log splitter.
- **ALWAYS** check the level of hydraulic oil and engine oil before operation.
- **NEVER** attempt to free a stuck log with hands while log splitter is running.
- **ALWAYS** replace all damaged or worn parts immediately.
- **ALWAYS** periodically check that all nuts, bolts, screws, hydraulic fittings and hose clamps are tight.



## IMPORTANT SAFETY INFORMATION

### **MAINTENANCE & SAFETY**

- The mechanical and hydraulic systems of your log splitter require careful inspection. Be sure to replace damaged hydraulic hoses or hydraulic components.
- **NEVER** check for leaks of hydraulic fluid with your hand. Fluid escaping from a small hole can be almost invisible. Escaping fluid under pressure can have sufficient force to penetrate skin causing **SERIOUS INJURY** or even **DEATH**.  
Leaks can be safely detected by passing a piece of cardboard over the suspected leak and looking for discoloration.
- **NEVER** remove the cap from the hydraulic tank while the log splitter is running. The tank could contain hot oil under pressure which could result in serious injury.
- **NEVER** adjust the relief valve setting. The pressure relief valve on your log splitter is preset at the factory. Only a qualified service technician should perform this adjustment.
- **ALWAYS** seek medical attention immediately if injured by escaping hydraulic fluid. Serious infection or reaction can develop if proper medical treatment is not administered immediately.
- **ALWAYS** be sure system is not under any pressure by shutting off the engine and moving the valve control handle back and forth should it become necessary to loosen or remove any hydraulic fitting.
- **ALWAYS** keep the beam and wedge free of debris buildup.
- Grease Wheel Bearings and tighten all hardware seasonally.

### **FIRE PREVENTION**

- **ONLY** refuel your log splitter in a clear area with no gas fumes or spilled gas.
- **NEVER** operate your log splitter near a flame or spark or smoke during operation. Hydraulic oil and gasoline are flammable and can explode.
- **NEVER** add fuel while the engine is hot or running. Allow the engine to cool before refueling.
- If gasoline has spilled, move the log splitter away from the area of the spill and avoid creating any source of ignition until the spilled gas has evaporated.
- **ALWAYS** securely replace the gas cap.
- **ALWAYS** clean wood debris from the muffler area of the engine.
- **ALWAYS** store gasoline in an approved, tightly sealed container and away from heating appliances. Store the container in a cool, dry place.

### **IMPORTANT NOTE** – (on spark arrester):

As a precautionary measure against possible flying sparks, always take a Class B fire extinguisher with you when operating this log splitter in dry areas. This log splitter is equipped with an internal combustion engine and should not be used on or near any unimproved forest-covered, brush-covered or grass-covered land unless the engine's exhaust system is equipped with a spark arrester meeting applicable local or state laws (if any). If a spark arrester is used, it should be maintained in effective working order by the operator. In the state of California, a spark arrester is required by law. Other states have similar laws. Federal laws apply on federal lands. A spark arrester muffler is optional and available as an accessory at your nearest engine dealer. Always check the legal.

### **TOWING SAFETY**

- **NEVER** carry cargo or wood on your log splitter.
- **NEVER** allow anyone to sit or ride on your log splitter.
- **NEVER** Move your log splitter over hilly or uneven terrain without a tow vehicle or adequate help.
- **NEVER** exceed weight capacity of ball or load limits of coupler.
- **NEVER** exceed 45 mph when towing your log splitter. Towing the log splitter at speeds higher than 45 mph could result in loss of control, damage to the equipment, or serious injury or death. Adjust towing speed for terrain and conditions. Be extra cautious when towing over rough terrain, and avoid sharp turns and steep angles when towing your log splitter.
- **ALWAYS** attach safety chains when towing your log splitter.
- **ALWAYS** confirm coupler tightness each time before towing and after towing 50 miles.
- **ALWAYS** take care when backing up with your log splitter in tow. It could jackknife.
- **ALWAYS** allow for added length of your log splitter when turning, parking and crossing intersections and in all driving situations.
- **ALWAYS** disconnect your log splitter from the towing vehicle before operation.
- **ALWAYS** confirm all local and state regulations regarding towing, licensing, and lights before towing your log splitter.
- **ALWAYS** check before towing to make sure that the log splitter is correctly and securely attached to the towing vehicle and that the safety chains are secured to the hitch or bumper of the vehicle with enough slack to allow turning. Always use a Class I or above, 2" ball for connection to log splitter.
- **ALWAYS** replace ball or coupler if damaged.
- **ALWAYS** turn the fuel shut off valve on the engine to the "OFF" position before towing the log splitter. Failure to do so may result in flooding the engine and damaging engine oil.

# ASSEMBLY INSTRUCTIONS

## TOOLS REQUIRED

- Hammer or Crowbar
- Band Cutter
- 17mm and 19mm Wrenches

## STEP 1: Unpack Unit & Remove Tow Bar

- 1.1 Remove outer carton sleeve then remove sides and top of crate using hammer or crowbar.
- 1.2 Remove the tow bar assembly from the crate.

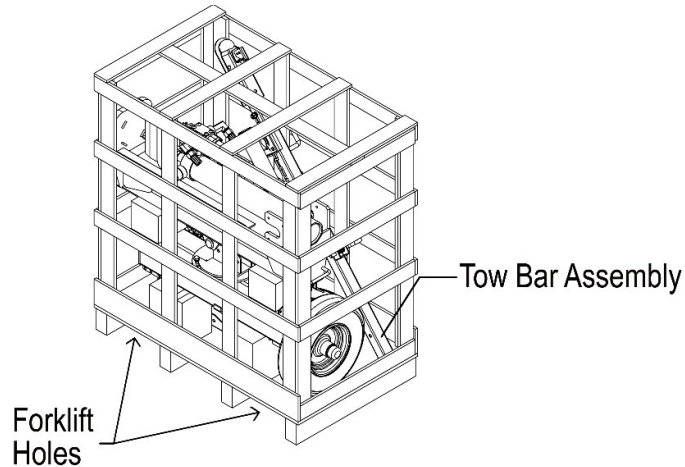

## STEP 2: Fix Handle on Control Valve & Attach the Wheels

- 2.1 Remove the valve handle fix pin and R pin from valve and reinstall with handle in vertical position.
- 2.2 Insert the wheel assembly into the sleeve on the tank and lock it with two sets of items 28 and 29 (M10x55 hex bolts and M10 lock nuts). Install the other side wheel in the same way.

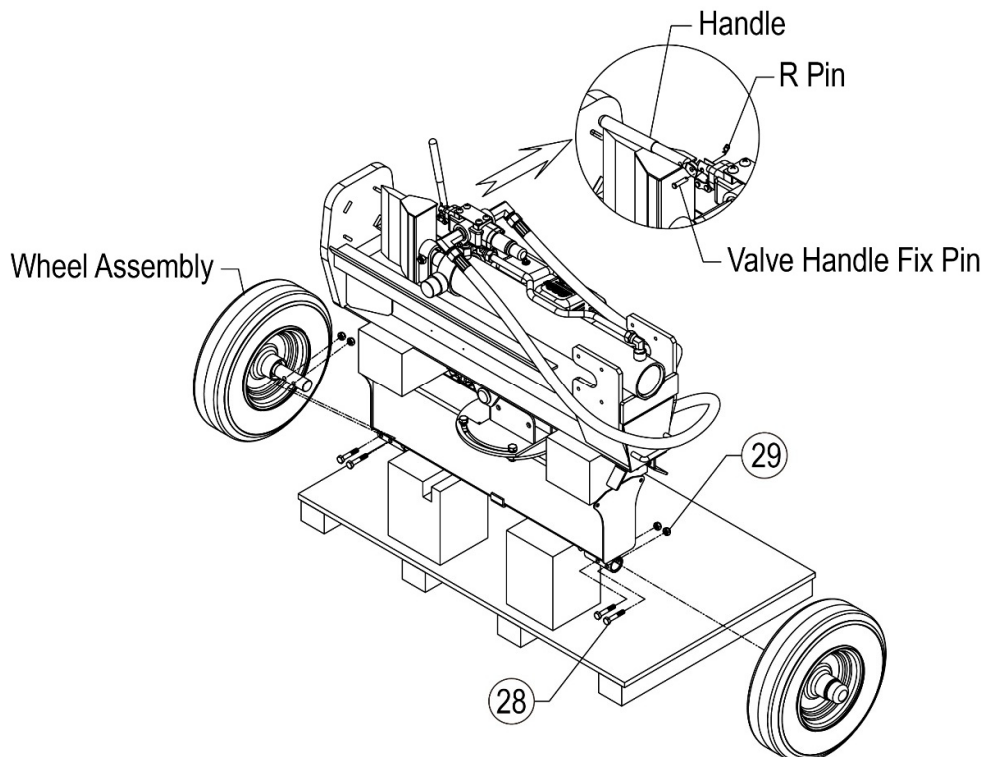

### STEP 3: Attach the Cylinder Assembly

- 3.1 Move the cylinder assembly backward to the position shown in the figure, put on the cylinder cover then lock them with eight sets of items 73, 74 and 75 (M10x25 hex bolts, Ø10 lock washers and Ø10 flat washers).

**Note: Start all the bolts, then tighten on the cylinder cover.**

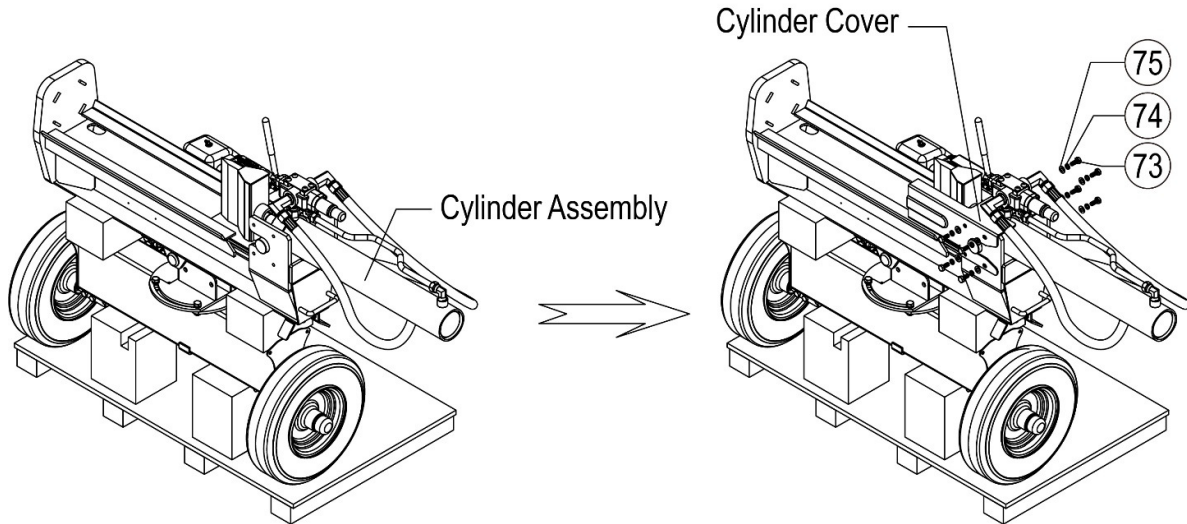

### STEP 4: Rotate and Secure Beam

- 4.1 Remove the two sets of items 56, 57 and 45, that are painted red (M12x35 red hex bolts, Ø12 lock washers and Ø12 flat washers) from the outer portion of the rotating assy.
- 4.2 Loosen the other two bolts on rotating assembly which will allow beam assy. to rotate.
- 4.3 **IMPORTANT!** Before rotating the beam, take off one cardboard honeycomb block between beam and hydraulic reservoir. And place this cardboard honeycomb block besides the crate. Please see below figure of cardboard honeycomb block location.
- 4.4 Rotate the beam 90 degrees towards the front while simultaneously lifting beam to vertical position.
- 4.5 Reinstall the red bolts and tighten the other outer two bolts.
- 4.6 Loosen connector of hydraulic hose with 32mm wrench or adjustable wrench, adjust the hydraulic hose to a non-kinked state, then retighten the connector.

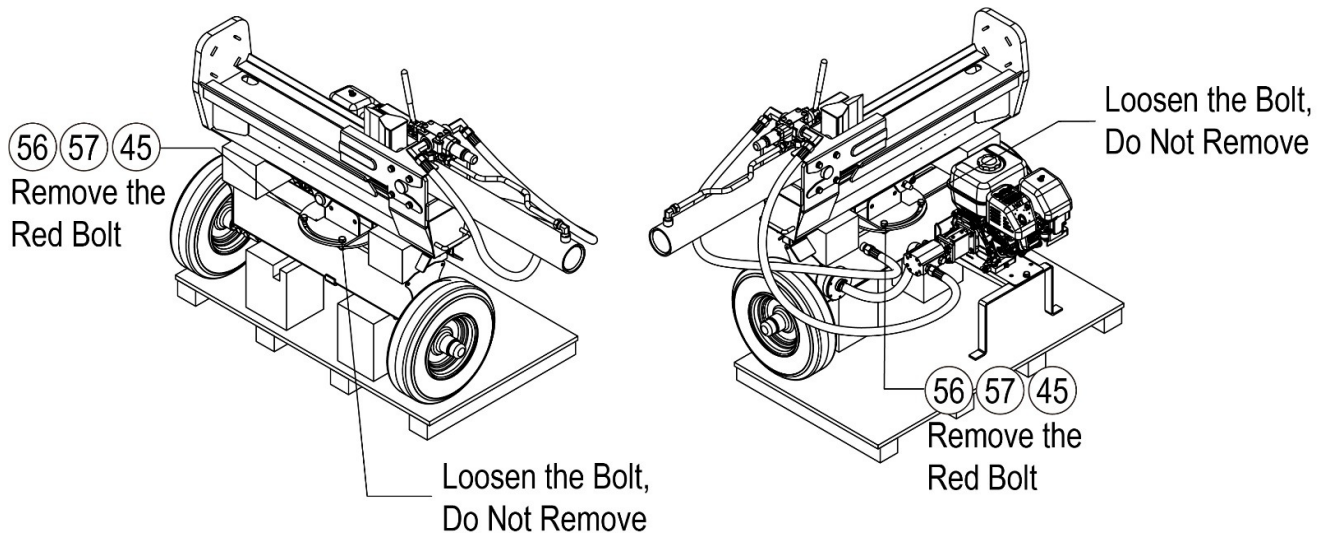



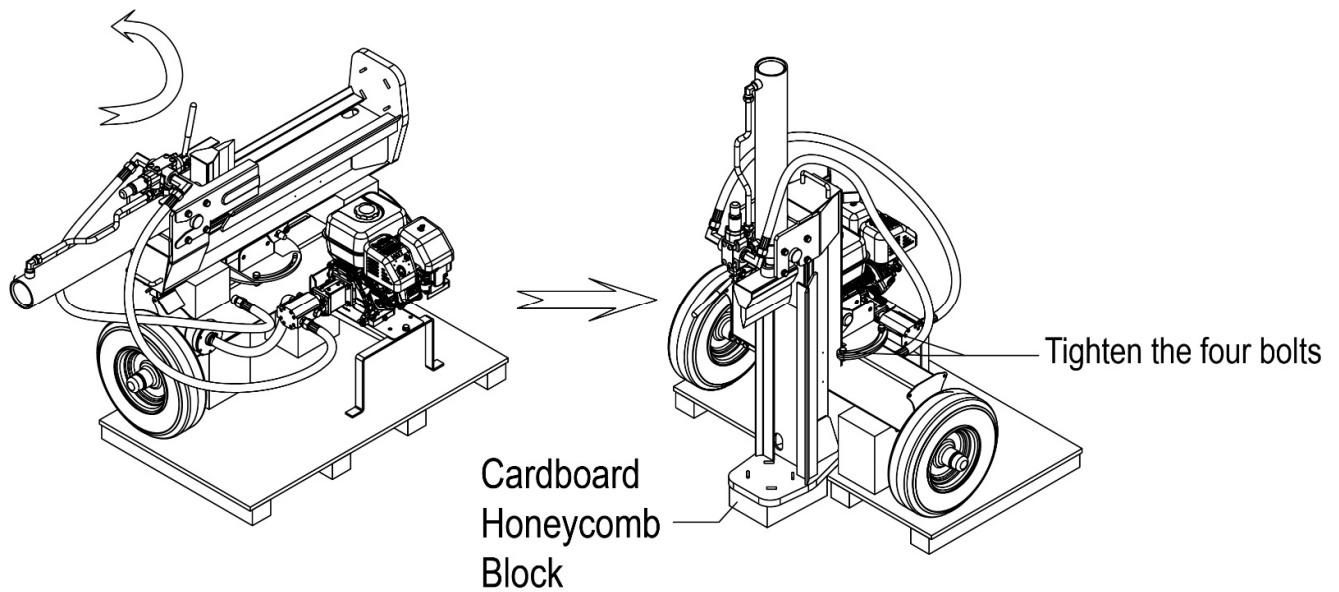
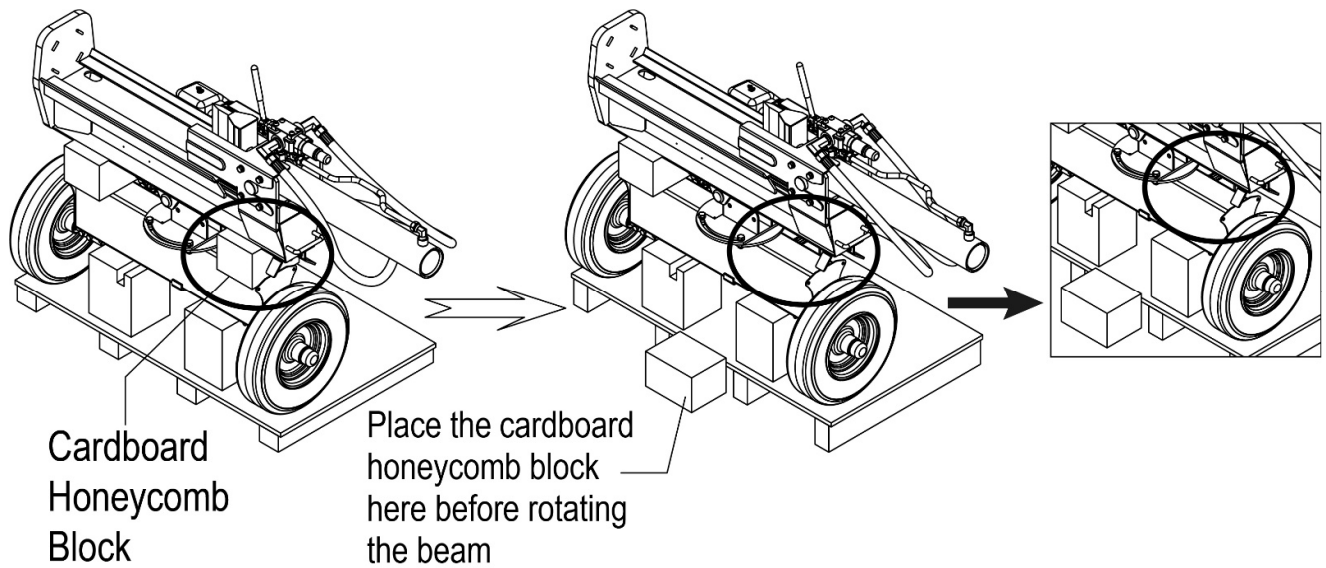

### STEP 5: Rotate the Support Leg

5.1 Pull out the pin on the support leg then rotate the support leg to the down position.

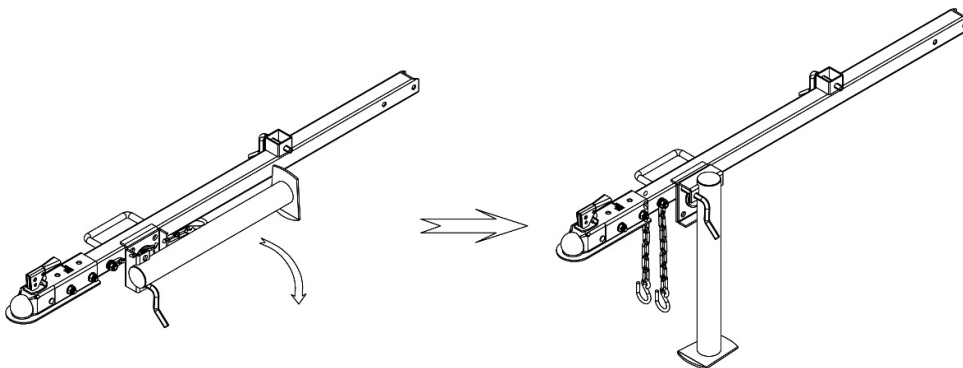

## STEP 6: Attach the Tow Bar Assembly

- 6.1 Insert the tow bar assembly into the rotating mechanism, secure using items 50, 45 and 48 (M12x80 hex bolt, Ø12 flat washer and M12 nylon lock nut).

**Note: when inserting the tow bar, make sure the two hydraulic hoses are on the left side of the tow bar.**

**Do not put on the side with the engine.**

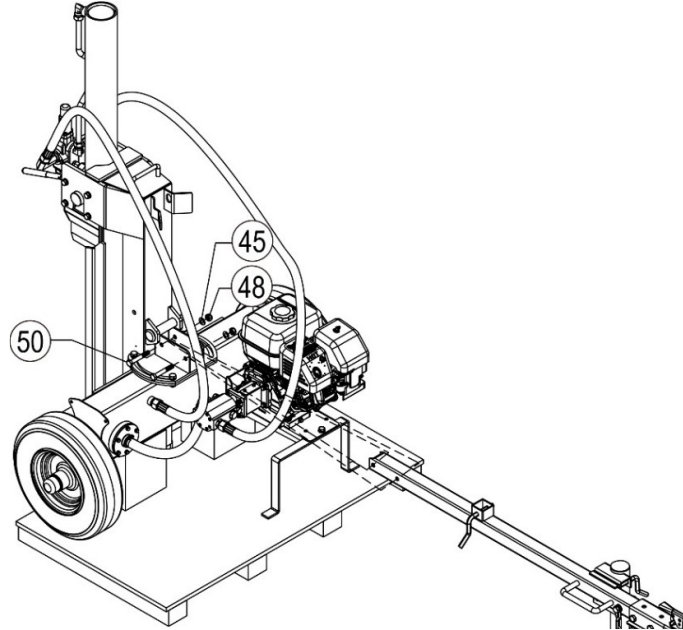

## STEP 7: Remove Completed Unit from Crate Bottom

- 7.1 Remove item 77 (fill plug) from blue bag and replace plastic plug. Plastic plug can be discarded.
- 7.2 Lower the beam to the horizontal position, roll the splitter off of the crate.
- 7.3 Remove the engine support leg with 17mm wrench.
- 7.4 Check to make sure all hardware has been tightened.

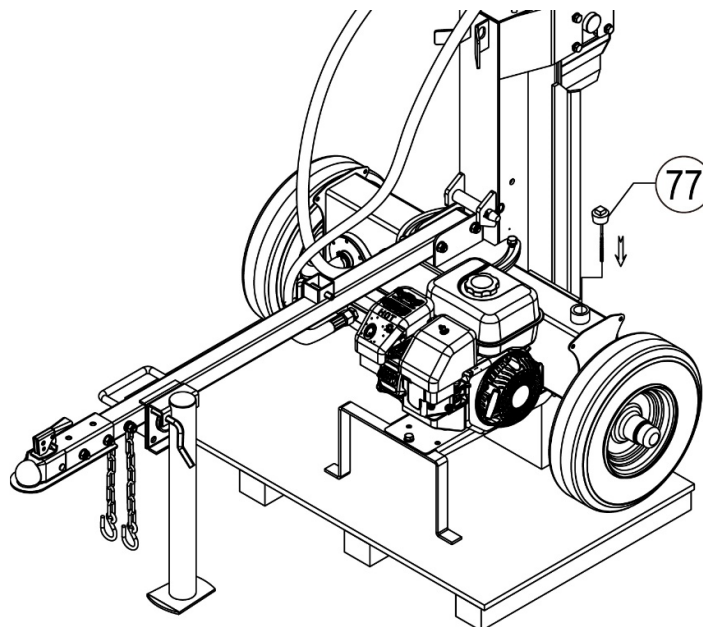

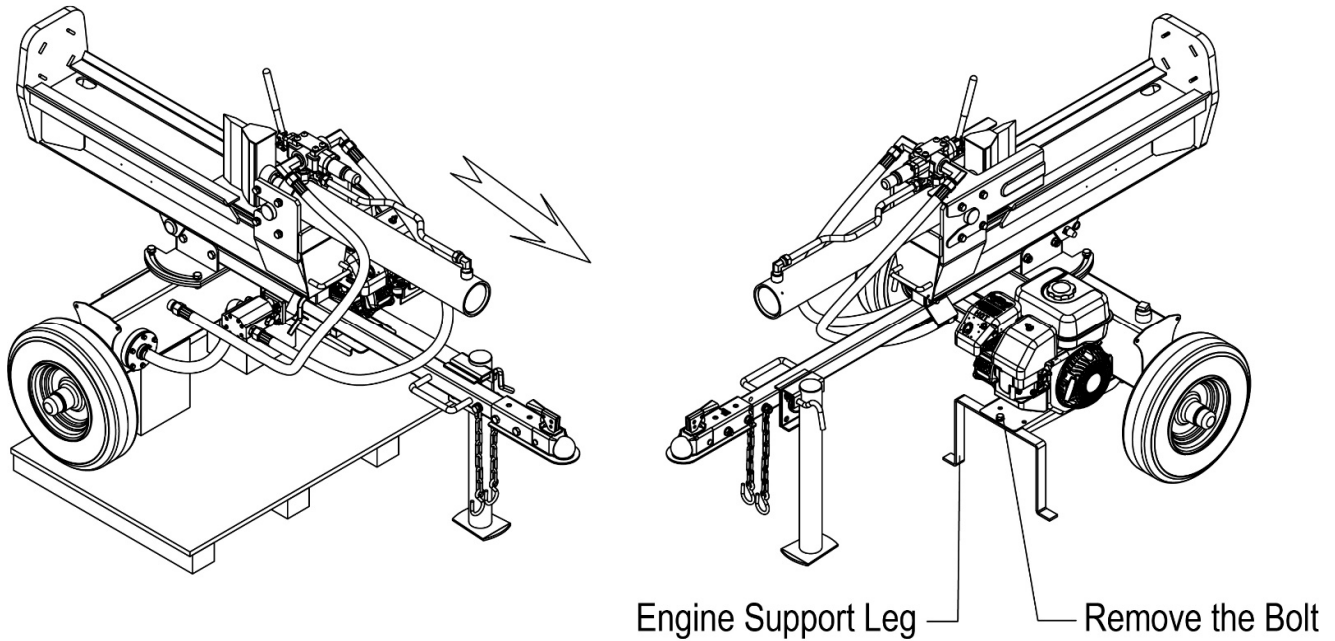

### STEP 8: Check Engine Oil Level

- 8.1 The engine is prefilled with SAE10W-30 (Refer to the Engine Owner's Manual).
- 8.2 Make sure the log splitter is on a level surface
- 8.3 Remove oil fill cap/dipstick, check oil level and add if necessary
- 8.4 Replace oil fill cap/dipstick

**NOTE: During the break-in period check the engine oil level often.**

### CAUTION

DO NOT attempt to crank or start the engine before it has been properly filled with the recommended type and amount of oil. Damage to the log splitter as a result of failure to follow these instructions will void your warranty.

### STEP 9: Check Hydraulic Oil

- 9.1 The log splitter needs to be on a flat level surface before checking or adding the hydraulic oil.
- 9.2 The log splitter was prefilled with 2.9 gallons of AW32 hydraulic oil before shipping. AW46 & universal hydraulic oil are all acceptable types of fluid. **Automatic transmission fluid can be used when operating in temperatures below 32 degrees to enhance engine starting.**
- 9.3 Start engine and use the control lever to extend and retract wedge several times to remove air from the lines.
- 9.4 With the wedge retracted, check hydraulic oil level again and fill if necessary.



## WARNING

DO NOT remove the hydraulic oil fill cap when the engine is running or hot. Hot oil can escape causing severe burns. Always allow the log splitter to cool completely before removing the hydraulic oil cap. High fluid pressure and temperatures are created in the hydraulic log splitters. Hydraulic fluid will escape through a pin-size hole opening and can puncture skin and cause severe blood poisoning. Inspect hydraulic system regularly for possible leaks. **Never check for leaks with your hand while the system is pressurized. Seek medical attention immediately if injured by escaping fluid.** Make sure all fittings are tight and secure before applying pressure. Relieve system pressure before servicing. Make sure the hydraulic hoses do not touch any hot surfaces or cutting areas. Hoses need to be positioned where they are clear from the engine and cutting wedge. To avoid serious bodily injury always inspect the hoses before operating the log splitter.

## STEP 10: Add Gasoline to the Engine

- 10.1 Use only clean, fresh, regular unleaded fuel with a minimum 87 octane rating.
- 10.2 DO NOT mix oil with fuel.
- 10.3 Remove the fuel cap and slowly add fuel to the tank. DO NOT overfill allow approximately ¼ inch of space for fuel expansion.
- 10.4 Screw on the fuel cap and wipe away any spilled fuel.



## DANGER

Log splitter engine exhaust contains carbon monoxide, a colorless, odorless, poison gas. Breathing carbon monoxide will cause nausea, dizziness, fainting or death. If you start to feel dizzy or weak, get to fresh air immediately. Operate log splitter outdoors only in a well-ventilated area. DO NOT operate the log splitter inside any building, enclosure or compartment. DONOT allow exhaust fumes to enter a confined area through windows, doors, vents or other openings. **DANGER CARBON MONOXIDE, using a log splitter indoors CAN KILL YOU IN MINUTES.**



## CAUTION

Fuel and fuel vapors are highly flammable and extremely explosive. Fire or explosion can cause severe burns or death. Unintentional startup can result in entanglement, traumatic amputation or laceration. Only use regular unleaded gasoline with a minimum 87 octane rating. DO NOT mix oil and gasoline together. Fill tank approximately ¼" below the top of the tank to allow for fuel expansion. DO NOT fill fuel tank indoors or when the engine is running or hot. DO NOT light cigarettes or smoke when filling the fuel tank.

# CONTROLS AND FEATURES IDENTIFICATION

Below Diagram identifies major component described in this manual.

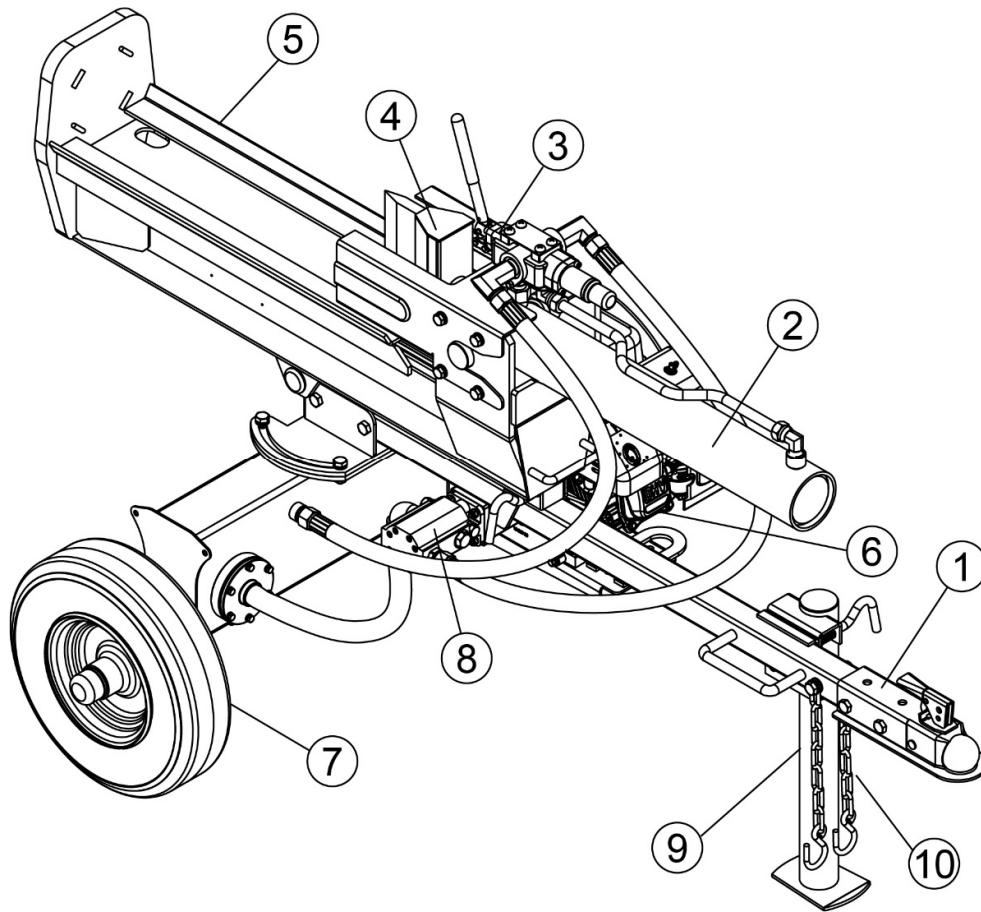

- 1) **2" Ball Coupler**
- 2) **Hydraulic Cylinder**
- 3) **Control Valve**
- 4) **8" Wedge**
- 5) **Beam**
- 6) **Engine**
- 7) **Tire / Wheel Assembly**
- 8) **Gear Pump**
- 9) **Support Leg**
- 10) **Chains**

# OPERATING INSTRUCTIONS



***WARNING:*** Read and understand all instructions and safety information in this manual and on safety decals before assembling or operating this log splitter. Failure to understand may cause serious injury or death. Do not allow anyone to operate this log splitter who has not read this manual. A log splitter can be dangerous if assembled or used improperly. Do not operate this log splitter if you have any questions concerning safe operation. Call our technical support department at 1-888-723-6534 for answer to any questions.



***CAUTION:*** DO NOT START OR RUN THE ENGINE BEFORE CHECKING OIL IN THE HYDRAULIC RESERVOIR AND OIL IN THE ENGINE.

## **ENGINE OIL RECOMMENDATIONS**

Engine is supplied with 10W-30 oil. Refer to the engine owner's manual for information on oil temperature ranges and grades to use. Engine oil capacity is 17 ounces.

After the hydraulic reservoir and the engine crankcase are filled with oil, start the engine. The hydraulic pump should prime itself. With the engine running, move the control valve lever toward the foot plate. This will cause the cylinder to extend and expel air. When the cylinder is fully extended, retract it. Repeat this procedure several times. After this procedure check oil level once again. NOTE: If the tank is overfilled it will tend to expel oil from the breather cap when the cylinder is retracted. Cycle the cylinder again until it has a constant speed indicating that all air has been expelled.

## **STARTING INSTRUCTIONS**

Refer to the Rato Owner's manual for complete information on starting, maintenance and specifications.

209cc Rato Engine

- a) Check that "ON"/"OFF" switch is in the on position.
- b) Move the throttle lever to "FAST". Always operate the engine with throttle lever in the "FAST" position.
- c) Move choke control lever to "CHOKe" position.
- d) Grasp rope handle and pull slowly until resistance is felt. Then pull rapidly to start engine and avoid engine kickback.
- e) Allow the engine to warm up. If operating in warm weather, move the choke control lever toward "RUN" a short distance at a time over several seconds. For cold weather operation do this procedure over several minutes. Operate with choke lever in the "RUN" position.
- f) To stop engine, move "ON"/"OFF" switch to "OFF".



***CAUTION:*** TURN FUEL SHUT OFF VALVE TO THE "OFF" POSITION PRIOR TO TOWING. FAILURE TO DO SO MAY RESULT INFLOODING THE ENGINE AND DESTROYING ENGINE OIL.

**NOTE:** The engine maximum governed speed is preset at the factory at 3800±100 RPM no load speed. When splitting wood the throttle should be set at the maximum speed to develop the horsepower required for the pump.

## **OPERATION**



***WARNING:*** See safety information related to operation of the log splitter on page 5 and 6 of this manual. Make sure that you have the recommended personal protective equipment described on page 3.

- 1) Set up the log splitter in a clear, level area and chock the wheels.
- 2) For horizontal operation place a log on the beam against the foot plate. Make sure the log is securely on the foot plate and up against the beam. To split wood in the vertical position, release the pin on the beam latch located near the front end of the beam. Tilt the beam up until the foot plate is sitting squarely on the ground and the log splitter is stable. Place the log on the foot plate up against the beam. When the beam is returned to the horizontal position make sure the beam latch pin is secure.

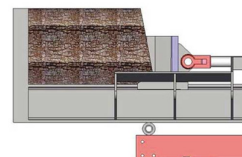

**Best practices for loading logs for splitting.**

# OPERATING INSTRUCTIONS

3) Move control valve handle so that the cylinder will drive the wedge into the log. Extend the cylinder until the log splits or to the end of its stroke. If the log has not completely split after the cylinder has reached the end of its extension, retract the cylinder.

**IMPORTANT:** Leaving the valve in the “actuate” position at the end of the stroke can accelerate wear on hydraulic component. Do not split logs with unsquared ends.

**NOTE:** For operation in wooded areas, obtain a spark arrestor for the exhaust system. See the engine operating and maintenance manual and check with your authorized Rato service center. See also Fire Prevention on page 6 of this manual.

## **TOWING**

This log splitter is equipped with pneumatic tires, a Class I or above coupler (2 in. diameter ball required) and safety chains. Before towing, the safety chains must be secured to the hitch or bumper of the vehicle. Local regulations should be checked regarding licensing, lights, towing, etc. Turn fuel shut off valve on the engine to the “Off” position prior to towing. Failure to do so may result in flooding the engine. Do not exceed 45 mph when towing this log splitter. See also Towing Safety on page 6 of this manual.

## **MAINTENANCE**

- 1) Consult the operating and maintenance instructions of the engine manufacturer for engine care and maintenance.
- 2) Always check the oil level of the hydraulic reservoir before operation. Operating the log splitter without an adequate oil supply will cause severe damage to the pump.
- 3) To drain the hydraulic oil, remove drain plug fitting on the bottom of the tank. It is located just to the right of the oil filter.
- 4) If the wedge needs sharpening, it can be removed and sharpened.
- 5) Clean the breather cap after 25 hours of operation. Clean it more often when operated in dusty conditions. To clean, remove the breather cap from the tank and flush with solvent or blow out with air.
- 6) See also General Repair and Maintenance Safety on page 5 and 6 of this manual.
- 7) All replacement parts must meet manufacturer’s specifications
- 8) Grease Wheel Bearings and tighten all hardware seasonally.

# OPERATING INSTRUCTIONS

## HORIZONTAL POSITION

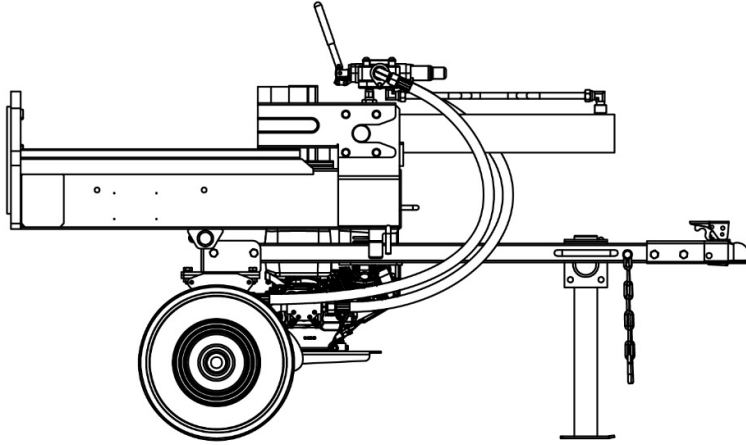

Position used most commonly.

## VERTICAL POSITION

1. Pull beam lock pin
2. Rotate beam to vertical position by lifting end of beam.

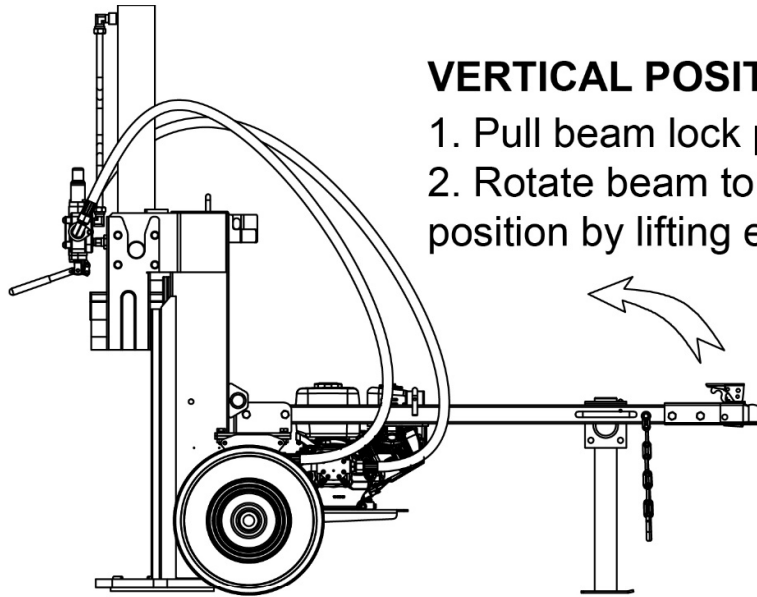

Position commonly used for splitting large logs.

## FOR VEHICLE TOWING

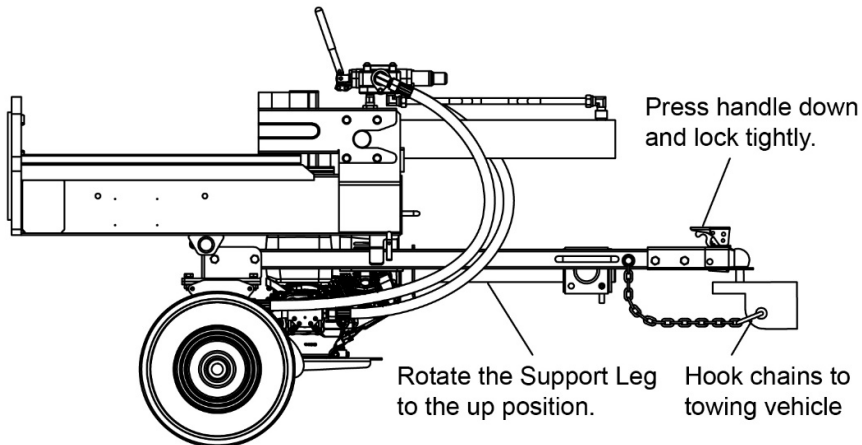

Press handle down and lock tightly.

Rotate the Support Leg to the up position.

Hook chains to towing vehicle



# TROUBLESHOOTING

<b>Problem</b>	
Cylinder rod will not move	SOLUTION: A,D
Slow cylinder rod speed when extending or retracting	SOLUTION: A,B,D,I
Wood will not split or splits extremely slowly	SOLUTION: A,B,D,G,I
Valve will not stay in detent or will not kick out of detent position	SOLUTION:H
Engine bogs down during splitting	SOLUTION: This is normal
Engine stalls under low load condition	SOLUTION: L
Engine will not start	SOLUTION: C,E,F
Engine is difficult to turn over and will not start when cold	SOLUTION:J
Engine runs but cylinder does not move	SOLUTION: D,K
<b>Cause</b>	<b>Solution</b>
<b>A</b> -Insufficient oil to pump	Check oil level in reservoir
<b>B</b> -Air in oil	Check oil level in reservoir
<b>C</b> -Low engine oil	Check and add engine oil
<b>D</b> -Blocked hydraulic lines	Check for restriction
<b>E</b> -“ON”/“OFF”	Move to “ON” position
<b>F</b> -Fuel shut off in “OFF” position	Move to “ON” position
<b>G</b> -Damaged control valve	Return control valve for authorized repair
<b>H</b> -Detent setting incorrect	Remove plastic cap on valve and adjust detent kick out pressure
<b>I</b> -Internally damaged cylinder	Return cylinder for authorized repair
<b>J</b> -Cold ambient temperature	Cold weather (below 32°) can result in difficult engine starting. Change to ATF.
<b>K</b> -Broken pump / Engine coupler	Check and replace coupler
<b>L</b> -Defective pump or engine	Contact service center

## SPECIFICATIONS

Max. Splitting Force ..... 20 Ton

Cycle Time ..... 8.5 Sec

(Cycle time can vary with many mechanical and environmental factors, our published cycle time is for ideal conditions)

Wedge Height ..... 8" Hardened Steel

Gear Pump ..... 14 GPM, 2-Stage

Hydraulic Oil ..... AW32, AW46 & Universal Hydraulic Oil

Hydraulic Capacity ..... 3.96 Gallon

Max. Log Length ..... 24"

Hydraulic Cylinder ..... 3<sup>1</sup>/<sub>2</sub>" x 22"

Wheel Size ..... 4.8-8 wheel with 16" outside diameter D.O.T tires

Hitch Type ..... 2" Ball Coupler

Max. Towing Speed ..... 45 MPH

Manual Start Engine ..... 209cc

***NOTE: For Engine Details Refer to the Engine Owner's Manual.***

# DRAWING & PARTS LIST

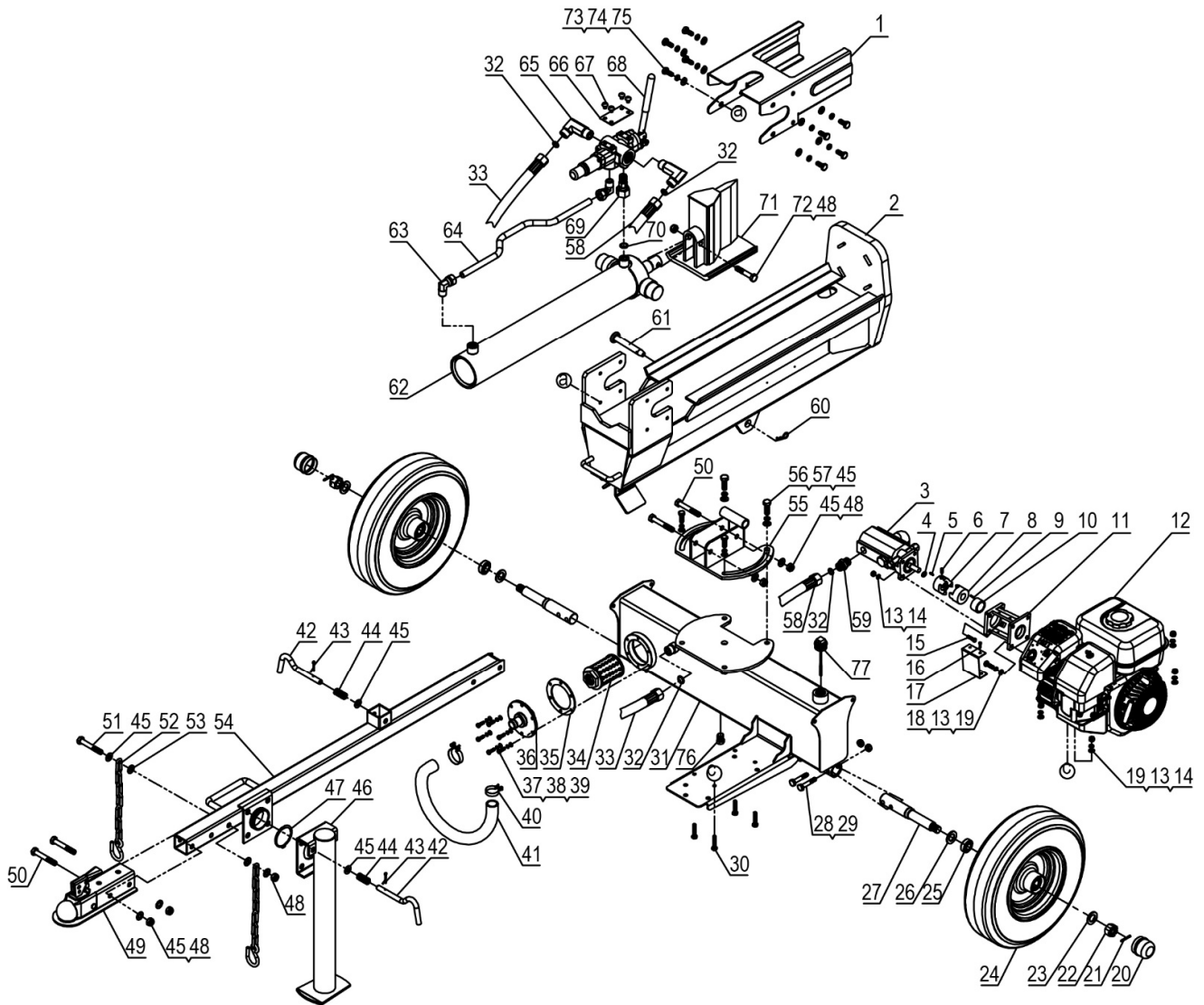

## DRAWING & PARTS LIST

Ref#	Drawing No.	Description	Qty
1	LSP2001-00001	Cylinder Cover	1
2	LSP2001-01000-R186C	Beam Weldment	1
3	25001	Gear Pump 13/1.8	1
4	LSP25-10008-FH	Steel Wire Snap Ring for Shaft	1
5	8801-3.2*3.2*25	Gear Pump Flat Key	1
6	9121-06010-FH	Screw M6x10	1
7	LSP25-10003-FH	Gear Pump Coupling	1
8	LSP25-10002-FH	Engine Coupling	1
9	8801-4.78*4.78*43	Engine Flat Key	1
10	LSP25-10004-DX	Engine Axle Sleeve	1
11	LSP25-10005	Gear Pump Stand	1
12	LSP25-10001	Engine	1
13	9306-08000-DX	Lock Washer Ø8	12
14	9206-08000-DX	Nylon Lock Nut M8	8
15	9101-08030-DX8.8	Hex Bolt M8x30	4
16	9101-05010-DX8.8	Hex Bolt M5x10	4
17	LSP25-10006	Connector Cover	1
18	9101-08025-DX8.8	Hex Bolt M8x25	4
19	9301-08000-DX	Flat Washer Ø8	8
20	LSP25-00009-DX	Axle Cap	2
21	9404-04036-DX	Cotter Pin Ø4x36	2
22	LSP25-00020-FH	Hex Slotted Thin Nut M20	2
23	9301-20000-DX	Flat Washer Ø20	2
24	LSP25-14000-B	Wheel Assembly	2
25	L44643	Tapered Roller Bearing	4
26	LSP25-14002	Oil Seal	2
27	LSP3700-00003	Wheel Axle	2
28	9101-10055-DX8.8	Hex Bolt M10x55	4
29	9206-10000-DX	Nylon Lock Nut M10	4
30	9101-08040-DX8.8	Hex Bolt M8x40	4
31	LSP2001-03000-RB4009	Hydraulic Reservoir	1
32	9901-14*2.5	O Ring Ø14x2.5	4
33	LSP2001-00002	Low Pressure Hydraulic Hose	1
34	LSP25-00022	Oil Filter	1
35	LSP25-00021-DX	Rubber Washer	1
36	LSP25-15000-DX	Filter Fixed Plate	1
37	9101-06020-DX8.8	Hex Bolt M6x20	6
38	9306-06000-DX	Lock Washer Ø6	6

<b>Ref#</b>	<b>Drawing No.</b>	<b>Description</b>	<b>Qty</b>
39	9301-06000-DX	Flat Washer Ø6	6
40	LSP25-00011	Clamp	2
41	LSP30-00008	Clear Oil Pipe	1
42	LSP2501-00008-DX	Pin	2
43	9404-03030-DX	Cotter Pin Ø3x30	2
44	LSP25-00003-DX	Spring	2
45	9301-12000-DX	Flat Washer Ø12	12
46	LSM30-07000-RB4009	Support Leg	1
47	9304-62000-FH	Circlip for Shaft	1
48	9206-12000-DX	Nylon Lock Nut M12	6
49	Z103	2" Coupler	1
50	9101-12080-DX8.8	Hex Bolt M12x80	4
51	9101-12090-DX8.8	Hex Bolt M12x90	1
52	LSP25-11000-DX	Chain Assembly	2
53	LSP25-00015-DX	Thick Washer	2
54	LSP2001-04000-RB4009	Tow Bar Assembly	1
55	LSP2001-05000	Outer Rotating Mechanism	1
56	9101-12035-DX8.8	Hex Bolt M12x35	4
57	9306-12000-DX	Lock Washer Ø12	4
58	LSP2001-00003	High Pressure Hydraulic Hose	1
59	LSA22-00005-DX	Gear Pump Connector	1
60	LSP25-00012-DX	R Pin	1
61	LSP3700-00001-DX	Hitch Pin	1
62	LSP2001-08000-RB4009	Cylinder	1
63	LSP25-06000-DX	Connector	2
64	LSP2001-00004-DX	Metal Tube	1
65	LSA22-00001-DX	Angle Extension Joint	2
66	LSA22-00025	Plate	1
67	9110-08010-DX	Screw M8x10	4
68	LSA22-09000	Control Valve	1
69	LSP25-17000	Combination Connector	1
70	9901-15*2.5	O Ring Ø15x2.5	1
71	LSP2001-02000-RB4009	Wedge	1
72	9101-12065-DX8.8	Hex Bolt M12x65	1
73	9101-10025-DX8.8	Hex Bolt M10x25	8
74	9306-10000-DX	Lock Washer Ø10	8
75	9301-10000-DX	Flat Washer Ø10	8
76	LSP25-00010-DX	Oil Plug	1
77	LSP25-13000	Fill Plug	1

# LIMITED WARRANTY

## **Warranty**

For 2 years from the date of purchase YTL International will replace or repair defects in material and workmanship for the original purchaser of the log splitter. For 2 years the engine warranty is covered per the engine manufactures warranty. For 1 year from date of purchase YTL International will replace the hydraulic system component parts. The warranty will not apply to any unit which was not assembled correctly, misused, overloaded or which has been used or operated contrary to our instructions, or which has been repaired or altered by anyone other than a service representative authorized by YTL International Inc.

## **Warranty Exclusions**

This warranty does not cover cosmetic defects such as paint, decals or wear items such as tires. This warranty will not cover failures or problems due to acts of God, or events or forces beyond the control of the manufacturer.

## **Normal Wear Exclusion**

The log splitter needs periodic service to perform well. This warranty does not cover repair when normal use has exhausted the life of a part or the equipment as a whole.

## **Installation, Use and Maintenance Exclusion**

This warranty will not apply to parts and/or labor if the log splitter has been misused, neglected, involved in an accident, abused, loaded beyond its limits, modified or assembled incorrectly. Normal maintenance is not covered under this warranty.

## **Limits of Implied Warranty and Consequential Damage Exclusion**

YTL International disclaims any obligation to cover any loss of time, use of this product, freight, or any incidental or consequential claim by anyone from using this log splitter. THIS WARRANTY IS IN LIEU OF ALL OTHER WARRANTIES, EXPRESS OR IMPLIED, INCLUDING WARRANTIES OF MERCHANTABILITY OR FITNESS FOR A PARTICULAR.

An exchange unit will be subject to the original warranty. The length of the warranty governing the exchanged unit will have the date as the purchase date of the original unit. This warranty gives you certain legal rights which may change from state to state. Your state may also have other rights you may be entitled to that are not listed within this warranty.

## **Contact Information**

YTL International Inc.  
17517 Fabrica Way Suite H  
Cerritos, CA 90703  
Phone: (888) 723-6534  
Email: [parts@ytlinternational.com](mailto:parts@ytlinternational.com)

## **Distributed by:**

Tractor Supply Company  
5401 Virginia Way  
Brentwood, TN 37027  
Website: [www.tractorsupply.com](http://www.tractorsupply.com)

## ***Contact Information below for Warranty and Service***

### **Log Splitter Parts and Service:**

Toll Free (888) 723-6534