

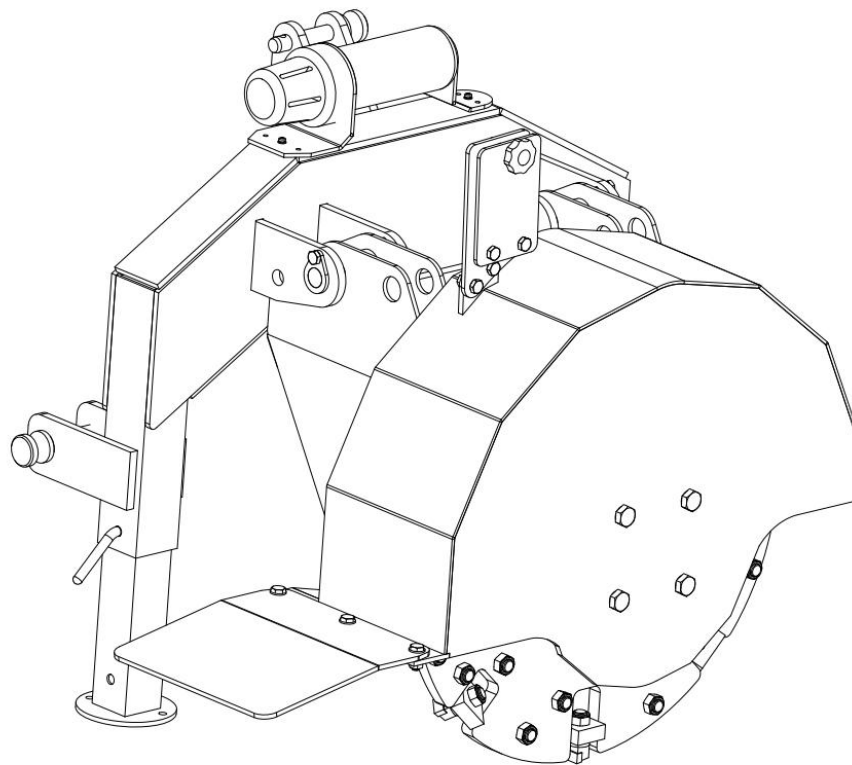

# STUMP GRINDER OWNER'S MANUAL



**WARNING:** Read carefully and understand all INSTRUCTIONS before operating. Failure to follow the safety rules and other basic safety precautions may result in serious personal injury.

20230415

**Model # TMG-243PT**

Page 1 of 26

# TABLE OF CONTENTS

<b>TABLE OF CONTENTS</b>	<b>1</b>
<b>INTRODUCTION</b>	<b>3</b>
<b>INTENDED USE</b>	<b>4</b>
<b>TECHNICAL SPECIFICATIONS</b>	<b>4</b>
TOOLS REQUIRED	4
OVERALL DIMENSIONS	5
3-POINT HITCH DIMENSIONS	6
<b>GENERAL SAFETY RULES</b>	<b>7</b>
<b>WORK AREA / PERSONAL SAFETY</b>	<b>8</b>
<b>MACHINE USE AND CARE</b>	<b>10</b>
1. DEFLECTOR	10
2. MANUAL TUBE	11
<b>SET-UP PROCEDURES</b>	<b>12</b>
TRIMMING THE PTO SHAFT	13
PTO SHAFT CLUTCH RUN-IN	15
FLYWHEEL TOOTH TORQUING	16
<b>EQUIPMENT OPERATION</b>	<b>17</b>
STUMP GRINDING PROCEDURE	20
INCORRECT GRINDING PROCEDURES	21
PULLING THROUGH THE CENTRE	21
GRINDING LEFT-TO-RIGHT	21
CHAINSAW HOLDER	22
STORAGE	22
<b>MAINTENANCE</b>	<b>23</b>
REPLACING TEETH	23
<b>DIAGRAM &amp; PARTS LIST</b>	<b>25</b>
<b>WARRANTY</b>	<b>25</b>
<b>NOTES</b>	<b>26</b>

# INTRODUCTION

Thank you very much for choosing this product! For future reference, please complete the owner's record below:

## OWNER'S RECORD

Please take a moment to record the following information about your stump grinder. If you need to call for assistance, please be ready to provide your model and serial numbers. This information will allow us to help you more quickly when you call.

### MODEL NUMBER

### SERIAL NUMBER

### DATE OF PURCHASE

Save the receipt and these instructions. It is important that you read the entire manual to become familiar with this product before you begin using it.

This machine is designed for certain applications only. We strongly recommend that this machine not be modified and/or used for any application other than that for which it was designed. If you have any questions relative to a particular application, DO NOT use the machine until you have first contacted us to determine if it can or should be performed with the product.

For technical questions and replacement parts, please call **1-218-943-6290**.

## INTENDED USE

This stump grinder is designed for grinding stumps.

## TECHNICAL SPECIFICATIONS

Item	Specification
Recommended Horsepower	20 - 45 hp
Flywheel Diameter	24" (610 mm)
Number of Teeth	34
Tooth	Grade 8.8 Carbide Steel, Bolt-in
Tooth Torque Specification	160 ft•lb (215 N•m)
Required PTO Speed	540 rpm
Maximum Cutting Depth Per Pass	5" (127 mm)
Maximum Depth Below Grade	6" (152 mm)

## TOOLS REQUIRED

Tool	Specification	Use
Phillips Head Screwdriver	No. 3	Assembly
Wrench/Socket	13 mm (2X)	Assembly
Wrench/Socket	16 mm (2X)	PTO Clutch Run-In
Wrench/Socket	17 mm	PTO Clutch Lock Pin
Wrench/Socket	24 mm	Tooth Replacement
Torque Wrench	Capable of 160 ft•lb (215 N•m)	Multiple
Calliper*	Vernier, Dial, or Digital	PTO Clutch Run-In
Hacksaw**		PTO Trimming
Coloured Pencil/Marker		PTO Clutch Run-In

\* Recommended but not required.

\*\* Only if PTO shaft requires trimming. See [\*\*\*Trimming the PTO Shaft\*\*\*](#) section for more detail.

# OVERALL DIMENSIONS

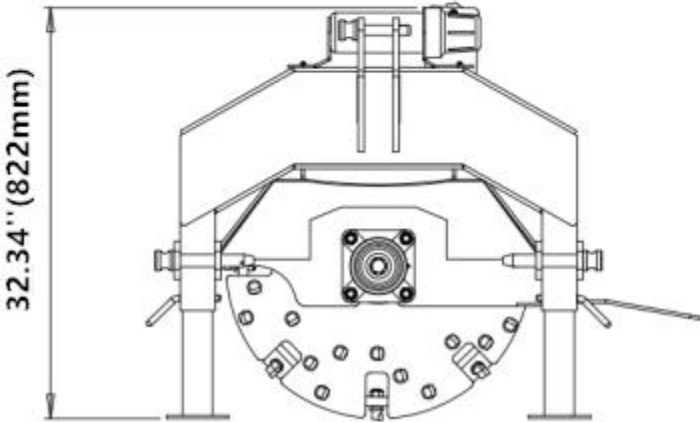
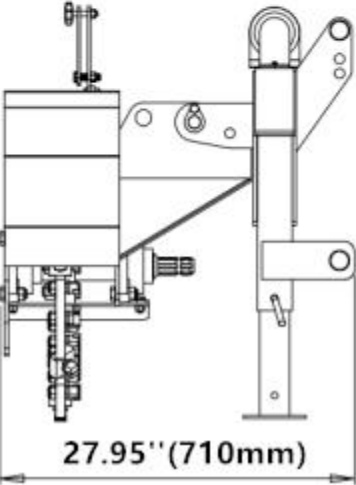
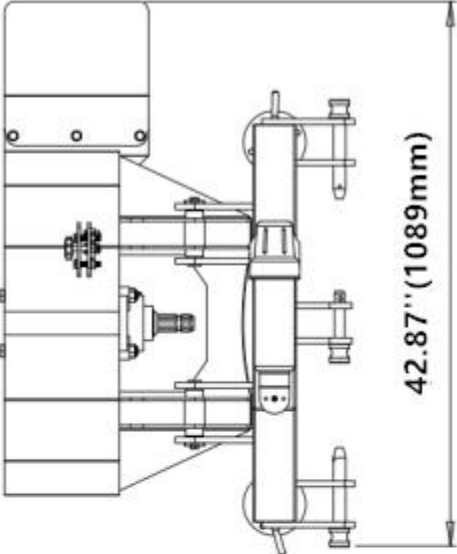

# 3-POINT HITCH DIMENSIONS

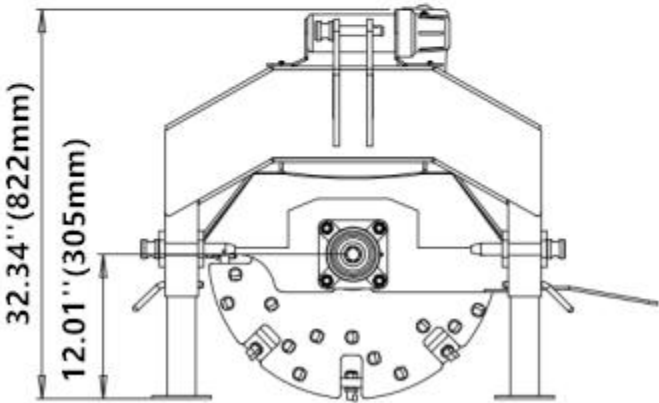
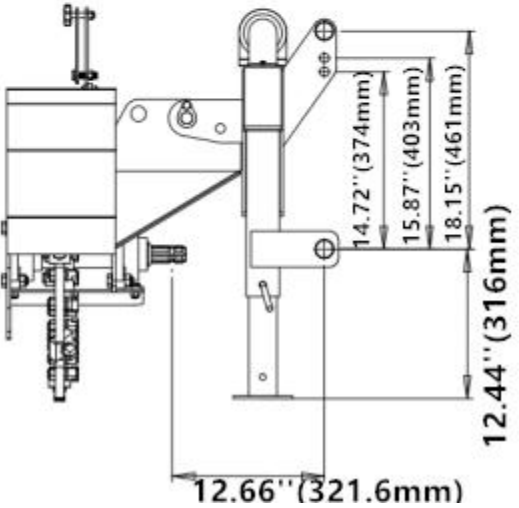
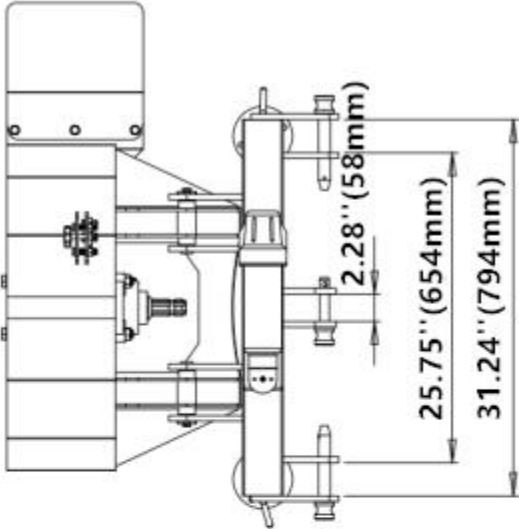

## GENERAL SAFETY RULES



### WARNING!

Read and understand all instructions. Failure to follow all instructions listed below may result in electric shock, fire, and/or serious injury.



### WARNING!

The warnings, cautions, and instructions discussed in this instruction manual cannot cover all possible conditions or situations that could occur. It must be understood by the operator that common sense and caution are factors which cannot be built into this product but must be supplied by the operator.

- All Federal and State laws and any regulation having jurisdiction covering the safety requirements for use of the machine take precedence over the statements in this manual. Users of this machine must adhere to such regulations.
- Only people that have read and understood these instructions are permitted to use the stump grinder.
- Inspect the stump grinder and tractor at the beginning of every working day and repair any defects.
- Stop the engine and make sure that the machine will not start accidentally while repairing defects or performing maintenance.
- Do not disable or remove the stump grinder's safety devices.
- **Always locate and mark buried wires, cables, and pipelines prior to grinding.**

## WORK AREA

- **Keep work area clean**, free of clutter, and well lit. Cluttered and dark work areas can cause accidents.
- **Keep children and bystanders** away while operating a machine. Distractions can cause you to lose control, so visitors should remain at a safe distance from the work area.
- **Be alert of your surroundings.** Using a machine in confined work areas may put you dangerously close to sharp tools and rotating parts.

## PERSONAL SAFETY

- **Stay alert**, watch what you are doing and use common sense when operating machinery. Do not use a machine when you are tired or under the influence of drugs, alcohol, or medication. A moment of inattention while operating machinery may result in serious personal injury.
- **Dress properly.** Do not wear loose clothing, dangling objects, or jewelry. Keep your hair, clothing, and gloves away from moving parts. Loose clothes, jewelry, or long hair can be caught in moving parts. Air vents often cover moving parts and should be avoided.
- **Use safety apparel and equipment.** Use safety goggles or safety glasses with side shields which comply with current national standards, or when needed, a face shield. Use a dust mask in dusty work conditions. This applies to all persons in the work area. Also use non-skid safety shoes, hardhat, gloves, dust collection systems, and hearing protection when appropriate.
- **Do not overreach.** Keep proper footing and balance at all times.
- **Remove adjusting keys or wrenches** before connecting to the power supply or turning on the machine. A wrench or key that is left attached to a rotating part of the machine may result in personal injury.
- **Never conduct any maintenance or make any other adjustments while the tractor engine is running.** Always shut the tractor engine off, remove the ignition key, and keep the engine off before carrying out any of the following procedures. Consult your tractor's operator manual for safe shutdown procedures to prevent accidental ignition.
- **Never** allow passengers to ride on the stump grinder.



# STUMP GRINDER USE AND CARE

- **Always be sure the operator is familiar** with proper safety precautions and operation techniques before using the stump grinder.
- **Do not force the stump grinder.** Stump grinder do a better and safer job when used in the manner for which they are designed.
- **Storing the stump grinder.** When the stump grinder is not in use, store it in a dry, secure place or keep it well-covered and out of the reach of children. Inspect the stump grinder for good working condition prior to storage and before each use.
- **Maintain the stump grinder.** It is recommended that the general condition of the stump grinder be examined before it is used. Keep your machine in good working order by adopting a program of conscientious repair and maintenance in accordance with the recommended procedures found in this manual. If any abnormal vibrations or noise occurs, turn the machine off immediately and have the problem corrected before further use.
- **Cleaning.** Use a pressure washer to clean the carbide teeth while taking care not to pressure-wash the bearings as this could introduce water into areas of the stump grinder that may cause malfunction or damage.
- **Use only accessories that are recommended** by the manufacturer. Accessories that may be suitable for another machine may create a risk of injury when used on this stump grinder.
- **Always** operate the stump grinder with all safety devices and guards in place and in good working order. DO NOT modify or make changes to safety devices. DO NOT operate the stump grinder if any safety devices or guards are missing or inoperative.
- **Never leave the stump grinder running unattended.**
- **Never use the machine to grind anything other than stumps** or for any purpose other than grinding stumps as described in this manual.

# ASSEMBLY

## 1. DEFLECTOR

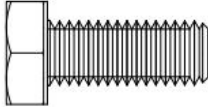
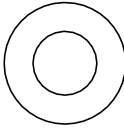
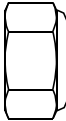
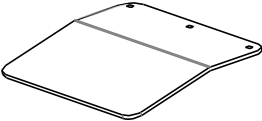

Using the hardware listed below and two (2) 13 mm sockets/wrenches, assemble the deflector (#25) to the flywheel housing as shown.

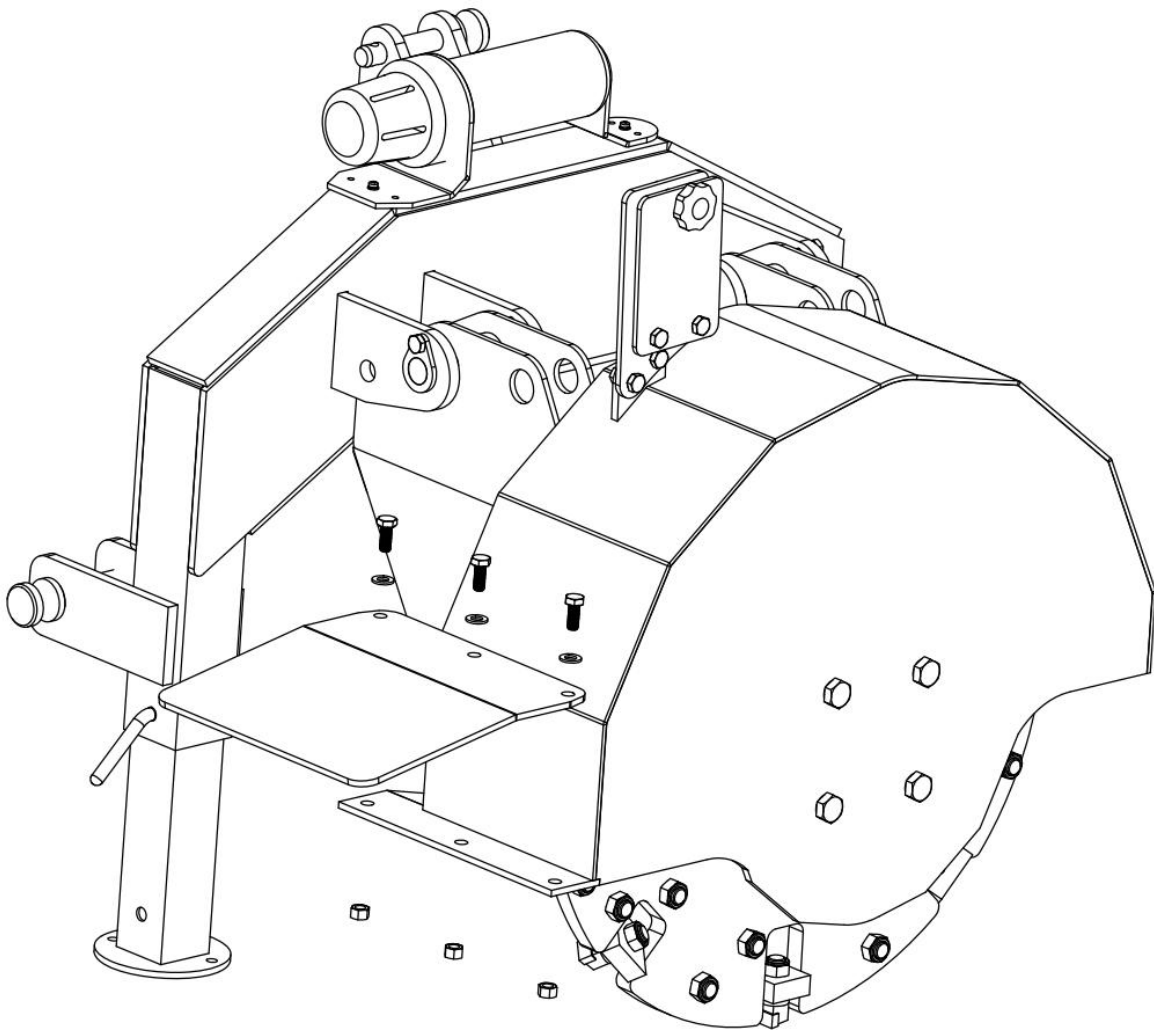
3x	M10 X 35 mm Hex Bolt #39		3x	M10 Flat Washer #47	
3x	M10 Lock Nut #52		1x	Deflector #25	

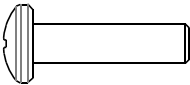

## 2. MANUAL TUBE

Using the hardware listed below and a No. 3 Phillips head screwdriver, assemble the manual tube (#46) to the back frame as shown. Remove the cap from the manual tube (#46) to gain access to the center mounting hole.

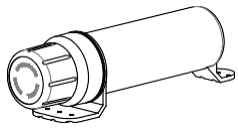
2x	M6 X 20 mm Phillips Pan Head Screw #50		2x	M6 Flat Washer #48	
2x	M6 Split Lock Washer #49		1x	Manual Tube #46	

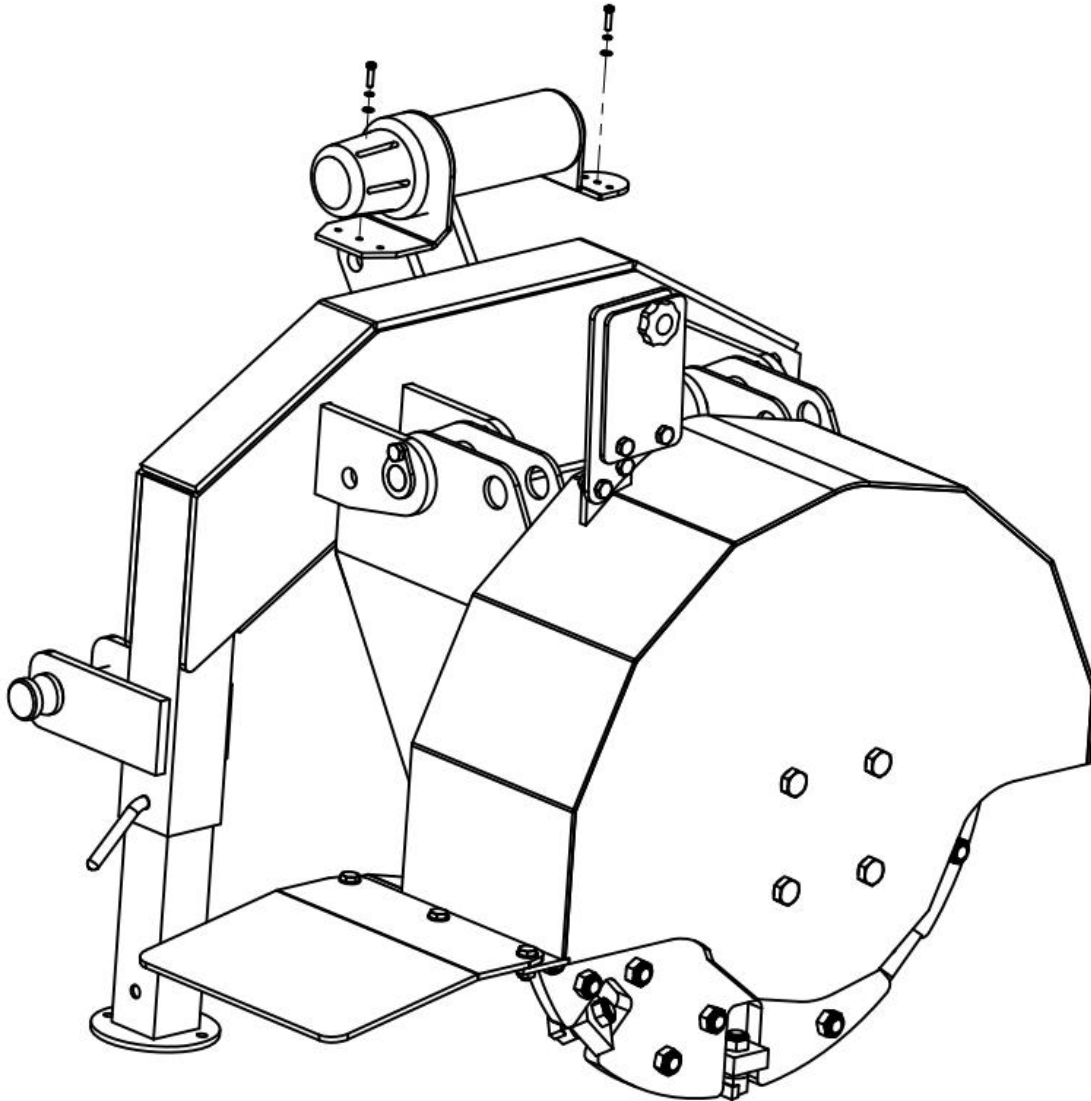

# SET-UP PROCEDURES

## TRIMMING THE PTO SHAFT

The stump grinder is shipped with a slip clutch PTO shaft that can be fitted to most Category 1 tractors. The PTO shaft may need to be trimmed depending on your tractor and configuration. Follow the steps below to ensure the PTO shaft is correctly fitted to your tractor.

**\*\*Note: the slip clutch end of the PTO shaft mounts to the stump grinder.\*\***

1. Attach the stump grinder to the tractor's 3-point hitch system. Do not install the PTO shaft.
2. Raise the stump grinder so that the shaft on the tractor is in line with the shaft on the stump grinder.
3. Measure the distance between the locking grooves on the splined shafts of the tractor and stump grinder (**Dim A**) as shown below:

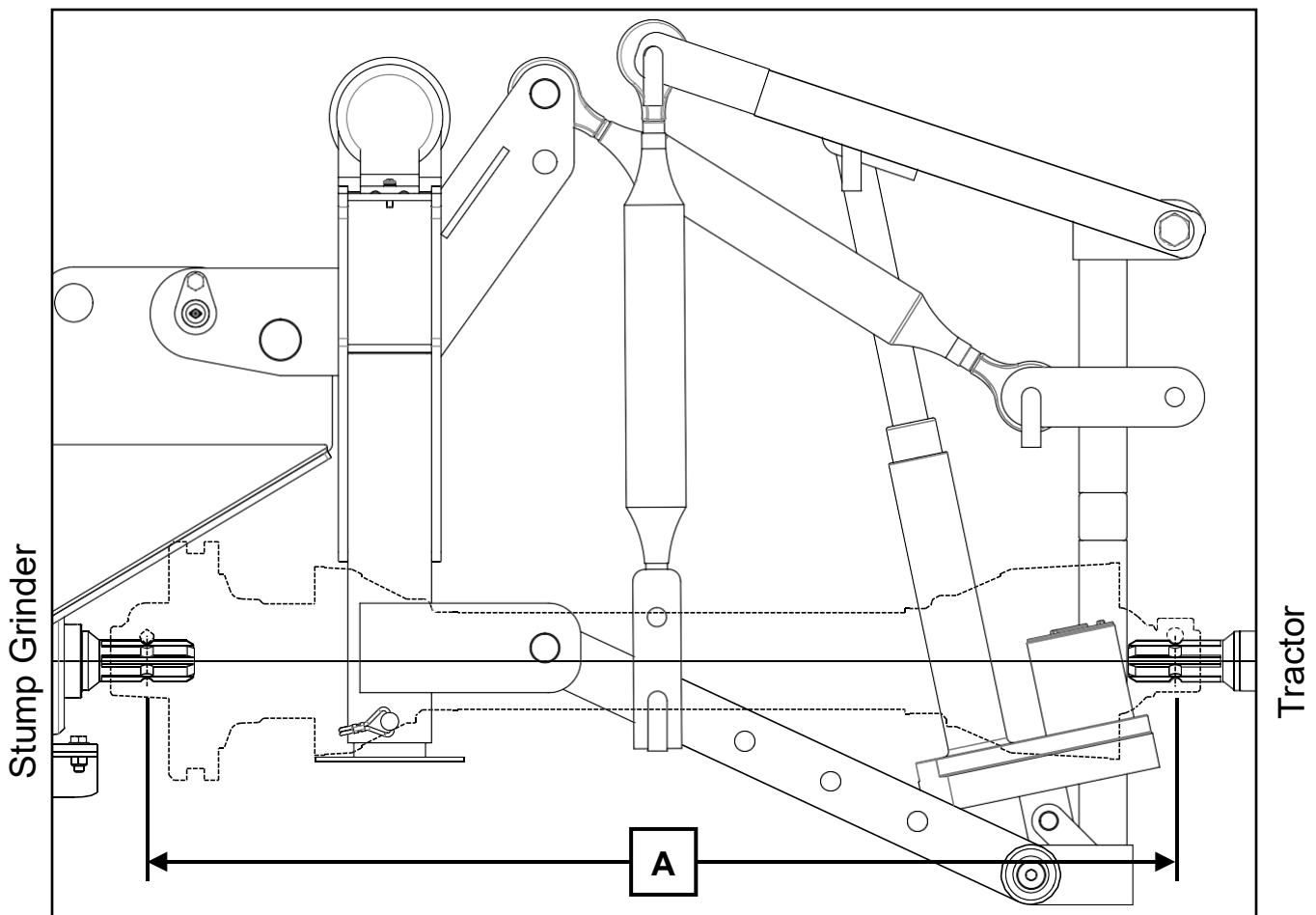

4. Verify the distance between the locking pins on the PTO shaft while in the compressed state (**Dim B**) as shown in the image below. It should measure 34" (862.5 mm).

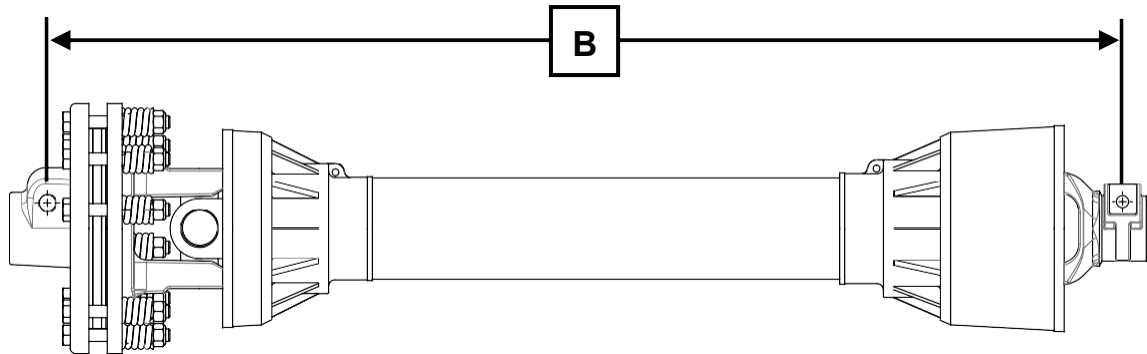

5. If **Dim A** is at least 1" (25 mm) longer than **Dim B**, the PTO shaft does not require trimming. It is recommended the shaft not be used if there is less than 6" (150 mm) of overlap between the two halves of the PTO shaft when the equipment is in the operating position.
6. If **Dim B** is longer than **Dim A**, the PTO shaft will require trimming. Use this equation to calculate the correct amount to trim:

$$(B - A) + 1 \text{ inch} = C \text{ (Amount to Trim)}$$

7. Once **C** has been calculated, trim that amount from **BOTH** halves of the PTO shaft safety cover *first*, then trim the same amount from both shafts. This will ensure the safety cover on each end remains a few inches back from the ends of the shafts, otherwise PTO shaft reassembly could be difficult.
8. After trimming both halves of the PTO shaft, use a file to remove any burrs or sharp edges and slide the halves back together, ensuring they telescope in-and-out freely. The PTO shaft is now ready to connect the stump grinder to the tractor for operation.

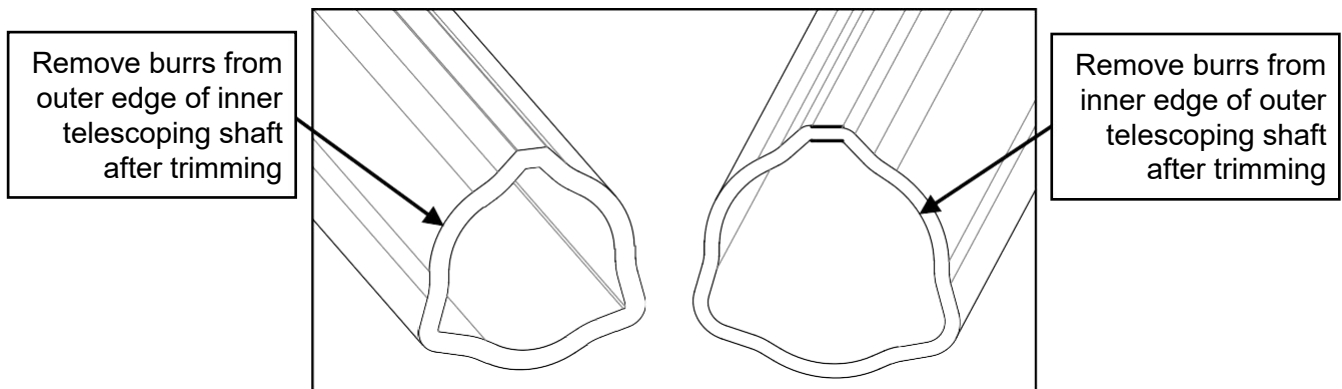

## PTO SHAFT CLUTCH RUN-IN

The stump grinder is shipped with a slip clutch PTO shaft. Follow the steps below before using your stump grinder to ensure the PTO shaft clutch plates are set properly.

1. Connect the PTO shaft to the stump grinder and tractor with the clutch end of the PTO shaft mounted to the stump grinder. Insert the locking pin on the clutch yoke and tighten the nut using a 17 mm wrench or socket.
2. Using a coloured pencil or marker, scribe a line across the exposed edges of the clutch plates.
3. Using a 16 mm wrench or socket, loosen all 8 spring tension nuts uniformly until the ends of the nuts are flush with the ends of the bolts (**Fig. A**).

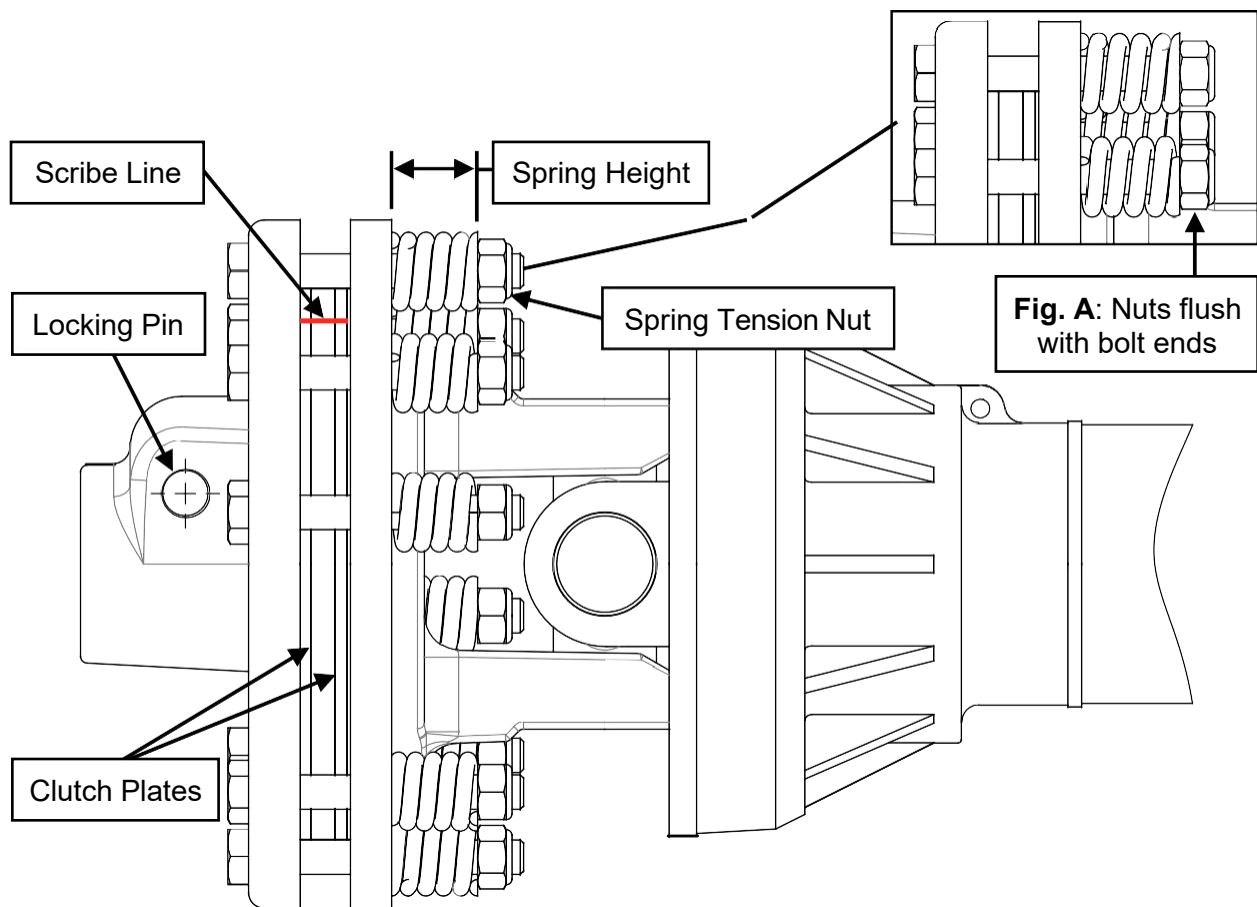

4. Start the tractor and engage the PTO for 2-3 seconds to permit slippage of clutch surfaces. Disengage the PTO then re-engage a second time for 2-3 seconds. Disengage the PTO again, shut off the tractor, and remove the key. Wait for all components to stop rotating before removing the PTO shaft from tractor.
5. Inspect the clutch and ensure that the scribed markings made across the clutch plates have changed position. Slippage has not occurred if the two marks on the clutch plates are still aligned. A clutch that has not slipped must be disassembled to separate the clutch plates.

- Tighten all 8 nuts until the proper spring height dimension values are achieved per the “*PTO Shaft Clutch Spring Height vs. Horsepower*” table for your PTO output horsepower. It is recommended that a calliper (either digital, dial, or vernier—similar to the one shown below) be used to accurately verify the spring height measurements. After setting all 8 spring heights, the clutch is now ready for use.

### PTO Shaft Clutch Spring Height vs. Horsepower

PTO Shaft	Clutch Flange Dia	PTO hp	Spring Height
5S.FF2	7- <sup>5</sup> / <sub>8</sub> " (200 mm)	20 hp	1.26" (31.9 mm)
		25 hp	1.25" (31.7 mm)
		30 hp	1.24" (31.4 mm)
		35 hp	1.22" (31.1 mm)
		45 hp	1.20" (30.5 mm)

All ratings are at 540 rpm PTO speed

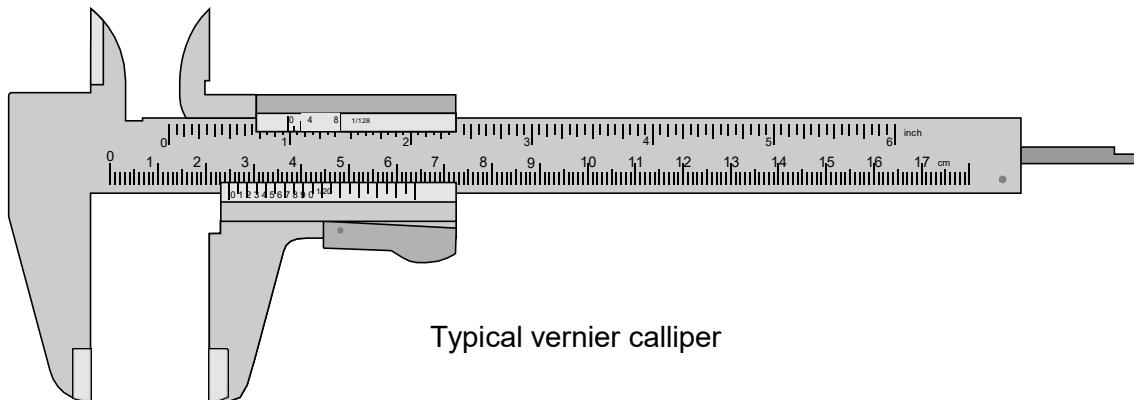

- The clutch should be checked during the first hour of use and periodically each week thereafter. Excessive clutch plate slippage, burning odor, or visible smoking should not be observed during use.

# FLYWHEEL TOOTH TORQUING

Prior to operation, ensure all 34 teeth (#18) are torqued to 160 ft•lb (215 N•m) using a torque wrench with a 24 mm socket.

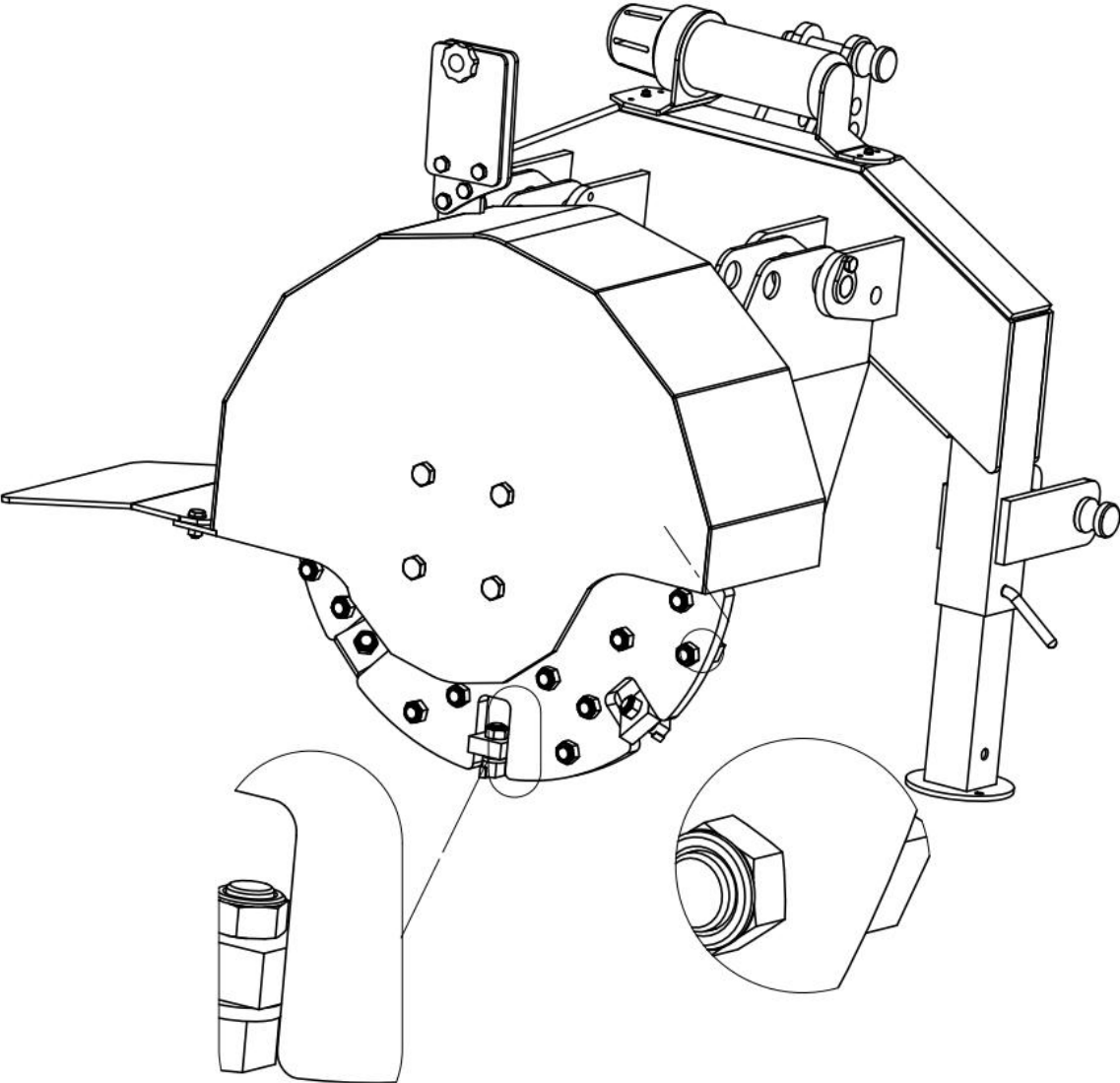



## EQUIPMENT OPERATION



### WARNING!

To avoid death or serious injury, do not grind stumps containing embedded foreign objects such as nails, wire, metal fragments, etc.

1. Wear heavy-duty work gloves, ANSI-approved goggles behind a full face shield, steel-toed work boots, and a dust mask.
2. Securely attach the stump grinder to the tractor's 3-point hitch system and install the PTO shaft.
3. Prior to each daily use, check all 34 teeth (#18) and ensure they are not loose, missing, or damaged, and are torqued to the proper specification. Torque any undamaged loose teeth to 160 ft•lb (215 N•m) using a torque wrench with a 24 mm socket.

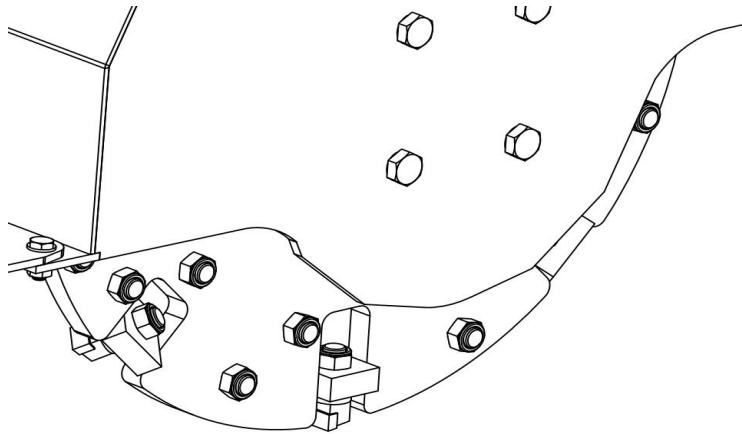

4. Remove the stabilizer pin (# 51) prior to operation as shown below:

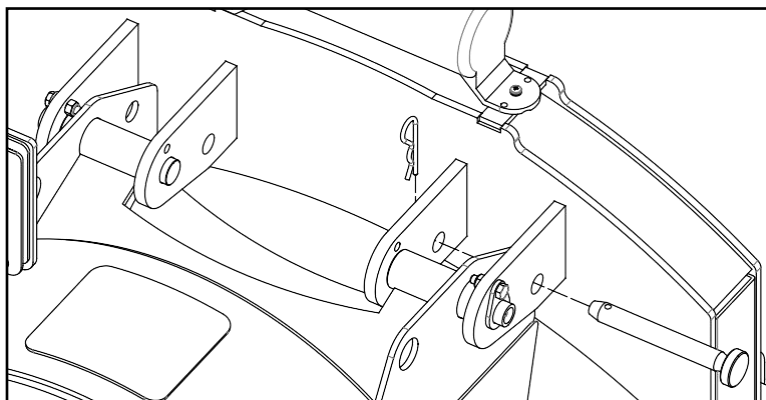

5. Remove the leg locking pins (#37), slide the legs (#13) up inside the tubes of the back frame (#15), and reinstall the locking pins (#37) to secure them in place.

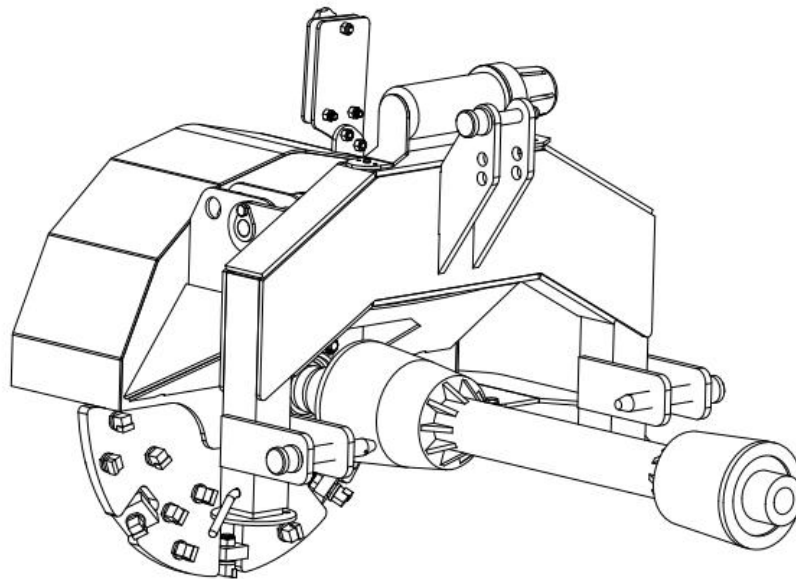
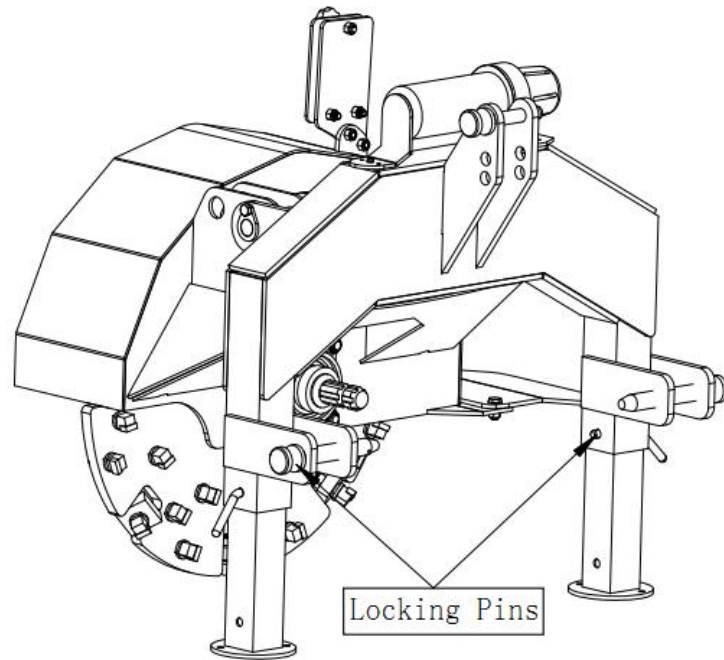

6. Reverse over a tree stump and lower the stump grinder so it will remove 2" (50 mm) per pass. Always ensure the grinder is cutting properly and not jumping around erratically. Read pages 20-21 on proper stump grinding procedures.

7. Once the stump is at ground level, continue to take up to 2" (50 mm) deep passes until the stump and roots are 4-6" (100-150 mm) below grade. Keep a watch out for foreign objects below the soil like rocks or buried metal. These can damage or break the teeth resulting in poor grinding performance.
8. During use, it is important to never let the stump grinder sway beyond an angle that will allow the PTO shaft to separate. Do not operate the stump grinder with less than 6" (150 mm) of overlap between the two halves of the PTO shaft. If the stump grinder begins to sway, it means either the tractor is advancing faster than the grinder can remove material or that too much material is being removed per pass. If this is observed, immediately stop moving forward and position the tractor and stump grinder in a manner so that it is in the vertical position. Take a slower pass and/or shallower cut if necessary.

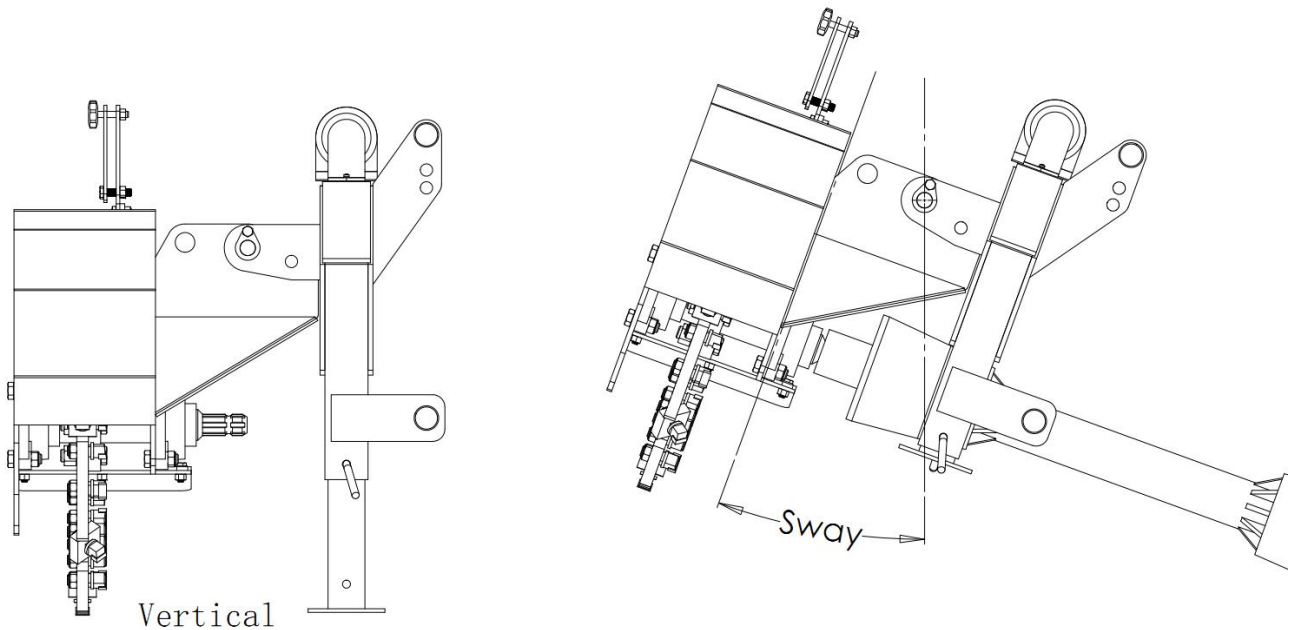

# STUMP GRINDING PROCEDURE

The flywheel spins in a clockwise manner (when facing the rear of the machine) with the effective cutting area in the lower-left quadrant as shown below:

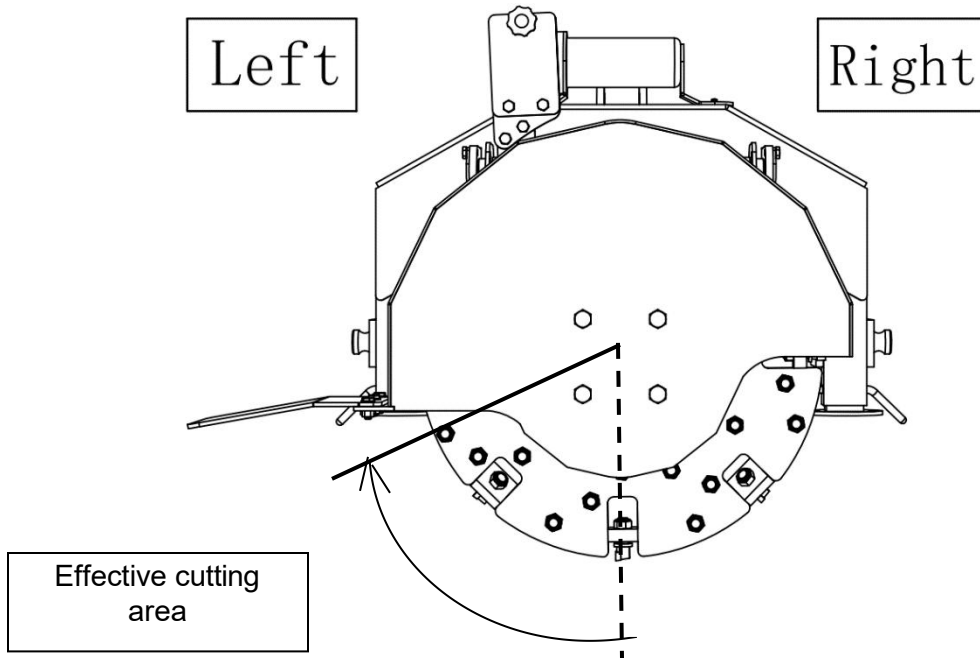

Therefore, when grinding a tree stump, always start from the right side of the stump, moving incrementally to the left, pulling the grinder straight forward through the stump on each pass. When grinding softwoods like pine, spruce, or poplar, it may be permissible to remove upwards of 2" (50 mm) of material per pass. However, hardwoods like oak, ash, and birch can be much more dense and the depth of grind may only be up to 1" (25 mm). If the chassis is swaying like described in the previous section, or the grinder is vibrating or bouncing, reduce the depth of cut or feed rate accordingly.

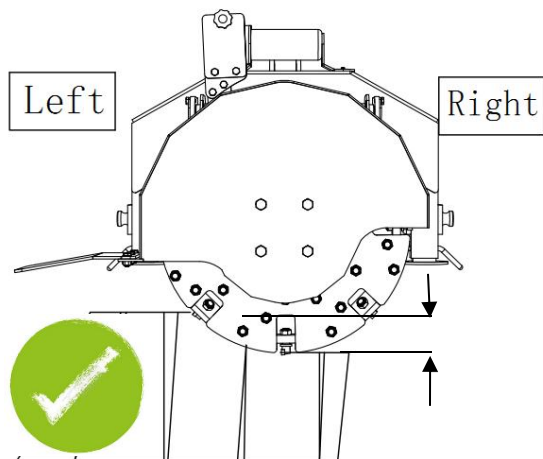

Depth of Grind

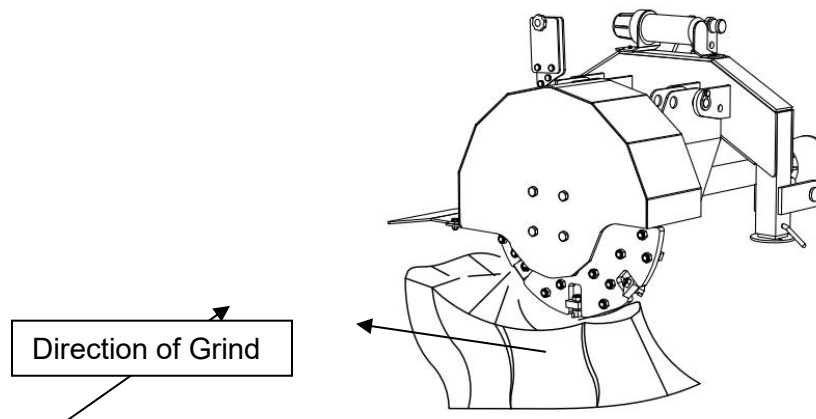

Grind Progression

# INCORRECT GRINDING PROCEDURES

It is critical that the stump grinder is never pulled through the center of a stump or ground from left-to-right. This will induce severe vibration and cause the grinder to sway and bounce. It may also damage the machine and/or break teeth. Follow the directions on the previous page to ensure efficient and safe grinding.

## PULLING THROUGH THE CENTER

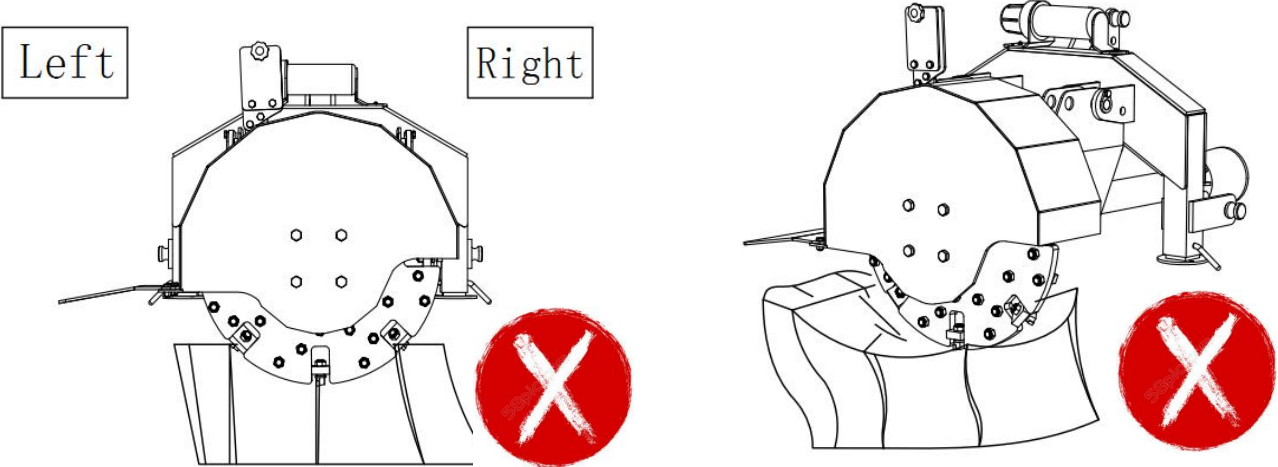

## GRINDING LEFT-TO-RIGHT

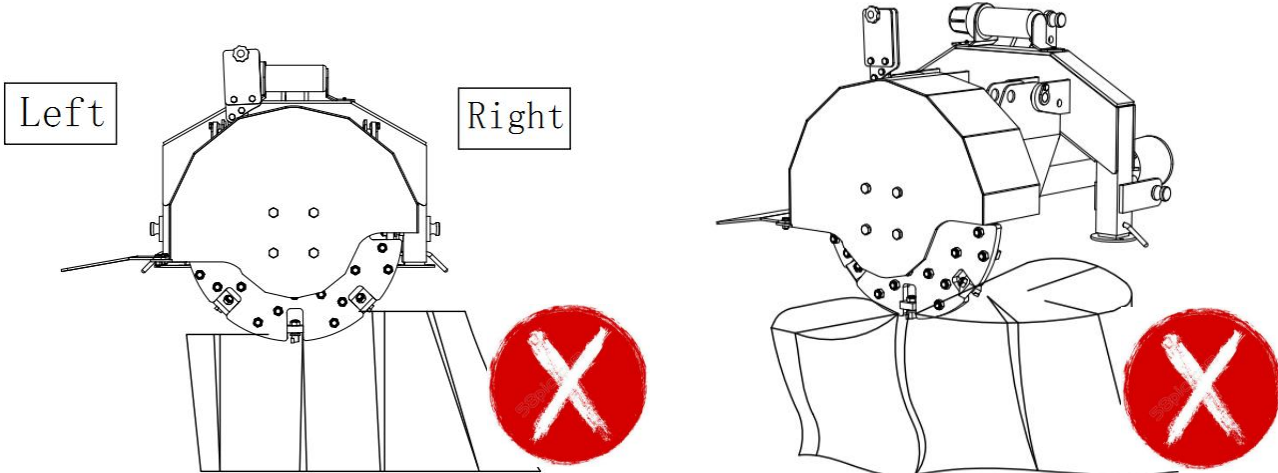

## CHAINSAW HOLDER

Use the chainsaw holder (#38) only during transport. Always remove the chainsaw from the holder prior to grinding stumps.

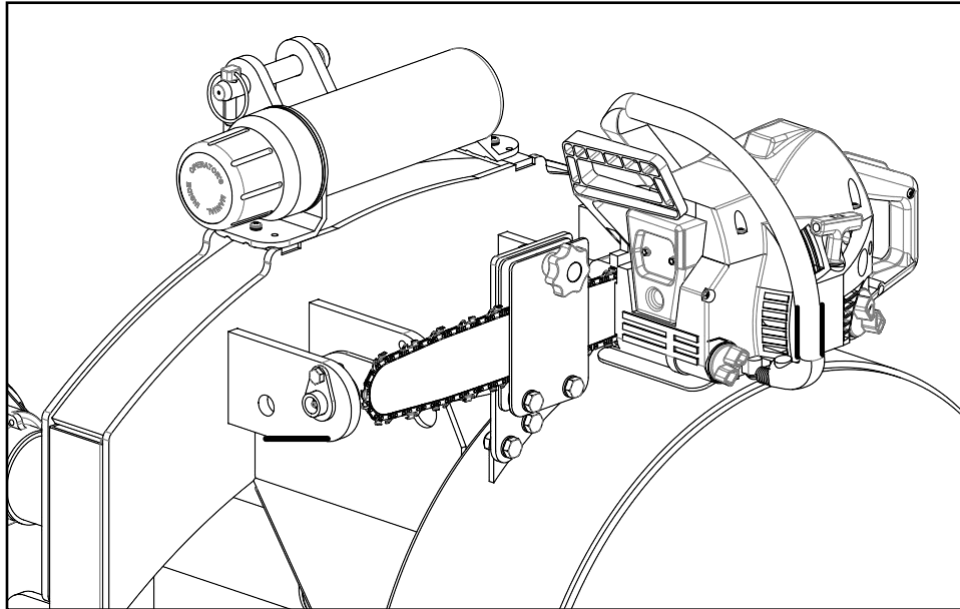

## STORAGE

1. Lower both support legs (#13) and reinsert the locking pins (#37).
2. Insert the stabilizer pin (#51) in either the left or right side of machine. It does not matter which side is selected.
3. Lower the stump grinder onto a flat, level surface.
4. Disconnect the PTO shaft (#34).
5. Remove the stump grinder from the tractor's 3-point hitch system.

## MAINTENANCE

- Proper routine maintenance is critical to operator safety, achieving proper stump grinding results, and prolonging the life of the machine.
- Before cleaning and/or any maintenance is performed on the stump grinder, always turn off the tractor engine and disconnect the PTO shaft.
- Inspect the machine before each use for loose nuts and worn cutting teeth and clean any debris that has built-up.
- After 2 hours of operation, check for loose nuts and worn cutting teeth. Tighten and replace as necessary.
- Grease the bearings and the pivot pins (#3) on the main housing as needed before each use. Do not over-grease the bearings as this can blow out the seals and cause premature bearing failure.
- Inspect the clutch plates on the PTO shaft periodically to ensure that they are not seized together. Refer to **PTO Shaft Clutch Run In** in the **Set Up Procedures** section of the manual.

## REPLACING TEETH

1. Disconnect the PTO shaft from the tractor and set the stump grinder on a flat, level surface.
2. Remove the M16x1.5 lock nut (#19) (fine thread) from the back of the tooth using a 24 mm wrench or socket.
3. Remove the worn cutting tooth while noting its orientation so that the replacement tooth will be installed in the same manner.

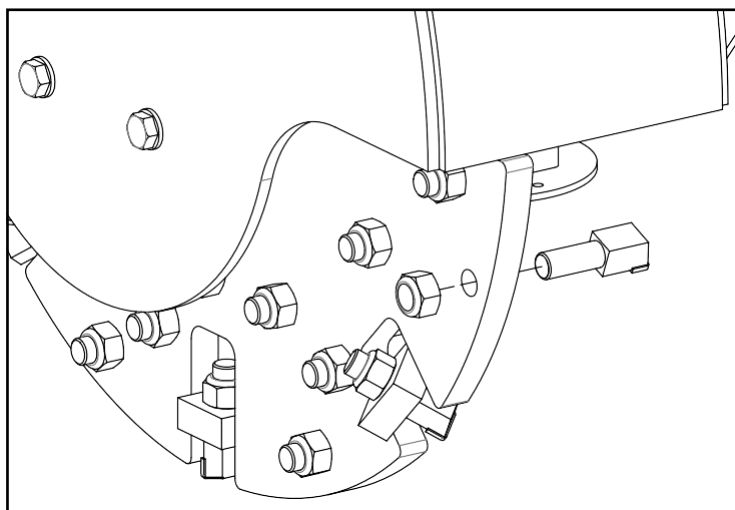

4. Install the replacement tooth (#18) and lock nut (#19) using a torque wrench set to 160 ft•lb (215 N•m). Refer to section **Flywheel Tooth Torquing** for more detail.

# DIAGRAM & PARTS LIST

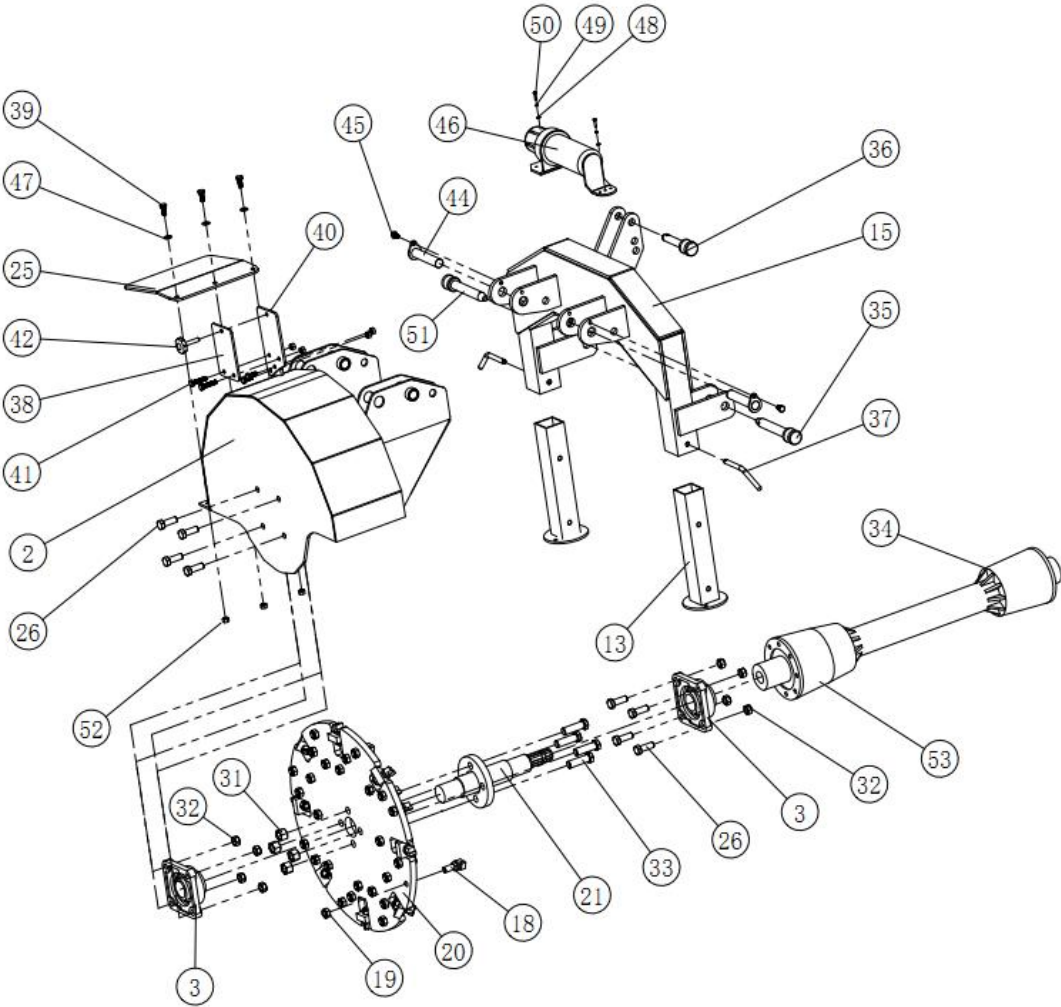



Part #.	Description	Qty.
2	Flywheel housing	1
3	Flange bearing	1
13	Support legs	2
15	Back frame	1
18	Flywheel teeth	34
19	Flywheel teeth nut	34
20	Flywheel	1
21	Flywheel shaft	1
25	Deflector	1
26	Hex bolt M16x50	8
31	Flywheel nut M16	4
32	Tooth nut M16	8
33	Flywheel bolt M16x60	4
34	PTO shaft	1
35	3-point hitch pin single $\phi$ 22	2
36	3-point hitch pin single $\phi$ 19	1
37	Locking pin single $\phi$ 12	2
38	Chainsaw holder clamping plate	1
39	Hex bolt M10X35	3
40	Chainsaw holder mounting plate	1
41	Hex bolt M10x25, Hex bolt M10x45	2, 2
42	Knob, Multi-lobe	1
44	Frame connect pin $\phi$ 25	2
45	Hex bolt M6x20	2
46	Manual tube	1
47	Flat pad $\phi$ 10, Spring pad $\phi$ 10	3, 3
48	Flat pad $\phi$ 16	3
49	Split lock pad $\phi$ 16	3
50	Bolt M6X16	3
51	Stabilizer pin $\phi$ 19	1
52	Nut M10	3
53	Clutch	1

**This item is not returnable.**

For replacement parts and technical questions, please call **1-218-943-6290**.

## **WARRANTY**

**One-year limited parts warranty.**



BAC  
 PO BOX 155  
 Miliona, MN 56354  
 Made in China  
 Page 25 of 26

