



---

# USER'S GUIDE

**Smart Portable Audio Monitor and Soother  
With Night Light and Bluetooth Speaker**

**Eclipse+**

The Features described in this user's guide are subject to modifications without prior notice.

# Welcome...

## to your new smart Wi-Fi Audio Monitor and Soother!

Thank you for purchasing your new Hubble Nursery product. This Smart Wi-Fi Audio Monitor and Soother create a calm and relaxing nursery ambience, in various ways, helping your baby sleep peacefully and you can hear his (her) sleeping in another room.

Connect your phone via Bluetooth and play a lullaby or audiobook for your little one, on the high-quality speaker.

Choose from 7 different night light colors to soothe your baby, in the dark. The night light also provides guidance, during late night feeding and diaper changes, without having to turn on the harsh, aggressive bedroom lights.

Please retain your original dated sales receipt for your records. For warranty service of your Hubble product, you will need to provide a copy of your dated sales receipt to confirm warranty status. Registration is not required for warranty coverage.

For product related questions, please contact:

**Live Chat: [hubbleconnected.com](https://hubbleconnected.com)**

**Email: [support@hubbleconnected.com](mailto:support@hubbleconnected.com)**

**<https://hubbleconnected.com/warranty>**

**<https://hubbleconnected.com/apps/product-registration>**

---

Visit **[support.hubbleconnected.com](https://support.hubbleconnected.com)** to download the User Guide with instructions, answers to frequently asked questions, and more to help you get the most from your product.

## Inside the Box

- 1 x Eclipse+ (Smart Wi-Fi Audio Monitor and Soother)
- 1 x USB Charging Cable (Type-C)
- 1 x Quick Start Guide

# Overview of Eclipse+

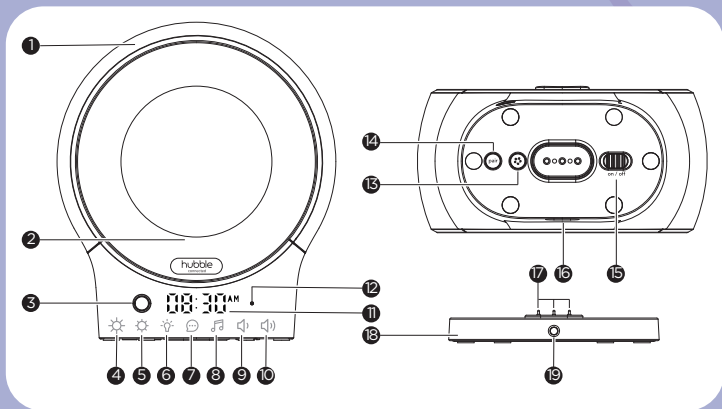

1. Night Light
2. Speaker
3. Light Sensor
4. Brightness Up key
5. Brightness Down key
6. Night Light key
7. ConnectChat™ key
8. Soothing Sound key
9. Volume Down key
10. Volume Up key
11. Digital Clock
12. Microphone
13. Hubble Pair button
14. Bluetooth Pair button
15. Power On/Off switch
16. Power Socket
17. Charging PINs
18. Charger Pod
19. USB Charging Cable

## Important guidelines for installing your Eclipse+

- Use of other 2.4 GHz products, such as other wireless networks, Bluetooth® systems or microwave ovens may cause interference with this product. Keep the Unit away from these types of products, or turn them off if they appear to be causing interference.
- Always ensure that you have a good Wi-Fi® connection available.

## Table of contents

---

1. Safety Instructions .....	5
2. System Requirements of Smart Device .....	6
3. Getting Start .....	7
3.1 Charge Eclipse+ .....	7
3.2 Power on Eclipse+ .....	7
3.3 Connect to HubbleClub .....	7
4. Basic Operation of Eclipse+ .....	8
4.1 Control Night Light .....	8
4.2 Control Soothing Sound .....	8
4.3 Use Eclipse+ as a Bluetooth Speaker .....	8
4.4 Use ConnectChat™ .....	9
5. Disposal of the Device (environment) .....	10
6. Troubleshooting .....	10
7. General Information .....	11
8. Technical Specifications .....	16



## 1. Safety Instructions

 **WARNING:**

**Strangulation Hazard: Children have STRANGLED on cords. Keep this cord out of the reach of children (more than 3ft (1m) away).**

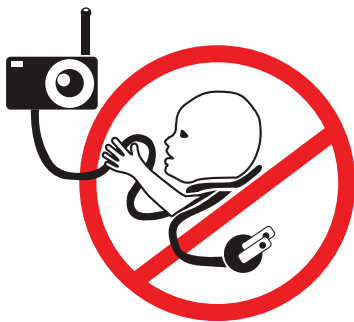

## WARNING

This product is compliant with all relevant electromagnetic field standards and is, when handled as described in the User's Guide, safe to use. Therefore, always read the instructions in this User's Guide carefully before using the device. Understand and follow all instructions and warnings including:

- Adult assembly is required. Keep small parts away from children when assembling.
- The device is intended for indoor use only. Do not operate it outdoors.
- Place the device on a smooth, level, waterproof surface that is elevated off the ground.
- Do not install it directly next to a wall or near electrical devices.
- Always handle the device with dry hands to avoid electric shocks.
- Do not operate the device with a damaged cord or plug.
- Unplug the device when not in use.
- Keep the cords out of reach of children.
- Test this device and all its functions so that you are familiar with it prior to actual use.
- Keep this user's guide for future reference.

## 2. System Requirements of Smart Device

Smartphones/Tablets: Android™ and iOS® only.

Minimum System Requirement: iOS 12.0, Android 8.0, Bluetooth 4.2.



## 3. Getting Start

### 3.1 Charge Eclipse+

- Connect the charging cradle with a 5V 2A power adaptor (not included.)
- Put Eclipse+ on the charging cradle.

### 3.2 Power on Eclipse+

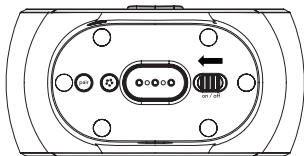

Slide the Power Switch to switch on Eclipse+. The Night Light, Digital Clock and backlight of touch key turn on.

### 3.3 Connect to HubbleClub





- Scan the QR code with your smart device and download HubbleClub by Hubble Connected App from the App Store for iOS devices or from the Google Play™ Store for Android™ devices.
- Install HubbleClub by Hubble Connected App on your device.
- Press and hold Hubble Pair (🔄) button at the bottom of Eclipse+.
- The LED indicator blinks in red and blue alternatively for 180 s at pairing mode.
- Follow the instructions of HubbleClub App to create your HubbleClub account.
- Select **Wellness** and then **Eclipse+**, follow the in-app instructions to connect Hubble Eclipse+ to your account.





- If registration fails or connection cannot be completed during 180 s, connection mode will be turned off. Pairing LED Indicator will turn red.
- If registration fails, please try again by going through Step 1 to Step 4.
- Full control and full features can be accessed with HubbleClub App.

## 4. Basic Operation of Eclipse+

### 4.1 Control Night Light

- Tap Night Light  icon at the front of Eclipse+ will change the colour of night light. The colour changes in cycle.
- The brightness of night light can be adjusted by tap brightness up  and brightness down  icons.

### 4.2 Control Soothing Sound

- Tap Soothing Sound  icon at the front of Eclipse+ will change the soothing sound.
- The volume of the soothing sound can be adjusted by tap volume up  and volume down  icons.

### 4.3 Use Eclipse+ as a Bluetooth Speaker

- Press and hold Bluetooth Pair  button at the bottom of Eclipse+ to enter into pairing mode. The LED will blink in blue.
- Go to the Set-Up menu of your mobile phone. Then go to Bluetooth Connection.
- Find the Device name "Hubble Eclipse+" and connect.
- If the connection fails, please try again by going through steps 1 to 3.
- Stream the audio from your mobile phone and listen to it in Eclipse+.

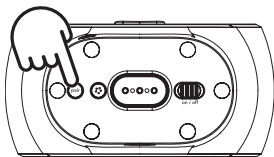

#### **Note:**



Once Bluetooth is disconnected, reactive Bluetooth by long pressing Bluetooth Pair  button, and reconnect Eclipse+ on your mobile phone.





#### 4.4 Use ConnectChat™

Ensure the mobile and Eclipse+ are online under the same network.

- Press the  icon to start chatting with the mobile phone with Eclipse+ App turned on.
- If the Eclipse+ App is not on, pressing the  icon will send a notification to the App.
- During notification, a ring-back tone can be heard.
- The ring-back tone will be turned off when the ConnectChat™ function is activated on the App. The notification and ring-back tone will time out in 15 seconds.



## 5. Disposal of the Device (environment)

At the end of the product life cycle, you should not dispose of this product with normal household waste. Take this product to a collection point for the recycling of electrical and electronic equipment. The symbol on the product, user's guide and/or box indicates this.



Some of the product materials can be re-used if you take them to a recycling point. By reusing some parts or raw materials from used products you make an important contribution to the protection of the environment.

Please contact your local authorities in case you need more information on the collection points in your area.

## 6. Troubleshooting

(To be advised)



## 7. General Information

If your product is not working properly, read this Quick Start Guide or the online User's Guide of one of the models listed on page 1.

For questions, warranty, support or service related the product, please contact us by:

**Live Chat:** [hubbleconnected.com](https://hubbleconnected.com)

**Email:** [support@hubbleconnected.com](mailto:support@hubbleconnected.com)

**Online warranty registration:** <https://hubbleconnected.com/warranty>

**Online Product Registration:** <https://hubbleconnected.com/apps/product-registration>

### Consumer Products and Accessories Limited Warranty ("Warranty")

Thank you for purchasing this Hubble Smart Nursery branded product manufactured under license by Hubble Baby (HK) Limited ("HUBBLE").

#### What Does this Limited Warranty Cover?

Subject to the items listed below in the section "What is not Covered" HUBBLE warrants that this Hubble connected branded product ("Product") will be free from defects in material and workmanship under normal use for a period of 1 year from the date of purchase and that any certified accessory ("Accessory") sold for use with this product will be free from defects in materials and workmanship under normal use for a period of 90-days from the date of purchase. This Limited Warranty is your exclusive warranty and is not transferable.

#### What is not covered?

This Limited Warranty excludes and does not cover:

- Normal deterioration or wear resulting from use;
- Damage caused by or resulting from misuse, abuse, or accident;
- Damage caused by or resulting from improper operation or storage;
- Damage caused by or resulting from contact with foreign substances, including, but not limited, to liquid, water, rain, humidity, perspiration, sand, dirt, and/or food;
- Damage caused by or resulting from the use of Non-Hubble Smart Nursery branded or certified Products or Accessories or other peripheral equipment;



- Damage caused by or resulting from modifications, alterations, tampering, improper installation, or repairs by someone other than Hubble connected, HUBBLE or their authorized representatives;
- Defects, damages, or the failure of Products or Accessories due to any communication service or signal you may subscribe to or use with the Products or Accessories; and,
- Periodic maintenance, repair and replacement of parts due to normal wear and tear.

### **What Other Limitations Are There?**

THIS LIMITED WARRANTY SETS FORTH THE ENTIRE LIABILITY OF HUBBLE AND CONTAINS YOUR SOLE AND EXCLUSIVE REMEDY. OTHER THAN THIS LIMITED WARRANTY, HUBBLE MAKES NO ADDITIONAL REPRESENTATIONS OR WARRANTIES, EXPRESS OR IMPLIED, INCLUDING WARRANTIES OF MERCHANTABILITY OR FITNESS FOR A PARTICULAR PURPOSE. IF YOUR STATE DOES NOT PERMIT THE DISCLAIMER OF WARRANTIES, THEN THE IMPLIED WARRANTY OF MERCHANTABILITY AND FITNESS FOR A PARTICULAR PURPOSE IS LIMITED TO THE DURATION OF THIS LIMITED WARRANTY. REPAIR OR REPLACEMENT IS YOUR SOLE AND EXCLUSIVE REMEDY AGAINST HUBBLE AND Hubble Smart Nursery. IN NO EVENT SHALL HUBBLE OR Hubble Smart Nursery's LIABILITY TO REPAIR OR REPLACE YOUR PRODUCT OR ACCESSORY EXCEED THE ORIGINAL PURCHASE PRICE OF THE PRODUCT AND ACCESSORY AND HUBBLE AND Hubble Smart Nursery's TOTAL LIABILITY FOR DAMAGES ARISING FROM THIS LIMITED WARRANTY SHALL NOT EXCEED THE PRICE YOU PAID FOR THE PRODUCT AND ACCESSORY REGARDLESS OF WHETHER SUCH CLAIM ARISES UNDER CONTRACT, STATUTE, TORT OR OTHERWISE. IN NO EVENT AND UNDER NO CIRCUMSTANCES WILL HUBBLE OR Hubble Smart Nursery BE LIABLE FOR DIRECT, INDIRECT, INCIDENTAL, SPECIAL OR CONSEQUENTIAL DAMAGES OF ANY KIND, OR LOSS OF REVENUE OR PROFITS, LOSS OF BUSINESS, LOSS OF INFORMATION OR OTHER FINANCIAL LOSS ARISING OUT OF OR IN CONNECTION WITH THE ABILITY OR INABILITY TO USE THE PRODUCTS OR ACCESSORIES. ALL DISCLAIMERS, LIMITATIONS OF LIABILITY AND MODIFICATIONS OF WARRANTIES STILL APPLY EVEN IF THE LIMITED REMEDY OF REPAIR AND REPLACEMENT FAILS OF ITS ESSENTIAL PURPOSE.



Some jurisdictions do not allow the limitation or exclusion of incidental or consequential damages, so the above limitations or exclusions may not apply to you. This Limited Warranty gives you specific legal rights, and you may have other rights that vary from one jurisdiction to another.

## Who is covered?

This Warranty extends only to the first consumer purchaser and is not transferable.

## What will HUBBLE do?

HUBBLE or its authorized distributor at its sole discretion will, at no charge, repair or replace any Products or Accessories that do conform to this Warranty. In the event that replacement is necessary to remedy a defect in material or workmanship, HUBBLE may use new or remanufactured products, accessories or parts of equal quality to the original Product or Accessory.

## How to Obtain Warranty Service or Other Information?

For questions, warranty, support or service related the product, please contact us by:

**Live Chat:** [hubbleconnected.com](https://hubbleconnected.com)

**Email:** [support@hubbleconnected.com](mailto:support@hubbleconnected.com)

**Online warranty registration:** <https://hubbleconnected.com/warranty>

**Online Product Registration:** <https://hubbleconnected.com/apps/product-registration>

You will receive instructions on how to ship the Products or Accessories at your expense and risk, to a HUBBLE Authorized Repair Center.

You must include: (a) the Product or Accessory; (b) the original proof of purchase (receipt) which includes the date, place and seller of the Product; (c) if a warranty card was included in your box, a completed warranty card showing the serial number of the Product; (d) a written description of the problem; and, (e) your name, address, email address and telephone number. These terms and conditions constitute the complete warranty agreement between you and HUBBLE regarding the Products or Accessories purchased by you, and supersede any prior agreement or representations, including representations made in any literature publications or promotional materials issued by HUBBLE or representations made by any agent, employee or staff of HUBBLE, that may have been made in connection with your purchase of any Product and/or Accessory.



## FCC and IC regulations

### FCC Part 15

NOTE: This equipment has been tested and found to comply with the limits for a Class B digital device, pursuant to Part 15 of the Federal Communications Commission (FCC) rules. These limits are designed to provide reasonable protection against harmful interference in a residential installation. This equipment generates, uses and can radiate radio frequency energy and, if not installed and used in accordance with the instructions, may cause harmful interference to radio communications. However, there is no guarantee that interference will not occur in a particular installation.

If this equipment does cause harmful interference to radio or television reception, which can be determined by turning the equipment off and on, the user is encouraged to try to correct the interference by one or more of the following measures:

- Reorient or relocate the receiving antenna.
- Increase the separation between the equipment and receiver.
- Connect the equipment into an outlet on a circuit different from that to which the receiver is connected.
- Consult the dealer or an experienced radio/TV technician for help.

This device complies with Part 15 of the FCC Rules. Operation is subject to the following two conditions: (1) this device may not cause harmful interference, and (2) this device must accept any interference received, including interference that may cause undesired operation. Privacy of communications may not be ensured when using this device.

To ensure safety of users, the FCC has established criteria for the amount of radio frequency energy that can be safely absorbed by a user or bystander according to the intended usage of the product. This product has been tested and found to comply with the FCC criteria.



## WARNING

Changes or modifications not expressly approved by the party responsible for compliance could void the user's authority to operate the equipment.

Le présent appareil est conforme aux CNR d'Innovation, Sciences et Développement économique Canada applicables aux appareils radio exempts de licence. L'exploitation est autorisée aux deux conditions suivantes : (1) L'appareil ne doit pas produire de brouillage; (2) L'appareil doit accepter tout brouillage radioélectrique subi, même si le brouillage est susceptible d'en compromettre le fonctionnement.

FCC RF Radiation Exposure Statement Caution: This Transmitter must be installed to provide a separation distance of at least 20cm from all persons.

IC Radiation Déclaration d'exposition Attention: Cet émetteur doit être installé pour fournir une distance de séparation d'au moins 20cm de toute personne.

Download User Guide from website: [support.hubbleconnected.com](https://support.hubbleconnected.com)



## 8. Technical Specifications

Wi-Fi version	802.11 b/g/n, 2.4GHz
Bluetooth Audio	Bluetooth 4.2
Operating Temperature	41 to 104 <sup>0</sup> F (5 to 40 <sup>0</sup> C)
Speaker Type	4 $\Omega$ , 5W
Night Light	RGB, 7 colors, and auto cyclic mode
Volume Control	5 Level
Brightness Control	5 Level







Manufactured, distributed and sold by Hubble Baby (HK) Limited. Apple logo is trademark of Apple Inc., registered in the U.S. and other countries. App Store is a service mark of Apple Inc. Google Play and Android are trademarks of Google Inc. Wi-Fi is a trademark of the Wi-Fi Alliance. All rights reserved.

US\_EN Version 1.0  
Printed in China

