

# **WARNING**

## **TO REDUCE THE RISK OF SERIOUS INJURY OR DEATH:**

- **NEVER** use the tractor in roadways, near cars, on or near steps, swimming pools, or other bodies of water.
- **ALWAYS** wear shoes. **ALWAYS** sit on the seat.
- **NEVER** allow more than one riders at the same time when operating this product . Keep arms and legs inside the vehicle at all times.



## **WARNING:**

- **CHOKING HAZARD!** Not suitable for children under 36 months.
- **Must be assembled by an adult.**



### PREVENT INJURIES AND DEATHS:

- **NEVER LEAVE CHILD UNATTENDED.** ADULT DIRECT SUPERVISION IS REQUIRED. Always keep child in view when child is in vehicle.
- This toy should be used with caution since skill is required to avoid falls or collisions causing injury to the user or third parties.
- Protective equipment should be worn.
- To reduce the risk of injury, adult supervision is required. Never use in roadways, near motor vehicles, on or near steep inclines or steps, swimming pools or other bodies of water, always wear shoes, and never allow more than 2 riders.
- Not to be used in traffic.
- This toy is unsuitable for children under 36 months due to its maximum speed; Maximum user weight is 66 lbs.
- Instructions to be given to the child in the proper use of the toy , particularly in the use of any braking system.

**Best Ride On Cars**

# **BOBCAT FARM TRACTOR 12V USERS MANUAL**

**With Assembly Instructions**

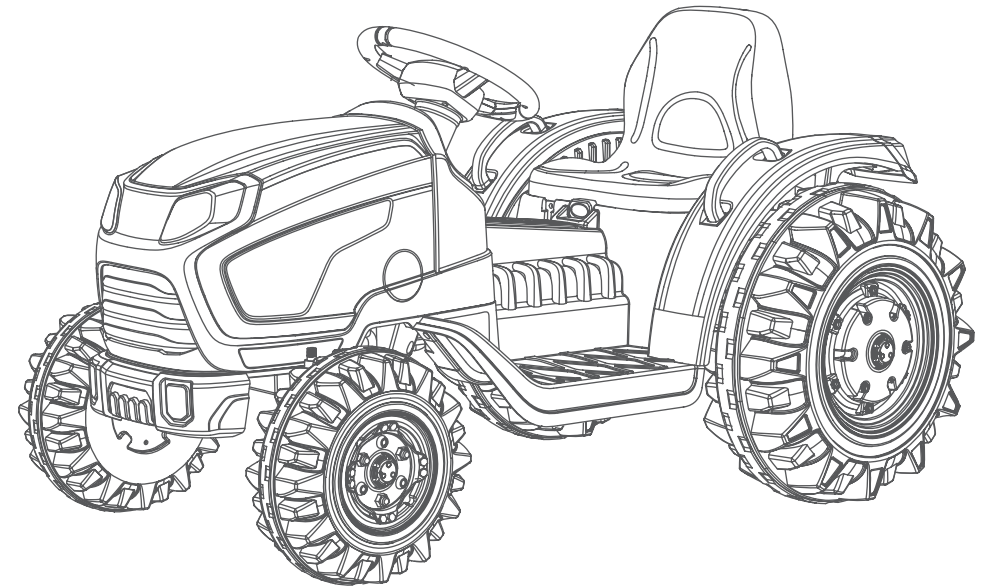

| <b>Important</b>   | <b> WARNING</b>   |
|--|--|
| <b>Age: 3-8 Years<br/>Maximum<br/>User<br/>Weight :66 lbs.</b> | <ol style="list-style-type: none"><li>1. This toy is unsuitable for children under 3 years due to its maximum speed.</li><li>2. Choking hazard due to small parts.</li><li>3. For family and domestic use only.</li><li>4. Protective equipment should be worn.</li><li>5. Not to be used in traffic.</li><li>6. Adult assembly required.</li><li>7. Protective equipment should be worn.</li><li>8. Do not allow more than one rider.</li></ol> |

## 1. Directory:

Before use  
 Specification  
 Cautions for Safety  
 Parts Drawing  
 Product Assembly Chart  
 Use of Information  
 Fused Tube  
 Charging  
 Care and Maintenance  
 Trouble Shooting  
 Warning  
 Battery Disposal

## 2. Before use:

Please read the product manual carefully before using the product. It will facilitate you and your child to get the most comfort, performance and enjoyment when riding. Further, the manual will also provide you with the details of installation and correct use. This can help avoid damages and injury caused by improper operation.

The manual also tells you a lot about safety precautions and it is advised that parents go through them and guide their child with patience. Please place the instructions in an easily accessible place for future reference.

## 3. Specification:

|                     |   |               |  |
|---------------------|---|---------------|--|
| External Dimensions | 42.91x26.37x23.81Inch                     | Power Mode    | Rechargeable                               |
| User's proper age   | suitable for children around 3-8years old | Fuse Spec     | Fuse Spec. Self-resetting Fuse             |
| Loading limitation  | 66 lbs.                                   | Charging Time | 4-5 hours. Do not charge more than 4 hours |
| Speed               | 1.5-1.8 mph                               | Power life    | 280 times charging.                        |
| Battery Spec        | 12V, 7Ah                                  | Charging Spec | 12V 800MA                                  |

## Table 1 Remote control instructions

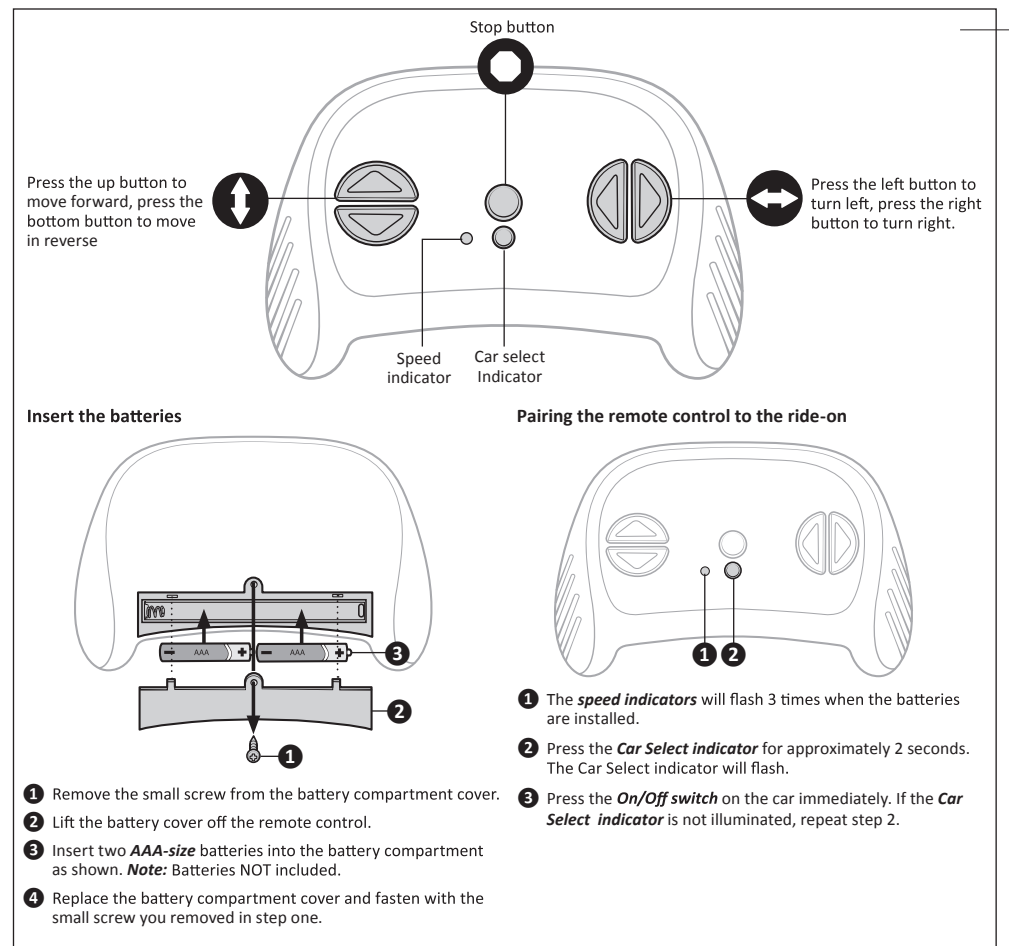

### ⚠ WARNING

- DO NOT mix old and new batteries.
- DO NOT mix alkaline, standard (carbon-zinc), or rechargeable (nickel-cadmium) batteries.
- Non-rechargeable batteries are not to be recharged. Batteries are to be inserted with the correct polarity. Exhausted batteries are to be removed from the toy. The supply terminals are not to be short-circuited. Rechargeable batteries are only to be charged under adult supervision.
- Rechargeable batteries are to be removed from the toy before being charged.

Please keep this manual for future reference as it contains important information

## 4. Cautions For Safety:

- (1). The product must be assembled by adults. Before use check whether the adult assembles correctly according to the instructions.
- (2). To avoid injury to small parts, children under 3 years old prohibited.
- (3). Children should stay away from plastic bags, prevent children from covering the head leading to a choking hazard
- (4). When using, Children should wear safety helmets and must be guarded and guided by adults, and not leave the child alone to avoid accidents.
- (5). The toy car is for one person. The maximum weight limit of the tractor is 66lbs. suitable for over 3 years to 8 years old children.
- (6). The toy car should drive on a flat surface It is prohibited to drive on streets, slopes or any other dangerous places.
- (7). When the toy car is moving, the user should not be free to turn the forward and backward switch. After the toy car stops, the user can use the forward and backward options.
- (8). Do not reverse push and lateral pull the toy car in normal driving to prevent the rollover risk.
- (9). The battery charger to be operated by an adult, do not let children charge the battery.
- (10). Do not directly wash the tractor with water to prevent water damage to the motor circuit.
- (11). Adults should check regularly (once every two weeks suggested), wires, plugs, electrical, housing, steering systems, fastening is normal or not. If there is any problem, then stop the use until it's fully restored.
- (12). The toy car battery and the charger is not separate toy, Don't play with them.
- (13). Please use the matched battery and charger and a stable charging voltage to ensure safety when charging, and extend battery life.
- (14). Spare parts exchange should be operated by an adult because the battery is very heavy, and the internal acidic electrolyte if any leakage should avoid contact with liquid, and if the internal acidic electrolyte leaks, professional disposition would be required.
- (15). Avoid the short circuit of the power to prevent the risk of burning.
- (16). This product cannot store in high-temperature places or near the fire, in order to prevent melting the plastic parts and fires, charging away from flammable materials is important.
- (17). Shall not use the different specifications fuse.
- (18). Don't recharge the non-rechargeable batteries, don't mix the old and new or different types of batteries. Batteries should not be casually discarded, and attention should be paid to environmental protection.
- (19). If you are not using the tractor in the long-term, please pull out the battery on the red line to ensure circuit safety.
- (20). Do not expose the tractor to the sun and avoid using the car in the rainy days.
- (21). Keep the package bag and the instruction manual in the proper place for further use because there is important information on it.

## 5. Parts Drawing

| Number | Part name                | Quantity |
|--------|--------------------------|----------|
| 1      | Body                     | 1        |
| 2      | Seat                     | 1        |
| 3      | Motor                    | 2        |
| 4      | Rear axle                | 1        |
| 5      | Rear wheel               | 2        |
| 6      | Rear wheel insert parts  | 2        |
| 7      | Rear wheel cover         | 2        |
| 8      | 12mm spacer              | 6        |
| 9      | 10mm nut                 | 4        |
| 10     | Wheel Cap                | 4        |
| 11     | Front wheel insert parts | 4        |
| 12     | Front wheel              | 2        |

| Number | Part name                              | Quantity |
|--------|--|----------|
| 13     | Front wheel cover                      | 2        |
| 14     | Steering wheel (Includes bolt and nut) | 1        |
| 15     | Charger                                | 1        |

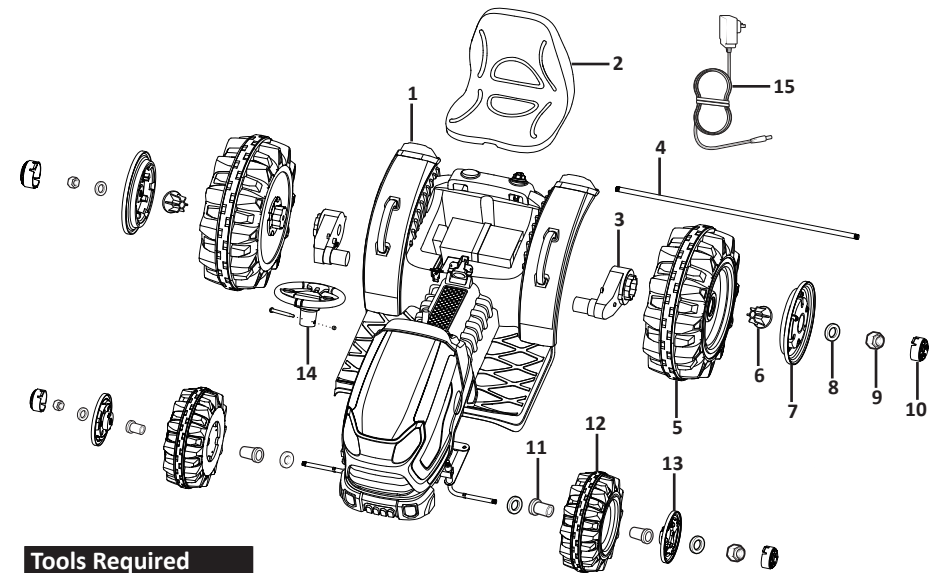

### Tools Required

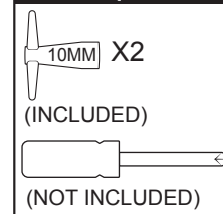

## 6. Product assembly chart:

### 6.1 Procedure for installing the wheel:

1. Insert the rear axle.
2. Insert the motor into the rear axle. Note that the color of the wires on the motor should be consistent with that in the body.
3. Insert the rear wheel into the rear axle.
4. According to the drawing, insert the insert, front hub and gasket into the rear axle in turn, clip in the wheel, screw on the nut, and finally cover the wheel cap.
5. According to the drawing, insert the inserts, gasket, front wheel and front hub into the steering gear in turn, clip in the wheel, screw-on the nut, and finally cover the wheel cap.

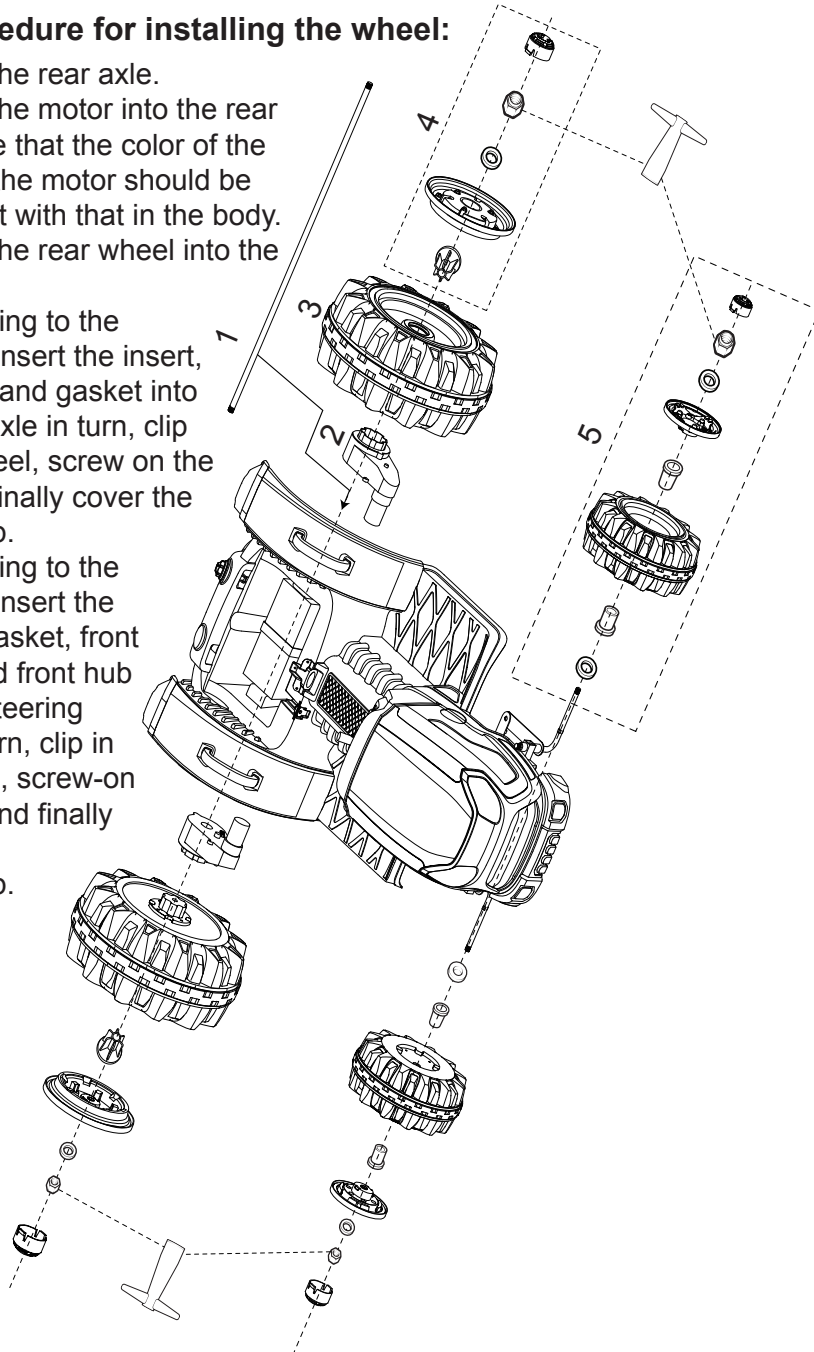

### 6.2 Procedure for installing steering wheel:

1. Connect the wires.
2. Place the steering wheel over the steering column.
3. Align the holes in the steering wheel with the holes in the steering column. Insert the bolt completely through the steering wheel base and fasten with a nut.

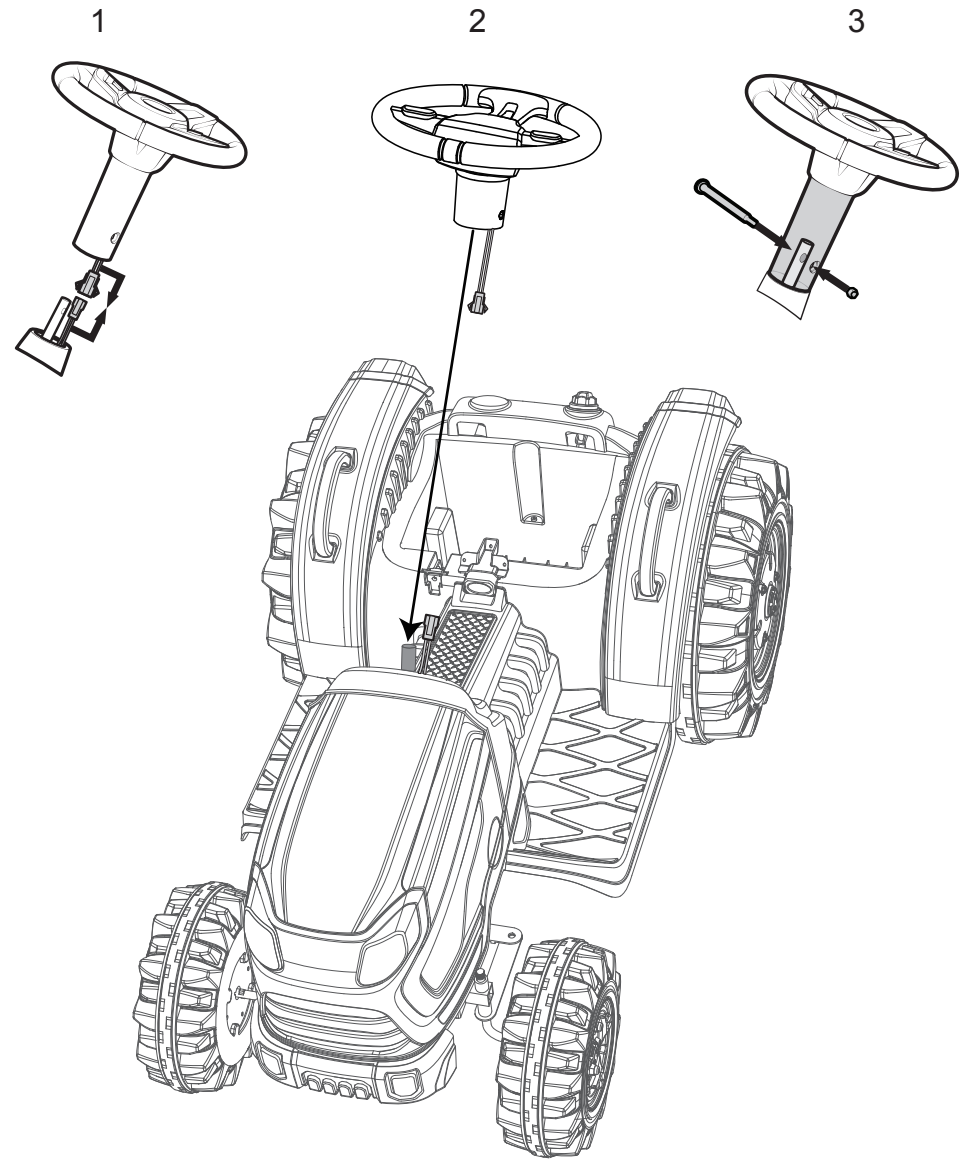

### 6.3 Procedure for installing seat:

1. Wire connecting motor and battery.
2. Clip the seat into the body.
3. As shown in Figure 3, press the button to open the seat.

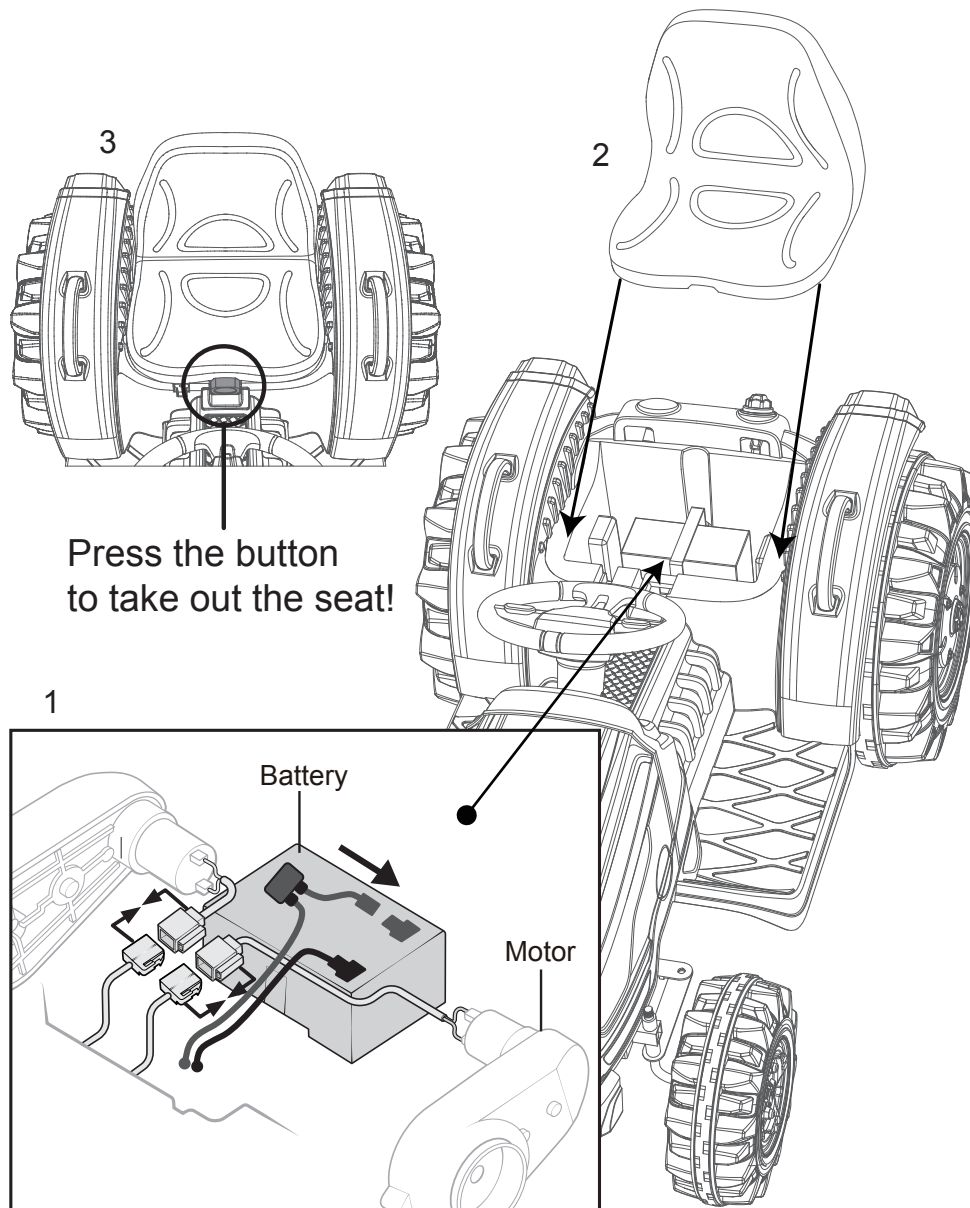

## 7. THE USE OF INFORMATION:

### ⚠ATTENTION!

- (1) Before using it for the first time, same as Picture 1, check the battery under the seat. Connect the battery's power cord. According to the colors of the plugs and the battery, connect the main wire to the battery wire (with RED to RED, BLACK to BLACK) any wrong connection may cause a short circuit or other faults.
- (2) Refer the picture 2; the position with arrow is the charger hole. Charge the battery if the vehicle runs slower than normal. Charge the battery for 8-10 hours. But it cannot be over 15 hours. It is normal that the power charger and the battery become warmer while the battery is on charging.
- (3) Function information, like Picture (3)

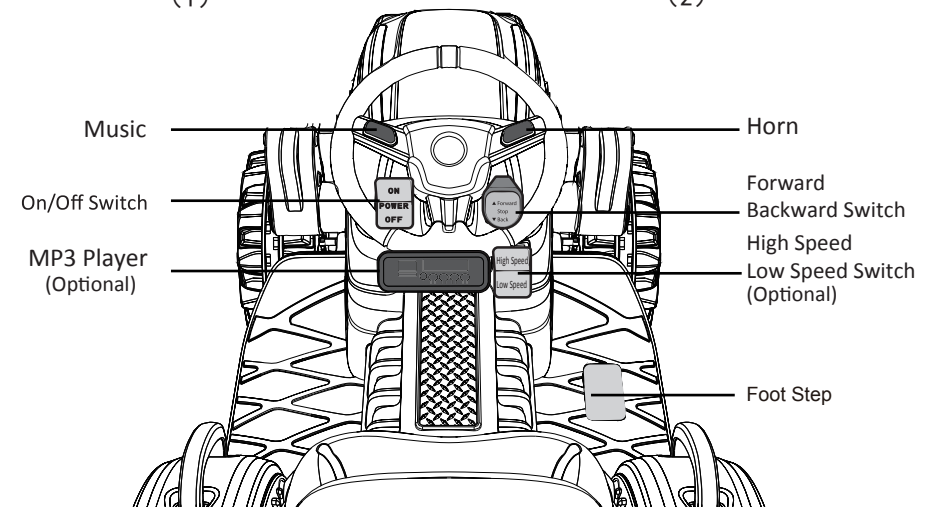
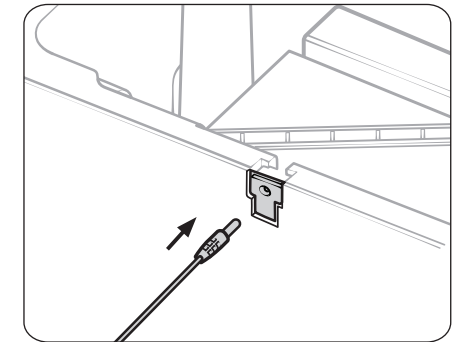
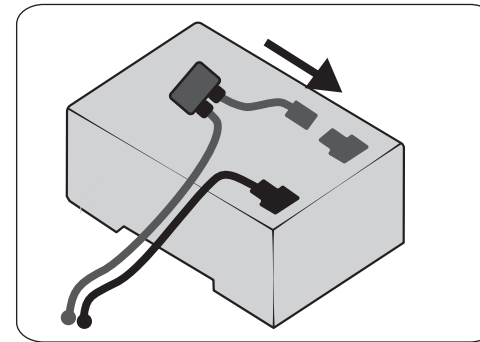

If you have selected the remote control function, please refer to attached table 1.

## 8. Fused tube:

### ⚠ WARNING

When overloading or improper use, the fuse will be cut automatically for 10-20 seconds. And then will be connect the power automatically.

To avoid the fuse cut the power, pls note:

1. The maximum weight of the toy car is limited to 30kg.
2. Not stall the car running or heavy trailer behind.
3. May not liquid immersion, it may cause the short circuit.
4. Do not revise the motorcycle's circuit or the structure.

## 9. CHARGING:

⚠ **WARNING:** For the purposes of recharging the battery, Only use the charger provided with this ride-on.

(1). Like the below picture, insert the charger plug into the charging hole under the vehicle seat.

(2). Like the picture, the power plugs into the matched stable AC power.

Attention when charging:

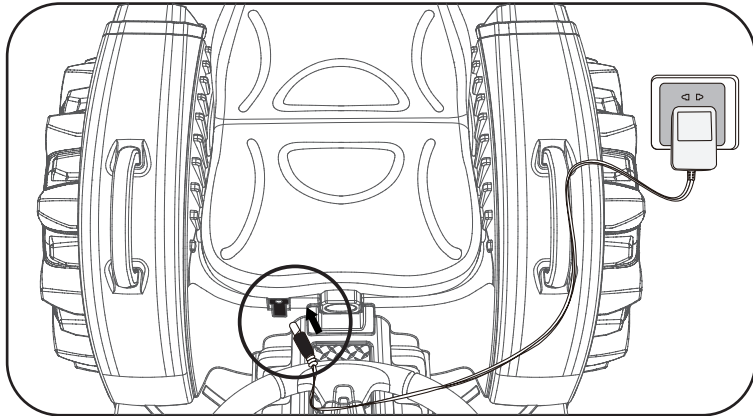

1. Adults should do the battery charging,
2. For the first use when the battery is fully charged, charge for another 4-6 hours.
3. Charge the battery if the vehicle runs slower, can charge up to 8-12 hours. But cannot charge over 15 hours.
4. Cannot open or decompose the battery and charger, should use the matched charger and battery.
5. When charging, do not turn the battery upside down.
6. Before charging, check if the charger, battery and the plug is fine. If it's broken, do not use. If it's repaired, use then
7. Charge the battery fully. If you will store the battery for a long time, then charge it every 3 months, in this way you can extend the lifetime of the battery.

## 10. Care and maintenance:

(1). Adults should regularly check wires, plugs, electrical, housing, steering systems, and speed (once every two weeks). If there is any problem, then stop the use until it's fully restored

(2). To clean vehicles, please use a soft, dry cloth to wipe. You can not use water for cleaning since this will lead to corrosion in the switch and cause switch failure.

(3). This product cannot be stored in high-temperature places or near the fire. The product should be covered on snowy and rainy days.

(4). Charge the battery entirely if you store it for a long time, then charge it every three months. In this way, you can extend the lifetime of the battery.

(5). If you stop using the car, take off the battery, turn off the power switch and disconnect the battery connection

(6). Do not revise the toy car's circuit and structure. The key parts should be maintained and guided by the professional staff.

(7). Don't recharge the non-rechargeable batteries, do not mix the old and new or different types of batteries. Pay attention to the Positive and negative.

(8). Recharge the battery after each use. Only an adult can handle the battery. Recharge the battery at least once a month when the vehicle Raider is not used

## 11. Trouble Shoot:

Vehicle does not move:

1. Check whether the positive and negative wires of the power supply are firmly plugged in.
2. Check whether the power switch is on.
3. The fuse is blown or tripped.
4. Check whether the charger is inserted into the charging hole. If yes, then The toy car will automatically cut off the power supply. After unplugging the charger, it can be used.
5. The foot switch or manual button is stuck below and cannot be pressed?
6. Check whether the wheel is stuck with debris

Slow vehicle movement:

1. Whether the battery is sufficient. If so, it shall be charged in time.
2. Check whether there are debris stuck on the wheel.
3. Whether the vehicle is overloaded.
4. No matter whether the charger is damaged or not, the battery cannot be charged.

The battery cannot be fully charged:

1. Check whether the charger is normal. When the charger is burnt, the charger will heat up This is normal.
2. Check whether the battery is normal.
3. Check whether the charger or battery connection is loose.

## 12. WARNING:

Use caution as misusing or mishandling the battery may cause a FIRE or EXPLOSION which may result in personal injury, property damage, or death. The user must have an appropriate understanding of the potential dangers of NON SPILLABLE LEAD ACID ION BATTERIES before purchase and usage. No express or implied guarantee of compatibility, suitability, or fitness for any particular purpose or device can be made. This battery is manufactured and sold for the intended use of system integrations with proper protection circuitry or battery packs with a BMS (battery management system) or PCB (circuit board/module). This battery is neither designed nor intended to be used with an E-CIGARETTE, VAPORIZER, or similar device and MUST NOT be used with such devices due to RISK OF FIRE or EXPLOSION. If purchasing this battery for resale purposes, you MUST forward ALL warnings to ALL customers for their reference and safety!

- DO NOT USE WITH E-CIGARETTE, VAPORIZER, OR SIMILAR DEVICE
- DO NOT STORE BATTERY LOOSE OR IN A POCKET, PURSE, ETC. ALWAYS USE A PROTECTIVE CASE OR BOX FOR STORAGE AND TRANSPORT
- WHEN NOT IN USE, ALWAYS STORE NON SPILLABLE LEAD ACID ION BATTERIES IN THE PROTECTIVE CASE/BOX.
- Misusing or mishandling Non Spillable lead acid ion batteries can pose a SERIOUS RISK of PERSONAL INJURY, PROPERTY DAMAGE.
- BATTERIES MAY EXPLODE, BURN, OR CAUSE A FIRE IF MISUSED OR MISHANDLED
- Usage of batteries is AT YOUR OWN RISK!
- ONLY use with proper protection circuitry
- DO NOT short circuit intentionally or unintentionally.
- KEEP AWAY from metal/conductive objects to prevent short circuiting.
- DO NOT use if battery is damaged in any way.
- DO NOT over-charge or charge above the maximum voltage rating.
- DO NOT over-discharge or exceed the continuous discharge rating.
- DO NOT modify, disassemble, puncture, cut, crush, or incinerate.
- DO NOT expose to liquids or high temperatures.
- DO NOT solder onto battery, spot weld only.
- DO NOT use force to install or install in reverse/backwards.
- ONLY use within manufacturer's specification
- KEEP AWAY from pets and children.
- ALWAYS charge in or on a fire-proof surface and never leave batteries charging unattended.
- ONLY use a smart charger designed for this specific type of battery.
- DO NOT mix and match brands and models, old and new, used and unused batteries.
- STOP immediately if while charging/storing/using the battery it emits an unusual smell, feels hot, changes color or shape, or appears abnormal in any way.
- It is your responsibility to determine that your charger or device is functioning properly.
- If exposed to battery electrolyte, flush with water immediately and/or immediately contact a physician or emergency services.
- DO NOT throw away in trash; contact your local jurisdiction for proper recycling or disposal.
- Resellers MUST forward ALL warnings to ALL customers for their reference and safety.

## 13. BATTERY DISPOSAL:

### Battery Recycling - Recycling Ride on battery



Ride on toys, electric bikes and electric scooters - we all have them and we all will have to replace our batteries at some point, or perhaps already have.

#### What to do with those used electric kids' car batteries?

You are not allowed to put them out with the trash and can't just toss them in the river or bury them in the back yard because it is devastating to the environment and the public health, not to mention illegal according to Federal law (40 CFR part 273). Most states have their own laws prohibiting the disposal of rechargeable batteries, as well. So, the big question - what to do with the old batteries?

#### The answer: recycle them!

You can take your used rechargeable batteries to one of your local Department of Sanitation's Household Special Waste Drop-off Sites. They offer battery recycling information for Nickel Cadmium (Ni-Cd), Nickel Metal Hydride (Ni-MH), Lithium Ion (Li-ion), or Small Sealed Lead (Pb) weighing 2 pounds or less.

Since most of us use lead batteries weighing much more than 2 pounds, check out your own city's Department of Sanitation web page and see what they have to offer - or else just call them. Another option is retail stores, like auto parts stores or service outlets, which sell new Sealed Lead Acid batteries. Most will likely accept a small number (one or two) of spent Sealed Lead Acid batteries for recycling.

**Tip:** When transporting batteries be sure to eliminate the terminal contacts by either placing the battery in a plastic bag or wrapping black electrical tape around them





Please contact **Best Ride on Cars** before returning this product to the retailer!!!

If you find that you have any trouble with assembly, missing or damaged parts, please contact us at:

Toll-Free: 1-800-671-9786

Ph: 469-209-8741

Or via EMAIL at:

[sales@bestrideoncars.com](mailto:sales@bestrideoncars.com)